

TPS53128 Dual Synchronous Step-Down Controller With Auto-Skip Eco-mode™ For Low Voltage Power Rails

1 Features

- D-CAP2™ Mode Control
 - Fast Transient Response
 - No External Parts Required for Loop Compensation
 - Compatible With Ceramic Output Capacitors
- High Initial Reference Accuracy ($\pm 1\%$)
- Low Output Ripple
- Wide Input Voltage Range: 4.5 V to 24 V
- Output Voltage Range: 0.76 V to 5.5 V
- Low-Side $R_{DS(ON)}$ Loss-Less Current Sensing
- Adaptive Gate Drivers with Integrated Boost Diode
- Adjustable Soft Start
- Non-Sinking Pre-Biased Soft Start
- 350-kHz Switching Frequency
- Cycle-by-Cycle Over-Current Limiting Control
- 30-mV to 300-mV OCP Threshold Voltage
- Thermally Compensated OCP by 4000 ppm/°C at I_{TRIP}
- Auto-Skip Eco-mode™ for High Efficiency at Light Load

2 Applications

- Point-of-Load Regulation in Low Power Systems for Wide Range of Applications
 - Digital TV Power Supply
 - Networking Home Terminal
 - Digital Set-Top Box (STB)
 - DVD Player/Recorder
 - Gaming Consoles

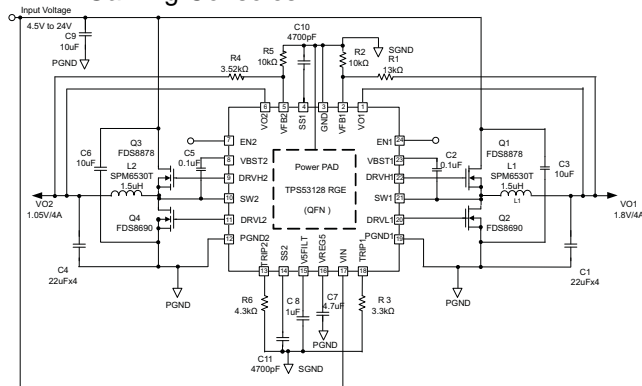

3 Description

The TPS53128 is a dual, adaptive on-time D-CAP2™ mode synchronous buck controller. The part enables system designers to cost effectively complete the suite of various end equipment's power bus regulators with a low external component count and low standby consumption. The main control loop for the TPS53128 uses the D-CAP2™ Mode topology which provides a very fast transient response with no external component.

The TPS53128 also has a proprietary circuit that enables the device to adapt not only low equivalent series resistance (ESR) output capacitors such as POSCAP/SP-CAP, but also ceramic capacitor. The fixed frequency emulated adaptive on-time control supports seamless operation between PWM mode at heavy load condition and reduced frequency operation at light load for high efficiency down to milliampere range. The part provides a convenient and efficient operation with conversion voltages from 4.5 V to 24 V and output voltage from 0.76 V to 5.5 V.

The TPS53128 is available in 4-mm x 4-mm 24 pin QFN (RGE) or 24 pin TSSOP (PW) packages, and is specified from -40°C to 85°C ambient temperature range.

Table 1. Device Information⁽¹⁾

DEVICE NAME	PACKAGE	BODY SIZE
TPS53128	VQFN (24)	4.4 mm x 7.8 mm
	TSSOP (24)	4 mm x 4 mm

(1) For all available packages, see the orderable addendum at the end of the datasheet.

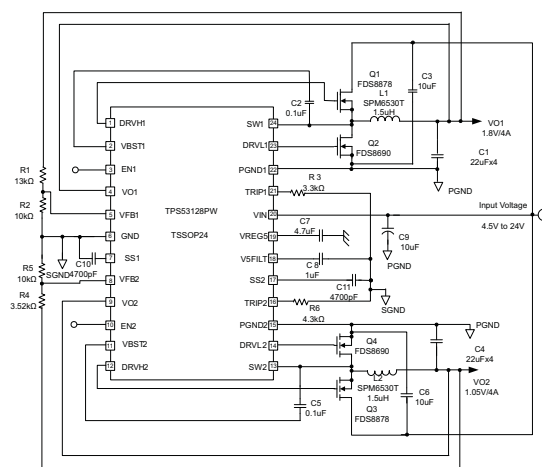

Table of Contents

1 Features	1	7.3 Feature Description	11
2 Applications	1	7.4 Device Functional Modes	14
3 Description	1	8 Application and Implementation	15
4 Revision History	2	8.1 Application Information	15
5 Pin Configuration and Functions	3	8.2 Typical Application	15
6 Specifications	4	9 Power Supply Recommendations	23
6.1 Absolute Maximum Ratings	4	10 Layout	24
6.2 Handling Ratings	4	10.1 Layout Guidelines	24
6.3 Recommended Operating Conditions	4	10.2 Layout Example	24
6.4 Thermal Information	5	11 Device and Documentation Support	25
6.5 Electrical Characteristics	5	11.1 Trademarks	25
6.6 Typical Characteristics	7	11.2 Electrostatic Discharge Caution	25
7 Detailed Description	10	11.3 Glossary	25
7.1 Overview	10	12 Mechanical, Packaging, and Orderable Information	25
7.2 Functional Block Diagram	10		

4 Revision History

NOTE: Page numbers for previous revisions may differ from page numbers in the current version.

Changes from Original (July 2010) to Revision A	Page
• Changed format to meet latest data sheet standards; added new sections and moved existing sections	1
• Added Eco-mode bullet to Features	1
• Added QFN and TSSOP schematics	1
• Added $V_{(ESD)}$ value	4
• Added thermal information	5
• Changed min for V_{VREG5}	5
• Changed max for R_{DRVL} at -100 mA	5
• Changed the I(SSC) Min value From: -1.5 to -2.5 μ A and the Max value From: -2.5 To: -1.5 μ A	6
• Added Overview section.	10
• Added Device Functional Modes	14
• Added Design Parameter values	16
• Added Power Supply Recommendations	23
• Added Layout Example image	24

5 Pin Configuration and Functions

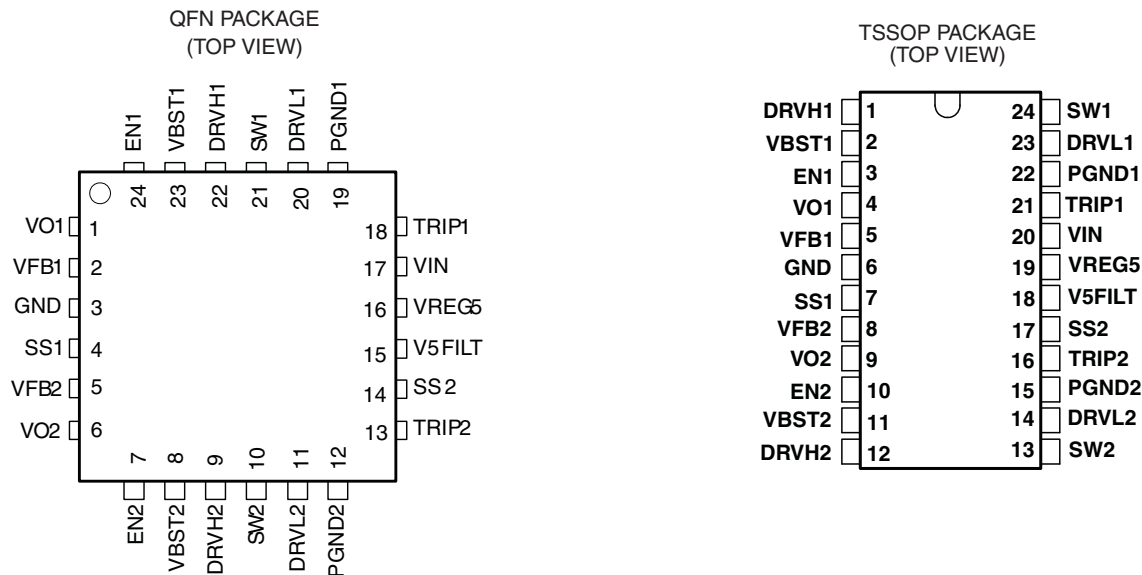
Table 2. Pin Functions

PIN			I/O	DESCRIPTION
NAME	RGE	PW		
VBST1, VBST2	23, 8	2, 11	I	Supply input for high-side NFET driver. Bypass to SWx with a high-quality 0.1- μ F ceramic capacitor. An external schottky diode can be added from VREG5 if forward drop is critical to drive the high-side FET.
EN1, EN2	24, 7	3, 10	I	Enable. Pull High to enable SMPS.
VO1, VO2	1, 6	4, 9	I	Output voltage inputs for on-time adjustment and output discharge. Connect directly to the output voltage.
VFB1, VFB2	2, 5	5, 8	I	D-CAP2 feedback inputs. Connect to output voltage with resistor divider.
GND	3	6	I	Signal ground pin. Connect to PGND1, PGND2 and system ground at a single point.
DRVH1, DRVH2	22, 9	1, 12	O	High-side N-Channel MOSFET gate driver outputs. SWx referenced drivers switch between SWx (OFF) and VBSTx (ON).
SW1, SW2	21, 10	24, 13	I/O	Switch node connections for both the high-side drivers and the over current comparators.
DRVL1, DRVL2	20, 11	23, 14	O	Low-side N-Channel MOSFET gate driver outputs. PGND referenced drivers switch between PGNDx (OFF) and VREG5 (ON).
PGND1, PGND2	19, 12	22, 15	I/O	Power ground connections for both the low-side drivers and the over current comparators. Connect PGND1, PGND2 and GND strongly together near the IC.
TRIP1, TRIP2	18, 13	21, 16	I	Over current threshold programming pin. Connect to GND with a resistor to GND to set threshold for low-side $R_{DS(ON)}$ current limit.
VIN	17	20	I	Supply Input for 5-V linear regulator. Bypass to GND with a minimum high-quality 0.1- μ F ceramic capacitor.
V5FILT	15	18	I	5-V supply input for the entire control circuitry except the MOSFET drivers. Bypass to GND with a minimum high-quality 1.0- μ F ceramic capacitor. V5FILT is connected to VREG5 via an internal 10- Ω resistor.
VREG5	16	19	O	Output of 5-V linear regulator and supply for MOSFET drivers. Bypass to GND with a minimum high-quality 4.7- μ F ceramic capacitor. VREG5 is connected to V5FILT via an internal 10- Ω resistor.
SS1, SS2	4, 14	7, 17	O	Soft-start programming pin. Connect capacitor from SSx pin to GND to program soft-start time.

6 Specifications

6.1 Absolute Maximum Ratings

 over operating free-air temperature range (unless otherwise noted) ⁽¹⁾

		VALUE	UNIT
V _I	Input voltage	VIN, EN1, EN2	–0.3 to 26
		VBST1, VBST2	–0.3 to 32
		VBST1 - SW1, VBST2 - SW2	–0.3 to 6
		V5FILT, VFB1, VFB2, TRIP1, TRIP2, VO1, VO2	–0.3 to 6
		SW1, SW2	–2 to 26
V _O	Output voltage	DRVH1, DRVH2	–1 to 32
		DRVH1 - SW1, DRVH2 - SW2	–0.3 to 6
		DRVL1, DRVL2, VREG5, SS1, SS2	–0.3 to 6
		PGND1, PGND2	–0.3 to 0.3
T _A	Operating ambient temperature	–40 to 85	°C
T _J	Junction temperature	–40 to 150	°C

(1) Stresses beyond those listed under "absolute maximum ratings" may cause permanent damage to the device. These are stress ratings only and functional operation of the device at these or any other conditions beyond those indicated under "recommended operating conditions" are not implied. Exposure to absolute-maximum-rated conditions for extended periods may affect device reliability.

6.2 Handling Ratings

		MIN	MAX	UNIT	
T _{stg}	Storage temperature range	–55	150	°C	
V _(ESD)	Electrostatic discharge	Human body model (HBM), per AN/ESDA/JEDEC JS-001, all pins ⁽¹⁾	–2000	2000	V
		Charged device model (CDM), per JEDEC specification JESD22-C101, all pins ⁽²⁾	–500	500	V

(1) JEDEC document JEP155 states that 500-V HBM allows safe manufacturing with a standard ESD control process.

(2) JEDEC document JEP157 states that 250-V CDM allows safe manufacturing with a standard ESD control process.

6.3 Recommended Operating Conditions

over operating free-air temperature range (unless otherwise noted)

		MIN	MAX	UNIT
V _{IN}	Supply input voltage	VIN	4.5	24
		V5FILT	4.5	5.5
V _I	Input voltage	VBST1, VBST2	–0.1	30
		VBST1 - SW1, VBST2 - SW2	–0.1	5.5
		VFB1, VFB2, VO1, VO2	–0.1	5.5
		TRIP1, TRIP2	–0.1	0.3
		EN1, EN2	–0.1	24
		SW1, SW2	–1.8	24
V _O	Output voltage	DRVH1, DRVH2	–0.1	30
		VBST1 - SW1, VBST2 - SW2	–0.1	5.5
		DRVL1, DRVL2, VREG5, SS1, SS2	–0.1	5.5
		PGND1, PGND2	–0.1	0.1
T _A	Operating free-air temperature	–40	85	°C
T _J	Operating junction temperature	–40	125	°C

6.4 Thermal Information

THERMAL METRIC ⁽¹⁾		TPS53128		UNIT
		RGE	PW	
		24 PIN	24PIN	
R _{θJA}	Junction-to-ambient thermal resistance	35.4	88.9	°C/W
R _{θJC(top)}	Junction-to-case (top) thermal resistance	39.1	26.5	
R _{θJB}	Junction-to-board thermal resistance	13.6	43.5	
ψ _{JT}	Junction-to-top characterization parameter	0.5	1.1	
ψ _{JB}	Junction-to-board characterization parameter	13.6	43	
R _{θJC(bot)}	Junction-to-case (bottom) thermal resistance	3.8	N/A	

(1) For more information about traditional and new thermal metrics, see the *IC Package Thermal Metrics* application report, [SPRA953](#).

6.5 Electrical Characteristics

over operating free-air temperature range (unless otherwise noted)

PARAMETER		TEST CONDITIONS	MIN	TYP	MAX	UNIT
SUPPLY CURRENT						
I _{IN}	VIN supply current	VIN current, T _A = 25°C, VREG5 tied to V5FILT, EN1 = EN2 = 5 V, VFB1 = VFB2 = 0.8 V, SW1 = SW2 = 0.5 V		450	800	μA
I _{VINSDN}	VIN shutdown current	VIN current, T _A = 25°C, no load, EN1 = EN2 = 0 V, VREG5 = ON		30	60	μA
VFB VOLTAGE AND DISCHARGE RESISTANCE						
V _{BG}	Bandgap initial regulation accuracy	T _A = 25°C	-1		1	%
V _{VFBTHx}	VFBx threshold voltage	T _A = 25°C, SW _{inj} = OFF	755	765	775	mV
		T _A = 0°C to 70°C, SW _{inj} = OFF ⁽¹⁾	753.5		776.5	
		T _A = -40°C to 85°C, SW _{inj} = OFF ⁽¹⁾	752		778	
I _{VFB}	VFB input current	VFBx = 0.8 V, T _A = 25°C	-100	-10	100	nA
R _{Dischg}	VO discharge resistance	ENx = 0 V, VOx = 0.5 V, T _A = 25°C		40	80	Ω
VREG5 OUTPUT						
V _{VREG5}	VREG5 output voltage	T _A = 25°C, 5.5 V < VIN < 24 V, 0 < I _{VREG5} < 10 mA	4.6	5.0	5.2	V
V _{LN5}	Line regulation	5.5 V < VIN < 24 V, I _{VREG5} = 10 mA			20	mV
V _{LD5}	Load regulation	1 mA < I _{VREG5} < 10 mA			40	mV
I _{VREG5}	Output current	VIN = 5.5 V, V _{VREG5} = 4.0 V, T _A = 25°C		170		mA
OUTPUT: N-CHANNEL MOSFET GATE DRIVERS						
R _{DRVH}	DRVH resistance	Source, I _{DRVHx} = -100 mA		5.5	11	Ω
		Sink, I _{DRVHx} = 100 mA		2.5	5	
R _{DRVL}	DRVL resistance	Source, I _{DRVLx} = -100 mA		4	12	Ω
		Sink, I _{DRVLx} = 100 mA		2	4	
T _D	Dead time	DRVHx-low to DRVLx-on	20	50	80	ns
		DRVLx-low to DRVHx-on	20	40	80	
INTERNAL BOOST DIODE						
V _{FBST}	Forward voltage	V _{VREG5-VBSTx} , I _F = 10 mA, T _A = 25°C	0.7	0.8	0.9	V
I _{VBSTLK}	VBST leakage current	VBSTx = 29 V, SWx = 24 V, T _A = 25°C		0.1	1	μA

(1) Not production tested - ensured by design.

Electrical Characteristics (continued)

over operating free-air temperature range (unless otherwise noted)

PARAMETER		TEST CONDITIONS	MIN	TYP	MAX	UNIT
ON-TIME TIMER CONTROL						
T _{ON1L}	CH1 on time	SW1 = 12 V, VO1 = 1.8 V		490		ns
T _{ON2L}	CH2 on time	SW2 = 12 V, VO2 = 1.8 V		390		ns
T _{OFF1L}	CH1 min off time	SW1 = 0.7 V, T _A = 25°C, VFB1 = 0.7 V		285		ns
T _{OFF2L}	CH2 min off time	SW2 = 0.7 V, T _A = 25°C, VFB2 = 0.7 V		285		ns
SOFT START						
I _{SSC}	SS1/SS2 charge current	V _{SS1} /V _{SS2} = 0 V, T _A = 25°C	-2.5	-2	-1.5	μA
T _C I _{SSC}	I _{SSC} temperature coefficient	On the basis of 25°C ⁽¹⁾	-4		3	nA/°C
I _{SSD}	SS1/SS2 discharge current	V _{SS1} /V _{SS2} = 0.5 V	100	150		μA
UVLO						
V _{UV5VFILT}	V5FILT UVLO threshold	Wake up	3.7	4.0	4.3	V
		Hysteresis	0.2	0.3	0.4	
LOGIC THRESHOLD						
V _{ENH}	ENx high-level input voltage	EN 1/2	2.0			V
V _{ENL}	ENx low-level input voltage	EN 1/2			0.3	V
CURRENT SENSE						
I _{TRIP}	TRIP source current	V _{TRIPx} = 0.1 V, T _A = 25°C	8.5	10	11.5	μA
T _C I _{TRIP}	I _{TRIP} temperature coefficient	On the basis of 25°C		4000		ppm/°C
V _{OCLoff}	OCP compensation offset	(V _{TRIPx-GND} -V _{PGNDx-SWx}) voltage, V _{TRIPx-GND} = 60 mV, T _A = 25°C	-15	0	15	mV
		(V _{TRIPx-GND} -V _{PGNDx-SWx}) voltage, V _{TRIPx-GND} = 60 mV	-20		20	
V _{Rtrip}	Current limit threshold setting range	V _{TRIPx-GND} voltage	30		300	mV
OUTPUT UNDERVOLTAGE AND OVERVOLTAGE PROTECTION						
V _{OVP}	Output OVP trip threshold	OVP detect	110	115	120	%
T _{OVPDEL}	Output OVP prop delay			1.5		μs
V _{UVP}	Output UVP trip threshold	UVP detect	65	70	75	%
		Hysteresis (recover < 20 μs)		10		
T _{UVPDEL}	Output UVP delay		17	30	40	μs
T _{UVPEN}	Output UVP enable delay	UVP enable delay / soft-start time	x1.4	x1.7	x2.0	ms
THERMAL SHUTDOWN						
T _{SDN}	Thermal shutdown threshold	Shutdown temperature ⁽¹⁾		150		°C
		Hysteresis ⁽¹⁾		20		

6.6 Typical Characteristics

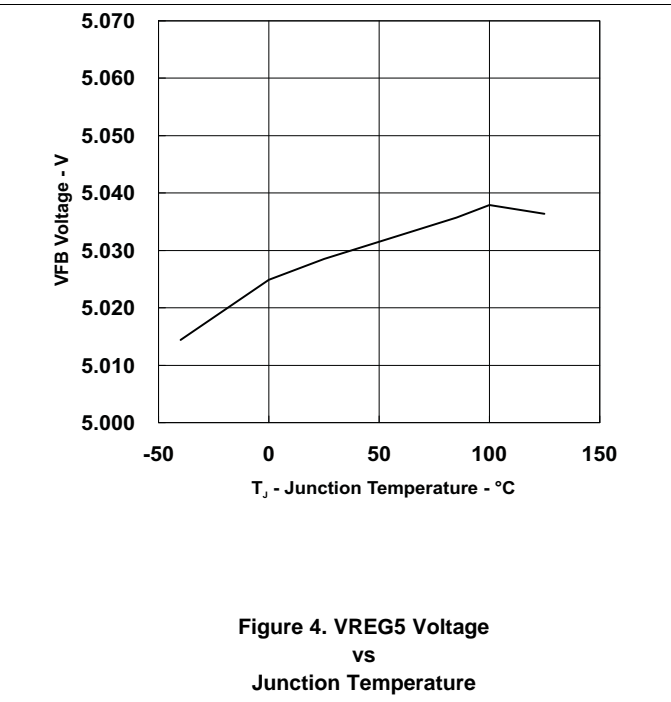
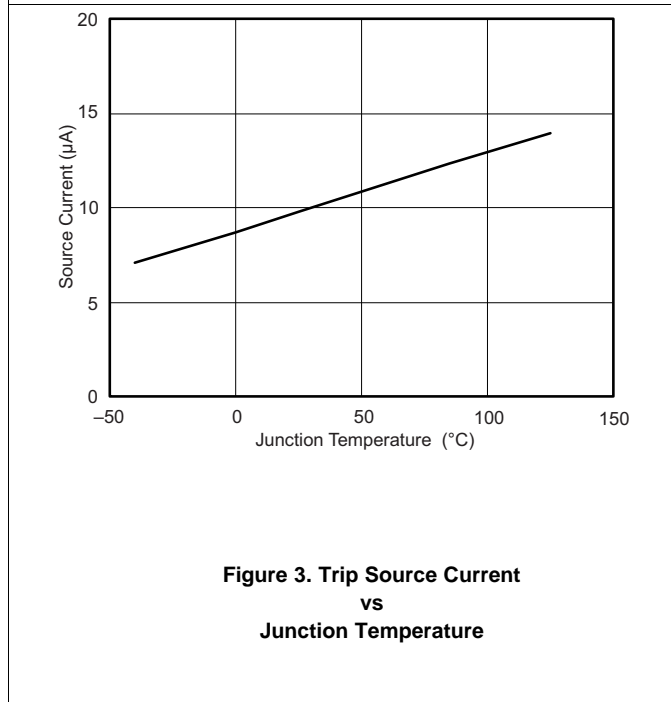
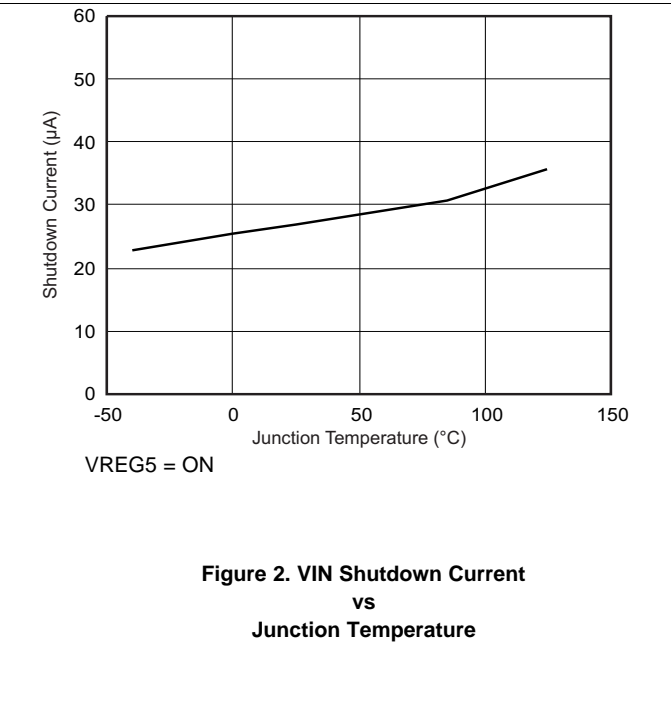
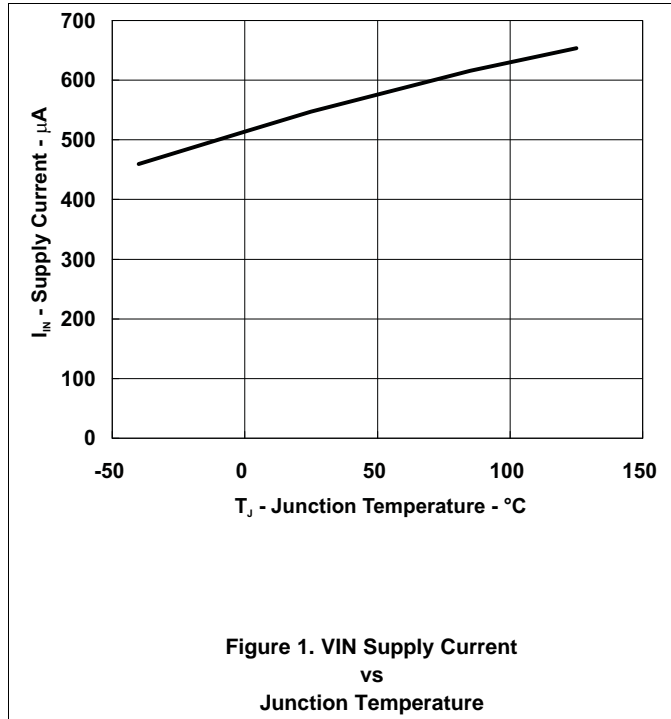

Typical Characteristics (continued)

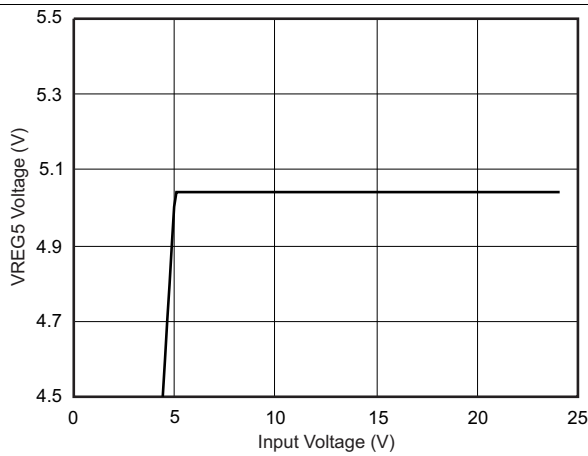

Figure 5. VREG5 Voltage vs Input Voltage

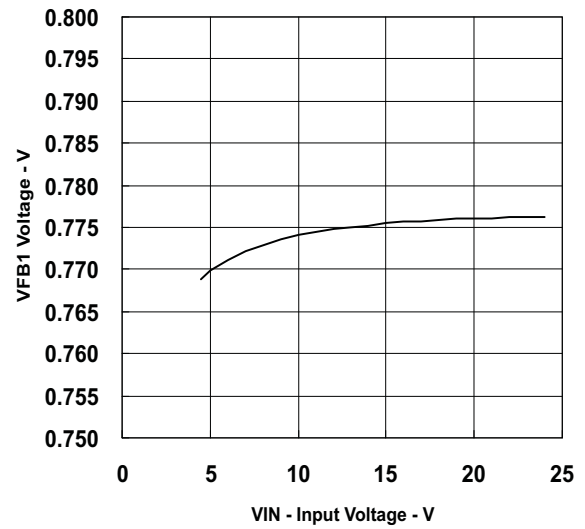

Figure 6. VFB1 Voltage vs Input Voltage

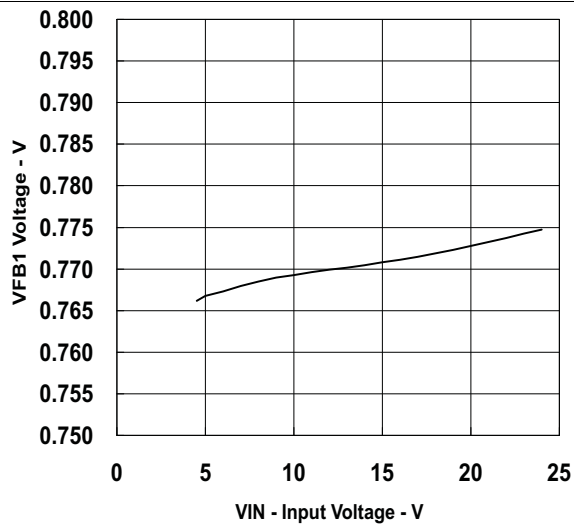

Figure 7. VFB2 Voltage vs Input Voltage

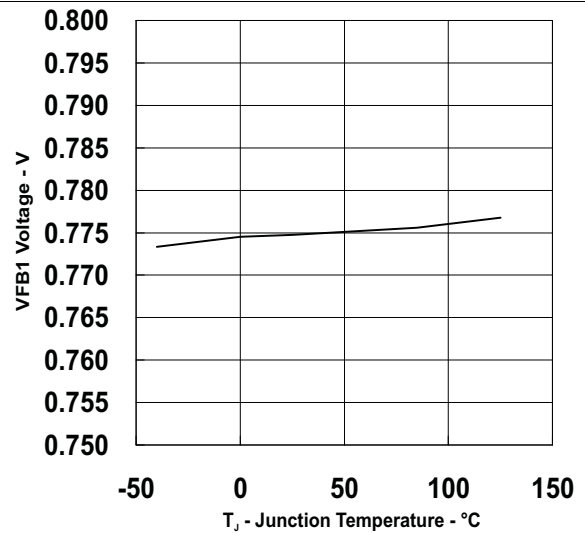
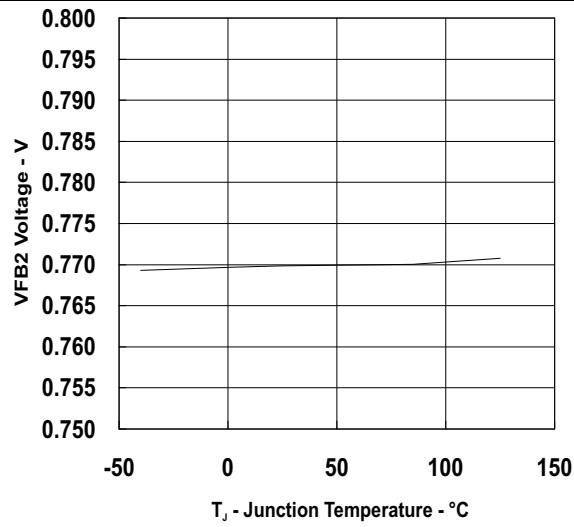

Figure 8. VFB1 Voltage vs Junction Temperature

Typical Characteristics (continued)



**Figure 9. VFB2 Voltage
vs
Junction Temperature**

7 Detailed Description

7.1 Overview

The TPS53128 is a dual, adaptive on-time D-CAP2™ mode synchronous buck controller. The part enables system designers to cost-effectively complete the suite of various end equipment power bus regulators with a low external component count and low standby consumption. The main control loop for the TPS53128 uses the D-CAP2™ Mode topology, which provides a fast transient response with no external component.

The TPS53128 also has a proprietary circuit that enables the device to adapt not only low equivalent series resistance (ESR) output capacitors such as POSCAP/SP-CAP, but also to ceramic capacitors. The fixed frequency, emulated adaptive on-time control supports seamless operation between PWM mode at heavy load condition and reduced frequency operation at light load for high efficiency, down to the milliampere range. The part provides a convenient and efficient operation, with conversion voltages from 4.5 to 24 V and output voltage from 0.76 to 5.5 V.

7.2 Functional Block Diagram

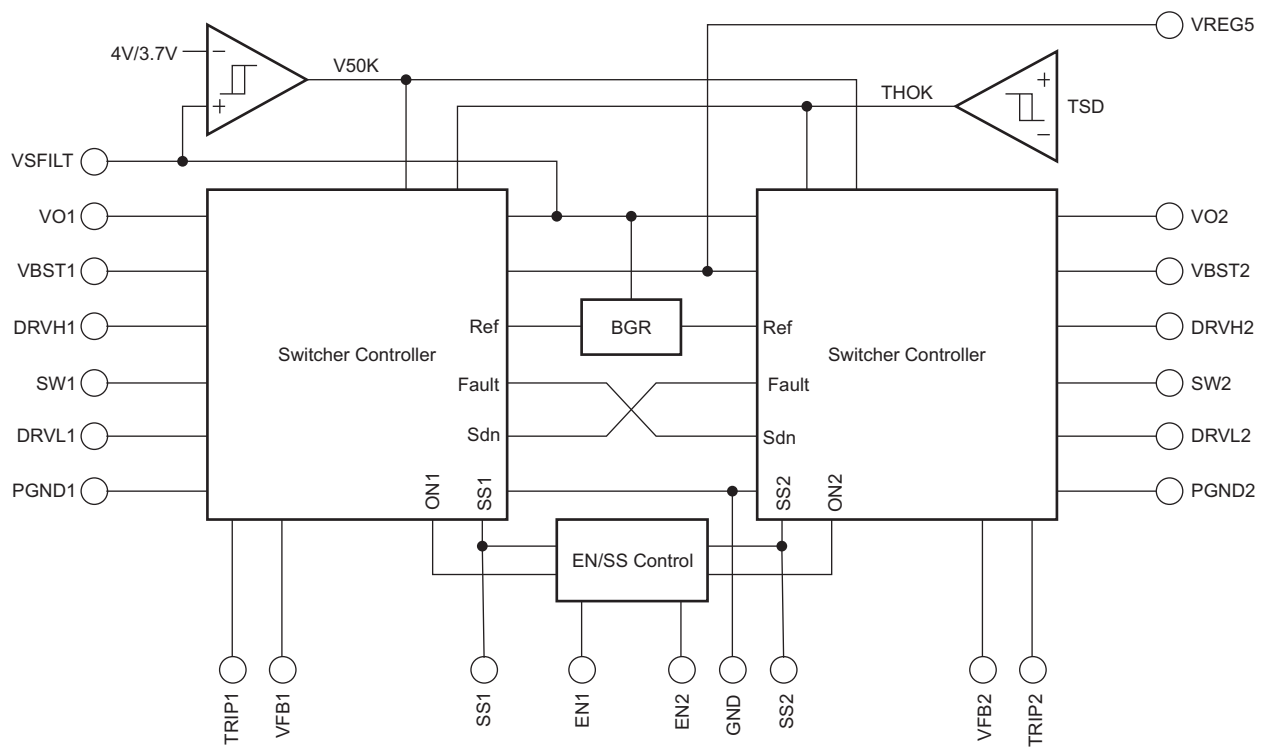

Functional Block Diagram (continued)

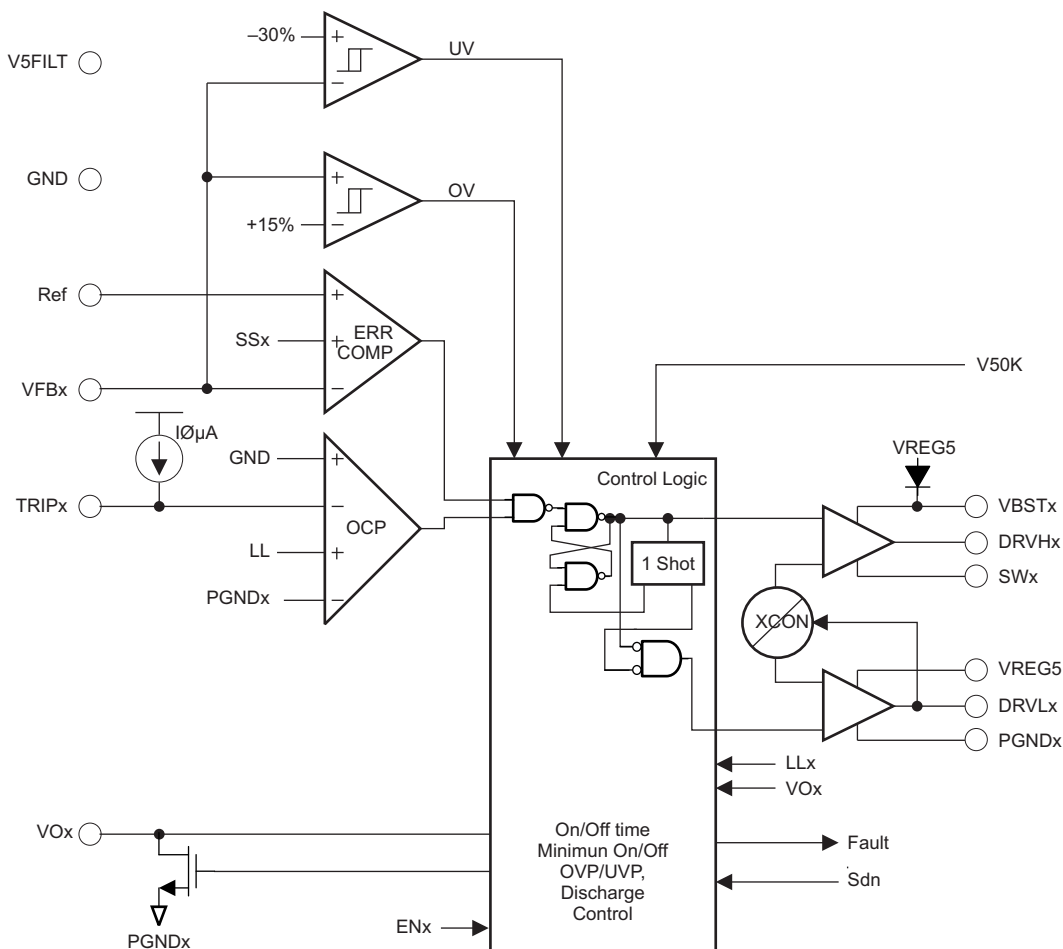

7.3 Feature Description

7.3.1 PWM Operation

The main control loop of the TPS53128 is an adaptive on-time pulse width modulation (PWM) controller using a proprietary D-CAP2™ mode control. D-CAP2™ mode control combines constant on-time control with an internal compensation circuit for pseudo-fixed frequency and low external component count configuration with both low ESR and ceramic output capacitors. It is stable even with virtually no ripple at the output.

At the beginning of each cycle, the synchronous high-side MOSFET is turned on. After an internal one-shot timer expires, this MOSFET is turned off. When the feedback voltage falls below the reference voltage, the one-shot timer is reset and the high-side MOSFET is turned back on. The one shot is set by the converter input voltage VIN, and the output voltage VO, to maintain a pseudo-fixed frequency over the input voltage range. An internal ramp is added to the reference voltage to simulate output ripple, eliminating the need for ESR induced output ripple from D-CAP mode control.

7.3.2 Light-Load Condition

TPS53128 automatically reduces switching frequency at light-load conditions to maintain high efficiency. This reduction of frequency is achieved smoothly and without increase of VOUT ripple or load regulation. Detail operation is described as follows. As the output current decreases from heavy-load condition, the inductor current is also reduced, and eventually comes to the point that its valley touches zero current, which is the boundary between continuous conduction and discontinuous condition modes. The low-side MOSFET is turned off when this zero inductor current is detected. As the load current is further decreased, the converter runs in

Feature Description (continued)

discontinuous conduction mode and it takes longer and longer to discharge the output capacitor to the level that requires the next ON cycle. The ON time is kept the same as that in the heavy-load condition. In reverse, when the output current increases from light load to heavy load, the switching frequency increases to the preset value as the inductor current reaches the continuous conduction. The transition load point to the light load operation, $I_{OUT(LL)}$ (i.e., threshold between continuous and discontinuous condition mode) can be calculated as follows.

$$I_{OUT(LL)} = \frac{1}{2 \times L \times f_{SW}} \frac{V_{IN} - V_{OX}}{V_{IN}} \times V_{OX} \quad (1)$$

Where f_{SW} is the PWM switching frequency.

Switching frequency versus output current in the light-load condition is a function of L , f_{SW} , V_{IN} and V_{OUT} , but it decreases almost proportional to the output current from the $I_{OUT(LL)}$ given in [Equation 1](#).

7.3.3 Drivers

Each channel of the TPS53128 contains two high-current resistive MOSFET gate drivers. The low-side driver is a PGND referenced, VREG5 powered driver designed to drive the gate of a high-current, low $R_{DS(ON)}$ N-channel MOSFET whose source is connected to PGND. The high-side driver is a floating SWx referenced VBST powered driver designed to drive the gate of a high-current, low $R_{DS(ON)}$ N-channel MOSFET. To maintain the VBST voltage during the high-side driver ON time, a capacitor is placed from SWx to VBSTx. Each driver draws average current equal to gate charge (Q_g at $V_{gs} = 5$ V) times switching frequency (f_{SW}).

To prevent cross-conduction, there is a narrow dead-time when both high-side and low-side drivers are OFF between each driver transition. During this time the inductor current is carried by one of the MOSFETs body diodes.

7.3.4 PWM Frequency And Adaptive On-Time Control

TPS53128 employs adaptive on-time control scheme and does not have a dedicated on board oscillator.

TPS53128 runs with pseudo-constant frequency by using the input voltage and output voltage to set the on-time one-shot timer. The on-time is inversely proportional to the input voltage and proportional to the output voltage. Therefore, when the duty ratio is V_{OUT}/V_{IN} , the frequency is constant.

7.3.5 5-Volt Regulator

The TPS53128 has an internal 5-V low-dropout (LDO) regulator to provide a regulated voltage for all both drivers and the IC's internal logic. A high-quality 4.7- μ F or greater ceramic capacitor from VREG5 to GND is required to stabilize the internal regulator. An internal 10- Ω resistor from VREG5 filters the regulator output to the IC's analog and logic input voltage, V5FILT. An additional high-quality 1.0- μ F ceramic capacitor is required from V5FILT to GND to filter switching noise from VREG5.

7.3.6 Soft Start

The TPS53128 has a programmable soft-start. When the ENx pin becomes high, 2.0- μ A current begins charging the capacitor connected from the SS pin to GND. The internal reference for the D-CAP2™ mode control comparator is overridden by the soft-start voltage until the soft-start voltage is greater than the internal reference for smooth control of the output voltage during start up.

7.3.7 Pre-Bias Support

The TPS53128 supports pre-bias start-up without sinking current from the output capacitor. When enabled, the low-side driver is held off until the soft-start commands a voltage higher than the pre-bias level (internal soft-start becomes greater than feedback voltage (VFB)), then the TPS53128 slowly activates synchronous rectification by limiting the first DRV1 pulses with a narrow on-time. This limited on-time is then incremented on a cycle-by-cycle basis until it coincides with the full 1-D off-time. This scheme prevents the initial sinking of current from the pre-bias output, and ensure that the output voltage (VOUT) starts and ramps up smoothly into regulation and the control loop is given time to transition from pre-biased start-up to normal mode operation.

Feature Description (continued)

7.3.8 Output Discharge Control

TPS53128 discharges the outputs when ENx is low, or the controller is turned off by the protection functions (OVP, UVP, UVLO, and thermal shutdown). The device discharges output using an internal 40-Ω MOSFET which is connected to VOx and PGNDx. The external low-side MOSFET is not turned on during the output discharge operation to avoid the possibility of causing negative voltage at the output. This discharge ensures that on start the regulated voltage always initializes from 0 V.

7.3.9 Over Current Limit

TPS53128 has cycle-by-cycle over current limit feature. The over current limits the inductor valley current by monitoring the voltage drop across the low-side MOSFET $R_{DS(ON)}$ during the low-side driver on-time. If the inductor current is larger than the over current limit (OCL), the TPS53128 delays the start of the next switching cycle until the sensed inductor current falls below the OCL current. MOSFET $R_{DS(ON)}$ current sensing is used to provide an accuracy and cost effective solution without external devices. To program the OCL, the TRIP pin should be connected to GND through a trip voltage setting resistor, according to the following equations.

$$V_{TRIP} = \left(I_{OCL} - \frac{(V_{IN} - V_O)}{2 \cdot L1 \cdot f_{SW}} \cdot \frac{V_O}{V_{IN}} \right) \cdot R_{DS(ON)} \quad (2)$$

$$R_{TRIP} (k\Omega) = \frac{V_{TRIP} (mV)}{I_{TRIP} (\mu A)} \quad (3)$$

The trip voltage should be between 30 mV to 300 mV over all operational temperature, including the 4000-ppm/°C temperature slope compensation for the temperature dependency of the $R_{DS(ON)}$.

If the load current exceeds the over current limit, the voltage will begin to drop. If the over current conditions continues the output voltage will fall below the under voltage protection threshold and the TPS53128 will shut down.

In an over current condition, the current to the load exceeds the current to the output capacitor; thus the output voltage tends to fall off. Eventually, it will end up with crossing the under voltage protection threshold and shutdown.

7.3.10 Over/Under Voltage Protection

TPS53128 monitors a resistor divided feedback voltage to detect over and under voltage. If the feedback voltage is higher than 115% of the reference voltage, the OVP comparator output goes high and the circuit latches the high-side MOSFET driver OFF and the low-side MOSFET driver ON.

When the feedback voltage is lower than 70% of the reference voltage, the UVP comparator output goes high and an internal UVP delay counter begins counting. After 30 μs, TPS53128 latches OFF both top and bottom MOSFET drivers. This function is enabled approximately $1.7 \times T_{SS}$ after power-on. The OVP and UVP latch off is reset when EN goes low level.

7.3.11 UVLO Protection

TPS53128 has V5FILT under voltage lock out protection (UVLO) that monitors the voltage of V5FILT pin.

When the V5FILT voltage is lower than UVLO threshold voltage, the device is shut off. All output drivers are OFF and output discharge is ON. The UVLO is non-latch protection.

7.3.12 Thermal Shutdown

The TPS53128 includes an over temperature protection shut-down feature. If the TPS53128 die temperature exceeds the OTP threshold (typically 150°C), both the high-side and low-side drivers are shut off, the output voltage discharge function is enabled and then the device is shut off until the die temperature drops. Thermal shutdown is a non-latch protection.

7.4 Device Functional Modes

The TPS53128 has two operating modes. The TPS53128 is in shut down mode when the EN1 and EN2 pins are low. When the EN1 and EN2 pins are pulled high, the TPS53128 enters the normal operating mode.

8 Application and Implementation

8.1 Application Information

8.2 Typical Application

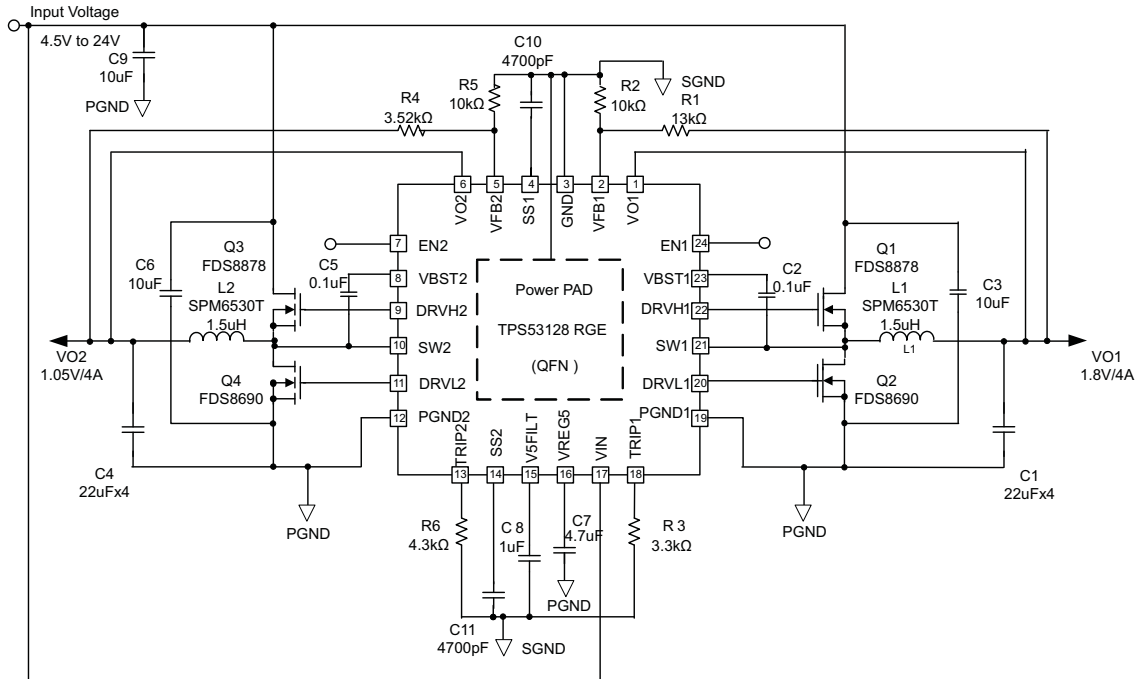

Figure 10. QFN

$$I_{L1(PEAK)} = \frac{V_{TRIP}}{R_{DS(ON)}} + I_{L1(RIPPLE)} \quad (6)$$

$$I_{L1(RMS)} = \sqrt{I_{O1}^2 + \frac{1}{12} (I_{L1(RIPPLE)})^2} \quad (7)$$

Note: The calculation above shall serve as a general reference. To further improve transient response, the output inductance could be reduced further. This needs to be considered along with the selection of the output capacitor.

2. Choose output capacitor.

The capacitor value and ESR determines the amount of output voltage ripple and load transient response. It is recommended to use a ceramic output capacitor.

$$C1 = \frac{I_{L1(RIPPLE)}}{8 \cdot V_{O1(RIPPLE)}} \cdot \frac{1}{f_{SW}} \quad (8)$$

$$C1 = \frac{\Delta I_{load}^2 \cdot L1}{2 \cdot V_{O1} \cdot \Delta V_{OS}} \quad (9)$$

$$C1 = \frac{\Delta I_{load}^2 \cdot L1}{2 \cdot K \cdot \Delta V_{US}} \quad (10)$$

Where

$$K = (V_{IN} - V_{O1}) \cdot \frac{T_{on1}}{T_{on1} + T_{min(off)}} \quad (11)$$

Select the capacitance value greater than the largest value calculated from [Equation 8](#), [Equation 9](#) and [Equation 10](#). The capacitance for C1 should be greater than 66 µF.

Where

ΔV_{OS} = The allowable amount of overshoot voltage in load transition

ΔV_{US} = The allowable amount of undershoot voltage in load transition

$T_{min(off)}$ = Minimum off time

3. Choose input capacitor.

The TPS53128 requires an input decoupling capacitor and a bulk capacitor is needed depending on the application. A minimum 10-µF high-quality ceramic capacitor is recommended for the input capacitor. The capacitor voltage rating needs to be greater than the maximum input voltage.

4. Choose bootstrap capacitor.

The TPS53128 requires a bootstrap capacitor from SW to VBST to provide the floating supply for the high-side drivers. A minimum 0.1-µF high-quality ceramic capacitor is recommended. The voltage rating should be greater than 10 V.

5. Choose VREG5 and V5FILT capacitor.

The TPS53128 requires both the VREG5 regulator and V5FILT input are bypassed. A minimum 4.7-µF high-quality ceramic capacitor must be connected between the VREG5 and GND for proper operation. A minimum 1-µF high-quality ceramic capacitor must be connected between the V5FILT and GND for proper operation. Both of these capacitors' voltage ratings should be greater than 10 V.

6. Choose output voltage divider resistors.

The output voltage is set with a resistor divider from the output voltage node to the VFBx pin. It is recommended to use 1% tolerance or better resistors. Select R2 between 10 kΩ and 100 kΩ and use [Equation 12](#) or [Equation 13](#) to calculate R1.

$$V_{swinj} = (V_{IN} - V_{O1} \cdot 0.5875) \cdot \left(\frac{1}{f_{SW}}\right) \cdot \left(\frac{V_{O1}}{V_{IN}}\right) \cdot 4975 \quad (12)$$

$$R1 = \left(\frac{V_{o1}}{V_{FB} + \frac{V_{FB(RIPPLE)} + V_{swinj}}{2}} - 1 \right) \cdot R2 \quad (13)$$

Where

$V_{FB(RIPPLE)}$ = Ripple voltage at VFB

V_{swinj} = Ripple voltage at error comparator

7. Choose register setting for over current limit.

$$V_{TRIP} = \left(I_{OCL} - \frac{(V_{IN} - V_D)}{2 \cdot L1 \cdot f_{SW}} \cdot \frac{V_O}{V_{IN}} \right) \cdot R_{DS(ON)} \quad (14)$$

$$R_{TRIP} (k\Omega) = \frac{V_{TRIP} (mV) - V_{OCLoff}}{I_{TRIP(min)} (\mu A)} \quad (15)$$

Where

$R_{DS(ON)}$ = Low side FET on-resistance

$I_{TRIP(min)}$ = TRIP pin source current (8.5 μA)

V_{OCLoff} = Minimum over current limit offset voltage (–20 mV)

I_{OCL} = Over current limit

8. Choose soft start capacitor.

Soft start time equation is as follows.

$$C_{SS} = \frac{T_{SS} \cdot I_{SSC}}{V_{FB}} \quad (16)$$

8.2.3 Application Curves

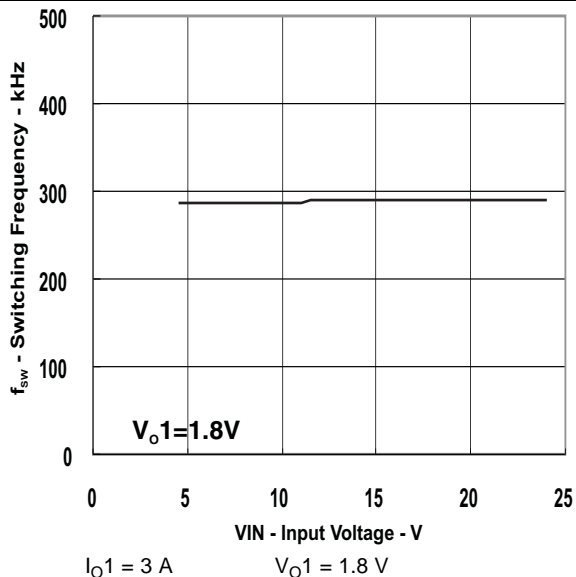

Figure 12. Switching Frequency vs Input Voltage (Ch1)

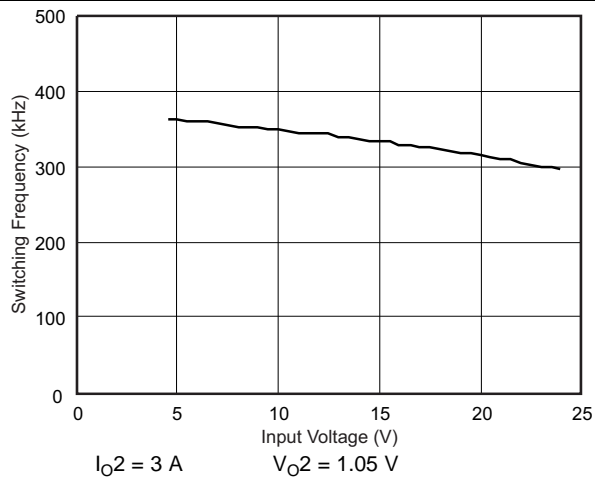

Figure 13. Switching Frequency vs Input Voltage (Ch2)

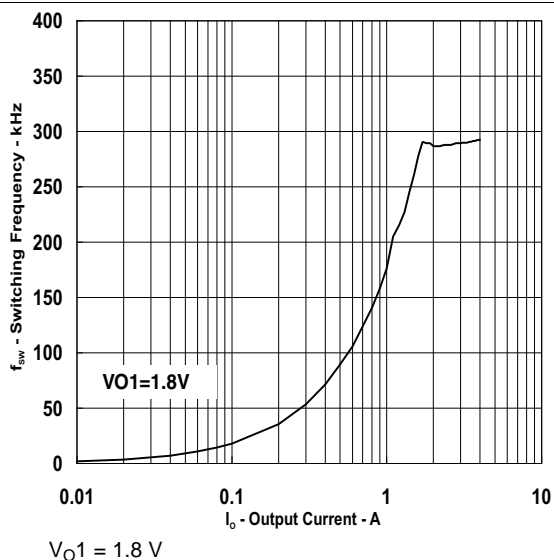

Figure 14. Switching Frequency vs Output Current (Ch1)

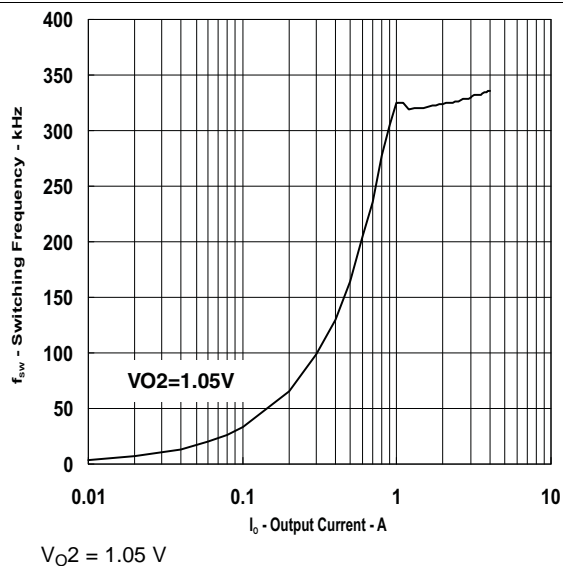

Figure 15. Switching Frequency vs Output Current (Ch2)

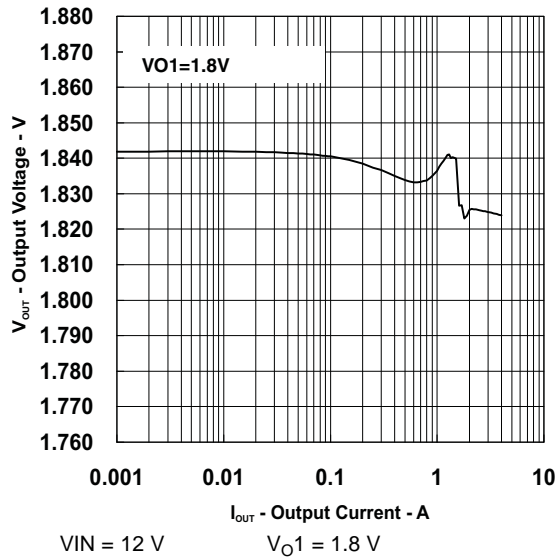

Figure 16. Output Voltage vs Output Current (Ch1)

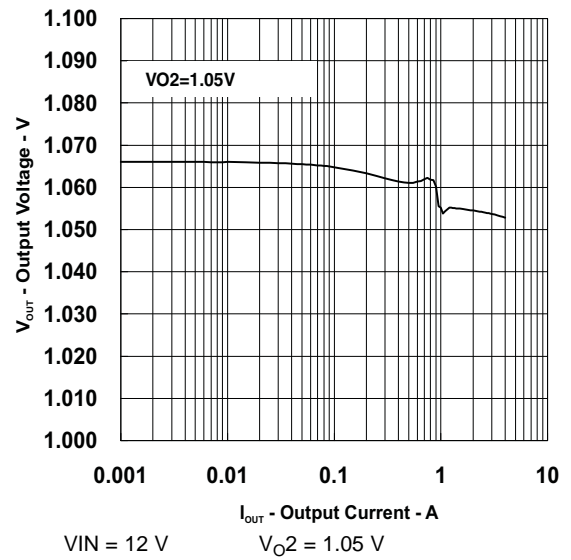

Figure 17. Output Voltage vs Output Current (Ch2)

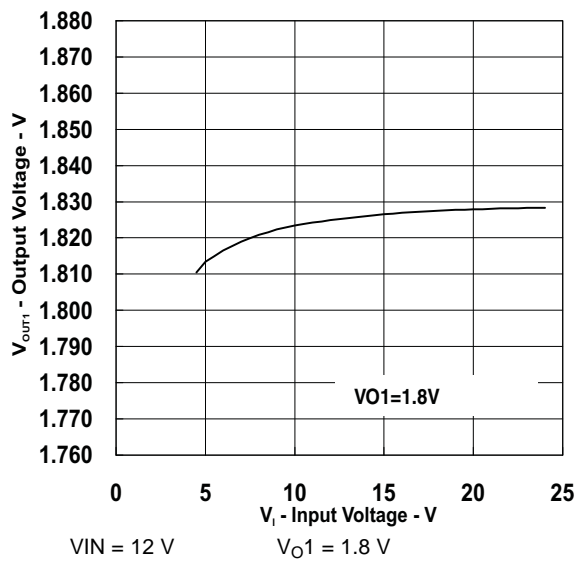

Figure 18. Output Voltage vs Input Voltage (Ch1)

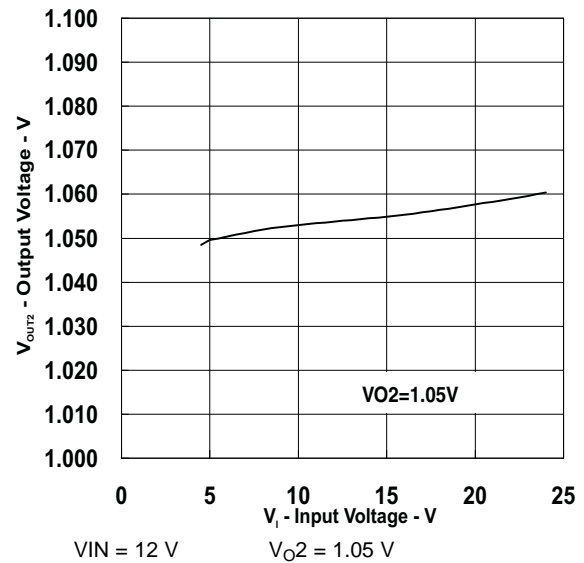

Figure 19. Output Voltage vs Input Voltage (Ch2)

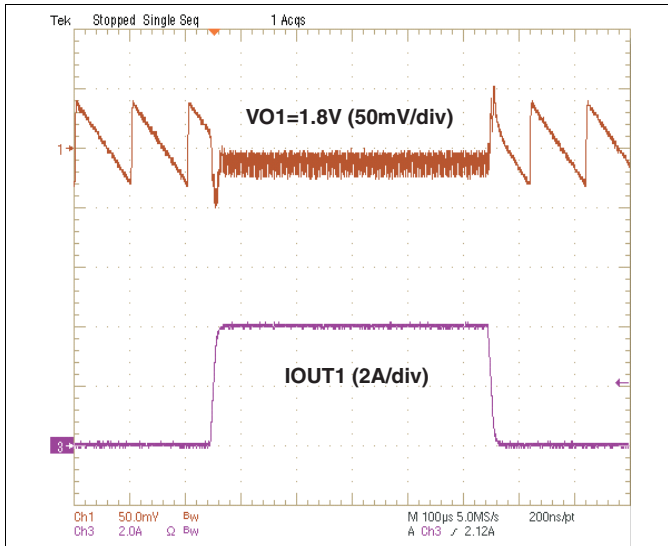

Figure 20. Load Transient Response

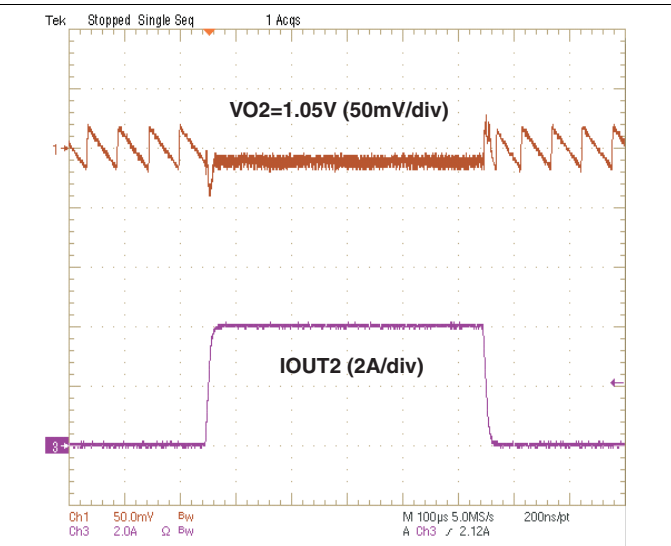

Figure 21. Load Transient Response

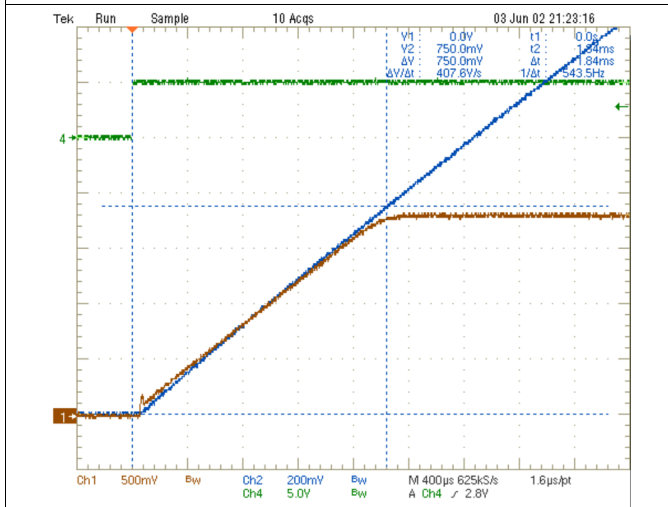

Figure 22. Start-Up Waveforms

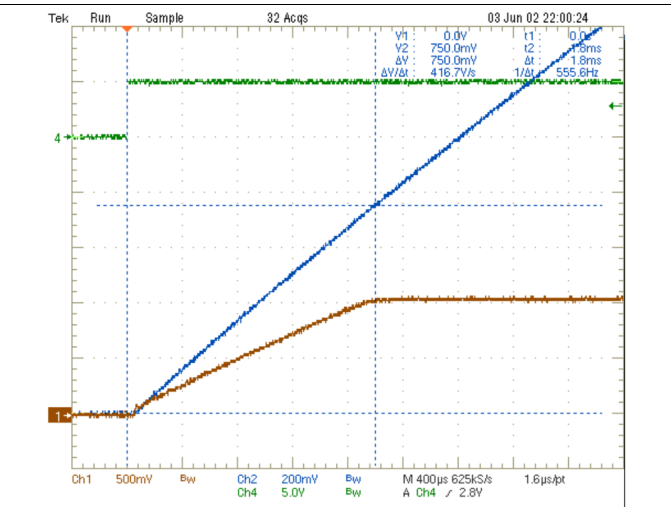

Figure 23. Start-Up Waveforms

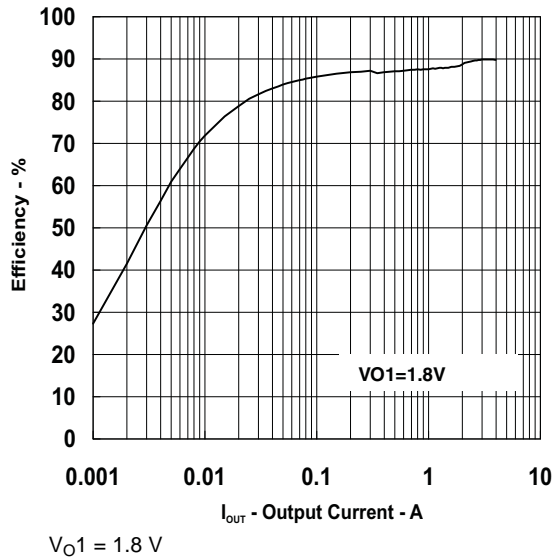

Figure 24. 1.8-V Efficiency vs Output Current (Ch1)

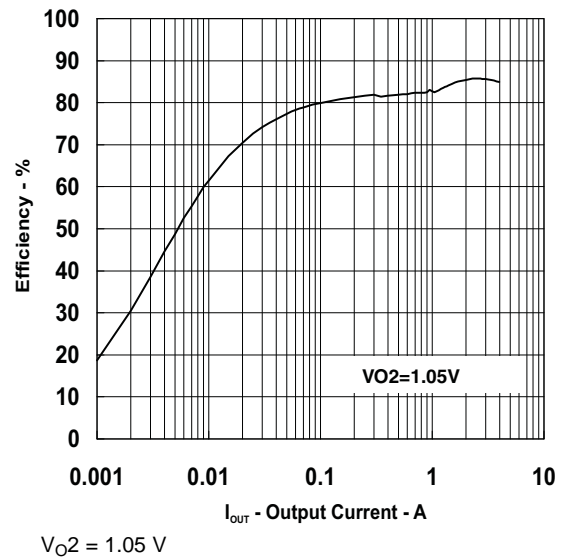

Figure 25. 1.05-V Efficiency vs Output Current (Ch2)

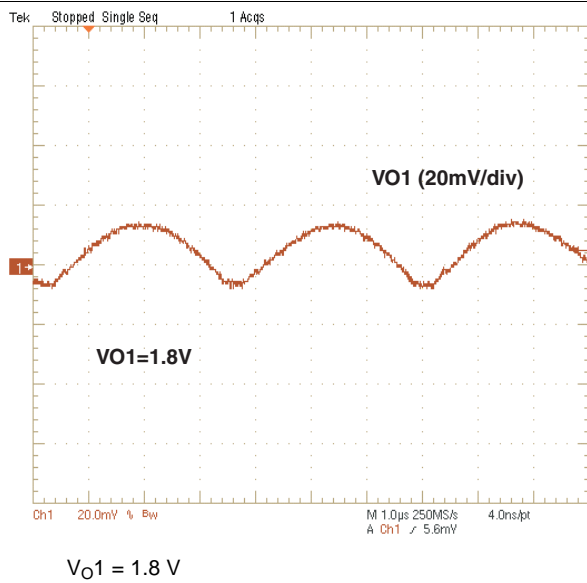

Figure 26. 1.8-V Output Ripple Voltage

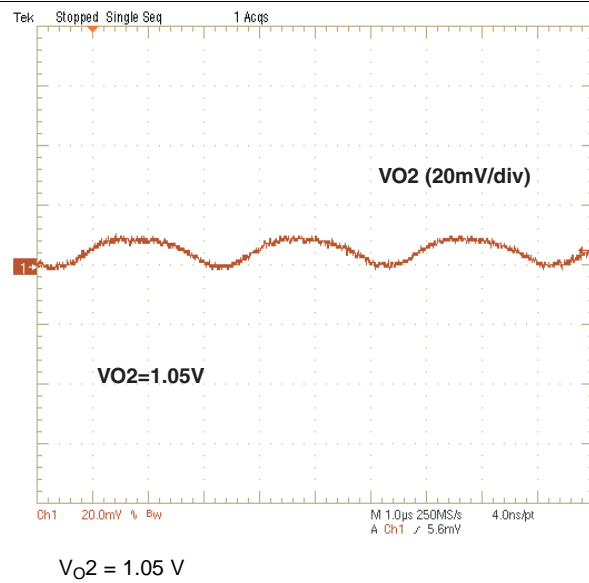

Figure 27. 1.05-V Output Ripple Voltage

9 Power Supply Recommendations

The devices are designed to operate from an input voltage supply range between 4.5 and 24 V. This input supply must be well regulated. If the input supply is located more than a few inches from the TPS53128 device, an additional 0.1 μF ceramic capacitance may be required in addition to the 10 μF of the ceramic bypass capacitors.

10 Layout

10.1 Layout Guidelines

- Keep the input switching current loop as small as possible.
- Place the input capacitor (C3,C6) close to the top switching FET. The output current loop should also be kept as small as possible.
- Keep the SW node as physically small and short as possible as to minimize parasitic capacitance and inductance and to minimize radiated emissions. Kelvin connections should be brought from the output to the feedback pin (FBx) of the device.
- Keep analog and non-switching components away from switching components.
- Make a single point connection from the signal ground to power ground.
- Do not allow switching current to flow under the device.

10.2 Layout Example

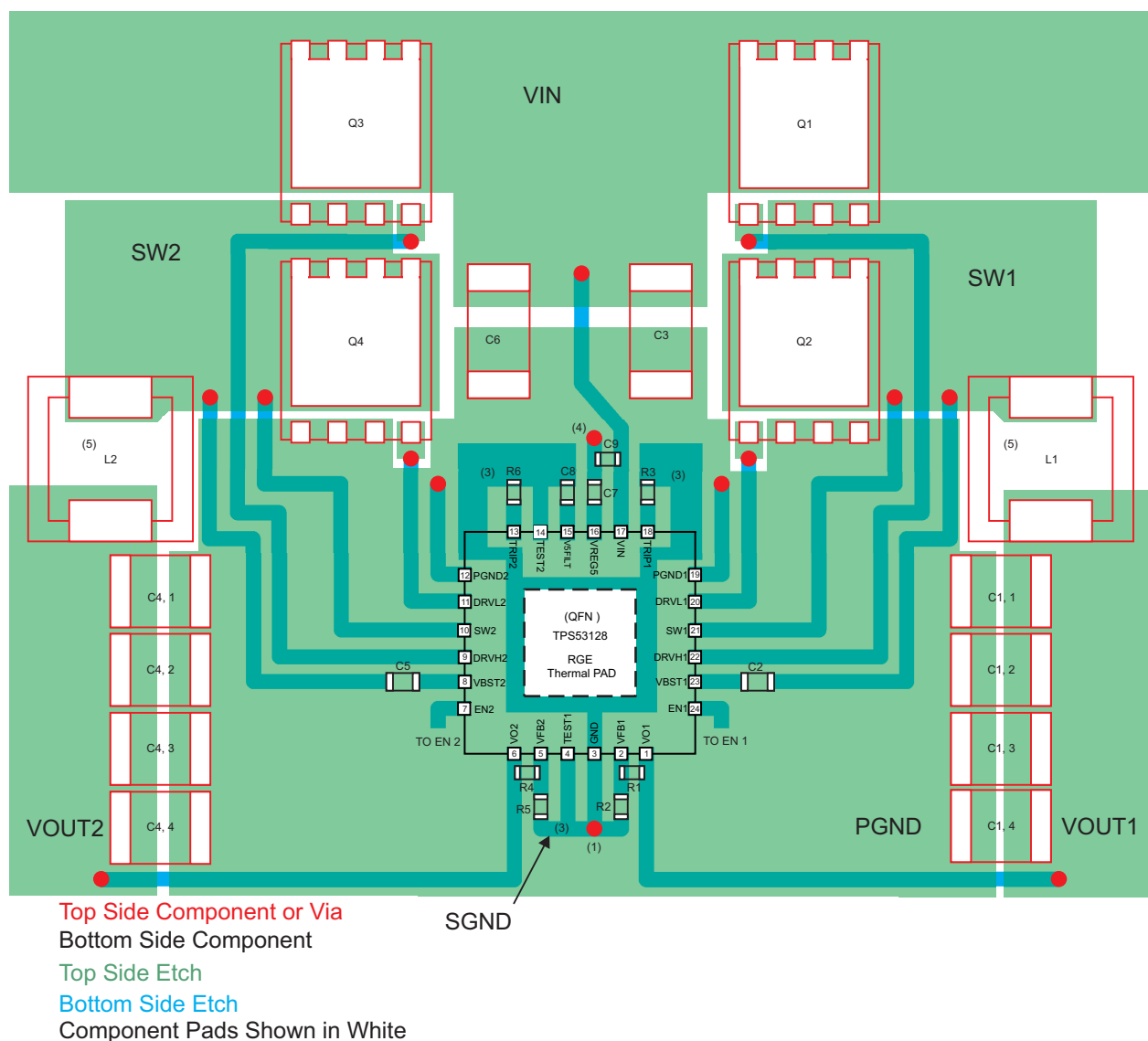

Figure 28.

11 Device and Documentation Support

11.1 Trademarks

D-CAP2, Eco-mode are trademarks of Texas Instruments.
All other trademarks are the property of their respective owners.

11.2 Electrostatic Discharge Caution



These devices have limited built-in ESD protection. The leads should be shorted together or the device placed in conductive foam during storage or handling to prevent electrostatic damage to the MOS gates.

11.3 Glossary

[SLYZ022](#) — *TI Glossary*.

This glossary lists and explains terms, acronyms, and definitions.

12 Mechanical, Packaging, and Orderable Information

The following pages include mechanical, packaging, and orderable information. This information is the most current data available for the designated devices. This data is subject to change without notice and revision of this document. For browser-based versions of this data sheet, refer to the left-hand navigation.

PACKAGING INFORMATION

Orderable Device	Status (1)	Package Type	Package Drawing	Pins	Package Qty	Eco Plan (2)	Lead finish/ Ball material (6)	MSL Peak Temp (3)	Op Temp (°C)	Device Marking (4/5)	Samples
TPS53128PW	ACTIVE	TSSOP	PW	24	60	RoHS & Green	NIPDAU	Level-1-260C-UNLIM	-40 to 85	TPS53128	Samples
TPS53128PWR	ACTIVE	TSSOP	PW	24	2000	RoHS & Green	NIPDAU	Level-1-260C-UNLIM	-40 to 85	TPS53128	Samples
TPS53128RGER	ACTIVE	VQFN	RGE	24	3000	RoHS & Green	NIPDAU	Level-2-260C-1 YEAR	-40 to 85	TPS 53128	Samples
TPS53128RGET	ACTIVE	VQFN	RGE	24	250	RoHS & Green	NIPDAU	Level-2-260C-1 YEAR	-40 to 85	TPS 53128	Samples

(1) The marketing status values are defined as follows:

ACTIVE: Product device recommended for new designs.

LIFEBUY: TI has announced that the device will be discontinued, and a lifetime-buy period is in effect.

NRND: Not recommended for new designs. Device is in production to support existing customers, but TI does not recommend using this part in a new design.

PREVIEW: Device has been announced but is not in production. Samples may or may not be available.

OBSOLETE: TI has discontinued the production of the device.

(2) **RoHS:** TI defines "RoHS" to mean semiconductor products that are compliant with the current EU RoHS requirements for all 10 RoHS substances, including the requirement that RoHS substance do not exceed 0.1% by weight in homogeneous materials. Where designed to be soldered at high temperatures, "RoHS" products are suitable for use in specified lead-free processes. TI may reference these types of products as "Pb-Free".

RoHS Exempt: TI defines "RoHS Exempt" to mean products that contain lead but are compliant with EU RoHS pursuant to a specific EU RoHS exemption.

Green: TI defines "Green" to mean the content of Chlorine (Cl) and Bromine (Br) based flame retardants meet JS709B low halogen requirements of <=1000ppm threshold. Antimony trioxide based flame retardants must also meet the <=1000ppm threshold requirement.

(3) MSL, Peak Temp. - The Moisture Sensitivity Level rating according to the JEDEC industry standard classifications, and peak solder temperature.

(4) There may be additional marking, which relates to the logo, the lot trace code information, or the environmental category on the device.

(5) Multiple Device Markings will be inside parentheses. Only one Device Marking contained in parentheses and separated by a "~" will appear on a device. If a line is indented then it is a continuation of the previous line and the two combined represent the entire Device Marking for that device.

(6) Lead finish/Ball material - Orderable Devices may have multiple material finish options. Finish options are separated by a vertical ruled line. Lead finish/Ball material values may wrap to two lines if the finish value exceeds the maximum column width.

Important Information and Disclaimer: The information provided on this page represents TI's knowledge and belief as of the date that it is provided. TI bases its knowledge and belief on information provided by third parties, and makes no representation or warranty as to the accuracy of such information. Efforts are underway to better integrate information from third parties. TI has taken and

continues to take reasonable steps to provide representative and accurate information but may not have conducted destructive testing or chemical analysis on incoming materials and chemicals. TI and TI suppliers consider certain information to be proprietary, and thus CAS numbers and other limited information may not be available for release.

In no event shall TI's liability arising out of such information exceed the total purchase price of the TI part(s) at issue in this document sold by TI to Customer on an annual basis.

TAPE AND REEL INFORMATION

QUADRANT ASSIGNMENTS FOR PIN 1 ORIENTATION IN TAPE

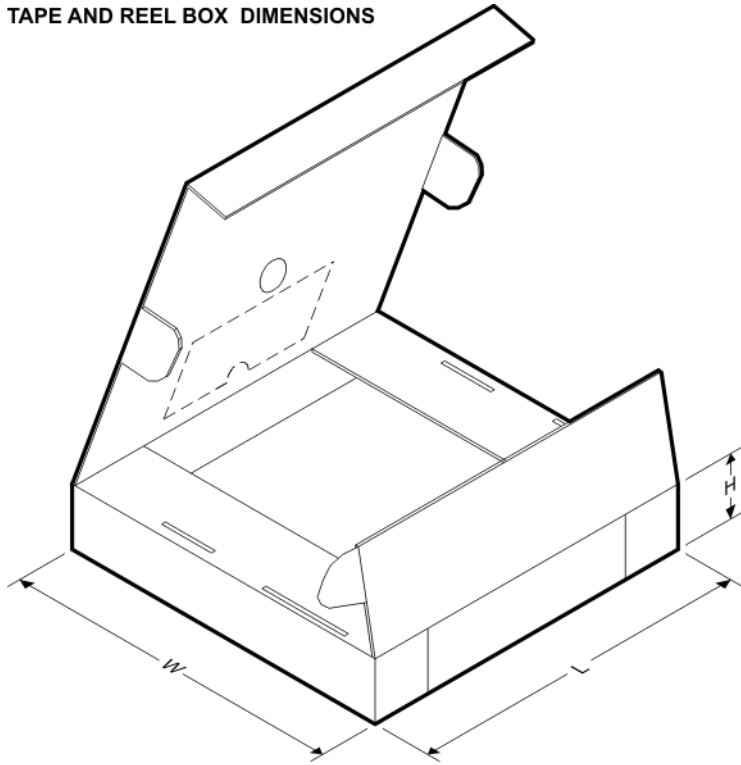

*All dimensions are nominal

Device	Package Type	Package Drawing	Pins	SPQ	Reel Diameter (mm)	Reel Width W1 (mm)	A0 (mm)	B0 (mm)	K0 (mm)	P1 (mm)	W (mm)	Pin1 Quadrant
TPS53128PWR	TSSOP	PW	24	2000	330.0	16.4	6.95	8.3	1.6	8.0	16.0	Q1
TPS53128RGER	VQFN	RGE	24	3000	330.0	12.4	4.25	4.25	1.15	8.0	12.0	Q2
TPS53128RGET	VQFN	RGE	24	250	180.0	12.4	4.25	4.25	1.15	8.0	12.0	Q2

TAPE AND REEL BOX DIMENSIONS

*All dimensions are nominal

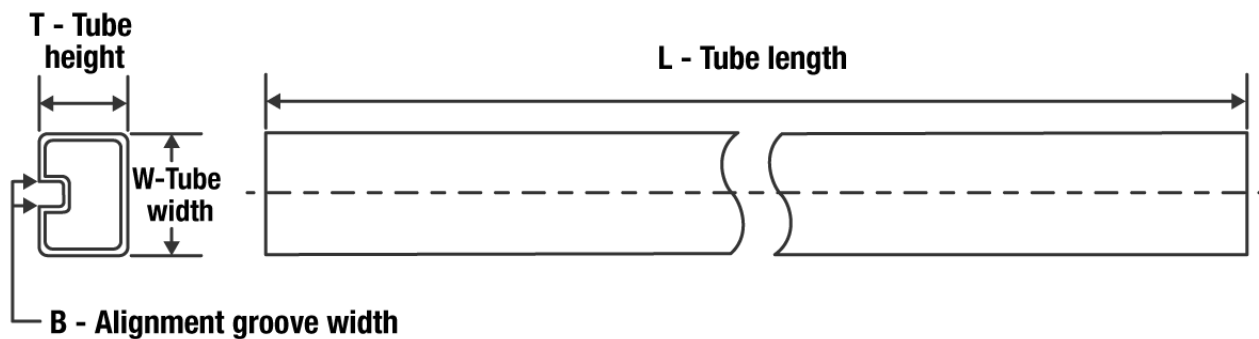
Device	Package Type	Package Drawing	Pins	SPQ	Length (mm)	Width (mm)	Height (mm)
TPS53128PWR	TSSOP	PW	24	2000	853.0	449.0	35.0
TPS53128RGER	VQFN	RGE	24	3000	853.0	449.0	35.0
TPS53128RGET	VQFN	RGE	24	250	210.0	185.0	35.0

TUBE

*All dimensions are nominal

Device	Package Name	Package Type	Pins	SPQ	L (mm)	W (mm)	T (μm)	B (mm)
TPS53128PW	PW	TSSOP	24	60	530	10.2	3600	3.5

RGE 24

GENERIC PACKAGE VIEW

VQFN - 1 mm max height

PLASTIC QUAD FLATPACK - NO LEAD

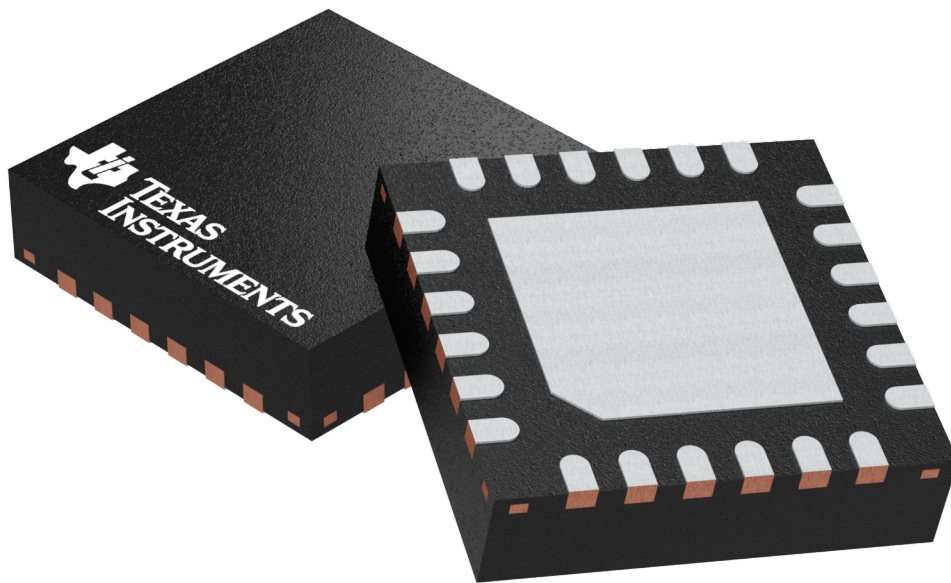

Images above are just a representation of the package family, actual package may vary.
Refer to the product data sheet for package details.

4204104/H

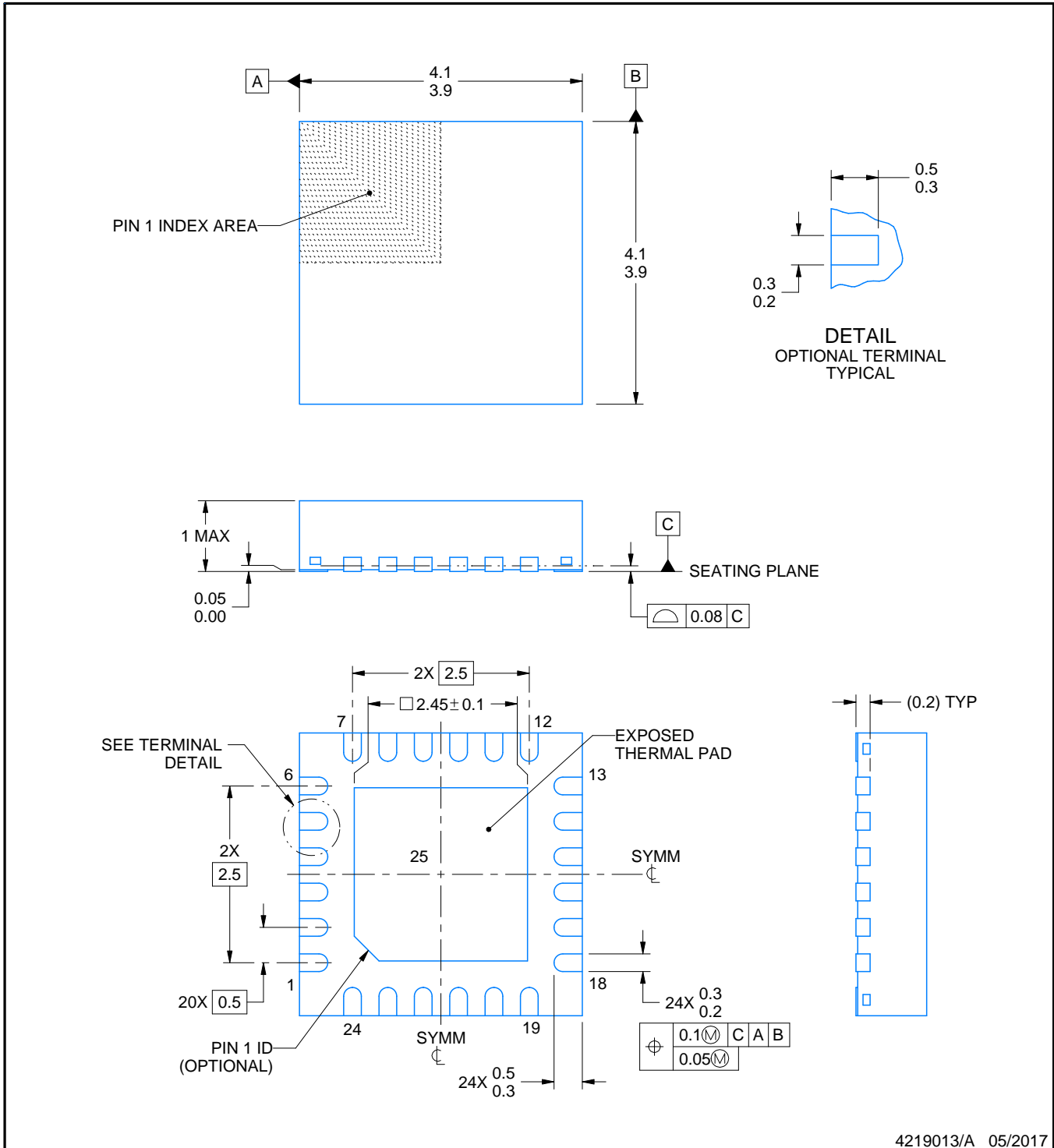
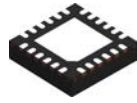

4219013/A 05/2017

NOTES:

1. All linear dimensions are in millimeters. Any dimensions in parenthesis are for reference only. Dimensioning and tolerancing per ASME Y14.5M.
2. This drawing is subject to change without notice.
3. The package thermal pad must be soldered to the printed circuit board for thermal and mechanical performance.

EXAMPLE STENCIL DESIGN

RGE0024B

VQFN - 1 mm max height

PLASTIC QUAD FLATPACK - NO LEAD

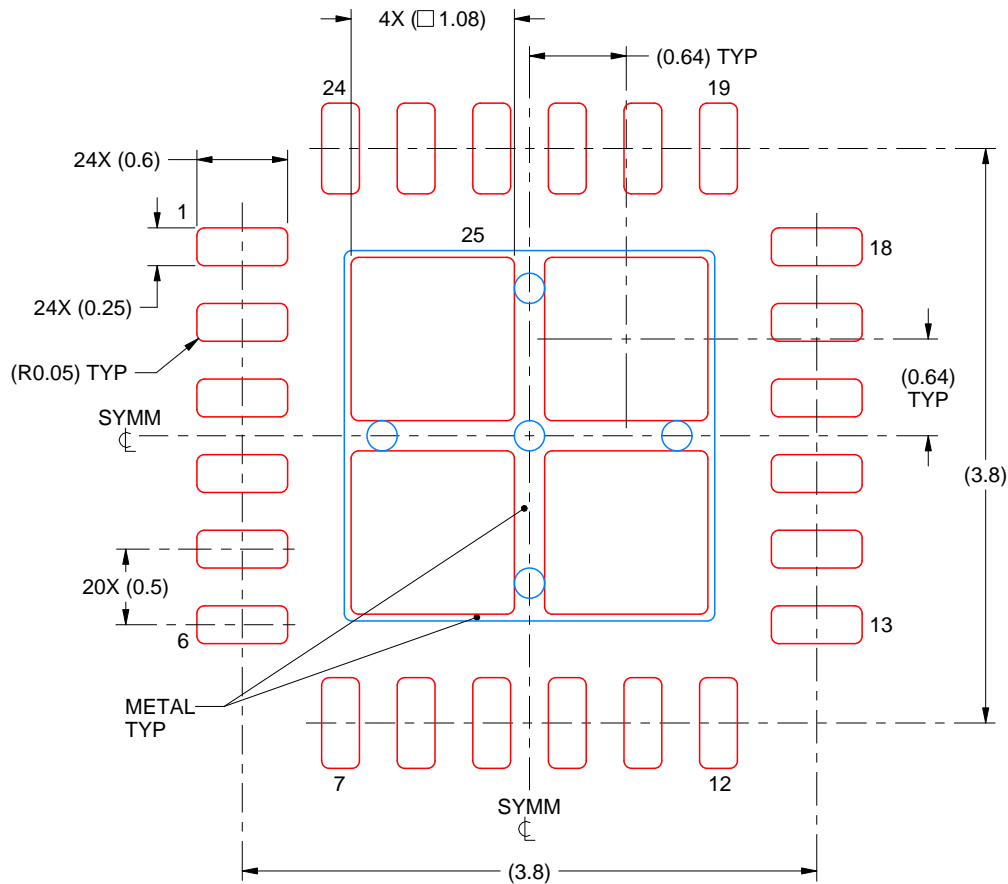

SOLDER PASTE EXAMPLE
 BASED ON 0.125 mm THICK STENCIL

EXPOSED PAD 25
 78% PRINTED SOLDER COVERAGE BY AREA UNDER PACKAGE
 SCALE:20X

4219013/A 05/2017

NOTES: (continued)

- 6. Laser cutting apertures with trapezoidal walls and rounded corners may offer better paste release. IPC-7525 may have alternate design recommendations.

PW0024A

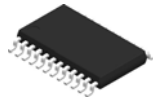

PACKAGE OUTLINE

TSSOP - 1.2 mm max height

SMALL OUTLINE PACKAGE

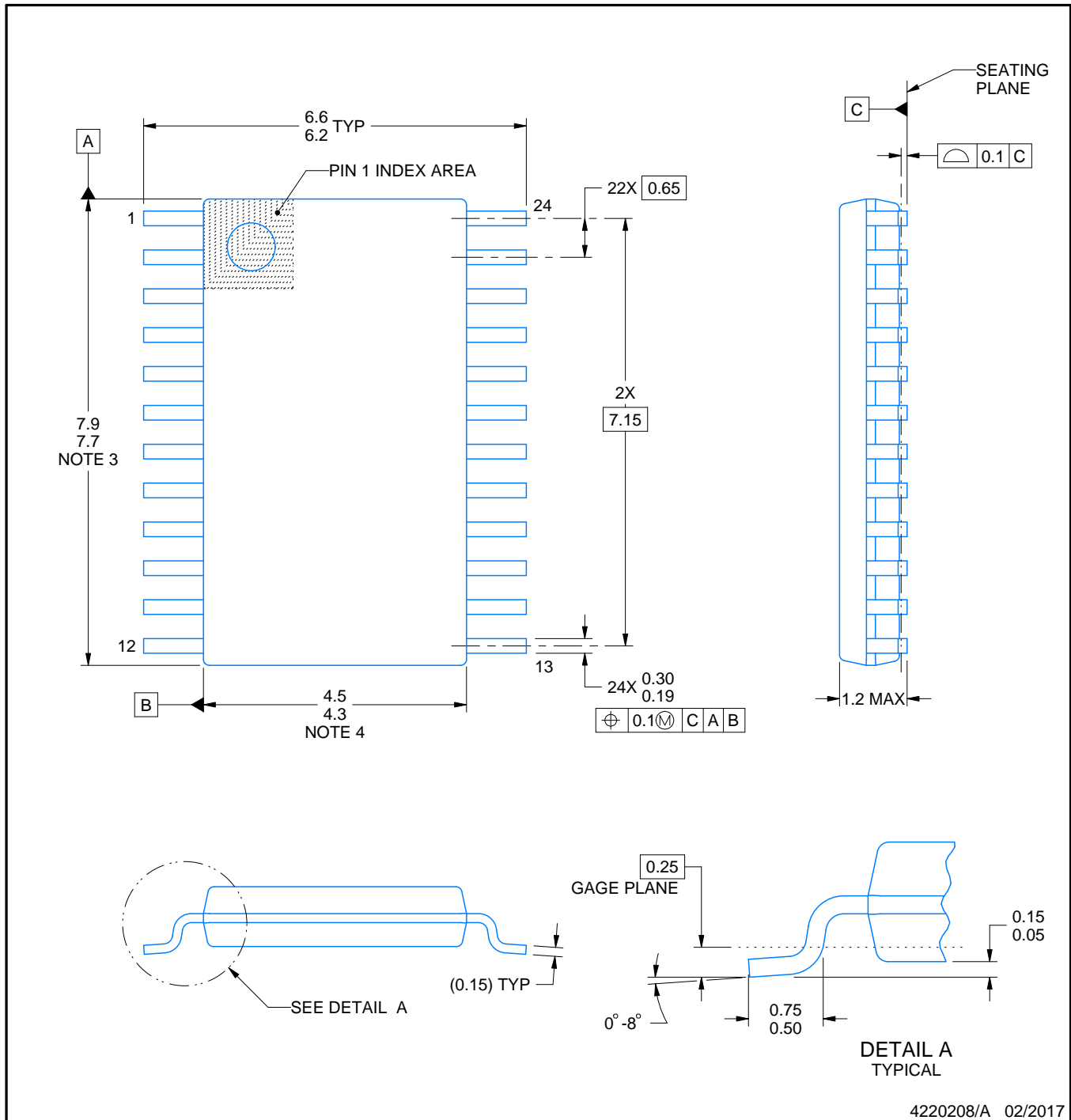

4220208/A 02/2017

NOTES:

1. All linear dimensions are in millimeters. Any dimensions in parenthesis are for reference only. Dimensioning and tolerancing per ASME Y14.5M.
2. This drawing is subject to change without notice.
3. This dimension does not include mold flash, protrusions, or gate burrs. Mold flash, protrusions, or gate burrs shall not exceed 0.15 mm per side.
4. This dimension does not include interlead flash. Interlead flash shall not exceed 0.25 mm per side.
5. Reference JEDEC registration MO-153.

EXAMPLE BOARD LAYOUT

PW0024A

TSSOP - 1.2 mm max height

SMALL OUTLINE PACKAGE

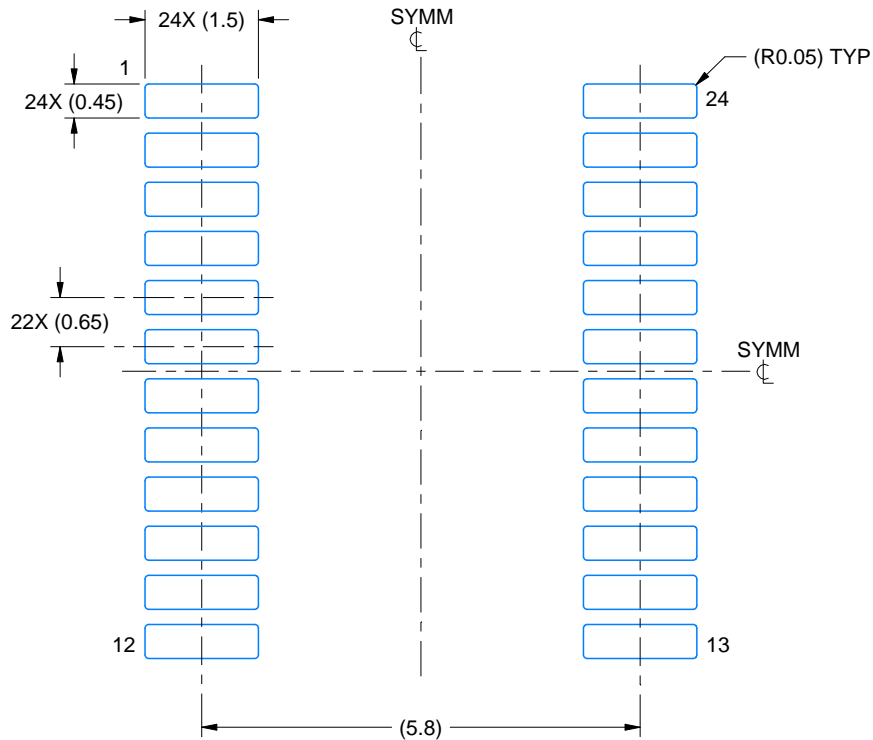

LAND PATTERN EXAMPLE
EXPOSED METAL SHOWN
SCALE: 10X

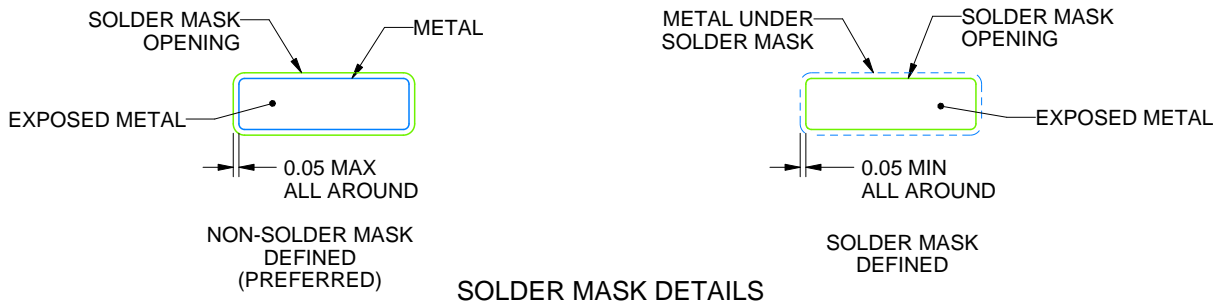

SOLDER MASK DETAILS

4220208/A 02/2017

NOTES: (continued)

- 6. Publication IPC-7351 may have alternate designs.
- 7. Solder mask tolerances between and around signal pads can vary based on board fabrication site.

EXAMPLE STENCIL DESIGN

PW0024A

TSSOP - 1.2 mm max height

SMALL OUTLINE PACKAGE

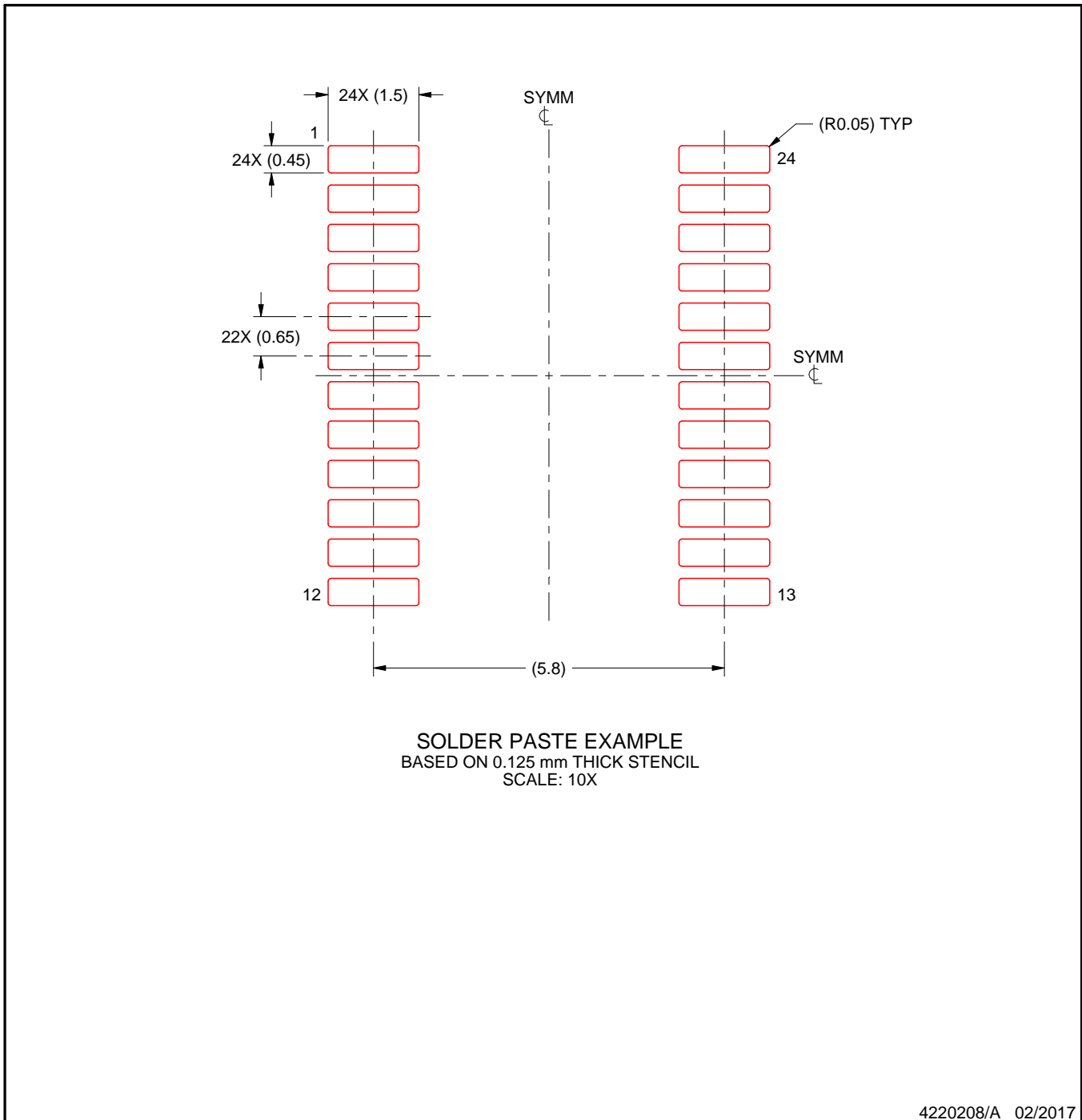

NOTES: (continued)

8. Laser cutting apertures with trapezoidal walls and rounded corners may offer better paste release. IPC-7525 may have alternate design recommendations.
9. Board assembly site may have different recommendations for stencil design.

IMPORTANT NOTICE AND DISCLAIMER

TI PROVIDES TECHNICAL AND RELIABILITY DATA (INCLUDING DATA SHEETS), DESIGN RESOURCES (INCLUDING REFERENCE DESIGNS), APPLICATION OR OTHER DESIGN ADVICE, WEB TOOLS, SAFETY INFORMATION, AND OTHER RESOURCES "AS IS" AND WITH ALL FAULTS, AND DISCLAIMS ALL WARRANTIES, EXPRESS AND IMPLIED, INCLUDING WITHOUT LIMITATION ANY IMPLIED WARRANTIES OF MERCHANTABILITY, FITNESS FOR A PARTICULAR PURPOSE OR NON-INFRINGEMENT OF THIRD PARTY INTELLECTUAL PROPERTY RIGHTS.

These resources are intended for skilled developers designing with TI products. You are solely responsible for (1) selecting the appropriate TI products for your application, (2) designing, validating and testing your application, and (3) ensuring your application meets applicable standards, and any other safety, security, regulatory or other requirements.

These resources are subject to change without notice. TI grants you permission to use these resources only for development of an application that uses the TI products described in the resource. Other reproduction and display of these resources is prohibited. No license is granted to any other TI intellectual property right or to any third party intellectual property right. TI disclaims responsibility for, and you will fully indemnify TI and its representatives against, any claims, damages, costs, losses, and liabilities arising out of your use of these resources.

TI's products are provided subject to [TI's Terms of Sale](#) or other applicable terms available either on ti.com or provided in conjunction with such TI products. TI's provision of these resources does not expand or otherwise alter TI's applicable warranties or warranty disclaimers for TI products.

TI objects to and rejects any additional or different terms you may have proposed.

Mailing Address: Texas Instruments, Post Office Box 655303, Dallas, Texas 75265
Copyright © 2022, Texas Instruments Incorporated