



Dual, Wideband, Voltage-Feedback OPERATIONAL AMPLIFIER with Disable

Check for Samples: [OPA2690](#)

FEATURES

- **FLEXIBLE SUPPLY RANGE:**
 +5V to +12V Single Supply
 ±2.5V to ±6V Dual Supply
- **WIDEBAND +5V OPERATION: 220MHz (G = 2)**
- **HIGH OUTPUT CURRENT: 190mA**
- **OUTPUT VOLTAGE SWING: ±4.0V**
- **HIGH SLEW RATE: 1800V/μs**
- **LOW SUPPLY CURRENT: 5.5mA/ch**
- **LOW DISABLE CURRENT: 100μA/ch**

APPLICATIONS

- VIDEO LINE DRIVING
- xDSL LINE DRIVER/RECEIVER
- HIGH-SPEED IMAGING CHANNELS
- ADC BUFFERS
- PORTABLE INSTRUMENTS
- TRANSIMPEDANCE AMPLIFIERS
- ACTIVE FILTERS

Single-Supply Differential ADC Driver

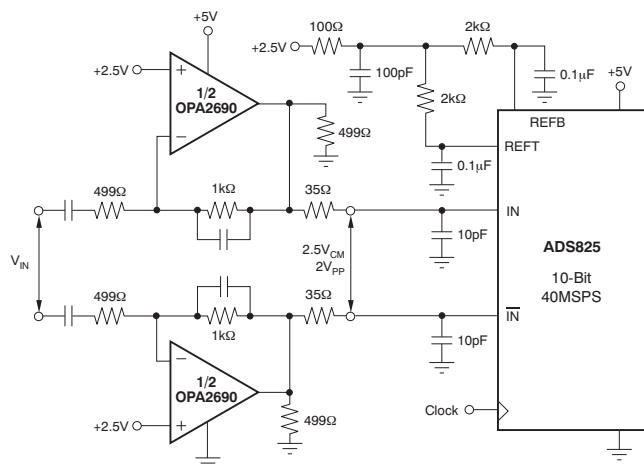

DESCRIPTION

The OPA2690 represents a major step forward in unity-gain stable, voltage-feedback op amps. A new internal architecture provides slew rate and full-power bandwidth previously found only in wideband, current-feedback op amps. A new output stage architecture delivers high currents with a minimal headroom requirement. These give exceptional single-supply operation. Using a single +5V supply, the OPA2690 can deliver a 1V to 4V output swing with over 120mA drive current and 150MHz bandwidth. This combination of features makes the OPA2690 an ideal RGB line driver or single-supply Analog-to-Digital Converter (ADC) input driver.

The low 5.5mA/ch supply current of the OPA2690 is precisely trimmed at +25°C. This trim, along with low temperature drift, provides lower maximum supply current than competing products. System power may be reduced further using the optional disable control pin. Leaving this disable pin open, or holding it HIGH, will operate the OPA2690I-14D normally. If pulled LOW, the OPA2690I-14D supply current drops to less than 200μA/ch while the output goes to a high-impedance state.

OPA2690 RELATED PRODUCTS

	SINGLES	DUALS	TRIPLES
Voltage-Feedback	OPA690	OPA2690	OPA3690
Current-Feedback	OPA691	OPA2691	OPA3691
Fixed Gain	OPA692	—	OPA3692

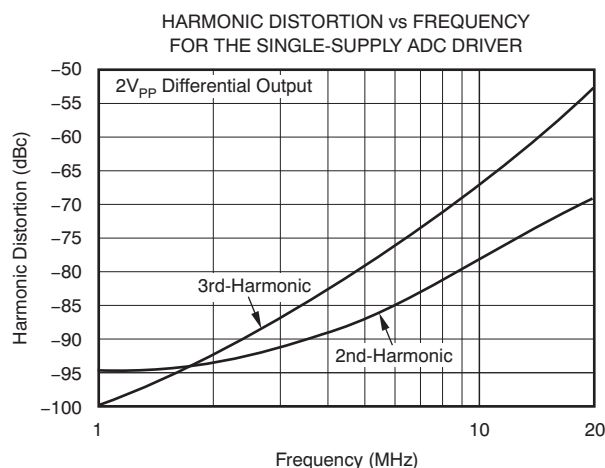

Please be aware that an important notice concerning availability, standard warranty, and use in critical applications of Texas Instruments semiconductor products and disclaimers thereto appears at the end of this data sheet.

All trademarks are the property of their respective owners.



This integrated circuit can be damaged by ESD. Texas Instruments recommends that all integrated circuits be handled with appropriate precautions. Failure to observe proper handling and installation procedures can cause damage.

ESD damage can range from subtle performance degradation to complete device failure. Precision integrated circuits may be more susceptible to damage because very small parametric changes could cause the device not to meet its published specifications.

ORDERING INFORMATION⁽¹⁾

PRODUCT	PACKAGE-LEAD	PACKAGE DESIGNATOR	SPECIFIED TEMPERATURE RANGE	PACKAGE MARKING	ORDERING NUMBER	TRANSPORT MEDIA, QUANTITY
OPA2690	SO-8	D	-40°C to +85°C	OPA2690	OPA2690ID	Rails, 100
					OPA2690IDR	Tape and Reel, 2500
OPA2690	SO-14	D	-40°C to +85°C	OPA2690	OPA2690I-14D	Rails, 58
					OPA2690I-14DR	Tape and Reel, 2500

(1) For the most current package and ordering information, see the Package Option Addendum located at the end of this data sheet, or see the TI web site at www.ti.com.

ABSOLUTE MAXIMUM RATINGS⁽¹⁾

Over operating free-air temperature range, unless otherwise noted.

	OPA2690	UNIT
Power Supply	±6.5	V _{DC}
Internal Power Dissipation	See Thermal Analysis section	
Differential Input Voltage	±1.2	V
Input Voltage Range	±V _S	V
Storage Temperature Range: D	-65 to +125	°C
Junction Temperature (T _J)	+150	°C
ESD Ratings	Human Body Model (HBM)	2000
	Charge Device Model (CDM)	1500
	Machine Model (MM)	200

(1) Stresses above these ratings may cause permanent damage. Exposure to absolute maximum conditions for extended periods may degrade device reliability. These are stress ratings only, and functional operation of the device at these or any other conditions beyond those specified is not supported.

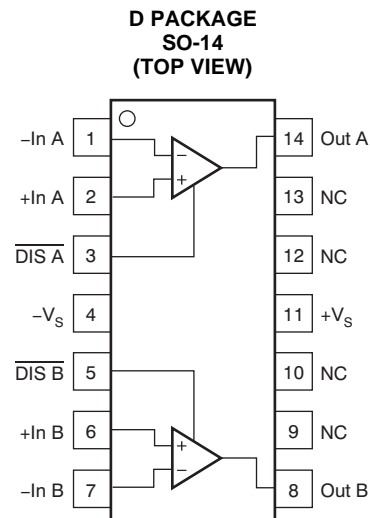
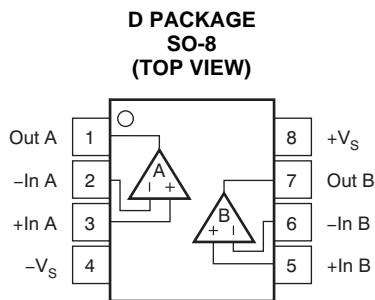

ELECTRICAL CHARACTERISTICS: $V_S = \pm 5V$
Boldface limits are tested at **+25°C**.

At $R_F = 402\Omega$, $R_L = 100\Omega$, and $G = +2$ (see [Figure 36](#) for ac performance only), unless otherwise noted.

PARAMETER	TEST CONDITIONS	OPA2690ID, I-14D						TEST LEVELS ⁽¹⁾	
		TYP	MIN/MAX OVER TEMPERATURE				UNIT		MIN/MAX
		+25°C	+25°C ⁽²⁾	0°C to +70°C ⁽³⁾	-40°C to +85°C ⁽³⁾				
AC PERFORMANCE (see Figure 36)									
Small-Signal Bandwidth	$G = +1, V_O = 0.5V_{PP}, R_F = 25\Omega$	500					MHz	typ	C
	$G = +2, V_O = 0.5V_{PP}$	220	165	160	150		MHz	min	B
	$G = +10, V_O = 0.5V_{PP}$	30	20	19	18		MHz	min	B
Gain Bandwidth Product	$G \geq 10$	300	200	190	180		MHz	min	B
Bandwidth for 0.1dB Gain Flatness	$G = +2, V_O < 0.5V_{PP}$	30					MHz	typ	C
Peaking at a Gain of +1	$V_O < 0.5V_{PP}$	4					dB	typ	C
Large-Signal Bandwidth	$G = +2, V_O < 5V_{PP}$	200					MHz	typ	C
Slew Rate	$G = +2, 4V$ Step	1800	1400	1200	900		V/ μ s	min	B
Rise-and-Fall Time	$G = +2, V_O = 0.5V$ Step	1.4					ns	typ	C
	$G = +2, V_O = 5V$ Step	2.8					ns	typ	C
Settling Time to 0.02%	$G = +2, V_O = 5V$ Step	12					ns	typ	C
Settling Time to 0.1%	$G = +2, V_O = 5V$ Step	8					ns	typ	C
Harmonic Distortion	$G = +2, f = 5MHz, V_O = 2V_{PP}$								
2nd-Harmonic	$R_L = 100\Omega$	-68	-64	-62	-60		dBc	max	B
	$R_L \geq 500\Omega$	-77	-70	-68	-66		dBc	max	B
3rd-Harmonic	$R_L = 100\Omega$	-70	-68	-66	-64		dBc	max	B
	$R_L \geq 500\Omega$	-81	-78	-76	-75		dBc	max	B
Input Voltage Noise	$f > 1MHz$	5.5					nV/ \sqrt{Hz}	typ	C
Input Current Noise	$f > 1MHz$	3.1					pA/ \sqrt{Hz}	typ	C
Differential Gain	$G = +2, NTSC, V_O = 1.4V_P, R_L = 150\Omega$	0.06					%	typ	C
Differential Phase	$G = +2, NTSC, V_O = 1.4V_P, R_L = 150\Omega$	0.03					deg	typ	C
Channel-to-Channel Crosstalk	$f = 5MHz, Input-Referred$	-85					dBc	typ	C
DC PERFORMANCE⁽⁴⁾									
Open-Loop Voltage Gain (A_{OL})	$V_O = 0V, R_L = 100\Omega$	69	58	56	54		dB	min	A
Input Offset Voltage	$V_{CM} = 0V$	± 1.0	± 4.5	± 5.0	± 5.2		mV	max	A
Average Offset Voltage Drift	$V_{CM} = 0V$			± 12	± 12		$\mu V/^\circ C$	max	B
Input Bias Current	$V_{CM} = 0V$	+5	± 11	± 12	± 13		μA	max	A
Average Bias Current Drift (magnitude)	$V_{CM} = 0V$			± 20	± 40		nA/ $^\circ C$	max	B
Input Offset Current	$V_{CM} = 0V$	± 0.1	± 1.0	± 1.4	± 1.6		μA	max	A
Average Offset Current Drift	$V_{CM} = 0V$			± 1.0	± 1.5		nA/ $^\circ C$	max	B
INPUT									
Common-Mode Input Range (CMIR) ⁽⁵⁾		± 3.5	± 3.4	± 3.3	± 3.2		V	min	A
Common-Mode Rejection Ratio (CMRR)	$V_{CM} = \pm 1V$	65	60	57	56		dB	min	A
Input Impedance									
Differential Mode	$V_{CM} = 0V$	190 0.6					k Ω pF	typ	C
Common-Mode	$V_{CM} = 0V$	3.2 0.9					M Ω pF	typ	C

- (1) Test levels: **(A)** 100% tested at +25°C. Over temperature limits by characterization and simulation. **(B)** Limits set by characterization and simulation. **(C)** Typical value only for information.
- (2) Junction temperature = ambient for +25°C specifications.
- (3) Junction temperature = ambient at low temperature limits; junction temperature = ambient +15°C at high temperature limit for over temperature specifications.
- (4) Current is considered positive out of node. V_{CM} is the input common-mode voltage.
- (5) Tested < 3dB below minimum specified CMRR at \pm CMIR limits.

ELECTRICAL CHARACTERISTICS: $V_S = \pm 5V$ (continued)**Boldface** limits are tested at **+25°C**.At $R_F = 402\Omega$, $R_L = 100\Omega$, and $G = +2$ (see [Figure 36](#) for ac performance only), unless otherwise noted.

PARAMETER	TEST CONDITIONS	OPA2690ID, I-14D						TEST LEVELS ⁽¹⁾	
		TYP	MIN/MAX OVER TEMPERATURE				UNIT		MIN/MAX
			+25°C	+25°C ⁽²⁾	0°C to +70°C ⁽³⁾	-40°C to +85°C ⁽³⁾			
OUTPUT									
Voltage Output Swing	No Load	±4.0	±3.8	±3.7	±3.6	V	min	A	
	100Ω Load	±3.9	±3.7	±3.6	±3.3	V	min	A	
Current Output, Sourcing	$V_O = 0V$	+190	+160	+140	+100	mA	min	A	
Current Output, Sinking	$V_O = 0V$	-190	-160	-140	-100	mA	min	A	
Short-Circuit Current	$V_O = 0V$	±250				mA	typ	C	
Closed-Loop Output Impedance	$G = +2$, $f = 100kHz$	0.04				Ω	typ	C	
DISABLE (SO-14 Only)									
Power-Down Supply Current ($+V_S$)	Disabled LOW $V_{DIS} = 0V$, Both Channels	-200	-400	-480	-520	μA	max	A	
Disable Time	$V_{IN} = 1V_{DC}$	200				ns	typ	C	
Enable Time	$V_{IN} = 1V_{DC}$	25				ns	typ	C	
Off Isolation	$G = +2$, $R_L = 150\Omega$, $V_{IN} = 0V$	70				dB	typ	C	
Output Capacitance in Disable	$G = +2$, $R_L = 150\Omega$, $V_{IN} = 0V$	4				pF	typ	C	
Turn-On Glitch		±50				mV	typ	C	
Turn-Off Glitch		±20				mV	typ	C	
Enable Voltage		3.3	3.5	3.6	3.7	V	min	A	
Disable Voltage		1.8	1.7	1.6	1.5	V	max	A	
Control Pin Input Bias Current (V_{DIS})	$V_{DIS} = 0V$, Each Channel	75	130	150	160	μA	max	A	
POWER SUPPLY									
Specified Operating Voltage		±5				V	typ	C	
Maximum Operating Voltage Range			±6.0	±6.0	±6.0	V	max	A	
Maximum Quiescent Current (2 Channels)	$V_S = \pm 5V$	11	11.6	12.4	13.2	mA	max	A	
Minimum Quiescent Current (2 Channels)	$V_S = \pm 5V$	11	10.6	9.2	8.6	mA	min	A	
Power-Supply Rejection Ratio (+PSRR)	Input-Referred	75	68	66	64	dB	min	A	
THERMAL CHARACTERISTICS									
Specified Operating Range: D		-40 to +85				°C	typ	C	
Thermal Resistance, θ_{JA}	Junction-to-Ambient								
D SO-8		125				°C/W	typ	C	
D SO-14		100				°C/W	typ	C	

ELECTRICAL CHARACTERISTICS: $V_S = +5V$
Boldface limits are tested at **+25°C**.

 At $R_F = 402\Omega$, $R_L = 100\Omega$ to $V_S/2$, and $G = +2$ (see [Figure 37](#) for ac performance only), unless otherwise noted.

PARAMETER	TEST CONDITIONS	OPA2690ID, I-14D						TEST LEVELS ⁽¹⁾	
		TYP	MIN/MAX OVER TEMPERATURE				UNIT		MIN/MAX
		+25°C	+25°C ⁽²⁾	0°C to +70°C ⁽³⁾	-40°C to +85°C ⁽³⁾				
AC PERFORMANCE (see Figure 37)									
Small-Signal Bandwidth	$G = +1, V_O = 0.5V_{PP}, R_F = \pm 25\Omega$	400				MHz	typ	C	
	$G = +2, V_O < 0.5V_{PP}$	190	150	145	140	MHz	min	B	
	$G = +10, V_O < 0.5V_{PP}$	25	18	17	16	MHz	min	B	
Gain Bandwidth Product	$G \geq 10$	250	180	170	160	MHz	min	B	
Bandwidth for 0.1dB Gain Flatness	$G = +2, V_O < 0.5V_{PP}$	20				MHz	typ	C	
Peaking at a Gain of +1	$V_O < 0.5V_{PP}$	5				dB	typ	C	
Large-Signal Bandwidth	$G = +2, V_O = 2V_{PP}$	220				MHz	typ	C	
Slew Rate	$G = +2, 2V$ Step	1000	700	670	550	V/ μ s	min	B	
Rise-and-Fall Time	$G = +2, V_O = 0.5V$ Step	1.6				ns	typ	C	
	$G = +2, V_O = 2V$ Step	2.0				ns	typ	C	
Settling Time to 0.02%	$G = +2, V_O = 2V$ Step	12				ns	typ	C	
Settling Time to 0.1%	$G = +2, V_O = 2V$ Step	8				ns	typ	C	
Harmonic Distortion	$G = +2, f = 5MHz, V_O = 2V_{PP}$								
2nd-Harmonic	$R_L = 100\Omega$ to $V_S/2$	-65	-60	-59	-56	dBc	max	B	
	$R_L \geq 500\Omega$ to $V_S/2$	-75	-70	-68	-66	dBc	max	B	
3rd-Harmonic	$R_L = 100\Omega$ to $V_S/2$	-68	-64	-62	-60	dBc	max	B	
	$R_L \geq 500\Omega$ to $V_S/2$	-77	-73	-71	-70	dBc	max	B	
Input Voltage Noise	$f > 1MHz$	5.6				nV/ \sqrt{Hz}	typ	C	
Input Current Noise	$f > 1MHz$	3.2				pA/ \sqrt{Hz}	typ	C	
Differential Gain	$G = +2, NTSC, V_O = 1.4V_P, R_L = 150\Omega$ to $V_S/2$	0.06				%	typ	C	
Differential Phase	$G = +2, NTSC, V_O = 1.4V_P, R_L = 150\Omega$ to $V_S/2$	0.02				deg	typ	C	
DC PERFORMANCE⁽⁴⁾									
Open-Loop Voltage Gain (A_{OL})	$V_O = 2.5V, R_L = 100\Omega$ to $V_S/2$	63	56	54	52	dB	min	A	
Input Offset Voltage	$V_{CM} = 2.5V$	± 1.0	± 4.5	± 4.8	± 5.2	mV	max	A	
Average Offset Voltage Drift	$V_{CM} = 2.5V$			± 10	± 10	μ V/ $^{\circ}$ C	max	B	
Input Bias Current	$V_{CM} = 2.5V$	+5	± 11	± 12	± 13	μ A	max	A	
Average Bias Current Drift (magnitude)	$V_{CM} = 2.5V$			± 20	± 40	nA/ $^{\circ}$ C	max	B	
Input Offset Current	$V_{CM} = 2.5V$	± 0.3	± 1.0	± 1.4	± 1.6	μ A	max	A	
Average Offset Current Drift	$V_{CM} = 2.5V$			± 7	± 9	nA/ $^{\circ}$ C	max	B	
INPUT									
Least Positive Input Voltage ⁽⁵⁾		1.5	1.6	1.7	1.8	V	max	A	
Most Positive Input Voltage ⁽⁵⁾		3.5	3.4	3.3	3.2	V	min	A	
Common-Mode Rejection Ratio (CMRR)	$V_{CM} = 2.5V \pm 0.5V$	63	58	56	54	dB	min	A	
Input Impedance									
Differential Mode	$V_{CM} = 2.5V$	92 1.4				k Ω pF	typ	C	
Common-Mode	$V_{CM} = 2.5V$	2.2 1.5				M Ω pF	typ	C	

- (1) Test levels: **(A)** 100% tested at +25°C. Over temperature limits by characterization and simulation. **(B)** Limits set by characterization and simulation. **(C)** Typical value only for information.
- (2) Junction temperature = ambient for +25°C specifications.
- (3) Junction temperature = ambient at low temperature limits; junction temperature = ambient +15°C at high temperature limit for over temperature specifications.
- (4) Current is considered positive out of node. V_{CM} is the input common-mode voltage.
- (5) Tested < 3dB below minimum specified CMRR at \pm CMIR limits.

ELECTRICAL CHARACTERISTICS: $V_S = +5V$ (continued)**Boldface** limits are tested at **+25°C**.At $R_F = 402\Omega$, $R_L = 100\Omega$ to $V_S/2$, and $G = +2$ (see [Figure 37](#) for ac performance only), unless otherwise noted.

PARAMETER	TEST CONDITIONS	OPA2690ID, I-14D						TEST LEVELS ⁽¹⁾	
		TYP	MIN/MAX OVER TEMPERATURE				UNIT		MIN/MAX
			+25°C	+25°C ⁽²⁾	0°C to +70°C ⁽³⁾	-40°C to +85°C ⁽³⁾			
OUTPUT									
Most Positive Output Voltage	No Load	4	3.8	3.6	3.5	V	min	A	
	$R_L = 100\Omega$ to 2.5V	3.9	3.7	3.5	3.4	V	min	A	
Least Positive Output Voltage	No Load	1	1.2	1.4	1.5	V	max	A	
	$R_L = 100\Omega$ to 2.5V	1.1	1.3	1.5	1.7	V	max	A	
Current Output, Sourcing		+160	+120	+100	+80	mA	min	A	
Current Output, Sinking		-160	-120	-100	-80	mA	min	A	
Short-Circuit Current		± 250				mA	typ	C	
Closed-Loop Output Impedance	$G = +2$, $f = 100\text{kHz}$	0.04				Ω	typ	C	
DISABLE (SO-14 only)									
Power-Down Supply Current ($+V_S$)	Disabled LOW $V_{DIS} = 0V$, Both Channels	-200	-400	-480	-520	μA	max	A	
Off Isolation	$G = +2$, 5MHz	65				dB	typ	C	
Output Capacitance in Disable		4				pF	typ	C	
Turn-On Glitch	$G = +2$, $R_L = 150\Omega$, $V_{IN} = V_S/2$	± 50				mV	typ	C	
Turn-Off Glitch	$G = +2$, $R_L = 150\Omega$, $V_{IN} = V_S/2$	± 20				mV	typ	C	
Enable Voltage		3.3	3.5	3.6	3.7	V	min	A	
Disable Voltage		1.8	1.7	1.6	1.5	V	max	A	
Control Pin Input Bias Current (V_{DIS})	$V_{DIS} = 0V$, Each Channel	75	130	150	160	μA	typ	B	
POWER SUPPLY									
Specified Single-Supply Operating Voltage		5				V	typ	C	
Maximum Single-Supply Operating Voltage			12	12	12	V	max	B	
Maximum Quiescent Current (2 Channels)	$V_S = +5V$	9.8	10.88	11.44	12.1	mA	max	A	
Minimum Quiescent Current (2 Channels)	$V_S = +5V$	9.8	8.96	8.0	7.72	mA	min	A	
Power-Supply Rejection Ratio (+PSRR)	Input-Referred	72				dB	typ	C	
THERMAL CHARACTERISTICS									
Specification: D		-40 to +85				$^{\circ}\text{C}$	typ	C	
Thermal Resistance, θ_{JA}	Junction-to-Ambient								
D SO-8		125				$^{\circ}\text{C/W}$	typ	C	
D SO-14		150				$^{\circ}\text{C/W}$	typ	C	

TYPICAL CHARACTERISTICS: $V_S = \pm 5V$

At $T_A = +25^\circ C$, $G = +2$, $R_F = 402\Omega$, and $R_L = 100\Omega$ (see Figure 36 for ac performance only), unless otherwise noted.

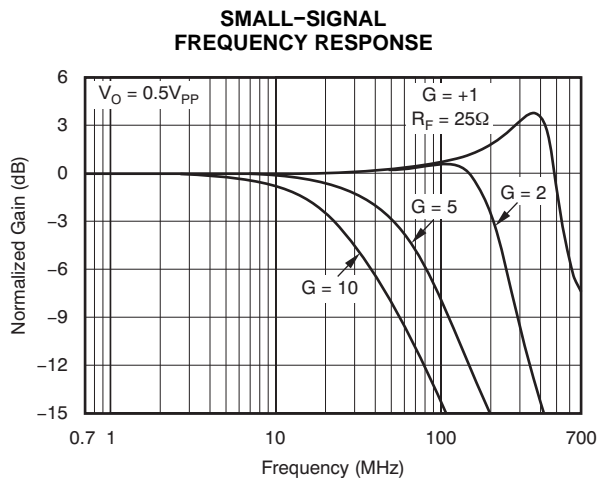

Figure 1.

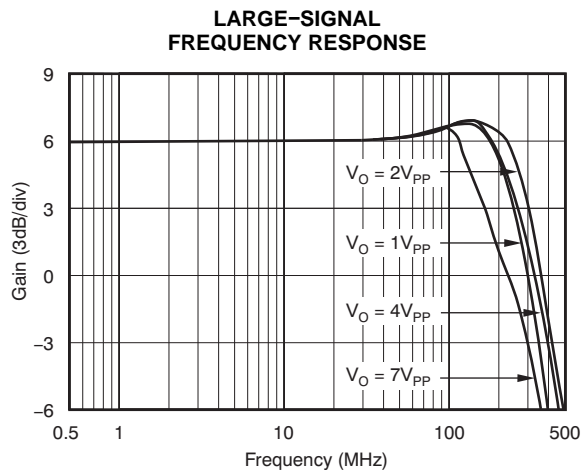

Figure 2.

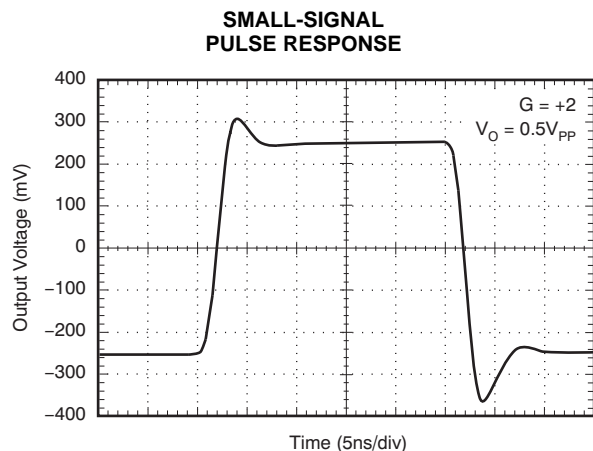

Figure 3.

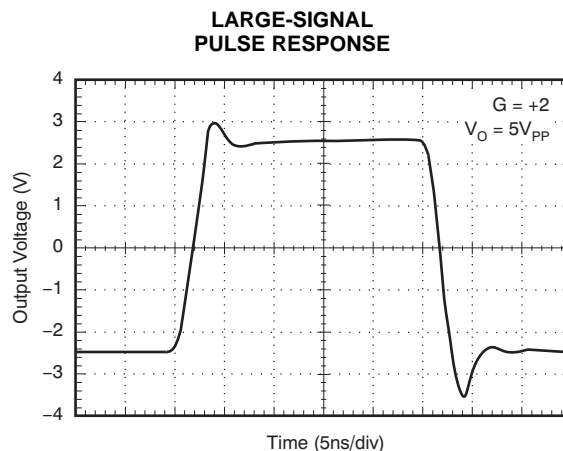

Figure 4.

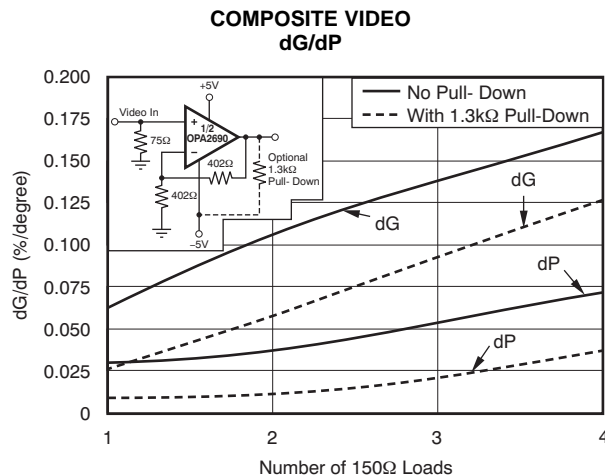

Figure 5.

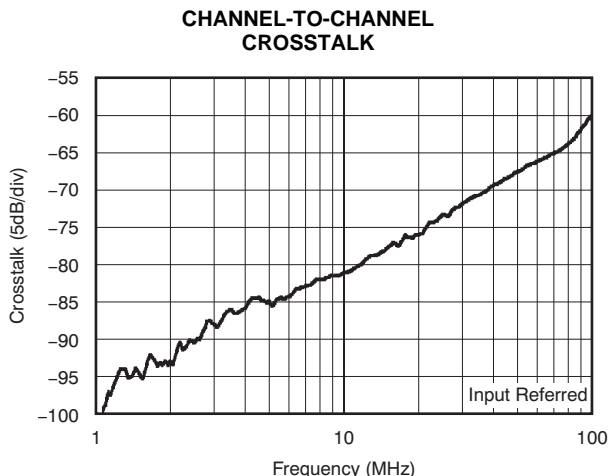

Figure 6.

TYPICAL CHARACTERISTICS: $V_S = \pm 5V$ (continued)

At $T_A = +25^\circ C$, $G = +2$, $R_F = 402\Omega$, and $R_L = 100\Omega$ (see Figure 36 for ac performance only), unless otherwise noted.

HARMONIC DISTORTION vs LOAD RESISTANCE

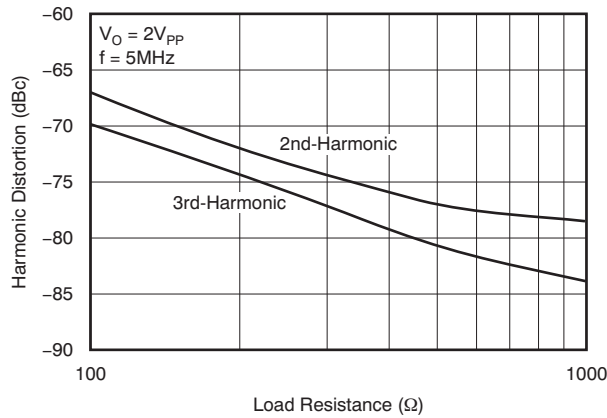

Figure 7.

5MHz HARMONIC DISTORTION vs SUPPLY VOLTAGE

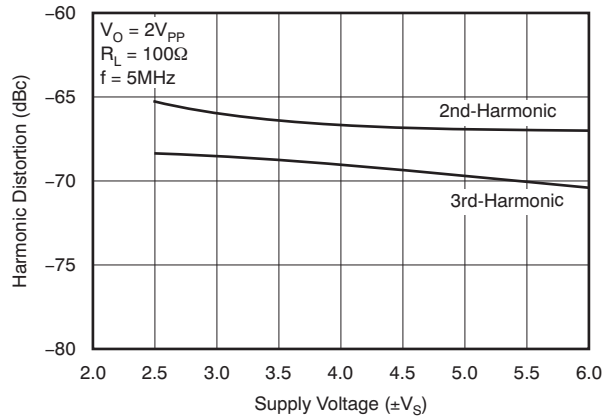

Figure 8.

HARMONIC DISTORTION vs FREQUENCY

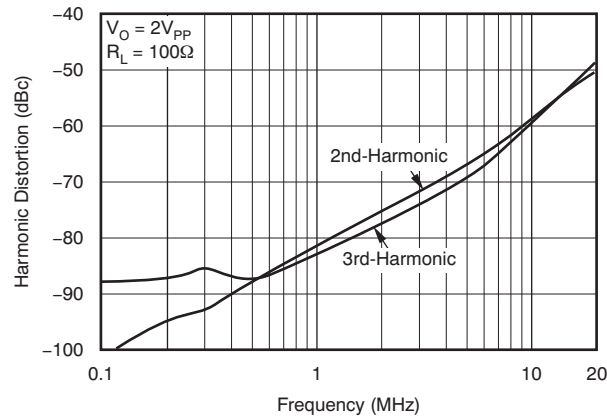

Figure 9.

HARMONIC DISTORTION vs OUTPUT VOLTAGE

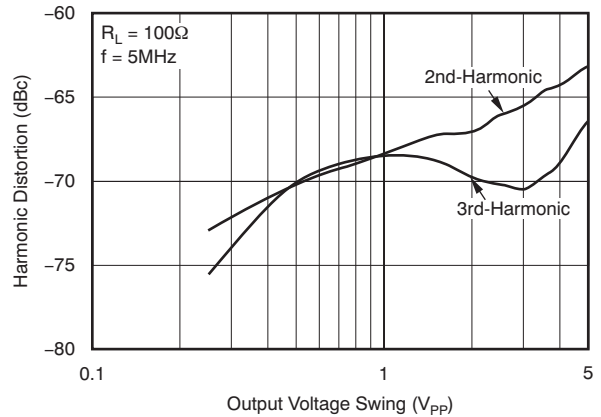

Figure 10.

HARMONIC DISTORTION vs NONINVERTING GAIN

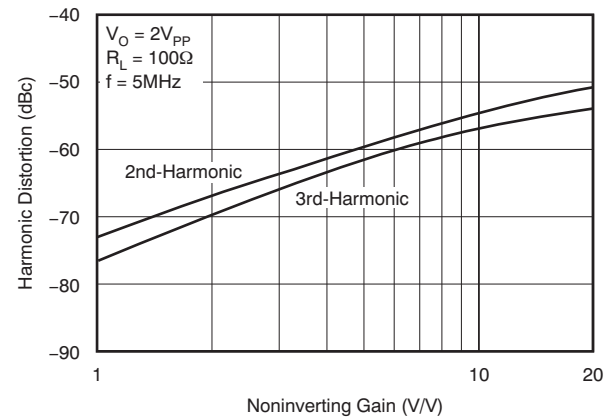

Figure 11.

HARMONIC DISTORTION vs INVERTING GAIN

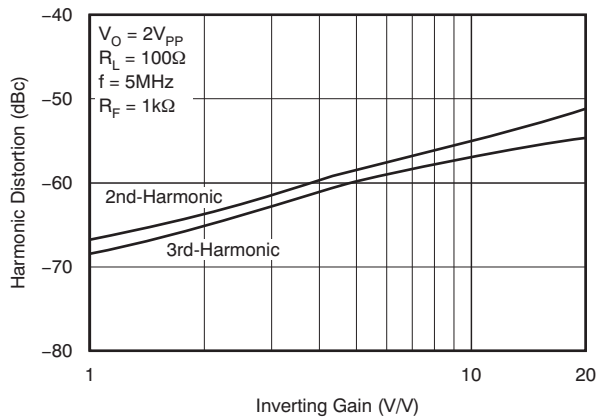

Figure 12.

TYPICAL CHARACTERISTICS: $V_S = \pm 5V$ (continued)

At $T_A = +25^\circ C$, $G = +2$, $R_F = 402\Omega$, and $R_L = 100\Omega$ (see Figure 36 for ac performance only), unless otherwise noted.

INPUT VOLTAGE AND CURRENT NOISE DENSITY

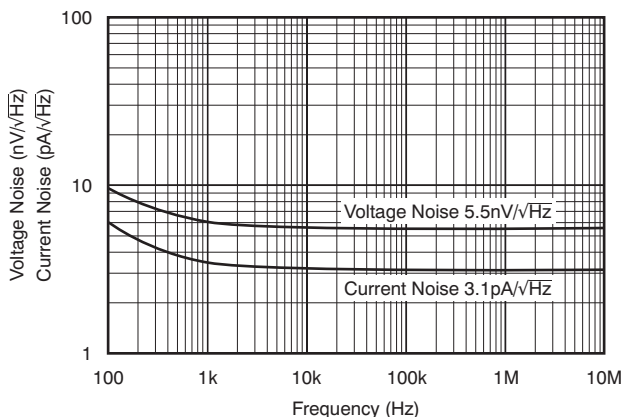

Figure 13.

TWO-TONE, 3RD-ORDER INTERMODULATION SPURIOUS

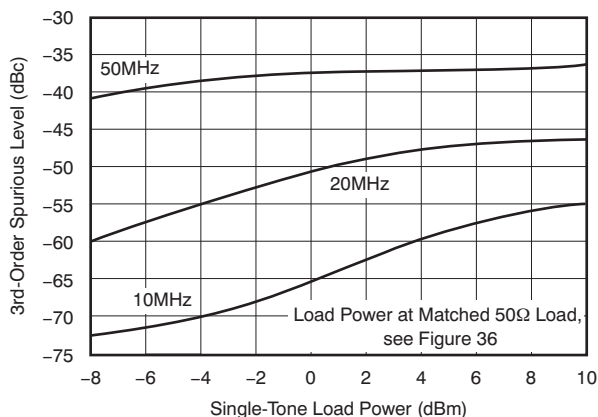

Figure 14.

RECOMMENDED R_S vs CAPACITIVE LOAD

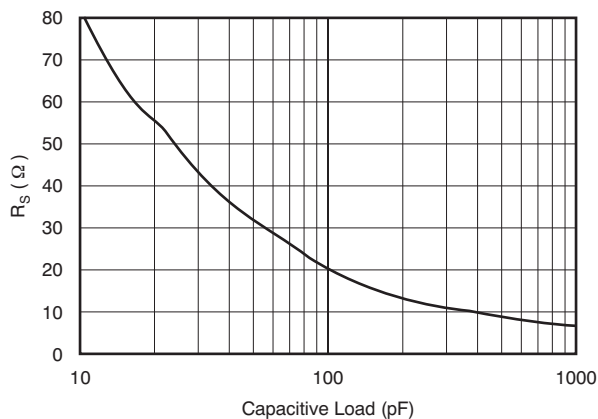

Figure 15.

FREQUENCY RESPONSE vs CAPACITIVE LOAD

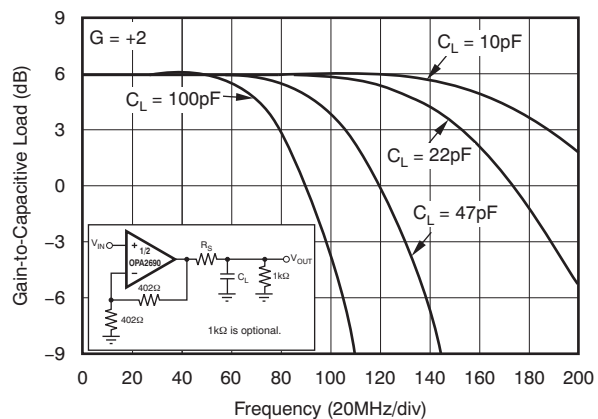

Figure 16.

LARGE-SIGNAL ENABLE/DISABLE RESPONSE

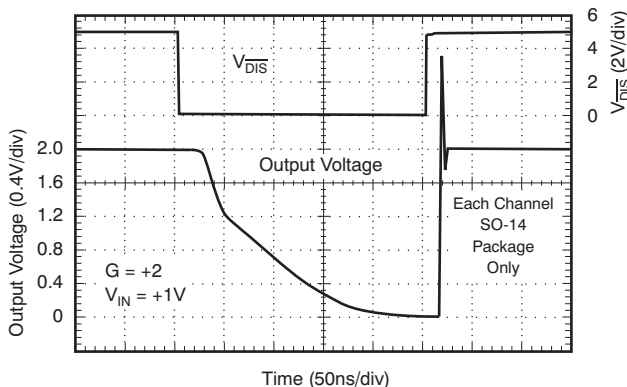

Figure 17.

DISABLE FEEDTHROUGH vs FREQUENCY

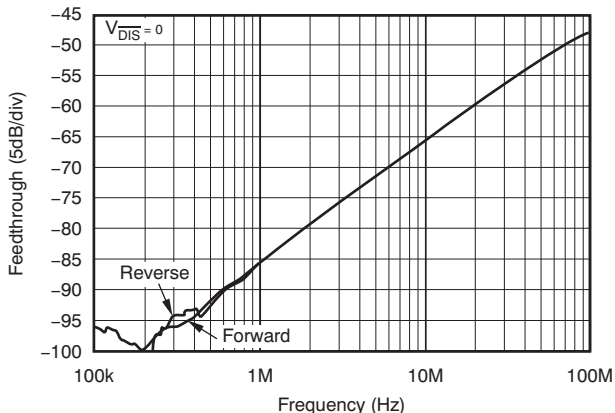

Figure 18.

TYPICAL CHARACTERISTICS: $V_S = \pm 5V$ (continued)

At $T_A = +25^\circ C$, $G = +2$, $R_F = 402\Omega$, and $R_L = 100\Omega$ (see Figure 36 for ac performance only), unless otherwise noted.

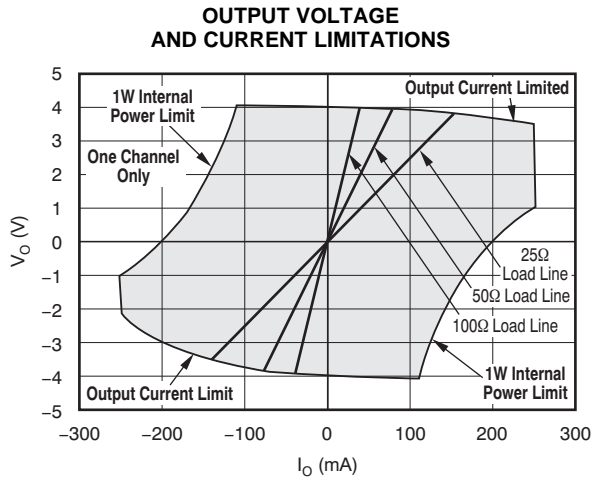

Figure 19.

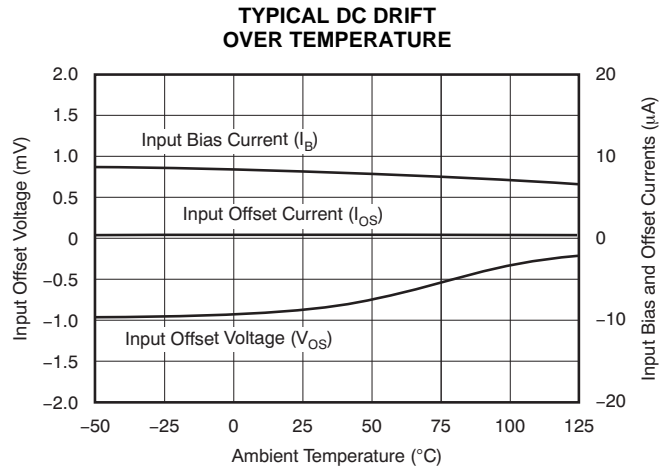

Figure 20.

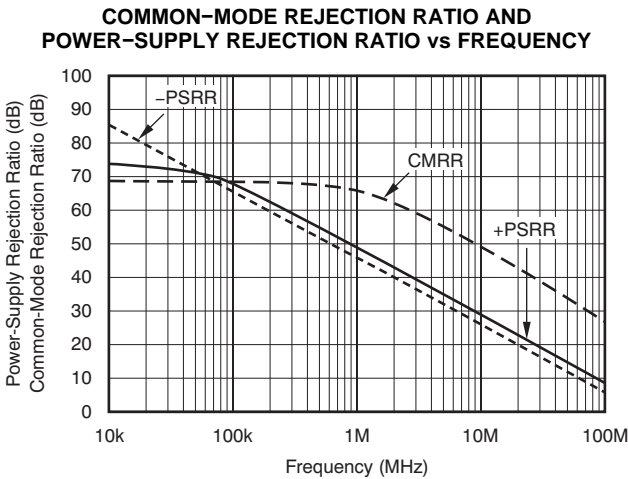

Figure 21.

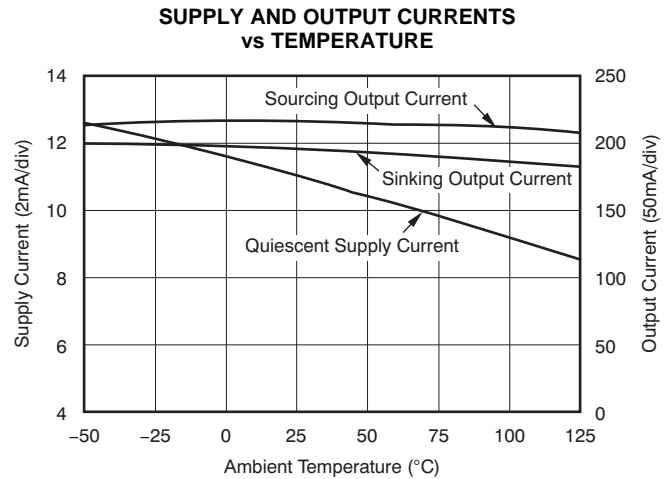

Figure 22.

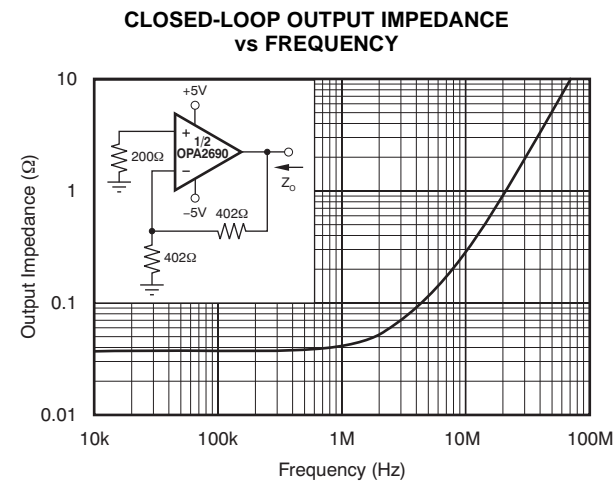

Figure 23.

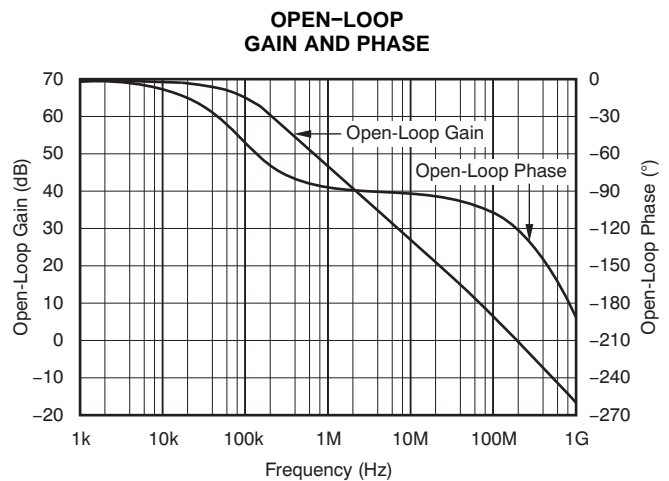

Figure 24.

TYPICAL CHARACTERISTICS: $V_S = \pm 5V$ (continued)

At $T_A = +25^\circ C$, $G = +2$, $R_F = 402\Omega$, and $R_L = 100\Omega$ (see Figure 36 for ac performance only), unless otherwise noted.

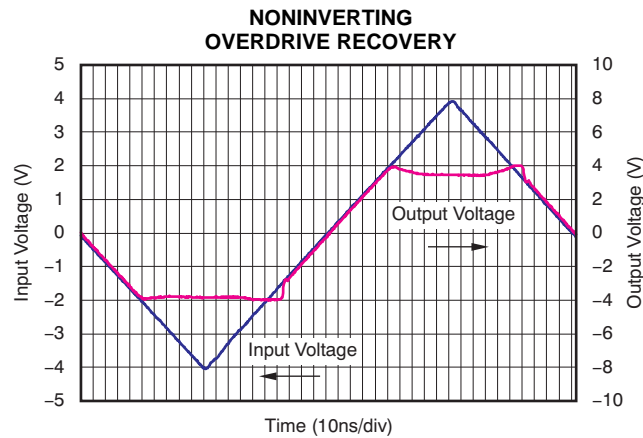

Figure 25.

TYPICAL CHARACTERISTICS: +5V

At $T_A = +25^\circ\text{C}$, $G = +2$, $R_F = 402\Omega$, and $R_L = 100\Omega$ (see Figure 37 for ac performance only), unless otherwise noted.

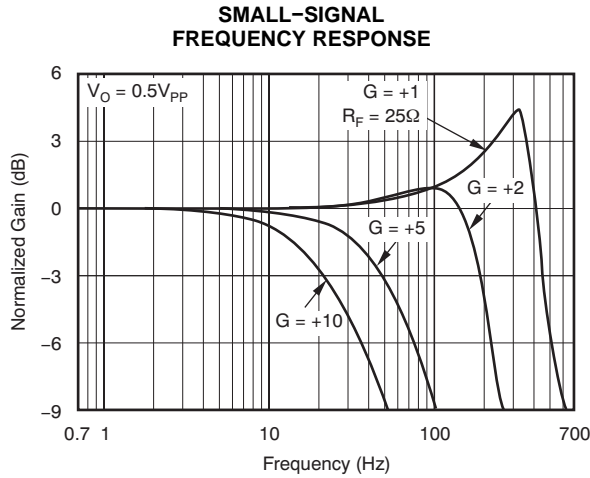

Figure 26.

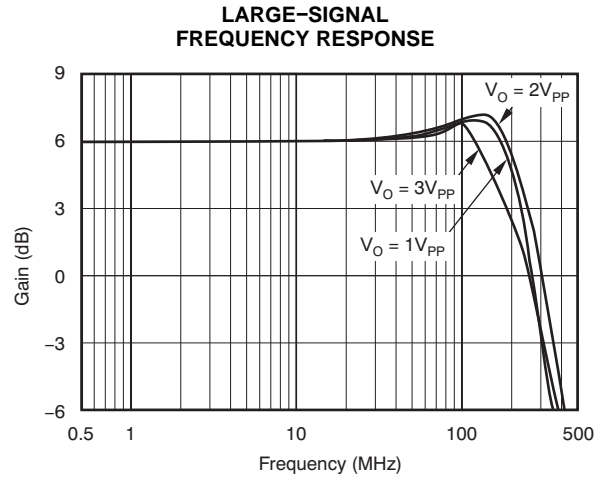

Figure 27.

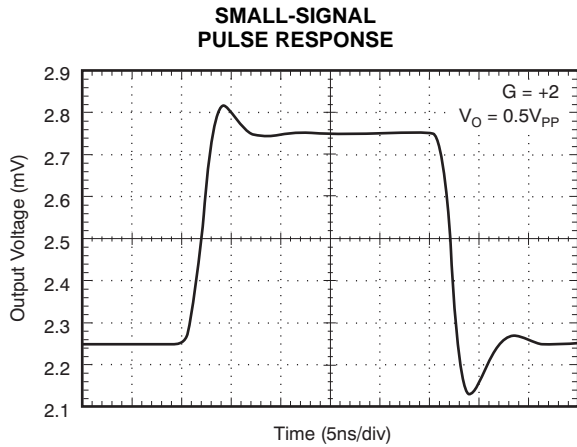

Figure 28.

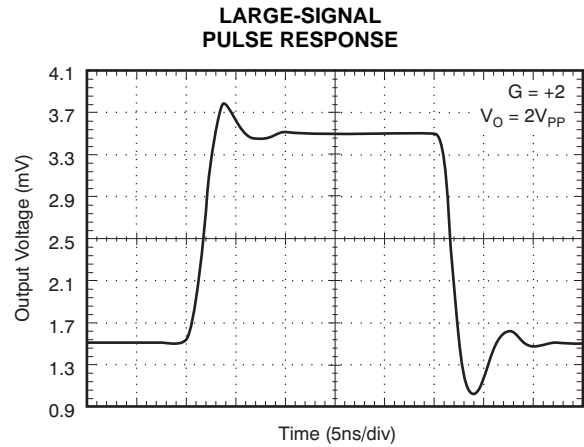

Figure 29.

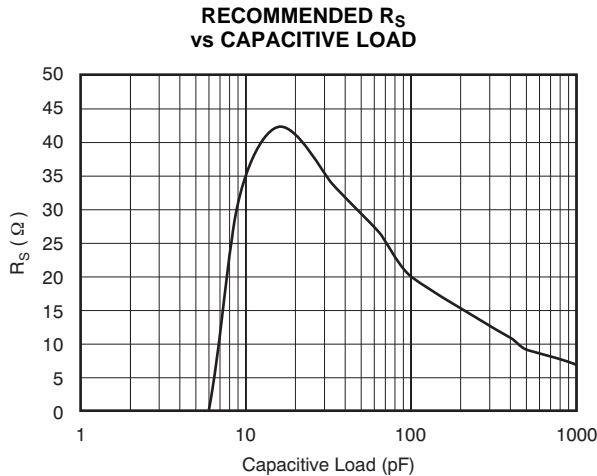

Figure 30.

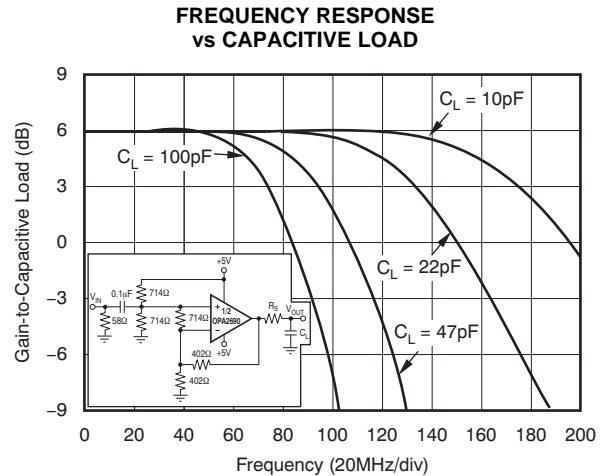

Figure 31.

TYPICAL CHARACTERISTICS: +5V (continued)

At $T_A = +25^\circ\text{C}$, $G = +2$, $R_F = 402\Omega$, and $R_L = 100\Omega$ (see Figure 37 for ac performance only), unless otherwise noted.

HARMONIC DISTORTION vs LOAD RESISTANCE

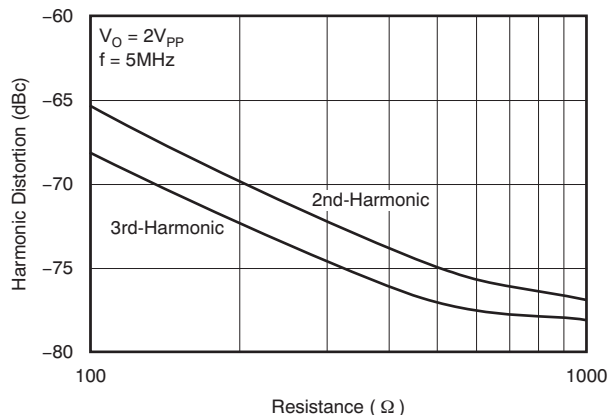

Figure 32.

HARMONIC DISTORTION vs FREQUENCY

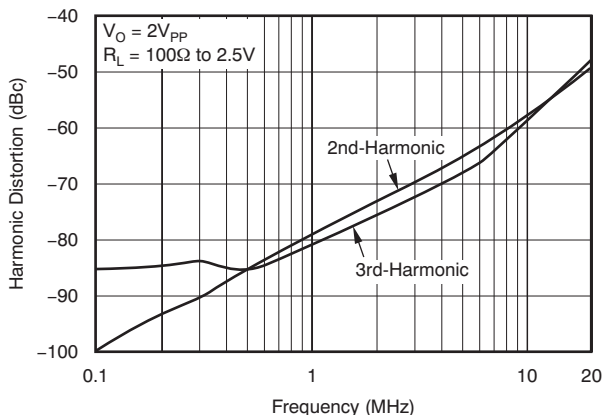

Figure 33.

HARMONIC DISTORTION vs OUTPUT VOLTAGE

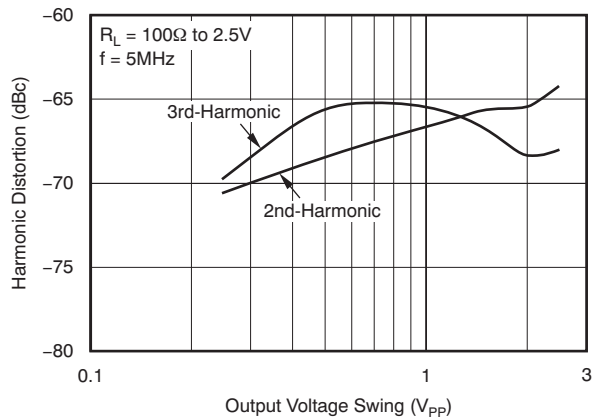

Figure 34.

TWO-TONE, 3RD-ORDER INTERMODULATION SPURIOUS

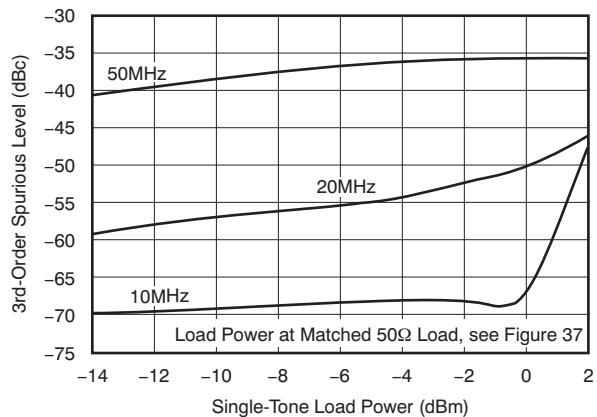

Figure 35.

Again, an additional resistor (50Ω in this case) is included directly in series with the noninverting input. This minimum recommended value provides part of the dc source resistance matching for the noninverting input bias current. It is also used to form a simple parasitic pole to roll off the frequency response at very high frequencies (> 500MHz) using the input parasitic capacitance. The gain resistor (R_G) is ac-coupled, giving the circuit a dc gain of +1, which puts the input dc bias voltage (2.5V) on the output as well. The output voltage can swing to within 1V of either supply pin while delivering > 100mA output current. A demanding 100Ω load to a midpoint bias is used in this characterization circuit. The new output stage circuit used in the OPA2690 can deliver large bipolar output currents into this midpoint load with minimal crossover distortion, as shown in the +5V supply harmonic distortion plots.

SINGLE-SUPPLY ADC INTERFACE

Most modern, high-performance ADCs (such as the TI ADS8xx and ADS9xx series) operate on a single +5V (or lower) power supply. It has been a considerable challenge for single-supply op amps to deliver a low distortion input signal at the ADC input for signal frequencies exceeding 5MHz. The high slew rate, exceptional output swing, and high linearity of the OPA2690 make it an ideal single-supply ADC driver. The circuit on the front page shows one possible interface particularly suited to differential I/O, ac-coupled requirements. Figure 39 shows the test circuit of Figure 37 modified for a capacitive (ADC) load and with an optional output pull-down resistor (R_B). This circuit would be suitable to dual-channel ADC driving with a single-ended I/O.

The OPA2690 in the circuit of Figure 39 provides > 200MHz bandwidth for a 2V_{PP} output swing. Minimal 3rd-harmonic distortion or two-tone, 3rd-order intermodulation distortion will be observed due to the very low crossover distortion in the OPA2690 output stage. The limit of output Spurious-Free Dynamic Range (SFDR) will be set by the 2nd-harmonic distortion. Without R_B , the circuit of Figure 39 measured at 10MHz shows an SFDR of 57dBc. This can be improved by pulling additional dc bias current (I_B) out of the output stage through the optional R_B resistor to ground (the output midpoint is at 2.5V for Figure 39). Adjusting I_B gives the improvement in SFDR shown in Figure 38. SFDR improvement is achieved for I_B values up to 5mA, with worse performance for higher values. Using the dual OPA2690 in an I/Q receiver channel will give matched ac performance through high frequencies.

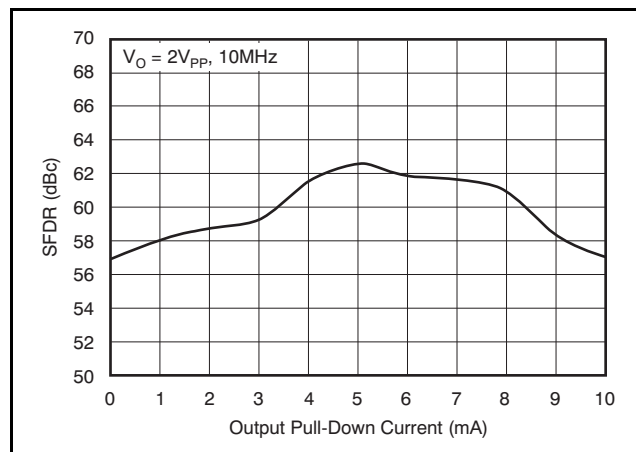

Figure 38. SFDR vs I_B

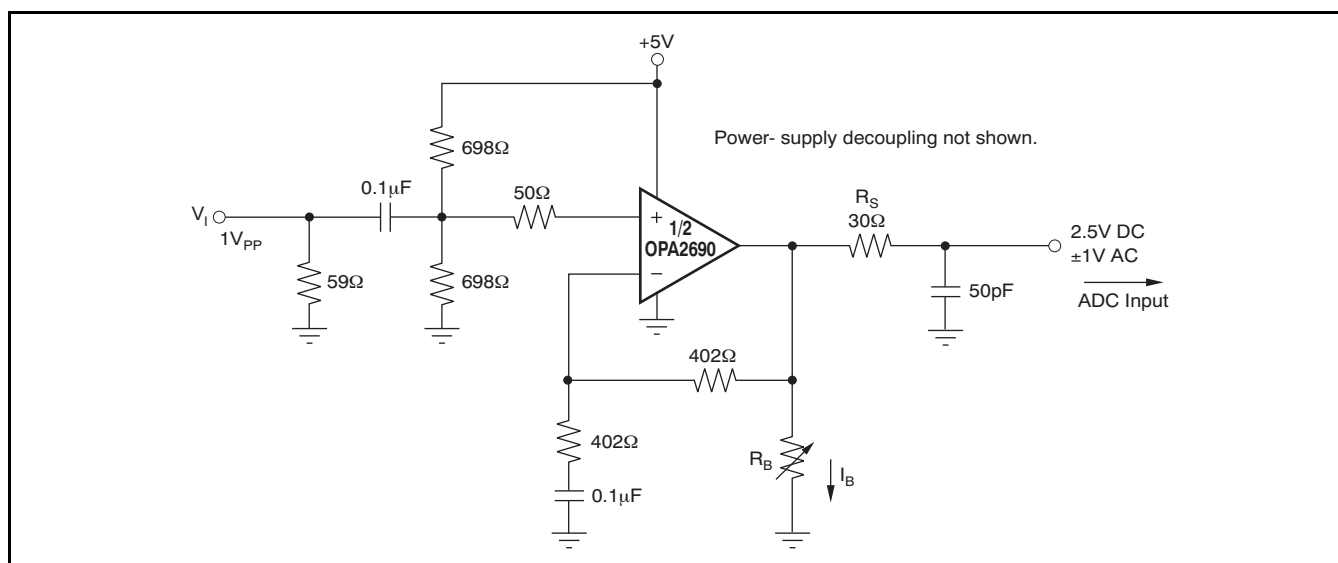

Figure 39. SFDR versus I_B Test Circuit

HIGH-PERFORMANCE DAC TRANSIMPEDANCE AMPLIFIER

High-frequency, direct digital synthesis (DDS) digital-to-analog converters (DACs) require a low distortion output amplifier to retain their SFDR performance into real-world loads. Figure 40 shows a single-ended output drive implementation. The diagram shows the signal output current(s) connected into the virtual ground summing junction(s) of the OPA2690, which is set up as a transimpedance stage or *I-V converter*. If the DAC requires that its outputs terminate to a compliance voltage other than ground for operation, the appropriate voltage level may be applied to the noninverting input of the OPA2690. The dc gain for this circuit is equal to R_F . At high frequencies, the DAC output capacitance (C_D in Figure 40) will produce a zero in the noise gain for the OPA2690 that may cause peaking in the closed-loop frequency response. C_F is added across R_F to compensate for this noise gain peaking. To achieve a flat transimpedance frequency response, the pole in each feedback network should be set to:

$$\frac{1}{2\pi R_F C_F} = \sqrt{\frac{GBP}{4\pi R_F C_D}} \tag{1}$$

which will give a cutoff frequency, f_{-3dB} , of approximately:

$$f_{-3dB} = \sqrt{\frac{GBP}{2\pi R_F C_D}} \tag{2}$$

Where GBP = gain bandwidth product (Hz) for the OPA2690.

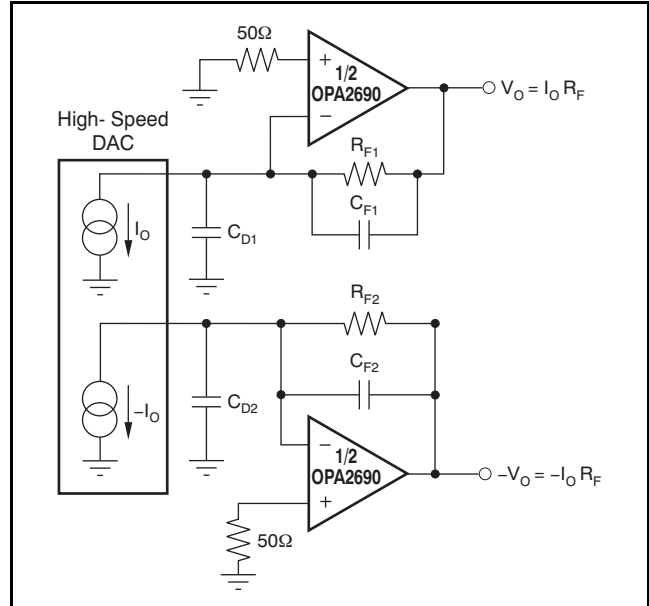

Figure 40. DAC Transimpedance Amplifier

WIDEBAND VIDEO MULTIPLEXING

One common application for video speed amplifiers that include a disable pin is to wire multiple amplifier outputs together, then select which one of several possible video inputs to source onto a single line. This simple wired-OR video multiplexer can be easily implemented using the OP2690I-14D (SO-14 package only), as shown in Figure 6.

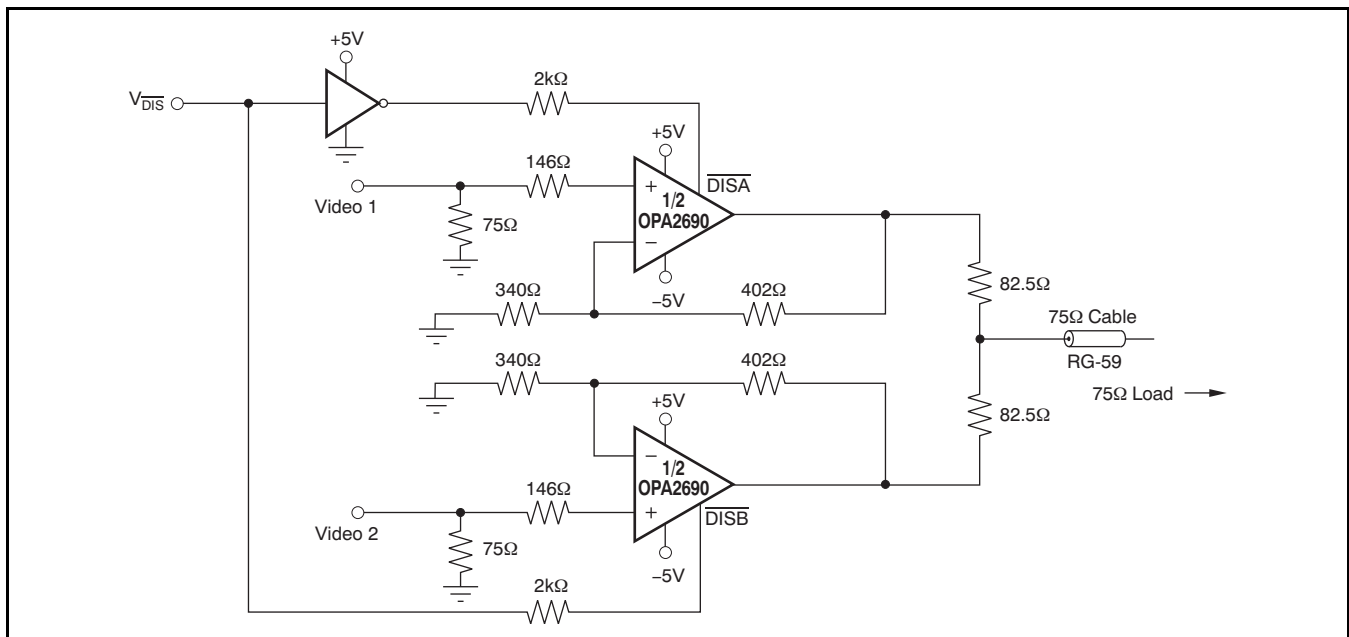

Figure 41. Two-Channel Video Multiplexer (SO-14 package only)

Typically, channel switching is performed either on sync or retrace time in the video signal. The two inputs are approximately equal at this time. The make-before-break disable characteristic of the OPA2690 ensures that there is always one amplifier controlling the line when using a wired-OR circuit like that shown in Figure 41. As both inputs may be on for a short period during the transition between channels, the outputs are combined through the output impedance matching resistors (82.5Ω in this case). When one channel is disabled, its feedback network forms part of the output impedance and slightly attenuates the signal in getting out onto the cable. The gain and output matching resistor have been slightly increased to get a signal gain of +1 at the matched load and provide a 75Ω output impedance to the cable. The video multiplexer connection (see Figure 41) also ensures that the maximum differential voltage across the inputs of the unselected channel does not exceed the rated ±1.2V maximum for standard video signal levels.

See the *Disable Operation* section for the turn-on and turn-off switching glitches using a 0V input for a single channel is typically less than ±50mV. Where two outputs are switched (see Figure 41), the output line is always under the control of one amplifier or the other due to the make-before-break disable timing. In this case, the switching glitches for two 0V inputs drops to < 20mV.

HIGH-SPEED DELAY CIRCUIT

The OPA2690 makes an ideal amplifier for a variety of active filter designs. Shown in Figure 42 is a circuit that uses the two amplifiers within the dual OPA2690 to design a two-stage analog delay circuit. For simplicity, the circuit uses a dual-supply (±5V) operation, but it can also be modified to operate on a signal supply. The input to the first filter stage is driven by the OPA692 wideband buffer amplifier to isolate the signal input from the filter network.

Each of the two filter stages is a 1st-order filter with a voltage gain of +1. The delay time through one filter is given by Equation 3:

$$t_{GR0} = 2RC \tag{3}$$

For a more accurate analysis of the circuit, consider the group delay for the amplifiers. For example, in the case of the OPA2690, the group delay in the bandwidth from 1MHz to 100MHz is approximately 1.0ns. To account for this, modify the transfer function, which now comes out to be:

$$t_{GR} = 2(2RC + t_D) \tag{4}$$

Where $t_D = (1/360) \times (d\phi/df) =$ delay of the op amp itself.

The values of resistors R_F and R_G should be equal and low to avoid parasitic effects. If the all-pass filter is designed for very low delay times, include parasitic board capacitances to calculate the correct delay time. Simulating this application using the PSPICE model of the OPA2690 will allow this design to be tuned to the desired performance.

DIFFERENTIAL RECEIVER/DRIVER

A very versatile application for a dual operational amplifier is the differential amplifier configuration detailed in Figure 43. With both amplifiers of the OPA2690 connected for noninverting operation, the circuit provides a high input impedance whereas the gain can easily be set by just one resistor, R_G . When operated in low gains, the output swing may be limited as a result of the common-mode input swing limits of the amplifier itself. An interesting modification of this circuit is to place a capacitor in series with the R_G . Now the dc gain for each side is reduced to +1, whereas the ac gain still follows the standard transfer function of $G = 1 + 2R_F/R_G$. This might be advantageous for applications processing only a frequency band that excludes dc or very low frequencies. An input dc voltage resulting from input bias currents is not amplified by the ac gain and can be kept low. This circuit can be used as a differential line receiver, driver, or as an interface to a differential input ADC.

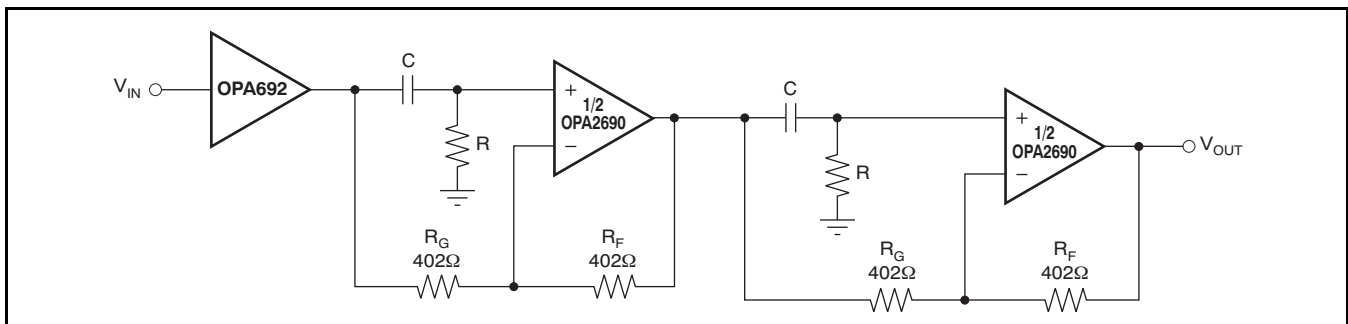

Figure 42. Two-Stage, All-Pass Network

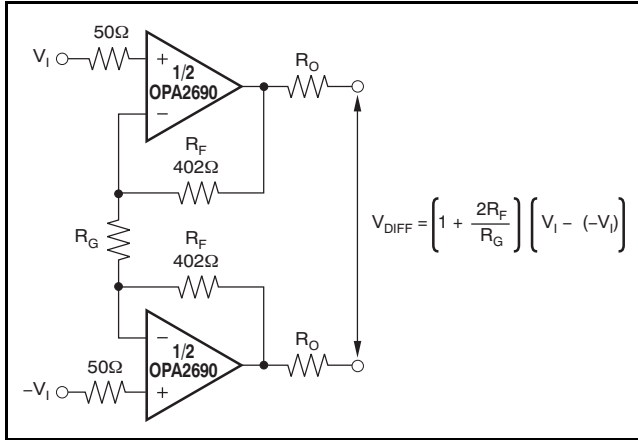

Figure 43. High-Speed Differential Receiver

SINGLE-SUPPLY MFB DIFFERENTIAL ACTIVE FILTER: 10MHz BUTTERWORTH CONFIGURATION

The active filter circuit shown in Figure 44 can be easily implemented using the OPA2690. In this configuration, each amplifier of the OPA2690 operates as an integrator. For this reason, this type of application is also called infinite gain filter implementation. A Butterworth filter can be implemented using the following component ratios:

$$f_o = \frac{1}{2 \times \pi \times R \times C} \text{ (cutoff frequency)}$$

$$R_1 = R_2 = 0.65 \times R$$

$$R_3 = 0.375 \times R$$

$$C_1 = C$$

$$C_2 = 2 \times C$$

(5)

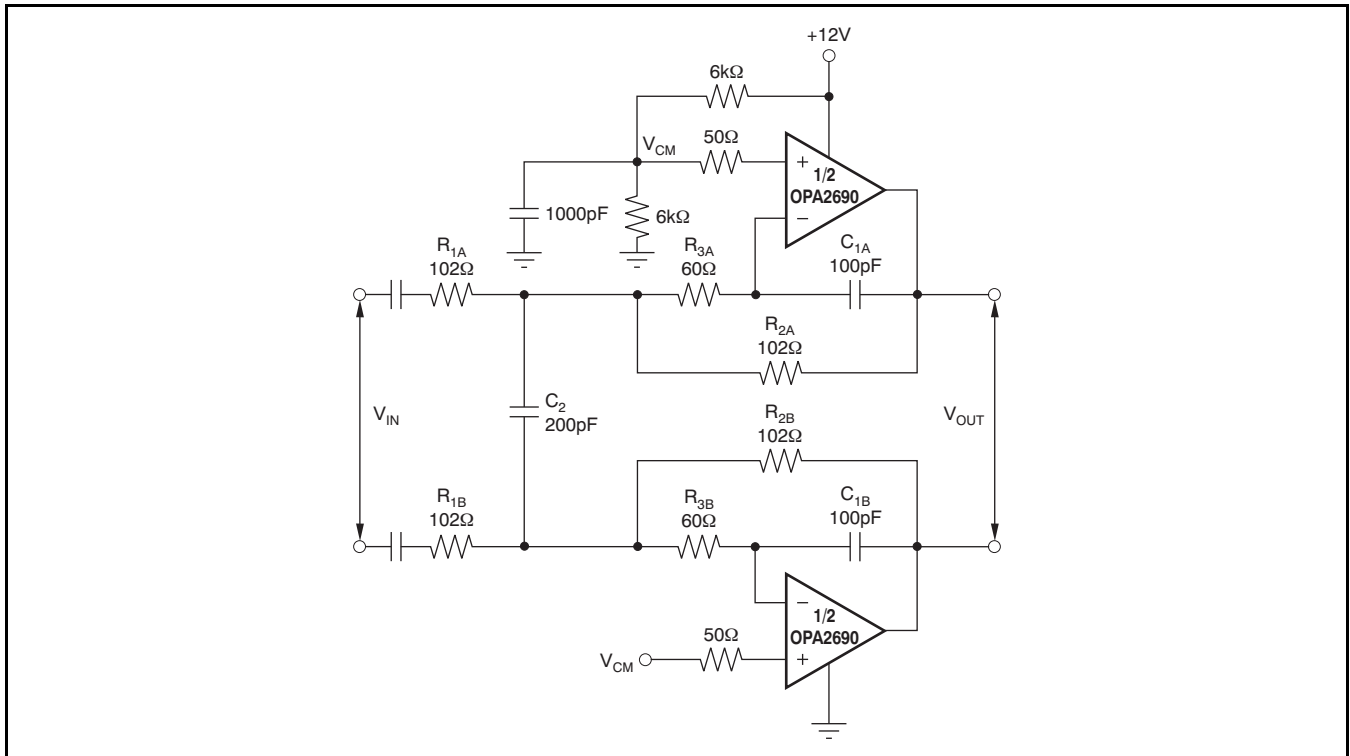

Figure 44. Single-Supply, MFB Active Filter, 10MHz LP Butterworth

The frequency response for a 10MHz Butterworth filter is shown in Figure 45. One advantage for using this type of filter is the independent setting of ω_o and Q. Q can be easily adjusted by changing the $R_{3A, B}$ resistors without affecting ω_o .

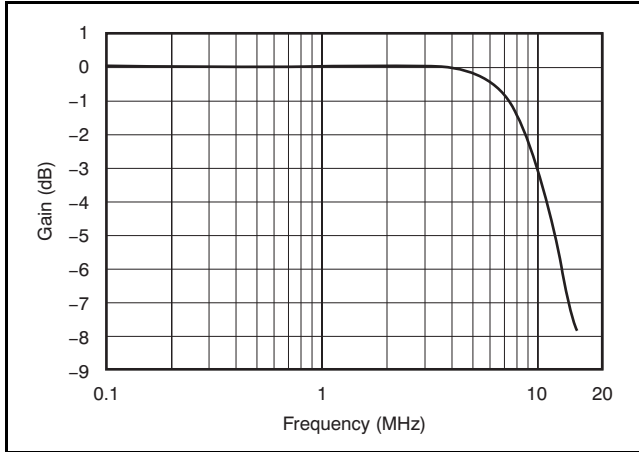

Figure 45. Multiple Feedback Filter Frequency Response

SINGLE-SUPPLY DIFFERENTIAL ADC DRIVER

The circuit shown on the front page is ideal for driving high-frequency ADCs. As shown in the plot on the front page (Harmonic Distortion vs Frequency for the

Single-Supply Differential ADC Driver), the 2nd-harmonic reacts as expected and drops to a -95dBc at 1MHz and -87dBc at 5MHz—a significant improvement in going to differential from single-ended.

The circuit shown on the front page has a 195MHz, -3dB bandwidth that can be easily bandlimited by using a capacitor in parallel with the feedback resistors. Refer to Figure 46 for more details. The -3dB frequency is given by Equation 6.

$$f_{-3dB} = \frac{1}{2\pi R_F C_F} \tag{6}$$

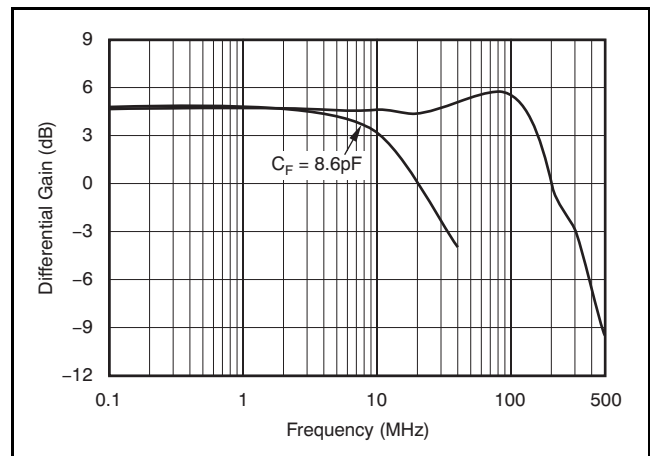

Figure 46. Single-Supply Differential ADC Driver

For example, $C_F = 8.6\text{pF}$ in parallel with $R_F = 402\Omega$ will control the -3dB frequency to 18MHz.

DESIGN-IN TOOLS

DEMONSTRATION FIXTURES

Two printed circuit boards (PCBs) are available to assist in the initial evaluation of circuit performance using the OPA2690 in its two package options. Both of these are offered free of charge as unpopulated PCBs, delivered with a user's guide. The summary information for these fixtures is shown in [Table 1](#).

Table 1. Demonstration Fixtures by Package

PRODUCT	PACKAGE	ORDERING NUMBER	LITERATURE NUMBER
OPA2690ID	SO-8	DEM-OPA-SO-2A	SBOU003
OPA2690I-14D	SO-14	DEM-OPA-SO-2D	SBOU002

The demonstration fixtures can be requested at the Texas Instruments web site (www.ti.com) through the [OPA2690 product folder](#).

MACROMODELS

Computer simulation of circuit performance using SPICE is often useful when analyzing the performance of analog circuits and systems. This is particularly true for video and RF amplifier circuits where parasitic capacitance and inductance can have a major effect on circuit performance. A SPICE model for the OPA2690 (use two OPA690 SPICE models) is available through the [OPA2690 product folder](#) under *Simulation Models*. These models do a good job of predicting small-signal ac and transient performance under a wide variety of operating conditions. They do not do as well in predicting the harmonic distortion or dG/dP characteristics. These models do not attempt to distinguish between the package types in their small-signal ac performance.

OPERATING SUGGESTIONS

OPTIMIZING RESISTOR VALUES

As the the OPA2690 is a unity-gain stable, voltage-feedback op amp, a wide range of resistor values may be used for the feedback and gain setting resistors. The primary limits on these values are set by dynamic range (noise and distortion) and parasitic capacitance considerations. For a noninverting unity-gain follower application, the feedback connection should be made with a 25 Ω resistor, not a direct short. This will isolate the inverting input capacitance from the output pin and improve the frequency response flatness. Usually, the feedback resistor value should be between 200 Ω and 1.5k Ω . Below 200 Ω , the feedback network will present additional output loading which can degrade the harmonic distortion performance of the OPA2690. Above 1.5k Ω , the typical parasitic capacitance (approximately 0.2pF) across the feedback resistor can cause unintentional band-limiting in the amplifier response.

A good rule of thumb is to target the parallel combination of R_F and R_G (see [Figure 36](#)) to be less than approximately 300 Ω . The combined impedance $R_F \parallel R_G$ interacts with the inverting input capacitance, placing an additional pole in the feedback network and thus, a zero in the forward response. Assuming a 2pF total parasitic on the inverting node, holding $R_F \parallel R_G < 300\Omega$ will keep this pole above 250MHz. By itself, this constraint implies that feedback resistor R_F can increase to several k Ω at high gains. This is acceptable as long as the pole formed by R_F and any parasitic capacitance appearing in parallel is kept out of the frequency range of interest.

BANDWIDTH vs GAIN: NONINVERTING OPERATION

Voltage-feedback op amps exhibit decreasing closed-loop bandwidth as the signal gain is increased. In theory, this relationship is described by the Gain Bandwidth Product (GBP) shown in the Electrical Characteristics. Ideally, dividing GBP by the noninverting signal gain (also called the Noise Gain, or NG) will predict the closed-loop bandwidth. In practice, this only holds true when the phase margin approaches 90°, as it does in high gain configurations. At low gains (increased feedback factors), most amplifiers will exhibit a more complex response with lower phase margin. The OPA2690 is compensated to give a slightly peaked response in a noninverting gain of 2 (see [Figure 36](#)). This results in a typical gain of +2 bandwidth of 220MHz, far exceeding that predicted by dividing the 300MHz GBP by 2. Increasing the gain will cause the phase margin to approach 90° and the bandwidth to more closely approach the predicted value of (GBP/NG). At a gain of +10, the 30MHz bandwidth shown in the Electrical Characteristics agrees with that predicted using the simple formula and the typical GBP of 300MHz.

The frequency response in a gain of +2 may be modified to achieve exceptional flatness simply by increasing the noise gain to 2.5. One way to do this, without affecting the +2 signal gain, is to add an 804 Ω resistor across the two inputs in the circuit of [Figure 36](#). A similar technique may be used to reduce peaking in unity-gain (voltage follower) applications. For example, by using a 402 Ω feedback resistor along with a 402 Ω resistor across the two op amp inputs, the voltage follower response will be similar to the gain of +2 response of [Figure 37](#). Reducing the value of the resistor across the op amp inputs will further limit the frequency response due to increased noise gain.

The OPA2690 exhibits minimal bandwidth reduction going to single-supply (+5V) operation as compared with $\pm 5V$. This is because the internal bias control circuitry retains nearly constant quiescent current as the total supply voltage between the supply pins is changed.

INVERTING AMPLIFIER OPERATION

Since the OPA2690 is a general-purpose, wideband voltage-feedback op amp, all of the familiar op amp application circuits are available to the designer. Inverting operation is one of the more common requirements and offers several performance benefits. Figure 47 shows a typical inverting configuration where the I/O impedances and signal gain from Figure 36 are retained in an inverting circuit configuration.

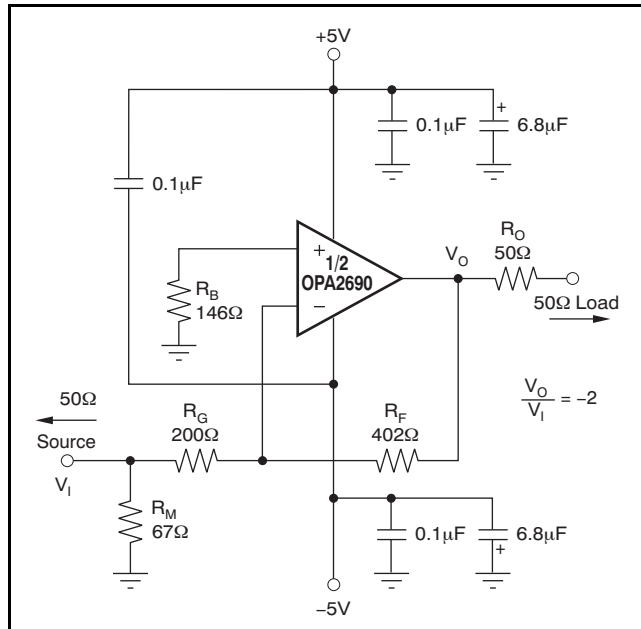

Figure 47. Gain of -2 Example Circuit

In the inverting configuration, three key design considerations must be noted. The first is that the gain resistor (R_G) becomes part of the signal channel input impedance. If input impedance matching is desired (which is beneficial whenever the signal is coupled through a cable, twisted-pair, long PCB trace, or other transmission line conductor), R_G may be set equal to the required termination value and R_F adjusted to give the desired gain. This is the simplest approach and results in optimum bandwidth and noise performance. However, at low inverting gains, the resultant feedback resistor value can present a significant load to the amplifier output. For an inverting gain of -2 , setting R_G to 50Ω for input matching eliminates the need for R_M but requires a

100Ω feedback resistor. This has the interesting advantage that the noise gain becomes equal to 2 for a 50Ω source impedance—the same as the noninverting circuits considered in the previous section. The amplifier output, however, will now see the 100Ω feedback resistor in parallel with the external load. In general, the feedback resistor should be limited to the 200Ω to $1.5k\Omega$ range. In this case, it is preferable to increase both the R_F and R_G values, as shown in Figure 47, and then achieve the input matching impedance with a third resistor (R_M) to ground. The total input impedance becomes the parallel combination of R_G and R_M .

The second major consideration, touched on in the previous paragraph, is that the signal source impedance becomes part of the noise gain equation and influences the bandwidth. For the example in Figure 47, the R_M value combines in parallel with the external 50Ω source impedance, yielding an effective driving impedance of $50\Omega \parallel 67\Omega = 28.6\Omega$. This impedance is added in series with R_G for calculating the noise gain (NG). The resultant NG is 2.8 for Figure 47, as opposed to only 2 if R_M could be eliminated as discussed above. The bandwidth will therefore be slightly lower for the gain of -2 circuit of Figure 47 than for the gain of $+2$ circuit of Figure 36.

The third important consideration in inverting amplifier design is setting the bias current cancellation resistor on the noninverting input (R_B). If this resistor is set equal to the total dc resistance looking out of the inverting node, the output dc error, due to the input bias currents, will be reduced to (Input Offset Current) $\times R_F$. If the 50Ω source impedance is dc-coupled in Figure 47, the total resistance to ground on the inverting input will be 228Ω . Combining this in parallel with the feedback resistor gives the $R_B = 146\Omega$ used in this example. To reduce the additional high-frequency noise introduced by this resistor, it is sometimes bypassed with a capacitor. As long as $R_B < 350\Omega$, the capacitor is not required because the total noise contribution of all other terms will be less than that of the op amp input noise voltage. As a minimum, the OPA2690 requires an R_B value of 50Ω to damp out parasitic-induced peaking—a direct short to ground on the noninverting input runs the risk of a very high-frequency instability in the input stage.

OUTPUT CURRENT AND VOLTAGE

The OPA2690 provides output voltage and current capabilities in a low-cost monolithic op amp. Under no-load conditions at +25°C, the output voltage typically swings closer than 1V to either supply rail; the specified swing limit is within 1.2V of either rail. Into a 15Ω load (the minimum tested load), it will deliver more than ±160mA.

The specifications described previously, though familiar in the industry, consider voltage and current limits separately. In many applications, it is the voltage × current, or V-I product, that is more relevant to circuit operation. Refer to [Figure 19](#), the *Output Voltage and Current Limitations* plot in the Typical Characteristics. The X- and Y-axes of this graph show the zero-voltage output current limit and the zero-current output voltage limit, respectively. The four quadrants give a more detailed view of the OPA2690 output drive capabilities, noting that the graph is bounded by a *Safe Operating Area* of 1W maximum internal power dissipation for each channel separately. Superimposing resistor load lines onto the plot shows that the OPA2690 can drive ±2.5V into 25Ω or ±3.5V into 50Ω without exceeding the output capabilities or the 1W dissipation limit. A 100Ω load line (the standard test circuit load) shows the full ±3.9V output swing capability (see the Electrical Characteristics).

The minimum specified output voltage and current specifications over temperature are set by worst-case simulations at the cold temperature extreme. Only at cold startup will the output current and voltage decrease to the numbers shown in the Electrical Characteristic tables. As the output transistors deliver power, their junction temperatures increase, decreasing their V_{BEs} (increasing the available output voltage swing) and increasing their current gains (increasing the available output current). In steady-state operation, the available output voltage and current is always greater than that shown in the over-temperature specifications because the output stage junction temperatures will be higher than the minimum specified operating ambient.

To protect the output stage from accidental shorts to ground and the power supplies, output short-circuit protection is included in the OPA2690. The circuit acts to limit the maximum source or sink current to approximately 250mA.

DRIVING CAPACITIVE LOADS

One of the most demanding and yet very common load conditions for an op amp is capacitive loading. Often, the capacitive load is the input of an ADC—including additional external capacitance which may be recommended to improve ADC linearity. A high-speed, high open-loop gain amplifier like the

OPA2690 can be very susceptible to decreased stability and closed-loop response peaking when a capacitive load is placed directly on the output pin. When the amplifier's open-loop output resistance is considered, this capacitive load introduces an additional pole in the signal path that can decrease the phase margin. Several external solutions to this problem have been suggested. When the primary considerations are frequency response flatness, pulse response fidelity, and/or distortion, the simplest and most effective solution is to isolate the capacitive load from the feedback loop by inserting a series-isolation resistor between the amplifier output and the capacitive load. This does not eliminate the pole from the loop response, but rather shifts it and adds a zero at a higher frequency. The additional zero acts to cancel the phase lag from the capacitive load pole, thus increasing the phase margin and improving stability.

The Typical Characteristics show the recommended R_S versus capacitive load ([Figure 15](#) for ±5V and [Figure 30](#) for +5V) and the resulting frequency response at the load. Parasitic capacitive loads greater than 2pF can begin to degrade the performance of the OPA2690. Long PCB traces, unmatched cables, and connections to multiple devices can easily exceed this value. Always consider this effect carefully, and add the recommended series resistor as close as possible to the OPA2690 output pin (see the [Board Layout Guidelines](#) section).

The criterion for setting this R_S resistor is a maximum bandwidth, flat frequency response at the load. For the OPA2690 operating in a gain of +2, the frequency response at the output pin is already slightly peaked without the capacitive load requiring relatively high values of R_S to flatten the response at the load. Increasing the noise gain will reduce the peaking as described previously. The circuit of [Figure 48](#) demonstrates this technique, allowing lower values of R_S to be used for a given capacitive load.

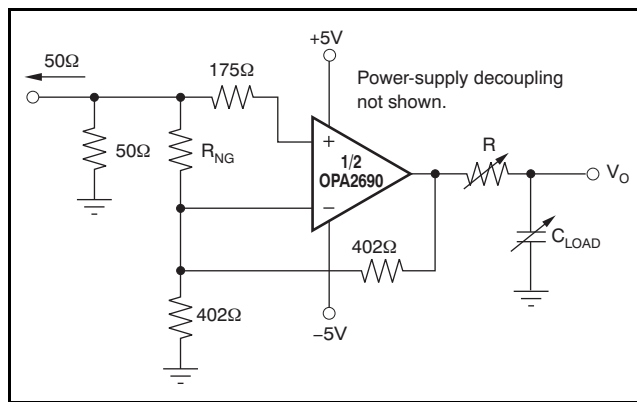

Figure 48. Capacitive Load Driving with Noise Gain Tuning

This gain of +2 circuit includes a noise gain tuning resistor across the two inputs to increase the noise gain, increasing the unloaded phase margin for the op amp. Although this technique will reduce the required R_S resistor for a given capacitive load, it does increase the noise at the output. It also will decrease the loop gain, slightly decreasing the distortion performance. If, however, the dominant distortion mechanism arises from a high R_S value, significant dynamic range improvement can be achieved using this technique. Figure 49 shows the required R_S versus C_{LOAD} parametric on noise gain using this technique. This is the circuit of Figure 48 with R_{NG} adjusted to increase the noise gain (increasing the phase margin) then sweeping C_{LOAD} and finding the required R_S to get a flat frequency response. This plot also gives the required R_S versus C_{LOAD} for the OPA2690 operated at higher signal gains without R_{NG} .

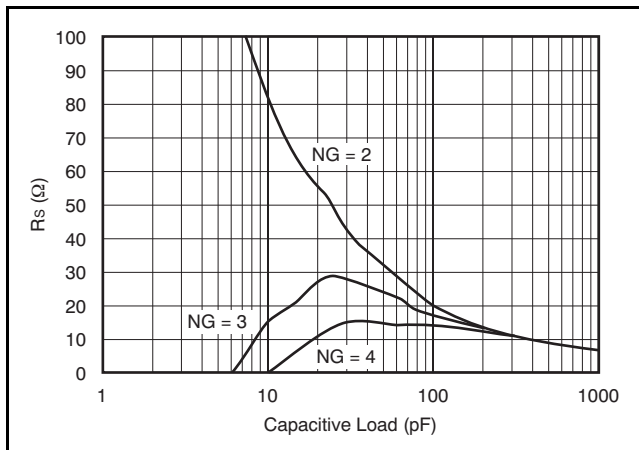

Figure 49. Required R_S vs Noise Gain

DISTORTION PERFORMANCE

The OPA2690 provides good distortion performance into a 100 Ω load on $\pm 5V$ supplies. Relative to alternative solutions, it provides exceptional performance into lighter loads and/or operating on a single +5V supply. Generally, until the fundamental signal reaches very high frequency or power levels, the 2nd-harmonic dominates the distortion with a negligible 3rd-harmonic component. Focusing then on the 2nd-harmonic, increasing the load impedance improves distortion directly. Remember that the total load includes the feedback network; in the noninverting configuration (see Figure 36), this is sum of $R_F + R_G$, while in the inverting configuration it is just R_F . Also, providing an additional supply-decoupling capacitor (0.1 μF) between the supply pins (for bipolar operation) improves the 2nd-order distortion slightly (3dB to 6dB). Operating differentially also lowers 2nd-harmonic distortion terms (see the plot on the front page).

In most op amps, increasing the output voltage swing increases harmonic distortion directly. The new output stage used in the OPA2690 actually holds the difference between fundamental power and the 2nd- and 3rd-harmonic powers relatively constant with increasing output power until very large output swings are required ($> 4V_{PP}$). This also shows up in the 2-tone, 3rd-order intermodulation spurious (IM3) response curves. The 3rd-order spurious levels are moderately low at low output power levels. The output stage continues to hold them low even as the fundamental power reaches very high levels. As the Typical Characteristics show, the spurious intermodulation powers do not increase as predicted by a traditional intercept model. As the fundamental power level increases, the dynamic range does not decrease significantly. For two tones centered at 20MHz, with 10dBm/tone into a matched 50 Ω load (that is, 2V $_{PP}$ for each tone at the load, which requires 8V $_{PP}$ for the overall two-tone envelope at the output pin), the Typical Characteristics show 46dBc difference between the test tone powers and the 3rd-order intermodulation spurious powers. This exceptional performance improves further when operating at lower frequencies or powers.

NOISE PERFORMANCE

High slew rate, unity-gain stable, voltage-feedback op amps usually achieve their slew rate at the expense of a higher input noise voltage. The 5.5nV/ \sqrt{Hz} input voltage noise for the OPA2690 is, however, much lower than comparable amplifiers. The input-referred voltage noise, and the two input-referred current noise terms, combine to give low output noise under a wide variety of operating conditions. Figure 50 shows the op amp noise analysis model with all the noise terms included. In this model, all noise terms are taken to be noise voltage or current density terms in either nV/ \sqrt{Hz} or pA/ \sqrt{Hz} .

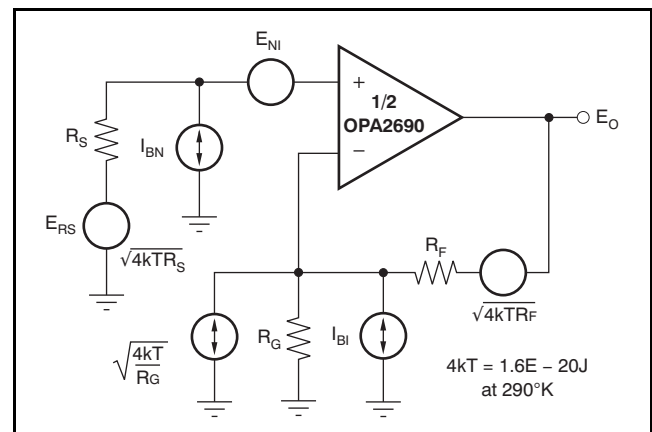

Figure 50. Op Amp Noise Analysis Model

The total output spot noise voltage can be computed as the square root of the sum of all squared output noise voltage contributors. Equation 7 shows the general form for the output noise voltage using the terms shown in Figure 50.

$$E_O = \sqrt{(E_{NI}^2 + (I_{BN}R_S)^2 + 4kTR_S)NG^2 + (I_{BI}R_F)^2 + 4kTR_FNG} \quad (7)$$

Dividing this expression by the noise gain $[NG = (1 + R_F/R_G)]$ will give the equivalent input-referred spot noise voltage at the noninverting input, as shown in Equation 8.

$$E_N = \sqrt{E_{NI}^2 + (I_{BN}R_S)^2 + 4kTR_S + \left(\frac{I_{BI}R_F}{NG}\right)^2 + \frac{4kTR_F}{NG}} \quad (8)$$

Evaluating these two equations for the OPA2690 circuit and component values (see Figure 36) gives a total output spot noise voltage of 12.3nV/√Hz and a total equivalent input spot noise voltage of 6.1nV/√Hz. This is including the noise added by the bias current cancellation resistor (175Ω) on the noninverting input. This total input-referred spot noise voltage is only slightly higher than the 5.5nV/√Hz specification for the op amp voltage noise alone. This will be the case as long as the impedances appearing at each op amp input are limited to the previously recommend maximum value of 300Ω. Keeping both $(R_F \parallel R_G)$ and the noninverting input source impedance less than 300Ω will satisfy both noise and frequency response flatness considerations. As the resistor-induced noise is relatively negligible, additional capacitive decoupling across the bias current cancellation resistor (R_B) for the inverting op amp configuration of Figure 47 is not required.

DC ACCURACY AND OFFSET CONTROL

The balanced input stage of a wideband voltage-feedback op amp allows good output dc accuracy in a wide variety of applications. The power-supply current trim for the OPA2690 gives even tighter control than comparable amplifiers. Although the high-speed input stage does require relatively high input bias current (typically 5μA out of each input terminal), the close matching between them may be used to reduce the output dc error caused by this current. The total output offset voltage may be considerably reduced by matching the dc source resistances appearing at the two inputs. This reduces the output dc error due to the input bias currents to the offset current times the feedback resistor. Evaluating the configuration of Figure 36, and using worst-case +25°C input offset voltage and current specifications, gives a worst-case output offset voltage equal to:

$$\begin{aligned} &\pm(NG \times V_{OS(MAX)}) \pm (R_F \times I_{OS(MAX)}) \\ &= \pm(2 \times 4.5mV) \pm (402\Omega \times 1\mu A) \\ &= \pm 9.4mV \quad (NG = \text{noninverting signal gain}) \end{aligned}$$

A fine-scale output offset null, or dc operating point adjustment, is often required. Numerous techniques are available for introducing dc offset control into an op amp circuit. Most of these techniques eventually reduce to adding a dc current through the feedback resistor. In selecting an offset trim method, one key consideration is the impact on the desired signal path frequency response. If the signal path is intended to be noninverting, the offset control is best applied as an inverting summing signal to avoid interaction with the signal source. If the signal path is intended to be inverting, applying the offset control to the noninverting input may be considered. However, the dc offset voltage on the summing junction will set up a dc current back into the source that must be considered. Applying an offset adjustment to the inverting op amp input can change the noise gain and frequency response flatness. For a dc-coupled inverting amplifier, Figure 51 shows one example of an offset adjustment technique that has minimal impact on the signal frequency response. In this case, the dc offsetting current is brought into the inverting input node through resistor values that are much larger than the signal path resistors. This ensures that the adjustment circuit has minimal effect on the loop gain and hence, the frequency response.

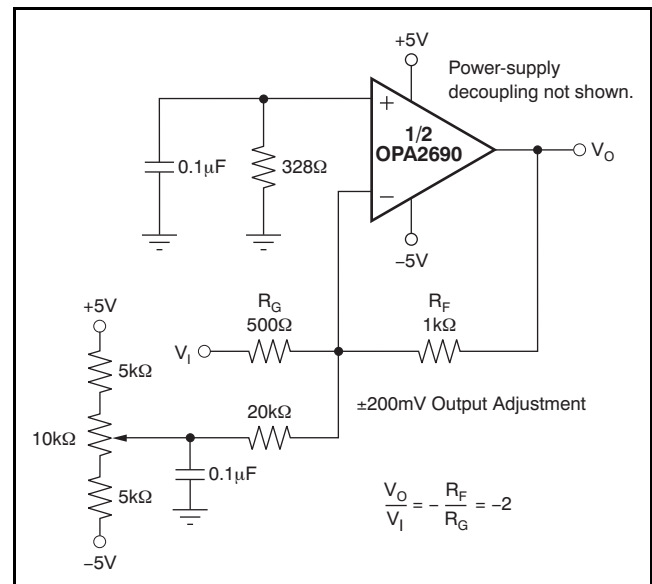

Figure 51. DC-Coupled, Inverting Gain of -2, with Offset Adjustment

DISABLE OPERATION (SO-14 Package Only)

The OPA2690-I-14D provides an optional disable feature that may be used either to reduce system power or to implement a simple channel multiplexing operation. If the DIS control pin is left unconnected, the OPA2690-I-14D will operate normally. To disable, the control pin must be asserted LOW. Figure 52 shows a simplified internal circuit for the disable control feature.

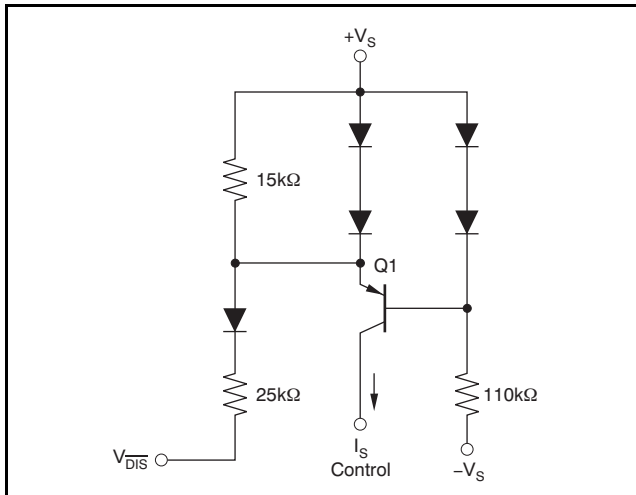

Figure 52. Simplified Disable Control Circuit

In normal operation, base current to Q1 is provided through the 110kΩ resistor, while the emitter current through the 15kΩ resistor sets up a voltage drop that is inadequate to turn on the two diodes in Q1's emitter. As $\overline{V_{DIS}}$ is pulled LOW, additional current is pulled through the 15kΩ resistor, eventually turning on those two diodes ($\approx 100\mu\text{A}$). At this point, any further current pulled out of $\overline{V_{DIS}}$ goes through those diodes holding the emitter-base voltage of Q1 at approximately 0V. This shuts off the collector current out of Q1, turning the amplifier off. The supply current in the disable mode are only those required to operate the circuit of Figure 52. Additional circuitry ensures that turn-on time occurs faster than turn-off time (make-before-break).

When disabled, the output and input nodes go to a high-impedance state. If the OPA2690 is operating at a gain of +1, this will show a very high impedance at

the output and exceptional signal isolation. If operating at a gain greater than +1, the total feedback network resistance ($R_F + R_G$) will appear as the impedance looking back into the output, but the circuit will still show very high forward and reverse isolation. If configured as an inverting amplifier, the input and output will be connected through the feedback network resistance ($R_F + R_G$) and the isolation will be very poor as a result.

One key parameter in disable operation is the output glitch when switching in and out of the disabled mode. Figure 53 shows these glitches for the circuit of Figure 36 with the input signal at 0V. The glitch waveform at the output pin is plotted along with the DIS pin voltage.

The transition edge rate (dV/dt) of the \overline{DIS} control line will influence this glitch. For the plot of Figure 53, the edge rate was reduced until no further reduction in glitch amplitude was observed. This approximately 1V/ns maximum slew rate may be achieved by adding a simple RC filter into the \overline{DIS} pin from a higher speed logic line. If extremely fast transition logic is used, a 2kΩ series resistor between the logic gate and the DIS input pin provides adequate bandlimiting using just the parasitic input capacitance on the DIS pin while still ensuring adequate logic level swing.

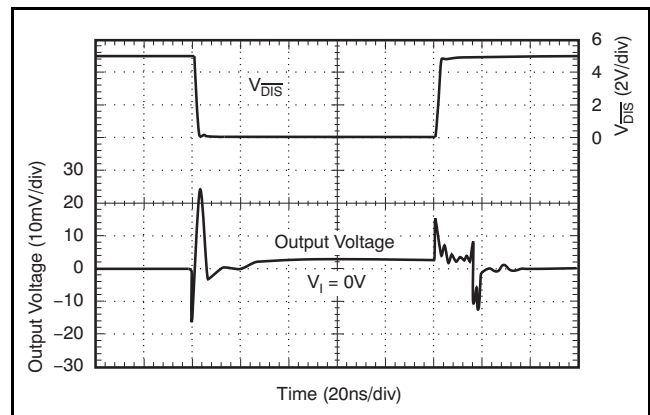

Figure 53. Disable/Enable Glitch

THERMAL ANALYSIS

Due to the high output power capability of the OPA2690, heatsinking or forced airflow may be required under extreme operating conditions. Maximum desired junction temperature will set the maximum allowed internal power dissipation as described below. In no case should the maximum junction temperature be allowed to exceed 150°C.

Operating junction temperature (T_J) is given by:

$$T_A + P_D \times \theta_{JA}$$

The total internal power dissipation (P_D) is the sum of quiescent power (P_{DQ}) and additional power dissipated in the output stage (P_{DL}) to deliver load power. Quiescent power is simply the specified no-load supply current times the total supply voltage across the part. P_{DL} depends on the required output signal and load but, for a grounded resistive load, is at a maximum when the output is fixed at a voltage equal to 1/2 of either supply voltage (for equal bipolar supplies). Under this condition, $P_{DL} = V_{S2}^2 / (4 \times R_L)$ where R_L includes feedback network loading.

Note that it is the power in the output stage and not into the load that determines internal power dissipation.

As a worst-case example, compute the maximum T_J using an OPA2690ID (SO-8 package) in the circuit of [Figure 36](#) operating at the maximum specified ambient temperature of +85°C and with both outputs driving a grounded 20Ω load to +2.5V.

$$\begin{aligned} P_D &= 10V \times 12.6mA + 2 [5^2 / (4 \times (20\Omega \parallel 804\Omega))] \\ &= 766mW \end{aligned}$$

$$\begin{aligned} \text{Maximum } T_J &= +85^\circ\text{C} + (0.766W \times 125^\circ\text{C/W}) \\ &= 180^\circ\text{C} \end{aligned}$$

This absolute worst-case condition exceeds the specified maximum junction temperature. Actual P_{DL} is normally less than that considered here. Carefully consider maximum T_J in your application.

BOARD LAYOUT GUIDELINES

Achieving optimum performance with a high-frequency amplifier like the OPA2690 requires careful attention to board layout parasitics and external component types. Recommendations that will optimize performance include:

- a. **Minimize parasitic capacitance** to any ac ground for all of the signal I/O pins. Parasitic capacitance on the output and inverting input pins can cause instability: on the noninverting input, it can react with the source impedance to cause unintentional bandlimiting. To reduce unwanted capacitance, a window around the signal I/O pins should be opened in all of the ground and power planes around those pins. Otherwise, ground and power planes should be unbroken elsewhere on the board.
- b. **Minimize the distance** (< 0.25") from the power-supply pins to high-frequency 0.1 μ F decoupling capacitors. At the device pins, the ground and power-plane layout should not be in close proximity to the signal I/O pins. Avoid narrow power and ground traces to minimize inductance between the pins and the decoupling capacitors. The power-supply connections should always be decoupled with these capacitors. An optional supply decoupling capacitor (0.1 μ F) across the two power supplies (for bipolar operation) will improve 2nd-harmonic distortion performance. Larger (2.2 μ F to 6.8 μ F) decoupling capacitors, effective at lower frequencies, should also be used on the main supply pins. These may be placed somewhat farther from the device and may be shared among several devices in the same area of the PCB.
- c. **Careful selection and placement of external components will preserve the high-frequency performance of the OPA2690.** Resistors should be a very low reactance type. Surface-mount resistors work best and allow a tighter overall layout. Metal film or carbon composition axially-leaded resistors can also provide good high-frequency performance. Again, keep their leads and PCB traces as short as possible. Never use wirewound type resistors in a high-frequency application. Since the output pin and inverting input pin are the most sensitive to parasitic capacitance, always position the feedback and series output resistor, if any, as close as possible to the output pin. Other network components, such as noninverting input termination resistors, should also be placed close to the package. Even with a low parasitic capacitance shunting the external resistors, excessively high resistor values can create significant time constants that can degrade performance. Good axial metal film or surface-mount resistors have approximately 0.2pF in shunt with the resistor. For resistor values > 1.5k Ω , this parasitic capacitance can add a pole and/or zero below 500MHz that can affect circuit operation. Keep resistor values as low as possible consistent with load driving considerations. The 402 Ω feedback used in the Electrical Characteristics is a good starting point for design. Note that a 25 Ω feedback resistor, rather than a direct short, is suggested for the unity-gain follower application. This effectively isolates the inverting input capacitance from the output pin that would otherwise cause an additional peaking in the gain of +1 frequency response.
- d. **Connections to other wideband devices** on the board may be made with short, direct traces or through onboard transmission lines. For short connections, consider the trace and the input to the next device as a lumped capacitive load. Relatively wide traces (50mils or 1,27mm to 100mils or 2,54mm) should be used, preferably with ground and power planes opened up around them. Estimate the total capacitive load and set R_S from the plot of Recommended R_S vs Capacitive Load (Figure 15 for $\pm 5V$ and Figure 30 for +5V). Low parasitic capacitive loads (< 3pF) may not need an R_S because the OPA2690 is nominally compensated to operate with a 2pF parasitic load. Higher parasitic capacitive loads without an R_S are allowed as the signal gain increases (increasing the unloaded phase margin; see Figure 49). If a long trace is required, and the 6dB signal loss intrinsic to a doubly-terminated transmission line is acceptable, implement a matched impedance transmission line using microstrip or stripline techniques (consult an ECL design handbook for microstrip and stripline layout techniques). A 50 Ω environment is normally not necessary on board, and in fact, a higher impedance environment will improve distortion as shown in the distortion versus load plots (Figure 7 for the $\pm 5v$ and Figure 32 for the +5V). With a characteristic board trace impedance defined (based on board material and trace dimensions), a matching series resistor into the trace from the output of the OPA2690 is used as well as a terminating shunt resistor at the input of the destination device. Remember also that the terminating impedance will be the parallel combination of the shunt resistor and the input impedance of the destination device; this total effective impedance should be set to match the trace impedance. The high output voltage and current capability of the OPA2690 allows multiple destination devices to be handled as separate transmission lines, each with their own series and shunt terminations. If

the 6dB attenuation of a doubly-terminated transmission line is unacceptable, a long trace can be series-terminated at the source end only. Treat the trace as a capacitive load in this case and set the series resistor value as shown in the plots of Recommended R_S vs Capacitive Load (Figure 15 for $\pm 5V$ and Figure 30 for +5V). This will not preserve signal integrity as well as a doubly-terminated line. If the input impedance of the destination device is low, there will be some signal attenuation due to the voltage divider formed by the series output into the terminating impedance.

- e. **Socketing a high-speed part like the OPA2690 is not recommended.** The additional lead length and pin-to-pin capacitance introduced by the socket can create an extremely troublesome parasitic network which can make it almost impossible to achieve a smooth, stable frequency response. Best results are obtained by soldering the OPA2690 onto the board.

INPUT AND ESD PROTECTION

The OPA2690 is built using a very high-speed complementary bipolar process. The internal junction breakdown voltages are relatively low for these very small geometry devices. These breakdowns are reflected in the [Absolute Maximum Ratings](#) table. All device pins are protected with internal ESD protection diodes to the power supplies, as shown in Figure 54.

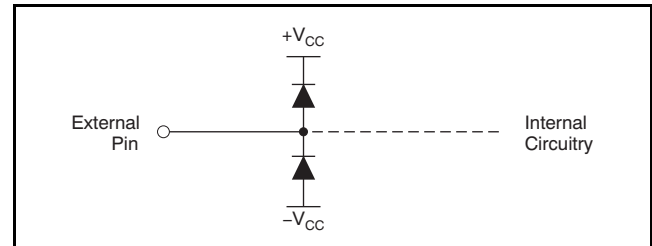

Figure 54. Internal ESD Protection

These diodes provide moderate protection to input overdrive voltages above the supplies as well. The protection diodes can typically support 30mA continuous current. Where higher currents are possible (for example, in systems with $\pm 15V$ supply parts driving into the OPA2690), current-limiting series resistors should be added into the two inputs. Keep these resistor values as low as possible since high values degrade both noise performance and frequency response.

REVISION HISTORY

NOTE: Page numbers for previous revisions may differ from page numbers in the current version.

Changes from Revision F (August 2008) to Revision G		Page
• Changed data sheet format to current standards		1
• Changed Related Products table		1
• Deleted <i>Lead Temperature</i> specification from Absolute Maximum Ratings table		2
• Changed test levels for <i>Slew Rate</i> , <i>2nd-Harmonic</i> , and <i>Channel-to-Channel Crosstalk</i> parameters		3
• Changed test level for <i>Control Pin Input Bias Current</i> parameter		5
• Changed circuit within Figure 5		7
• Added Figure 25 , Noninverting Overdrive Recovery graph		11
• Changed V_O to V_I in Figure 53		26
Changes from Revision E (May 2006) to Revision F		Page
• Changed Storage Temperature minimum value from -40°C to -65°C		2

PACKAGING INFORMATION

Orderable Device	Status (1)	Package Type	Package Drawing	Pins	Package Qty	Eco Plan (2)	Lead finish/ Ball material (6)	MSL Peak Temp (3)	Op Temp (°C)	Device Marking (4/5)	Samples
OPA2690I-14D	ACTIVE	SOIC	D	14	50	RoHS & Green	NIPDAU	Level-2-260C-1 YEAR	-40 to 85	OPA2690	Samples
OPA2690I-14DR	ACTIVE	SOIC	D	14	2500	RoHS & Green	NIPDAU	Level-2-260C-1 YEAR	-40 to 85	OPA2690	Samples
OPA2690I-14DRG4	ACTIVE	SOIC	D	14	2500	RoHS & Green	NIPDAU	Level-2-260C-1 YEAR	-40 to 85	OPA2690	Samples
OPA2690ID	ACTIVE	SOIC	D	8	75	RoHS & Green	NIPDAU	Level-2-260C-1 YEAR	-40 to 85	OPA 2690	Samples
OPA2690IDG4	ACTIVE	SOIC	D	8	75	RoHS & Green	NIPDAU	Level-2-260C-1 YEAR	-40 to 85	OPA 2690	Samples
OPA2690IDR	ACTIVE	SOIC	D	8	2500	RoHS & Green	NIPDAU	Level-2-260C-1 YEAR	-40 to 85	OPA 2690	Samples

(1) The marketing status values are defined as follows:

ACTIVE: Product device recommended for new designs.

LIFEBUY: TI has announced that the device will be discontinued, and a lifetime-buy period is in effect.

NRND: Not recommended for new designs. Device is in production to support existing customers, but TI does not recommend using this part in a new design.

PREVIEW: Device has been announced but is not in production. Samples may or may not be available.

OBSELETE: TI has discontinued the production of the device.

(2) **RoHS:** TI defines "RoHS" to mean semiconductor products that are compliant with the current EU RoHS requirements for all 10 RoHS substances, including the requirement that RoHS substance do not exceed 0.1% by weight in homogeneous materials. Where designed to be soldered at high temperatures, "RoHS" products are suitable for use in specified lead-free processes. TI may reference these types of products as "Pb-Free".

RoHS Exempt: TI defines "RoHS Exempt" to mean products that contain lead but are compliant with EU RoHS pursuant to a specific EU RoHS exemption.

Green: TI defines "Green" to mean the content of Chlorine (Cl) and Bromine (Br) based flame retardants meet JS709B low halogen requirements of <=1000ppm threshold. Antimony trioxide based flame retardants must also meet the <=1000ppm threshold requirement.

(3) MSL, Peak Temp. - The Moisture Sensitivity Level rating according to the JEDEC industry standard classifications, and peak solder temperature.

(4) There may be additional marking, which relates to the logo, the lot trace code information, or the environmental category on the device.

(5) Multiple Device Markings will be inside parentheses. Only one Device Marking contained in parentheses and separated by a "~" will appear on a device. If a line is indented then it is a continuation of the previous line and the two combined represent the entire Device Marking for that device.

⁽⁶⁾ Lead finish/Ball material - Orderable Devices may have multiple material finish options. Finish options are separated by a vertical ruled line. Lead finish/Ball material values may wrap to two lines if the finish value exceeds the maximum column width.

Important Information and Disclaimer:The information provided on this page represents TI's knowledge and belief as of the date that it is provided. TI bases its knowledge and belief on information provided by third parties, and makes no representation or warranty as to the accuracy of such information. Efforts are underway to better integrate information from third parties. TI has taken and continues to take reasonable steps to provide representative and accurate information but may not have conducted destructive testing or chemical analysis on incoming materials and chemicals. TI and TI suppliers consider certain information to be proprietary, and thus CAS numbers and other limited information may not be available for release.

In no event shall TI's liability arising out of such information exceed the total purchase price of the TI part(s) at issue in this document sold by TI to Customer on an annual basis.

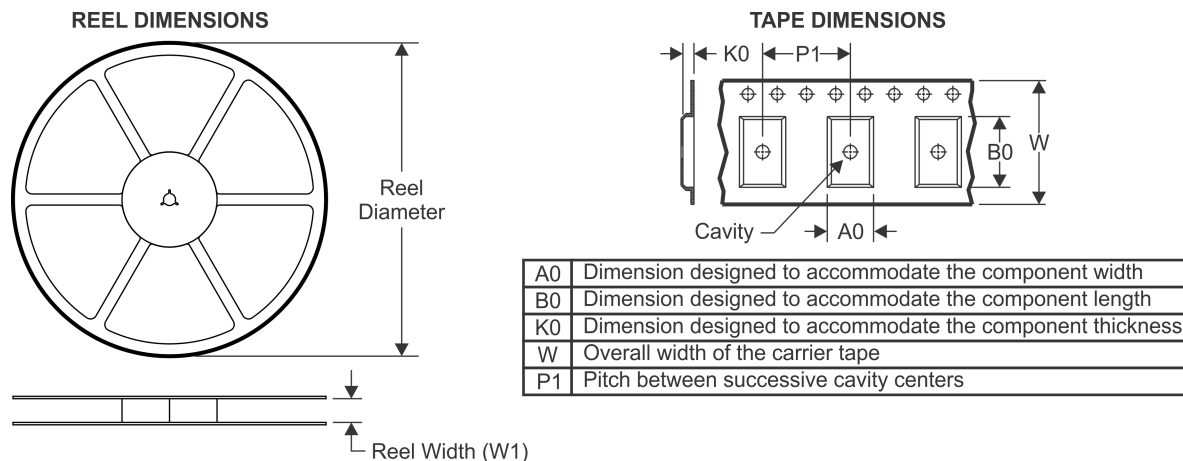
TAPE AND REEL INFORMATION

QUADRANT ASSIGNMENTS FOR PIN 1 ORIENTATION IN TAPE



*All dimensions are nominal

Device	Package Type	Package Drawing	Pins	SPQ	Reel Diameter (mm)	Reel Width W1 (mm)	A0 (mm)	B0 (mm)	K0 (mm)	P1 (mm)	W (mm)	Pin1 Quadrant
OPA2690I-14DR	SOIC	D	14	2500	330.0	16.4	6.5	9.0	2.1	8.0	16.0	Q1
OPA2690IDR	SOIC	D	8	2500	330.0	12.4	6.4	5.2	2.1	8.0	12.0	Q1

TAPE AND REEL BOX DIMENSIONS

*All dimensions are nominal

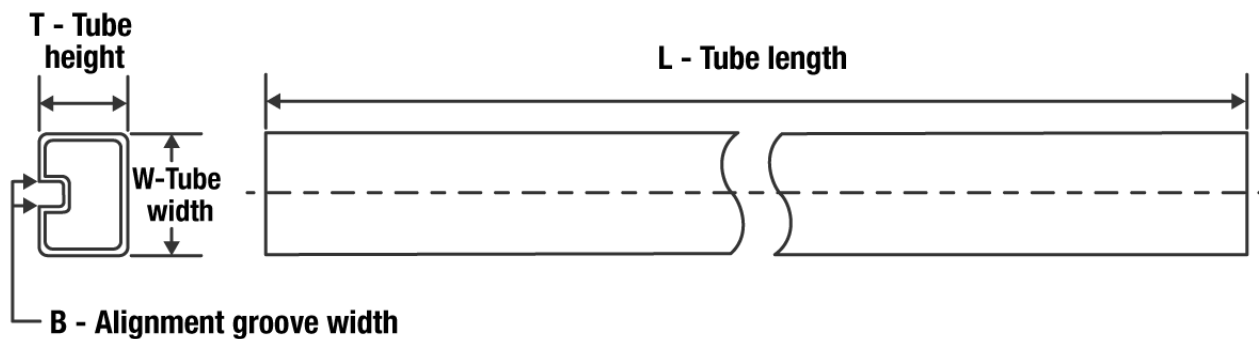
Device	Package Type	Package Drawing	Pins	SPQ	Length (mm)	Width (mm)	Height (mm)
OPA2690I-14DR	SOIC	D	14	2500	853.0	449.0	35.0
OPA2690IDR	SOIC	D	8	2500	853.0	449.0	35.0

TUBE

*All dimensions are nominal

Device	Package Name	Package Type	Pins	SPQ	L (mm)	W (mm)	T (μm)	B (mm)
OPA2690I-14D	D	SOIC	14	50	506.6	8	3940	4.32
OPA2690ID	D	SOIC	8	75	506.6	8	3940	4.32
OPA2690IDG4	D	SOIC	8	75	506.6	8	3940	4.32

D (R-PDSO-G14)

PLASTIC SMALL OUTLINE



- NOTES:
- A. All linear dimensions are in inches (millimeters).
 - B. This drawing is subject to change without notice.
 - Body length does not include mold flash, protrusions, or gate burrs. Mold flash, protrusions, or gate burrs shall not exceed 0.006 (0,15) each side.
 - Body width does not include interlead flash. Interlead flash shall not exceed 0.017 (0,43) each side.
 - E. Reference JEDEC MS-012 variation AB.

D (R-PDSO-G14)

PLASTIC SMALL OUTLINE



4211283-3/E 08/12

- NOTES:
- A. All linear dimensions are in millimeters.
 - B. This drawing is subject to change without notice.
 - C. Publication IPC-7351 is recommended for alternate designs.
 - D. Laser cutting apertures with trapezoidal walls and also rounding corners will offer better paste release. Customers should contact their board assembly site for stencil design recommendations. Refer to IPC-7525 for other stencil recommendations.
 - E. Customers should contact their board fabrication site for solder mask tolerances between and around signal pads.



D0008A

PACKAGE OUTLINE

SOIC - 1.75 mm max height

SMALL OUTLINE INTEGRATED CIRCUIT



4214825/C 02/2019

NOTES:

- Linear dimensions are in inches [millimeters]. Dimensions in parenthesis are for reference only. Controlling dimensions are in inches. Dimensioning and tolerancing per ASME Y14.5M.
- This drawing is subject to change without notice.
- This dimension does not include mold flash, protrusions, or gate burrs. Mold flash, protrusions, or gate burrs shall not exceed $.006$ [0.15] per side.
- This dimension does not include interlead flash.
- Reference JEDEC registration MS-012, variation AA.

EXAMPLE BOARD LAYOUT

D0008A

SOIC - 1.75 mm max height

SMALL OUTLINE INTEGRATED CIRCUIT



LAND PATTERN EXAMPLE
 EXPOSED METAL SHOWN
 SCALE:8X



SOLDER MASK DETAILS

4214825/C 02/2019

NOTES: (continued)

- 6. Publication IPC-7351 may have alternate designs.
- 7. Solder mask tolerances between and around signal pads can vary based on board fabrication site.

EXAMPLE STENCIL DESIGN

D0008A

SOIC - 1.75 mm max height

SMALL OUTLINE INTEGRATED CIRCUIT



SOLDER PASTE EXAMPLE
BASED ON .005 INCH [0.125 MM] THICK STENCIL
SCALE:8X

4214825/C 02/2019

NOTES: (continued)

8. Laser cutting apertures with trapezoidal walls and rounded corners may offer better paste release. IPC-7525 may have alternate design recommendations.
9. Board assembly site may have different recommendations for stencil design.

IMPORTANT NOTICE AND DISCLAIMER

TI PROVIDES TECHNICAL AND RELIABILITY DATA (INCLUDING DATA SHEETS), DESIGN RESOURCES (INCLUDING REFERENCE DESIGNS), APPLICATION OR OTHER DESIGN ADVICE, WEB TOOLS, SAFETY INFORMATION, AND OTHER RESOURCES "AS IS" AND WITH ALL FAULTS, AND DISCLAIMS ALL WARRANTIES, EXPRESS AND IMPLIED, INCLUDING WITHOUT LIMITATION ANY IMPLIED WARRANTIES OF MERCHANTABILITY, FITNESS FOR A PARTICULAR PURPOSE OR NON-INFRINGEMENT OF THIRD PARTY INTELLECTUAL PROPERTY RIGHTS.

These resources are intended for skilled developers designing with TI products. You are solely responsible for (1) selecting the appropriate TI products for your application, (2) designing, validating and testing your application, and (3) ensuring your application meets applicable standards, and any other safety, security, regulatory or other requirements.

These resources are subject to change without notice. TI grants you permission to use these resources only for development of an application that uses the TI products described in the resource. Other reproduction and display of these resources is prohibited. No license is granted to any other TI intellectual property right or to any third party intellectual property right. TI disclaims responsibility for, and you will fully indemnify TI and its representatives against, any claims, damages, costs, losses, and liabilities arising out of your use of these resources.

TI's products are provided subject to [TI's Terms of Sale](#) or other applicable terms available either on ti.com or provided in conjunction with such TI products. TI's provision of these resources does not expand or otherwise alter TI's applicable warranties or warranty disclaimers for TI products.

TI objects to and rejects any additional or different terms you may have proposed.

Mailing Address: Texas Instruments, Post Office Box 655303, Dallas, Texas 75265
Copyright © 2022, Texas Instruments Incorporated