

## 具有 SPI 接口的 TPL0501 256 抽头单通道数字电位器

### 1 特性

- 单通道 256 位置分辨率
- 100kΩ 端到端电阻选项
- 低温度系数: 35ppm/°C
- SPI 兼容串行接口
- 2.7V 至 5.5V 单电源运行
- ±20% 电阻容差
- 工作温度: -40°C 至 +125°C
- ESD 性能测试符合 JESD 22 标准
  - 2000V 人体放电模型 (A114-B, II 类)

### 2 应用

- 脉动式血氧计
- 水表
- 摄像机
- 医疗传感器贴片
- 楼宇安全网关

### 3 说明

TPL0501 器件是一款单通道线性锥形数字电位器，带有 256 个游标位置。该器件可用作三端电位器或者两端变阻器。TPL0501 现配有 100kΩ 的端到端电阻。可使用 SPI 兼容接口存取 TPL0501 的内部寄存器。TPL0501 的标称温度系数为 35ppm/°C。

TPL0501 采用 8 引脚 SOT-23 和 8 引脚 UQFN 封装，额定温度范围为 -40°C 至 +125°C。

器件信息<sup>(1)</sup>

器件型号	封装	封装尺寸 (标称值)
TPL0501	UQFN (8)	1.50mm x 1.50mm
	SOT-23 (8)	1.63mm x 2.90mm

(1) 要了解所有可用封装，请参见数据表末尾的封装选项附录。

简化原理图

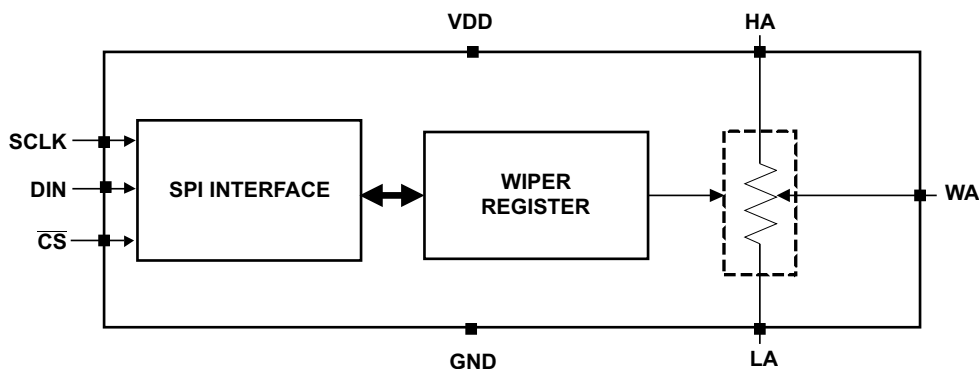

Copyright © 2016, Texas Instruments Incorporated



## 目录

1	特性 .....	1	7.5	Programming .....	11
2	应用 .....	1	<b>8</b>	<b>Application and Implementation</b> .....	<b>18</b>
3	说明 .....	1	8.1	Application Information.....	18
4	修订历史记录 .....	2	8.2	Typical Application .....	18
<b>5</b>	<b>Pin Configuration and Functions</b> .....	<b>3</b>	<b>9</b>	<b>Power Supply Recommendations</b> .....	<b>20</b>
<b>6</b>	<b>Specifications</b> .....	<b>3</b>	9.1	Power Sequence.....	20
6.1	Absolute Maximum Ratings .....	3	9.2	Wiper Position Upon Power Up .....	20
6.2	ESD Ratings .....	3	<b>10</b>	<b>Layout</b> .....	<b>20</b>
6.3	Thermal Information .....	4	10.1	Layout Guidelines .....	20
6.4	Electrical Characteristics: Analog Specifications .....	4	10.2	Layout Example .....	20
6.5	Electrical Characteristics: Operating Specifications..	5	<b>11</b>	<b>器件和文档支持</b> .....	<b>21</b>
6.6	Timing Requirements .....	5	11.1	接收文档更新通知 .....	21
6.7	Typical Characteristics .....	6	11.2	支持资源 .....	21
<b>7</b>	<b>Detailed Description</b> .....	<b>8</b>	11.3	商标 .....	21
7.1	Overview .....	8	11.4	静电放电警告 .....	21
7.2	Functional Block Diagram .....	8	11.5	Glossary .....	21
7.3	Feature Description.....	8	<b>12</b>	<b>机械、封装和可订购信息</b> .....	<b>21</b>
7.4	Device Functional Modes.....	9			

## 4 修订历史记录

注：之前版本的页码可能与当前版本有所不同。

<b>Changes from Revision B (May 2016) to Revision C</b>	<b>Page</b>
• 已更改 将说明 部分最后一句的最大温度范围从 85°C 更改为 125°C（典型值） .....	1

<b>Changes from Revision A (September 2011) to Revision B</b>	<b>Page</b>
• 添加了器件信息表、ESD 额定值表、特性说明部分、器件功能模式、应用和实施部分、电源相关建议部分、布局部分、器件和文档支持部分以及机械、封装和可订购信息部分。 .....	1
• Added register map default value in Table 1.....	11
• Changed ratio to correct form in <i>Ideal Resistance Values</i> section and in Table 2; registers names for RWL and RHW were reversed. ....	12

## 5 Pin Configuration and Functions

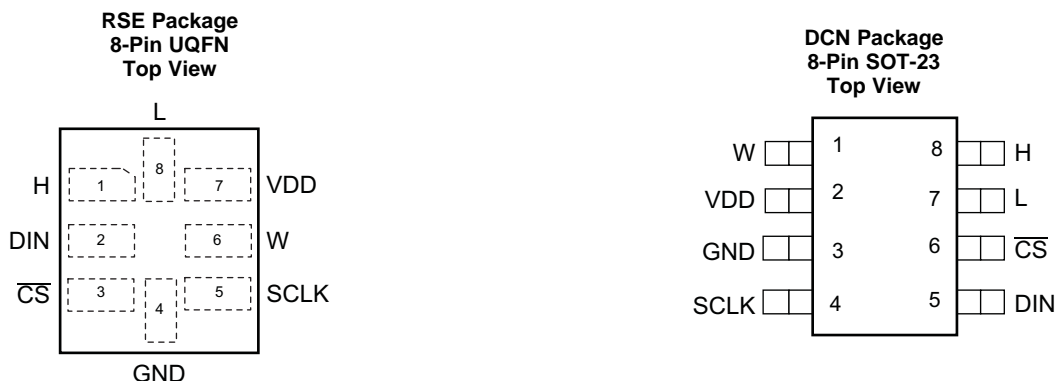

### Pin Functions

PIN			TYPE <sup>(1)</sup>	DESCRIPTION
NAME	SOT-23	UQFN		
CS	6	3	I	SPI chip select (active low)
DIN	5	2	I	SPI input
GND	3	4	G	Ground
H	8	1	I/O	High terminal
L	7	8	I/O	Low terminal
SCLK	4	5	I	SPI clock
VDD	2	7	P	Positive supply voltage
W	1	6	I/O	Wiper terminal

(1) G = Ground, I = Input, O = Output, P = Power

## 6 Specifications

### 6.1 Absolute Maximum Ratings

over operating free-air temperature range (unless otherwise noted)<sup>(1)(2)(3)</sup>

		MIN	MAX	UNIT
Supply voltage	V <sub>DD</sub> to GND	-0.3	7	V
	V <sub>H</sub> , V <sub>L</sub> , V <sub>W</sub>	-0.3	V <sub>DD</sub> + 0.3	
Pulse current, I <sub>H</sub> , I <sub>L</sub> , I <sub>W</sub>			±20	mA
Continuous current, I <sub>H</sub> , I <sub>L</sub> , I <sub>W</sub> (TPL0501-100)			±5	mA
Digital input voltage, V <sub>I</sub>		-0.3	7	V
Operating temperature, T <sub>j</sub>			125	°C
Storage temperature, T <sub>stg</sub>		-65	150	°C

- Stresses beyond those listed under *Absolute Maximum Ratings* may cause permanent damage to the device. These are stress ratings only, which do not imply functional operation of the device at these or any other conditions beyond those indicated under *Recommended Operating Conditions*. Exposure to absolute-maximum-rated conditions for extended periods may affect device reliability.
- The algebraic convention, whereby the most negative value is a minimum and the most positive value is a maximum
- All voltages are with respect to ground, unless otherwise specified.

### 6.2 ESD Ratings

			VALUE	UNIT
V <sub>(ESD)</sub>	Electrostatic discharge	Human-body model (HBM), per ANSI/ESDA/JEDEC JS-001 <sup>(1)</sup>	±2000	V
		Charged-device model (CDM), per JEDEC specification JESD22-C101 <sup>(2)</sup>	±1000	

- JEDEC document JEP155 states that 500-V HBM allows safe manufacturing with a standard ESD control process.
- JEDEC document JEP157 states that 250-V CDM allows safe manufacturing with a standard ESD control process.

### 6.3 Thermal Information

THERMAL METRIC <sup>(1)</sup>		TPL0501		UNIT
		DCN (SOT-23)	RSE (UQFN)	
		8 PINS	8 PINS	
$R_{\theta JA}$	Junction-to-ambient thermal resistance <sup>(2)</sup>	205.6	118.8	°C/W
$R_{\theta JC(top)}$	Junction-to-case (top) thermal resistance	122.3	62.4	°C/W
$R_{\theta JB}$	Junction-to-board thermal resistance	98.9	26.8	°C/W
$\psi_{JT}$	Junction-to-top characterization parameter	38.7	2.3	°C/W
$\psi_{JB}$	Junction-to-board characterization parameter	97.8	26.8	°C/W
$R_{\theta JC(bot)}$	Junction-to-case (bottom) thermal resistance	—	—	°C/W

(1) For more information about traditional and new thermal metrics, see the [Semiconductor and IC Package Thermal Metrics application report](#).

(2) The package thermal impedance is calculated in accordance with JESD 51-7.

### 6.4 Electrical Characteristics: Analog Specifications

typical values are specified at  $V_{DD} = 5\text{ V}$  and operating temperature is  $25^\circ\text{C}$  (unless otherwise noted)

PARAMETER		TEST CONDITIONS	MIN	TYP	MAX	UNIT
$R_{TOTAL}$	End-to-end resistance	Between Hi and Li terminals	80	100	120	k $\Omega$
$V_H, V_L$	Terminal voltage		0		VDD	V
$R_H, R_L$	Terminal resistance			50	150	$\Omega$
$R_W$	Wiper resistance	H terminal floating, $V_L = \text{GND}$ , Force $I_W = (V_{DD}/2) / R_{TOTAL}$ , input code = 0x80h		25	100	$\Omega$
$C_H, C_L$	Terminal capacitance	$f = 1\text{ MHz}$ , measured to GND, input code = 0x80h		15		pF
$C_W$	Wiper capacitance	$f = 1\text{ MHz}$ , measured to GND, input code = 0x80h		12		pF
$I_{LKG}$	Terminal leakage current	$V_H = \text{GND}$ to $V_{DD}$ , $V_L = \text{floating}$ or $V_L = \text{GND}$ to $V_{DD}$ , $V_H = \text{floating}$		0.1	1	$\mu\text{A}$
$TC_R$	Resistance temperature coefficient			35		ppm/°C
<b>VOLTAGE DIVIDER MODE<sup>(1)</sup></b>						
INL	Integral non-linearity		-1		1	LSB
DNL	Differential non-linearity		-0.5		0.5	LSB
Z <sub>ERROR</sub>	Zero-scale error		0	0.5	2	LSB
F <sub>ERROR</sub>	Full-scale error		-2	-0.5	0	LSB
$T_{CV}$	Ratiometric temperature coefficient	Wiper set at mid-scale		4		ppm/°C
BW	Bandwidth	Wiper set at mid-scale (TPL0501-100), $C_{LOAD} = 10\text{ pF}$		265		kHz
$T_{SW}$	Wiper settling time	TPL0501-100		3		$\mu\text{s}$
THD	Total harmonic distortion	$V_H = 1\text{ V}_{RMS}$ at 1 kHz, $V_L = V_{DD}/2$ , measurement at W		0.005%		
<b>RHEOSTAT MODE<sup>(2)</sup></b>						
RINL	Integral non-linearity		-1		1	LSB
RDNL	Differential non-linearity		-0.5		0.5	LSB
R <sub>OFFSET</sub>	Offset		0	0.5	2	LSB
RBW	Bandwidth	Code = 0x00h, L floating, input applied to W, 10 pF on H		60		kHz

(1)  $V_H = V_{DD}$ ,  $V_L = \text{GND}$ ,  $V_W = \text{not loaded}$

(2) Measurements between  $W_i$  and  $L_i$  with  $H_i$  not connected, or between  $W_i$  and  $H_i$  with  $L_i$  not connected.

## 6.5 Electrical Characteristics: Operating Specifications

typical values are specified at V<sub>DD</sub> = 5 V and operating temperature is 25°C (unless otherwise noted)

PARAMETER		TEST CONDITIONS	MIN	TYP	MAX	UNIT
I <sub>DD(STBY)</sub>	V <sub>DD</sub> standby current			0.3	8	μA
I <sub>IN-DIG</sub>	Digital pins leakage current	SCLK, DIN, $\overline{\text{CS}}$ inputs	-1		1	μA
I <sub>DD(SUPPLY)</sub>	V <sub>DD</sub> supply current	Digital input = 1.8 V, V <sub>DD</sub> = 2.7 V		5		μA
		Digital input = 1.8 V, V <sub>DD</sub> = 5 V		500		
<b>SERIAL INTERFACE<sup>(1)</sup></b>						
V <sub>IH</sub>	Input high voltage	V <sub>DD</sub> = 2.7 V to 5.5 V	1.8		5.5	V
V <sub>IL</sub>	Input low voltage	SCLK, DIN, $\overline{\text{CS}}$ inputs	0		0.6	V
C <sub>IN</sub>	Pin capacitance	SCLK, DIN, $\overline{\text{CS}}$ inputs		7	10	pF

(1) SCLK, DIN,  $\overline{\text{CS}}$  Inputs

## 6.6 Timing Requirements

		MIN	NOM	MAX	UNIT
f <sub>SCLK</sub>	SCLK frequency			25	MHz
t <sub>SCP</sub>	SCLK period	40			ns
t <sub>SCH</sub>	SCLK high time	20			ns
t <sub>SCL</sub>	SCLK low time	20			ns
t <sub>DS</sub>	DIN to SCLK set-up time	5			ns
t <sub>DH</sub>	DIN hold after SCLK	5			ns
t <sub>CSS</sub>	$\overline{\text{CS}}$ fall to SCLK rise setup time	15			ns
t <sub>CSW</sub>	$\overline{\text{CS}}$ pulse width high	40			ns

## 6.7 Typical Characteristics

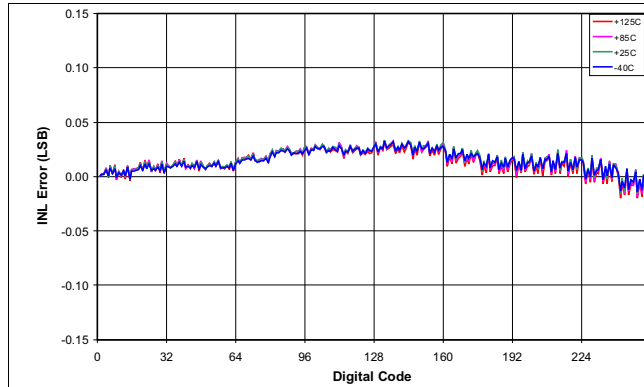

Figure 1. INL vs Tap Position (Potentiometer Mode)

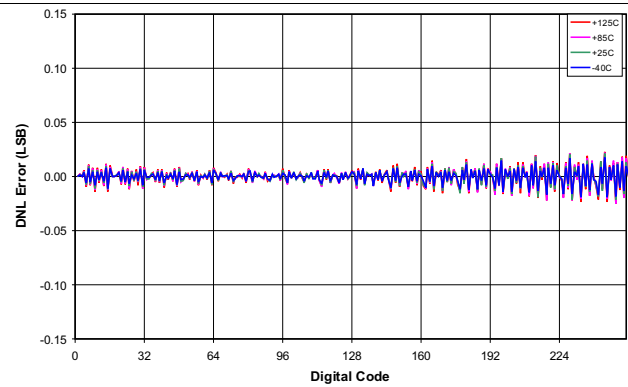

Figure 2. DNL vs Tap Position (Potentiometer Mode)

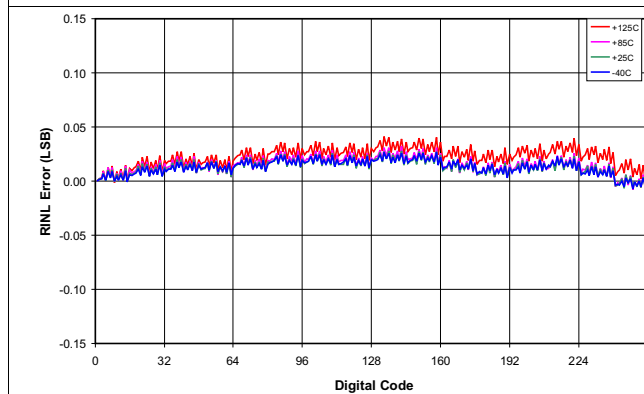

Figure 3. INL vs Tap Position (Rheostat Mode)

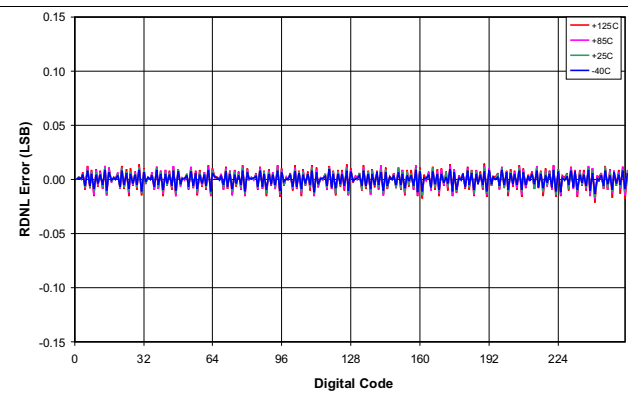

Figure 4. DNL vs Tap Position (Rheostat Mode)

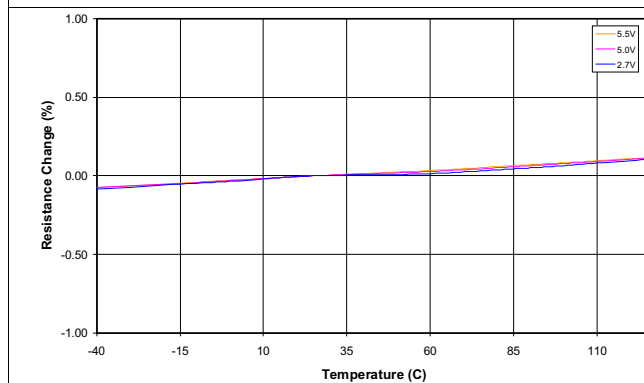

Figure 5. End-to-End Resistance Change vs Temperature

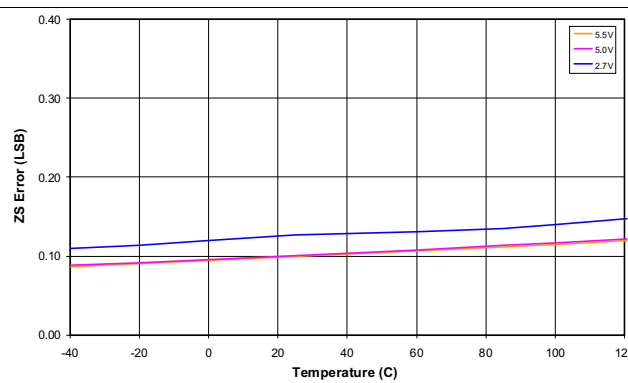
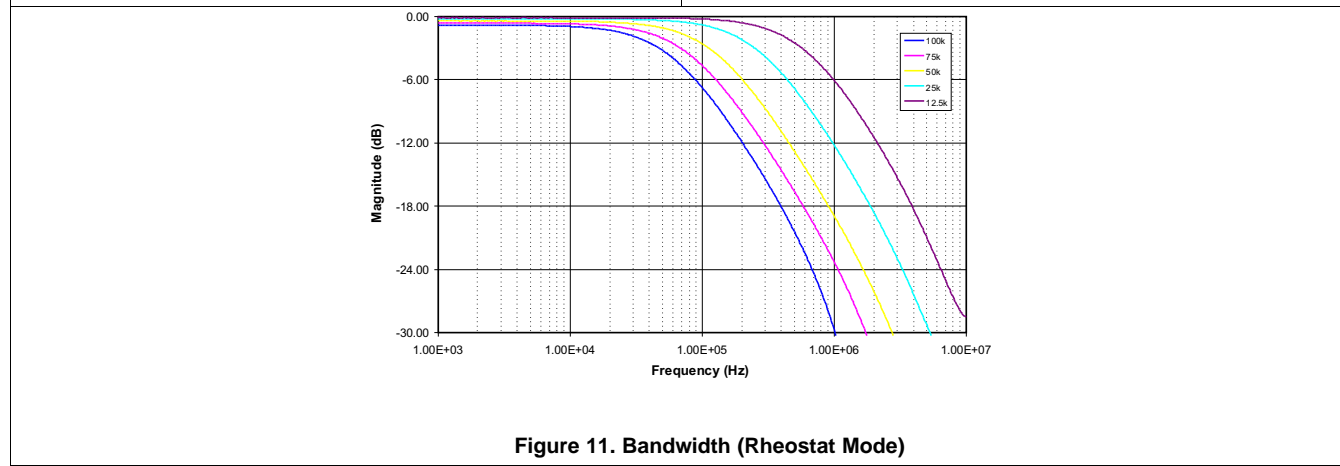
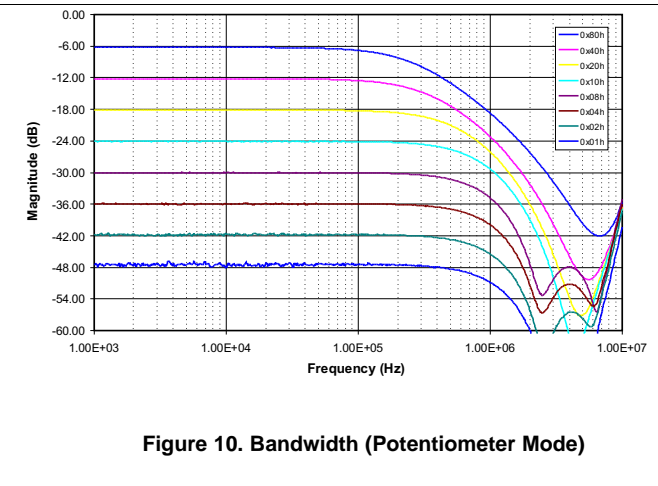
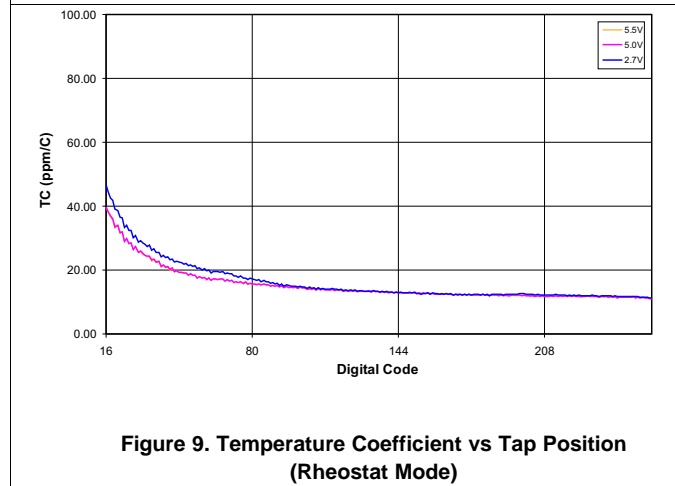
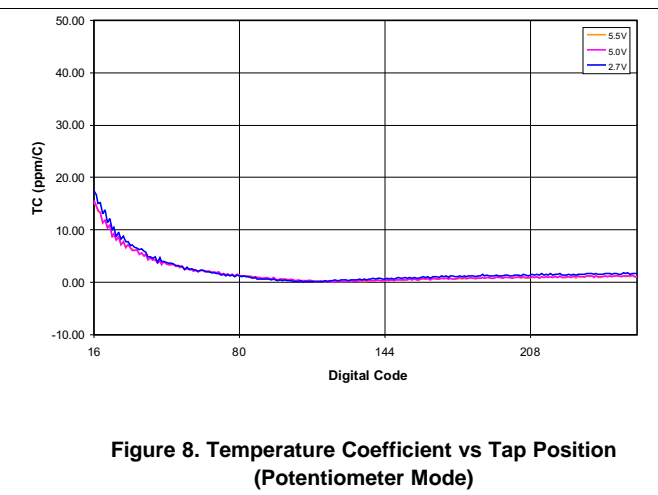
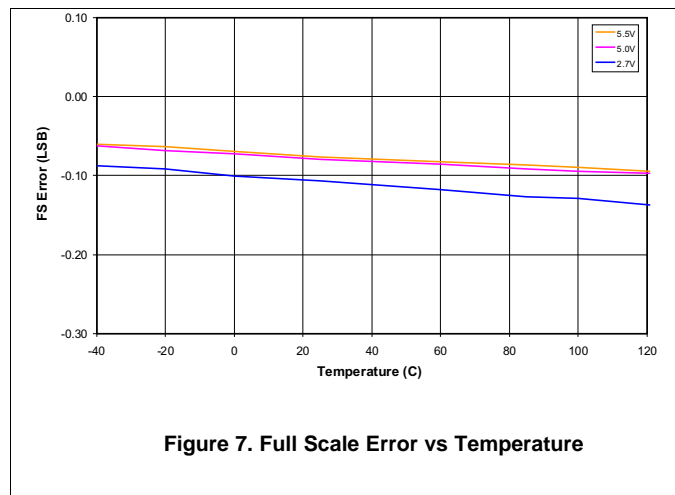

Figure 6. Zero Scale Error vs Temperature

Typical Characteristics (continued)



## 7 Detailed Description

### 7.1 Overview

The TPL0501 has a single linear-taper digital potentiometer with 256 wiper positions and an end-to-end resistance of 100 k $\Omega$ . The potentiometer can be used as a three-terminal potentiometer or as a two-terminal rheostat. The potentiometer can be used in either voltage divider mode or rheostat mode.

The high (H) and low (L) terminals of the TPL0501 are equivalent to the fixed terminals of a mechanical potentiometer. The H and L terminals do not have any polarity restrictions (H can be at a higher voltage than L, or L can be at a higher voltage than H). The position of the wiper (W) terminal is controlled by the value in the 8-bit Wiper Resistance (WR) register. When the WR register contains all zeroes (zero-scale), the wiper terminal is closest to its L terminal. As the value of the WR register increases from all zeroes to all ones (full-scale), the wiper moves from the position closest to the L terminal, to the position closest to the H terminal. At the same time, the resistance between W and L increases, whereas the resistance between W and H decreases.

### 7.2 Functional Block Diagram

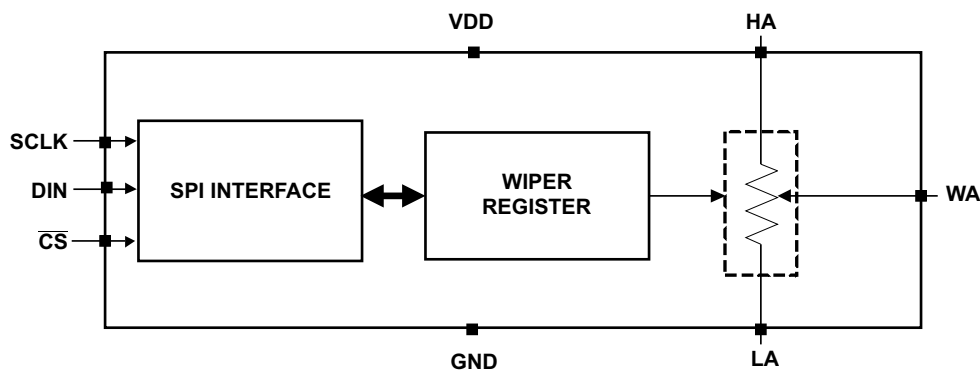

Copyright © 2016, Texas Instruments Incorporated

### 7.3 Feature Description

#### 7.3.1 Single-Channel, 256-Position Resolution

The TPL0501 features a single independent DPOT. The DPOT is capable of being used and controlled independently.

## 7.4 Device Functional Modes

### 7.4.1 Voltage Divider Mode

The digital potentiometer generates a voltage divider when all three terminals are used. The voltage divider at wiper-to-H and wiper-to-L is proportional to the input voltage at H to L (see Figure 12).

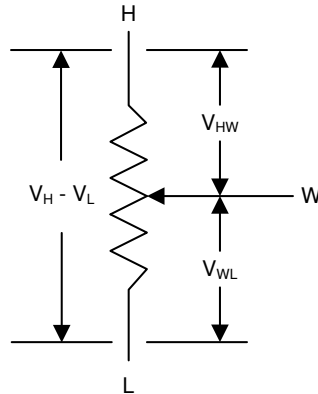

Figure 12. Equivalent Circuit for Voltage Divider Mode

For example, connecting terminal H to 5 V and terminal L to ground, the output voltage at terminal W can range from 0 V to 5 V (see Equation 1).

$$V_W = V_{WL} = (V_H - V_L) \times \frac{D}{256} \quad (1)$$

The voltage difference between terminal H and terminal W can also be calculated in Equation 2.

$$V_{HW} = (V_H - V_L) \times \left(1 - \left(\frac{D}{256}\right)\right)$$

where

- D is the decimal value of the wiper code. (2)

### 7.4.2 Rheostat Mode

The TPL0501 operates in rheostat mode when only two terminals are used as a variable resistor. The variable resistance can either be between terminal H and terminal W or between terminal L and terminal W. The unused terminal can be left floating or it can be tied to terminal W. The nominal resistance between terminal H and terminal L is 10 kΩ and has 256 tap points accessed by the wiper terminal. The 8-bit volatile register value is used to determine one of the 256 possible wiper positions.

To set the resistance between terminal H and terminal W in rheostat mode, the potentiometer can be configured in two possible ways (see Figure 13).

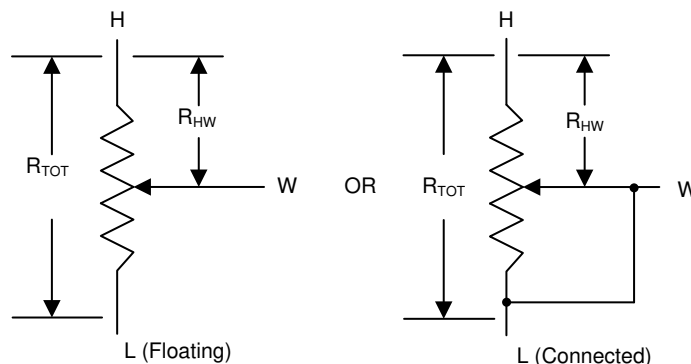

Figure 13. Equivalent Circuit for Rheostat Mode With Terminal H to Terminal W Resistance

## Device Functional Modes (continued)

The general equation for determining the digitally programmed output resistance between Terminal H and Terminal W is [Equation 3](#):

$$R_{HW} = R_{TOT} \times \left( 1 - \left( \frac{D}{256} \right) \right)$$

where

- $R_{TOT}$  is the end-to-end resistance between terminal H and terminal L.
  - D is the decimal value of the wiper code
- (3)

Similarly, to set the resistance between terminal L and terminal W, the potentiometer can be configured in two possible ways.

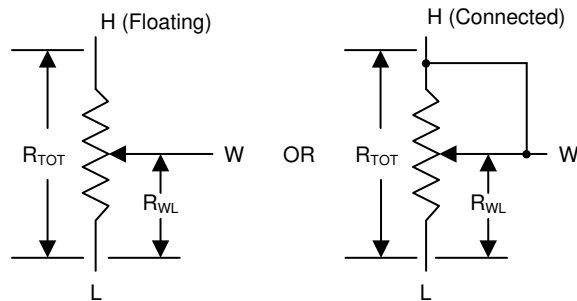

**Figure 14. Equivalent Circuit for Rheostat Mode With Terminal L to Terminal W Resistance**

The general equation for determining the digitally programmed output resistance between terminal L and terminal W is [Equation 4](#):

$$R_{WL} = R_{TOT} \times \frac{D}{256}$$

where

- $R_{TOT}$  is the end-to-end resistance between terminal H and terminal L.
  - D is the decimal value of the wiper code.
- (4)

## 7.5 Programming

### 7.5.1 SPI Digital Interface

The TPL0501 uses a 3-wire SPI compatible serial data interface. This write-only interface has three inputs: chip-select ( $\overline{CS}$ ), data clock (SCLK), and data input (DIN). Drive  $\overline{CS}$  low to enable the serial interface and clock data synchronously into the shift register on each SCLK rising edge. After loading data into the shift register, drive  $\overline{CS}$  high to latch the data into the appropriate potentiometer control register and disable the serial interface. Keep  $\overline{CS}$  low during the entire serial data stream to avoid corruption of the data.

Table 1. Register Map - Default Value 0x80

BIT7	BIT6	BIT5	BIT4	BIT3	BIT2	BIT1	BIT0
MSB							LSB
D7	D6	D5	D4	D3	D2	D1	D0

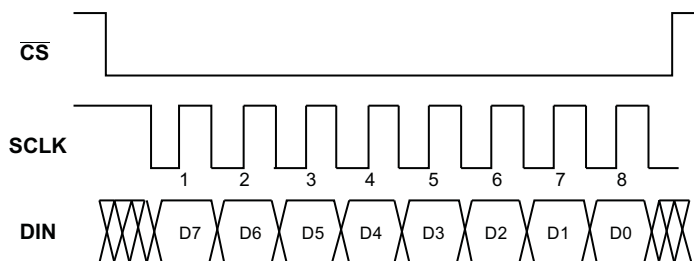

Figure 15. SPI Write Sequence

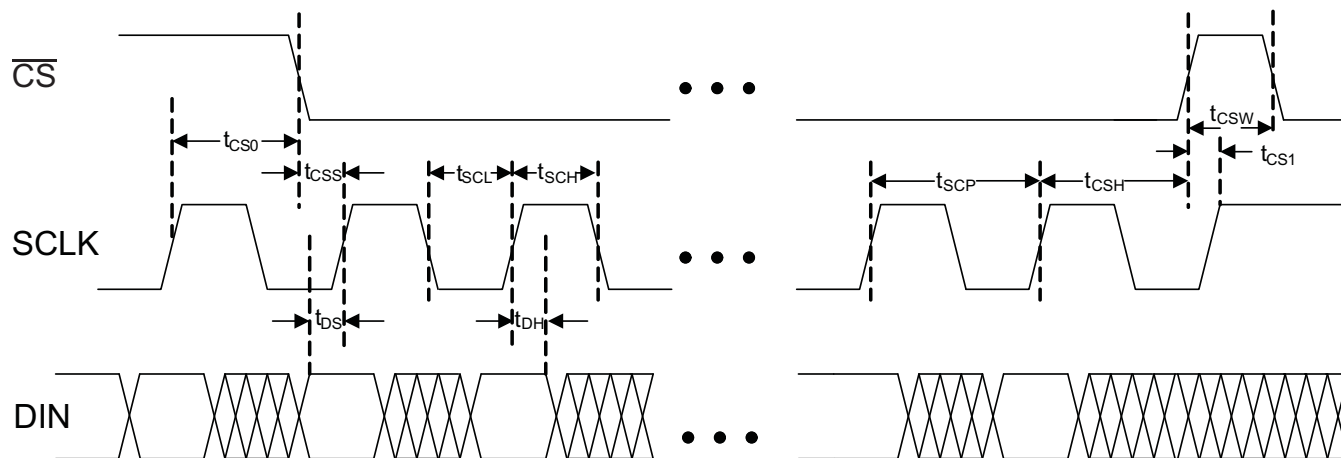

Figure 16. Digital Interface Timing Diagram

### 7.5.2 Ideal Resistance Values

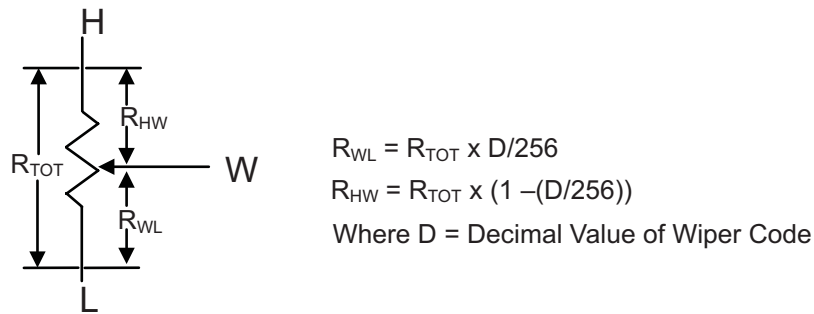

Figure 17. Digital Potentiometer Measurements

Table 2 shows the ideal values for DPOT with end-to-end resistance of 100 kΩ. The absolute values of resistance can vary significantly but the Ratio ( $R_{WL}/R_{HW}$ ) is extremely accurate.

Table 2. DPOT Ideal Values

STEP	BINARY	100 kΩ		$R_{WL}/R_{HW}$
		$R_{WL}$ (kΩ)	$R_{HW}$ (kΩ)	
0	00000000	0.00	100.00	0.00
1	00000001	0.39	99.61	0.00
2	00000010	0.78	99.22	0.01
3	00000011	1.17	98.83	0.01
4	00000100	1.56	98.44	0.02
5	00000101	1.95	98.05	0.02
6	00000110	2.34	97.66	0.02
7	00000111	2.73	97.27	0.03
8	00001000	3.13	96.88	0.03
9	00001001	3.52	96.48	0.04
10	00001010	3.91	96.09	0.04
11	00001011	4.30	95.70	0.04
12	00001100	4.69	95.31	0.05
13	00001101	5.08	94.92	0.05
14	00001110	5.47	94.53	0.06
15	00001111	5.86	94.14	0.06
16	00010000	6.25	93.75	0.07
17	00010001	6.64	93.36	0.07
18	00010010	7.03	92.97	0.08
19	00010011	7.42	92.58	0.08
20	00010100	7.81	92.19	0.08
21	00010101	8.20	91.80	0.09
22	00010110	8.59	91.41	0.09
23	00010111	8.98	91.02	0.10
24	00011000	9.38	90.63	0.10
25	00011001	9.77	90.23	0.11
26	00011010	10.16	89.84	0.11
27	00011011	10.55	89.45	0.12
28	00011100	10.94	89.06	0.12
29	00011101	11.33	88.67	0.13
30	00011110	11.72	88.28	0.13

**Table 2. DPOT Ideal Values (continued)**

STEP	BINARY	100 k $\Omega$		R <sub>WL</sub> /R <sub>HW</sub>
		R <sub>WL</sub> (k $\Omega$ )	R <sub>HW</sub> (k $\Omega$ )	
31	00011111	12.11	87.89	0.14
32	00100000	12.50	87.50	0.14
33	00100001	12.89	87.11	0.15
34	00100010	13.28	86.72	0.15
35	00100011	13.67	86.33	0.16
36	00100100	14.06	85.94	0.16
37	00100101	14.45	85.55	0.17
38	00100110	14.84	85.16	0.17
39	00100111	15.23	84.77	0.18
40	00101000	15.63	84.38	0.19
41	00101001	16.02	83.98	0.19
42	00101010	16.41	83.59	0.20
43	00101011	16.80	83.20	0.20
44	00101100	17.19	82.81	0.21
45	00101101	17.58	82.42	0.21
46	00101110	17.97	82.03	0.22
47	00101111	18.36	81.64	0.22
48	00110000	18.75	81.25	0.23
49	00110001	19.14	80.86	0.24
50	00110010	19.53	80.47	0.24
51	00110011	19.92	80.08	0.25
52	00110100	20.31	79.69	0.25
53	00110101	20.70	79.30	0.26
54	00110110	21.09	78.91	0.27
55	00110111	21.48	78.52	0.27
56	00111000	21.88	78.13	0.28
57	00111001	22.27	77.73	0.29
58	00111010	22.66	77.34	0.29
59	00111011	23.05	76.95	0.30
60	00111100	23.44	76.56	0.31
61	00111101	23.83	76.17	0.31
62	00111110	24.22	75.78	0.32
63	00111111	24.61	75.39	0.33
64	01000000	25.00	75.00	0.33
65	01000001	25.39	74.61	0.34
66	01000010	25.78	74.22	0.35
67	01000011	26.17	73.83	0.35
68	01000100	26.56	73.44	0.36
69	01000101	26.95	73.05	0.37
70	01000110	27.34	72.66	0.38
71	01000111	27.73	72.27	0.38
72	01001000	28.13	71.88	0.39
73	01001001	28.52	71.48	0.40
74	01001010	28.91	71.09	0.41
75	01001011	29.30	70.70	0.41
76	01001100	29.69	70.31	0.42

**Table 2. DPOT Ideal Values (continued)**

STEP	BINARY	100 k $\Omega$		R <sub>WL</sub> /R <sub>HW</sub>
		R <sub>WL</sub> (k $\Omega$ )	R <sub>HW</sub> (k $\Omega$ )	
77	01001101	30.08	69.92	0.43
78	01001110	30.47	69.53	0.44
79	01001111	30.86	69.14	0.45
80	01010000	31.25	68.75	0.45
81	01010001	31.64	68.36	0.46
82	01010010	32.03	67.97	0.47
83	01010011	32.42	67.58	0.48
84	01010100	32.81	67.19	0.49
85	01010101	33.20	66.80	0.50
86	01010110	33.59	66.41	0.51
87	01010111	33.98	66.02	0.51
88	01011000	34.38	65.63	0.52
89	01011001	34.77	65.23	0.53
90	01011010	35.16	64.84	0.54
91	01011011	35.55	64.45	0.55
92	01011100	35.94	64.06	0.56
93	01011101	36.33	63.67	0.57
94	01011110	36.72	63.28	0.58
95	01011111	37.11	62.89	0.59
96	01100000	37.50	62.50	0.60
97	01100001	37.89	62.11	0.61
98	01100010	38.28	61.72	0.62
99	01100011	38.67	61.33	0.63
100	01100100	39.06	60.94	0.64
101	01100101	39.45	60.55	0.65
102	01100110	39.84	60.16	0.66
103	01100111	40.23	59.77	0.67
104	01101000	40.63	59.38	0.68
105	01101001	41.02	58.98	0.70
106	01101010	41.41	58.59	0.71
107	01101011	41.80	58.20	0.72
108	01101100	42.19	57.81	0.73
109	01101101	42.58	57.42	0.74
110	01101110	42.97	57.03	0.75
111	01101111	43.36	56.64	0.77
112	01110000	43.75	56.25	0.78
113	01110001	44.14	55.86	0.79
114	01110010	44.53	55.47	0.80
115	01110011	44.92	55.08	0.82
116	01110100	45.31	54.69	0.83
117	01110101	45.70	54.30	0.84
118	01110110	46.09	53.91	0.86
119	01110111	46.48	53.52	0.87
120	01111000	46.88	53.13	0.88
121	01111001	47.27	52.73	0.90
122	01111010	47.66	52.34	0.91

**Table 2. DPOT Ideal Values (continued)**

STEP	BINARY	100 k $\Omega$		R <sub>WL</sub> /R <sub>HW</sub>
		R <sub>WL</sub> (k $\Omega$ )	R <sub>HW</sub> (k $\Omega$ )	
123	01111011	48.05	51.95	0.92
124	01111100	48.44	51.56	0.94
125	01111101	48.83	51.17	0.95
126	01111110	49.22	50.78	0.97
127	01111111	49.61	50.39	0.98
128	10000000	50.00	50.00	1.00
129	10000001	50.39	49.61	1.02
130	10000010	50.78	49.22	1.03
131	10000011	51.17	48.83	1.05
132	10000100	51.56	48.44	1.06
133	10000101	51.95	48.05	1.08
134	10000110	52.34	47.66	1.10
135	10000111	52.73	47.27	1.12
136	10001000	53.13	46.88	1.13
137	10001001	53.52	46.48	1.15
138	10001010	53.91	46.09	1.17
139	10001011	54.30	45.70	1.19
140	10001100	54.69	45.31	1.21
141	10001101	55.08	44.92	1.23
142	10001110	55.47	44.53	1.25
143	10001111	55.86	44.14	1.27
144	10010000	56.25	43.75	1.29
145	10010001	56.64	43.36	1.31
146	10010010	57.03	42.97	1.33
147	10010011	57.42	42.58	1.35
148	10010100	57.81	42.19	1.37
149	10010101	58.20	41.80	1.39
150	10010110	58.59	41.41	1.42
151	10010111	58.98	41.02	1.44
152	10011000	59.38	40.63	1.46
153	10011001	59.77	40.23	1.49
154	10011010	60.16	39.84	1.51
155	10011011	60.55	39.45	1.53
156	10011100	60.94	39.06	1.56
157	10011101	61.33	38.67	1.59
158	10011110	61.72	38.28	1.61
159	10011111	62.11	37.89	1.64
160	10100000	62.50	37.50	1.67
161	10100001	62.89	37.11	1.69
162	10100010	63.28	36.72	1.72
163	10100011	63.67	36.33	1.75
164	10100100	64.06	35.94	1.78
165	10100101	64.45	35.55	1.81
166	10100110	64.84	35.16	1.84
167	10100111	65.23	34.77	1.88
168	10101000	65.63	34.38	1.91

**Table 2. DPOT Ideal Values (continued)**

STEP	BINARY	100 k $\Omega$		R <sub>WL</sub> /R <sub>HW</sub>
		R <sub>WL</sub> (k $\Omega$ )	R <sub>HW</sub> (k $\Omega$ )	
169	10101001	66.02	33.98	1.94
170	10101010	66.41	33.59	1.98
171	10101011	66.80	33.20	2.01
172	10101100	67.19	32.81	2.05
173	10101101	67.58	32.42	2.08
174	10101110	67.97	32.03	2.12
175	10101111	68.36	31.64	2.16
176	10110000	68.75	31.25	2.20
177	10110001	69.14	30.86	2.24
178	10110010	69.53	30.47	2.28
179	10110011	69.92	30.08	2.32
180	10110100	70.31	29.69	2.37
181	10110101	70.70	29.30	2.41
182	10110110	71.09	28.91	2.46
183	10110111	71.48	28.52	2.51
184	10111000	71.88	28.13	2.56
185	10111001	72.27	27.73	2.61
186	10111010	72.66	27.34	2.66
187	10111011	73.05	26.95	2.71
188	10111100	73.44	26.56	2.76
189	10111101	73.83	26.17	2.82
190	10111110	74.22	25.78	2.88
191	10111111	74.61	25.39	2.94
192	11000000	75.00	25.00	3.00
193	11000001	75.39	24.61	3.06
194	11000010	75.78	24.22	3.13
195	11000011	76.17	23.83	3.20
196	11000100	76.56	23.44	3.27
197	11000101	76.95	23.05	3.34
198	11000110	77.34	22.66	3.41
199	11000111	77.73	22.27	3.49
200	11001000	78.13	21.88	3.57
201	11001001	78.52	21.48	3.65
202	11001010	78.91	21.09	3.74
203	11001011	79.30	20.70	3.83
204	11001100	79.69	20.31	3.92
205	11001101	80.08	19.92	4.02
206	11001110	80.47	19.53	4.12
207	11001111	80.86	19.14	4.22
208	11010000	81.25	18.75	4.33
209	11010001	81.64	18.36	4.45
210	11010010	82.03	17.97	4.57
211	11010011	82.42	17.58	4.69
212	11010100	82.81	17.19	4.82
213	11010101	83.20	16.80	4.95
214	11010110	83.59	16.41	5.10

**Table 2. DPOT Ideal Values (continued)**

STEP	BINARY	100 k $\Omega$		R <sub>WL</sub> /R <sub>HW</sub>
		R <sub>WL</sub> (k $\Omega$ )	R <sub>HW</sub> (k $\Omega$ )	
215	11010111	83.98	16.02	5.24
216	11011000	84.38	15.63	5.40
217	11011001	84.77	15.23	5.56
218	11011010	85.16	14.84	5.74
219	11011011	85.55	14.45	5.92
220	11011100	85.94	14.06	6.11
221	11011101	86.33	13.67	6.31
222	11011110	86.72	13.28	6.53
223	11011111	87.11	12.89	6.76
224	11100000	87.50	12.50	7.00
225	11100001	87.89	12.11	7.26
226	11100010	88.28	11.72	7.53
227	11100011	88.67	11.33	7.83
228	11100100	89.06	10.94	8.14
229	11100101	89.45	10.55	8.48
230	11100110	89.84	10.16	8.85
231	11100111	90.23	9.77	9.24
232	11101000	90.63	9.38	9.67
233	11101001	91.02	8.98	10.13
234	11101010	91.41	8.59	10.64
235	11101011	91.80	8.20	11.19
236	11101100	92.19	7.81	11.80
237	11101101	92.58	7.42	12.47
238	11101110	92.97	7.03	13.22
239	11101111	93.36	6.64	14.06
240	11110000	93.75	6.25	15.00
241	11110001	94.14	5.86	16.07
242	11110010	94.53	5.47	17.29
243	11110011	94.92	5.08	18.69
244	11110100	95.31	4.69	20.33
245	11110101	95.70	4.30	22.27
246	11110110	96.09	3.91	24.60
247	11110111	96.48	3.52	27.44
248	11111000	96.88	3.13	31.00
249	11111001	97.27	2.73	35.57
250	11111010	97.66	2.34	41.67
251	11111011	98.05	1.95	50.20
252	11111100	98.44	1.56	63.00
253	11111101	98.83	1.17	84.33
254	11111110	99.22	0.78	127.00
255	11111111	99.61	0.39	255.00

## 8 Application and Implementation

### NOTE

Information in the following applications sections is not part of the TI component specification, and TI does not warrant its accuracy or completeness. TI's customers are responsible for determining suitability of components for their purposes. Customers should validate and test their design implementation to confirm system functionality.

### 8.1 Application Information

Many applications require using a digital potentiometer such as the TPL0501 for variable resistance or voltage division. *Typical Application* shows one of these examples. In conjunction with various amplifiers, the TPL0501 can effectively be used in rheostat mode to modify the gain of an amplifier in voltage divider mode to create a digital-to-analog converter (DAC).

### 8.2 Typical Application

Figure 18 shows a DAC.

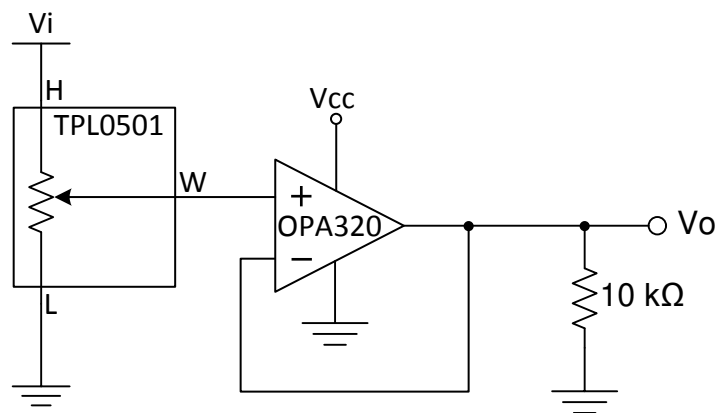

Copyright © 2016, Texas Instruments Incorporated

**Figure 18. DAC Schematic**

#### 8.2.1 Design Requirements

Table 3 lists the design parameters for this application.

**Table 3. Example Parameters**

DESIGN PARAMETER	EXAMPLE VALUE
Input voltage	0 V to 5 V
Output voltage	0 V to 5 V

#### 8.2.2 Detailed Design Procedure

The TPL0501 can be used in voltage divider mode with a unity-gain operational amplifier buffer to create an 8-bit DAC. The analog output voltage of the circuit is determined by the wiper setting programmed through the SPI Interface.

The operational amplifier is required to buffer the high-impedance output of the TPL0501 or else loading placed on the output of the voltage divider affects the output voltage.

### 8.2.3 Application Curve

The voltage at terminal H determines the maximum analog voltage at the output. As the TPL0501 moves from zero-scale to full-scale, the voltage divider adjusts with relation to the voltage divider formula (see Figure 12), resulting in the desired voltage at terminal W. The voltage at terminal W ranges linearly from 0 V to the terminal H voltage. In this example,  $V_{IN}$  at terminal H is 5 V and 2.7 V.

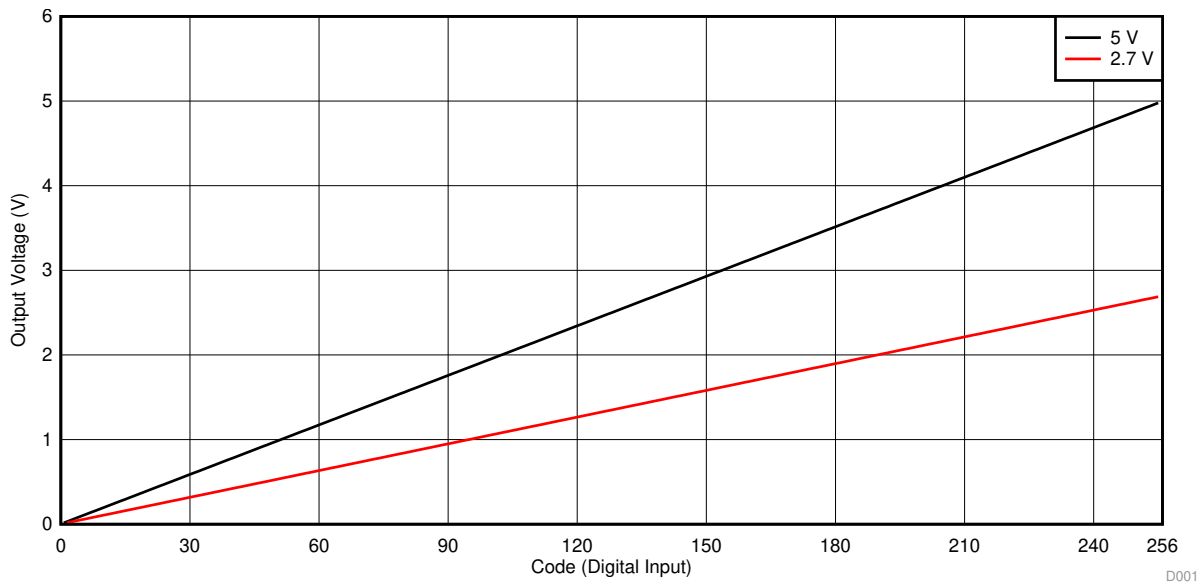

Figure 19. TPL0501 Digital Input vs OPA320 Analog Output (DAC)

## 9 Power Supply Recommendations

### 9.1 Power Sequence

Protection diodes limit the voltage compliance at terminal H, terminal L, and terminal W, making it important to power up  $V_{DD}$  first before applying any voltage to terminal H, terminal L, and terminal W. The diodes are forward-biasing, meaning  $V_{DD}$  is not powered first. The ideal power up sequence is  $V_{DD}$ , digital inputs, and  $V_H$ ,  $V_L$ , and  $V_W$ . The order of powering digital inputs,  $V_H$ ,  $V_L$ , and  $V_W$  does not matter as long as they are powered after  $V_{DD}$ .

### 9.2 Wiper Position Upon Power Up

It is prudent to know that when DPOT is powered off, the impedance of the device is not known. Upon power up, the device will return to 0x80h code because this device does not contain non-volatile memory.

## 10 Layout

### 10.1 Layout Guidelines

To maintain reliability of the device, follow common printed-circuit board (PCB) layout guidelines.

- Leads to the input must be as direct as possible with a minimum conductor length.
- The ground path must have low resistance and low inductance.
- Use short trace-lengths to avoid excessive loading.
- It is common to have a dedicated ground plane on an inner layer of the board.
- Terminals that are connected to ground must have a low-impedance path to the ground plane in the form of wide polygon pours and multiple vias.
- Use bypass capacitors on power supplies and placed them as close as possible to the  $V_{DD}$  pin.
- Apply low equivalent series resistance (0.1- $\mu$ F to 10- $\mu$ F tantalum or electrolytic capacitors) at the supplies to minimize transient disturbances and to filter low frequency ripple.

### 10.2 Layout Example

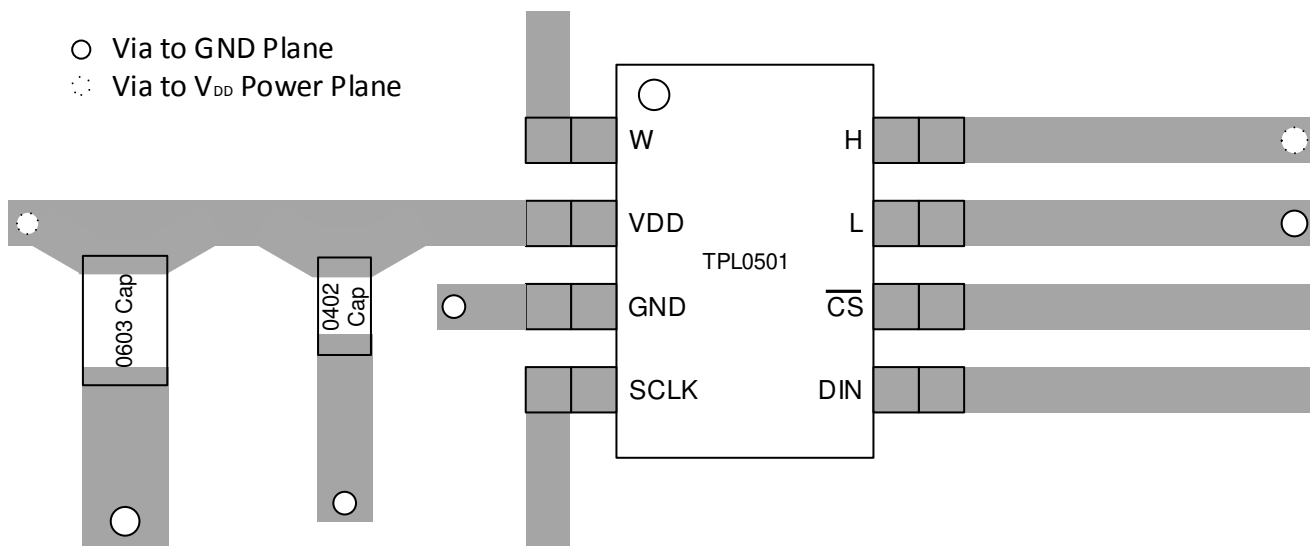

**Figure 20. Example Layout for DCN Package**

## 11 器件和文档支持

### 11.1 接收文档更新通知

要接收文档更新通知，请导航至 [ti.com](http://ti.com) 上的器件产品文件夹。单击右上角的通知我进行注册，即可每周接收产品信息更改摘要。有关更改的详细信息，请查看任何已修订文档中包含的修订历史记录。

### 11.2 支持资源

TI E2E™ [support forums](#) are an engineer's go-to source for fast, verified answers and design help — straight from the experts. Search existing answers or ask your own question to get the quick design help you need.

Linked content is provided "AS IS" by the respective contributors. They do not constitute TI specifications and do not necessarily reflect TI's views; see TI's [Terms of Use](#).

### 11.3 商标

E2E is a trademark of Texas Instruments.

All other trademarks are the property of their respective owners.

### 11.4 静电放电警告



这些装置包含有限的内置 ESD 保护。存储或装卸时，应将导线一起截短或将装置放置于导电泡棉中，以防止 MOS 门极遭受静电损伤。

### 11.5 Glossary

[SLYZ022](#) — *TI Glossary*.

This glossary lists and explains terms, acronyms, and definitions.

## 12 机械、封装和可订购信息

以下页面包含机械、封装和可订购信息。这些信息是指定器件的最新可用数据。数据如有变更，恕不另行通知，且不会对此文档进行修订。如需获取此数据表的浏览器版本，请查阅左侧的导航栏。

## 重要声明和免责声明

TI 均以“原样”提供技术性数据（包括数据表）、设计资源（包括参考设计）、应用或其他设计建议、网络工具、安全信息和其他资源，不保证其中不含任何瑕疵，且不做任何明示或暗示的担保，包括但不限于对适销性、适合某特定用途或不侵犯任何第三方知识产权的暗示担保。

所述资源可供专业开发人员应用TI 产品进行设计使用。您将对以下行为独自承担全部责任：(1) 针对您的应用选择合适的TI 产品；(2) 设计、验证并测试您的应用；(3) 确保您的应用满足相应标准以及任何其他安全、安保或其他要求。所述资源如有变更，恕不另行通知。TI 对您使用所述资源的授权仅限于开发资源所涉及TI 产品的相关应用。除此之外不得复制或展示所述资源，也不提供其它TI 或任何第三方的知识产权授权许可。如因使用所述资源而产生任何索赔、赔偿、成本、损失及债务等，TI 对此概不负责，并且您须赔偿由此对TI 及其代表造成的损害。

TI 所提供产品均受TI 的销售条款 (<http://www.ti.com.cn/zh-cn/legal/termsofsale.html>) 以及ti.com.cn上或随附TI产品提供的其他可适用条款的约束。TI提供所述资源并不扩展或以其他方式更改TI 针对TI 产品所发布的可适用的担保范围或担保免责声明。

邮寄地址：上海市浦东新区世纪大道 1568 号中建大厦 32 楼，邮政编码：200122  
Copyright © 2019 德州仪器半导体技术（上海）有限公司

**PACKAGING INFORMATION**

Orderable Device	Status (1)	Package Type	Package Drawing	Pins	Package Qty	Eco Plan (2)	Lead finish/ Ball material (6)	MSL Peak Temp (3)	Op Temp (°C)	Device Marking (4/5)	Samples
TPL0501-100DCNR	ACTIVE	SOT-23	DCN	8	3000	RoHS & Green	NIPDAU	Level-1-260C-UNLIM	-40 to 125	(NF5J, NF5T)	<a href="#">Samples</a>
TPL0501-100RSER	ACTIVE	UQFN	RSE	8	5000	RoHS & Green	NIPDAUAG	Level-1-260C-UNLIM	-40 to 125	7M	<a href="#">Samples</a>

(1) The marketing status values are defined as follows:

**ACTIVE:** Product device recommended for new designs.

**LIFEBUY:** TI has announced that the device will be discontinued, and a lifetime-buy period is in effect.

**NRND:** Not recommended for new designs. Device is in production to support existing customers, but TI does not recommend using this part in a new design.

**PREVIEW:** Device has been announced but is not in production. Samples may or may not be available.

**OBSOLETE:** TI has discontinued the production of the device.

(2) **RoHS:** TI defines "RoHS" to mean semiconductor products that are compliant with the current EU RoHS requirements for all 10 RoHS substances, including the requirement that RoHS substance do not exceed 0.1% by weight in homogeneous materials. Where designed to be soldered at high temperatures, "RoHS" products are suitable for use in specified lead-free processes. TI may reference these types of products as "Pb-Free".

**RoHS Exempt:** TI defines "RoHS Exempt" to mean products that contain lead but are compliant with EU RoHS pursuant to a specific EU RoHS exemption.

**Green:** TI defines "Green" to mean the content of Chlorine (Cl) and Bromine (Br) based flame retardants meet JS709B low halogen requirements of <=1000ppm threshold. Antimony trioxide based flame retardants must also meet the <=1000ppm threshold requirement.

(3) MSL, Peak Temp. - The Moisture Sensitivity Level rating according to the JEDEC industry standard classifications, and peak solder temperature.

(4) There may be additional marking, which relates to the logo, the lot trace code information, or the environmental category on the device.

(5) Multiple Device Markings will be inside parentheses. Only one Device Marking contained in parentheses and separated by a "~" will appear on a device. If a line is indented then it is a continuation of the previous line and the two combined represent the entire Device Marking for that device.

(6) Lead finish/Ball material - Orderable Devices may have multiple material finish options. Finish options are separated by a vertical ruled line. Lead finish/Ball material values may wrap to two lines if the finish value exceeds the maximum column width.

**Important Information and Disclaimer:**The information provided on this page represents TI's knowledge and belief as of the date that it is provided. TI bases its knowledge and belief on information provided by third parties, and makes no representation or warranty as to the accuracy of such information. Efforts are underway to better integrate information from third parties. TI has taken and continues to take reasonable steps to provide representative and accurate information but may not have conducted destructive testing or chemical analysis on incoming materials and chemicals. TI and TI suppliers consider certain information to be proprietary, and thus CAS numbers and other limited information may not be available for release.

In no event shall TI's liability arising out of such information exceed the total purchase price of the TI part(s) at issue in this document sold by TI to Customer on an annual basis.



## TAPE AND REEL INFORMATION



### QUADRANT ASSIGNMENTS FOR PIN 1 ORIENTATION IN TAPE



\*All dimensions are nominal

Device	Package Type	Package Drawing	Pins	SPQ	Reel Diameter (mm)	Reel Width W1 (mm)	A0 (mm)	B0 (mm)	K0 (mm)	P1 (mm)	W (mm)	Pin1 Quadrant
TPL0501-100DCNR	SOT-23	DCN	8	3000	180.0	8.4	3.23	3.17	1.37	4.0	8.0	Q3
TPL0501-100RSER	UQFN	RSE	8	5000	180.0	8.4	1.7	1.7	0.7	4.0	8.0	Q1

**TAPE AND REEL BOX DIMENSIONS**

\*All dimensions are nominal

Device	Package Type	Package Drawing	Pins	SPQ	Length (mm)	Width (mm)	Height (mm)
TPL0501-100DCNR	SOT-23	DCN	8	3000	202.0	201.0	28.0
TPL0501-100RSER	UQFN	RSE	8	5000	202.0	201.0	28.0

DCN (R-PDSO-G8)

PLASTIC SMALL-OUTLINE PACKAGE (DIE DOWN)

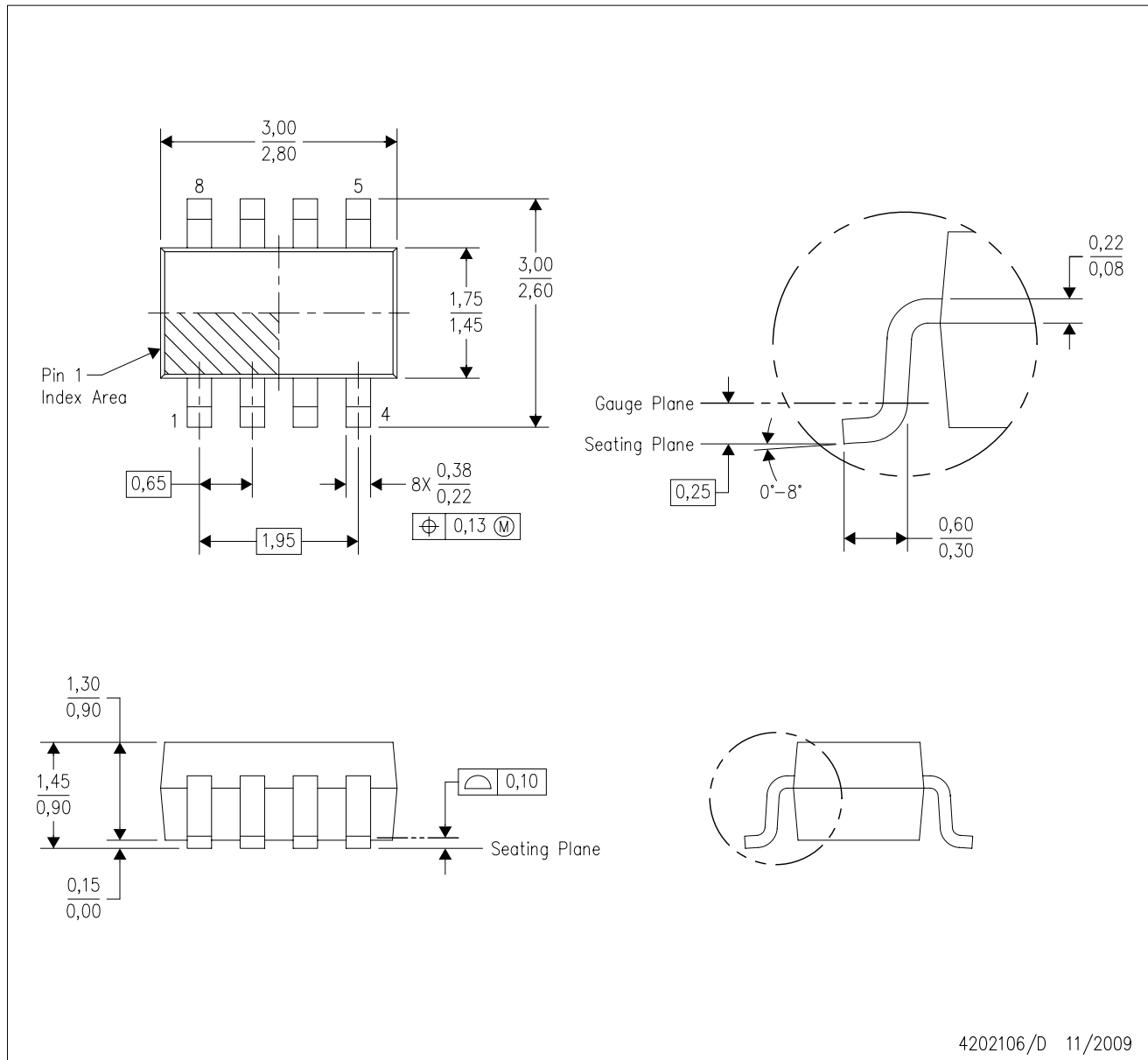

- NOTES:
- A. All linear dimensions are in millimeters.
  - B. This drawing is subject to change without notice.
  - C. Package outline exclusive of metal burr & dambar protrusion/intrusion.
  - D. Package outline inclusive of solder plating.
  - E. A visual index feature must be located within the Pin 1 index area.
  - F. Falls within JEDEC MO-178 Variation BA.
  - G. Body dimensions do not include flash or protrusion. Mold flash and protrusion shall not exceed 0.25 per side.

DCN (R-PDSO-G8)

PLASTIC SMALL-OUTLINE PACKAGE (DIE DOWN)

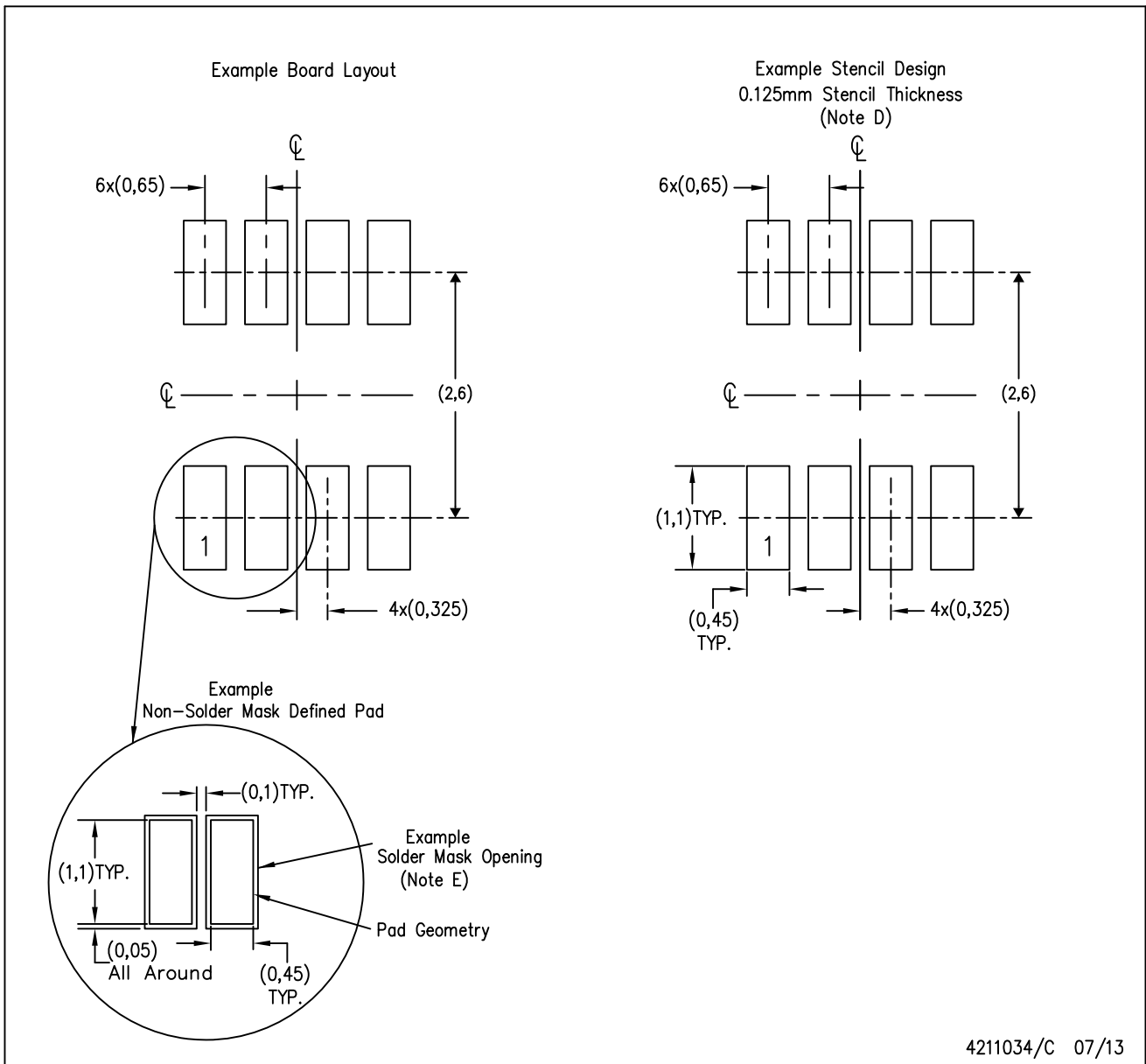

- NOTES:
- A. All linear dimensions are in millimeters.
  - B. This drawing is subject to change without notice.
  - C. Publication IPC-7351 is recommended for alternate designs.
  - D. Laser cutting apertures with trapezoidal walls and also rounding corners will offer better paste release. Customers should contact their board assembly site for stencil design recommendations. Refer to IPC-7525.
  - E. Customers should contact their board fabrication site for solder mask tolerances between and around signal pads.

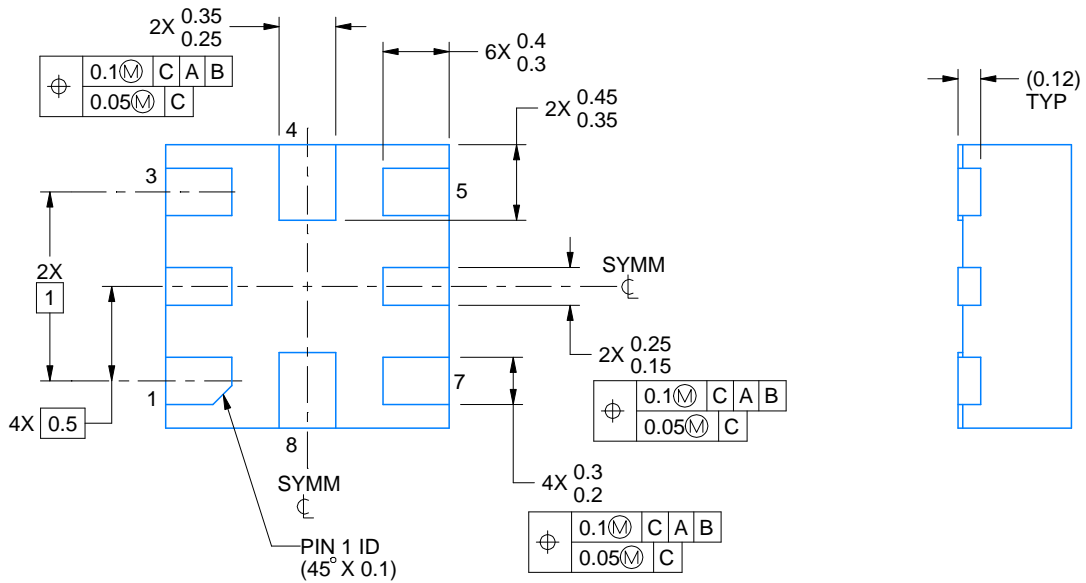
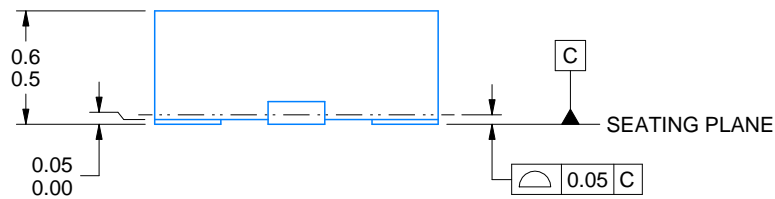
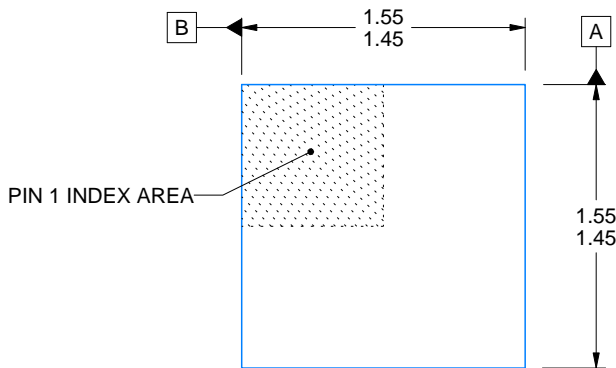
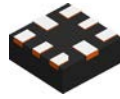

4220323/B 03/2018

NOTES:

1. All linear dimensions are in millimeters. Any dimensions in parenthesis are for reference only. Dimensioning and tolerancing per ASME Y14.5M.
2. This drawing is subject to change without notice.

# EXAMPLE BOARD LAYOUT

RSE0008A

UQFN - 0.6 mm max height

PLASTIC QUAD FLATPACK - NO LEAD

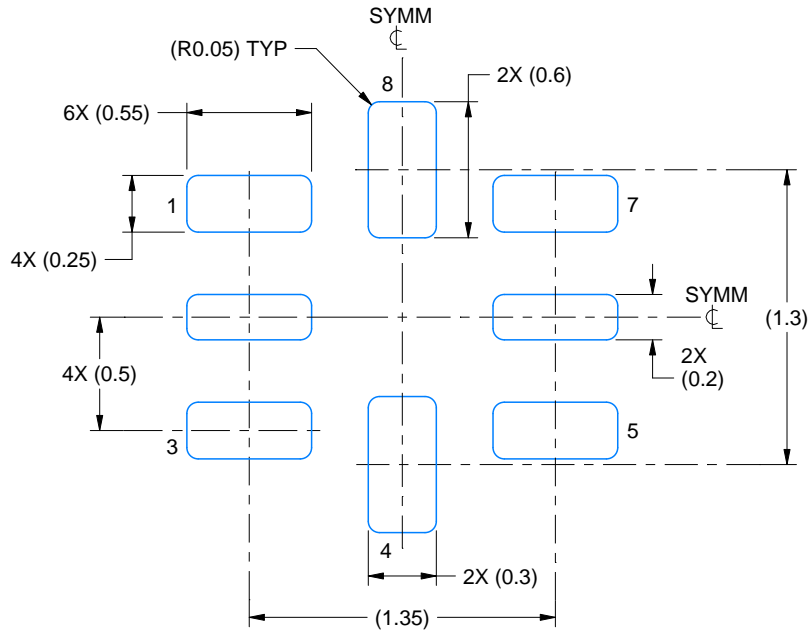

LAND PATTERN EXAMPLE  
SCALE:30X

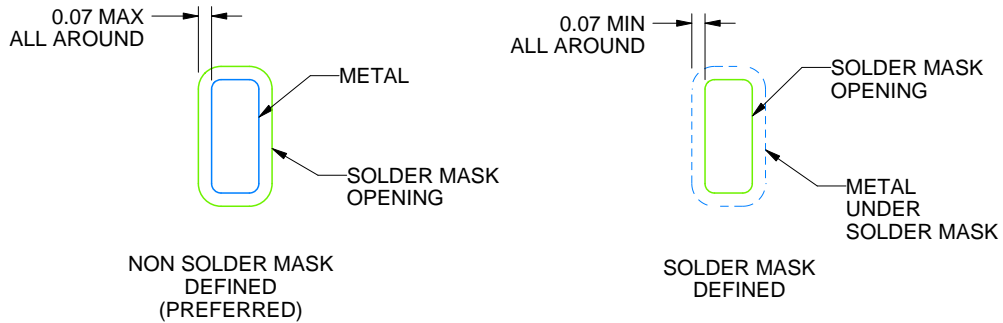

SOLDER MASK DETAILS  
NOT TO SCALE

4220323/B 03/2018

NOTES: (continued)

3. For more information, see Texas Instruments literature number SLUA271 ([www.ti.com/lit/slua271](http://www.ti.com/lit/slua271)).

# EXAMPLE STENCIL DESIGN

RSE0008A

UQFN - 0.6 mm max height

PLASTIC QUAD FLATPACK - NO LEAD

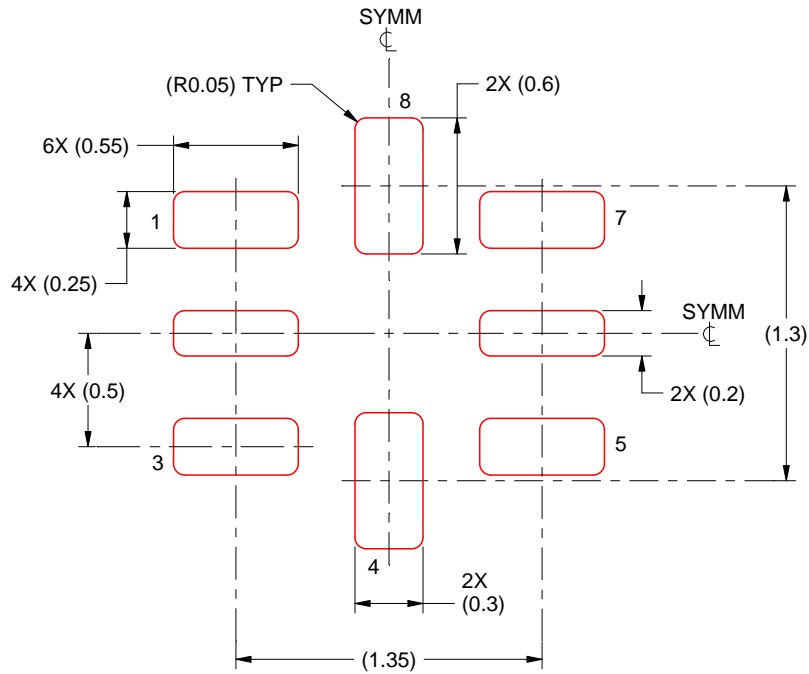

SOLDER PASTE EXAMPLE  
BASED ON 0.1 mm THICKNESS  
SCALE: 30X

4220323/B 03/2018

NOTES: (continued)

5. Laser cutting apertures with trapezoidal walls and rounded corners may offer better paste release. IPC-7525 may have alternate design recommendations.

## 重要声明和免责声明

TI 均以“原样”提供技术性 & 可靠性数据（包括数据表）、设计资源（包括参考设计）、应用或其他设计建议、网络工具、安全信息和其他资源，不保证其中不含任何瑕疵，且不做任何明示或暗示的担保，包括但不限于对适销性、适合某特定用途或不侵犯任何第三方知识产权的暗示担保。

所述资源可供专业开发人员应用 TI 产品进行设计使用。您将对以下行为独自承担全部责任：(1) 针对您的应用选择合适的 TI 产品；(2) 设计、验证并测试您的应用；(3) 确保您的应用满足相应标准以及任何其他安全、安保或其他要求。所述资源如有变更，恕不另行通知。TI 对您使用所述资源的授权仅限于开发资源所涉及 TI 产品的相关应用。除此之外不得复制或展示所述资源，也不提供其它 TI 或任何第三方的知识产权授权许可。如因使用所述资源而产生任何索赔、赔偿、成本、损失及债务等，TI 对此概不负责，并且您须赔偿由此对 TI 及其代表造成的损害。

TI 所提供产品均受 TI 的销售条款 (<http://www.ti.com.cn/zh-cn/legal/termsofsale.html>) 以及 [ti.com.cn](http://www.ti.com.cn) 上或随附 TI 产品提供的其他可适用条款的约束。TI 提供所述资源并不扩展或以其他方式更改 TI 针对 TI 产品所发布的可适用的担保范围或担保免责声明。

邮寄地址：上海市浦东新区世纪大道 1568 号中建大厦 32 楼，邮政编码：200122

Copyright © 2020 德州仪器半导体技术（上海）有限公司