

AUTOSWITCHING POWER MUX

Check for Samples: [TPS2114A](#), [TPS2115A](#)

FEATURES

- Two-Input, One-Output Power Multiplexer with Low $r_{DS(on)}$ Switches:
 - 120 m Ω Typ (TPS2114A)
 - 84 m Ω Typ (TPS2115A)
- Reverse and Cross-Conduction Blocking
- Wide Operating Voltage Range: 2.8 V to 5.5 V
- Low Standby Current: 0.5- μ A Typ
- Low Operating Current: 55- μ A Typ
- Adjustable Current Limit
- Controlled Output Voltage Transition Times
- Limit Inrush Current and Minimize Output Voltage Hold-Up Capacitance
- CMOS- and TTL-Compatible Control Inputs
- Manual and Auto-Switching Operating Modes
- Thermal Shutdown
- Available in TSSOP-8 and 3-mm \times 3-mm SON-8 Packages

APPLICATIONS

- PCs
- PDAs
- Digital Cameras
- Modems
- Cell Phones
- Digital Radios
- MP3 Players

DESCRIPTION

The TPS211xA family of power multiplexers enables seamless transition between two power supplies (such as a battery and a wall adapter), each operating at 2.8 V to 5.5 V and delivering up to 2 A, depending on package. The TPS211xA family includes extensive protection circuitry, including user-programmable current limiting, thermal protection, inrush current control, seamless supply transition, cross-conduction blocking, and reverse-conduction blocking. These features greatly simplify designing power multiplexer applications.

TYPICAL APPLICATION

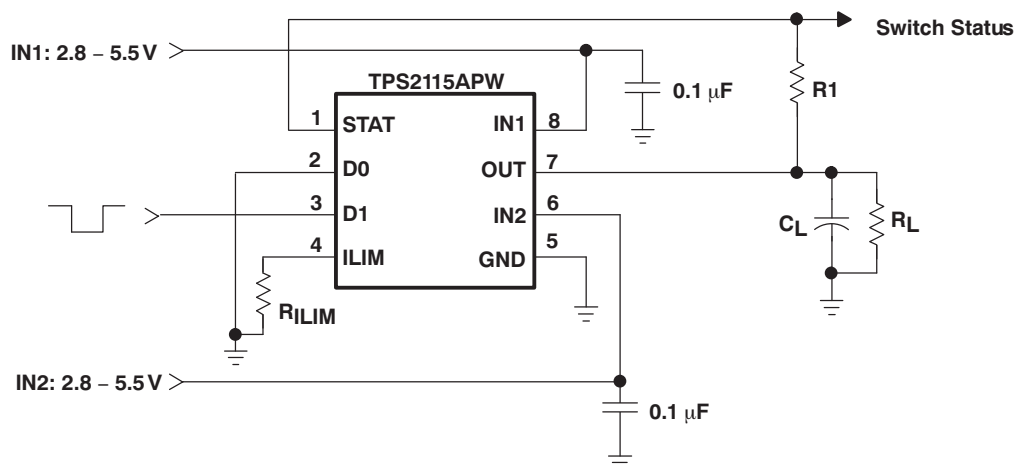

Please be aware that an important notice concerning availability, standard warranty, and use in critical applications of Texas Instruments semiconductor products and disclaimers thereto appears at the end of this data sheet.

All trademarks are the property of their respective owners.



This integrated circuit can be damaged by ESD. Texas Instruments recommends that all integrated circuits be handled with appropriate precautions. Failure to observe proper handling and installation procedures can cause damage.

ESD damage can range from subtle performance degradation to complete device failure. Precision integrated circuits may be more susceptible to damage because very small parametric changes could cause the device not to meet its published specifications.

DEVICE INFORMATION⁽¹⁾

T _A	PACKAGE	I _{OUT}	ORDERING NUMBER	MARKING
–40°C to 85°C	TSSOP-8 (PW)	0.75	TPS2114APW	2114A
		1.25	TPS2115APW	2115A
	SON-8 (DRB)	2	TPS2115ADRB	CGF

(1) For the most current package and ordering information see the Package Option Addendum at the end of this document, or visit the device product folder at www.ti.com.

ABSOLUTE MAXIMUM RATINGS⁽¹⁾

Over recommended junction temperature range (unless otherwise noted).

		VALUE		UNIT
		MIN	MAX	
Voltage	IN1, IN2, D0, D1, ILIM ⁽²⁾	–0.3	6	V
	V _{O(OUT)} , V _{O(STAT)} ⁽²⁾	–0.3	6	V
Current	Output sink, I _{O(STAT)}		5	mA
	Continuous output, I _O (TPS2114APW)		0.9	A
	Continuous output, I _O (TPS2115APW)		1.5	A
	Continuous output, I _O (TPS2115ADRB), T _J ≤ 105°C		2.5	A
Power dissipation	Continuous total	See Power Dissipation Ratings table		
Temperature	Operating virtual junction, T _J	–40	125	°C
ESD ratings	Human body model, HBM		2	kV
	Charge device model, CDM		500	V

(1) Stresses beyond those listed under *Absolute Maximum Ratings* may cause permanent damage to the device. These are stress ratings only, and functional operation of the device at these or any other conditions beyond those indicated is not implied. Exposure to absolute-maximum rated conditions for extended periods may affect device reliability.

(2) All voltages are with respect to GND.

AVAILABLE OPTIONS

FEATURE		TPS2114A	TPS2115A
Current limit adjustment range		0.31 A to 0.75 A	0.63 A to 2 A
Switching modes	Manual	Yes	Yes
	Automatic	Yes	Yes
Switch status output		Yes	Yes
Package		TSSOP-8	TSSOP-8
			SON-8

PACKAGE DISSIPATION RATINGS

PACKAGE	DERATING FACTOR ABOVE $T_A = 25^\circ\text{C}$	$T_A \leq 25^\circ\text{C}$ POWER RATING	$T_A = 70^\circ\text{C}$ POWER RATING	$T_A = 85^\circ\text{C}$ POWER RATING
TSSOP-8 (PW)	3.9 mW/°C	387 mW	213 mW	155 mW
SON-8 (DRB)	25.0 mW/°C	2.50 W	1.38 W	1.0 W

RECOMMENDED OPERATING CONDITIONS

		MIN	NOM	MAX	UNIT
Input voltage at IN1, $V_{I(IN1)}$	$V_{I(IN2)} \geq 2.8\text{ V}$	1.5		5.5	V
	$V_{I(IN2)} < 2.8\text{ V}$	2.8		5.5	V
Input voltage at IN2, $V_{I(IN2)}$	$V_{I(IN1)} \geq 2.8\text{ V}$	1.5		5.5	V
	$V_{I(IN1)} < 2.8\text{ V}$	2.8		5.5	V
Input voltage, $V_{I(DO)}$, $V_{I(D1)}$		0		5.5	V
Nominal current limit adjustment range, $I_{O(OUT)}^{(1)}$	TPS2114APW	0.31		0.75	A
	TPS2115APW	0.63		1.25	A
	TPS2115ADRB, $T_J \leq 105^\circ\text{C}$	0.63		2	A
Operating virtual junction temperature, T_J		-40		125	°C

(1) Minimum recommended current is based on accuracy considerations.

ELECTRICAL CHARACTERISTICS: POWER SWITCH

Over recommended operating junction temperature range, $V_{I(IN1)} = V_{I(IN2)} = 5.5\text{ V}$, and $R_{ILIM} = 400\ \Omega$, unless otherwise noted.

PARAMETER	TEST CONDITIONS	TPS2114A			TPS2115A			UNIT
		MIN	TYP	MAX	MIN	TYP	MAX	
$r_{DS(on)}^{(1)}$ Drain-source on-state resistance (INx-OUT)	$T_J = 25^\circ\text{C}$, $I_L = 500\text{ mA}$, $V_{I(IN1)} = V_{I(IN2)} = 5.0\text{ V}$		120	140		84	110	mΩ
	$T_J = 25^\circ\text{C}$, $I_L = 500\text{ mA}$, $V_{I(IN1)} = V_{I(IN2)} = 3.3\text{ V}$		120	140		84	110	mΩ
	$T_J = 25^\circ\text{C}$, $I_L = 500\text{ mA}$, $V_{I(IN1)} = V_{I(IN2)} = 2.8\text{ V}$		120	140		84	110	mΩ
	$T_J = 125^\circ\text{C}$, $I_L = 500\text{ mA}$, $V_{I(IN1)} = V_{I(IN2)} = 5.0\text{ V}$			220			150	mΩ
	$T_J = 125^\circ\text{C}$, $I_L = 500\text{ mA}$, $V_{I(IN1)} = V_{I(IN2)} = 3.3\text{ V}$			220			150	mΩ
	$T_J = 125^\circ\text{C}$, $I_L = 500\text{ mA}$, $V_{I(IN1)} = V_{I(IN2)} = 2.8\text{ V}$			220			150	mΩ

(1) The TPS211xA can switch a voltage as low as 1.5 V as long as there is a minimum of 2.8 V at one of the input power pins. In this specific case, the lower supply voltage has no effect on the IN1 and IN2 switch on-resistances.

ELECTRICAL CHARACTERISTICS: GENERAL

Over recommended operating junction temperature range, $V_{I(IN1)} = V_{I(IN2)} = 5.5\text{ V}$, and $R_{ILIM} = 400\ \Omega$, unless otherwise noted.

PARAMETER	TEST CONDITIONS	TPS2114A			UNIT
		MIN	TYP	MAX	
LOGIC INPUTS (D0 AND D1)					
V_{IH}	High-level input voltage	2			V
V_{IL}	Low-level input voltage				0.7
Input current at D0 or D1	D0 or D1 = high, sink current				1
	D0 or D1 = low, source current	0.5	1.4	5	μA
SUPPLY AND LEAKAGE CURRENTS					
Supply current from IN1 (operating)	D1 = high, D0 = low (IN1 active), $V_{I(IN1)} = 5.5\text{ V}$, $V_{I(IN2)} = 3.3\text{ V}$, $I_{O(OUT)} = 0\text{ A}$	55			90
	D1 = high, D0 = low (IN1 active), $V_{I(IN1)} = 3.3\text{ V}$, $V_{I(IN2)} = 5.5\text{ V}$, $I_{O(OUT)} = 0\text{ A}$	1			12
	D0 = D1 = low (IN2 active), $V_{I(IN1)} = 5.5\text{ V}$, $V_{I(IN2)} = 3.3\text{ V}$, $I_{O(OUT)} = 0\text{ A}$				75
	D0 = D1 = low (IN2 active), $V_{I(IN1)} = 3.3\text{ V}$, $V_{I(IN2)} = 5.5\text{ V}$, $I_{O(OUT)} = 0\text{ A}$				1
Supply current from IN2 (operating)	D1 = high, D0 = low (IN1 active), $V_{I(IN1)} = 5.5\text{ V}$, $V_{I(IN2)} = 3.3\text{ V}$, $I_{O(OUT)} = 0\text{ A}$				1
	D1 = high, D0 = low (IN1 active), $V_{I(IN1)} = 3.3\text{ V}$, $V_{I(IN2)} = 5.5\text{ V}$, $I_{O(OUT)} = 0\text{ A}$				75
	D0 = D1 = low (IN2 active), $V_{I(IN1)} = 5.5\text{ V}$, $V_{I(IN2)} = 3.3\text{ V}$, $I_{O(OUT)} = 0\text{ A}$	1			12
	D0 = D1 = low (IN2 active), $V_{I(IN1)} = 3.3\text{ V}$, $V_{I(IN2)} = 5.5\text{ V}$, $I_{O(OUT)} = 0\text{ A}$	55			90
Quiescent current from IN1 (STANDBY)	D0 = D1 = high (inactive), $V_{I(IN1)} = 5.5\text{ V}$, $V_{I(IN2)} = 3.3\text{ V}$, $I_{O(OUT)} = 0\text{ A}$	0.5			2
	D0 = D1 = high (inactive), $V_{I(IN1)} = 3.3\text{ V}$, $V_{I(IN2)} = 5.5\text{ V}$, $I_{O(OUT)} = 0\text{ A}$				1
Quiescent current from IN2 (STANDBY)	D0 = D1 = high (inactive), $V_{I(IN1)} = 5.5\text{ V}$, $V_{I(IN2)} = 3.3\text{ V}$, $I_{O(OUT)} = 0\text{ A}$				1
	D0 = D1 = high (inactive), $V_{I(IN1)} = 3.3\text{ V}$, $V_{I(IN2)} = 5.5\text{ V}$, $I_{O(OUT)} = 0\text{ A}$	0.5			2
Forward leakage current from IN1 (measured from OUT to GND)	D0 = D1 = high (inactive), $V_{I(IN1)} = 5.5\text{ V}$, IN2 open, $V_{O(OUT)} = 0\text{ V}$ (shorted), $T_J = 25^\circ\text{C}$	0.1			5
Forward leakage current from IN2 (measured from OUT to GND)	D0 = D1 = high (inactive), $V_{I(IN2)} = 5.5\text{ V}$, IN1 open, $V_{O(OUT)} = 0\text{ V}$ (shorted), $T_J = 25^\circ\text{C}$	0.1			5
Reverse leakage current to INx (measured from INx to GND)	D0 = D1 = high (inactive), $V_{I(INx)} = 0\text{ V}$, $V_{O(OUT)} = 5.5\text{ V}$, $T_J = 25^\circ\text{C}$	0.3			5
CURRENT LIMIT CIRCUIT					
Current limit accuracy, TPS2114A	$R_{ILIM} = 400\ \Omega$	0.51	0.63	0.80	A
	$R_{ILIM} = 700\ \Omega$	0.30	0.36	0.50	A
Current limit accuracy, TPS2115A	$R_{ILIM} = 400\ \Omega$	0.95	1.25	1.56	A
	$R_{ILIM} = 700\ \Omega$	0.47	0.71	0.99	A
t_d	Current limit settling time	Time for short-circuit output current to settle within 10% of its steady state value.			1
	Input current at ILIM	$V_{I(ILIM)} = 0\text{ V}$, $I_{O(OUT)} = 0\text{ A}$			-15
UVLO					
IN1 and IN2 UVLO	Falling edge	1.15	1.25		V
	Rising edge		1.30	1.35	V
IN1 and IN2 UVLO hysteresis		30	57	65	mV
Internal V_{DD} UVLO (the higher of IN1 and IN2)	Falling edge	2.4	2.53		V
	Rising edge		2.58	2.8	V
Internal V_{DD} UVLO hysteresis		30	50	75	mV
UVLO deglitch for IN1, IN2	Falling edge				110

ELECTRICAL CHARACTERISTICS: GENERAL (continued)

Over recommended operating junction temperature range, $V_{I(IN1)} = V_{I(IN2)} = 5.5\text{ V}$, and $R_{ILIM} = 400\ \Omega$, unless otherwise noted.

PARAMETER	TEST CONDITIONS	TPS2114A			UNIT	
		MIN	TYP	MAX		
REVERSE CONDUCTION BLOCKING						
$\Delta V_{O(I_block)}$	Minimum input-to-output voltage difference to block switching D0 = D1 = high, $V_{I(INx)} = 3.3\text{ V}$ Connect OUT to a 5-V supply through a series 1-k Ω resistor. Let D0 = low. Slowly decrease the supply voltage until OUT connects to IN1.	80	100	120	mV	
THERMAL SHUTDOWN						
Thermal shutdown threshold	TPS211xA is in current limit	135			$^{\circ}\text{C}$	
Recovery from thermal shutdown	TPS211xA is in current limit	125			$^{\circ}\text{C}$	
Hysteresis		10			$^{\circ}\text{C}$	
IN2-IN1 COMPARATORS						
Hysteresis of IN2-IN1 comparator		0.1			0.2	V
Deglitch of IN2-IN1 comparator (both $\uparrow\downarrow$)		10	20	50	μs	
STAT OUTPUT						
Leakage current	$V_{O(STAT)} = 5.5\text{ V}$	0.01			1	μA
Saturation voltage	$I_{I(STAT)} = 2\text{ mA}$, IN1 switch is on	0.13			0.4	V
Deglitch time (falling edge only)		150			μs	

SWITCHING CHARACTERISTICS

Over recommended operating junction temperature range, $V_{I(IN1)} = V_{I(IN2)} = 5.5\text{ V}$, and $R_{ILIM} = 400\ \Omega$, unless otherwise noted.

PARAMETER	TEST CONDITIONS	TPS2114A			TPS2115A			UNIT
		MIN	TYP	MAX	MIN	TYP	MAX	
POWER SWITCH								
t_r	Output rise time from an enable $V_{I(IN1)} = V_{I(IN2)} = 5\text{ V}$, $T_J = 25^{\circ}\text{C}$, $C_L = 1\ \mu\text{F}$, $I_L = 500\text{ mA}$ (see Figure 1a)	0.5	1.0	1.5	1	1.8	3	ms
t_f	Output fall time from a disable $V_{I(IN1)} = V_{I(IN2)} = 5\text{ V}$, $T_J = 25^{\circ}\text{C}$, $C_L = 1\ \mu\text{F}$, $I_L = 500\text{ mA}$ (see Figure 1a)	0.35	0.5	0.7	0.5	1	2	ms
t_t	IN1 to IN2 transition, $V_{I(IN1)} = 3.3\text{ V}$, $V_{I(IN2)} = 5\text{ V}$, $T_J = 125^{\circ}\text{C}$, $C_L = 10\ \mu\text{F}$, $I_L = 500\text{ mA}$ Measure transition time as 10–90% rise time or from 3.4 V to 4.8 V on $V_{O(OUT)}$ (see Figure 1b).	40			60			μs
	IN2 to IN1 transition, $V_{I(IN1)} = 5\text{ V}$, $V_{I(IN2)} = 3.3\text{ V}$, $T_J = 125^{\circ}\text{C}$, $C_L = 10\ \mu\text{F}$, $I_L = 500\text{ mA}$ Measure transition time as 10–90% rise time or from 3.4 V to 4.8 V on $V_{O(OUT)}$ (see Figure 1b).	40			60			μs
t_{PLH1}	Turn-on propagation delay from enable $V_{I(IN1)} = V_{I(IN2)} = 5\text{ V}$, measured from enable to 10% of $V_{O(OUT)}$, $T_J = 25^{\circ}\text{C}$, $C_L = 10\ \mu\text{F}$, $I_L = 500\text{ mA}$ (see Figure 1a)	0.5			1			ms
t_{PHL1}	Turn-off propagation delay from a disable $V_{I(IN1)} = V_{I(IN2)} = 5\text{ V}$, measured from disable to 90% of $V_{O(OUT)}$, $T_J = 25^{\circ}\text{C}$, $C_L = 10\ \mu\text{F}$, $I_L = 500\text{ mA}$ (see Figure 1a)	3			5			ms
t_{PLH2}	Switch-over rising propagation delay Logic 1 to Logic 0 transition on D1, $V_{I(IN1)} = 1.5\text{ V}$, $V_{I(IN2)} = 5\text{ V}$, $V_{I(D0)} = 0\text{ V}$, measured from D1 to 10% of $V_{O(OUT)}$, $T_J = 25^{\circ}\text{C}$, $C_L = 10\ \mu\text{F}$, $I_L = 500\text{ mA}$ (see Figure 1c)	40			100			μs
t_{PHL2}	Switch-over falling propagation delay Logic 0 to Logic 1 transition on D1, $V_{I(IN1)} = 1.5\text{ V}$, $V_{I(IN2)} = 5\text{ V}$, $V_{I(D0)} = 0\text{ V}$, measured from D1 to 90% of $V_{O(OUT)}$, $T_J = 25^{\circ}\text{C}$, $C_L = 10\ \mu\text{F}$, $I_L = 500\text{ mA}$ (see Figure 1c)	2	3	10	2	5	10	ms

Table 1. Truth Table

D1	D0	$V_{I(IN2)} > V_{I(IN1)}$	STAT	OUT ⁽¹⁾
0	0	X ⁽²⁾	Hi-Z	IN2
0	1	No	0	IN1
0	1	Yes	Hi-Z	IN2
1	0	X	0	IN1
1	1	X	0	Hi-Z

- (1) The under-voltage lockout circuit causes the output OUT to go Hi-Z if the selected power supply does not exceed the IN1/IN2 UVLO, or if neither of the supplies exceeds the internal V_{DD} UVLO.
 (2) X = Don't care.

PIN CONFIGURATIONS

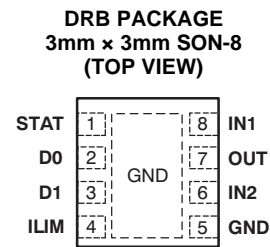
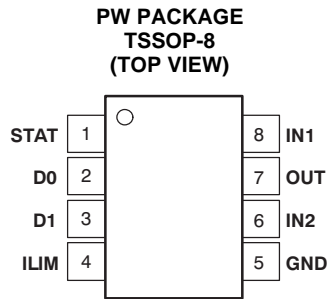

TERMINAL FUNCTIONS

TERMINAL		I/O	DESCRIPTION
NAME	NO.		
D0	2	I	TTL- and CMOS-compatible input pins. Each pin has a 1- μ A pull-up. Table 1 illustrates the functionality of D0 and D1.
D1	3	I	TTL- and CMOS-compatible input pins. Each pin has a 1- μ A pull-up. Table 1 illustrates the functionality of D0 and D1.
GND	5	I	Ground
IN1	8	I	Primary power switch input. The IN1 switch can be enabled only if the IN1 supply is above the UVLO threshold and at least one supply exceeds the internal V_{DD} UVLO.
IN2	6	I	Secondary power switch input. The IN2 switch can be enabled only if the IN2 supply is above the UVLO threshold and at least one supply exceeds the internal V_{DD} UVLO.
ILIM	4	I	A resistor R_{ILIM} from ILIM to GND sets the current limit I_L to $250/R_{ILIM}$ and $500/R_{ILIM}$ for the TPS2114A and TPS2115A, respectively.
OUT	7	O	Power switch output
STAT	1	O	STAT is an open-drain output that is Hi-Z if the IN2 switch is ON. STAT pulls low if the IN1 switch is ON or if OUT is Hi-Z (i.e., \overline{EN} is equal to logic 0).
PAD	—	I	Tie to GND. Connect to internal planes for improved heatsinking with multiple vias.

FUNCTIONAL BLOCK DIAGRAM

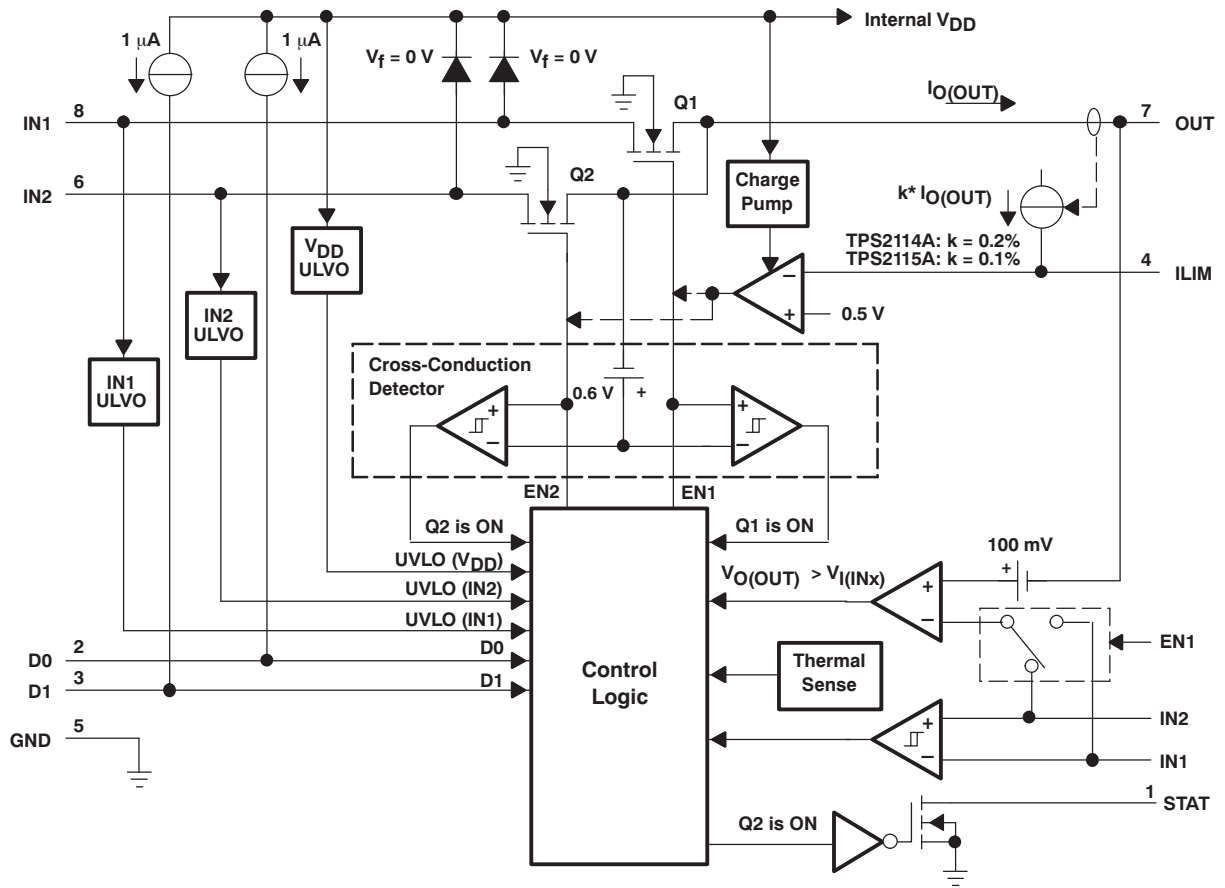

PARAMETER MEASUREMENT INFORMATION

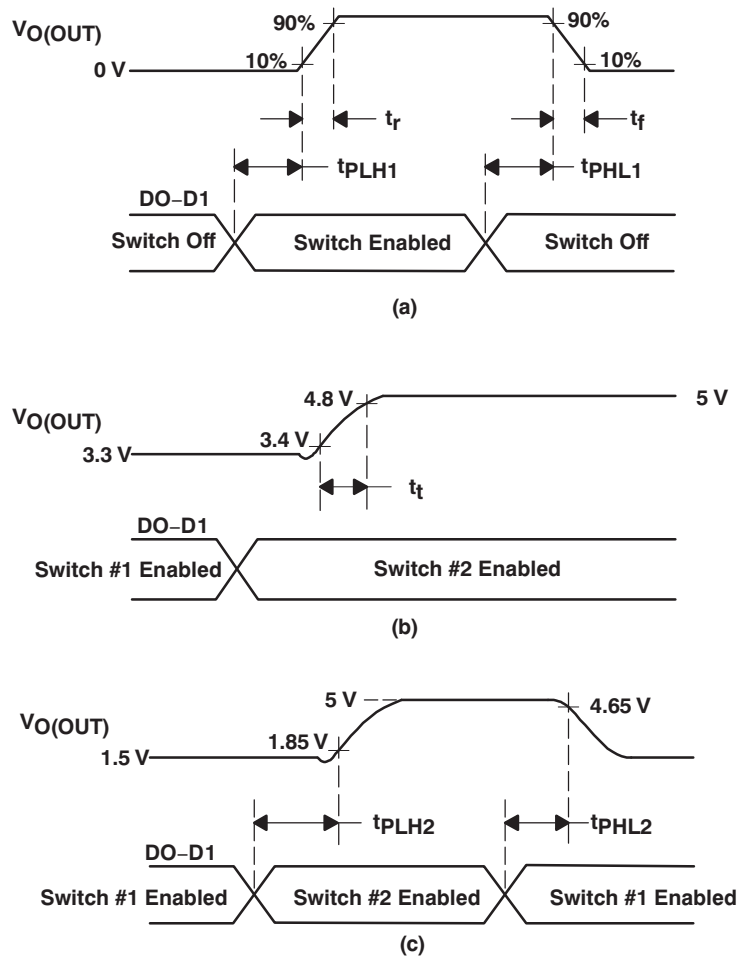
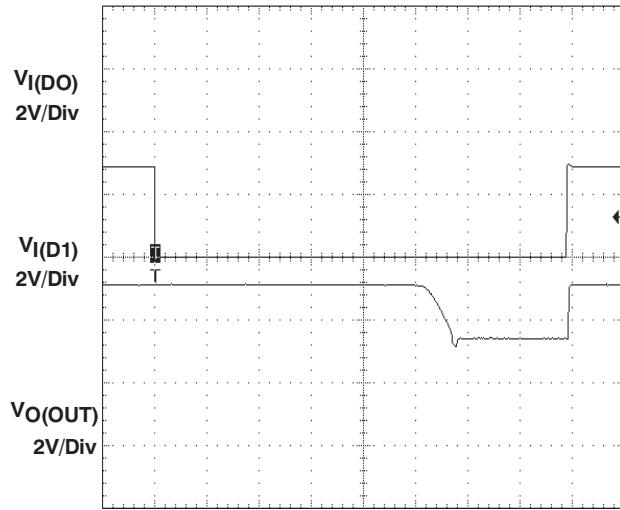

Figure 1. Propagation Delays and Transition Timing Waveforms

TYPICAL CHARACTERISTICS

OUTPUT SWITCHOVER RESPONSE



t – Time – 1 ms/div

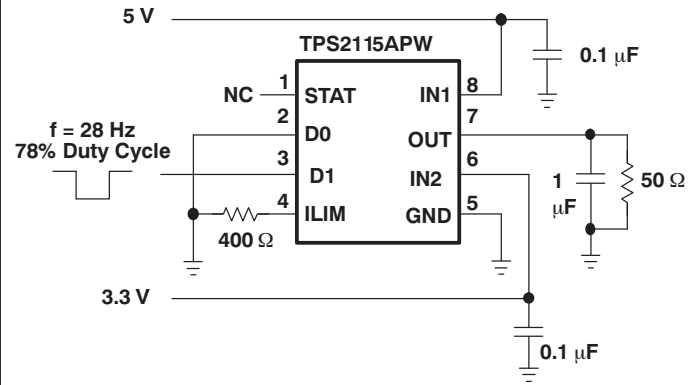

Output Switchover Response Test Circuit

Figure 2.

OUTPUT TURN-ON RESPONSE

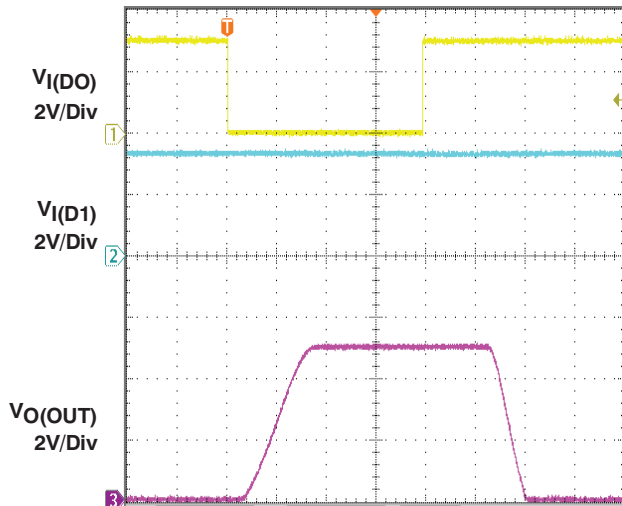

t – Time – 2 ms/div

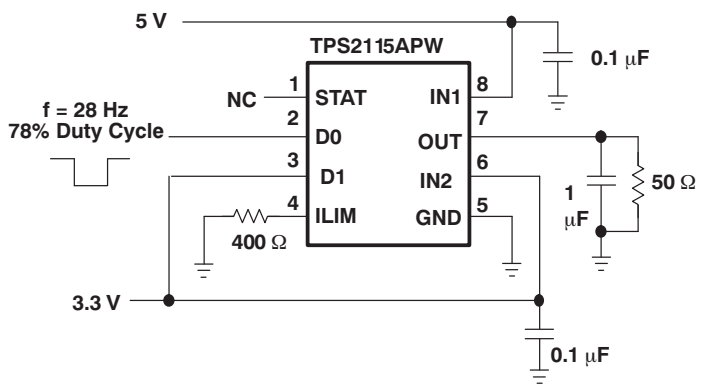

Output Turn-On Response Test Circuit

Figure 3.

TYPICAL CHARACTERISTICS (continued)

OUTPUT SWITCHOVER VOLTAGE DROOP

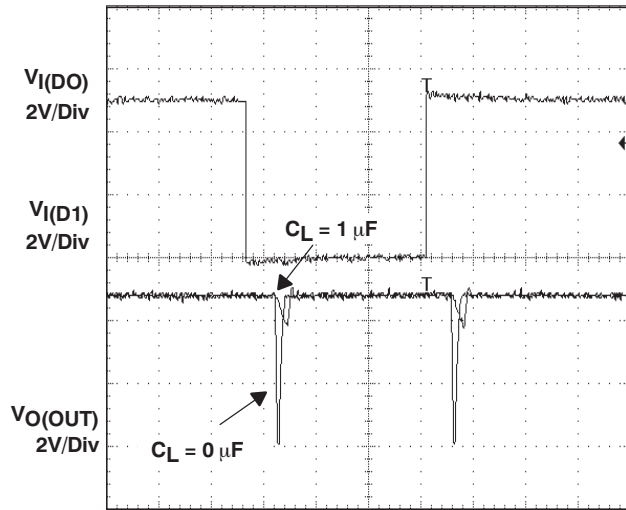

t – Time – 40 μs/div

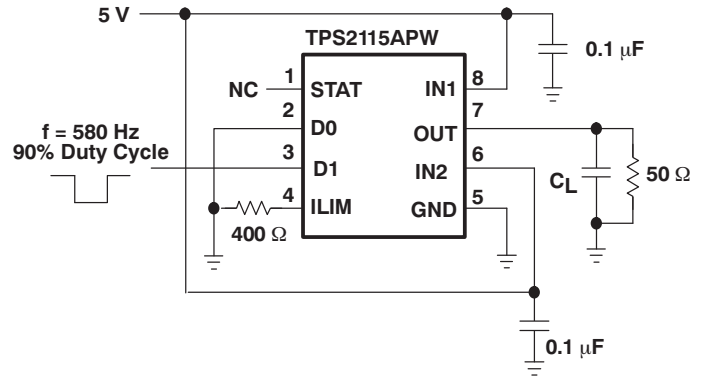

Output Switchover Voltage Droop Test Circuit

Figure 4.

TYPICAL CHARACTERISTICS (continued)

OUTPUT SWITCHOVER VOLTAGE DROOP
VS
LOAD CAPACITANCE

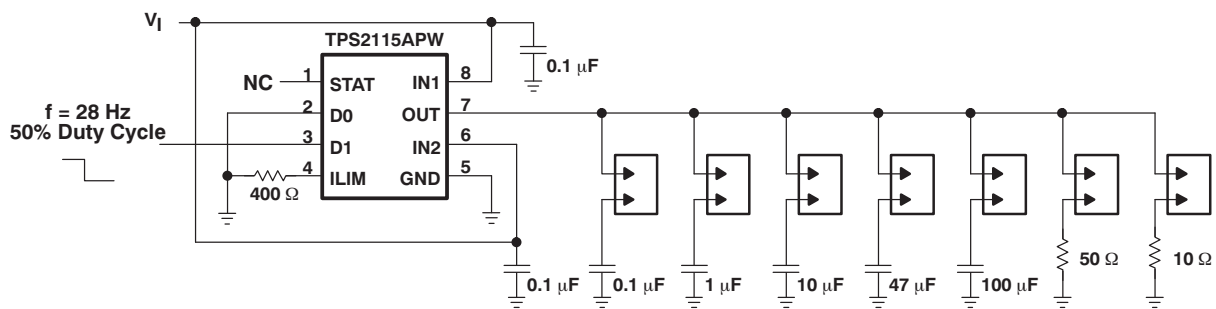
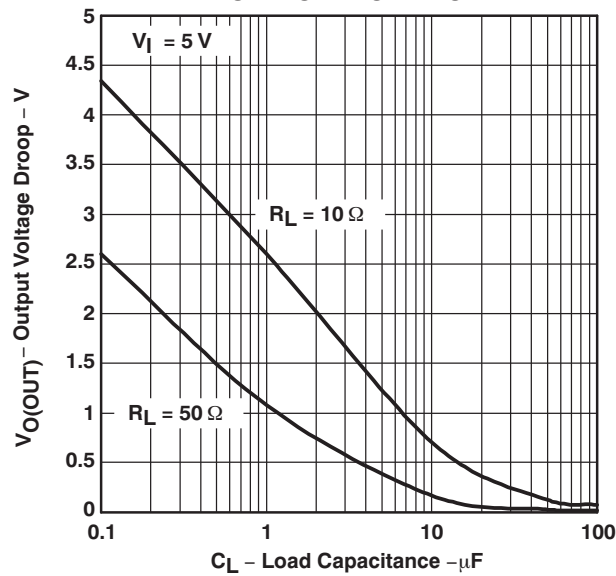

Output Switchover Voltage Droop Test Circuit

Figure 5.

TYPICAL CHARACTERISTICS (continued)

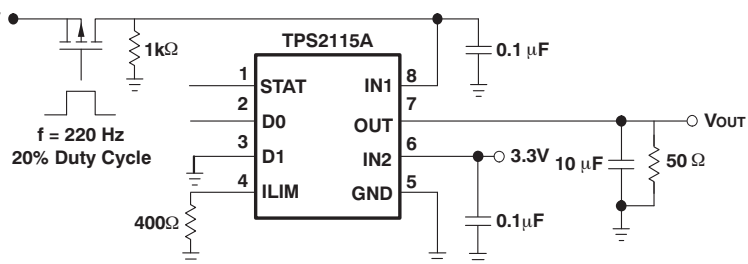
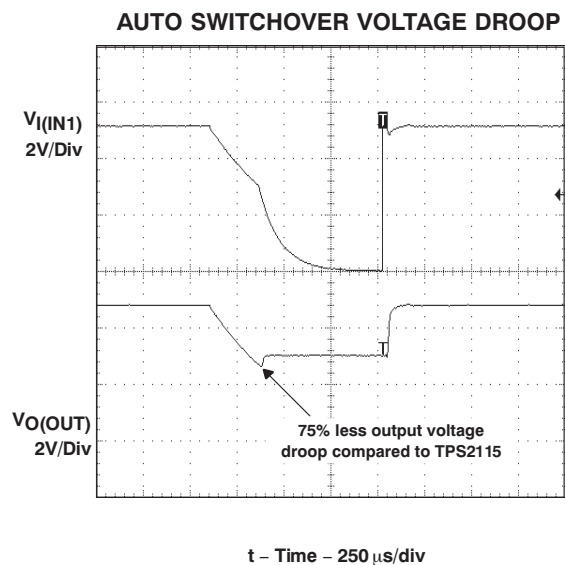

Auto Switchover Voltage Droop Test Circuit

Figure 6.

TYPICAL CHARACTERISTICS (continued)

INRUSH CURRENT
VS
LOAD CAPACITANCE

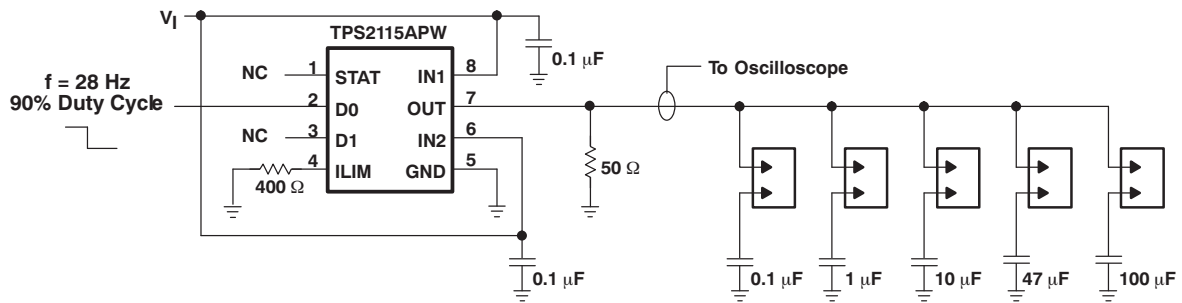
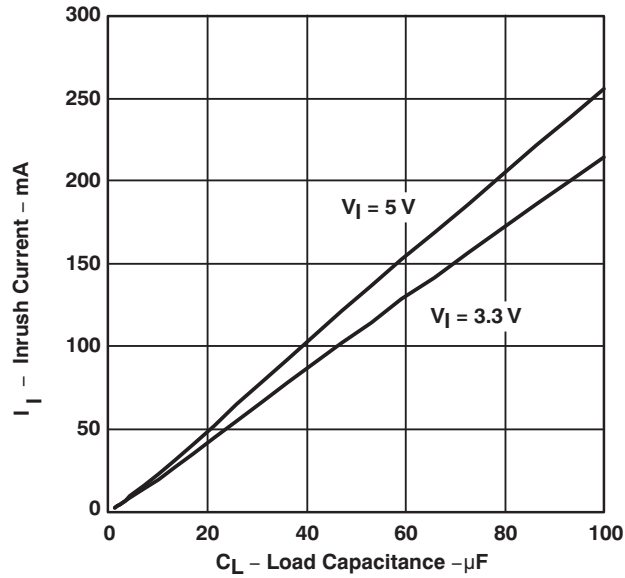

Output Capacitor Inrush Current Test Circuit

Figure 7.

TYPICAL CHARACTERISTICS (continued)

SWITCH ON-RESISTANCE
vs
JUNCTION TEMPERATURE

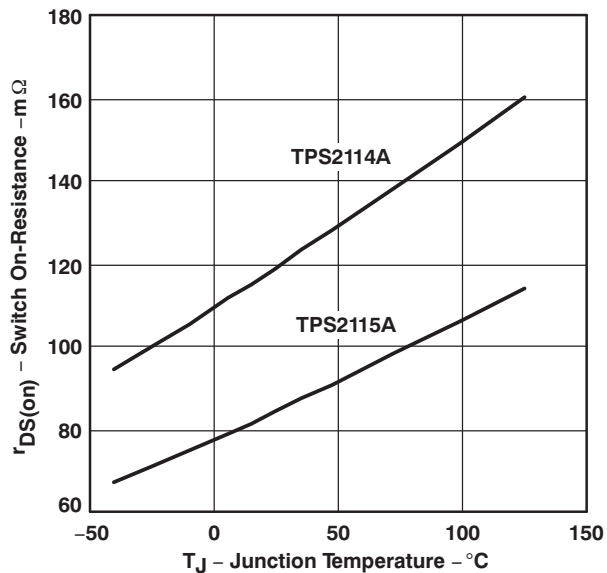

Figure 8.

SWITCH ON-RESISTANCE
vs
SUPPLY VOLTAGE

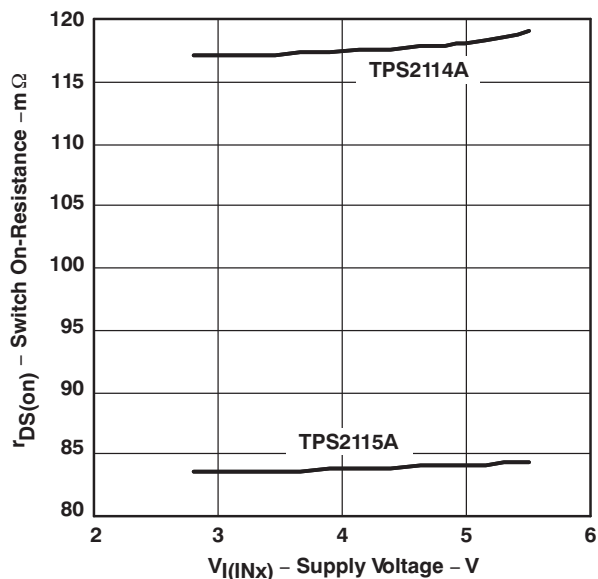

Figure 9.

IN1 SUPPLY CURRENT
vs
SUPPLY VOLTAGE

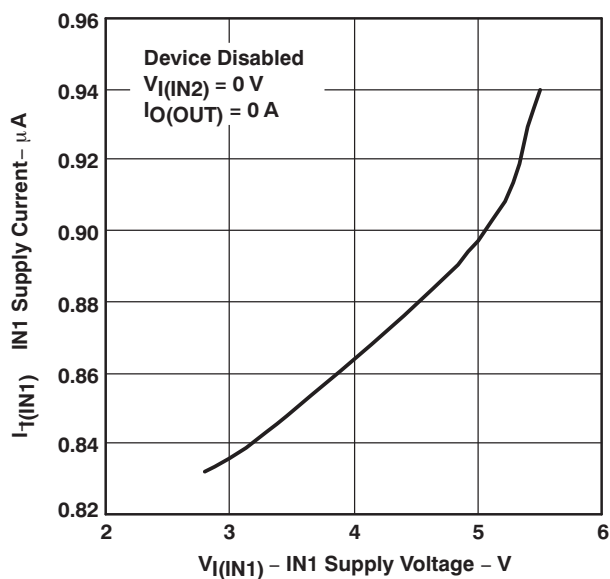

Figure 10.

IN1 SUPPLY CURRENT
vs
SUPPLY VOLTAGE

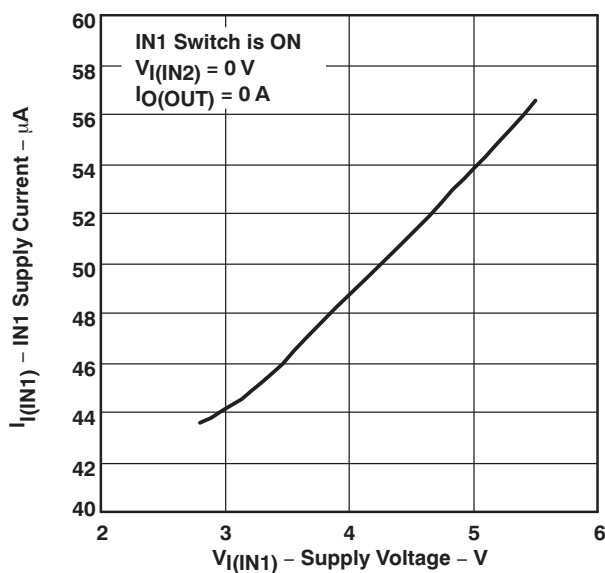

Figure 11.

TYPICAL CHARACTERISTICS (continued)

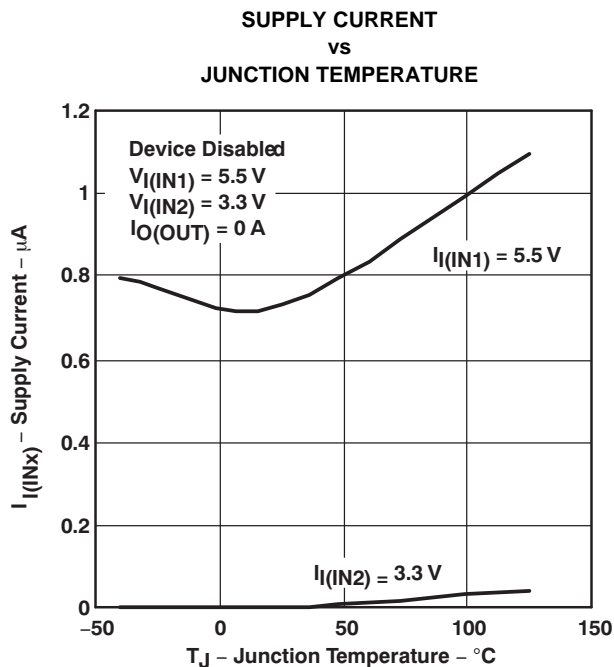

Figure 12.

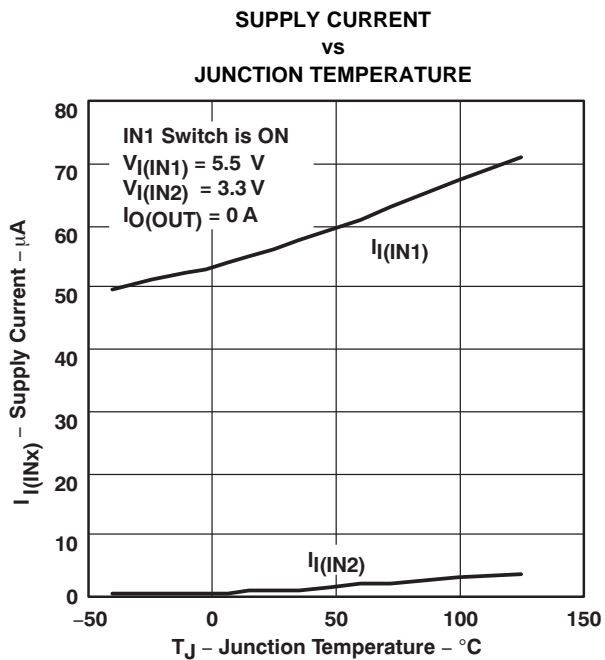

Figure 13.

APPLICATION INFORMATION

Some applications have two energy sources, one of which should be used in preference to another. Figure 14 shows a circuit that will connect IN1 to OUT until the voltage at IN1 falls below a user-specified value. Once the voltage on IN1 falls below this value, the TPS2114A/5A will select the higher of the two supplies. This usually means that the TPS2114A/5A will swap to IN2.

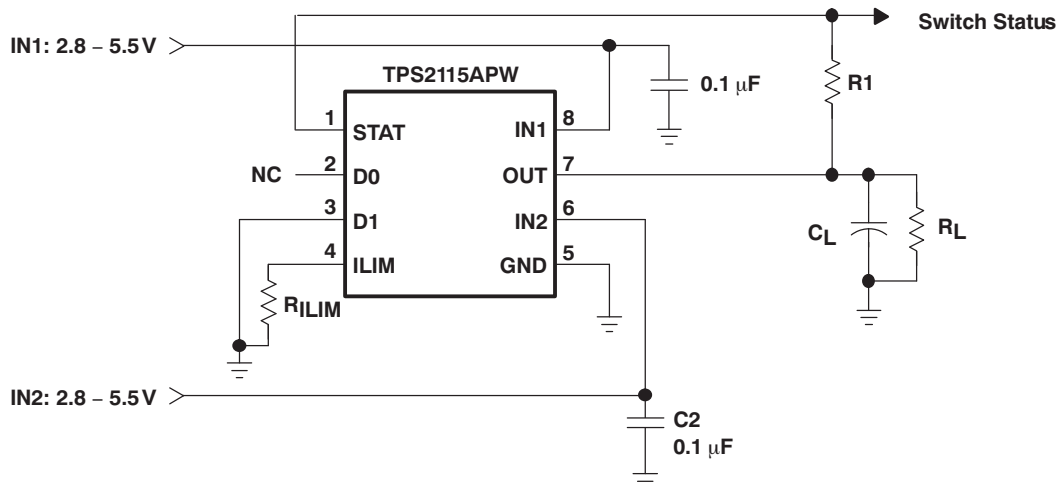

Figure 14. Auto-Selecting for a Dual Power Supply Application

In Figure 15, the multiplexer selects between two power supplies based upon the D1 logic signal. OUT connects to IN1 if D1 is logic 1; otherwise, OUT connects to IN2. The logic thresholds for the D1 terminal are compatible with both TTL and CMOS logic.

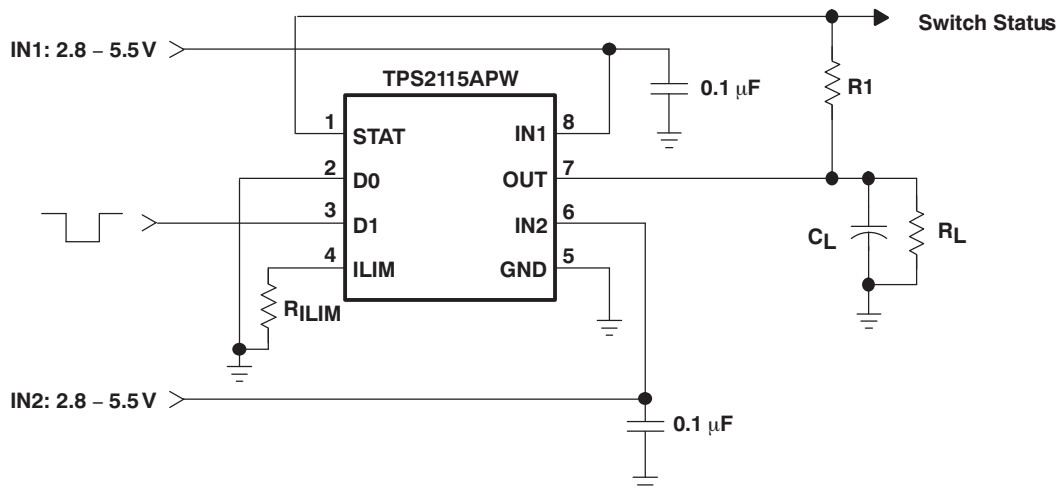

Figure 15. Manually Switching Power Sources

DETAILED DESCRIPTION

AUTO-SWITCHING MODE

D0 equal to logic 1 and D1 equal to logic 0 selects the auto-switching mode. In this mode, OUT connects to the higher of IN1 and IN2.

MANUAL SWITCHING MODE

D0 equal to logic 0 selects the manual-switching mode. In this mode, OUT connects to IN1 if D1 is equal to logic 1, otherwise OUT connects to IN2.

N-CHANNEL MOSFETs

Two internal high-side power MOSFETs implement a single-pole double-throw (SPDT) switch. Digital logic selects the IN1 switch, IN2 switch, or no switch (Hi-Z state). The MOSFETs have no parallel diodes so output-to-input current cannot flow when the FET is off. An integrated comparator prevents turn-on of a FET switch if the output voltage is greater than the input voltage.

CROSS-CONDUCTION BLOCKING

The switching circuitry ensures that both power switches will never conduct at the same time. A comparator monitors the gate-to-source voltage of each power FET and allows a FET to turn on only if the gate-to-source voltage of the other FET is below the turn-on threshold voltage.

REVERSE-CONDUCTION BLOCKING

When the TPS211xA switches from a higher-voltage supply to a lower-voltage supply, current can potentially flow back from the load capacitor into the lower-voltage supply. To minimize such reverse conduction, the TPS211xA will not connect a supply to the output until the output voltage has fallen to within 100 mV of the supply voltage. Once a supply has been connected to the output, it will remain connected regardless of output voltage.

CHARGE PUMP

The higher of supplies IN1 and IN2 powers the internal charge pump. The charge pump provides power to the current limit amplifier and allows the output FET gate voltage to be higher than the IN1 and IN2 supply voltages. A gate voltage that is higher than the source voltage is necessary to turn on the N-channel FET.

CURRENT LIMITING

A resistor R_{ILIM} from ILIM to GND sets the current limit to $250/R_{ILIM}$ and $500/R_{ILIM}$ for the TPS2114A and TPS2115A, respectively. Setting resistor R_{ILIM} equal to zero is not recommended as that disables current limiting.

OUTPUT VOLTAGE SLEW-RATE CONTROL

The TPS2114A/5A slews the output voltage at a slow rate when OUT switches to IN1 or IN2 from the Hi-Z state (see [Table 1](#)). A slow slew rate limits the inrush current into the load capacitor. High inrush currents can glitch the voltage bus and cause a system to hang up or reset. It can also cause reliability issues—like pit the connector power contacts, when hot-plugging a load such as a PCI card. The TPS2114A/5A slews the output voltage at a much faster rate when OUT switches between IN1 and IN2. The fast rate minimizes the output voltage droop and reduces the output voltage hold-up capacitance requirement.

TAPE AND REEL INFORMATION

QUADRANT ASSIGNMENTS FOR PIN 1 ORIENTATION IN TAPE

*All dimensions are nominal

Device	Package Type	Package Drawing	Pins	SPQ	Reel Diameter (mm)	Reel Width W1 (mm)	A0 (mm)	B0 (mm)	K0 (mm)	P1 (mm)	W (mm)	Pin1 Quadrant
TPS2114APWR	TSSOP	PW	8	2000	330.0	12.4	7.0	3.6	1.6	8.0	12.0	Q1
TPS2115ADRBR	SON	DRB	8	3000	330.0	12.4	3.3	3.3	1.1	8.0	12.0	Q2
TPS2115ADRBT	SON	DRB	8	250	180.0	12.4	3.3	3.3	1.1	8.0	12.0	Q2
TPS2115APWR	TSSOP	PW	8	2000	330.0	12.4	7.0	3.6	1.6	8.0	12.0	Q1

TAPE AND REEL BOX DIMENSIONS

*All dimensions are nominal

Device	Package Type	Package Drawing	Pins	SPQ	Length (mm)	Width (mm)	Height (mm)
TPS2114APWR	TSSOP	PW	8	2000	367.0	367.0	35.0
TPS2115ADRBR	SON	DRB	8	3000	367.0	367.0	35.0
TPS2115ADRBT	SON	DRB	8	250	210.0	185.0	35.0
TPS2115APWR	TSSOP	PW	8	2000	367.0	367.0	35.0

REVISION HISTORY

NOTE: Page numbers for previous revisions may differ from page numbers in the current version.

Changes from Revision E (April 2011) to Revision F	Page
• Changed description of power supplies in <i>Description</i> section	1
• Added I _{OUT} column to Device Information table	2
• Changed conditions of Absolute Maximum Ratings table	2
• Added PW to end of device name in first two continuous output rows in <i>Current</i> parameter of Absolute Maximum Ratings table	2
• Added last continuous output row to <i>Current</i> parameter in Absolute Maximum Ratings table	2
• Deleted storage temperature row from Absolute Maximum Ratings table	2
• Changed <i>Current limit adjustment range</i> parameter, TPS2115A specification in Available Options table	2
• Changed Nominal current limit adjustment range parameter in Recommended Operating Conditions table	3
• Added footnote 1 to Recommended Operating Conditions table	3

Changes from Revision D (July 2006) to Revision E	Page
• Updated document to current format	1
• Changed title, footnote, and CGF marking in Device Information table	2
• Deleted footnote 1 (not tested in production) from Electrical Characteristics: General table	4
• Deleted footnote 1 (not tested in production) from Switching Characteristics table	5
• Added PAD row to Terminal Functions table	6

PACKAGING INFORMATION

Orderable Device	Status (1)	Package Type	Package Drawing	Pins	Package Qty	Eco Plan (2)	Lead finish/ Ball material (6)	MSL Peak Temp (3)	Op Temp (°C)	Device Marking (4/5)	Samples
TPS2114APW	ACTIVE	TSSOP	PW	8	150	RoHS & Green	NIPDAU	Level-1-260C-UNLIM	-40 to 85	2114A	Samples
TPS2114APWR	ACTIVE	TSSOP	PW	8	2000	RoHS & Green	NIPDAU	Level-1-260C-UNLIM	-40 to 85	2114A	Samples
TPS2115ADRBR	ACTIVE	SON	DRB	8	3000	RoHS & Green	NIPDAU	Level-2-260C-1 YEAR	-40 to 85	CGF	Samples
TPS2115ADRBT	ACTIVE	SON	DRB	8	250	RoHS & Green	NIPDAU	Level-2-260C-1 YEAR	-40 to 85	CGF	Samples
TPS2115ADRBTG4	ACTIVE	SON	DRB	8	250	RoHS & Green	NIPDAU	Level-2-260C-1 YEAR	-40 to 85	CGF	Samples
TPS2115APW	ACTIVE	TSSOP	PW	8	150	RoHS & Green	NIPDAU	Level-1-260C-UNLIM	-40 to 85	2115A	Samples
TPS2115APWR	ACTIVE	TSSOP	PW	8	2000	RoHS & Green	NIPDAU	Level-1-260C-UNLIM	-40 to 85	2115A	Samples
TPS2115APWRG4	ACTIVE	TSSOP	PW	8	2000	RoHS & Green	NIPDAU	Level-1-260C-UNLIM	-40 to 85	2115A	Samples

(1) The marketing status values are defined as follows:

ACTIVE: Product device recommended for new designs.

LIFEBUY: TI has announced that the device will be discontinued, and a lifetime-buy period is in effect.

NRND: Not recommended for new designs. Device is in production to support existing customers, but TI does not recommend using this part in a new design.

PREVIEW: Device has been announced but is not in production. Samples may or may not be available.

OBSOLETE: TI has discontinued the production of the device.

(2) **RoHS:** TI defines "RoHS" to mean semiconductor products that are compliant with the current EU RoHS requirements for all 10 RoHS substances, including the requirement that RoHS substance do not exceed 0.1% by weight in homogeneous materials. Where designed to be soldered at high temperatures, "RoHS" products are suitable for use in specified lead-free processes. TI may reference these types of products as "Pb-Free".

RoHS Exempt: TI defines "RoHS Exempt" to mean products that contain lead but are compliant with EU RoHS pursuant to a specific EU RoHS exemption.

Green: TI defines "Green" to mean the content of Chlorine (Cl) and Bromine (Br) based flame retardants meet JS709B low halogen requirements of <=1000ppm threshold. Antimony trioxide based flame retardants must also meet the <=1000ppm threshold requirement.

(3) MSL, Peak Temp. - The Moisture Sensitivity Level rating according to the JEDEC industry standard classifications, and peak solder temperature.

(4) There may be additional marking, which relates to the logo, the lot trace code information, or the environmental category on the device.

(5) Multiple Device Markings will be inside parentheses. Only one Device Marking contained in parentheses and separated by a "~" will appear on a device. If a line is indented then it is a continuation of the previous line and the two combined represent the entire Device Marking for that device.

⁽⁶⁾ Lead finish/Ball material - Orderable Devices may have multiple material finish options. Finish options are separated by a vertical ruled line. Lead finish/Ball material values may wrap to two lines if the finish value exceeds the maximum column width.

Important Information and Disclaimer:The information provided on this page represents TI's knowledge and belief as of the date that it is provided. TI bases its knowledge and belief on information provided by third parties, and makes no representation or warranty as to the accuracy of such information. Efforts are underway to better integrate information from third parties. TI has taken and continues to take reasonable steps to provide representative and accurate information but may not have conducted destructive testing or chemical analysis on incoming materials and chemicals. TI and TI suppliers consider certain information to be proprietary, and thus CAS numbers and other limited information may not be available for release.

In no event shall TI's liability arising out of such information exceed the total purchase price of the TI part(s) at issue in this document sold by TI to Customer on an annual basis.

OTHER QUALIFIED VERSIONS OF TPS2115A :

- Automotive : [TPS2115A-Q1](#)

NOTE: Qualified Version Definitions:

- Automotive - Q100 devices qualified for high-reliability automotive applications targeting zero defects

TAPE AND REEL INFORMATION

QUADRANT ASSIGNMENTS FOR PIN 1 ORIENTATION IN TAPE

*All dimensions are nominal

Device	Package Type	Package Drawing	Pins	SPQ	Reel Diameter (mm)	Reel Width W1 (mm)	A0 (mm)	B0 (mm)	K0 (mm)	P1 (mm)	W (mm)	Pin1 Quadrant
TPS2114APWR	TSSOP	PW	8	2000	330.0	12.4	7.0	3.6	1.6	8.0	12.0	Q1
TPS2115ADRBR	SON	DRB	8	3000	330.0	12.4	3.3	3.3	1.1	8.0	12.0	Q2
TPS2115ADRBT	SON	DRB	8	250	180.0	12.4	3.3	3.3	1.1	8.0	12.0	Q2
TPS2115APWR	TSSOP	PW	8	2000	330.0	12.4	7.0	3.6	1.6	8.0	12.0	Q1

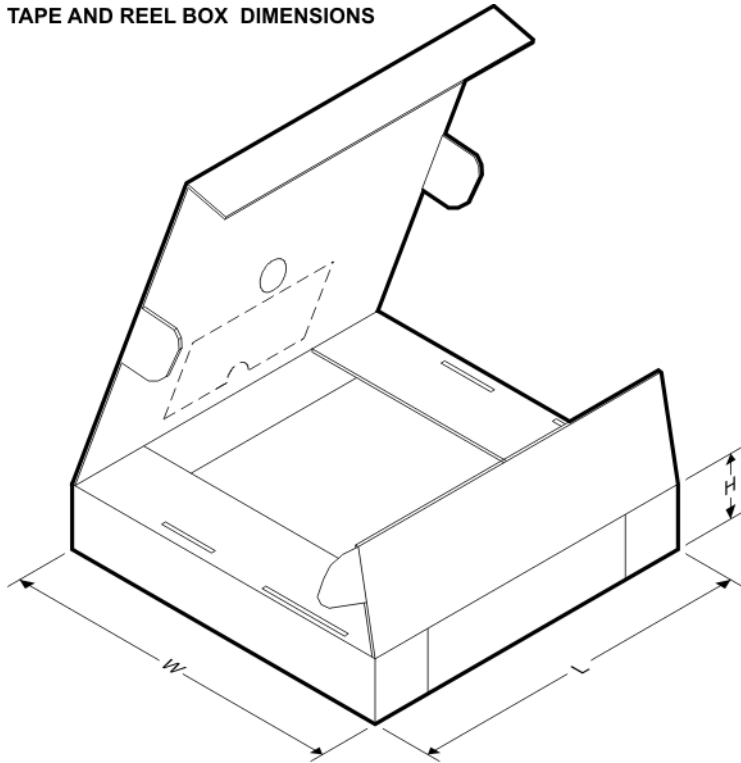
TAPE AND REEL BOX DIMENSIONS

*All dimensions are nominal

Device	Package Type	Package Drawing	Pins	SPQ	Length (mm)	Width (mm)	Height (mm)
TPS2114APWR	TSSOP	PW	8	2000	853.0	449.0	35.0
TPS2115ADRBR	SON	DRB	8	3000	367.0	367.0	35.0
TPS2115ADRBT	SON	DRB	8	250	210.0	185.0	35.0
TPS2115APWR	TSSOP	PW	8	2000	853.0	449.0	35.0

TUBE

*All dimensions are nominal

Device	Package Name	Package Type	Pins	SPQ	L (mm)	W (mm)	T (μm)	B (mm)
TPS2114APW	PW	TSSOP	8	150	530	10.2	3600	3.5
TPS2115APW	PW	TSSOP	8	150	530	10.2	3600	3.5

DRB 8

GENERIC PACKAGE VIEW

VSON - 1 mm max height

PLASTIC SMALL OUTLINE - NO LEAD



Images above are just a representation of the package family, actual package may vary.
Refer to the product data sheet for package details.

4203482/L

EXAMPLE BOARD LAYOUT

DRB0008B

VSON - 1 mm max height

PLASTIC SMALL OUTLINE - NO LEAD

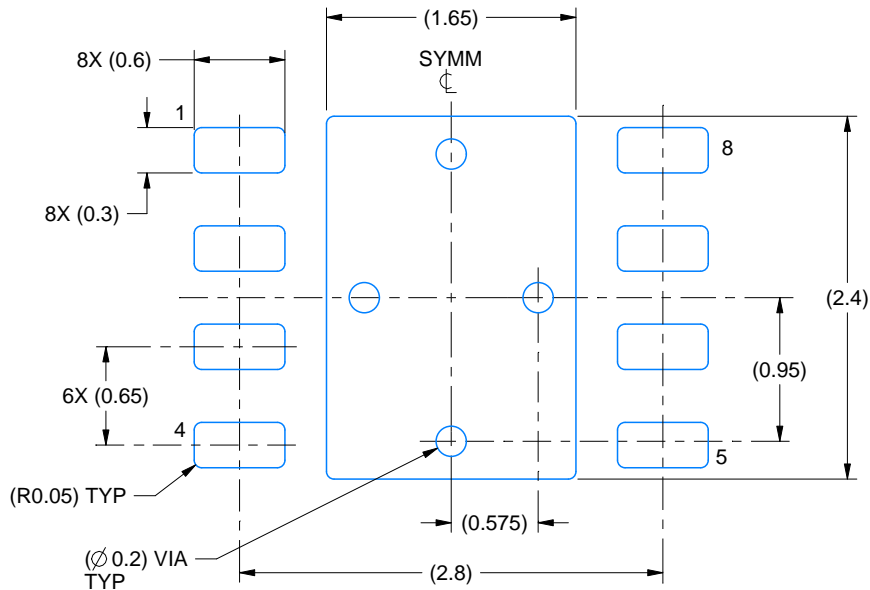

LAND PATTERN EXAMPLE
SCALE:20X

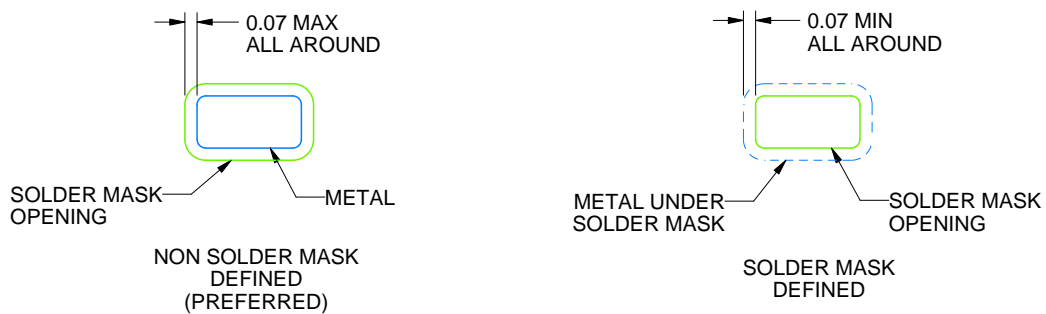

SOLDER MASK DETAILS

4218876/A 12/2017

NOTES: (continued)

4. This package is designed to be soldered to a thermal pad on the board. For more information, see Texas Instruments literature number SLUA271 (www.ti.com/lit/slua271).
5. Vias are optional depending on application, refer to device data sheet. If any vias are implemented, refer to their locations shown on this view. It is recommended that vias under paste be filled, plugged or tented.

EXAMPLE STENCIL DESIGN

DRB0008B

VSON - 1 mm max height

PLASTIC SMALL OUTLINE - NO LEAD

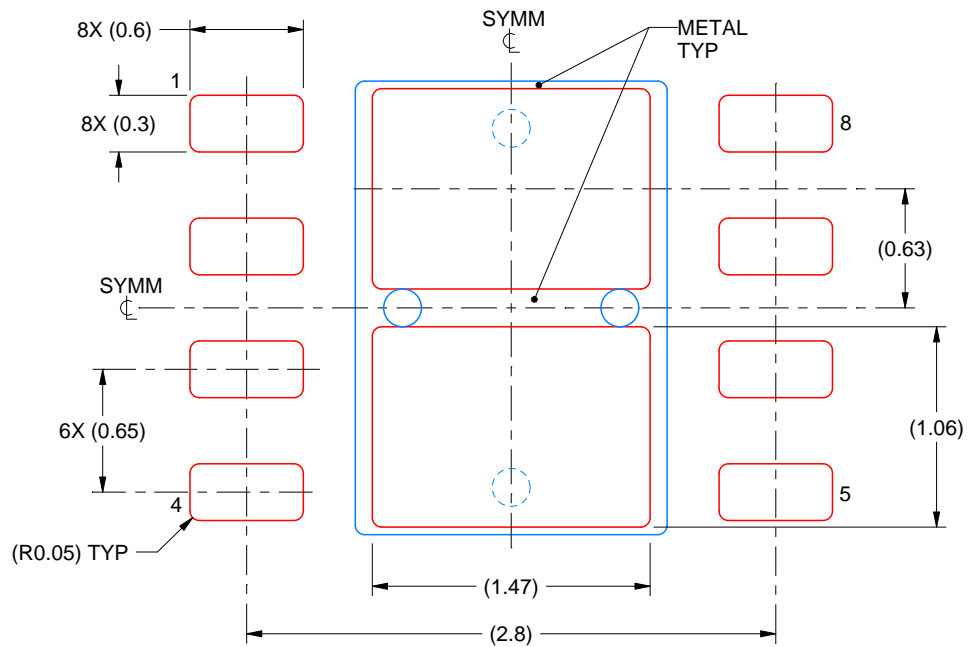

SOLDER PASTE EXAMPLE
BASED ON 0.125 mm THICK STENCIL

EXPOSED PAD
81% PRINTED SOLDER COVERAGE BY AREA
SCALE:25X

4218876/A 12/2017

NOTES: (continued)

6. Laser cutting apertures with trapezoidal walls and rounded corners may offer better paste release. IPC-7525 may have alternate design recommendations.

PW0008A



PACKAGE OUTLINE
TSSOP - 1.2 mm max height

SMALL OUTLINE PACKAGE



4221848/A 02/2015

NOTES:

1. All linear dimensions are in millimeters. Any dimensions in parenthesis are for reference only. Dimensioning and tolerancing per ASME Y14.5M.
2. This drawing is subject to change without notice.
3. This dimension does not include mold flash, protrusions, or gate burrs. Mold flash, protrusions, or gate burrs shall not exceed 0.15 mm per side.
4. This dimension does not include interlead flash. Interlead flash shall not exceed 0.25 mm per side.
5. Reference JEDEC registration MO-153, variation AA.

EXAMPLE BOARD LAYOUT

PW0008A

TSSOP - 1.2 mm max height

SMALL OUTLINE PACKAGE



LAND PATTERN EXAMPLE
SCALE:10X



SOLDER MASK DETAILS
NOT TO SCALE

4221848/A 02/2015

NOTES: (continued)

- 6. Publication IPC-7351 may have alternate designs.
- 7. Solder mask tolerances between and around signal pads can vary based on board fabrication site.

EXAMPLE STENCIL DESIGN

PW0008A

TSSOP - 1.2 mm max height

SMALL OUTLINE PACKAGE



SOLDER PASTE EXAMPLE
BASED ON 0.125 mm THICK STENCIL
SCALE:10X

4221848/A 02/2015

NOTES: (continued)

8. Laser cutting apertures with trapezoidal walls and rounded corners may offer better paste release. IPC-7525 may have alternate design recommendations.
9. Board assembly site may have different recommendations for stencil design.

IMPORTANT NOTICE AND DISCLAIMER

TI PROVIDES TECHNICAL AND RELIABILITY DATA (INCLUDING DATA SHEETS), DESIGN RESOURCES (INCLUDING REFERENCE DESIGNS), APPLICATION OR OTHER DESIGN ADVICE, WEB TOOLS, SAFETY INFORMATION, AND OTHER RESOURCES "AS IS" AND WITH ALL FAULTS, AND DISCLAIMS ALL WARRANTIES, EXPRESS AND IMPLIED, INCLUDING WITHOUT LIMITATION ANY IMPLIED WARRANTIES OF MERCHANTABILITY, FITNESS FOR A PARTICULAR PURPOSE OR NON-INFRINGEMENT OF THIRD PARTY INTELLECTUAL PROPERTY RIGHTS.

These resources are intended for skilled developers designing with TI products. You are solely responsible for (1) selecting the appropriate TI products for your application, (2) designing, validating and testing your application, and (3) ensuring your application meets applicable standards, and any other safety, security, regulatory or other requirements.

These resources are subject to change without notice. TI grants you permission to use these resources only for development of an application that uses the TI products described in the resource. Other reproduction and display of these resources is prohibited. No license is granted to any other TI intellectual property right or to any third party intellectual property right. TI disclaims responsibility for, and you will fully indemnify TI and its representatives against, any claims, damages, costs, losses, and liabilities arising out of your use of these resources.

TI's products are provided subject to [TI's Terms of Sale](#) or other applicable terms available either on ti.com or provided in conjunction with such TI products. TI's provision of these resources does not expand or otherwise alter TI's applicable warranties or warranty disclaimers for TI products.

TI objects to and rejects any additional or different terms you may have proposed.

Mailing Address: Texas Instruments, Post Office Box 655303, Dallas, Texas 75265
Copyright © 2022, Texas Instruments Incorporated