

## DS26LS31C/DS26LS31M Quad High Speed Differential Line Driver

 Check for Samples: [DS26LS31C](#), [DS26LS31M](#)

### FEATURES

- Output Skew—2.0 ns Typical
- Input to output delay—10 ns Typical
- Operation from Single 5V Supply
- Outputs Won't Load Line when  $V_{CC} = 0V$
- Four Line Drivers in One Package for Maximum Package Density
- Output Short-Circuit Protection
- Complementary Outputs
- Meets the Requirements of EIA Standard RS-422
- Pin Compatible with AM26LS31
- Available in Military and Commercial Temperature Range

### DESCRIPTION

The DS26LS31 is a quad differential line driver designed for digital data transmission over balanced lines. The DS26LS31 meets all the requirements of EIA Standard RS-422 and Federal Standard 1020. It is designed to provide unipolar differential drive to twisted-pair or parallel-wire transmission lines.

The circuit provides an enable and disable function common to all four drivers. The DS26LS31 features TRI-STATE outputs and logically ANDed complementary outputs. The inputs are all LS compatible and are all one unit load.

### Logic and Connection Diagrams

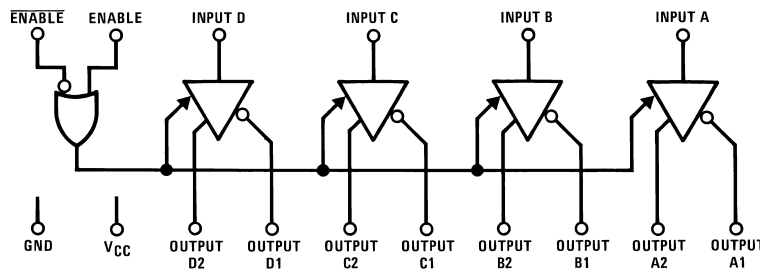

Top View

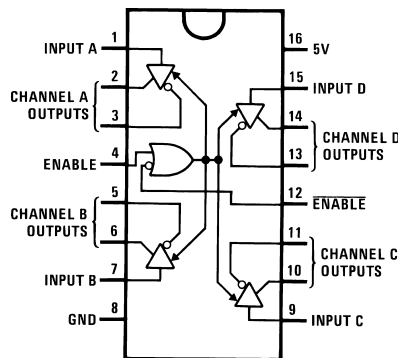

For Complete Military Product Specifications, refer to the appropriate SMD or MDS.

**Figure 1. PDIP Package**  
 See Package D0016A or NFG0016E  
 See Package Numbers NAJ0020A, NFE0016A or NAD0016A



Please be aware that an important notice concerning availability, standard warranty, and use in critical applications of Texas Instruments semiconductor products and disclaimers thereto appears at the end of this data sheet.

All trademarks are the property of their respective owners.



These devices have limited built-in ESD protection. The leads should be shorted together or the device placed in conductive foam during storage or handling to prevent electrostatic damage to the MOS gates.

### Absolute Maximum Ratings<sup>(1)(2)</sup>

Supply Voltage	7V
Input Voltage	7V
Output Voltage	5.5V
Output Voltage (Power OFF)	-0.25 to 6V
Maximum Power Dissipation <sup>(3)</sup> at 25°C	
Cavity Package	1509 mW
NFG0016E Package	1476 mW
D0016A Package	1051 mW

- (1) "Absolute Maximum Ratings" are those values beyond which the safety of the device cannot be verified. They are not meant to imply that the devices should be operated at these limits. The [Electrical Characteristics](#) provide conditions for actual device operation.
- (2) If Military/Aerospace specified devices are required, please contact the TI Sales Office/Distributors for availability and specifications.
- (3) Derate cavity package 10.1 mW/°C above 25°C; derate molded DIP package 11.9 mW/°C above 25°C; derate SO package 8.41 mW/°C above 25°C.

### Operating Conditions

	Min	Max	Units
Supply Voltage, $V_{CC}$			
DS26LS31M	4.5	5.5	V
DS26LS31	4.75	5.25	V
Temperature, $T_A$			
DS26LS31M	-55	+125	°C
DS26LS31	0	+70	°C

### Electrical Characteristics<sup>(1)(2)(3)</sup>

Parameter		Test Conditions	Min	Typ	Max	Units
$V_{OH}$	Output High Voltage	$I_{OH} = -20$ mA	2.5			V
$V_{OL}$	Output Low Voltage	$I_{OL} = 20$ mA			0.5	V
$V_{IH}$	Input High Voltage		2.0			V
$V_{IL}$	Input Low Voltage				0.8	V
$I_{iL}$	Input Low Current	$V_{IN} = 0.4$ V		-40	-200	μA
$I_{iH}$	Input High Current	$V_{IN} = 2.7$ V			20	μA
$I_i$	Input Reverse Current	$V_{IN} = 7$ V			0.1	mA
$I_O$	TRI-STATE Output Current	$V_O = 2.5$ V			20	μA
		$V_O = 0.5$ V			-20	μA
$V_{CL}$	Input Clamp Voltage	$I_{IN} = -18$ mA			-1.5	V
$I_{SC}$	Output Short-Circuit Current		-30		-150	mA
$I_{CC}$	Power Supply Current	All Outputs Disabled or Active		35	60	mA

- (1) Unless otherwise specified min/max limits apply across the -55°C to +125°C temperature range for the DS26LS31M and across the 0°C to +70°C range for the DS26LS31. All typicals are given for  $V_{CC} = 5$  V and  $T_A = 25$ °C.
- (2) All currents into device pins are positive; all currents out of device pins are negative. All voltages are referenced to ground unless otherwise specified.
- (3) Only one output at a time should be shorted.

### Switching Characteristics

$V_{CC} = 5V, T_A = 25^\circ C$

Parameter	Test Conditions	Min	Typ	Max	Units
$t_{PLH}$	Input to Output $C_L = 30 \text{ pF}$		10	15	ns
$t_{PHL}$	Input to Output $C_L = 30 \text{ pF}$		10	15	ns
Skew	Output to Output $C_L = 30 \text{ pF}$		2.0	6.0	ns
$t_{LZ}$	Enable to Output $C_L = 10 \text{ pF}, S2 \text{ Open}$		15	35	ns
$t_{HZ}$	Enable to Output $C_L = 10 \text{ pF}, S1 \text{ Open}$		15	25	ns
$t_{ZL}$	Enable to Output $C_L = 30 \text{ pF}, S2 \text{ Open}$		20	30	ns
$t_{ZH}$	Enable to Output $C_L = 30 \text{ pF}, S1 \text{ Open}$		20	30	ns

### AC TEST CIRCUIT AND SWITCHING TIME WAVEFORMS

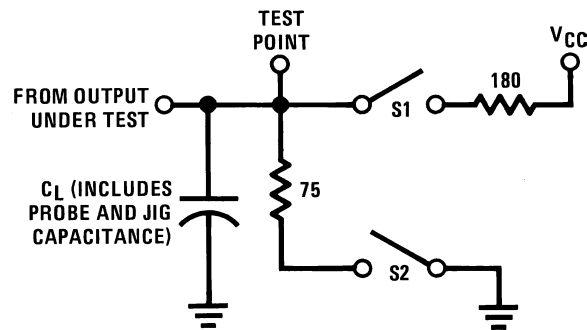

S1 and S2 of load circuit are closed except where shown.

Figure 2. AC Test Circuit

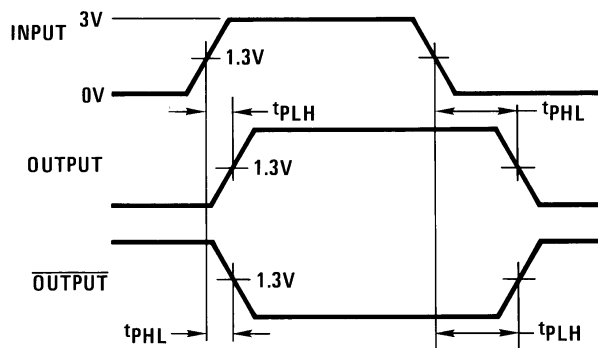

$f = 1 \text{ MHz}, t_r \leq 15 \text{ ns}, t_f \leq 6 \text{ ns}$

Figure 3. Propagation Delays

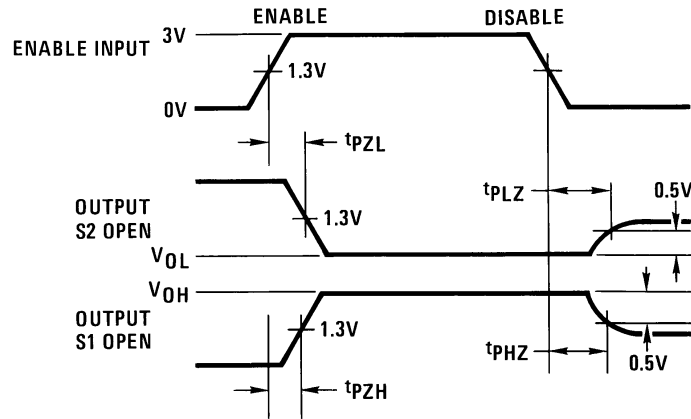

f = 1 MHz,  $t_r \leq 15$  ns,  $t_f \leq 6$  ns

Figure 4. Enable and Disable Times

TYPICAL APPLICATIONS

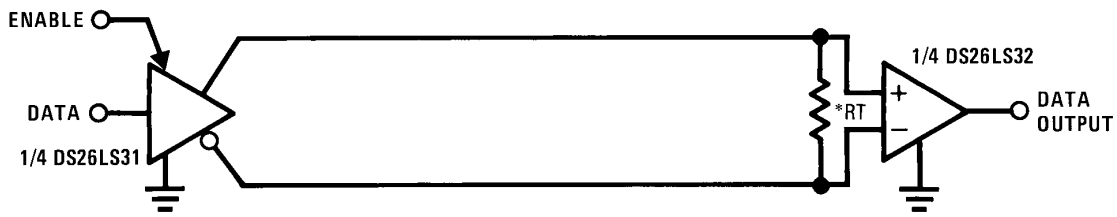

$R_T$  is optional although highly recommended to reduce reflection.

Figure 5. Two-Wire Balanced System, RS-422

Typical Performance Characteristics

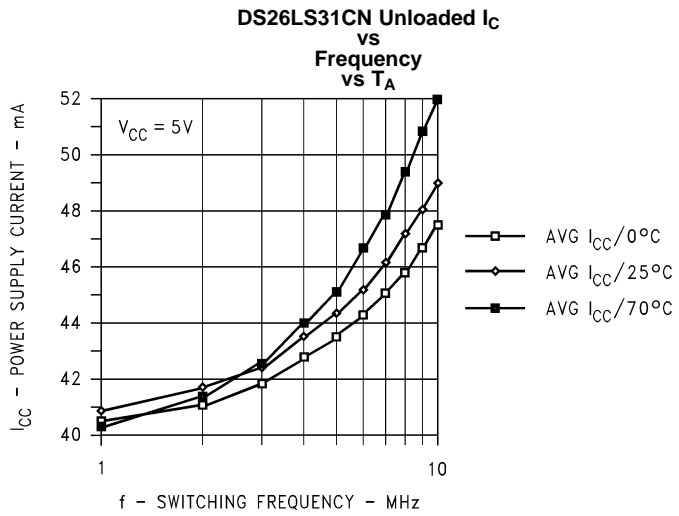

Figure 6.

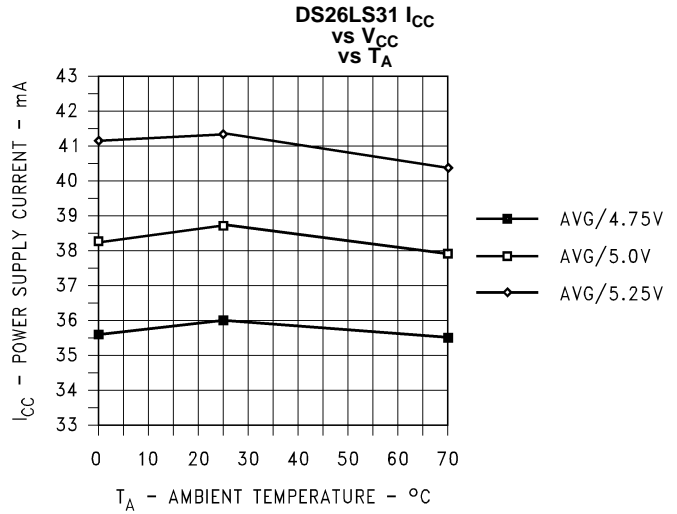

Figure 7.

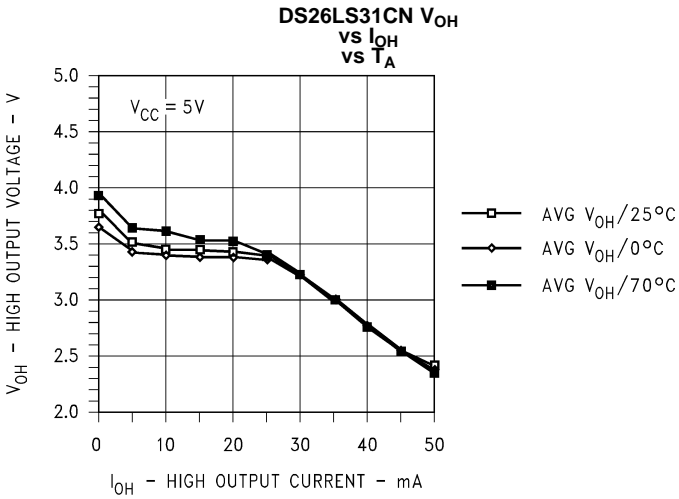

Figure 8.

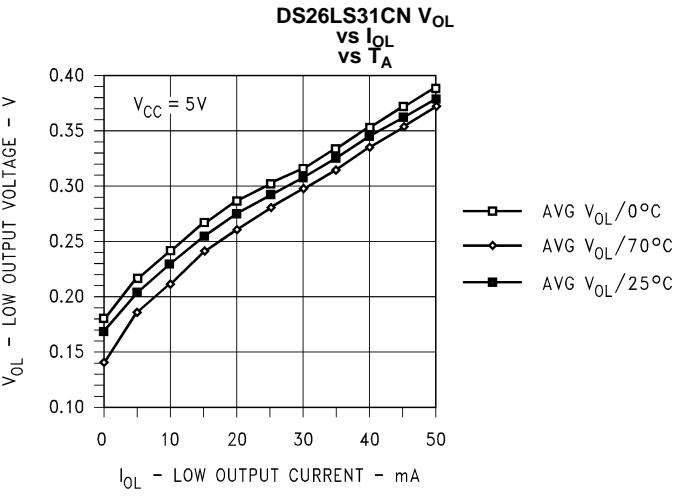

Figure 9.

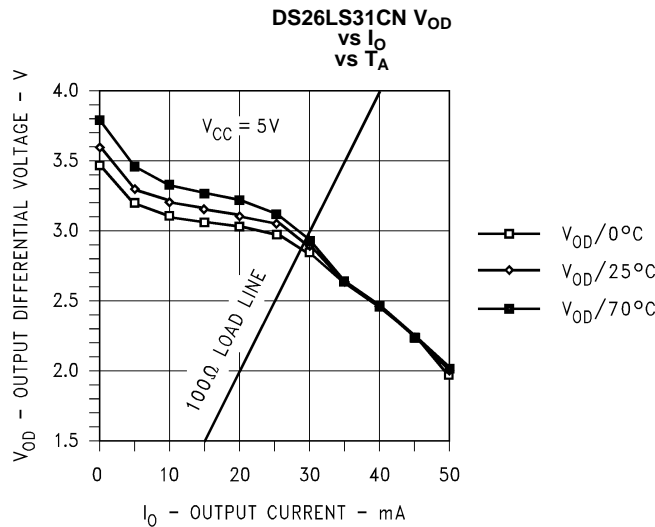

Figure 10.

## REVISION HISTORY

Changes from Revision B (April 2013) to Revision C	Page
• Changed layout of National Data Sheet to TI format .....	<a href="#">5</a>

**PACKAGING INFORMATION**

Orderable Device	Status (1)	Package Type	Package Drawing	Pins	Package Qty	Eco Plan (2)	Lead finish/ Ball material (6)	MSL Peak Temp (3)	Op Temp (°C)	Device Marking (4/5)	Samples
DS26LS31CM/NOPB	ACTIVE	SOIC	D	16	48	RoHS & Green	SN	Level-1-260C-UNLIM	0 to 70	DS26LS31CM	<a href="#">Samples</a>
DS26LS31CMX/NOPB	ACTIVE	SOIC	D	16	2500	RoHS & Green	SN	Level-1-260C-UNLIM	0 to 70	DS26LS31CM	<a href="#">Samples</a>

(1) The marketing status values are defined as follows:

**ACTIVE:** Product device recommended for new designs.

**LIFEBUY:** TI has announced that the device will be discontinued, and a lifetime-buy period is in effect.

**NRND:** Not recommended for new designs. Device is in production to support existing customers, but TI does not recommend using this part in a new design.

**PREVIEW:** Device has been announced but is not in production. Samples may or may not be available.

**OBSELETE:** TI has discontinued the production of the device.

(2) **RoHS:** TI defines "RoHS" to mean semiconductor products that are compliant with the current EU RoHS requirements for all 10 RoHS substances, including the requirement that RoHS substance do not exceed 0.1% by weight in homogeneous materials. Where designed to be soldered at high temperatures, "RoHS" products are suitable for use in specified lead-free processes. TI may reference these types of products as "Pb-Free".

**RoHS Exempt:** TI defines "RoHS Exempt" to mean products that contain lead but are compliant with EU RoHS pursuant to a specific EU RoHS exemption.

**Green:** TI defines "Green" to mean the content of Chlorine (Cl) and Bromine (Br) based flame retardants meet JS709B low halogen requirements of <=1000ppm threshold. Antimony trioxide based flame retardants must also meet the <=1000ppm threshold requirement.

(3) MSL, Peak Temp. - The Moisture Sensitivity Level rating according to the JEDEC industry standard classifications, and peak solder temperature.

(4) There may be additional marking, which relates to the logo, the lot trace code information, or the environmental category on the device.

(5) Multiple Device Markings will be inside parentheses. Only one Device Marking contained in parentheses and separated by a "~" will appear on a device. If a line is indented then it is a continuation of the previous line and the two combined represent the entire Device Marking for that device.

(6) Lead finish/Ball material - Orderable Devices may have multiple material finish options. Finish options are separated by a vertical ruled line. Lead finish/Ball material values may wrap to two lines if the finish value exceeds the maximum column width.

**Important Information and Disclaimer:**The information provided on this page represents TI's knowledge and belief as of the date that it is provided. TI bases its knowledge and belief on information provided by third parties, and makes no representation or warranty as to the accuracy of such information. Efforts are underway to better integrate information from third parties. TI has taken and continues to take reasonable steps to provide representative and accurate information but may not have conducted destructive testing or chemical analysis on incoming materials and chemicals. TI and TI suppliers consider certain information to be proprietary, and thus CAS numbers and other limited information may not be available for release.

In no event shall TI's liability arising out of such information exceed the total purchase price of the TI part(s) at issue in this document sold by TI to Customer on an annual basis.



**TAPE AND REEL INFORMATION**

**QUADRANT ASSIGNMENTS FOR PIN 1 ORIENTATION IN TAPE**

\*All dimensions are nominal

Device	Package Type	Package Drawing	Pins	SPQ	Reel Diameter (mm)	Reel Width W1 (mm)	A0 (mm)	B0 (mm)	K0 (mm)	P1 (mm)	W (mm)	Pin1 Quadrant
DS26LS31CMX/NOPB	SOIC	D	16	2500	330.0	16.4	6.5	10.3	2.3	8.0	16.0	Q1

**TAPE AND REEL BOX DIMENSIONS**

\*All dimensions are nominal

Device	Package Type	Package Drawing	Pins	SPQ	Length (mm)	Width (mm)	Height (mm)
DS26LS31CMX/NOPB	SOIC	D	16	2500	853.0	449.0	35.0

**TUBE**

\*All dimensions are nominal

Device	Package Name	Package Type	Pins	SPQ	L (mm)	W (mm)	T (μm)	B (mm)
DS26LS31CM/NOPB	D	SOIC	16	48	495	8	4064	3.05

D (R-PDSO-G16)

PLASTIC SMALL OUTLINE



- NOTES:
- A. All linear dimensions are in inches (millimeters).
  - B. This drawing is subject to change without notice.
  - C. Body length does not include mold flash, protrusions, or gate burrs. Mold flash, protrusions, or gate burrs shall not exceed 0.006 (0,15) each side.
  - D. Body width does not include interlead flash. Interlead flash shall not exceed 0.017 (0,43) each side.
  - E. Reference JEDEC MS-012 variation AC.

## IMPORTANT NOTICE AND DISCLAIMER

TI PROVIDES TECHNICAL AND RELIABILITY DATA (INCLUDING DATA SHEETS), DESIGN RESOURCES (INCLUDING REFERENCE DESIGNS), APPLICATION OR OTHER DESIGN ADVICE, WEB TOOLS, SAFETY INFORMATION, AND OTHER RESOURCES "AS IS" AND WITH ALL FAULTS, AND DISCLAIMS ALL WARRANTIES, EXPRESS AND IMPLIED, INCLUDING WITHOUT LIMITATION ANY IMPLIED WARRANTIES OF MERCHANTABILITY, FITNESS FOR A PARTICULAR PURPOSE OR NON-INFRINGEMENT OF THIRD PARTY INTELLECTUAL PROPERTY RIGHTS.

These resources are intended for skilled developers designing with TI products. You are solely responsible for (1) selecting the appropriate TI products for your application, (2) designing, validating and testing your application, and (3) ensuring your application meets applicable standards, and any other safety, security, regulatory or other requirements.

These resources are subject to change without notice. TI grants you permission to use these resources only for development of an application that uses the TI products described in the resource. Other reproduction and display of these resources is prohibited. No license is granted to any other TI intellectual property right or to any third party intellectual property right. TI disclaims responsibility for, and you will fully indemnify TI and its representatives against, any claims, damages, costs, losses, and liabilities arising out of your use of these resources.

TI's products are provided subject to [TI's Terms of Sale](#) or other applicable terms available either on [ti.com](http://ti.com) or provided in conjunction with such TI products. TI's provision of these resources does not expand or otherwise alter TI's applicable warranties or warranty disclaimers for TI products.

TI objects to and rejects any additional or different terms you may have proposed.

Mailing Address: Texas Instruments, Post Office Box 655303, Dallas, Texas 75265  
Copyright © 2022, Texas Instruments Incorporated