

# 用于 电磁阀、继电器和阀门的 DRV110 120V 和 230V 交流、6V 至 48V 直流电 流控制器

## 1 特性

- 适合高压工作的电源引脚内部齐纳二极管
  - 借助整流器和  $R_S$  电阻器由 120V 和 230V 交流电源供电
  - 借助  $R_S$  电阻器由 24V、48V 及更高交流电源供电
- 驱动具有 PWM 的外部 MOSFET 以控制电磁阀电流
  - 用于调节电磁阀电流的外部感应电阻器
- 电磁阀电流快速斜升以确保激活
- 在保持模式下，减少电磁阀电流以降低功耗和热耗散
- 可在外部设置斜坡峰值电流、峰值电流持续时间、维持电流和 PWM 时钟频率。还可将这些参数设置为标称值，而无需使用外部组件。
- 保护
  - 热关断
  - 欠压锁定 (UVLO)
- 可选状态输出
- 工作温度范围：-40°C 至 +125°C
- 8 引脚和 14 引脚 TSSOP 封装选项

## 2 应用

- 机电驱动器：电磁阀、阀门、继电器、接触器、开关设备、气动阀
- 大型家电、太阳能、运输、智能电网、配电

## 3 说明

DRV110 器件是一款面向电磁阀的 PWM 电流控制器。该器件旨在通过良好受控的波形来调节电流，从而减少功率损耗。电磁阀电流快速斜升，可确保正常打开阀门或继电器。最初上升后，电磁阀电流将保持峰值以确保正常运行；此后，电流降至较低的保持水平，以避免过热问题并减少功率损耗。

使用外部电容器设置峰值电流持续时间。可使用外部电阻器单独设置电流斜坡的峰值和保持水平以及 PWM 频率。如果相应参数的默认值适用于该应用，甚至无需使用外部设置电阻器。

DRV110 器件具有内部齐纳二极管，可将输入电压限制到  $V_{ZENER}$ ，适用于需要较高电源电压的应用。借助内部齐纳二极管，DRV110 允许通过整流器和限流电阻器由 120V 和 230V 交流电源供电。也可通过此方式调节高直流电压，例如 48V。

器件信息<sup>(1)</sup>

器件型号	封装	封装尺寸 (标称值)
DRV110	TSSOP (14)	5.00mm x 4.40mm
	TSSOP (8)	3.00mm x 4.40mm

(1) 如需了解所有可用封装，请参阅数据表末尾的可订购产品目录。

DRV110 由电源线电压供电

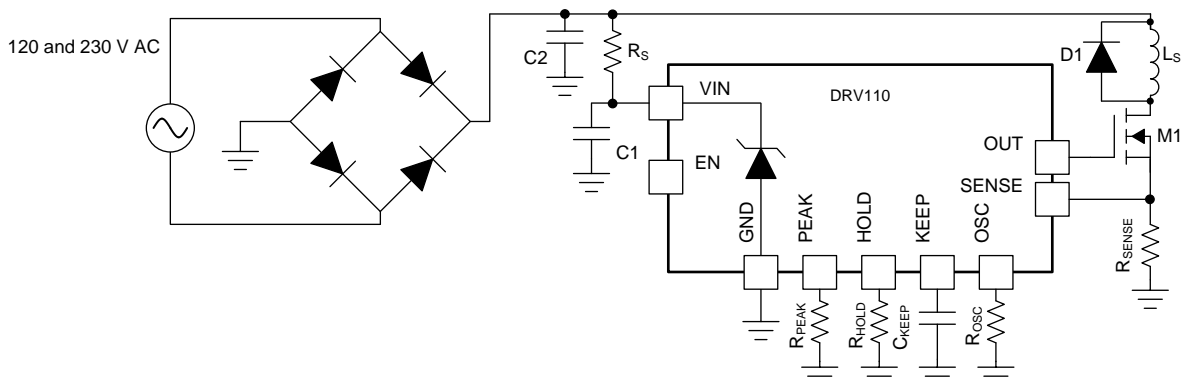

Copyright © 2018, Texas Instruments Incorporated



目录

1	特性 .....	1	7.4	Device Functional Modes .....	13
2	应用 .....	1	8	<b>Application and Implementation</b> .....	14
3	说明 .....	1	8.1	Application Information .....	14
4	修订历史记录 .....	2	8.2	Typical Application .....	14
5	<b>Pin Configuration and Functions</b> .....	4	9	<b>Power Supply Recommendations</b> .....	17
6	<b>Specifications</b> .....	5	10	<b>Layout</b> .....	17
6.1	Absolute Maximum Ratings .....	5	10.1	Layout Guidelines .....	17
6.2	ESD Ratings .....	5	10.2	Layout Example .....	18
6.3	Recommended Operating Conditions .....	5	11	器件和文档支持 .....	19
6.4	Thermal Information .....	5	11.1	文档支持 .....	19
6.5	Electrical Characteristics .....	6	11.2	接收文档更新通知 .....	19
6.6	Typical Characteristics .....	7	11.3	社区资源 .....	19
7	<b>Detailed Description</b> .....	8	11.4	商标 .....	19
7.1	Overview .....	8	11.5	静电放电警告 .....	19
7.2	Functional Block Diagram .....	8	11.6	Glossary .....	19
7.3	Feature Description .....	9	12	机械、封装和可订购信息 .....	19

4 修订历史记录

注：之前版本的页码可能与当前版本有所不同。

Changes from Revision F (March 2017) to Revision G	Page
• 已更改 将齐纳二极管限制的最大电源电压从 15V 更改为 $V_{ZENER}$ .....	1
• Deleted <i>virtual</i> from the operating junction temperature and changed its maximum value from 125°C to 150°C in the <i>Absolute Maximum Ratings</i> table .....	5
• Added the temperature range for the parameters in the <i>Recommended Operating Conditions</i> table, add the $V_S$ parameter, and updated the $V_{IN}$ and $I_Q$ parameters .....	5
• Deleted the solenoid inductance parameter from the <i>Recommended Operating Conditions</i> table .....	5
• Deleted the $I_{VIN}$ test condition from the gate drive voltage parameter in the <i>Electrical Characteristics</i> table .....	6
• Changed the parameter names for $V_{PEAK}$ and $V_{HOLD}$ in the <i>Electrical Characteristics</i> table .....	6
• Added the input pulldown resistance parameter in the <i>Electrical Characteristics</i> table .....	6
• Added the <i>DRV110 Current Control with Varying OUT Duty Cycle</i> image to the <i>PWM Current Control</i> section .....	10
• Changed the $R_{PEAK}$ value for $I_{PEAK} = 450$ mA from 50 k $\Omega$ to 55 k $\Omega$ in the <i>Configuring Peak and Hold Currents</i> section....	10
• Changed the <i>Configuring Peak and Hold Currents</i> section and <i>PEAK and HOLD Mode <math>V_{REF}</math> Settings</i> image (which is now named <i><math>I_{PEAK}</math> and <math>I_{HOLD}</math> settings for <math>R_{SENSE} = 1 \Omega</math></i> ) .....	11
• Changed the <i>Voltage Supply and Integrated Zener Diode</i> section. Added the <i><math>V_{ZENER}</math> Value</i> table and changed the $R_S$ equation to specify calculations for $R_{S,max}$ and $R_{S,min}$ .....	12
• Deleted the <i>Default Configuration</i> schematic .....	14
• Added the <i>Current Limiting Resistor Selection</i> and <i>Passives Selection</i> sections in the <i>Detailed Design Procedure</i> .....	15
• Changed the value of $R_{PEAK}$ from 303 k $\Omega$ to 400 k $\Omega$ in the <i>Application Curve</i> .....	17

Changes from Revision E (November 2016) to Revision F	Page
• Changed the <i>Functional Block Diagram</i> .....	8
• Changed the $I_{HOLD}$ equation .....	11
• Changed the <i>Shutdown</i> section to provide a description of the STATUS pin. ....	13

---

**Changes from Revision D (June 2016) to Revision E** **Page**

---

- 已更改 文档标题，在其中添加了交流电压和直流电压值 ..... 1
  - 修订了 特性 和应用列表 ..... 1
  - 已更改 首页图形至原理图 ..... 1
  - Revised table notes for *Recommended Operating Conditions* table..... 5
- 

**Changes from Revision C (April 2016) to Revision D** **Page**

---

- 已更改 文档标题..... 1
  - Changed 160 kΩ in the  $f_{PWM}$  equation to 66.67 kΩ ..... 11
  - 已添加 接收文档更新通知 部分 ..... 19
- 

**Changes from Revision B (July 2015) to Revision C** **Page**

---

- Changed one test condition ( $R_{OSC} = 50\text{ k}\Omega$  to  $160\text{ k}\Omega$ ) and the maximum value for the Externally set PWM clock frequency (60 to 25) in the *Electrical Characteristics* table ..... 6
  - Changed the *PWM Clock Frequency Setting* graph..... 11
- 

**Changes from Revision A (January 2013) to Revision B** **Page**

---

- 已添加 添加了 *ESD* 额定值表、特性 说明部分、器件功能模式、应用和实施部分、电源相关建议部分、布局部分、器件和文档支持部分以及机械、封装和可订购信息部分 ..... 1
-

## 5 Pin Configuration and Functions

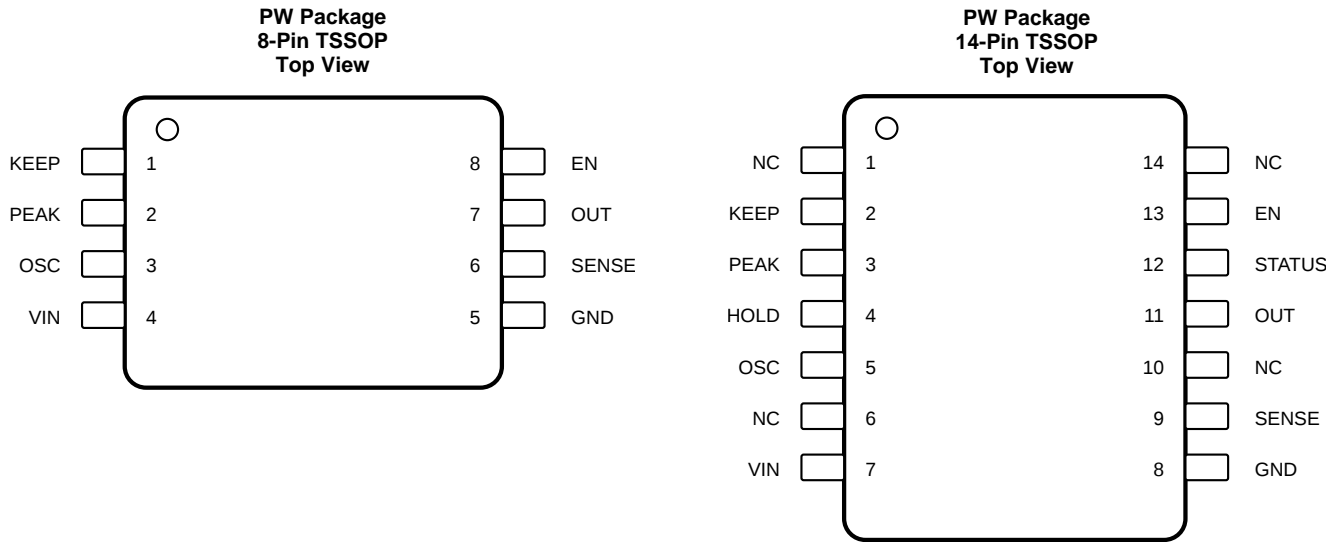

### Pin Functions

NAME	PIN NO.		I/O	DESCRIPTION
	8 PINS	14 PINS		
EN	8	13	I	Enable
GND	5	8	—	Ground
HOLD	—	4	I	Hold current set <sup>(1)</sup>
KEEP	1	2	I	Keep time set
NC	—	1	—	No connect
NC	—	6	—	No connect
NC	—	10	—	No connect
NC	—	14	—	No connect
OSC	3	5	I	PWM frequency set
OUT	7	11	O	Solenoid switch gate drive
PEAK	2	3	I	Peak current set
SENSE	6	9	I	Solenoid current sense
STATUS	—	12	O	Open drain status indicator
VIN	4	7	I	6-V to 15-V supply

(1) In the 8-pin package, the HOLD pin is not bonded out. For this package, the HOLD mode is configured to default (internal) settings.

## 6 Specifications

### 6.1 Absolute Maximum Ratings

See <sup>(1)</sup> and <sup>(2)</sup>

		MIN	MAX	UNIT
V <sub>IN</sub>	Input voltage	-0.3	20	V
	Voltage on EN, STATUS, PEAK, HOLD, OSC, SENSE, KEEP	-0.3	7	V
	Voltage on OUT	-0.3	20	V
T <sub>J</sub>	Operating junction temperature	-40	150	°C
T <sub>stg</sub>	Storage temperature	-65	150	°C

- (1) Stresses beyond those listed under *Absolute Maximum Ratings* may cause permanent damage to the device. These are stress ratings only, and functional operation of the device at these or any other conditions beyond those indicated under *Recommended Operating Conditions* is not implied. Exposure to absolute-maximum-rated conditions for extended periods may affect device reliability.
- (2) All voltage values are with respect to network ground terminal.

### 6.2 ESD Ratings

		VALUE	UNIT
V <sub>(ESD)</sub>	Electrostatic discharge	Human body model (HBM), per ANSI/ESDA/JEDEC JS-001 <sup>(1)</sup>	±2000
		Charged device model (CDM), per JEDEC specification JESD22-C101 <sup>(2)</sup>	±500

- (1) JEDEC document JEP155 states that 500-V HBM allows safe manufacturing with a standard ESD control process.
- (2) JEDEC document JEP157 states that 250-V CDM allows safe manufacturing with a standard ESD control process.

### 6.3 Recommended Operating Conditions

-40°C ≤ T<sub>A</sub> ≤ 125°C (unless otherwise noted)

		MIN	NOM	MAX	UNIT
I <sub>Q</sub>	Supply current (the device sinks additional current when V <sub>IN</sub> > V <sub>ZENER</sub> <sup>(1)</sup> )	1	1.5	3	mA
V <sub>IN</sub>	Voltage at the VIN pin <sup>(2)(3)</sup> (see <a href="#">Detailed Description</a> )	6			V
V <sub>S</sub>	Voltage directly from the supply before clamped by the Zener diode	6		330	V
C <sub>IN</sub>	Input capacitor between VIN and GND <sup>(4)</sup>	1	4.7		µF
T <sub>A</sub>	Operating ambient temperature	-40		125	°C

- (1) The device regulates the supply with an internal Zener diode. The device sinks up to 3 mA with the added supply current. See [Equation 5](#) to find appropriate value for the R<sub>S</sub> resistor.
- (2) The maximum input voltage of the device depends on the clamping voltage of the internal Zener diode, which changes over temperature. A current-limiting resistor is required to limit current to the Zener diode if the input voltage (V<sub>IN</sub>) is greater than V<sub>ZENER</sub>. For more information on resistor sizing see the [Detailed Description](#) section and [Application and Implementation](#) section.
- (3) For V<sub>S</sub> voltages less than V<sub>ZENER</sub>, V<sub>IN</sub> = V<sub>S</sub>. For V<sub>S</sub> voltages greater than V<sub>ZENER</sub>, V<sub>IN</sub> = V<sub>ZENER</sub>.
- (4) 4.7-µF input capacitor and full wave rectified 230-Vrms AC supply results in approximately 500-mV supply ripple.

### 6.4 Thermal Information

THERMAL METRIC <sup>(1)</sup>	DRV110		UNIT	
	PW (TSSOP)			
	8 PINS	14 PINS		
R <sub>θJA</sub>	Junction-to-ambient thermal resistance	183.8	122.6	°C/W
R <sub>θJC(top)</sub>	Junction-to-case (top) thermal resistance	69.2	51.2	°C/W
R <sub>θJB</sub>	Junction-to-board thermal resistance	112.6	64.3	°C/W
ψ <sub>JT</sub>	Junction-to-top characterization parameter	10.4	6.5	°C/W
ψ <sub>JB</sub>	Junction-to-board characterization parameter	110.9	63.7	°C/W
R <sub>θJC(bot)</sub>	Junction-to-case (bottom) thermal resistance	N/A	N/A	°C/W

- (1) For more information about traditional and new thermal metrics, see the [Semiconductor and IC Package Thermal Metrics application report](#).

## 6.5 Electrical Characteristics

 $V_{IN} = 14\text{ V}$ ,  $-40^{\circ}\text{C} \leq T_A \leq 125^{\circ}\text{C}$ , over operating free-air temperature range (unless otherwise noted)

PARAMETER		TEST CONDITIONS	MIN	TYP	MAX	UNIT
<b>SUPPLY</b>						
$I_Q$	Standby current	EN = 0, $V_{IN} = 14\text{ V}$ , bypass deactivated		200	250	$\mu\text{A}$
	Quiescent current	EN = 1, $V_{IN} = 14\text{ V}$ , bypass deactivated		360	570	
	Internally regulated supply	EN = 0, $I_{VIN} = 2\text{ mA}$ , bypass activated	10.5	15	19	V
		EN = 1, $I_{VIN} = 2\text{ mA}$ , bypass activated	14.5	15	15.5	
<b>GATE DRIVER</b>						
$V_{DRV}$	Gate drive voltage	Supply voltage in regulation		$V_{IN}$		V
$I_{DRV\_SINK}$	Gate drive sink current	$V_{OUT} = 15\text{ V}$ ; $V_{IN} = 15\text{ V}$	8	15		mA
$I_{DRV\_SOURCE}$	Gate drive source current	$V_{OUT} = \text{GND}$ ; $V_{IN} = 15\text{ V}$		-15	-10	mA
$f_{PWM}$	PWM clock frequency	OSC = GND	15	20	27	kHz
$D_{MAX}$	Maximum PWM duty cycle			100%		
$D_{MIN}$	Minimum PWM duty cycle			7.5%		
$t_D$	Start-up delay	Delay between EN going high until gate driver starts switching, $f_{PWM} = 20\text{ kHz}$			50	$\mu\text{s}$
<b>CURRENT CONTROLLER, INTERNAL SETTINGS</b>						
$I_{PEAK}$	Peak current	$R_{SENSE} = 1\ \Omega$ , PEAK = GND	270	300	330	mA
$I_{HOLD}$	Hold current	$R_{SENSE} = 1\ \Omega$ , HOLD = GND	40	50	65	mA
<b>CURRENT CONTROLLER, EXTERNAL SETTINGS</b>						
$t_{KEEP}$	Externally set keep time at peak current	$C_{KEEP} = 1\ \mu\text{F}$		100		ms
$V_{PEAK}$	Voltage of internal reference to which the SENSE pin voltage is compared to for $I_{PEAK}$	$R_{PEAK} = 50\text{ k}\Omega$		900		mV
		$R_{PEAK} = 200\text{ k}\Omega$		300		
$V_{HOLD}$	Voltage of internal reference to which the SENSE pin voltage is compared to for $I_{HOLD}$	$R_{HOLD} = 50\text{ k}\Omega$		150		mV
		$R_{HOLD} = 200\text{ k}\Omega$		50		
$f_{PWM}$	Externally set PWM clock frequency	$R_{OSC} = 160\text{ k}\Omega$		25		kHz
		$R_{OSC} = 200\text{ k}\Omega$		20		
<b>LOGIC INPUT LEVELS (EN)</b>						
$V_{IL}$	Input low level				1.3	V
$V_{IH}$	Input high level		1.65			V
$R_{EN}$	Input pullup resistance		350	500		$\text{k}\Omega$
	Input pulldown resistance			250		$\text{k}\Omega$
<b>LOGIC OUTPUT LEVELS (STATUS)</b>						
$V_{OL}$	Output low level	Pulldown activated, $I_{STATUS} = 2\text{ mA}$			0.3	V
$I_{IL}$	Output leakage current	Pulldown deactivated, $V(\text{STATUS}) = 5\text{ V}$			2	$\mu\text{A}$
<b>UNDERVOLTAGE LOCKOUT</b>						
$V_{UVLO}$	Undervoltage lockout threshold			4.6		V
<b>THERMAL SHUTDOWN</b>						
$T_{TSU}$	Junction temperature start-up threshold			140		$^{\circ}\text{C}$
$T_{TSD}$	Junction temperature shutdown threshold			160		$^{\circ}\text{C}$

## 6.6 Typical Characteristics

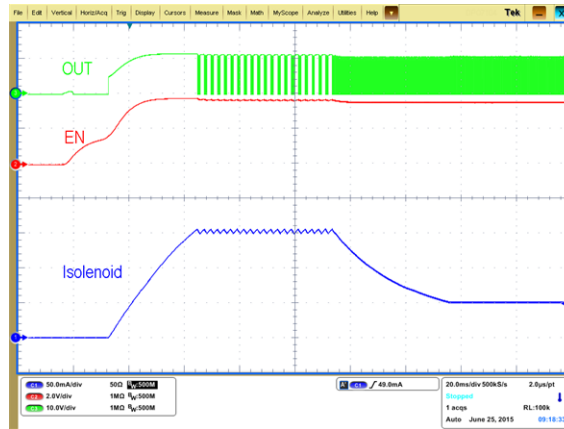

Figure 1. Solenoid Current, EN, and PWM vs Time

## 7 Detailed Description

### 7.1 Overview

The DRV110 device provides a PWM current controller for use with solenoids. The device provides a quick ramp to a high peak current value in order to ensure opening of the valve or relay. The current is held for a programmable time and then lowered to the hold current value to maintain the open state of the valve or relay while reducing the total current consumption. Peak current duration, peak current amount, hold current amount (in the 14-pin package), and PWM frequency can all be controlled by external components or used at default levels by omitting these components (except peak current duration).

Enable and disable of the switch is controlled by the EN pin. The EN pin contains an internal resistor network to set the pin to logic HIGH when the EN pin is floating. This feature can be used for situations where a control signal is not required and the solenoid is only energized when a supply voltage is present. Such applications could be valves or contactors.

The DRV110 also features a wide VIN range with an internal bypass regulator to maintain VIN at an acceptable level. Finally, the 14-pin package features an open-drain pull-down path on the STATUS pin which is enabled as long as undervoltage lockout or thermal shutdown has not triggered.

### 7.2 Functional Block Diagram

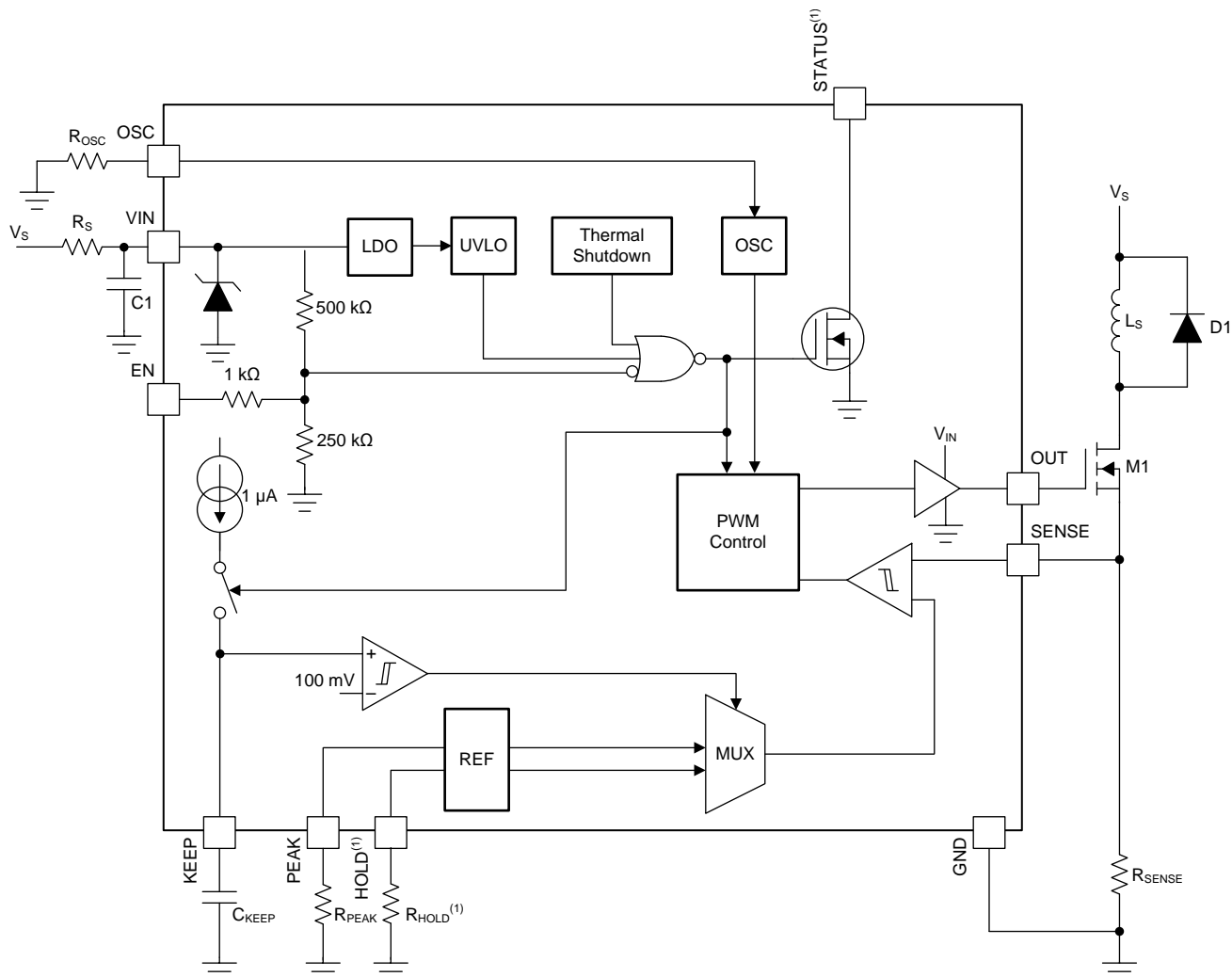

Copyright © 2017, Texas Instruments Incorporated

(1) Available only in the 14-pin package.

### 7.3 Feature Description

The DRV110 controls the current through the solenoid as shown in [Figure 2](#). Activation starts when EN pin voltage is pulled high either by an external driver or internal pullup. In the beginning of activation, DRV110 allows the solenoid current to ramp up to the peak value  $I_{PEAK}$  and it regulates it at the peak value for the time,  $t_{KEEP}$ , before reducing it to  $I_{HOLD}$ . The solenoid current is regulated at the hold value as long as the EN pin is kept high. The initial current ramp-up time depends on the inductance and resistance of the solenoid. Once EN pin is driven to GND, DRV110 allows the solenoid current to decay to zero.

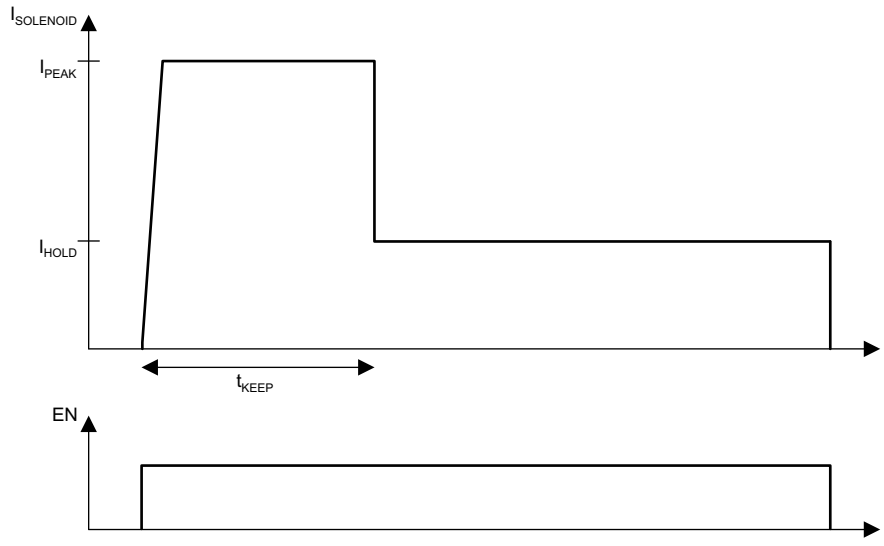

**Figure 2. Typical Current Waveform Through the Solenoid**

#### 7.3.1 Keep Time

The keep time,  $t_{KEEP}$ , is set externally by connecting a capacitor to the KEEP pin. A constant current is sourced from the KEEP pin that is driven into an external capacitor resulting in a linear voltage ramp. When the KEEP pin voltage reaches 100 mV, the current regulation reference voltage,  $V_{REF}$ , is switched from  $V_{PEAK}$  to  $V_{HOLD}$ . The internal current source is switched off, and the capacitor is grounded for discharge. The dependency of  $t_{KEEP}$  from the external capacitor size can be calculated with [Equation 1](#).

$$t_{KEEP} [s] = C_{KEEP} [F] \cdot 10^5 \left[ \frac{s}{F} \right] \quad (1)$$

#### 7.3.2 PWM Current Control

The current control loop regulates, cycle-by-cycle, the solenoid current by sensing voltage at the SENSE pin and controlling the external switching device gate through the OUT pin. During the ON-cycle, the OUT pin voltage is driven and kept high (equal to  $V_{IN}$  voltage) allowing current to flow through the external switch as long as the voltage at the SENSE pin is less than  $V_{REF}$ . As soon as the voltage at the SENSE pin is above  $V_{REF}$ , the OUT pin voltage is immediately driven low and kept low until the next ON-cycle is triggered by the internal PWM clock signal. In the beginning of each ON-cycle, the OUT pin voltage is driven high and kept high for at least the time determined by the minimum PWM signal duty cycle,  $D_{MIN}$ .

Because the current sense is done by comparing the voltage at the SENSE pin to a reference voltage, the DRV110 device acts like a hysteresis controller. When the device acts like a hysteresis controller, it can make the PWM frequency and duty cycle appear uneven for some solenoids (see [Figure 3](#)).

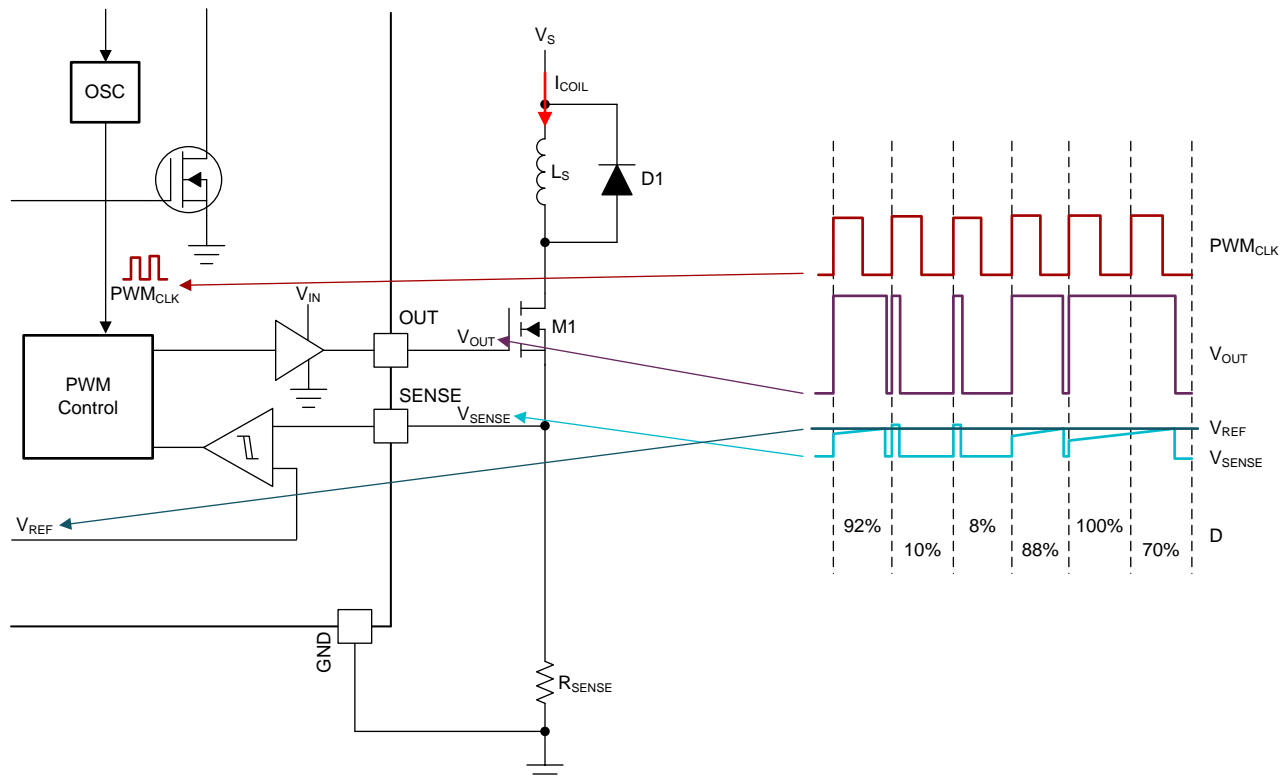
**Feature Description (continued)**

- (1) The DRV110 device measures the voltage at the SENSE node ( $V_{\text{SENSE}}$ ). This voltage is compared against the reference voltage ( $V_{\text{REF}}$ ) each clock cycle. The voltage at the output node ( $V_{\text{OUT}}$ ) becomes low when  $V_{\text{SENSE}} \geq V_{\text{REF}}$ . The duty cycle (D) of the output voltage varies from 8% to 100%. In summary, the SENSE voltage is sampled after each rising edge of the PWM CLK signal ( $\text{PWM}_{\text{CLK}}$ ) and goes low when  $V_{\text{SENSE}} \geq V_{\text{REF}}$  at a minimum duty cycle of 8%.

**Figure 3. DRV110 Current Control with Varying OUT Duty Cycle**

### 7.3.3 Configuring Peak and Hold Currents

$I_{\text{PEAK}}$  and  $I_{\text{HOLD}}$  depend on fixed resistance values  $R_{\text{PEAK}}$  and  $R_{\text{HOLD}}$  as shown in Figure 4. If the PEAK pin or HOLD pin is connected to ground or  $R_{\text{PEAK}}$  or  $R_{\text{HOLD}}$  is less than 43.33 k $\Omega$  (typical), then  $I_{\text{PEAK}}$  is at its default value of 300 mA for  $I_{\text{PEAK}}$  and 50 mA for  $I_{\text{HOLD}}$ .

The  $I_{\text{PEAK}}$  value can alternatively be set by connecting an external resistor to ground from the PEAK pin. For example, if a 60-k $\Omega$  ( $= R_{\text{PEAK}}$ ) resistor is connected between PEAK and GND, and  $R_{\text{SENSE}} = 1 \Omega$ , then the externally set  $I_{\text{PEAK}}$  level will be 900 mA. If  $R_{\text{PEAK}} = 200 \text{ k}\Omega$  and  $R_{\text{SENSE}} = 1 \Omega$ , then the externally set  $I_{\text{PEAK}}$  level will be 300 mA. TI does not recommend using a resistor from 30 k $\Omega$  and 55 k $\Omega$  to avoid the  $I_{\text{PEAK}}$  or  $I_{\text{HOLD}}$  current slipping from the maximum current setting to the default setting.

In case  $R_{\text{SENSE}} = 2 \Omega$  instead of 1  $\Omega$ , then  $I_{\text{PEAK}} = 450 \text{ mA}$  (when  $R_{\text{PEAK}} = 55 \text{ k}\Omega$ ) and  $I_{\text{PEAK}} = 150 \text{ mA}$  (when  $R_{\text{PEAK}} = 200 \text{ k}\Omega$ ). In the 8-pin package, the HOLD reference uses the internal  $V_{\text{REF}}$  setting of 50 mV. In the 14-pin package, external setting of the HOLD current,  $I_{\text{HOLD}}$ , works in the same way as the external setting for  $I_{\text{PEAK}}$  but the current levels are 1/6 of the  $I_{\text{PEAK}}$  levels for the same resistor setting.

External settings for  $I_{\text{PEAK}}$  and  $I_{\text{HOLD}}$  are independent of each other. If  $R_{\text{PEAK}}$  or  $R_{\text{HOLD}}$  is decreased below 33.33 k $\Omega$  (typical value), then the reference is clamped to the internal setting of 300 mV for PEAK and 50 mV for HOLD. Use Equation 2 and Equation 3 to calculate the values for  $I_{\text{PEAK}}$  and  $I_{\text{HOLD}}$  respectively.

The currents and resistor values should be chosen such that the voltage across the sense resistor is more than 30 mV.

### Feature Description (continued)

$$I_{PEAK} = \frac{V_{REF}}{R_{SENSE}} = \frac{1 \Omega \times 900 \text{ mA} \times 66.67 \text{ k}\Omega}{R_{PEAK}} \times \frac{1}{R_{SENSE}}; 66.67 \text{ k}\Omega < R_{PEAK} < 2 \text{ M}\Omega \quad (2)$$

$$I_{HOLD} = \frac{V_{REF}}{R_{SENSE}} = \frac{1 \Omega \times 150 \text{ mA} \times 66.67 \text{ k}\Omega}{R_{HOLD}} \times \frac{1}{R_{SENSE}}; 66.67 \text{ k}\Omega < R_{HOLD} < 333 \text{ k}\Omega \quad (3)$$

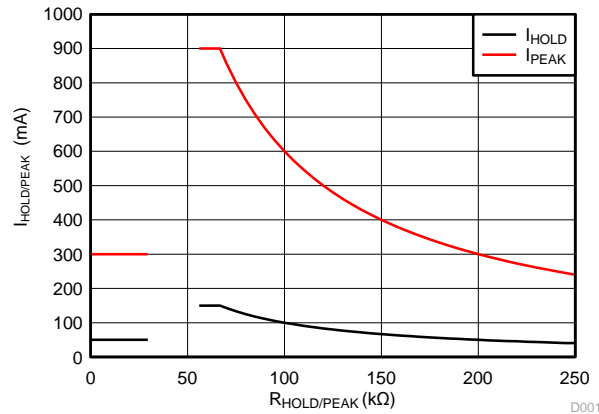

Figure 4. I<sub>PEAK</sub> and I<sub>HOLD</sub> settings for R<sub>SENSE</sub> = 1 Ω

#### 7.3.4 Configuring the PWM Frequency

Frequency of the internal PWM clock signal, PWM<sub>CLK</sub>, that triggers each OUT pin ON-cycle can be adjusted by external resistor, R<sub>OSC</sub>, connected between OSC and GND. Frequency as a function of resistor value is shown in Figure 5. Default frequency is used when OSC is connected to GND directly. Use Equation 4 to calculate the PWM frequency as a function of the external fixed adjustment resistor value (greater than 160 kΩ).

$$f_{PWM} = \frac{60 \text{ kHz}}{R_{OSC}} \times 66.67 \text{ k}\Omega; 160 \text{ k}\Omega < R_{OSC} < 2 \text{ M}\Omega \quad (4)$$

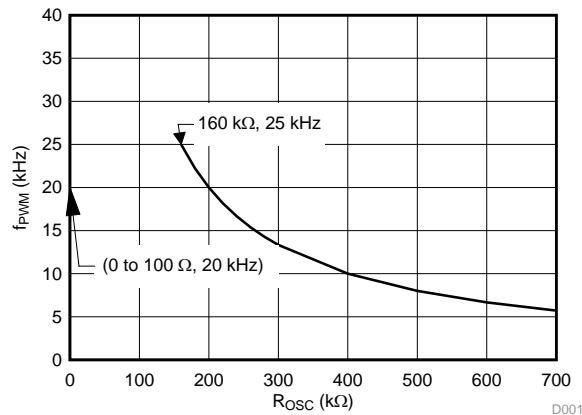

Figure 5. PWM Clock Frequency Setting

#### 7.3.5 Voltage Supply and Integrated Zener Diode

Voltage at the OUT pin, that is the gate voltage of an external switching device, is equal to VIN voltage during the ON-cycle. The voltage is driven to ground during the OFF-cycle. VIN voltages below V<sub>ZENER</sub> can be supplied directly from an external voltage source. Supply voltages of at least 6 V are supported.

**Feature Description (continued)**

The DRV110 is able to regulate VIN voltage from a higher external supply voltage,  $V_S$ , by an internal bypass regulator that replicates the function of an ideal Zener diode. This requires that the supply current is sufficiently limited by an external resistor between  $V_S$  and the VIN pin. An external capacitor connected to the VIN pin is used to store enough energy to charge the external switch gate capacitance at the OUT pin. A range of current limiting resistor sizes ( $R_{S,min}$  and  $R_{S,max}$ ) can be calculated with [Equation 5](#) and [Equation 6](#). This range keeps the VIN current within the recommended operating conditions.

$$R_{S,max} = \frac{V_{S,minDC} - V_{ZENER}}{1 \text{ mA} + I_{Gate,AVE}}$$

where

- $I_{Gate,AVE}$  is the current flowing to the external switch. For a MOSFET,  $I_{Gate,AVE}$  is equal to the external FET gate charge multiplied by  $f_{PWM}$ . (5)

$$R_{S,min} = \frac{V_{S,maxDC} - V_{ZENER}}{3 \text{ mA} + I_{Gate,AVE}} \quad (6)$$

Ideally, the DRV110 device clamps the input voltage to 15 V. For configurations that do not use the EN pin (force the pin high or leave it floating), the DRV110 device clamps at 15 V ( $V_{ZENER} = 15 \text{ V}$ ) across the temperature range of the device. If the EN pin is set to 0, then refer to the values in [Table 1](#) to find the  $V_{ZENER}$  used when calculating the value of  $R_S$ , based on the temperature range of the application. Because the  $V_{ZENER}$  changes when the EN state changes, select a value for  $R_S$  that meets the current requirements at both  $V_{ZENER}$  voltages.

**Table 1.  $V_{ZENER}$  Value**

TEMPERATURE RANGE	ENABLE STATE	$V_{ZENER}$
$-40^\circ\text{C} \leq T_A \leq 125^\circ\text{C}$	1	15 V
$-40^\circ\text{C} \leq T_A \leq 35^\circ\text{C}$	0	15 V
$-40^\circ\text{C} \leq T_A \leq 45^\circ\text{C}$	0	14.2 V
$-40^\circ\text{C} \leq T_A \leq 55^\circ\text{C}$	0	13.9 V
$-40^\circ\text{C} \leq T_A \leq 65^\circ\text{C}$	0	13.5 V
$-40^\circ\text{C} \leq T_A \leq 75^\circ\text{C}$	0	13.1 V
$-40^\circ\text{C} \leq T_A \leq 85^\circ\text{C}$	0	12.7 V
$-40^\circ\text{C} \leq T_A \leq 95^\circ\text{C}$	0	12.3 V
$-40^\circ\text{C} \leq T_A \leq 105^\circ\text{C}$	0	12 V
$-40^\circ\text{C} \leq T_A \leq 115^\circ\text{C}$	0	11.4 V
$-40^\circ\text{C} \leq T_A \leq 125^\circ\text{C}$	0	11 V

The open-drain pulldown path at the STATUS pin is deactivated if the undervoltage lockout or thermal shutdown blocks have triggered or if the EN pin is low.

## 7.4 Device Functional Modes

### 7.4.1 Normal Mode

The DRV110 transitions through three different states in normal mode:

**OFF state** In the OFF state, the EN pin is low and the PWM output is off.

**PEAK state** The PEAK state begins when the EN pin is set high, and ends when the  $t_{KEEP}$  time has been reached. During this state, the PWM operates to reach the  $I_{PEAK}$  current set by the  $R_{PEAK}$  resistor.

**HOLD state** In the HOLD state, the  $t_{KEEP}$  time has been reached, and the PWM continues to operate but at the  $I_{HOLD}$  level. This continues until the EN pin is set low again and the PWM turns off.

### 7.4.2 Shutdown

The DRV110 turns off the gate driver in undervoltage lockout ( $V_{IN} < 4.6\text{ V}$ ) or thermal shutdown ( $T_J > 160^\circ\text{C}$ ). If temperature shutdown is activated, the DRV110 resumes operation when the junction temperature is below  $140^\circ\text{C}$ . The shutdown conditions are expressed by the STATUS pin going to the high-impedance state. A pullup resistor can be connected to the STATUS pin so these conditions may be observed by a microcontroller. [Table 2](#) provides an explanation of this operation.

**Table 2. Shutdown Operation**

CONDITIONS			OUTPUT PINS	
EN	UVLO	TSD	STATUS	OUT
0	X	X	Hi-Z	LOW
1	0	0	Pulled down	HIGH or PWM
1	X	1	Hi-Z	LOW
1	1	X	Hi-Z	LOW

## 8 Application and Implementation

### NOTE

Information in the following applications sections is not part of the TI component specification, and TI does not warrant its accuracy or completeness. TI's customers are responsible for determining suitability of components for their purposes. Customers should validate and test their design implementation to confirm system functionality.

### 8.1 Application Information

The DRV110 device is designed to operate a solenoid valve or relay. For detailed information on using the DRV110 with 230 V AC solenoids, see [Current Controlled Driver for 230V AC Solenoids Reference Design](#). A typical DC input design will be outlined in [Typical Application](#). Approximate resistor and capacitor values for the peak current, hold current, sense, and keep time will be derived for a sample application.

### 8.2 Typical Application

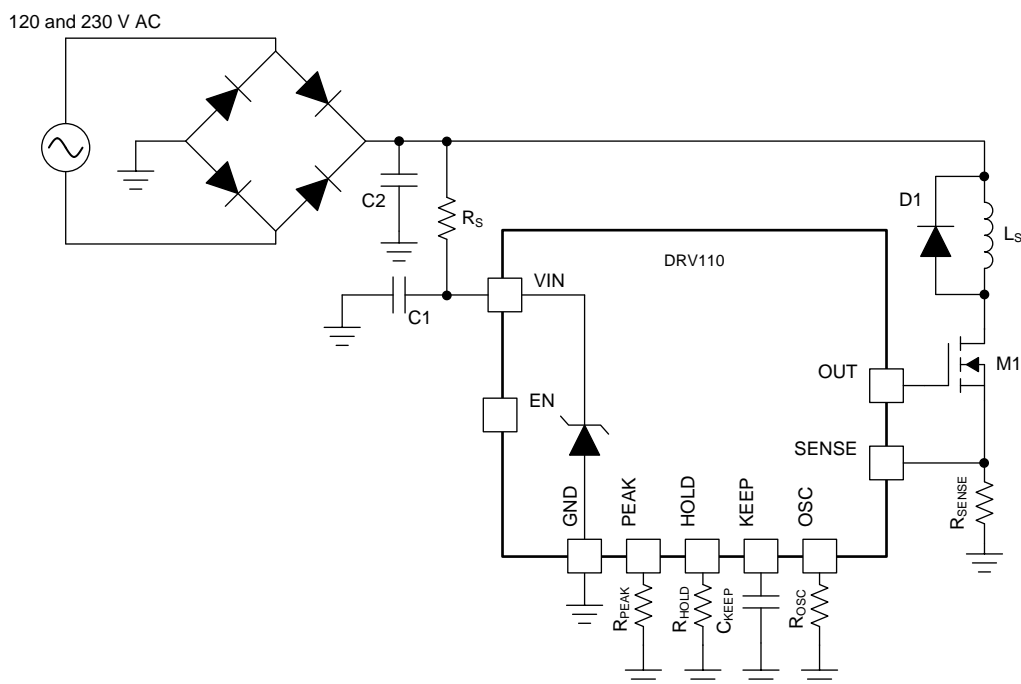

Copyright © 2016, Texas Instruments Incorporated

**Figure 6. DRV110 Powered by a Rectified AC Power Source**

## Typical Application (continued)

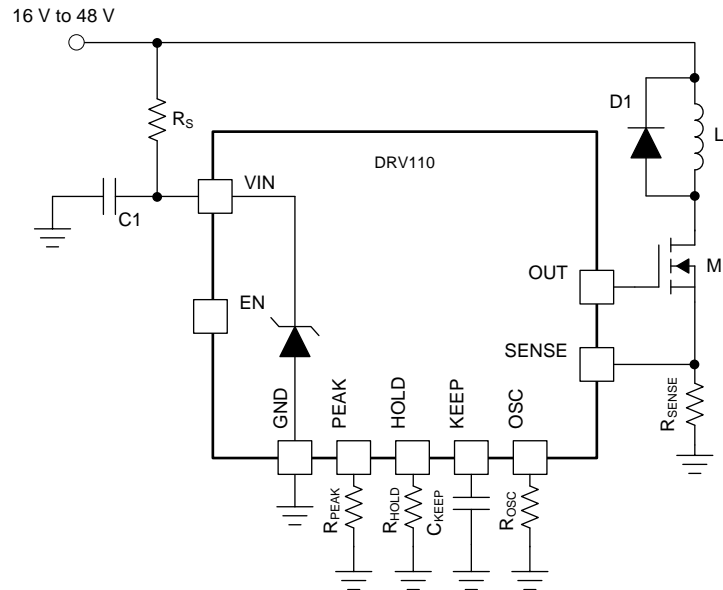

Copyright © 2016, Texas Instruments Incorporated

Figure 7. DRV110 Powered by a DC Power Source Greater than 15 V

### 8.2.1 Design Requirements

The key elements to identify here are the system input voltage, peak current, hold current, and peak keep time values required for the solenoid or relay being used. With these values, approximate  $R_S$ ,  $R_{PEAK}$ ,  $R_{HOLD}$  (for 14-pin package),  $C_{KEEP}$ , and  $R_{SENSE}$  values can be determined and the proper FET and diode can be identified.  $R_{OSC}$  can be varied in order to tune the circuit to the chosen solenoid or relay.

### 8.2.2 Detailed Design Procedure

#### 8.2.2.1 Current Limiting Resistor Selection

The temperature range, input voltage, and enable state must be considered when selecting the current limiting resistor. These values must be considered because the Zener clamping voltage of the DRV110 device starts dropping from its ideal 15 V at temperatures greater than 45°C when the EN pin is pulled low. Applications that leave the EN pin floating or pulled high at all times only require a current-limiting resistor when the input voltage is greater than 15 V across all temperature.

While using a current-limiting resistor is not required when the supply voltage ( $V_S$ ) is less than the Zener clamping voltage,  $V_{ZENER}$ , TI recommends populating a small resistor in case of possible input voltage transients during operation. At the very least, TI recommends placing a resistor footprint jumped by a 0-Ω resistor. Table 3 lists recommended resistor values for voltages close to  $V_{ZENER}$  and common voltages greater than  $V_{ZENER}$  for different enable states.

**Table 3. Recommended Resistor Values**  
 $-40^{\circ}\text{C} \leq T_A \leq 125^{\circ}\text{C}$ 

SUPPLY VOLTAGE	RECOMMENDED CURRENT-LIMITING RESISTOR
<b>EN Pulled High or Floating</b>	
< 15 V	500 $\Omega$
24 V	9 k $\Omega$
48 V	33 k $\Omega$
110 V to 120 V	100 k $\Omega$
220 V to 240 V	200 k $\Omega$
<b>EN Toggled Between 0 and 1</b>	
10 V	510 $\Omega$
11 V	510 $\Omega$
12 V	1 k $\Omega$
13 V	2 k $\Omega$
14 V	3 k $\Omega$
15 V	3.9 k $\Omega$
24 V	13 k $\Omega$
48 V	36 k $\Omega$
110 V to 120 V	100 k $\Omega$
220 V to 240 V	200 k $\Omega$

### 8.2.2.2 Passive Component Selection

With the selected peak current, hold current, and peak keep time values, the values of  $R_{\text{PEAK}}$ ,  $R_{\text{HOLD}}$  (for 14-pin package),  $C_{\text{KEEP}}$ , and  $R_{\text{SENSE}}$  can be determined. [Table 4](#) lists the example values and results from calculation.

**Table 4. Example Application Values When  $R_{\text{SENSE}} = 1 \Omega$** 

VARIABLE	VALUE	14-PIN VALUES	8-PIN VALUES	CALCULATED FROM
Peak current	150 mA	$R_{\text{PEAK}} = 400 \text{ k}\Omega$	$R_{\text{PEAK}} = 400 \text{ k}\Omega$	<a href="#">Equation 2</a>
Hold current	50 mA	$R_{\text{HOLD}} = 200 \text{ k}\Omega$ or connect HOLD to ground	Default	<a href="#">Equation 3</a>
Keep time	100 ms	$C_{\text{KEEP}} = 1 \mu\text{F}$	$C_{\text{KEEP}} = 1 \mu\text{F}$	<a href="#">Equation 1</a>
PWM frequency	20 kHz	$R_{\text{OSC}} = \text{Shorted to ground}$	$R_{\text{OSC}} = \text{Shorted to ground}$	<a href="#">Equation 4</a>

Use [Equation 2](#) and [Equation 3](#) to calculate the values of the  $R_{\text{PEAK}}$  resistor and  $R_{\text{HOLD}}$  (if applicable) resistor. For the sample values, the  $R_{\text{PEAK}}$  resistor is set to 400 k $\Omega$  and the  $R_{\text{HOLD}}$  resistor is shorted to GND. TI recommends using a 0- $\Omega$  resistor for prototyping in case changes to this value are desired.

Next, select the value of the  $C_{\text{KEEP}}$  capacitor based on [Equation 1](#). For the sample value, the  $C_{\text{KEEP}}$  capacitor is set to 1  $\mu\text{F}$ . The  $R_{\text{OSC}}$  resistor is initially be shorted to GND, but a 0- $\Omega$  resistor is also recommended for prototyping. Additionally, a low-pass filter on the SENSE line can be added in a high-noise environment and is recommended for prototyping. The typical value for the low pass filter resistor is 1 k $\Omega$  and the typical value for the filter capacitor is 100 pF.

The value of sense resistor can be selected based on the preference of the designer. The only restriction is that the voltage across the sense resistor (found by the  $R_{\text{SENSE}}$  resistance times the  $I_{\text{HOLD}}$  current) must be greater than 30 mV for reliable operation.

The external FET and current recirculation diode must be selected based on the current values defined in [Table 4](#) and the supply voltage. The current recirculation diode should be a fast recovery diode.

### 8.2.3 Application Curve

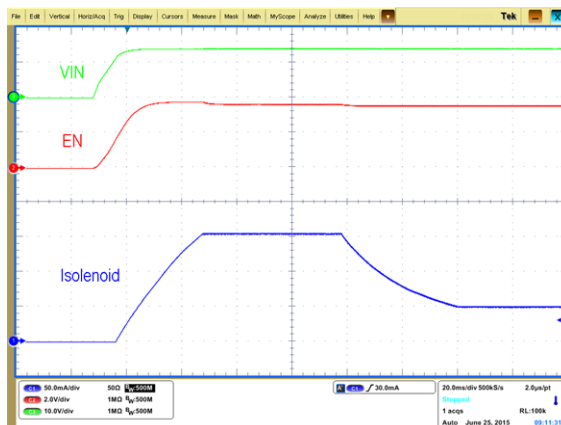

$$\begin{array}{lll}
 R_{OSC} = 0 \Omega & R_{PEAK} = 400 \text{ k}\Omega & R_{HOLD} = 0 \Omega \\
 R_{SENSE} = 1 \Omega & C_{KEEP} = 1 \mu\text{F} & L_{ind} = 1 \text{ H} \\
 R_{ind} = 50 \Omega & \text{Measured on the EVM} & 
 \end{array}$$

Figure 8.  $I_{SOLENOID}$ , EN, and  $V_{IN}$  vs Time

## 9 Power Supply Recommendations

The input supply range must be at least 6 V, and needs a current-limiting resistor above  $V_{ZENER}$ . An input capacitor of 4.7  $\mu\text{F}$  (typical) is required as well.  $I_Q$  max is 3 mA, but additional current will be required to operate the solenoid or relay.

## 10 Layout

### 10.1 Layout Guidelines

Routing for the SENSE pin should be careful to avoid noise sources. Routing for the output node and sense node should be minimized. The trace for the solenoid or relay current should be wide in order to prevent any unexpected voltage drop.



## 11 器件和文档支持

### 11.1 文档支持

#### 11.1.1 相关文档

如需相关文档，请参阅：

- 德州仪器 (TI)，《用于具有柱塞故障检测功能的 24V 直流电磁阀的电流控制驱动器》参考设计
- 德州仪器 (TI)，《用于 230V 交流电磁阀的电流控制驱动器参考设计》
- 德州仪器 (TI)，《DRV110 和 DRV120 评估模块 (EVM)》用户指南

### 11.2 接收文档更新通知

如需接收文档更新通知，请访问 [www.ti.com.cn](http://www.ti.com.cn) 网站上的器件产品文件夹。请单击右上角的提醒我进行注册，即可每周接收产品信息更改摘要。"有关更改的详细信息、请查阅已修订文档中包含的修订历史记录。

### 11.3 社区资源

下列链接提供到 TI 社区资源的连接。链接的内容由各个分销商“按照原样”提供。这些内容并不构成 TI 技术规范，并且不一定反映 TI 的观点；请参阅 TI 的《使用条款》。

**TI E2E™ 在线社区** *TI 的工程师对工程师 (E2E) 社区*。此社区的创建目的在于促进工程师之间的协作。在 [e2e.ti.com](http://e2e.ti.com) 中，您可以咨询问题、分享知识、拓展思路并与同行工程师一道帮助解决问题。

**设计支持** *TI 参考设计支持* 可帮助您快速查找有帮助的 E2E 论坛、设计支持工具以及技术支持的联系信息。

### 11.4 商标

E2E is a trademark of Texas Instruments.

All other trademarks are the property of their respective owners.

### 11.5 静电放电警告



ESD 可能会损坏该集成电路。德州仪器 (TI) 建议通过适当的预防措施处理所有集成电路。如果不遵守正确的处理措施和安装程序，可能会损坏集成电路。

ESD 的损坏小至导致微小的性能降级，大至整个器件故障。精密的集成电路可能更容易受到损坏，这是因为非常细微的参数更改都可能会导致器件与其发布的规格不相符。

### 11.6 Glossary

[SLYZ022](#) — *TI Glossary*.

This glossary lists and explains terms, acronyms, and definitions.

## 12 机械、封装和可订购信息

以下页面包含机械、封装和可订购信息。这些信息是指定器件的最新可用数据。数据如有变更，恕不另行通知，且不会对此文档进行修订。如需获取此数据表的浏览器版本，请查阅左侧的导航栏。

**PACKAGING INFORMATION**

Orderable Device	Status (1)	Package Type	Package Drawing	Pins	Package Qty	Eco Plan (2)	Lead finish/ Ball material (6)	MSL Peak Temp (3)	Op Temp (°C)	Device Marking (4/5)	Samples
DRV110APWR	ACTIVE	TSSOP	PW	14	2000	RoHS & Green	NIPDAU	Level-2-260C-1 YEAR	-40 to 125	110A	<a href="#">Samples</a>
DRV110PWR	ACTIVE	TSSOP	PW	8	2000	RoHS & Green	NIPDAU	Level-2-260C-1 YEAR	-40 to 125	110	<a href="#">Samples</a>

(1) The marketing status values are defined as follows:

**ACTIVE:** Product device recommended for new designs.

**LIFEBUY:** TI has announced that the device will be discontinued, and a lifetime-buy period is in effect.

**NRND:** Not recommended for new designs. Device is in production to support existing customers, but TI does not recommend using this part in a new design.

**PREVIEW:** Device has been announced but is not in production. Samples may or may not be available.

**OBSELETE:** TI has discontinued the production of the device.

(2) **RoHS:** TI defines "RoHS" to mean semiconductor products that are compliant with the current EU RoHS requirements for all 10 RoHS substances, including the requirement that RoHS substance do not exceed 0.1% by weight in homogeneous materials. Where designed to be soldered at high temperatures, "RoHS" products are suitable for use in specified lead-free processes. TI may reference these types of products as "Pb-Free".

**RoHS Exempt:** TI defines "RoHS Exempt" to mean products that contain lead but are compliant with EU RoHS pursuant to a specific EU RoHS exemption.

**Green:** TI defines "Green" to mean the content of Chlorine (Cl) and Bromine (Br) based flame retardants meet JS709B low halogen requirements of <=1000ppm threshold. Antimony trioxide based flame retardants must also meet the <=1000ppm threshold requirement.

(3) MSL, Peak Temp. - The Moisture Sensitivity Level rating according to the JEDEC industry standard classifications, and peak solder temperature.

(4) There may be additional marking, which relates to the logo, the lot trace code information, or the environmental category on the device.

(5) Multiple Device Markings will be inside parentheses. Only one Device Marking contained in parentheses and separated by a "~" will appear on a device. If a line is indented then it is a continuation of the previous line and the two combined represent the entire Device Marking for that device.

(6) Lead finish/Ball material - Orderable Devices may have multiple material finish options. Finish options are separated by a vertical ruled line. Lead finish/Ball material values may wrap to two lines if the finish value exceeds the maximum column width.

**Important Information and Disclaimer:**The information provided on this page represents TI's knowledge and belief as of the date that it is provided. TI bases its knowledge and belief on information provided by third parties, and makes no representation or warranty as to the accuracy of such information. Efforts are underway to better integrate information from third parties. TI has taken and continues to take reasonable steps to provide representative and accurate information but may not have conducted destructive testing or chemical analysis on incoming materials and chemicals. TI and TI suppliers consider certain information to be proprietary, and thus CAS numbers and other limited information may not be available for release.

In no event shall TI's liability arising out of such information exceed the total purchase price of the TI part(s) at issue in this document sold by TI to Customer on an annual basis.

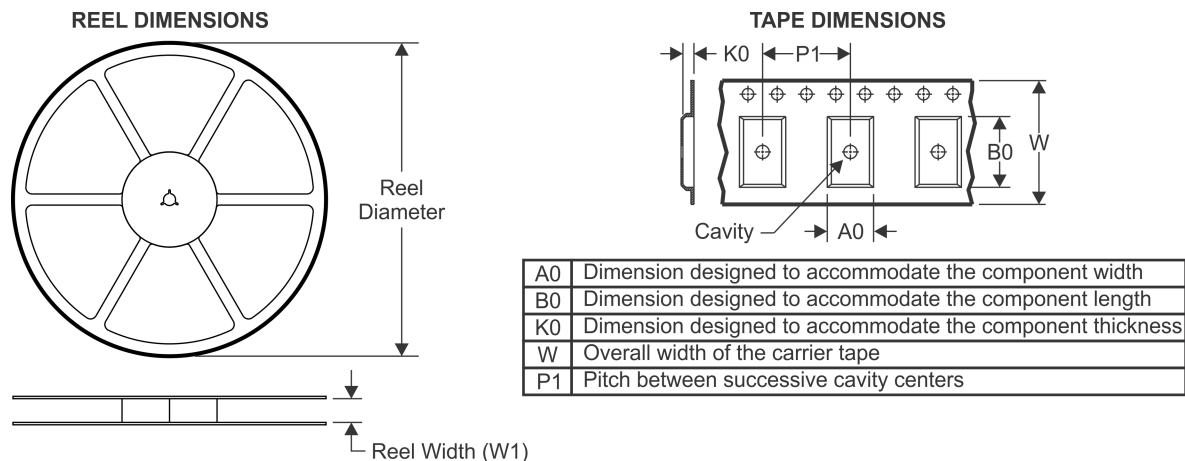

**TAPE AND REEL INFORMATION**

**QUADRANT ASSIGNMENTS FOR PIN 1 ORIENTATION IN TAPE**

\*All dimensions are nominal

Device	Package Type	Package Drawing	Pins	SPQ	Reel Diameter (mm)	Reel Width W1 (mm)	A0 (mm)	B0 (mm)	K0 (mm)	P1 (mm)	W (mm)	Pin1 Quadrant
DRV110APWR	TSSOP	PW	14	2000	330.0	12.4	6.9	5.6	1.6	8.0	12.0	Q1
DRV110PWR	TSSOP	PW	8	2000	330.0	12.4	7.0	3.6	1.6	8.0	12.0	Q1

**TAPE AND REEL BOX DIMENSIONS**

\*All dimensions are nominal

Device	Package Type	Package Drawing	Pins	SPQ	Length (mm)	Width (mm)	Height (mm)
DRV110APWR	TSSOP	PW	14	2000	853.0	449.0	35.0
DRV110PWR	TSSOP	PW	8	2000	853.0	449.0	35.0



# MECHANICAL DATA

PW (R-PDSO-G14)

PLASTIC SMALL OUTLINE



4040064-3/G 02/11

- NOTES:
- A. All linear dimensions are in millimeters. Dimensioning and tolerancing per ASME Y14.5M-1994.
  - B. This drawing is subject to change without notice.
  -  C. Body length does not include mold flash, protrusions, or gate burrs. Mold flash, protrusions, or gate burrs shall not exceed 0,15 each side.
  -  D. Body width does not include interlead flash. Interlead flash shall not exceed 0,25 each side.
  - E. Falls within JEDEC MO-153

PW (R-PDSO-G14)

PLASTIC SMALL OUTLINE



4211284-2/G 08/15

- NOTES:
- All linear dimensions are in millimeters.
  - This drawing is subject to change without notice.
  - Publication IPC-7351 is recommended for alternate designs.
  - Laser cutting apertures with trapezoidal walls and also rounding corners will offer better paste release. Customers should contact their board assembly site for stencil design recommendations. Refer to IPC-7525 for other stencil recommendations.
  - Customers should contact their board fabrication site for solder mask tolerances between and around signal pads.

PW0008A



PACKAGE OUTLINE

TSSOP - 1.2 mm max height

SMALL OUTLINE PACKAGE

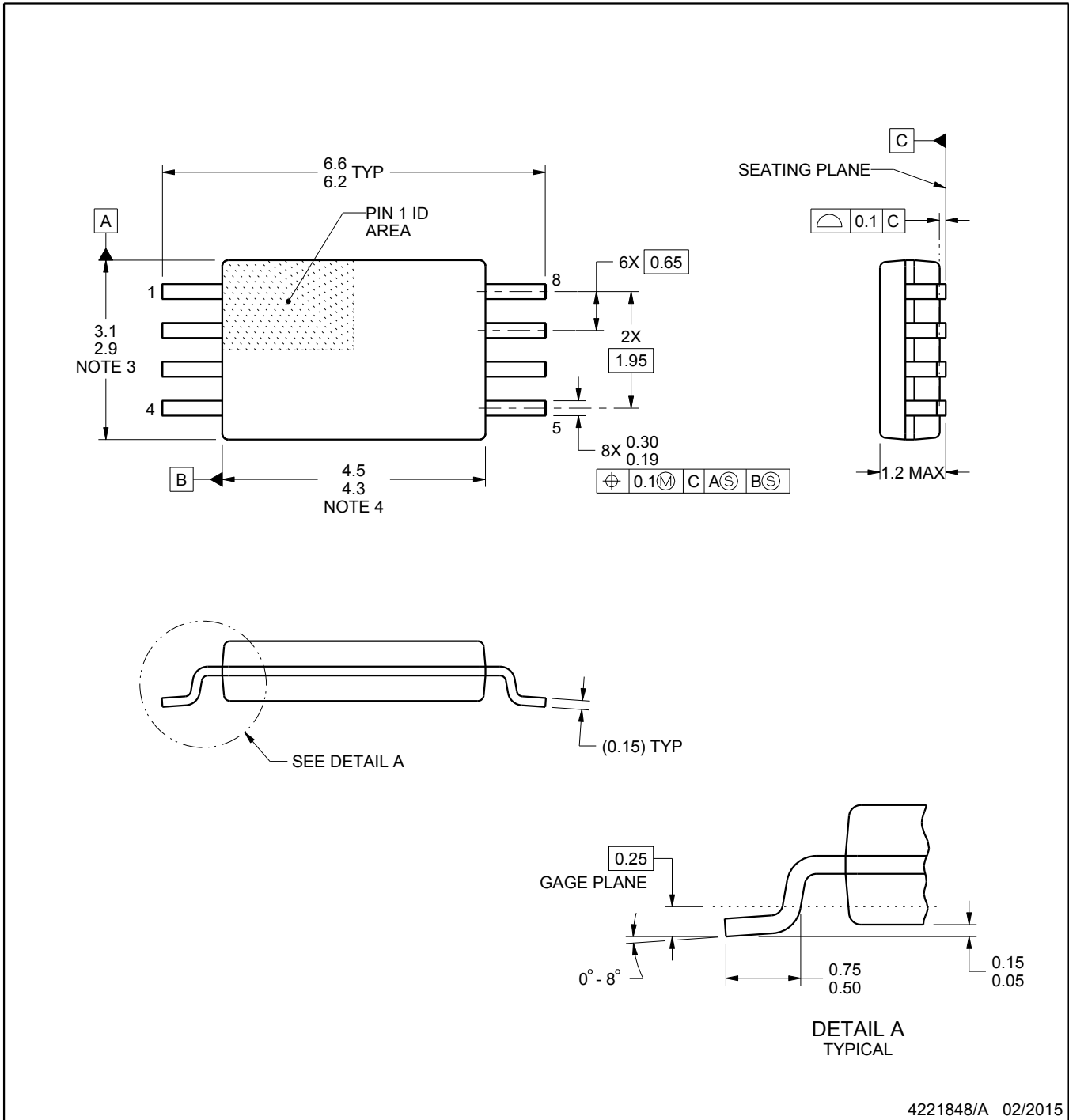

4221848/A 02/2015

NOTES:

1. All linear dimensions are in millimeters. Any dimensions in parenthesis are for reference only. Dimensioning and tolerancing per ASME Y14.5M.
2. This drawing is subject to change without notice.
3. This dimension does not include mold flash, protrusions, or gate burrs. Mold flash, protrusions, or gate burrs shall not exceed 0.15 mm per side.
4. This dimension does not include interlead flash. Interlead flash shall not exceed 0.25 mm per side.
5. Reference JEDEC registration MO-153, variation AA.

# EXAMPLE BOARD LAYOUT

PW0008A

TSSOP - 1.2 mm max height

SMALL OUTLINE PACKAGE



LAND PATTERN EXAMPLE  
SCALE:10X



SOLDER MASK DETAILS  
NOT TO SCALE

4221848/A 02/2015

NOTES: (continued)

- 6. Publication IPC-7351 may have alternate designs.
- 7. Solder mask tolerances between and around signal pads can vary based on board fabrication site.

# EXAMPLE STENCIL DESIGN

PW0008A

TSSOP - 1.2 mm max height

SMALL OUTLINE PACKAGE



SOLDER PASTE EXAMPLE  
BASED ON 0.125 mm THICK STENCIL  
SCALE:10X

4221848/A 02/2015

NOTES: (continued)

8. Laser cutting apertures with trapezoidal walls and rounded corners may offer better paste release. IPC-7525 may have alternate design recommendations.
9. Board assembly site may have different recommendations for stencil design.

## 重要声明和免责声明

TI“按原样”提供技术和可靠性数据（包括数据表）、设计资源（包括参考设计）、应用或其他设计建议、网络工具、安全信息和其他资源，不保证没有瑕疵且不做任何明示或暗示的担保，包括但不限于对适销性、某特定用途方面的适用性或不侵犯任何第三方知识产权的暗示担保。

这些资源可供使用 TI 产品进行设计的熟练开发人员使用。您将自行承担以下全部责任：(1) 针对您的应用选择合适的 TI 产品，(2) 设计、验证并测试您的应用，(3) 确保您的应用满足相应标准以及任何其他功能安全、信息安全、监管或其他要求。

这些资源如有变更，恕不另行通知。TI 授权您仅可将这些资源用于研发本资源所述的 TI 产品的应用。严禁对这些资源进行其他复制或展示。您无权使用任何其他 TI 知识产权或任何第三方知识产权。您应全额赔偿因在这些资源的使用中对 TI 及其代表造成的任何索赔、损害、成本、损失和债务，TI 对此概不负责。

TI 提供的产品受 [TI 的销售条款](#) 或 [ti.com](#) 上其他适用条款/TI 产品随附的其他适用条款的约束。TI 提供这些资源并不会扩展或以其他方式更改 TI 针对 TI 产品发布的适用的担保或担保免责声明。

TI 反对并拒绝您可能提出的任何其他或不同的条款。

邮寄地址：Texas Instruments, Post Office Box 655303, Dallas, Texas 75265

Copyright © 2022，德州仪器 (TI) 公司