

SN74LV1T00 单电源 2 输入正与非门 CMOS 逻辑电平转换器

1 特性

- 电压为 5.0/3.3/2.5/1.8V 的单电源电压转换器 V_{CC}
- 1.8V 至 5.5V 的工作电压范围
- 上行转换
 - 1.8V V_{CC} 时, 1.2V⁽¹⁾ 至 1.8V
 - 2.5V V_{CC} 时, 1.5V⁽¹⁾ 至 2.5V
 - 3.3V V_{CC} 时, 1.8V⁽¹⁾ 至 3.3V
 - 5.0V V_{CC} 时, 3.3V 至 5.0V
- 下行转换
 - 1.8V V_{CC} 时, 3.3V 至 1.8V
 - 2.5V V_{CC} 时, 3.3V 至 2.5V
 - 3.3V V_{CC} 时, 5.0V 至 3.3V
- 逻辑输出以电源 V_{CC} 为基准
- 输出驱动
 - 5V 时, 8mA 的输出驱动
 - 3.3V 时, 7mA 的输出驱动
 - 1.8V 时, 3mA 的输出驱动
- 3.3V V_{CC} 时, 频率高达 50MHz
- 输入引脚可耐受 5V 电压
- -40°C 至 125°C 工作温度范围
- 采用无铅封装: SC-70 (DCK)
 - 2mm x 2.1mm x 0.65mm
- 锁断性能超过 250mA
符合 JESD 17 规范
- 静电放电 (ESD) 性能测试符合 JESD 22 规范
 - 2000V 人体模型 (A114-B, II 类)
 - 200V 机器模型 (A115-A)
 - 1000V 充电器件模型 (C101)
- 支持标准逻辑引出脚
- 与 AUP1G 和 LVC1G 系列兼容的 CMOS 输出 B

(1) 请参考更低 V_{CC} 条件下的 V_{IH}/V_{IL} 和输出驱动。

2 应用范围

- 工业用控制器
- 电信
- 便携式应用
- 服务器
- 台式机和笔记本电脑
- 汽车

3 说明

SN74LV1T00 是一款具有较宽电压范围的低压 CMOS 门逻辑电路, 用于工业、便携、电信和汽车应用。输出电平以电源电压为基准, 并且能够支持 1.8V/2.5V/3.3V/5V CMOS 电平。

采用了更低阈值电路来设计此输入, 以便匹配 $V_{CC} = 3.3V$ 时的 1.8V 输入逻辑, 并且可被用于 1.8V 至 3.3V 电平上行转换。此外, 5V 容限输入引脚可实现下行转换 (例如, $V_{CC} = 2.5V$ 时的 3.3V 至 2.5V 输出转换)。1.8V 至 5.5V 的宽 V_{CC} 范围可使所需输出电平的生成接至控制器或处理器。

SN74LV1T00 被设计成具有 8mA 的电流驱动能力, 以减少由高驱动输出导致的线路反射、过冲和下冲。

器件信息

订货编号	封装	封装尺寸
SN74LV1T00DBVR	小外形尺寸晶体管封装 (SOT)-23 (5)	2.90mm x 1.60mm
SN74LV1T00DCKR	SC70 (5)	2.00mm x 1.25mm

DCK 或 DBV 封装
(顶视图)

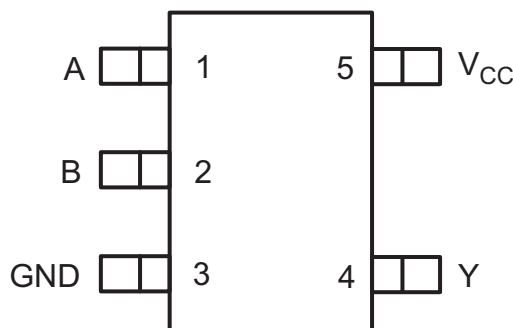

目录

1	特性	1	4.6	OPERATING CHARACTERISTICS	7
2	应用范围	1	5	Parameter Measurement Information	8
3	说明	1	5.1	More Product Selection	8
4	修订历史记录	2	6	器件和文档支持	9
4.1	Typical Design Examples	5	6.1	Trademarks	9
4.2	Absolute Maximum Ratings	5	6.2	Electrostatic Discharge Caution	9
4.3	Recommended Operating Conditions	6	6.3	Glossary	9
4.4	Electrical Characteristics	6	7	机械封装和可订购信息	9
4.5	Switching Characteristics	7			

4 修订历史记录

NOTE: Page numbers for previous revisions may differ from page numbers in the current version.

Changes from Original (September 2013) to Revision A

Page

•	已更新文档格式。	1
•	Updated V_{CC} values for V_{IH} parameter in the ELECTRICAL CHARACTERISTICS table.	6

Changes from Revision A (September 2013) to Revision B

Page

Function Table

INPUT (Lower Level Input)		OUTPUT (V _{CC} CMOS)
A	B	Y
H	H	L
L	X	H
X	L	H
SUPPLY V_{CC} = 3.3V		
A	B	Y
V _{IH} (min) = 1.35 V		V _{OH} (min) = 2.9 V
V _{IL} (max) = 0.8 V		V _{OL} (max) = 0.2 V

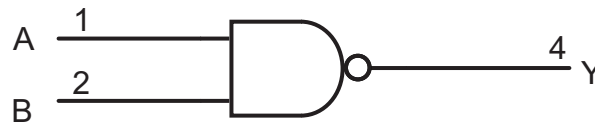

Figure 1. Logic Diagram (NAND Gate)

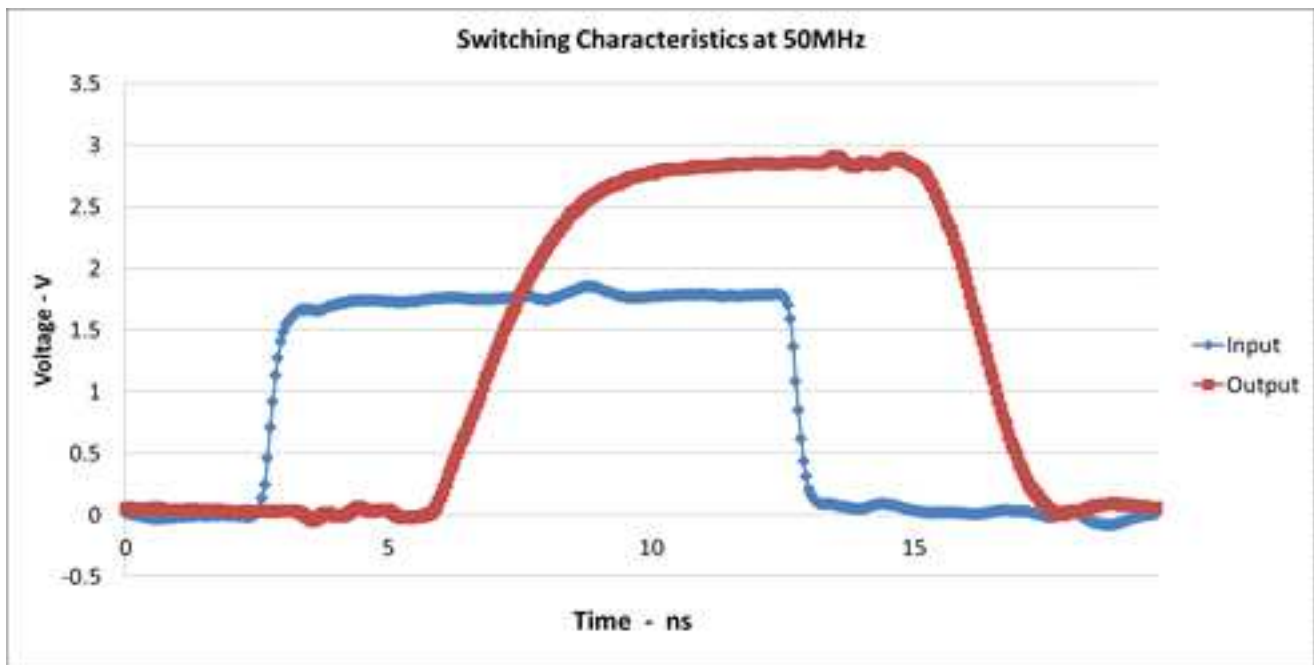

Figure 2. Excellent Signal Integrity (1.8V to 3.3V at 3.3V V_{CC})

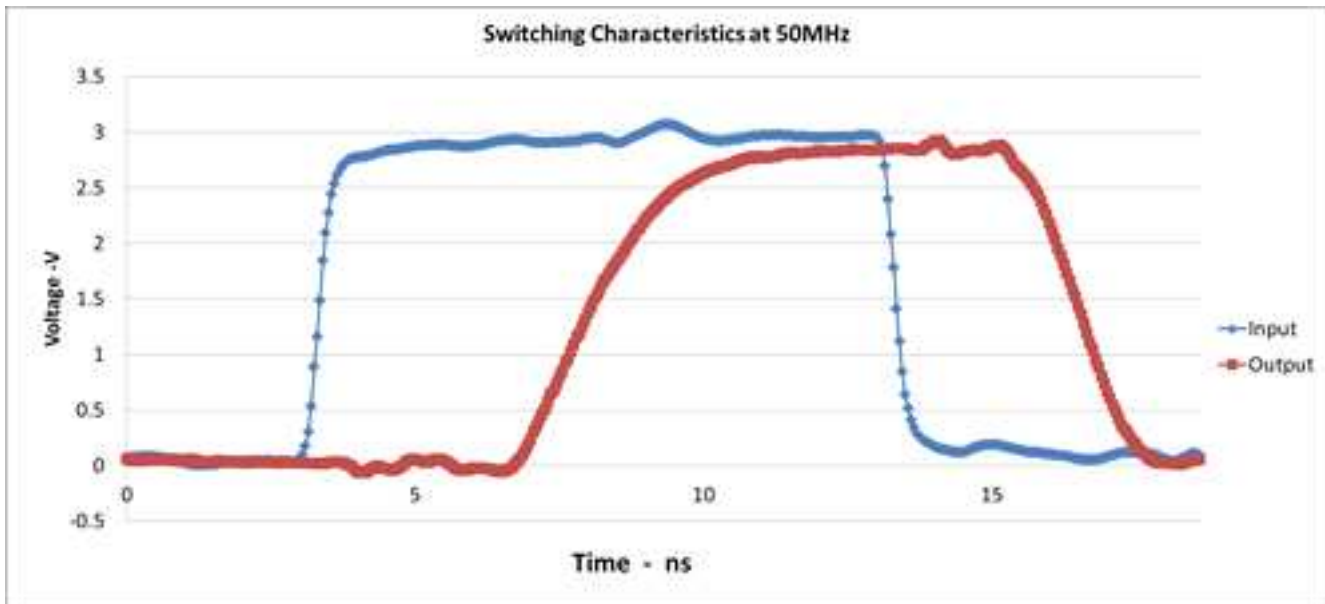

Figure 3. Excellent Signal Integrity (3.3V to 3.3V at 3.3V V_{CC})

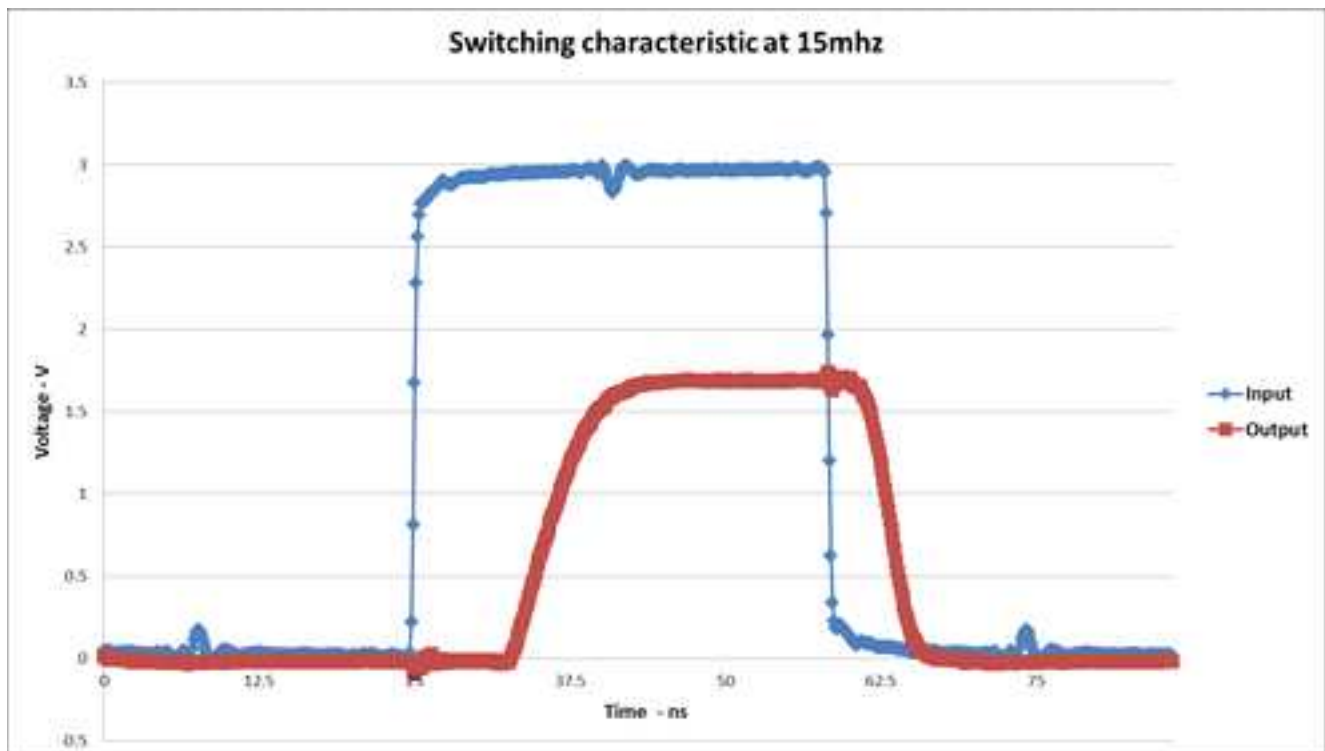

Figure 4. Excellent Signal Integrity (3.3V to 1.8V at 1.8V V_{CC})

4.1 Typical Design Examples

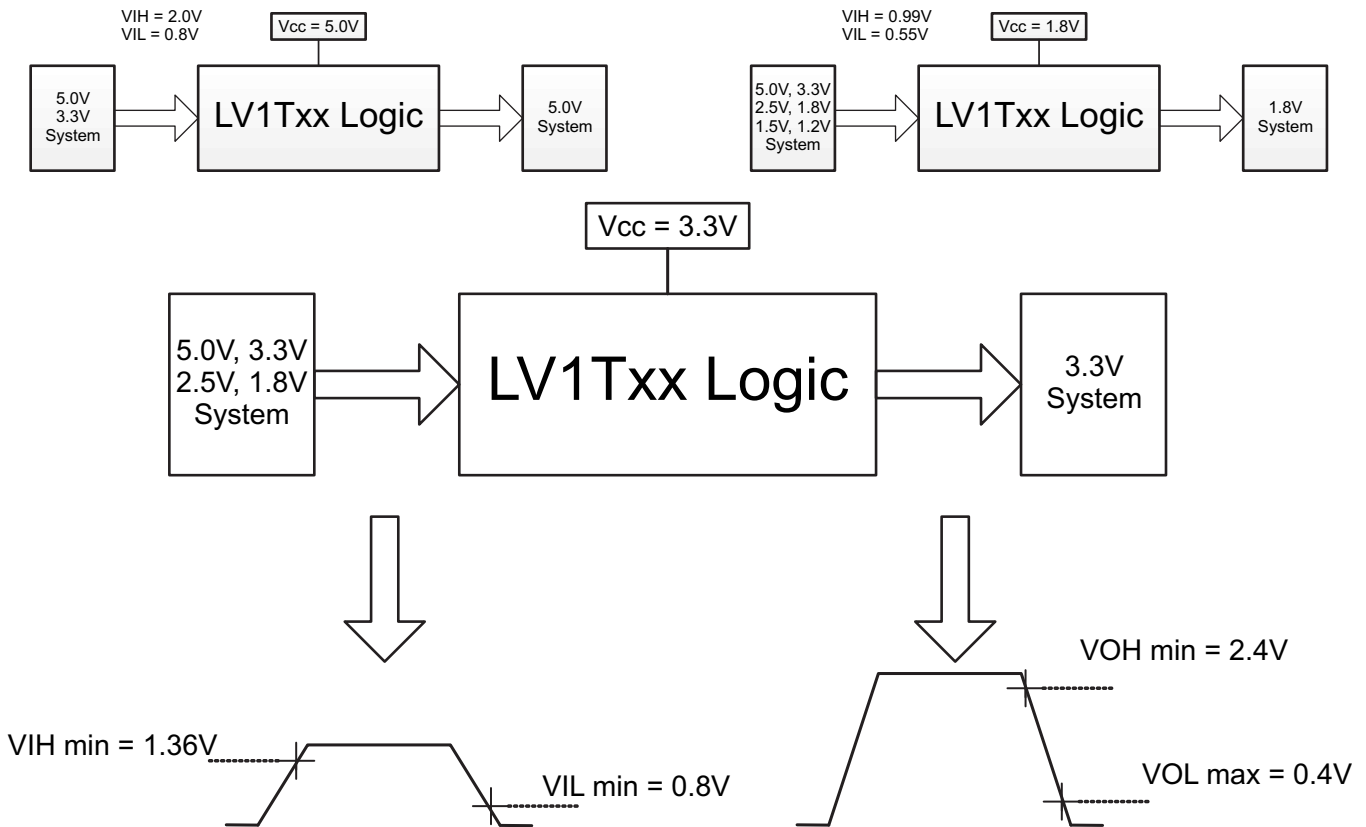

Figure 5. Switching Thresholds for 1.8-V to 3.3-V Translation

4.2 Absolute Maximum Ratings⁽¹⁾

over operating free-air temperature range (unless otherwise noted)

		MIN	MAX	UNIT
V _{CC}	Supply voltage range	-0.5	7.0	V
V _I	Input voltage range ⁽²⁾	-0.5	7.0	V
V _O	Voltage range applied to any output in the high-impedance or power-off state ⁽²⁾	-0.5	4.6	V
	Voltage range applied to any output in the high or low state ⁽²⁾	-0.5	V _{CC} + 0.5	V
I _{IK}	Input clamp current	V _I < 0		-20 mA
I _{OK}	Output clamp current	V _O < 0 or V _O > V _{CC}		±20 mA
I _O	Continuous output current			±25 mA
	Continuous current through VCC or GND			±50 mA
θ _{JA}	Package thermal impedance ⁽³⁾	DBV package		206
		DCK package		252 °C/W
T _{stg}	Storage temperature range	-65	150	°C

(1) Stresses beyond those listed under "absolute maximum ratings" may cause permanent damage to the device. These are stress ratings only, and functional operation of the device at these or any other conditions beyond those indicated under "recommended operating conditions" is not implied. Exposure to absolute-maximum-rated conditions for extended periods may affect device reliability.

(2) The input negative-voltage and output voltage ratings may be exceeded if the input and output current ratings are observed.

(3) The package thermal impedance is calculated in accordance with JESD 51-7.

4.3 Recommended Operating Conditions⁽¹⁾

over operating free-air temperature range (unless otherwise noted)

		MIN	MAX	UNIT	
V_{CC}	Supply voltage	1.6	5.5	V	
V_I	Input voltage	0	5.5	V	
V_O	Output voltage	0	V_{CC}	V	
I_{OH}	High-level output current	$V_{CC} = 1.8\text{ V}$		-3	mA
		$V_{CC} = 2.5\text{ V}$		-5	
		$V_{CC} = 3.3\text{ V}$		-7	
		$V_{CC} = 5.0\text{ V}$		-8	
I_{OL}	Low-level output current	$V_{CC} = 1.8\text{ V}$		3	mA
		$V_{CC} = 2.5\text{ V}$		5	
		$V_{CC} = 3.3\text{ V}$		7	
		$V_{CC} = 5.0\text{ V}$		8	
$\Delta t/\Delta v$	Input transition rise or fall rate	$V_{CC} = 1.8\text{ V}$		20	ns/V
		$V_{CC} = 3.3\text{ V or }2.5\text{ V}$		20	
		$V_{CC} = 5.0\text{ V}$		20	
T_A	Operating free-air temperature	-40	125	°C	

(1) All unused inputs of the device must be held at V_{CC} or GND to ensure proper device operation. Refer to the TI application report, *Implications of Slow or Floating CMOS Inputs*, literature number [SCBA004](#).

4.4 Electrical Characteristics

over recommended operating free-air temperature range (unless otherwise noted)

PARAMETER	TEST CONDITIONS	V_{CC}	$T_A = 25^\circ\text{C}$			$T_A = -40^\circ\text{C to }125^\circ\text{C}$		UNIT
			MIN	TYP	MAX	MIN	MAX	
V_{IH}	High-level input voltage	$V_{CC} = 1.65\text{ V to }1.8\text{ V}$	0.94			1.0		V
		$V_{CC} = 2.0\text{ V}$	1.02			1.03		
		$V_{CC} = 2.25\text{ V to }2.5\text{ V}$	1.135			1.18		
		$V_{CC} = 2.75\text{ V}$	1.21			1.23		
		$V_{CC} = 3\text{ V to }3.3\text{ V}$	1.35			1.37		
		$V_{CC} = 3.6\text{ V}$	1.47			1.48		
		$V_{CC} = 4.5\text{ V to }5.0\text{ V}$	2.02			2.03		
		$V_{CC} = 5.5\text{ V}$	2.1			2.11		
V_{IL}	Low-level input voltage	$V_{CC} = 1.65\text{ V to }2.0\text{ V}$			0.58	0.55	V	
		$V_{CC} = 2.25\text{ V to }2.75\text{ V}$			0.75	0.71		
		$V_{CC} = 3\text{ V to }3.6\text{ V}$			0.8	0.65		
		$V_{CC} = 4.5\text{ V to }5.5\text{ V}$			0.8	0.8		
V_{OH}	$I_{OH} = -20\ \mu\text{A}$	1.65 V to 5.5 V	$V_{CC} - 0.1$			$V_{CC} - 0.1$	V	
	$I_{OH} = -2.0\text{ mA}$	1.65 V	1.28		1.21		V	
		1.8V	1.5		1.45		V	
	$I_{OH} = -2.3\text{ mA}$	2.3V	2		2		V	
	$I_{OH} = -3\text{ mA}$		2		1.93		V	
	$I_{OH} = -3\text{ mA}$	2.5V	2.25		2.15		V	
	$I_{OH} = -3.0\text{ mA}$		2.78		2.7		V	
	$I_{OH} = -5.5\text{ mA}$	3.0 V	2.6		2.49		V	
	$I_{OH} = -5.5\text{ mA}$	3.3 V	2.9		2.8		V	
	$I_{OH} = -4\text{ mA}$		4.2		4.1		V	
$I_{OH} = -8\text{ mA}$	4.5 V	4.1		3.95		V		
$I_{OH} = -8\text{ mA}$	5.0 V	4.6		4.5		V		

Electrical Characteristics (continued)

over recommended operating free-air temperature range (unless otherwise noted)

PARAMETER	TEST CONDITIONS	V _{CC}	T _A = 25°C			T _A = –40°C to 125°C		UNIT	
			MIN	TYP	MAX	MIN	MAX		
V _{OL}	I _{OL} = 20 μA	1.65 V to 5.5 V			0.1		0.1		
	I _{OL} = 1.9 mA	1.65 V			0.2		0.25		
	I _{OH} = 2.3 mA	2.3V			0.1		0.15		
	I _{OH} = 3 mA				0.15		0.2		
	I _{OL} = 3 mA	3.0 V			0.1		0.15		
	I _{OL} = 5.5 mA				0.2		0.252	V	
	I _{OL} = 4 mA	4.5 V			0.15		0.2		
I _{OL} = 8 mA				0.3		0.35			
I _I	A input	V _I = 0 V or V _{CC}			0.12		±1	μA	
I _{CC}	V _I = 0 V or V _{CC} , I _O = 0; open on loading	5.0 V			1		10	μA	
		3.3 V			1		10		
		2.5 V			1		10		
		1.8V			1		10		
ΔI _{CC}	One input at 0.3V or 3.4V, Other inputs at 0 or V _{CC} , I _O = 0	5.5 V			1.35		1.5	mA	
	One input at 0.3V or 1.1V Other inputs at 0 or V _{CC} , I _O = 0	1.8V			10		10	μA	
C _i	V _I = V _{CC} or GND	3.3 V			2	10	2	10	pF
C _o	V _O = V _{CC} or GND	3.3 V			2.5		2.5		pF

4.5 Switching Characteristics

over recommended operating free-air temperature range (unless otherwise noted) (see Figure 7)

PARAMETER	FROM (INPUT)	TO (OUTPUT)	FREQUENCY (TYP)	V _{CC}	C _L	T _A = 25°C			T _A = –65°C to 125°C			UNIT	
						MIN	TYP	MAX	MIN	TYP	MAX		
t _{pd}	Any In	Y	DC to 50 MHz	5.0V	15pF			4	5		4	5	ns
					30pF			5.5	7.0		5.5	7.0	
				3.3V	15pF			4.8	5		5	5.5	ns
					30pF			5	5.5		5.5	6.5	
			DC to 25 MHz	2.5V	15pF			6	6.5		7	7.5	ns
					30pF			6.5	7.5		7.5	8.5	
			DC to 15 MHz	1.8V	15pF			10.5	11		11	12	ns
					30pF			12	13		12	14	

4.6 OPERATING CHARACTERISTICS

T_A = 25°C

PARAMETER	TEST CONDITIONS	V _{CC}	TYP	UNIT
C _{pd} Power dissipation capacitance	f = 1 MHz and 10 MHz	1.8 V ± 0.15 V	10	pF
		2.5 V ± 0.2 V	10	
		3.3 V ± 0.3 V	10	
		5.5 V ± 0.5 V	10	

5 Parameter Measurement Information

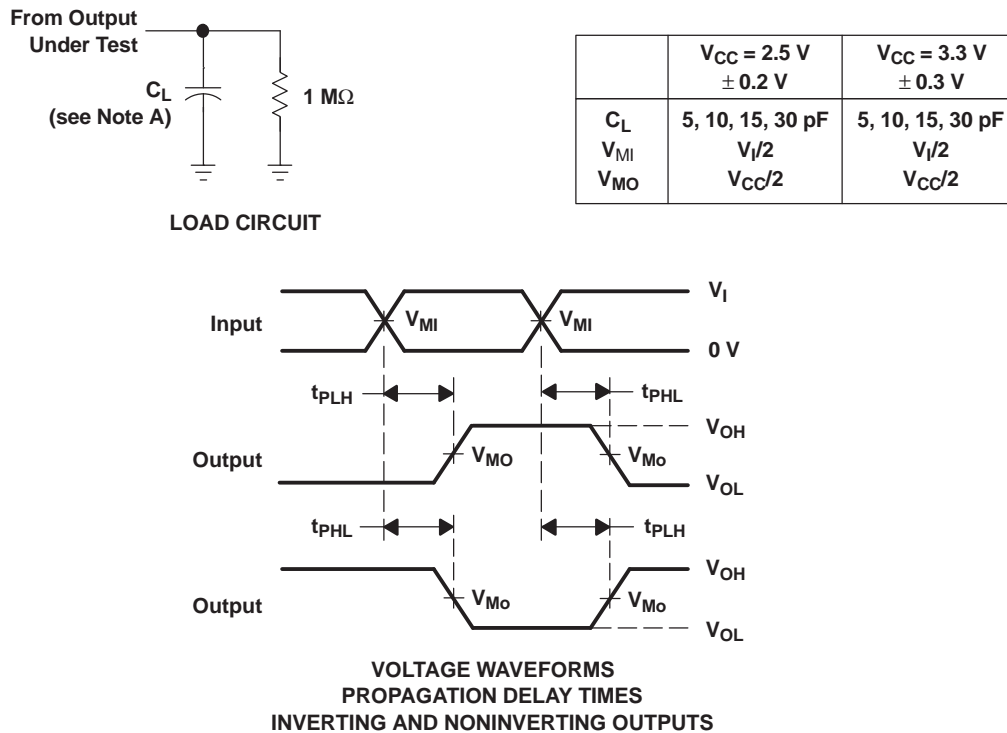

- NOTES: A. C_L includes probe and jig capacitance.
 B. All input pulses are supplied by generators having the following characteristics: PRR ≤ 10 MHz, $Z_O = 50 \Omega$, slew rate ≥ 1 V/ns.
 C. The outputs are measured one at a time, with one transition per measurement.
 D. t_{PLH} and t_{PHL} are the same as t_{pd} .

Figure 6. Load Circuit and Voltage Waveforms

5.1 More Product Selection

DEVICE	PACKAGE	DESCRIPTION
SN74LV1T00	DCK, DBV	2-Input Positive-NAND Gate
SN74LV1T02	DCK, DBV	2-Input Positive-NOR Gate
SN74LV1T04	DCK, DBV	Inverter Gate
SN74LV1T08	DCK, DBV	2-Input Positive-AND Gate
SN74LV1T17	DCK, DBV	Single Buffer Gate with 3-state Output
SN74LV1T14	DCK, DBV	Single Schmitt-Trigger Inverter Gate
SN74LV1T32	DCK, DBV	2-Input Positive-OR Gate
SN74LV1T50	DCK, DBV	Single Buffer Gate with 3-state Output
SN74LV1T86	DCK, DBV	Single 2-Input Exclusive-Or Gate
SN74LV1T125	DCK, DBV	Single Buffer Gate with 3-state Output
SN74LV1T126	DCK, DBV	Single Buffer Gate with 3-state Output
SN74LV4T125	RGY, PW	Quadruple Bus Buffer Gate With 3-State Outputs

6 器件和文档支持

6.1 Trademarks

All trademarks are the property of their respective owners.

6.2 Electrostatic Discharge Caution



These devices have limited built-in ESD protection. The leads should be shorted together or the device placed in conductive foam during storage or handling to prevent electrostatic damage to the MOS gates.

6.3 Glossary

[SLYZ022](#) — *TI Glossary*.

This glossary lists and explains terms, acronyms and definitions.

7 机械封装和可订购信息

下列封装信息和附录反映了针对指定器件可提供的最新数据。这些数据会在无通知且不对本文档进行修订的情况下发生改变。

PACKAGING INFORMATION

Orderable Device	Status (1)	Package Type	Package Drawing	Pins	Package Qty	Eco Plan (2)	Lead finish/ Ball material (6)	MSL Peak Temp (3)	Op Temp (°C)	Device Marking (4/5)	Samples
SN74LV1T00DBVR	ACTIVE	SOT-23	DBV	5	3000	RoHS & Green	NIPDAU SN	Level-1-260C-UNLIM	-40 to 125	(NEA3, NEAJ, NEAS)	Samples
SN74LV1T00DBVRG4	ACTIVE	SOT-23	DBV	5	3000	RoHS & Green	NIPDAU	Level-1-260C-UNLIM	-40 to 125	NEA3	Samples
SN74LV1T00DCKR	ACTIVE	SC70	DCK	5	3000	RoHS & Green	NIPDAU SN	Level-1-260C-UNLIM	-40 to 125	(WA3, WAJ, WAS)	Samples
SN74LV1T00DCKRG4	ACTIVE	SC70	DCK	5	3000	RoHS & Green	NIPDAU	Level-1-260C-UNLIM		WA3	Samples

(1) The marketing status values are defined as follows:

ACTIVE: Product device recommended for new designs.

LIFEBUY: TI has announced that the device will be discontinued, and a lifetime-buy period is in effect.

NRND: Not recommended for new designs. Device is in production to support existing customers, but TI does not recommend using this part in a new design.

PREVIEW: Device has been announced but is not in production. Samples may or may not be available.

OBSELETE: TI has discontinued the production of the device.

(2) **RoHS:** TI defines "RoHS" to mean semiconductor products that are compliant with the current EU RoHS requirements for all 10 RoHS substances, including the requirement that RoHS substance do not exceed 0.1% by weight in homogeneous materials. Where designed to be soldered at high temperatures, "RoHS" products are suitable for use in specified lead-free processes. TI may reference these types of products as "Pb-Free".

RoHS Exempt: TI defines "RoHS Exempt" to mean products that contain lead but are compliant with EU RoHS pursuant to a specific EU RoHS exemption.

Green: TI defines "Green" to mean the content of Chlorine (Cl) and Bromine (Br) based flame retardants meet JS709B low halogen requirements of <=1000ppm threshold. Antimony trioxide based flame retardants must also meet the <=1000ppm threshold requirement.

(3) MSL, Peak Temp. - The Moisture Sensitivity Level rating according to the JEDEC industry standard classifications, and peak solder temperature.

(4) There may be additional marking, which relates to the logo, the lot trace code information, or the environmental category on the device.

(5) Multiple Device Markings will be inside parentheses. Only one Device Marking contained in parentheses and separated by a "~" will appear on a device. If a line is indented then it is a continuation of the previous line and the two combined represent the entire Device Marking for that device.

(6) Lead finish/Ball material - Orderable Devices may have multiple material finish options. Finish options are separated by a vertical ruled line. Lead finish/Ball material values may wrap to two lines if the finish value exceeds the maximum column width.

Important Information and Disclaimer:The information provided on this page represents TI's knowledge and belief as of the date that it is provided. TI bases its knowledge and belief on information provided by third parties, and makes no representation or warranty as to the accuracy of such information. Efforts are underway to better integrate information from third parties. TI has taken and

continues to take reasonable steps to provide representative and accurate information but may not have conducted destructive testing or chemical analysis on incoming materials and chemicals. TI and TI suppliers consider certain information to be proprietary, and thus CAS numbers and other limited information may not be available for release.

In no event shall TI's liability arising out of such information exceed the total purchase price of the TI part(s) at issue in this document sold by TI to Customer on an annual basis.

TAPE AND REEL INFORMATION



QUADRANT ASSIGNMENTS FOR PIN 1 ORIENTATION IN TAPE



*All dimensions are nominal

Device	Package Type	Package Drawing	Pins	SPQ	Reel Diameter (mm)	Reel Width W1 (mm)	A0 (mm)	B0 (mm)	K0 (mm)	P1 (mm)	W (mm)	Pin1 Quadrant
SN74LV1T00DBVR	SOT-23	DBV	5	3000	178.0	9.2	3.3	3.23	1.55	4.0	8.0	Q3
SN74LV1T00DBVR	SOT-23	DBV	5	3000	178.0	9.0	3.3	3.2	1.4	4.0	8.0	Q3
SN74LV1T00DBVR	SOT-23	DBV	5	3000	180.0	8.4	3.23	3.17	1.37	4.0	8.0	Q3
SN74LV1T00DBVRG4	SOT-23	DBV	5	3000	178.0	9.2	3.3	3.23	1.55	4.0	8.0	Q3
SN74LV1T00DCKR	SC70	DCK	5	3000	178.0	9.2	2.4	2.4	1.22	4.0	8.0	Q3
SN74LV1T00DCKR	SC70	DCK	5	3000	180.0	8.4	2.47	2.3	1.25	4.0	8.0	Q3
SN74LV1T00DCKR	SC70	DCK	5	3000	178.0	9.0	2.4	2.5	1.2	4.0	8.0	Q3
SN74LV1T00DCKRG4	SC70	DCK	5	3000	178.0	9.2	2.4	2.4	1.22	4.0	8.0	Q3

TAPE AND REEL BOX DIMENSIONS

*All dimensions are nominal

Device	Package Type	Package Drawing	Pins	SPQ	Length (mm)	Width (mm)	Height (mm)
SN74LV1T00DBVR	SOT-23	DBV	5	3000	180.0	180.0	18.0
SN74LV1T00DBVR	SOT-23	DBV	5	3000	180.0	180.0	18.0
SN74LV1T00DBVR	SOT-23	DBV	5	3000	202.0	201.0	28.0
SN74LV1T00DBVRG4	SOT-23	DBV	5	3000	180.0	180.0	18.0
SN74LV1T00DCKR	SC70	DCK	5	3000	180.0	180.0	18.0
SN74LV1T00DCKR	SC70	DCK	5	3000	202.0	201.0	28.0
SN74LV1T00DCKR	SC70	DCK	5	3000	180.0	180.0	18.0
SN74LV1T00DCKRG4	SC70	DCK	5	3000	180.0	180.0	18.0

EXAMPLE BOARD LAYOUT

DBV0005A

SOT-23 - 1.45 mm max height

SMALL OUTLINE TRANSISTOR

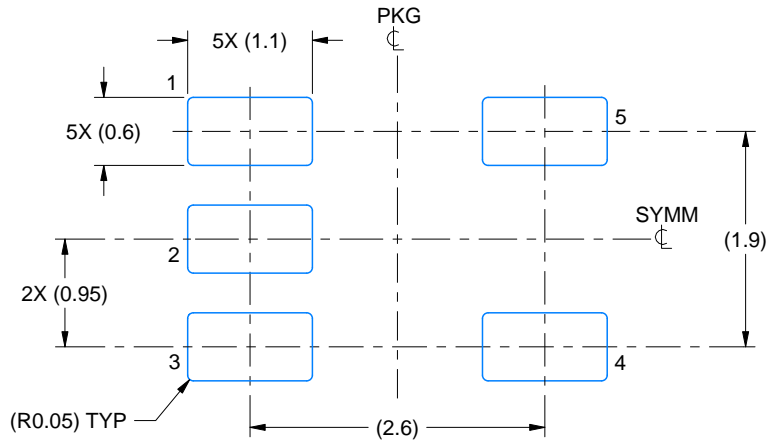

LAND PATTERN EXAMPLE
EXPOSED METAL SHOWN
SCALE:15X

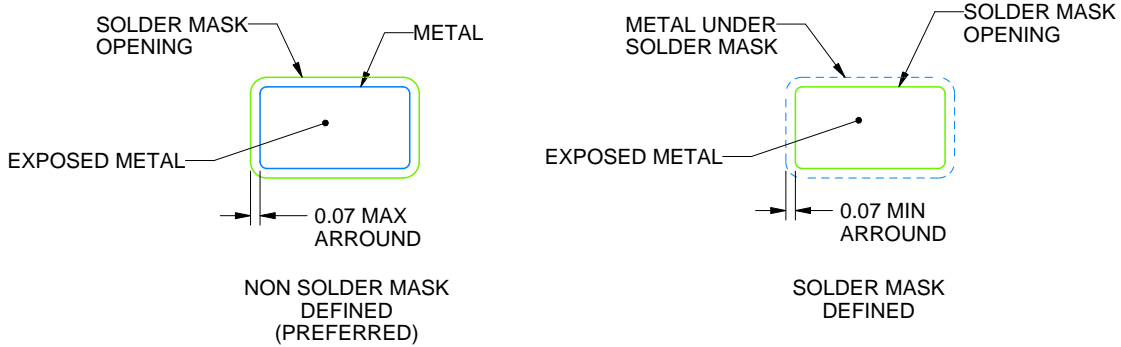

SOLDER MASK DETAILS

4214839/F 06/2021

NOTES: (continued)

- 5. Publication IPC-7351 may have alternate designs.
- 6. Solder mask tolerances between and around signal pads can vary based on board fabrication site.

EXAMPLE STENCIL DESIGN

DBV0005A

SOT-23 - 1.45 mm max height

SMALL OUTLINE TRANSISTOR

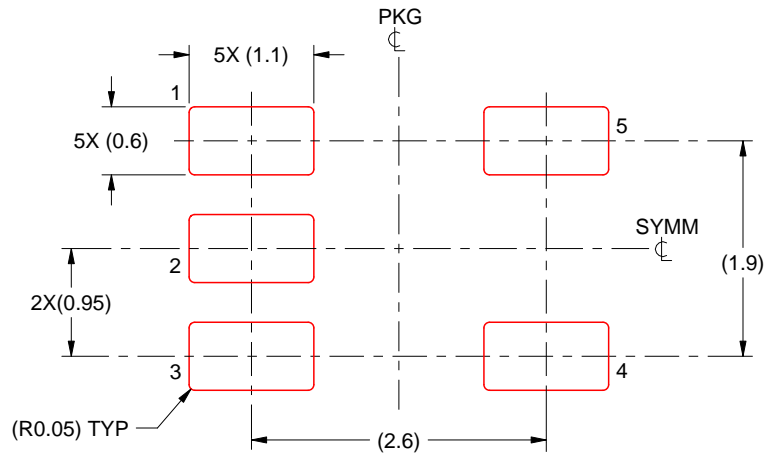

SOLDER PASTE EXAMPLE
BASED ON 0.125 mm THICK STENCIL
SCALE:15X

4214839/F 06/2021

NOTES: (continued)

7. Laser cutting apertures with trapezoidal walls and rounded corners may offer better paste release. IPC-7525 may have alternate design recommendations.
8. Board assembly site may have different recommendations for stencil design.

DCK (R-PDSO-G5)

PLASTIC SMALL-OUTLINE PACKAGE

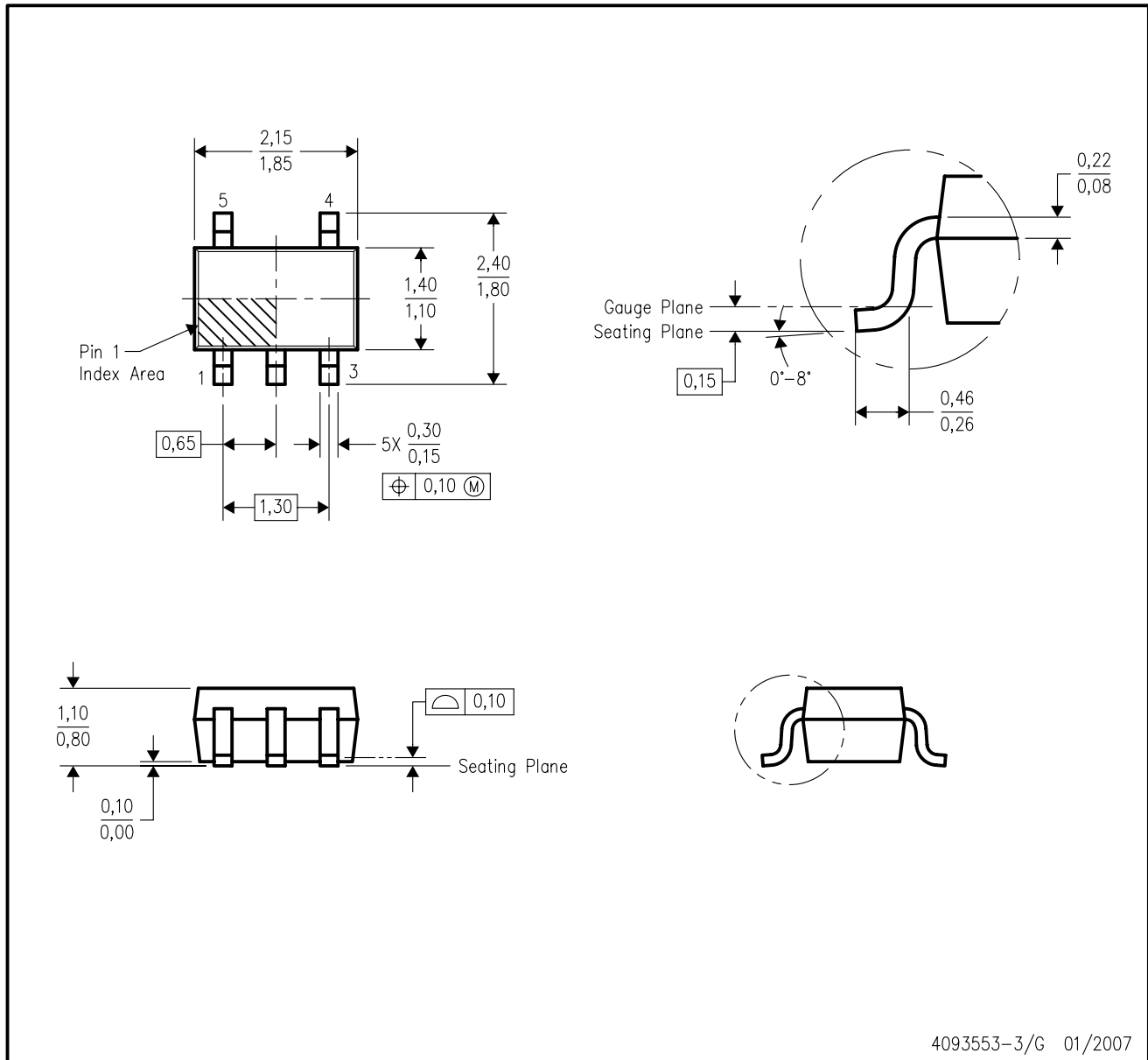

- NOTES:
- A. All linear dimensions are in millimeters.
 - B. This drawing is subject to change without notice.
 - C. Body dimensions do not include mold flash or protrusion. Mold flash and protrusion shall not exceed 0.15 per side.
 - D. Falls within JEDEC MO-203 variation AA.

DCK (R-PDSO-G5)

PLASTIC SMALL OUTLINE

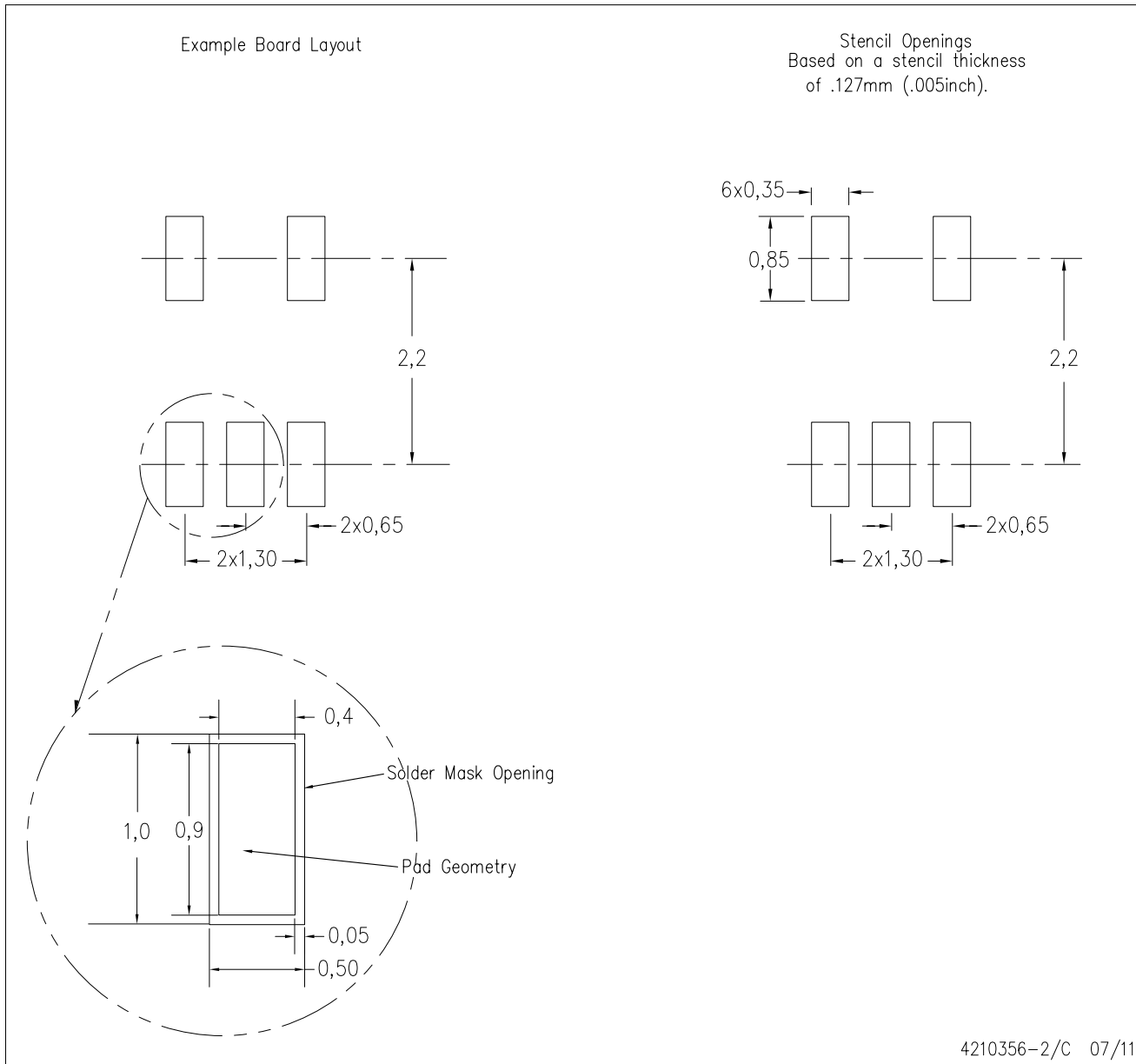

- NOTES:
- A. All linear dimensions are in millimeters.
 - B. This drawing is subject to change without notice.
 - C. Customers should place a note on the circuit board fabrication drawing not to alter the center solder mask defined pad.
 - D. Publication IPC-7351 is recommended for alternate designs.
 - E. Laser cutting apertures with trapezoidal walls and also rounding corners will offer better paste release. Customers should contact their board assembly site for stencil design recommendations. Example stencil design based on a 50% volumetric metal load solder paste. Refer to IPC-7525 for other stencil recommendations.

重要声明和免责声明

TI“按原样”提供技术和可靠性数据（包括数据表）、设计资源（包括参考设计）、应用或其他设计建议、网络工具、安全信息和其他资源，不保证没有瑕疵且不做任何明示或暗示的担保，包括但不限于对适销性、某特定用途方面的适用性或不侵犯任何第三方知识产权的暗示担保。

这些资源可供使用 TI 产品进行设计的熟练开发人员使用。您将自行承担以下全部责任：(1) 针对您的应用选择合适的 TI 产品，(2) 设计、验证并测试您的应用，(3) 确保您的应用满足相应标准以及任何其他功能安全、信息安全、监管或其他要求。

这些资源如有变更，恕不另行通知。TI 授权您仅可将这些资源用于研发本资源所述的 TI 产品的应用。严禁对这些资源进行其他复制或展示。您无权使用任何其他 TI 知识产权或任何第三方知识产权。您应全额赔偿因在这些资源的使用中对 TI 及其代表造成的任何索赔、损害、成本、损失和债务，TI 对此概不负责。

TI 提供的产品受 [TI 的销售条款](#) 或 [ti.com](#) 上其他适用条款/TI 产品随附的其他适用条款的约束。TI 提供这些资源并不会扩展或以其他方式更改 TI 针对 TI 产品发布的适用的担保或担保免责声明。

TI 反对并拒绝您可能提出的任何其他或不同的条款。

邮寄地址：Texas Instruments, Post Office Box 655303, Dallas, Texas 75265

Copyright © 2021，德州仪器 (TI) 公司