

## Micropower Voltage Mode PWM

### FEATURES

- Low 85 $\mu$ A Startup Current
- Low 300 $\mu$ A Operating Current
- Automatically Disabled Startup Preregulator
- Programmable Minimum Duty Cycle with Cycle Skipping
- Programmable Maximum Duty Cycle
- Output Current 1A Peak Source and Sink
- Programmable Soft Start
- Programmable Oscillator Frequency
- External Oscillator Synchronization Capability

### BLOCK DIAGRAM

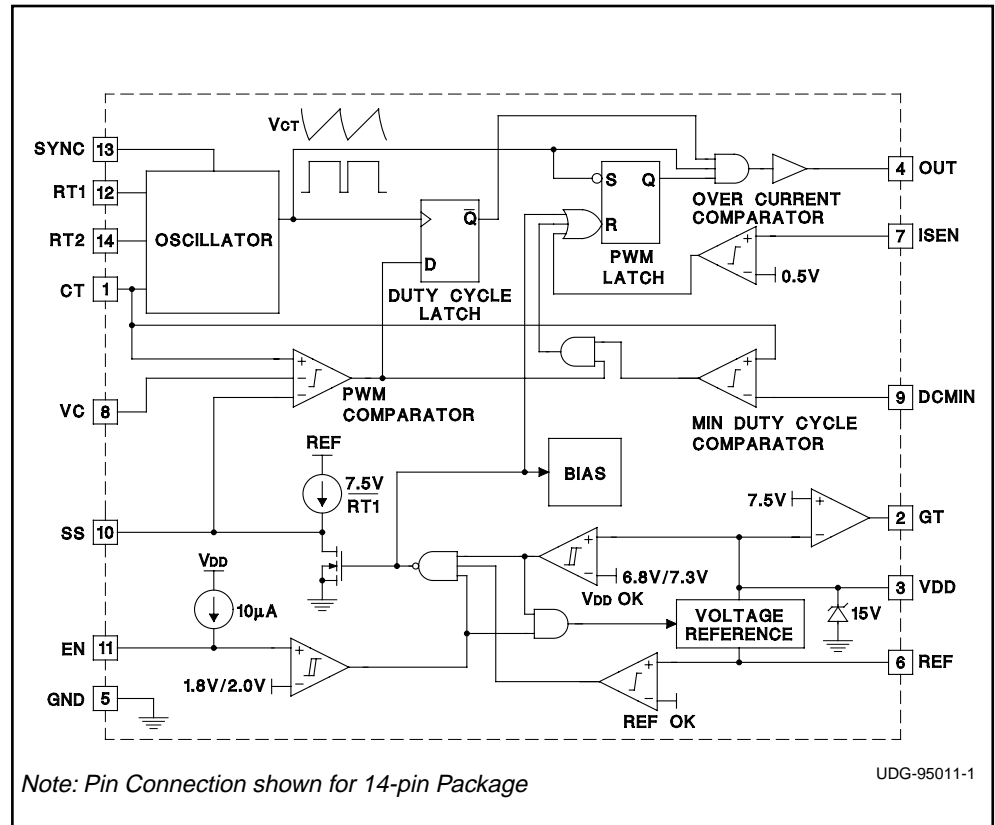

### DESCRIPTION

The UCC3581 voltage mode pulse width modulator is designed to control low power isolated DC - DC converters in applications such as Subscriber Line Power (ISDN I.430). Primarily used for single switch forward and flyback converters, the UCC3581 features BiCMOS circuitry for low startup and operating current, while maintaining the ability to drive power MOSFETs at frequencies up to 100kHz. The UCC3581 oscillator allows the flexibility to program both the frequency and the maximum duty cycle with two resistors and a capacitor. A TTL level input is also provided to allow synchronization to an external frequency source.

The UCC3581 includes programmable soft start circuitry, overcurrent detection, a 7.5V linear preregulator to control chip VDD during startup, and an on-board 4.0V logic supply.

The UCC3581 provides functions to maximize light load efficiency that are not normally found in PWM controllers.

A linear preregulator driver in conjunction with an external depletion mode N-MOSFET provides initial controller power. Once the bootstrap supply is functional, the preregulator is shut down to conserve power. During light load, power is saved by providing a programmable minimum duty cycle clamp. When a duty cycle below the minimum is called for, the modulator skips cycles to provide the correct average duty cycle required for output regulation. This effectively reduces the switching frequency, saving significant gate drive and power stage losses.

The UCC3581 is available in 14-pin plastic and ceramic dual-in-line packages and in a 14-pin narrow body small outline IC package (SOIC). The UCC1581 is specified for operation from  $-55^{\circ}\text{C}$  to  $+125^{\circ}\text{C}$ , the UCC2581 is specified for operation from  $-40^{\circ}\text{C}$  to  $+85^{\circ}\text{C}$ , and the UCC3581 is specified for operation from  $0^{\circ}\text{C}$  to  $+70^{\circ}\text{C}$ .

## ABSOLUTE MAXIMUM RATINGS

Supply Voltage ( $I_{DD} \leq 10\text{mA}$ )	15V
Supply Current	30mA
$V_{REF}$ Current	-10mA
OUT Current	$\pm 1\text{A}$
Analog Inputs	
EN	-0.3V to ( $V_{DD} + 0.3\text{V}$ )
VC, ISEN, SYNC, DCMIN	-0.3V to ( $V_{REF} + 0.3\text{V}$ )
Power Dissipation at $T_D = 25^\circ\text{C}$	
(N, J, Q, L Package)	1W
(D Package)	0.65W
Storage Temperature	$-65^\circ\text{C}$ to $+150^\circ\text{C}$
Junction Temperature	$-55^\circ\text{C}$ to $+150^\circ\text{C}$
Lead Temperature (Soldering, 10 sec.)	$+300^\circ\text{C}$

Unless otherwise specified, all voltages are with respect to Ground. Currents positive into, negative out of the specified terminal. Consult Packaging Section of Databook for thermal limitations and considerations of packages.

## CONNECTION DIAGRAMS

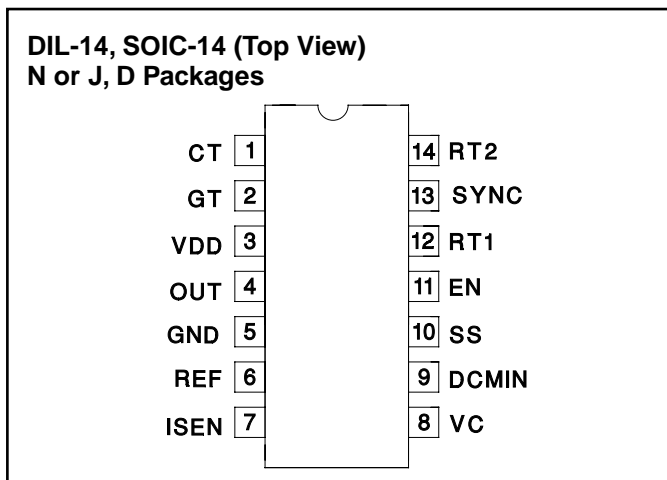

## ORDERING INFORMATION

	TEMPERATURE RANGE	PACKAGE
UCC1581J	$-55^\circ\text{C}$ to $+125^\circ\text{C}$	CDIP
UCC2581D	$-40^\circ\text{C}$ to $+85^\circ\text{C}$	SOIC
UCC2581N	$-40^\circ\text{C}$ to $+85^\circ\text{C}$	PDIP
UCC3581D	$0^\circ\text{C}$ to $+70^\circ\text{C}$	SOIC
UCC3581N	$0^\circ\text{C}$ to $+70^\circ\text{C}$	PDIP

**ELECTRICAL CHARACTERISTICS:** Unless otherwise stated, these specifications apply for  $V_{DD} = 10\text{V}$ ,  $0.1\mu\text{F}$  capacitor from  $V_{DD}$  to  $GND$ ,  $1.0\mu\text{F}$  capacitor from  $REF$  to  $GND$ ,  $RT1 = 680\text{k}\Omega$ ,  $RT2 = 12\text{k}\Omega$ ,  $CT = 750\text{pF}$  and  $T_A = T_J$ .

PARAMETER	TEST CONDITIONS	MIN	TYP	MAX	UNITS
<b>Reference Section</b>					
Output Voltage	$I = -0.2\text{mA}$	3.94	4.0	4.06	V
Load Regulation	$-5.0\text{mA} < I < -0.2\text{mA}$		20	45	mV
<b>Undervoltage Lockout Section</b>					
Start Threshold		6.7	7.3	7.9	V
Minimum Operating Voltage After Start		6.2	6.8	7.4	V
Hysteresis		0.2	0.5	0.8	V
<b>Linear Preregulator Section</b>					
Regulated $V_{DD}$ Voltage		7.0	7.5	8.0	V
Regulated $V_{DD}$ to UVLO Delta		100	230	600	mV
$V_{DD}$ Override Threshold				8.2	V
<b>Oscillator Section</b>					
Frequency	$25^\circ\text{C}$	18	19.5	21	kHz
Temperature Stability	(Note 1)		3.0		%
CT Peak Voltage	(Note 1)		2.5		V
CT Valley Voltage	(Note 1)		1.0		V
SYNC VIH		1.9	2.1	2.3	V
SYNC VIL	(Note 1)		1.8		V
<b>PWM SECTION</b>					
Maximum Duty Cycle		81	84	87	%
Minimum Duty Cycle	$(VC < 1.0\text{V})$ $DCMIN = 0\text{V}$			0	%
	$(VC > 1.0\text{V}$ at start of cycle) $DCMIN = 1.18\text{V}$	7	10	13	%
Input Bias Current	$(DCMIN)$ , (Note 1)	-150	20	150	nA
	$(VC)$ , (Note 1)	-150	20	150	nA

**ELECTRICAL CHARACTERISTICS:** Unless otherwise stated, these specifications apply for VDD = 10V, 0.1µF capacitor from VDD to GND, 1.0µF capacitor from REF to GND, RT1 = 680kΩ, RT2 = 12kΩ, CT = 750pF and TA = TJ.

PARAMETER	TEST CONDITIONS	MIN	TYP	MAX	UNITS
<b>Current Sense Section</b>					
Input Bias Current		-150	20	150	nA
Overcurrent Threshold		0.4	0.5	0.6	V
<b>Output Section</b>					
OUT Low Level	I = 100mA		0.6	1.2	V
OUT High Level	I = -100mA, VDD – OUT		0.6	1.2	V
Rise/Fall Time	(Note 1)		20	100	ns
<b>Soft start Section</b>					
Soft start Current	SS = 2V	-9	-11.5	-14	µA
<b>Chip Enable Section</b>					
VIH		1.9	2.0	2.1	V
VIL		1.7	1.8	1.9	V
Hysteresis		180	230	280	mV
Source Current		5	10	15	µA
<b>Overall Section</b>					
Start-Up Current	VDD < Start Threshold		85	130	µA
Operating Supply Current	VC = 0V		300	600	µA
VDD Zener Shunt Voltage	IDD = 10mA	13.5	15	16.5	V
IDD Stand-by Shunt Voltage	EN = 0V		100	150	µA

Note 1: Guaranteed by design. Not 100% tested in production

## PIN DESCRIPTIONS

**CT:** Oscillator timing capacitor pin. Minimum value is 100pF.

**DCMIN:** Input for programming minimum duty cycle where pulse skipping begins. This pin can be grounded to disable minimum duty cycle feature and pulse skipping.

**EN:** Enable input. This pin has an internal 10µA pull-up. A logic low input inhibits the PWM output and causes the soft start capacitor to be discharged.

**GND:** Circuit ground.

**GT:** Pin for controlling the gate of an external depletion mode N-MOSFET for the startup supply. The external N-MOSFET regulates VDD to 7.5V until the bootstrap supply comes up, then GT goes low.

**ISEN:** Input for overcurrent comparator. This function can be used for pulse-by-pulse current limiting. The threshold is 0.5V nominal.

**OUT:** Gate drive output to external N-MOSFET.

**REF:** 4.0V reference output. A minimum value bypass capacitor of 1.0µF is required for stability.

**RT1:** Resistor pin to program oscillator charging current.

The oscillator charging current is  $9.2 \cdot \left( \frac{2.0V}{RT1} \right)$ .

See Application Diagram Fig. 1.

The current into this pin is  $\left( \frac{2.0V}{RT1} \right)$ .

The value of RT1 should be between 220k and 1MΩ.

**RT2:** Resistor pin to program oscillator discharge time. The minimum value of RT2 is 10kΩ. See Application Diagram Fig. 1.

**SS:** Soft start capacitor pin. The charging current out of SS is 3.75X the current in RT1.

**SYNC:** Oscillator synchronization pin. Rising edge triggered CMOS/TTL compatible input with a 2.1V threshold. SYNC should be grounded if not used. The minimum pulse width of the SYNC signal is 100ns.

**VC:** Control voltage input to PWM comparator. The nominal control range of VC is 1.0V to 2.5V.

**VDD:** Chip input power with an 15V internal clamp. VDD is regulated by startup FET to 7.5V until the bootstrap voltage comes up. VDD should be bypassed at the chip with a 0.1µF minimum capacitor.

**APPLICATION INFORMATION**

The UCC3581's oscillator allows the user the flexibility to program the frequency and the duty cycle by adjusting two resistors and a capacitor. Application Diagram Fig. 1 shows these components as RT1, RT2, and CT. RT1 programs the timing capacitor charging current which results in a linear ramp charging CT. Discharge of CT is accomplished through RT2 which results in a standard RC discharge waveform. The oscillator on-time (CT charging) is calculated by the formula

$$t_{ON} = 0.082 \cdot RT1 \cdot CT.$$

The off-time (CT discharging) is calculated by the formula

$$t_{OFF} = 0.95 \cdot RT2 \cdot CT.$$

Resistor RT1 programs the charging current. The current is:

$$\frac{2.0V}{RT1}$$

CT charging current is 9.2 times the current in RT1. RT1 can range from 220kΩ to 1MΩ. Minimum capacitor size is 100pF, and minimum RT2 size is 10k.

A Block Diagram of the Oscillator is shown in Fig. 2. The oscillator also has an external synchronization pin. When a low to high level is detected, and if the oscillator's output is in the high state (CT charging), the oscillator output immediately goes low and CT starts discharging. The sync input is rising edge sensitive and is ignored when the oscillator output is low.

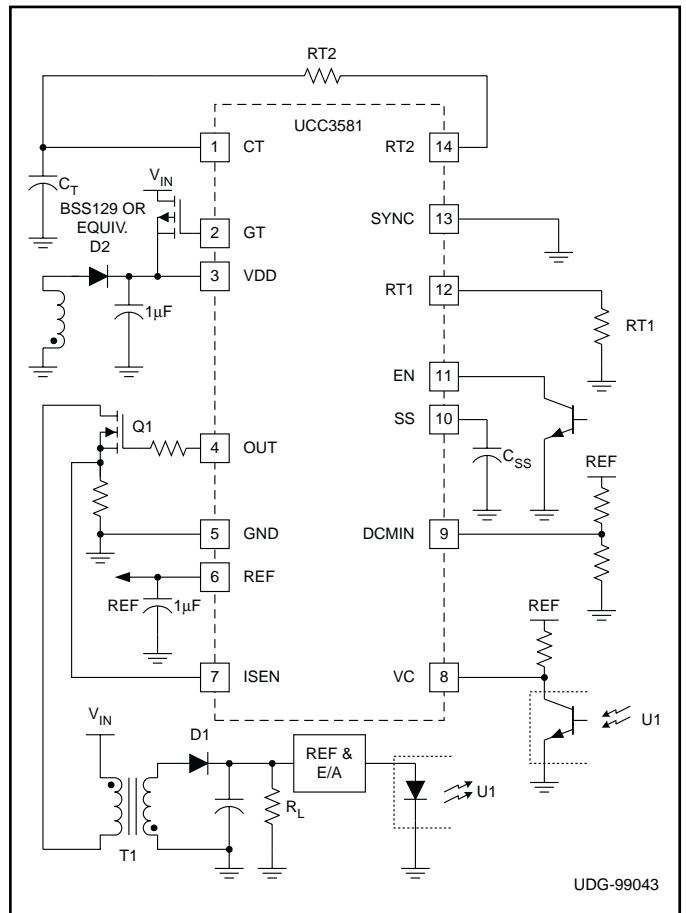

Figure 1. Application diagram.

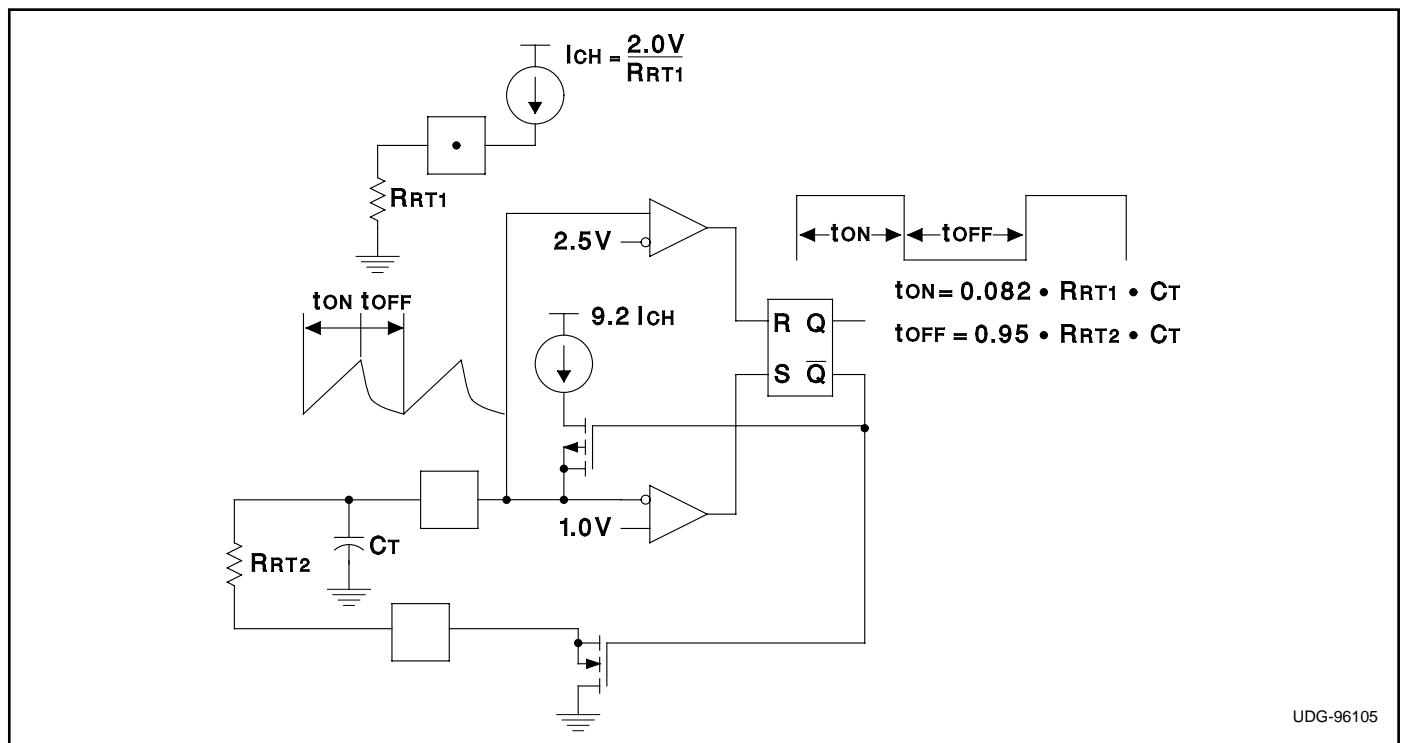

Figure 2. Oscillator.

## APPLICATION INFORMATION (cont.)

The externally bypassed 4.0V reference is controlled by undervoltage lockout and chip enable circuitry. The enable input is internally tied to a 10µA current source which allows the pin to be driven by an open collector driver. The part is also enabled if EN floats. The UCC3581 has a soft start function which requires a user supplied external timing capacitor. When in soft start mode, the soft start capacitor,  $C_{SS}$ , is charged with a constant current source. The soft start current is 3.75X the current in RT1.

There is an on-chip control amplifier, which when driving the gate of an external depletion mode N-MOSFET, acts as a 7.5V linear preregulator supplying VDD directly from the primary input power line. The preregulator may subsequently be fully disabled by a tertiary bootstrap winding providing a minimum of 8.2V to the VDD pin.

### Computation of DCMIN

DCMIN for a given duty cycle is calculated as follows:

$$\Delta V = i_{OSC} \cdot DC \cdot \frac{(t_{ON} + t_{OFF})}{C_T}$$

where:

- $i$  = oscillator charge current = 9.2 . (2.0V/RT1)
- DC = Duty Cycle, as a fraction of 1
- $t_{ON} = 0.082 \cdot RT1 \cdot CT$
- $t_{OFF} = 0.95 \cdot RT2 \cdot CT$
- $C_T$  = Oscillator Capacitor

The CT pin ramp slews from 1V to 2.5V. Therefore, add  $\Delta V$  to 1V to get DCMIN voltage.

Example: For 10% duty cycle with RT1 = 680kΩ, RT2 = 12kΩ, and CT = 705pF,

$$\Delta V = i_{OSC} \cdot DC \cdot \frac{(t_{ON} + t_{OFF})}{C_T}$$

$$= \frac{9.2 \cdot \left(\frac{2.0V}{680K}\right) \cdot (0.1) \cdot 4.182 \cdot 10^{-5} \text{ sec} + 8.55 \cdot 10^{-6} \text{ sec}}{750 \cdot 10^{-12}}$$

$$\Delta V = 0.18V$$

Therefore,

$$DCMIN = 1V + 0.18V = 1.18V$$

## A Typical Micropower Application

The circuit shown in Fig. 3 illustrates the use of the UCC3581 in a micropower application. The isolated 5V flyback power supply uses a minimum of parts and operates over an 8:1 input voltage range (15VDC to 120VDC) while delivering a regulated 5V output with a load swing from 0W to 1W. It operates in the discontinuous mode at light load or high line, and continuous mode at heavier loads and lower line voltages. Higher input line voltages are possible by simply increasing the voltage ratings of C1, Q1, D1 and D2.

The most notable feature of the design is its efficiency. With a load of 1 watt, the typical efficiency is 82%, dropping to 70% around 50mW. With a load of only 12.5mW, the efficiency remains as high as 50%. At this load, with an input of 50V, the total input current is only 500µA. Note that the power supply can be disabled by pulling the UCC3581 enable pin low, in which case the input current drops to less than 150µA.

The UCC3581 achieves very low losses by means of low quiescent current and pulse skipping at light loads which reduces switching losses. The degree of pulse skipping is controlled by programming the minimum duty cycle. In this example, the frequency is 35kHz at maximum load and drops to <2kHz at 12.5mW load (minimum pulse width of around 6µsec, or 21% duty cycle at 35kHz). Another way losses are reduced is operating with a VDD of around 10V rather than the more common 12V to 16V. At such light primary currents, the MOSFET remains in full saturation with a gate drive voltage well below 10V.

Gate drive losses are minimized by choosing a MOSFET with low total gate charge, in this case only 8nC maximum. By choosing a large gate drive resistor, EMI is minimized by reducing peak currents. Due to pulse skipping, switching times are less critical for efficiency at light load.

The shunt regulator (LM3411) and optocoupler (MOC8100) are also key to the efficiency at such light loads, and were chosen for their low operating current. The LM3411 has a quiescent current of only 150µA maximum (compared to 1mA for the more common TL431). In addition, because it is not a three terminal device, the LM3411's quiescent current does not flow in the optocoupler LED. Since this bias current is not in the feedback control path, a higher value pull-up resistor can be used on the optocoupler output transistor, further reducing losses.

TYPICAL APPLICATION

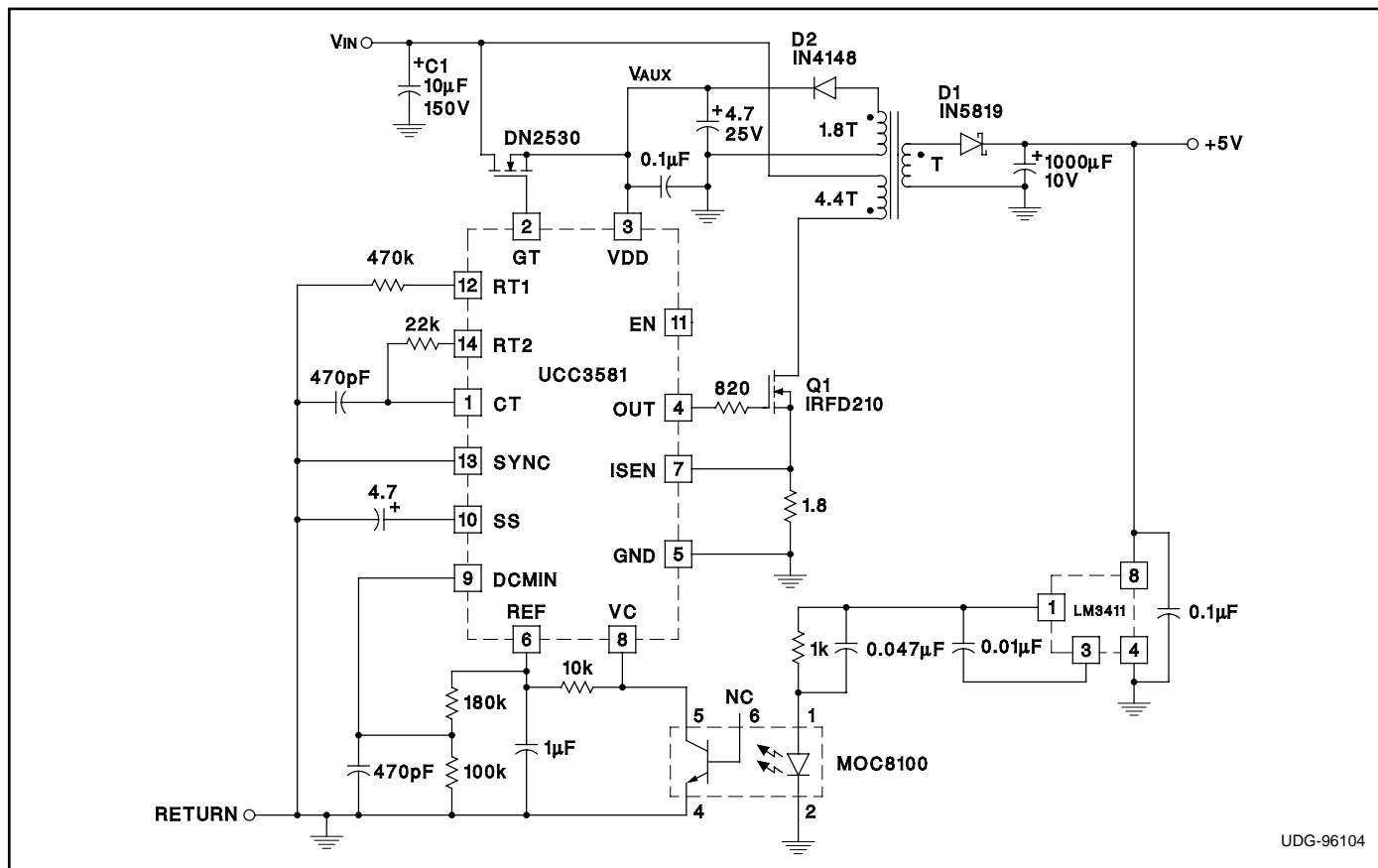

UDG-96104

Figure 3. Micropower power supply with 50% efficiency at 12.5mW load.

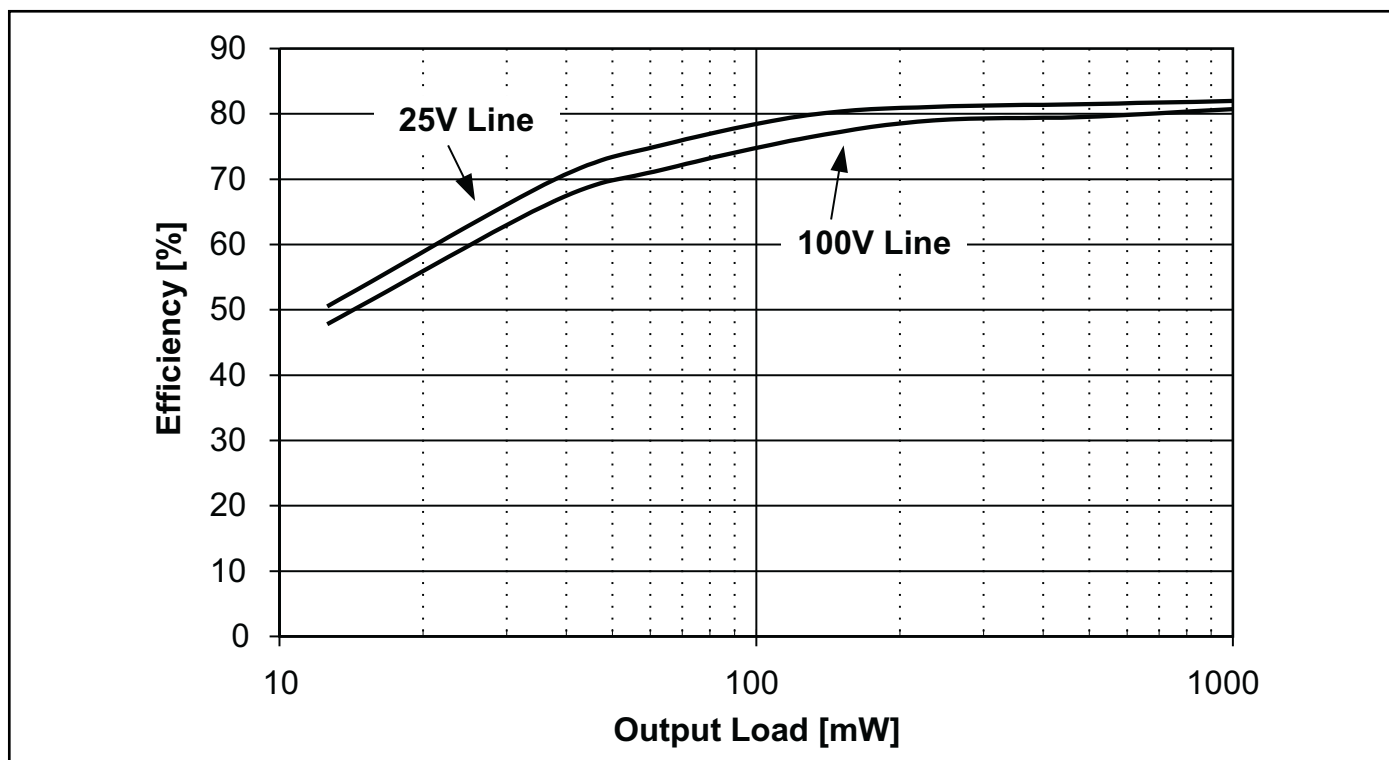

Figure 4. UCC3581 efficiency vs. line and load.

**APPLICATION INFORMATION (cont.)**

A rather large soft start capacitor was chosen to give a startup time of several hundred milliseconds, reducing the input surge current while the output is coming up.

Note that for stability, the UCC3581 VREF bypass capacitor needs to be at least 1μF. The VDD supply also needs some capacitance to hold it up between pulses at light load and high line, where the frequency may drop to less than 1kHz due to pulse skipping. Otherwise it may drop low enough for the startup MOSFET to be biased on, lowering efficiency.

If the sync input is used, it should not be left in a high impedance state where noise could cause false triggering. If unused, it should be grounded.

The transformer was designed with a standard Magnetics RM8 ferrite core using P material, gapped for an AL of 1600mH/1000Turn<sup>2</sup>. The primary consists of 44 turns, while the 5V secondary has 10 turns and the bootstrap winding 18 turns. For simplicity, all the windings can be #28 AWG. A two section bobbin was used to provide high primary to secondary isolation. A much smaller design, with reduced isolation, could have been done for this low power level.

**TYPICAL CHARACTERISTIC CURVES**

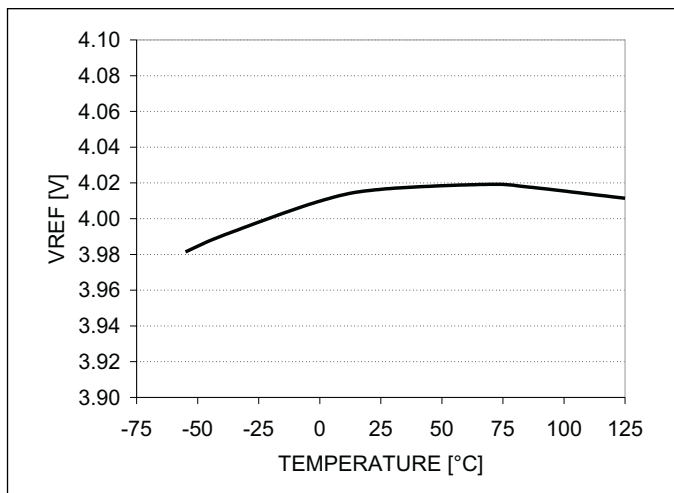

Figure 5. Reference voltage vs. temperature.

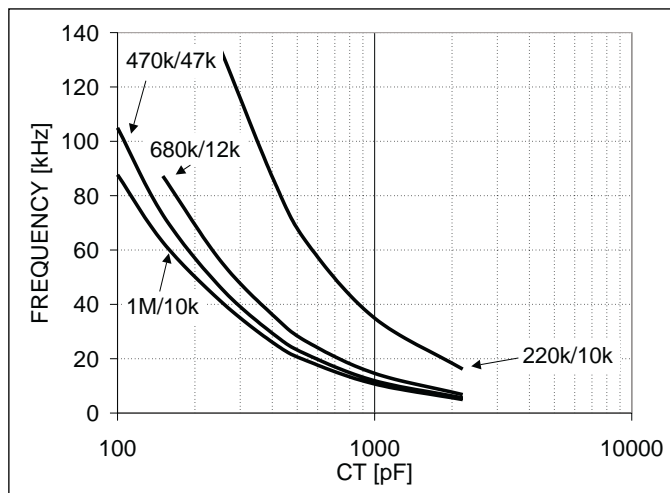

Figure 6. Frequency vs. CT vs. RT1 and RT2.

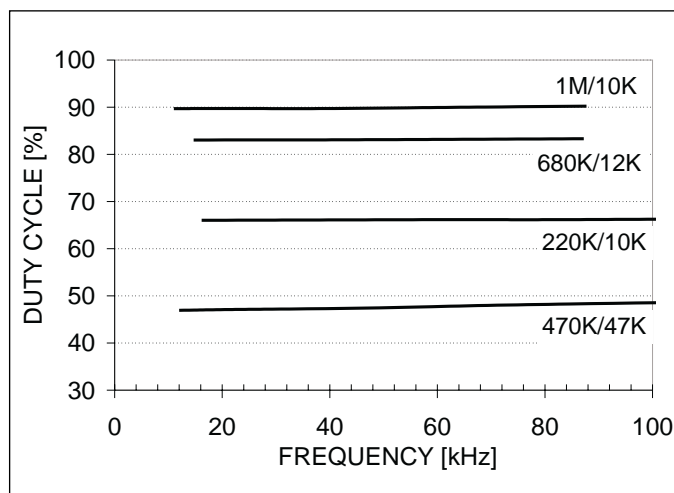

Figure 7. Duty cycle vs. frequency vs. RT1 / RT2.

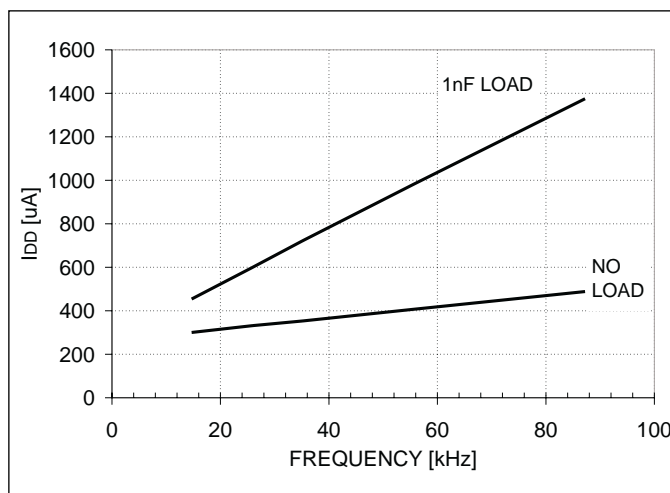
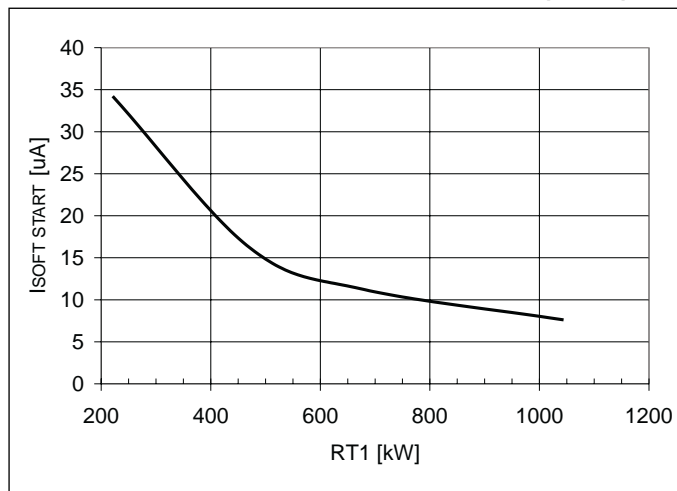

Figure 8. IDD vs. frequency RT1 = 680k, RT2 = 12k.

**TYPICAL CHARACTERISTIC CURVES (cont.)**



**Figure 9. Soft start current vs. RT1.**

**PACKAGING INFORMATION**

Orderable Device	Status (1)	Package Type	Package Drawing	Pins	Package Qty	Eco Plan (2)	Lead finish/ Ball material (6)	MSL Peak Temp (3)	Op Temp (°C)	Device Marking (4/5)	Samples
UCC2581D	ACTIVE	SOIC	D	14	50	RoHS & Green	NIPDAU	Level-2-260C-1 YEAR	-40 to 85	UCC2581D	<a href="#">Samples</a>
UCC2581DTR	ACTIVE	SOIC	D	14	2500	RoHS & Green	NIPDAU	Level-2-260C-1 YEAR	-40 to 85	UCC2581D	<a href="#">Samples</a>
UCC2581DTRG4	ACTIVE	SOIC	D	14	2500	RoHS & Green	NIPDAU	Level-2-260C-1 YEAR	-40 to 85	UCC2581D	<a href="#">Samples</a>
UCC3581D	ACTIVE	SOIC	D	14	50	RoHS & Green	NIPDAU	Level-2-260C-1 YEAR	0 to 70	UCC3581D	<a href="#">Samples</a>
UCC3581DTR	ACTIVE	SOIC	D	14	2500	RoHS & Green	NIPDAU	Level-2-260C-1 YEAR	0 to 70	UCC3581D	<a href="#">Samples</a>

(1) The marketing status values are defined as follows:

**ACTIVE:** Product device recommended for new designs.

**LIFEBUY:** TI has announced that the device will be discontinued, and a lifetime-buy period is in effect.

**NRND:** Not recommended for new designs. Device is in production to support existing customers, but TI does not recommend using this part in a new design.

**PREVIEW:** Device has been announced but is not in production. Samples may or may not be available.

**OBSELETE:** TI has discontinued the production of the device.

(2) **RoHS:** TI defines "RoHS" to mean semiconductor products that are compliant with the current EU RoHS requirements for all 10 RoHS substances, including the requirement that RoHS substance do not exceed 0.1% by weight in homogeneous materials. Where designed to be soldered at high temperatures, "RoHS" products are suitable for use in specified lead-free processes. TI may reference these types of products as "Pb-Free".

**RoHS Exempt:** TI defines "RoHS Exempt" to mean products that contain lead but are compliant with EU RoHS pursuant to a specific EU RoHS exemption.

**Green:** TI defines "Green" to mean the content of Chlorine (Cl) and Bromine (Br) based flame retardants meet JS709B low halogen requirements of <=1000ppm threshold. Antimony trioxide based flame retardants must also meet the <=1000ppm threshold requirement.

(3) MSL, Peak Temp. - The Moisture Sensitivity Level rating according to the JEDEC industry standard classifications, and peak solder temperature.

(4) There may be additional marking, which relates to the logo, the lot trace code information, or the environmental category on the device.

(5) Multiple Device Markings will be inside parentheses. Only one Device Marking contained in parentheses and separated by a "~" will appear on a device. If a line is indented then it is a continuation of the previous line and the two combined represent the entire Device Marking for that device.

(6) Lead finish/Ball material - Orderable Devices may have multiple material finish options. Finish options are separated by a vertical ruled line. Lead finish/Ball material values may wrap to two lines if the finish value exceeds the maximum column width.

**Important Information and Disclaimer:** The information provided on this page represents TI's knowledge and belief as of the date that it is provided. TI bases its knowledge and belief on information provided by third parties, and makes no representation or warranty as to the accuracy of such information. Efforts are underway to better integrate information from third parties. TI has taken and continues to take reasonable steps to provide representative and accurate information but may not have conducted destructive testing or chemical analysis on incoming materials and chemicals. TI and TI suppliers consider certain information to be proprietary, and thus CAS numbers and other limited information may not be available for release.

In no event shall TI's liability arising out of such information exceed the total purchase price of the TI part(s) at issue in this document sold by TI to Customer on an annual basis.

**TAPE AND REEL INFORMATION**

**QUADRANT ASSIGNMENTS FOR PIN 1 ORIENTATION IN TAPE**



\*All dimensions are nominal

Device	Package Type	Package Drawing	Pins	SPQ	Reel Diameter (mm)	Reel Width W1 (mm)	A0 (mm)	B0 (mm)	K0 (mm)	P1 (mm)	W (mm)	Pin1 Quadrant
UCC2581DTR	SOIC	D	14	2500	330.0	16.4	6.5	9.0	2.1	8.0	16.0	Q1
UCC3581DTR	SOIC	D	14	2500	330.0	16.4	6.5	9.0	2.1	8.0	16.0	Q1

**TAPE AND REEL BOX DIMENSIONS**

\*All dimensions are nominal

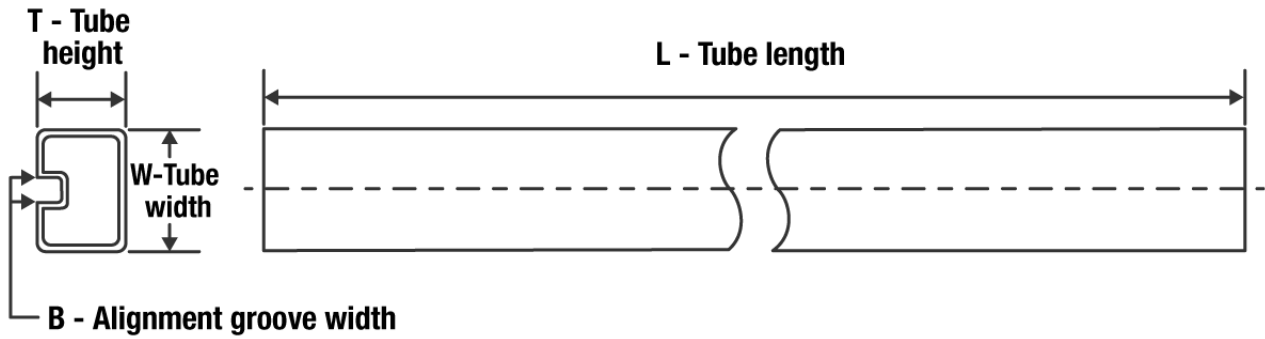
Device	Package Type	Package Drawing	Pins	SPQ	Length (mm)	Width (mm)	Height (mm)
UCC2581DTR	SOIC	D	14	2500	853.0	449.0	35.0
UCC3581DTR	SOIC	D	14	2500	853.0	449.0	35.0

**TUBE**

\*All dimensions are nominal

Device	Package Name	Package Type	Pins	SPQ	L (mm)	W (mm)	T (μm)	B (mm)
UCC2581D	D	SOIC	14	50	506.6	8	3940	4.32
UCC3581D	D	SOIC	14	50	506.6	8	3940	4.32

D (R-PDSO-G14)

PLASTIC SMALL OUTLINE



- NOTES:
- A. All linear dimensions are in inches (millimeters).
  - B. This drawing is subject to change without notice.
  - $\triangle C$  Body length does not include mold flash, protrusions, or gate burrs. Mold flash, protrusions, or gate burrs shall not exceed 0.006 (0,15) each side.
  - $\triangle D$  Body width does not include interlead flash. Interlead flash shall not exceed 0.017 (0,43) each side.
  - E. Reference JEDEC MS-012 variation AB.

D (R-PDSO-G14)

PLASTIC SMALL OUTLINE



4211283-3/E 08/12

- NOTES:
- All linear dimensions are in millimeters.
  - This drawing is subject to change without notice.
  - Publication IPC-7351 is recommended for alternate designs.
  - Laser cutting apertures with trapezoidal walls and also rounding corners will offer better paste release. Customers should contact their board assembly site for stencil design recommendations. Refer to IPC-7525 for other stencil recommendations.
  - Customers should contact their board fabrication site for solder mask tolerances between and around signal pads.

## IMPORTANT NOTICE AND DISCLAIMER

TI PROVIDES TECHNICAL AND RELIABILITY DATA (INCLUDING DATA SHEETS), DESIGN RESOURCES (INCLUDING REFERENCE DESIGNS), APPLICATION OR OTHER DESIGN ADVICE, WEB TOOLS, SAFETY INFORMATION, AND OTHER RESOURCES "AS IS" AND WITH ALL FAULTS, AND DISCLAIMS ALL WARRANTIES, EXPRESS AND IMPLIED, INCLUDING WITHOUT LIMITATION ANY IMPLIED WARRANTIES OF MERCHANTABILITY, FITNESS FOR A PARTICULAR PURPOSE OR NON-INFRINGEMENT OF THIRD PARTY INTELLECTUAL PROPERTY RIGHTS.

These resources are intended for skilled developers designing with TI products. You are solely responsible for (1) selecting the appropriate TI products for your application, (2) designing, validating and testing your application, and (3) ensuring your application meets applicable standards, and any other safety, security, regulatory or other requirements.

These resources are subject to change without notice. TI grants you permission to use these resources only for development of an application that uses the TI products described in the resource. Other reproduction and display of these resources is prohibited. No license is granted to any other TI intellectual property right or to any third party intellectual property right. TI disclaims responsibility for, and you will fully indemnify TI and its representatives against, any claims, damages, costs, losses, and liabilities arising out of your use of these resources.

TI's products are provided subject to [TI's Terms of Sale](#) or other applicable terms available either on [ti.com](http://ti.com) or provided in conjunction with such TI products. TI's provision of these resources does not expand or otherwise alter TI's applicable warranties or warranty disclaimers for TI products.

TI objects to and rejects any additional or different terms you may have proposed.

Mailing Address: Texas Instruments, Post Office Box 655303, Dallas, Texas 75265  
Copyright © 2022, Texas Instruments Incorporated