

24 位、192 kHz 采样、增强型多级 $\Delta\Sigma$ 、 立体声、音频数模转换器

查询样品: [PCM1789-Q1](#)

特性

- 符合汽车应用要求
- 增强型多级 $\Delta\Sigma$ DAC:
 - 高性能: 差动、 $f_S = 48 \text{ kHz}$
 - **THD+N: -94 dB**
 - **SNR: 113 dB**
 - 动态范围: **113 dB**
 - 采样速率: **8 kHz 至 192 kHz**
 - 系统时钟: **128 f_S 、192 f_S 、256 f_S 、384 f_S 、512 f_S 、768 f_S 、1152 f_S**
 - 差动电压输出: **8 V_{PP}**
 - 提供模拟低通放大器
 - **4x/8x** 过采样数字滤波器:
 - 通带纹波: **$\pm 0.0018 \text{ dB}$**
 - 阻带衰减: **-75 dB**
 - 零标记 (**16/20/24** 位)
- 高灵活音频接口:
 - **I/F** 格式: **I²STM**、左/右对齐、**DSP**
 - 数据长度: **16、20、24、32** 位
- 高灵活模型控制:
 - **3 线 SPITM** 与 **2 线 I²CTM** 兼容型串行控制接口、或硬件控制
 - 通过单个 **SPI** 总线连接多达 **4** 个设备
- 通过 **SPI** 或 **I²C** **I/F** 实现的多功能:
 - 音频 **I/F** 格式选择: **I²S**、左对齐、右对齐、**DSP**
 - 数字衰减与软静音
 - 数字去加重: **32 kHz、44.1 kHz、48 kHz**
 - 数据极性控制
 - 节电模式
- 通过硬件控制实现的多功能:

- 音频 **I/F** 格式选择: **I²S**、左对齐
- 数字去加重滤波器: **44.1 kHz**
- 通过时钟停止检测实现模拟静音
- 外部复位引脚
- 电源:
 - **5 V** 模拟与 **3.3 V** 数字
- 封装: **TSSOP-24**
- 工作温度范围:
 - **-40°C to +105°C**

应用 TM

- **AV** 接收器
- 汽车音频外部放大器
- 汽车音频 **AVN** 应用

说明

PCM1789-Q1 是一款支持差动输出的高性能、单芯片、24 位、立体声音频数模转换器 (DAC)。双通道 24 位 DAC 部署了增强型多级 $\Delta\Sigma$ 调制器, 支持 8 kHz 至 192 kHz 的采样速率以及通过音频接口实现的 16/20/24/32 位宽度数字音频字长。PCM1789-Q1 的音频接口除了支持 **I²S**、左对齐与右对齐格式之外, 还支持 24 位 **DSP** 格式。

PCM1789-Q1 可在软件中通过 3 线、**SPI** 兼容型或 2 线、**I²C** 兼容型串行接口进行控制, 能够实现包括数字衰减、软静音、去加重等所有功能。此外, 硬件控制模式还可通过 2 个控制引脚实现 2 个用户可编程功能。PCM1789-Q1 采用 24 引脚 **TSSOP** 封装。



Please be aware that an important notice concerning availability, standard warranty, and use in critical applications of Texas Instruments semiconductor products and disclaimers thereto appears at the end of this data sheet.

SPI is a trademark of Motorola, Inc.
I²S, **I²C** are trademarks of NXP 半导体.
is a trademark of ~其它.



This integrated circuit can be damaged by ESD. Texas Instruments recommends that all integrated circuits be handled with appropriate precautions. Failure to observe proper handling and installation procedures can cause damage.

ESD damage can range from subtle performance degradation to complete device failure. Precision integrated circuits may be more susceptible to damage because very small parametric changes could cause the device not to meet its published specifications.

ORDERING INFORMATION⁽¹⁾

T _A	PACKAGE		ORDERABLE PART	TOP-SIDE MARKING
–40°C to 105°C	TSSOP-24 – PW	Reel of 2000	PCM1789TPWRQ1	PCM1789T

(1) For the most current package and ordering information see the Package Option Addendum at the end of this document, or see the TI web site at www.ti.com.

ABSOLUTE MAXIMUM RATINGS⁽¹⁾

Over operating free-air temperature range (unless otherwise noted).

PARAMETER		PCM1789-Q1	UNIT
Supply voltage	VCC1, VCC2	–0.3 to +6.5	V
	VDD	–0.3 to +4.0	V
Ground voltage differences: AGND1, AGND2, DGND		±0.1	V
Supply voltage differences: VCC1, VCC2		±0.1	V
Digital input voltage	RST, ADR5, MS, MC, MD, SCKI, AMUTEI	–0.3 to +6.5	V
	BCK, LRCK, DIN, MODE, ZERO1, ZERO2	–0.3 to (VDD + 0.3) < +4.0	V
Analog input voltage: VCOM, VOUTL±, VOUTR±		–0.3 to (VCC + 0.3) < +6.5	V
Input current (all pins except supplies)		±10	mA
Ambient temperature under bias		–40 to +125	°C
Storage temperature		–55 to +150	°C
Junction temperature		+150	°C
Lead temperature (soldering, 5s)		+260	°C
Package temperature (IR reflow, peak)		+260	°C

(1) Stresses beyond those listed under *Absolute Maximum Ratings* may cause permanent damage to the device. These are stress ratings only and functional operation of the device at these or any other conditions beyond those indicated under *Recommended Operating Conditions* is not implied. Exposure to absolute-maximum-rated conditions for extended periods may affect device reliability.

RECOMMENDED OPERATING CONDITIONS

Over operating free-air temperature range (unless otherwise noted).

PARAMETER		PCM1789-Q1			UNIT
		MIN	TYP	MAX	
Analog supply voltage, VCC		4.5	5.0	5.5	V
Digital supply voltage, VDD		3.0	3.3	3.6	V
Digital Interface		LVTTTL-compatible			
Digital input clock frequency	Sampling frequency, LRCK	8		192	kHz
	System clock frequency, SCKI	2.048		36.864	MHz
Analog output voltage	Differential		8		V _{PP}
Analog output load resistance	To ac-coupled GND	5			kΩ
	To dc-coupled GND	15			kΩ
Analog output load capacitance				50	pF
Digital output load capacitance				20	pF
Operating free-air temperature	PCM1789-Q1 consumer grade	–40	25	105	°C

ELECTRICAL CHARACTERISTICS: Digital Input/Output

All specifications at $T_A = +25^\circ\text{C}$, $V_{CC1} = V_{CC2} = 5\text{ V}$, $V_{DD} = 3.3\text{ V}$, $f_S = 48\text{ kHz}$, $SCKI = 512 f_S$, 24-bit data, and Sampling mode = Auto, unless otherwise noted.

PARAMETER	TEST CONDITIONS	PCM1789-Q1			UNIT
		MIN	TYP	MAX	
DATA FORMAT					
Audio data interface format		I ² S, LJ, RJ, DSP			
Audio data word length		16, 20, 24, 32			Bits
Audio data format		MSB first, twos complement			
Sampling frequency	f_S	8	48	192	kHz
System clock frequency	128 f_S , 192 f_S , 256 f_S , 384 f_S , 512 f_S , 768 f_S , 1152 f_S	2.048		36.864	MHz
INPUT LOGIC					
Input logic level	$V_{IH}^{(1)(2)}$	2.0		VDD	VDC
	$V_{IL}^{(1)(2)}$			0.8	VDC
Input logic level	$V_{IH}^{(3)(4)}$	2.0		5.5	VDC
	$V_{IL}^{(3)(4)}$			0.8	VDC
Input logic current	$I_{IH}^{(2)(3)}$	$V_{IN} = V_{DD}$		± 10	μA
	$I_{IL}^{(2)(3)}$	$V_{IN} = 0\text{ V}$		± 10	μA
Input logic current	$I_{IH}^{(1)(4)}$	$V_{IN} = V_{DD}$	+65	+100	μA
	$I_{IL}^{(1)(4)}$	$V_{IN} = 0\text{ V}$		± 10	μA
OUTPUT LOGIC					
Output logic level	$V_{OH}^{(5)}$	$I_{OUT} = -4\text{ mA}$	2.4		VDC
	$V_{OL}^{(5)(6)}$	$I_{OUT} = +4\text{ mA}$		0.4	VDC
REFERENCE OUTPUT					
VCOM output voltage			$0.5 \times V_{CC1}$		V
VCOM output impedance			7.5		k Ω
Allowable VCOM output source/sink current				1	μA

- (1) BCK and LRCK (Schmitt trigger input with 50-k Ω typical internal pull-down resistor).
- (2) DIN (Schmitt trigger input).
- (3) SCKI, ADR5/ADR1/RSV, MC/SCL/FMT, MD/SDA/DEMP, and AMUTEI (Schmitt trigger input, 5-V tolerant).
- (4) RST and MS/ADR0/RSV (Schmitt trigger input with 50-k Ω typical internal pull-down resistor, 5-V tolerant).
- (5) ZERO1 and ZERO2.
- (6) AMUTEO and SDA (I²C mode, open-drain low output).

ELECTRICAL CHARACTERISTICS: DAC

All specifications at $T_A = +25^\circ\text{C}$, $V_{CC1} = V_{CC2} = 5\text{ V}$, $V_{DD} = 3.3\text{ V}$, $f_S = 48\text{ kHz}$, $\text{SCKI} = 512 f_S$, 24-bit data, and Sampling mode = Auto, unless otherwise noted.

PARAMETER	TEST CONDITIONS	PCM1789-Q1			UNIT		
		MIN	TYP	MAX			
RESOLUTION		16	24		Bits		
DC ACCURACY							
Gain mismatch channel-to-channel			± 2.0	± 6.0	% of FSR		
Gain error			± 2.0	± 6.0	% of FSR		
Bipolar zero error			± 1.0		% of FSR		
DYNAMIC PERFORMANCE^{(1) (2)}							
Total harmonic distortion + noise	THD+N	$V_{OUT} = 0\text{ dB}$	$f_S = 48\text{ kHz}$		-94	-88	dB
			$f_S = 96\text{ kHz}$		-94		dB
			$f_S = 192\text{ kHz}$		-94		dB
Dynamic range			$f_S = 48\text{ kHz}$, EIAJ, A-weighted	106	113		dB
			$f_S = 96\text{ kHz}$, EIAJ, A-weighted		113		dB
			$f_S = 192\text{ kHz}$, EIAJ, A-weighted		113		dB
Signal-to-noise ratio	SNR		$f_S = 48\text{ kHz}$, EIAJ, A-weighted	106	113		dB
			$f_S = 96\text{ kHz}$, EIAJ, A-weighted		113		dB
			$f_S = 192\text{ kHz}$, EIAJ, A-weighted		113		dB
Channel separation			$f_S = 48\text{ kHz}$	103	109		dB
			$f_S = 96\text{ kHz}$		109		dB
			$f_S = 192\text{ kHz}$		108		dB
ANALOG OUTPUT							
Output voltage	Differential		$1.6 \times V_{CC1}$		V_{PP}		
Center voltage			$0.5 \times V_{CC1}$		V		
Load impedance	To ac-coupled GND ⁽³⁾	5			k Ω		
	To dc-coupled GND ⁽³⁾	15			k Ω		
LPF frequency response			$f = 20\text{ kHz}$		-0.04	dB	
			$f = 44\text{ kHz}$		-0.18	dB	
DIGITAL FILTER PERFORMANCE WITH SHARP ROLL-OFF							
Passband (single, dual)			Except $\text{SCKI} = 128 f_S$ and $192 f_S$		$0.454 \times f_S$	Hz	
			$\text{SCKI} = 128 f_S$ and $192 f_S$		$0.432 \times f_S$	Hz	
Passband (quad)					$0.432 \times f_S$	Hz	
Stop band (single, dual)			Except $\text{SCKI} = 128 f_S$ and $192 f_S$	$0.546 \times f_S$		Hz	
			$\text{SCKI} = 128 f_S$ and $192 f_S$	$0.569 \times f_S$		Hz	
Stop band (quad)			$0.569 \times f_S$		Hz		
Passband ripple			$< 0.454 \times f_S$, $0.432 \times f_S$		± 0.0018	dB	
Stop band attenuation			$> 0.546 \times f_S$, $0.569 \times f_S$	-75		dB	

(1) In differential mode at $V_{OUTx\pm}$ pin, $f_{OUT} = 1\text{ kHz}$, using Audio Precision System II, Average mode with 20-kHz LPF and 400-Hz HPF.

(2) $f_S = 48\text{ kHz}$: $\text{SCKI} = 512 f_S$ (single), $f_S = 96\text{ kHz}$: $\text{SCKI} = 256 f_S$ (dual), $f_S = 192\text{ kHz}$: $\text{SCKI} = 128 f_S$ (quad).

(3) Allowable minimum input resistance of differential-to-single-ended converter with D-to-S gain = G is calculated as $(1 + 2G)/(1 + G) \times 5\text{ k}$ for ac-coupled, and $(1 + 0.9G)/(1 + G) \times 15\text{ k}$ for dc-coupled connection; refer to [Figure 38](#) and [Figure 39](#).

ELECTRICAL CHARACTERISTICS: DAC (continued)

All specifications at $T_A = +25^\circ\text{C}$, $V_{CC1} = V_{CC2} = 5\text{ V}$, $V_{DD} = 3.3\text{ V}$, $f_S = 48\text{ kHz}$, $SCKI = 512 f_S$, 24-bit data, and Sampling mode = Auto, unless otherwise noted.

PARAMETER	TEST CONDITIONS	PCM1789-Q1			UNIT
		MIN	TYP	MAX	
DIGITAL FILTER PERFORMANCE WITH SLOW ROLL-OFF					
Passband				$0.328 \times f_S$	Hz
Stop band		$0.673 \times f_S$			Hz
Passband ripple	$< 0.328 \times f_S$			± 0.0013	dB
Stop band attenuation	$> 0.673 \times f_S$	-75			dB
DIGITAL FILTER PERFORMANCE					
Group delay time (single, dual)	Except $SCKI = 128 f_S$ and $192 f_S$		$28/f_S$		sec
	$SCKI = 128 f_S$ and $192 f_S$		$19/f_S$		sec
Group delay time (quad)			$19/f_S$		sec
De-emphasis error			± 0.1		dB

ELECTRICAL CHARACTERISTICS: Power-Supply Requirements

All specifications at $T_A = +25^\circ\text{C}$, $V_{CC1} = V_{CC2} = 5\text{ V}$, $V_{DD} = 3.3\text{ V}$, $f_S = 48\text{ kHz}$, $SCKI = 512 f_S$, 24-bit data, and Sampling mode = Auto, unless otherwise noted.

PARAMETER	TEST CONDITIONS	PCM1789-Q1			UNIT	
		MIN	TYP	MAX		
POWER-SUPPLY REQUIREMENTS						
Voltage range	$V_{CC1/2}$	4.5	5.0	5.5	VDC	
	VDD	3.0	3.3	3.6	VDC	
Supply current	I_{CC}	$f_S = 48\text{ kHz}$	19	28	mA	
		$f_S = 192\text{ kHz}$	19		mA	
		Full power-down ⁽¹⁾	170		μA	
	I_{DD}	$f_S = 48\text{ kHz}$		18	30	mA
		$f_S = 192\text{ kHz}$		22		mA
		Full power-down ⁽¹⁾		60		μA
Power dissipation	$f_S = 48\text{ kHz}$		154	239	mW	
	$f_S = 192\text{ kHz}$		168		mW	
	Full power-down ⁽¹⁾		1.05		mW	
TEMPERATURE RANGE						
Operating temperature	PCM1789-Q1 consumer grade	-40		+85	$^\circ\text{C}$	
Thermal resistance	θ_{JA} TSSOP-24		115		$^\circ\text{C/W}$	

(1) SCKI, BCK, and LRCK stopped.

PIN CONFIGURATION

PW PACKAGE TSSOP-24 (TOP VIEW)

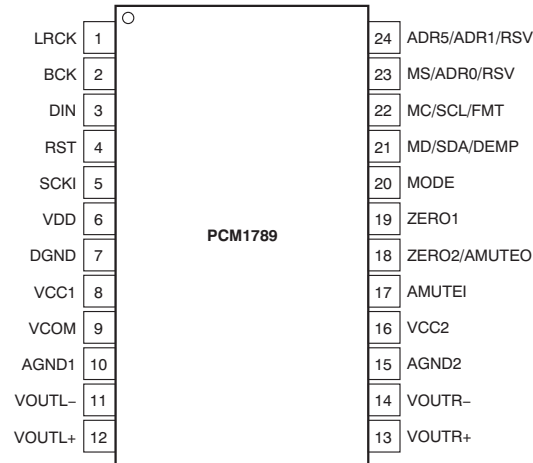

TERMINAL FUNCTIONS

TERMINAL		I/O	PULL-DOWN	5-V TOLERANT	DESCRIPTION
NAME	PIN				
LRCK	1	I	Yes	No	Audio data word clock input
BCK	2	I	Yes	No	Audio data bit clock input
DIN	3	I	No	No	Audio data input
RST	4	I	Yes	Yes	Reset and power-down control input with active low
SCKI	5	I	No	Yes	System clock input
VDD	6	—	—	—	Digital power supply, +3.3 V
DGND	7	—	—	—	Digital ground
VCC1	8	—	—	—	Analog power supply 1, +5 V
VCOM	9	—	—	—	Voltage common decoupling
AGND1	10	—	—	—	Analog ground 1
VOU TL-	11	O	No	No	Negative analog output from DAC left channel
VOU TL+	12	O	No	No	Positive analog output from DAC left channel
VOU TR+	13	O	No	No	Positive analog output from DAC right channel
VOU TR-	14	O	No	No	Negative analog output from DAC right channel
AGND2	15	—	—	—	Analog ground 2
VCC2	16	—	—	—	Analog power supply 2, +5 V
AMUTEI	17	I	No	Yes	Analog mute control input with active low
ZERO2/AMUTE0	18	O	No	No	Zero detect flag output 2/Analog mute control output ⁽¹⁾ with active low
ZERO1	19	O	No	No	Zero detect flag output 1
MODE	20	I	No	No	Control port mode selection. Tied to VDD: SPI, ADR6 = 1, pull-up: SPI, ADR6 = 0, pull-down: H/W auto mode, tied to DGND: I ² C
MD/SDA/DEMP	21	I/O	No	Yes	Input data for SPI, data for I ² C ⁽¹⁾ , de-emphasis control for hardware control mode
MC/SCL/FMT	22	I	No	Yes	Clock for SPI, clock for I ² C, format select for hardware control mode
MS/ADR0/RSV	23	I	Yes	Yes	Chip Select for SPI, address select 0 for I ² C, reserve (set low) for hardware control mode
ADR5/ADR1/RSV	24	I	No	Yes	Address select 5 for SPI, address select 1 for I ² C, reserve (set low) for hardware control mode

(1) Open-drain configuration in out mode.

FUNCTIONAL BLOCK DIAGRAM

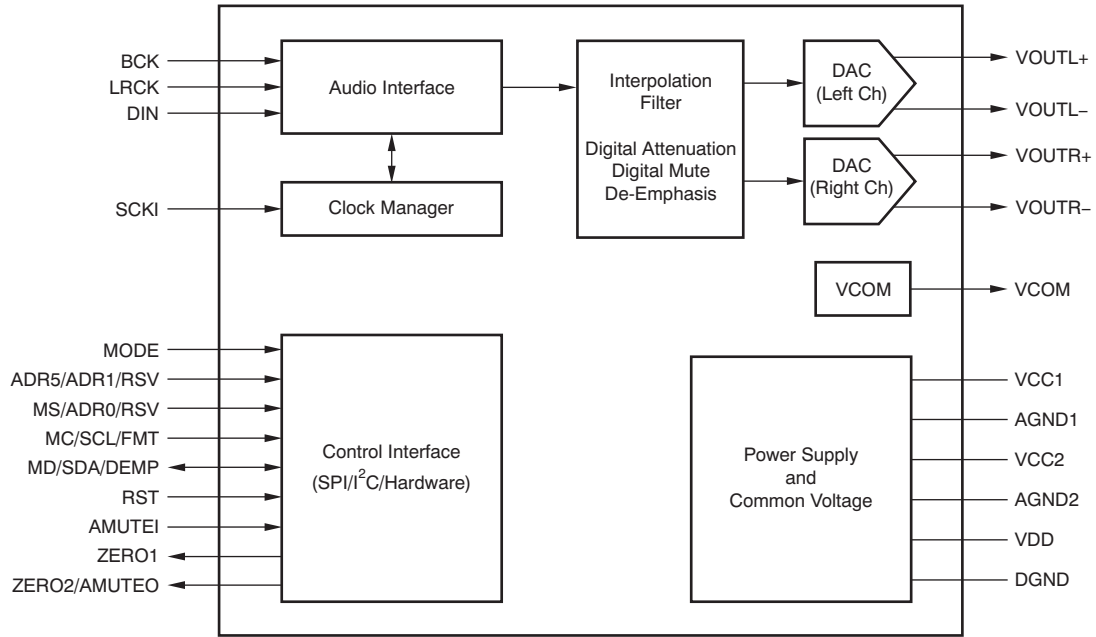

TYPICAL CHARACTERISTICS: Digital Filter

All specifications at $T_A = +25^\circ\text{C}$, $V_{CC1} = V_{CC2} = 5\text{ V}$, $V_{DD} = 3.3\text{ V}$, $f_S = 48\text{ kHz}$, $SCKI = 512 f_S$, 24-bit data, and Sampling mode = Auto, unless otherwise noted.

**FREQUENCY RESPONSE
(Single Rate)**

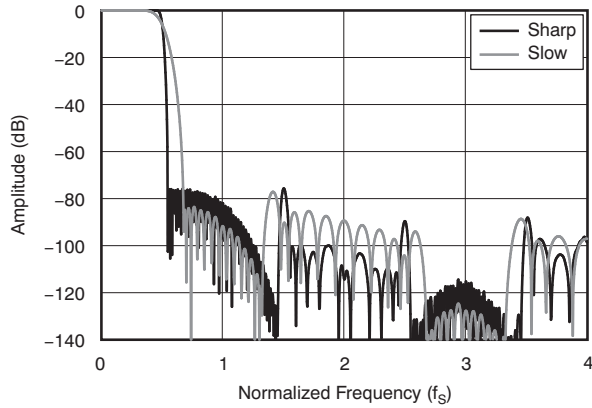

Figure 1.

**FREQUENCY RESPONSE PASSBAND
(Single Rate)**

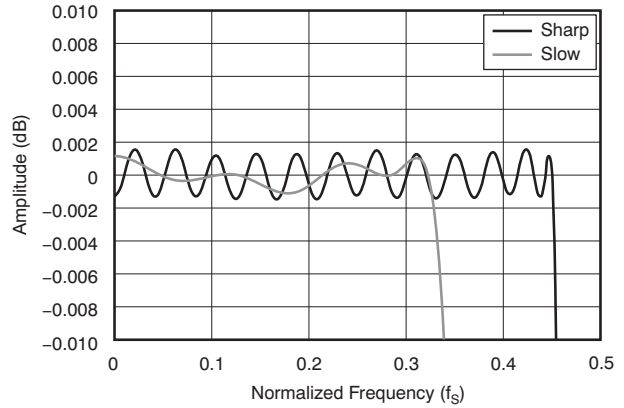

Figure 2.

**FREQUENCY RESPONSE
(Dual Rate)**

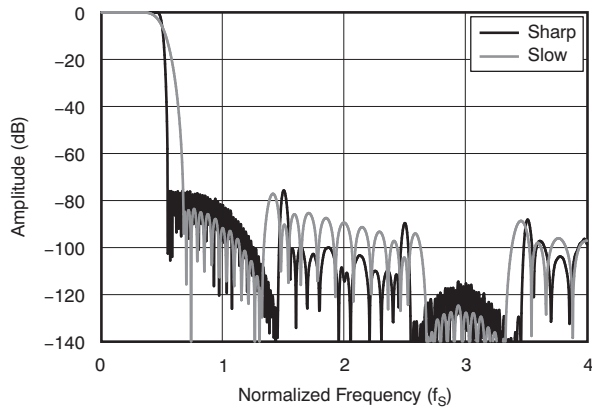

Figure 3.

**FREQUENCY RESPONSE PASSBAND
(Dual Rate)**

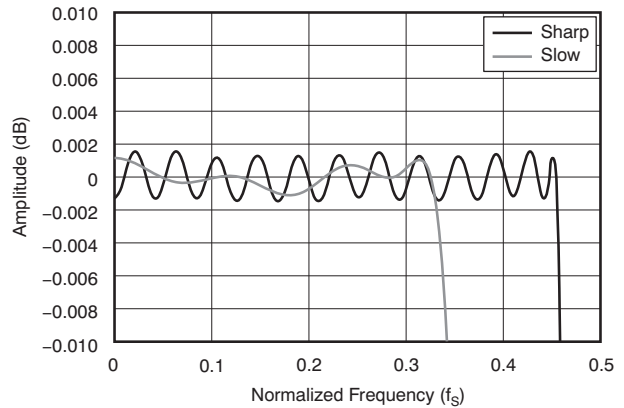

Figure 4.

**FREQUENCY RESPONSE
(Quad Rate)**

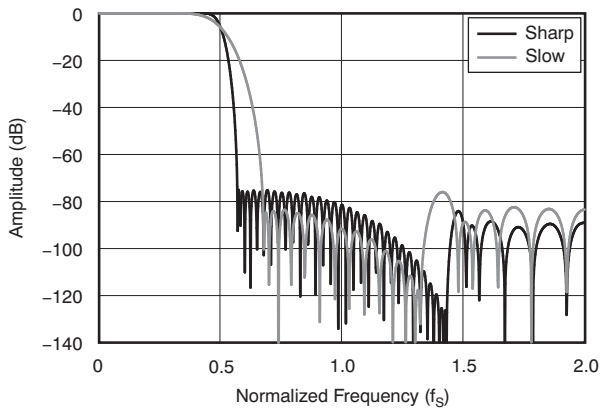

Figure 5.

**FREQUENCY RESPONSE PASSBAND
(Quad Rate)**

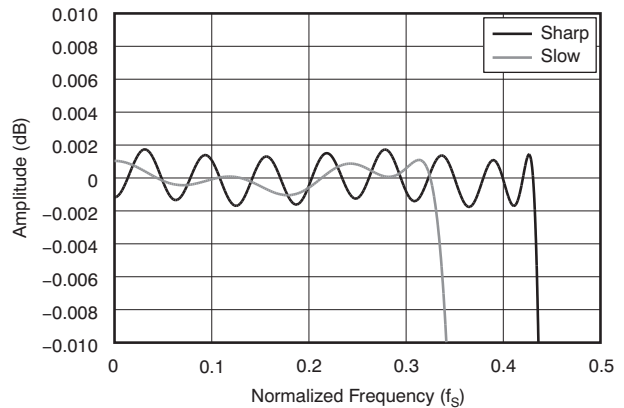

Figure 6.

TYPICAL CHARACTERISTICS: Digital De-Emphasis Filter

All specifications at $T_A = +25^\circ\text{C}$, $V_{CC1} = V_{CC2} = 5\text{ V}$, $V_{DD} = 3.3\text{ V}$, $f_S = 48\text{ kHz}$, $SCK1 = 512 f_S$, 24-bit data, and Sampling mode = Auto, unless otherwise noted.

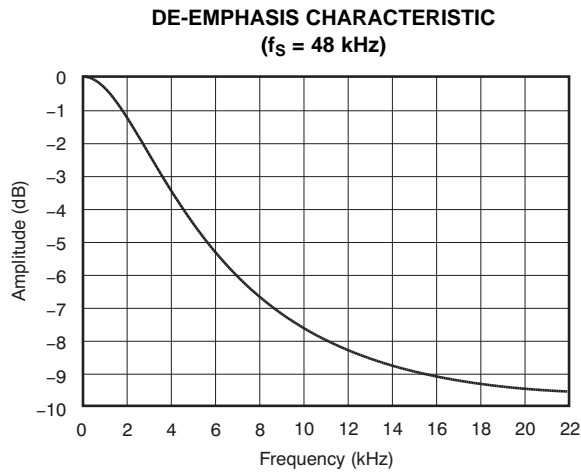

Figure 7.

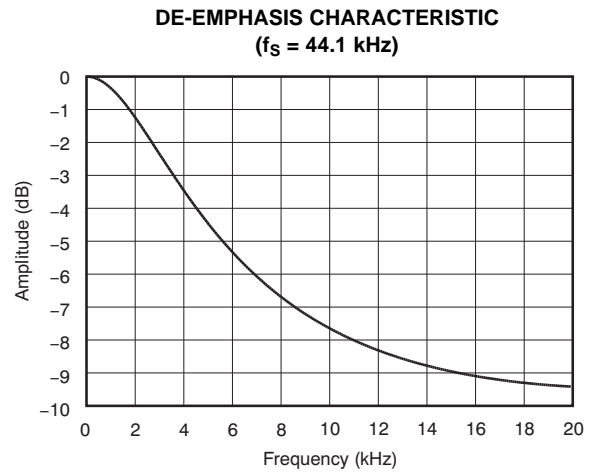

Figure 8.

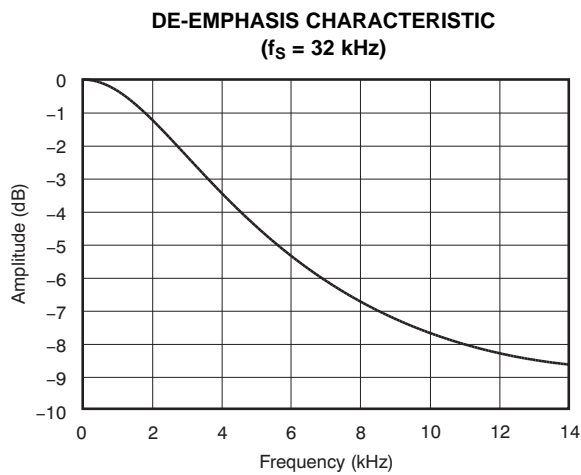

Figure 9.

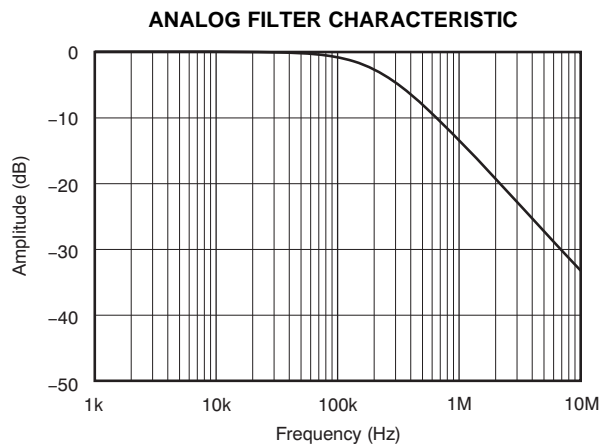

Figure 10.

TYPICAL CHARACTERISTICS: Dynamic Performance

All specifications at $T_A = +25^\circ\text{C}$, $V_{CC1} = V_{CC2} = 5\text{ V}$, $V_{DD} = 3.3\text{ V}$, $f_s = 48\text{ kHz}$, $SCKI = 512 f_s$, 24-bit data, and Sampling mode = Auto, unless otherwise noted.

**TOTAL HARMONIC DISTORTION + NOISE
vs
TEMPERATURE**

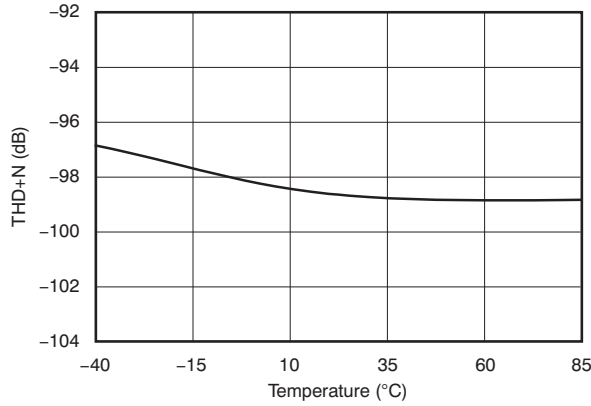

Figure 11.

**DYNAMIC RANGE AND SIGNAL-TO-NOISE RATIO
vs
TEMPERATURE**

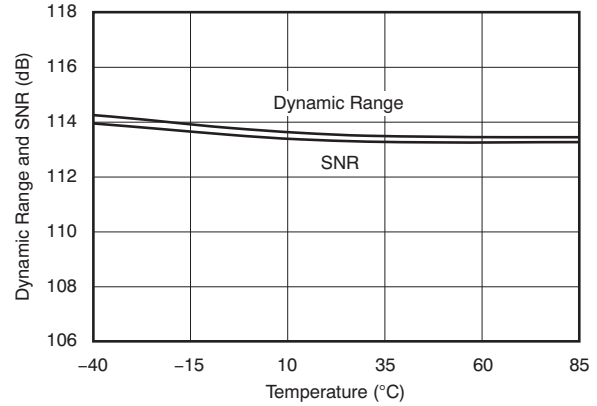

Figure 12.

**TOTAL HARMONIC DISTORTION + NOISE
vs
SUPPLY VOLTAGE**

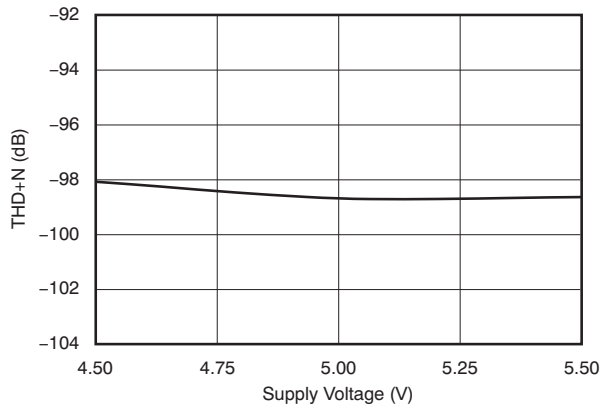

Figure 13.

**DYNAMIC RANGE AND SIGNAL-TO-NOISE RATIO
vs
SUPPLY VOLTAGE**

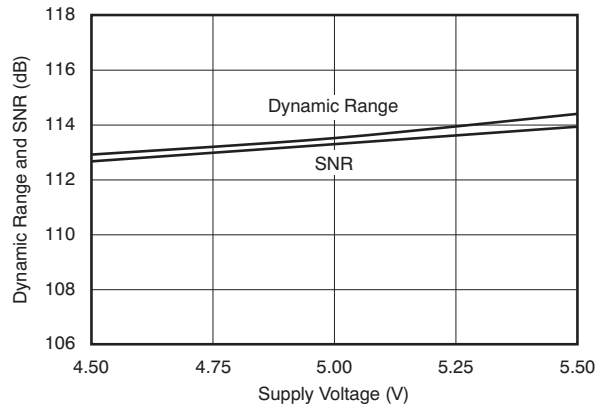

Figure 14.

TYPICAL CHARACTERISTICS: Output Spectrum

All specifications at $T_A = +25^\circ\text{C}$, $V_{CC1} = V_{CC2} = 5\text{ V}$, $V_{DD} = 3.3\text{ V}$, $f_S = 48\text{ kHz}$, $SCKI = 512 f_S$, 24-bit data, and Sampling mode = Auto, unless otherwise noted.

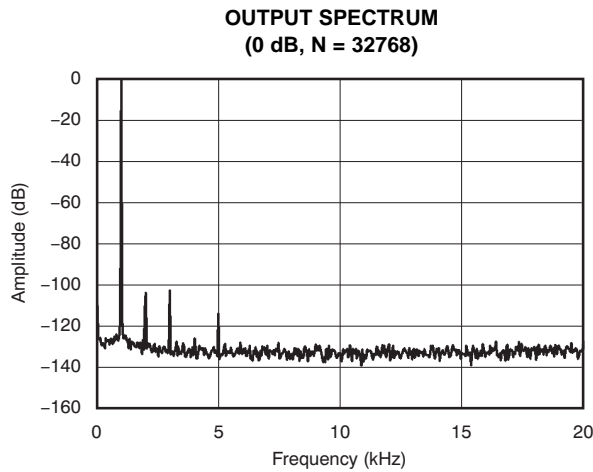

Figure 15.

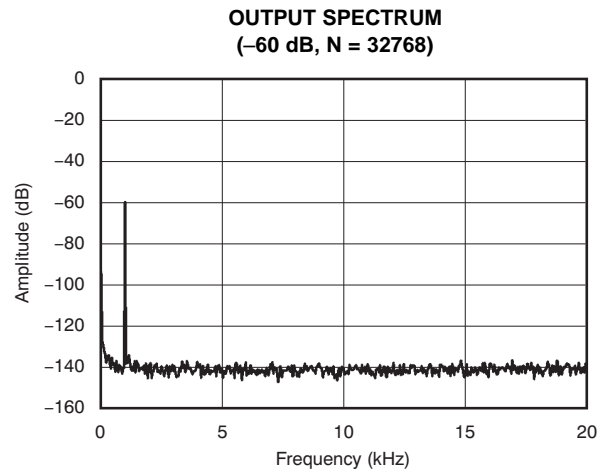

Figure 16.

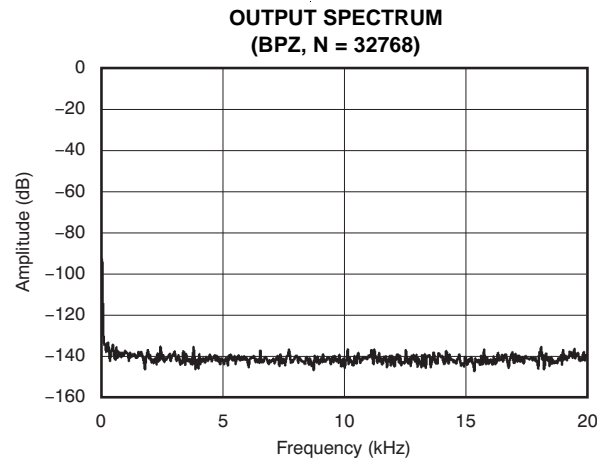

Figure 17.

PRODUCT OVERVIEW

The PCM1789-Q1 is a high-performance stereo DAC targeted for consumer audio applications such as Blu-ray Disc players and DVD players, as well as home multi-channel audio applications (such as home theater and A/V receivers). The PCM1789-Q1 consists of a two-channel DAC. The DAC output type is fixed with a differential configuration. The PCM1789-Q1 supports 16-/20-/24-/32-bit linear PCM input data in I²S and left-justified audio formats, and 24-bit linear PCM input data in right-justified and DSP formats with various sampling frequencies from 8 kHz to 192 kHz. The PCM1789-Q1 offers three modes for device control: two-wire I²C software, three-wire SPI software, and hardware.

ANALOG OUTPUTS

The PCM1789-Q1 includes a two-channel DAC, with a pair of differential voltage outputs pins. The full-scale output voltage is $(1.6 \times V_{CC1}) V_{PP}$ in differential output mode. A dc-coupled load is allowed in addition to an ac-coupled load, if the load resistance conforms to the specification. These balanced outputs are each capable of driving $0.8 V_{CC1}$ ($4 V_{PP}$) typical into a 5-k Ω ac-coupled or 15-k Ω dc-coupled load with $V_{CC1} = +5$ V. The internal output amplifiers for VOUTL and VOUTR are biased to the dc common voltage, equal to $0.5 V_{CC1}$.

The output amplifiers include an RC continuous-time filter that helps to reduce the out-of-band noise energy present at the DAC outputs as a result of the noise shaping characteristics of the PCM1789-Q1 delta-sigma ($\Delta\Sigma$) DACs. The frequency response of this filter is shown in the *Analog Filter Characteristic* (Figure 10) of the [Typical Characteristics](#). By itself, this filter is not enough to attenuate the out-of-band noise to an acceptable level for most applications. An external low-pass filter is required to provide sufficient out-of-band noise rejection. Further discussion of DAC post-filter circuits is provided in the [Application Information](#) section.

VOLTAGE REFERENCE VCOM

The PCM1789-Q1 includes a pin for the common-mode voltage output, VCOM. This pin should be connected to the analog ground via a decoupling capacitor. This pin can also be used to bias external high-impedance circuits, if they are required.

SYSTEM CLOCK INPUT

The PCM1789-Q1 requires an external system clock input applied at the SCKI input for DAC operation. The system clock operates at an integer multiple of the sampling frequency, or f_s . The multiples supported in DAC operation include $128 f_s$, $192 f_s$, $256 f_s$, $384 f_s$, $512 f_s$, $768 f_s$, and $1152 f_s$. Details for these system clock multiples are shown in [Table 1](#). [Figure 18](#) and [Table 2](#) show the SCKI timing requirements.

Table 1. System Clock Frequencies for Common Audio Sampling Rates

DEFAULT SAMPLING MODE	SAMPLING FREQUENCY, f_s (kHz)	SYSTEM CLOCK FREQUENCY (MHz)						
		$128 f_s$	$192 f_s$	$256 f_s$	$384 f_s$	$512 f_s$	$768 f_s$	$1152 f_s$
Single rate	8	N/A	N/A	2.0480	3.0720	4.0960	6.1440	9.2160
	16	2.0480	3.0720	4.0960	6.1440	8.1920	12.2880	18.4320
	32	4.0960	6.1440	8.1920	12.2880	16.3840	24.5760	36.8640
	44.1	5.6448	8.4672	11.2896	16.9344	22.5792	33.8688	N/A
	48	6.1440	9.2160	12.2880	18.4320	24.5760	36.8640	N/A
Dual rate	88.2	11.2896	16.9344	22.5792	33.8688	N/A	N/A	N/A
	96	12.2880	18.4320	24.5760	36.8640	N/A	N/A	N/A
Quad rate	176.4	22.5792	33.8688	N/A	N/A	N/A	N/A	N/A
	192	24.5760	36.8640	N/A	N/A	N/A	N/A	N/A

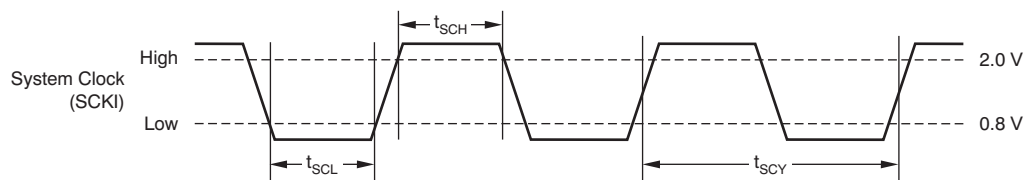

Figure 18. System Clock Timing Diagram

Table 2. Timing Requirements for [Figure 18](#)

SYMBOL	PARAMETER	MIN	MAX	UNIT
t_{SCY}	System clock cycle time	27		ns
t_{SCH}	System clock width high	10		ns
t_{SCL}	System clock width low	10		ns
—	System clock duty cycle	40	60	%

SAMPLING MODE

The PCM1789-Q1 supports three sampling modes (single rate, dual rate, and quad rate) in DAC operation. In single rate mode, the DAC operates at an oversampling frequency of x128 (except when SCKI = 128 f_S and 192 f_S); this mode is supported for sampling frequencies less than 50 kHz. In dual rate mode, the DAC operates at an oversampling frequency of x64; this mode is supported for sampling frequencies less than 100 kHz. In quad rate mode, the DAC operates at an oversampling frequency of x32. The sampling mode is automatically selected according to the ratio of system clock frequency and sampling frequency by default (that is, single rate for 512 f_S, 768 f_S, and 1152 f_S; dual rate for 256 f_S and 384 f_S; and quad rate for 128 f_S and 192 f_S), but manual selection is also possible for specified combinations through the serial mode control register.

Table 3 and Figure 19 show the relationship among the oversampling rate (OSR) of the digital filter and ΔΣ modulator, the noise-free shaped bandwidth, and each sampling mode setting.

Table 3. Digital Filter OSR, Modulator OSR, and Noise-Free Shaped Bandwidth for Each Sampling Mode

SAMPLING MODE REGISTER SETTING	SYSTEM CLOCK FREQUENCY (xf _S)	NOISE-FREE SHAPED BANDWIDTH ⁽¹⁾ (kHz)			DIGITAL FILTER OSR	MODULATOR OSR
		f _S = 48 kHz	f _S = 96 kHz	f _S = 192 kHz		
Auto	512, 768, 1152	40	N/A	N/A	x8	x128
	256, 384	20	40	N/A	x8	x64
	128, 192 ⁽²⁾	10	20	40	x4	x32
Single	512, 768, 1152	40	N/A	N/A	x8	x128
	256, 384	40	N/A	N/A	x8	x128
	128, 192 ⁽²⁾	20	N/A	N/A	x4	x64
Dual	256, 384	20	40	N/A	x8	x64
	128, 192 ⁽²⁾	20	40	N/A	x4	x64
Quad	128, 192 ⁽²⁾	10	20	40	x4	x32

- (1) Bandwidth in which noise is shaped out.
- (2) Quad mode filter characteristic is applied.

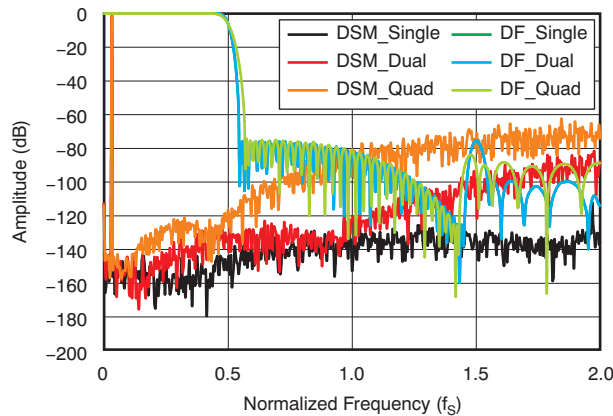

Figure 19. ΔΣ Modulator and Digital Filter Characteristic

RESET OPERATION

The PCM1789-Q1 has both an internal power-on reset circuit and an external reset circuit. The sequences for both reset circuits are shown in [Figure 20](#) and [Figure 21](#). [Figure 20](#) illustrates the timing at the internal power-on reset. Initialization is triggered automatically at the point where VDD exceeds 2.2 V typical, and the internal reset is released after 3846 SCKI clock cycles from power-on, if RST is held high and SCKI is provided. VOUTx from the DAC is forced to the VCOM level initially (that is, $0.5 \times VCC1$) and settles at a specified level according to the rising VCC. If synchronization among SCKI, BCK, and LRCK is maintained, VOUT provides an output that corresponds to DIN after 3846 SCKI clocks from power-on. If the synchronization is not held, the internal reset is not released, and both operating modes are maintained at reset and power-down states. After synchronization forms again, the DAC returns to normal operation with the previous sequences.

[Figure 21](#) illustrates a timing diagram at the external reset. RST accepts an externally-forced reset with RST low, and provides a device reset and power-down state that achieves the lowest power dissipation state available in the PCM1789-Q1. If RST goes from high to low under synchronization among SCKI, BCK, and LRCK, the internal reset is asserted, all registers and memory are reset, and finally, the PCM1789-Q1 enters into all power-down states. At the same time, VOUT is immediately forced into the AGND1 level. To begin normal operation again, toggle RST high; the same power-up sequence is performed as the power-on reset shown in [Figure 20](#).

The PCM1789-Q1 does not require particular power-on sequences for VCC and VDD; it allows VDD on and then VCC on, or VCC on and then VDD on. From the viewpoint of the [Absolute Maximum Ratings](#), however, simultaneous power-on is recommended for avoiding unexpected responses on VOUTx. [Figure 20](#) illustrates the response for VCC on with VDD on.

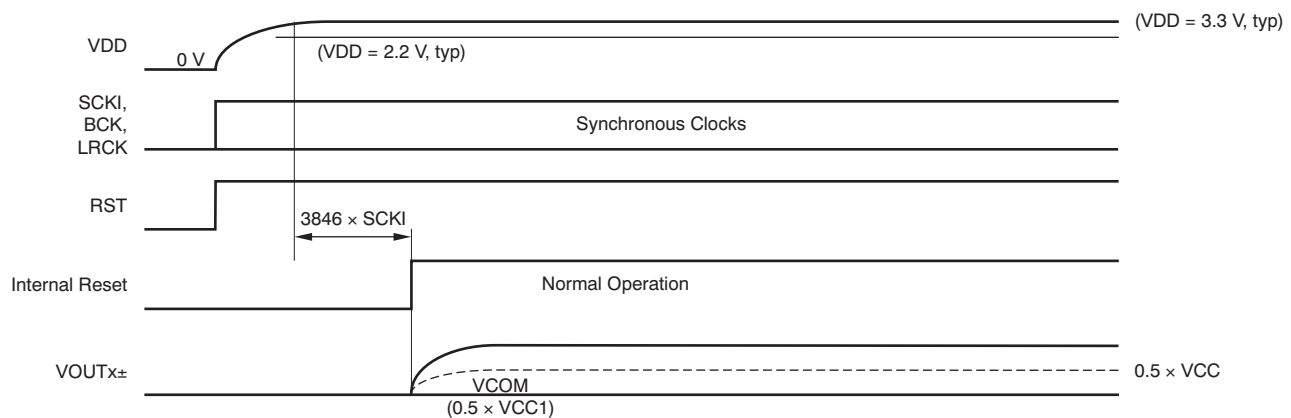

Figure 20. Power-On-Reset Timing Requirements

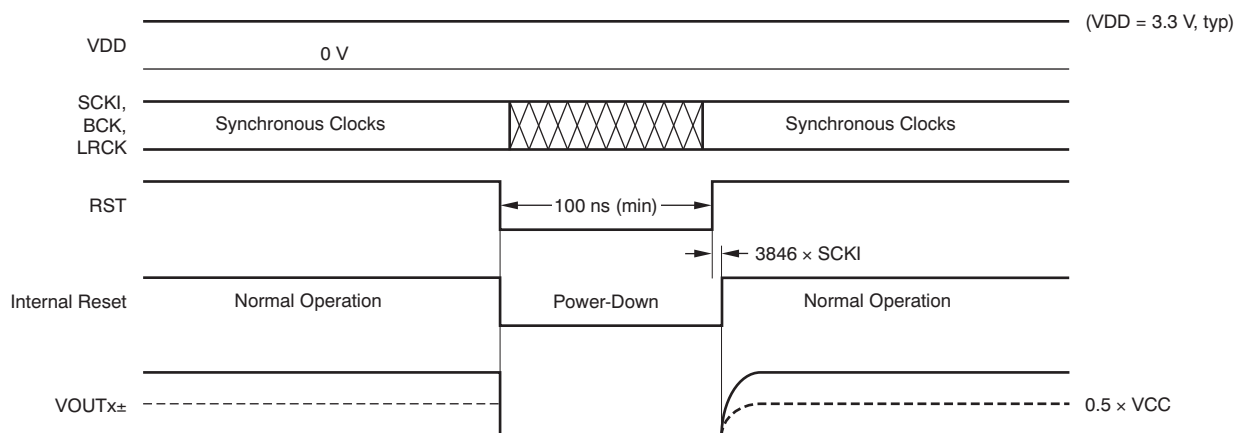

Figure 21. External Reset Timing Requirements

AUDIO SERIAL PORT OPERATION

The PCM1789-Q1 audio serial port consists of three signals: BCK, LRCK, and DIN. BCK is a bit clock input. LRCK is a left/right word clock or frame synchronization clock input. DIN is the audio data input for VOUTL/R.

AUDIO DATA INTERFACE FORMATS AND TIMING

The PCM1789-Q1 supports six audio data interface formats: 16-/20-/24-/32-bit I²S, 16-/20-/24-/32-bit left-justified, 24-bit right-justified, 16-bit right-justified, 24-bit left-justified mode DSP, and 24-bit I²S mode DSP. In the case of I²S, left-justified, and right-justified data formats, 64 BCKs, 48 BCKs, and 32 BCKs per LRCK period are supported; however, 48 BCKs are limited to 192/384/768 f_S SCKI, and 32 BCKs are limited to 16-bit right-justified only. The audio data formats are selected by MC/SCL/FMT in hardware control mode and by the FMTDA[2:0] bits in control register 17 (11h) in software control mode. All data must be in binary twos complement and MSB first.

Table 4 summarizes the applicable formats and describes the relationships among them and the respective restrictions with mode control. Figure 22 through Figure 26 show six audio interface data formats.

Table 4. Audio Data Interface Formats and Sampling Rate, Bit Clock, and System Clock Restrictions

CONTROL MODE	FORMAT	DATA BITS	MAX LRCK FREQUENCY (f _S)	SCKI RATE (xf _S)	BCK RATE (xf _S)
Software control	I ² S/Left-Justified	16/20/24/32 ⁽¹⁾	192 kHz	128 to 1152 ⁽²⁾	64, 48
	Right-Justified	24, 16	192 kHz	128 to 1152 ⁽²⁾	64, 48, 32 (16 bit) ⁽³⁾
	I ² S/Left-Justified DSP	24	192 kHz	128 to 768	64
Hardware control	I ² S/Left-Justified	16/20/24/32 ⁽¹⁾	192 kHz	128 to 1152 ⁽²⁾	64, 48

(1) 32-bit data length is acceptable only for BCK = 64 f_S and when using I²S or Left-Justified format.

(2) 1152 f_S is acceptable only for f_S = 32 kHz, BCK = 64 f_S, and when using I²S, Left-Justified, or 24-bit Right-Justified format.

(3) BCK = 32 f_S is supported only for 16-bit data length.

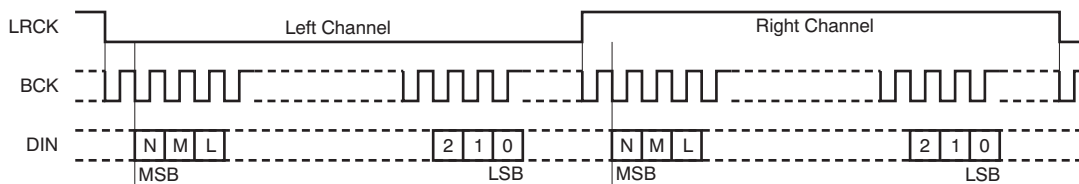

Figure 22. Audio Data Format: 16-/20-/24-/32-Bit I²S
(N = 15/19/23/31, M = 14/18/22/30, and L = 13/17/21/29)

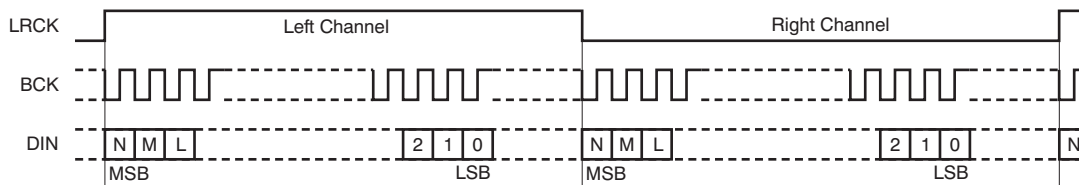

Figure 23. Audio Data Format: 16-/20-/24-/32-Bit Left-Justified
(N = 15/19/23/31, M = 14/18/22/30, and L = 13/17/21/29)

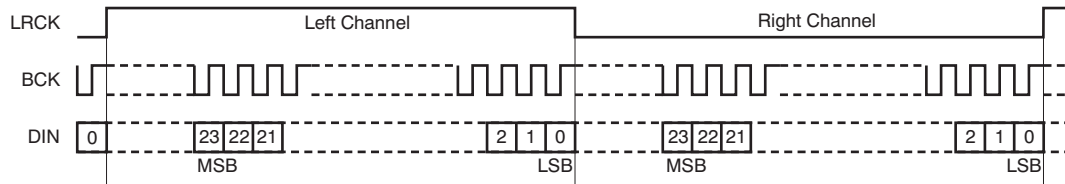

Figure 24. Audio Data Format: 24-Bit Right-Justified

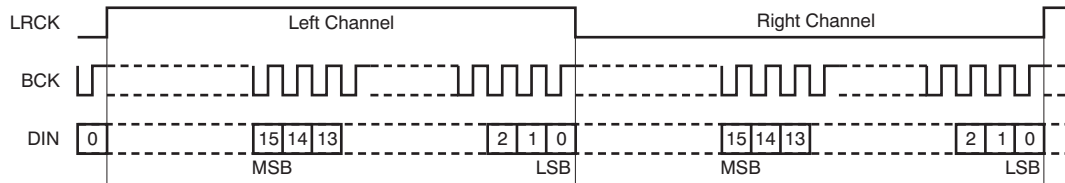

Figure 25. Audio Data Format: 16-Bit Right-Justified

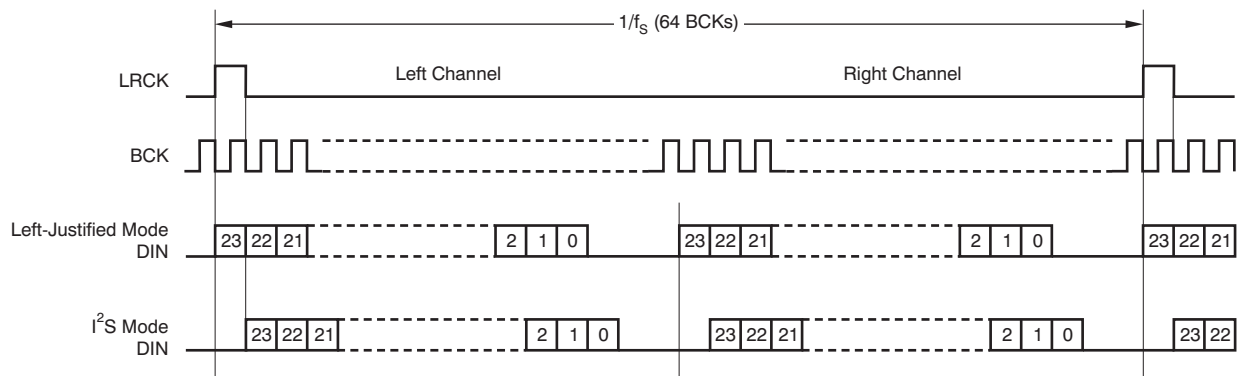

Figure 26. Audio Data Format: 24-Bit DSP Format

AUDIO INTERFACE TIMING

Figure 27 and Table 5 describe the detailed audio interface timing specifications.

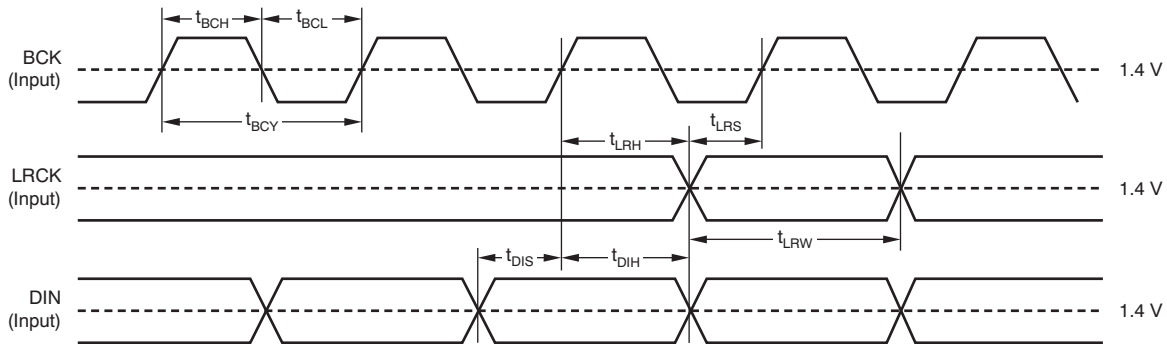

Figure 27. Audio Interface Timing Diagram for Left-Justified, Right-Justified, I²S, and DSP Data Formats

Table 5. Timing Requirements for Figure 27

SYMBOL	DESCRIPTION	MIN	TYP	MAX	UNIT
t_{BCY}	BCK cycle time	75			ns
t_{BCH}	BCK pulse width high	35			ns
t_{BCL}	BCK pulse width low	35			ns
t_{LRW}	LRCK pulse width high (LJ, RJ and I ² S formats)	$1/(2 \times f_S)$		$1/(2 \times f_S)$	sec
	LRCK pulse width high (DSP format)	t_{BCY}		t_{BCY}	sec
t_{LRS}	LRCK setup time to BCK rising edge	10			ns
t_{LRH}	LRCK hold time to BCK rising edge	10			ns
t_{DIS}	DIN setup time to BCK rising edge	10			ns
t_{DIH}	DIN hold time to BCK rising edge	10			ns

SYNCHRONIZATION WITH THE DIGITAL AUDIO SYSTEM

The PCM1789-Q1 operates under the system clock (SCKI) and the audio sampling rate (LRCK). Therefore, SCKI and LRCK must have a specific relationship. The PCM1789-Q1 does not need a specific phase relationship between the audio interface clocks (LRCK, BCK) and the system clock (SCKI), but does require a specific frequency relationship (ratiometric) between LRCK, BCK, and SCKI.

If the relationship between SCKI and LRCK changes more than ± 2 BCK clocks because of jitter, sampling frequency change, etc., the DAC internal operation stops within $1/f_s$, and the analog output is forced into VCOM ($0.5 V_{CC1}$) until re-synchronization among SCKI, LRCK, and BCK completes, and then either $38/f_s$ (single, dual rate) or $29/f_s$ (quad rate) passes. In the event the change is less than ± 2 BCKs, re-synchronization does not occur, and this analog output control and discontinuity does not occur.

Figure 28 shows the DAC analog output during loss of synchronization. During undefined data periods, some noise may be generated in the audio signal. Also, the transition of normal to undefined data and undefined (or zero) data to normal data creates a discontinuity of data on the analog outputs, which may then generate some noise in the audio signal.

The DAC outputs (V_{OUTx}) hold the previous state if the system clock halts, but the asynchronous and re-synchronization processes will occur after the system clock resumes.

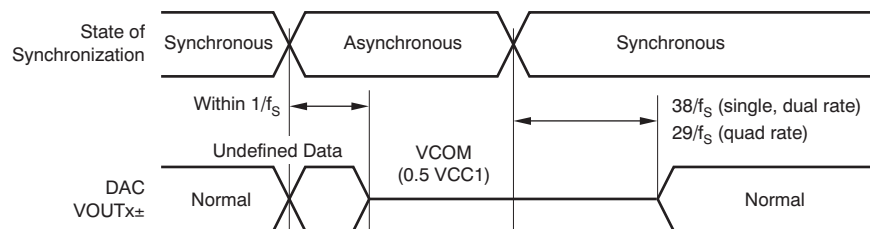

Figure 28. DAC Outputs During Loss of Synchronization

ZERO FLAG

The PCM1789-Q1 has two ZERO flag pins (ZERO1 and ZERO2) that can be assigned to the combinations shown in Table 6. Zero flag combinations are selected through the AZRO bit in control register 22 (16h). If the input data of all the assigned channels remain at '0' for 1024 sampling periods (LRCK clock periods), the ZERO1/2 bits are set to a high level, logic '1' state. Furthermore, if the input data of any of the assigned channels read '1', the ZERO1/2 are set to a low level, logic '0' state, immediately. Zero data detection is supported for 16-/20-/24-bit data width, but is not supported for 32-bit data width.

The active polarity of the zero flag output can be inverted through the ZREV bit in control register 22 (16h). The reset default is active high for zero detection.

In parallel hardware control mode, ZERO1 and ZERO2 are fixed with combination A, shown in Table 6.

Table 6. Zero Flag Outputs Combination

ZERO FLAG COMBINATION	ZERO1	ZERO2
A	Left channel	Right channel
B	Left channel or right channel	Left channel and right channel

Note that the ZERO2 pin is multiplexed with AMUTE0 pin. Selection of ZERO2 or AMUTE0 can be changed through the MZSEL bit in control register 22 (16h). The default setting after reset is the selection of ZERO2.

AMUTE CONTROL

The PCM1789-Q1 has an AMUTE control input, status output pins, and functionality. AMUTEI is the input control pin of the internal analog mute circuit. An AMUTEI low input causes the DAC output to cut-off from the digital input and forces it to the center level (0.5 VCC1). AMUTEO is the status output pin of the internal analog mute circuit. AMUTEO low indicates the analog mute control circuit is active because of a programmed condition (such as an SCKI halt, asynchronous detect, zero detect, or by the DAC disable command) that forces the DAC outputs to a center level. Because AMUTEI is not terminated internally and AMUTEO is an open-drain output, pull-ups by the appropriate resistors are required for proper operation.

Note that the AMUTEO pin is multiplexed with the ZERO2 pin. The desired pin is selected through the MZSEL bit in control register 22 (16h). The default setting is the selection of the ZERO2 pin.

Additionally, because the AMUTEI pin control and power-down control in register (OPEDA when high, PSMDA when low) do not function together, AMUTEI takes priority over power-down control. Therefore, power-down control is ignored during AMUTEI low, and AMUTEI low forces the DAC output to a center level (0.5 VCC1) even if power-down control is asserted.

MODE CONTROL

The PCM1789-Q1 includes three mode control interfaces with three oversampling configurations, depending on the input state of the MODE pin, as shown in [Table 7](#). The pull-up and pull-down resistors must be 220 kΩ ±5%.

Table 7. Interface Mode Control Selection

MODE	MODE CONTROL INTERFACE
Tied to DGND	Two-wire (I ² C) serial control, selectable oversampling configuration
Pull-down resistor to DGND	Two-wire parallel control, auto mode oversampling configuration
Pull-up resistor to VDD	Three-wire (SPI) serial control, selectable oversampling configuration, ADR6 = '0'
Tied to VDD	Three-wire (SPI) serial control, selectable oversampling configuration, ADR6 = '1'

The input state of the MODE pin is sampled at the moment of power-on, or during a low-to-high transition of the RST pin, with the system clock input. Therefore, input changes after reset are ignored until the next power-on or reset. From the mode control selection described in [Table 7](#), the functions of four pins are changed, as shown in [Table 8](#).

Table 8. Pin Functions for Interface Mode

PIN	PIN ASSIGNMENTS		
	SPI	I ² C	H/W
21	MD (input)	SDA (input/output)	DEMP (input)
22	MC (input)	SCL (input)	FMT (input)
23	MS (input)	ADR0 (input)	RSV (input, low)
24	ADR5 (input)	ADR1 (input)	RSV (input, low)

In serial mode control, the actual mode control is performed by register writes (and reads) through the SPI- or I²C-compatible serial control port. In parallel mode control, two specific functions are controlled directly through the high/low control of two specific pins, as described in the following section.

PARALLEL HARDWARE CONTROL

The functions shown in [Table 9](#) and [Table 10](#) are controlled by two pins, DEMP and FMT, in parallel hardware control mode. The DEMP pin controls the 44.1-kHz digital de-emphasis function of both channels. The FMT pin controls the audio interface format for both channels.

Table 9. DEMP Functionality

DEMP	DESCRIPTION
Low	De-emphasis off
High	44.1 kHz de-emphasis on

Table 10. FMT Functionality

FMT	DESCRIPTION
Low	16-/20-/24-/32-bit I ² S format
High	16-/20-/24-/32-bit left-justified format

THREE-WIRE (SPI) SERIAL CONTROL

The PCM1789-Q1 includes an SPI-compatible serial port that operates asynchronously with the audio serial interface. The control interface consists of MD/SDA/DEMP, MC/SCL/FMT, and MS/ADR0/RSV. MD is the serial data input used to program the mode control registers. MC is the serial bit clock that shifts the data into the control port. MS is the select input used to enable the mode control port.

CONTROL DATA WORD FORMAT

All single write operations via the serial control port use 16-bit data words. Figure 29 shows the control data word format. The first bit (fixed at '0') is for write operation. After the first bit are seven other bits, labeled ADR[6:0], that set the register address for the write operation. ADR6 is determined by the status of the MODE pin. ADR5 is determined by the state of the ADR5/ADR1/RSV pin. A maximum of four PCM1789-Q1s can be connected on the same bus at any one time. Each PCM1789-Q1 responds when receiving its own register address. The eight least significant bits (LSBs), D[7:0] on MD, contain the data to be written to the register address specified by ADR[6:0].

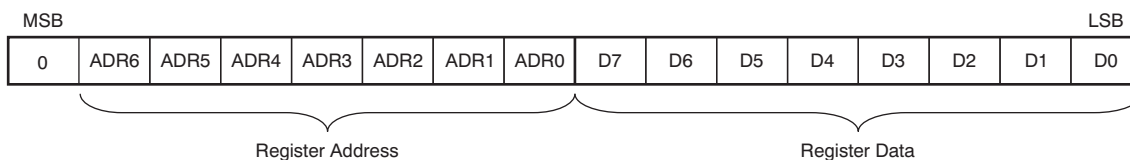
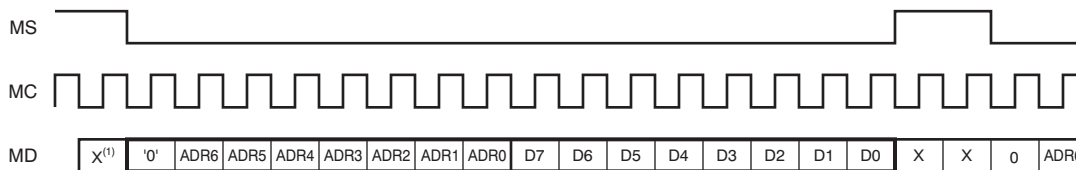

Figure 29. Control Data Word Format for MD

REGISTER WRITE OPERATION

Figure 30 shows the functional timing diagram for single write operations on the serial control port. MS is held at a high state until a register is to be written to. To start the register write cycle, MS is set to a low state. 16 clocks are then provided on MC, corresponding to the 16 bits of the control data word on MD. After the 16th clock cycle has been completed, MS is set high to latch the data into the indexed mode control register.

In addition to single write operations, the PCM1789-Q1 also supports multiple write operations, which can be performed by sending the N-bytes (where N ≤ 9) of the 8-bit register data that follow after the first 16-bit register address and register data, while keeping the MC clocks and MS at a low state. Ending a multiple write operation can be accomplished by setting MS to a high state.



(1) X = don't care.

Figure 30. Register Write Operation

TIMING REQUIREMENTS

Figure 31 shows a detailed timing diagram for the three-wire serial control interface. These timing parameters are critical for proper control port operation.

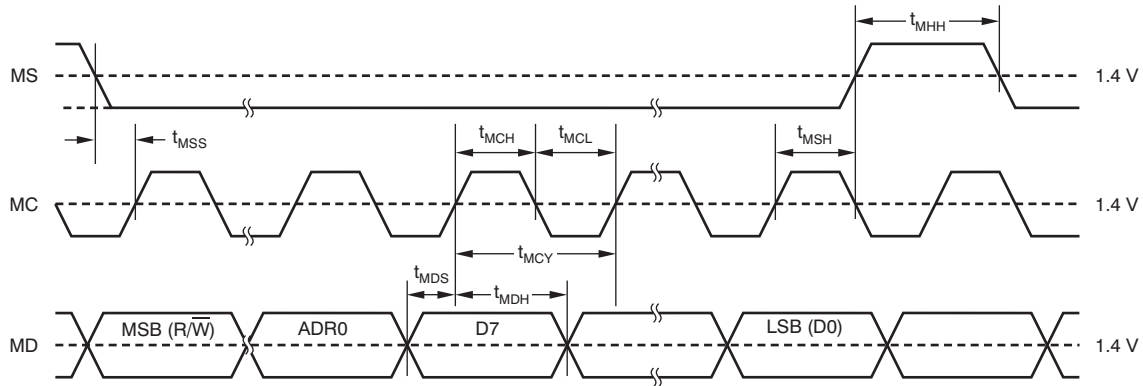

Figure 31. Three-Wire Serial Control Interface Timing

Table 11. Timing Requirements for Figure 31

SYMBOL	PARAMETER	MIN	MAX	UNIT
t_{MCY}	MC pulse cycle time	100		ns
t_{MCL}	MC low-level time	40		ns
t_{MCH}	MC high-level time	40		ns
t_{MHH}	MS high-level time	t_{MCY}		ns
t_{MSS}	MS falling edge to MC rising edge	30		ns
t_{MSH}	MS rising edge from MC rising edge for LSB	15		ns
t_{MDH}	MD hold time	15		ns
t_{MDS}	MD setup time	15		ns

TWO-WIRE (I²C) SERIAL CONTROL

The PCM1789-Q1 supports an I²C-compatible serial bus and data transmission protocol for fast mode configured as a slave device. This protocol is explained in the I²C specification 2.0.

The PCM1789-Q1 has a 7-bit slave address, as shown in Figure 32. The first five bits are the most significant bits (MSBs) of the slave address and are factory-preset to '10011'. The next two bits of the address byte are selectable bits that can be set by MS/ADR0/RSV and ADR5/ADR1/RSV. A maximum of four PCM1789-Q1s can be connected on the same bus at any one time. Each PCM1789-Q1 responds when it receives its own slave address.

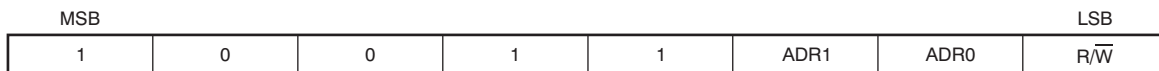
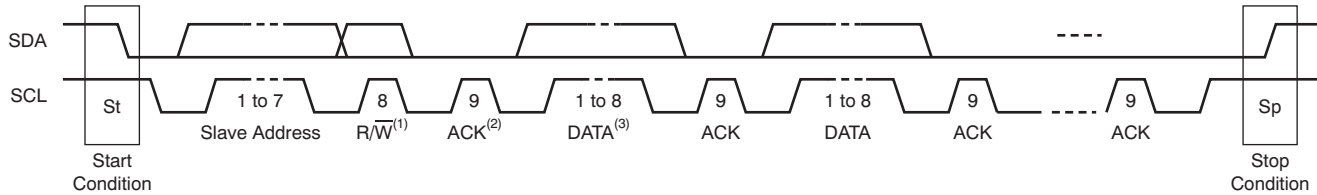

Figure 32. Slave Address

PACKET PROTOCOL

A master device must control the packet protocol, which consists of a start condition, a slave address with the read/write bit, data if a write operation is required, an acknowledgment if a read operation is required, and a stop condition. The PCM1789-Q1 supports both slave receiver and transmitter functions. Details about DATA for both write and read operations are described in [Figure 33](#).



- (1) R/\bar{W} : Read operation if '1'; write operation otherwise.
- (2) ACK: Acknowledgment of a byte if '0', not Acknowledgment of a byte if '1'.
- (3) DATA: Eight bits (byte); details are described in the [Write Operation](#) and [Read Operation](#) sections.

Figure 33. I²C Packet Control Protocol

WRITE OPERATION

The PCM1789-Q1 supports a receiver function. A master device can write to any PCM1789-Q1 register using single or multiple accesses. The master sends a PCM1789-Q1 slave address with a write bit, a register address, and the data. If multiple access is required, the address is that of the starting register, followed by the data to be transferred. When valid data are received, the index register automatically increments by one. When the register address reaches &h4F, the next value is &h40. When undefined registers are accessed, the PCM1789-Q1 does not send an acknowledgment. [Figure 34](#) illustrates a diagram of the write operation. The register address and write data are in 8-bit, MSB-first format.

Transmitter	M	M	M	S	M	S	M	S	M	S		S	M
Data Type	St	Slave Address	\bar{W}	ACK	Reg Address	ACK	Write Data 1	ACK	Write Data 2	ACK		ACK	Sp

NOTE: M = Master device, S = Slave device, St = Start condition, \bar{W} = Write, ACK = Acknowledge, and Sp = Stop condition.

Figure 34. Framework for Write Operation

READ OPERATION

A master device can read the registers of the PCM1789-Q1. The value of the register address is stored in an indirect index register in advance. The master sends the PCM1789-Q1 slave address with a read bit after storing the register address. Then the PCM1789-Q1 transfers the data that the index register points to. [Figure 35](#) shows a diagram of the read operation.

Transmitter	M	M	M	S	M	S	M	M	M	S	S	M	M
Data Type	St	Slave Address	\bar{W}	ACK	Reg Address	ACK	Sr	Slave Address ⁽¹⁾	R	ACK	Read Data	NACK	Sp

- (1) The slave address after the repeated start condition must be the same as the previous slave address.

NOTE: M = Master device, S = Slave device, St = Start condition, Sr = Repeated start condition, \bar{W} = Write, R = Read, ACK = Acknowledge, NACK = Not acknowledge, and Sp = Stop condition.

Figure 35. Framework for Read Operation

TIMING REQUIREMENTS: SCL AND SDA

A detailed timing diagram for SCL and SDA is shown in [Figure 36](#).

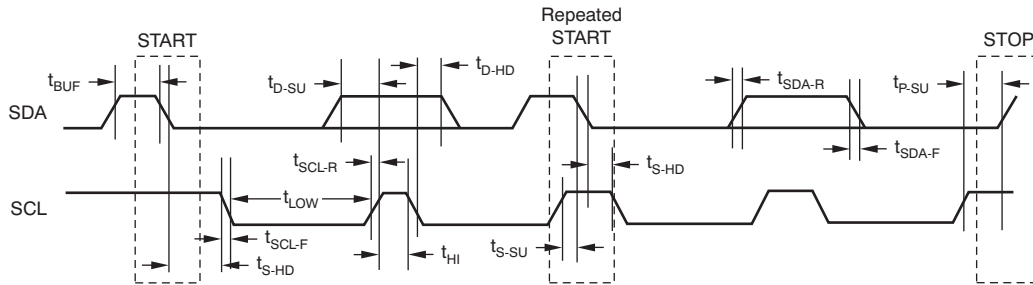

Figure 36. SCL and SDA Control Interface Timing

Table 12. Timing Requirements for [Figure 36](#)

SYMBOL	PARAMETER	STANDARD MODE		FAST MODE		UNIT
		MIN	MAX	MIN	MAX	
f_{SCL}	SCL clock frequency		100		400	kHz
t_{BUF}	Bus free time between STOP and START condition	4.7		1.3		μs
t_{LOW}	Low period of the SCL clock	4.7		1.3		μs
t_{HI}	High period of the SCL clock	4.0		0.6		μs
t_{S-SU}	Setup time for START/Repeated START condition	4.7		0.6		μs
t_{S-HD}	Hold time for START/Repeated START condition	4.0		0.6		μs
t_{D-SU}	Data setup time	250		100		ns
t_{D-HD}	Data hold time	0	3450	0	900	ns
t_{SCL-R}	Rise time of SCL signal		1000	$20 + 0.1 C_B$	300	ns
t_{SCL-F}	Fall time of SCL signal		1000	$20 + 0.1 C_B$	300	ns
t_{SDA-R}	Rise time of SDA signal		1000	$20 + 0.1 C_B$	300	ns
t_{SDA-F}	Fall time of SDA signal		1000	$20 + 0.1 C_B$	300	ns
t_{P-SU}	Setup time for STOP condition	4.0		0.6		μs
t_{GW}	Allowable glitch width		N/A		50	ns
C_B	Capacitive load for SDA and SCL line		400		100	pF
V_{NH}	Noise margin at high level for each connected device (including hysteresis)	$0.2 \times V_{DD}$		$0.2 \times V_{DD}$		V
V_{NL}	Noise margin at low level for each connected device (including hysteresis)	$0.1 \times V_{DD}$		$0.1 \times V_{DD}$		V
V_{HYS}	Hysteresis of Schmitt trigger input	N/A		$0.05 \times V_{DD}$		V

CONTROL REGISTER DEFINITIONS (SOFTWARE MODE ONLY)

The PCM1789-Q1 has many user-programmable functions that are accessed via control registers, and are programmed through the SPI or I²C serial control port. Table 13 shows the available mode control functions along with reset default conditions and associated register addresses. Table 14 lists the register map.

Table 13. User-Programmable Mode Control Functions

FUNCTION	RESET DEFAULT	REGISTER ⁽¹⁾	LABEL
Mode control register reset	Normal operation	16	MRST
System reset	Normal operation	16	SRST
Analog mute function control	Mute disabled	16	AMUTE[3:0]
Sampling mode selection	Auto	16	SRDA[1:0]
Power-save mode selection	Power save	17	PSMDA
Audio interface format selection	I ² S	17	FMTDA[2:0]
Operation control	Normal operation	18	OPEDA
Digital filter roll-off control	Sharp roll-off	18	FLT
Output phase selection	Normal	19	REVDA[2:1]
Soft mute control	Mute disabled	20	MUTDA[2:1]
Zero flag	Not detected	21	ZERO[2:1]
Digital attenuation mode	0 dB to –63 dB, 0.5-dB step	22	DAMS
Digital de-emphasis function control	Disabled	22	DEMP[1:0]
AMUTE0/ZERO flag selection	ZERO2	22	MZSEL
Zero flag function selection	ZERO1: left-channel ZERO2: right-channel	22	AZRO
Zero flag polarity selection	High for detection	22	ZREV
Digital attenuation level setting	0 dB, no attenuation	24, 25	ATDAX[7:0]

(1) If ADR6 or ADR5 is high, the register address must be changed to the number shown + offset; offset is 32, 64 and 96 according to state of ADR6, 5 (01, 10 and 11).

Table 14. Register Map

ADR[6:0] ⁽¹⁾		DATA[7:0]							
DEC	HEX	B7	B6	B5	B4	B3	B2	B1	B0
16	10	MRST	SRST	AMUTE3	AMUTE2	AMUTE1	AMUTE0	SRDA1	SRDA0
17	11	PSMDA	RSV ⁽²⁾	RSV ⁽²⁾	RSV ⁽²⁾	RSV ⁽²⁾	FMTDA2	FMTDA1	FMTDA0
18	12	RSV ⁽²⁾	RSV ⁽²⁾	RSV ⁽²⁾	OPEDA	RSV ⁽²⁾	RSV ⁽²⁾	RSV ⁽²⁾	FLT
19	13	RSV ⁽²⁾	RSV ⁽²⁾	RSV ⁽²⁾	RSV ⁽²⁾	RSV ⁽²⁾	RSV ⁽²⁾	REVDA2	REVDA1
20	14	RSV ⁽²⁾	RSV ⁽²⁾	RSV ⁽²⁾	RSV ⁽²⁾	RSV ⁽²⁾	RSV ⁽²⁾	MUTDA2	MUTDA1
21	15	RSV ⁽²⁾	RSV ⁽²⁾	RSV ⁽²⁾	RSV ⁽²⁾	RSV ⁽²⁾	RSV ⁽²⁾	ZERO2	ZERO1
22	16	DAMS	RSV ⁽²⁾	DEMP1	DEMP0	MZSEL	RSV ⁽²⁾	AZRO	ZREV
23	17	RSV ⁽²⁾	RSV ⁽²⁾	RSV ⁽²⁾	RSV ⁽²⁾	RSV ⁽²⁾	RSV ⁽²⁾	RSV ⁽²⁾	RSV ⁽²⁾
24	18	ATDA17	ATDA16	ATDA15	ATDA14	ATDA13	ATDA12	ATDA11	ATDA10
25	19	ATDA27	ATDA26	ATDA25	ATDA24	ATDA23	ATDA22	ATDA21	ATDA20

(1) If ADR6 or ADR5 is high, the register address must be changed to the number shown + offset; offset is 32, 64 and 96 according to state of ADR6, 5 (01, 10 and 11).

(2) RSV must be set to '0'.

REGISTER DEFINITIONS

DEC	HEX	B7	B6	B5	B4	B3	B2	B1	B0
16	10	MRST	SRST	AMUTE3	AMUTE2	AMUTE1	AMUTE0	SRDA1	SRDA0

MRST Mode control register reset

This bit sets the mode control register reset to the default value. Pop noise may be generated. Returning the MRST bit to '1' is unnecessary because it is automatically set to '1' after the mode control register is reset.

Default value = 1.

MRST Mode control register reset

0	Set default value
1	Normal operation (default)

SRST System reset

This bit controls the system reset, which includes the resynchronization between the system clock and sampling clock, and DAC operation restart. The mode control register is not reset and the PCM1789-Q1 does not go into a power-down state. Returning the SRST bit to '1' is unnecessary; it is automatically set to '1' after triggering a system reset.

Default value = 1.

SRST System reset

0	Resynchronization
1	Normal operation (default)

AMUTE[3:0] Analog mute function control

These bits control the enabling/disabling of each source event that triggers the analog mute control circuit.

Default value = 0000.

AMUTE Analog mute function control

xxx0	Disable analog mute control by SCKI halt
xxx1	Enable analog mute control by SCKI halt
xx0x	Disable analog mute control by asynchronous detect
xx1x	Enable analog mute control by asynchronous detect
x0xx	Disable analog mute control by ZERO1 and ZERO2 detect
x1xx	Enable analog mute control by ZERO1 and ZERO2 detect
0xxx	Disable analog mute control by DAC disable command
1xxx	Enable analog mute control by DAC disable command

SRDA[1:0] Sampling mode selection

These bits control the sampling mode of DAC operation. In Auto mode, the sampling mode is automatically set according to multiples between the system clock and sampling clock: single rate for $512 f_s$, $768 f_s$, and $1152 f_s$, dual rate for $256 f_s$ or $384 f_s$, and quad rate for $128 f_s$ and $192 f_s$.

Default value = 00.

SRDA Sampling mode selection

00	Auto (default)
01	Single rate
10	Dual rate
11	Quad rate

DEC	HEX	B7	B6	B5	B4	B3	B2	B1	B0
17	11	PSMDA	RSV	RSV	RSV	RSV	FMTDA2	FMTDA1	FMTDA0

PSMDA Power-save mode selection

This bit selects the power-save mode for the OPEDA function. When PSMDA = 0, OPEDA controls the power-save mode and normal operation. When PSMDA = 1, OPEDA functions controls the DAC disable (not power-save mode) and normal operation.

Default value: 0.

PSMDA Power-save mode selection

0	Power-save enable mode (default)
1	Power-save disable mode

RSV Reserved

Reserved; do not use.

FMTDA[2:0] Audio interface format selection

These bits control the audio interface format for DAC operation. Details of the format and any related restrictions with the system clock are described in the [Audio Data Interface Formats and Timing](#) section.

Default value: 0000 (16-/20-/24-/32-bit I²S format).

FMTDA Audio interface format selection

000	16-/20-/24-/32-bit I ² S format (default)
001	16-/20-/24-/32-bit left-justified format
010	24-bit right-justified format
011	16-bit right-justified format
100	24-bit I ² S mode DSP format
101	24-bit left-justified mode DSP format
110	Reserved
111	Reserved

DEC	HEX	B7	B6	B5	B4	B3	B2	B1	B0
18	12	RSV	RSV	RSV	OPEDA	RSV	RSV	RSV	FLT

RSV **Reserved**

Reserved; do not use.

OPEDA **Operation control**

This bit controls the DAC operation mode. In operation disable mode, the DAC output is cut off from DIN and the internal DAC data are reset. If PSMDA = 1, the DAC output is forced into VCOM. If PSMDA = 0, the DAC output is forced into AGND and the DAC goes into a power-down state. For normal operating mode, this bit must be '0'. The serial mode control is effective during operation disable mode.

Default value: 0.

OPEDA **Operation control**

- | | |
|---|--|
| 0 | Normal operation |
| 1 | Operation disable with or without power save |

FLT **Digital filter roll-off control**

This bit allows users to select the digital filter roll-off that is best suited to their applications. Sharp and slow filter roll-off selections are available. The filter responses for these selections are shown in the [Typical Characteristics](#) sections of this data sheet.

Default value: 0.

FLT **Digital filter roll-off control**

- | | |
|---|----------------|
| 0 | Sharp roll-off |
| 1 | Slow roll-off |

DEC	HEX	B7	B6	B5	B4	B3	B2	B1	B0
19	13	RSV	RSV	RSV	RSV	RSV	RSV	REVDA2	REVDA1

RSV **Reserved**

Reserved; do not use.

REVDA[2:1] **Output phase selection**

These bits are used to control the phase of the DAC analog signal outputs.

Default value: 00.

REVDA **Output phase selection**

- | | |
|----|-------------------------------|
| x0 | Left channel normal output |
| x1 | Left channel inverted output |
| 0x | Right channel normal output |
| 1x | Right channel inverted output |

DEC	HEX	B7	B6	B5	B4	B3	B2	B1	B0
20	14	RSV	RSV	RSV	RSV	RSV	RSV	MUTDA2	MUTDA1

RSV **Reserved**

Reserved; do not use.

MUTDA[2:1] Soft Mute control

These bits are used to enable or disable the Soft Mute function for the corresponding DAC outputs, VOUTx. The Soft Mute function is incorporated into the digital attenuators. When mute is disabled (MUTDA[2:1] = 0), the attenuator and DAC operate normally. When mute is enabled by setting MUTDA[2:1] = 1, the digital attenuator for the corresponding output is decreased from the current setting to infinite attenuation. By setting MUTDA[2:1] = 0, the attenuator is increased to the last attenuation level in the same manner as it is for decreasing levels. This configuration reduces *pop and zipper noise* during muting of the DAC output. This Soft Mute control uses the same resource of digital attenuation level setting. Mute control has priority over the digital attenuation level setting.

Default value: 00.

MUTDA Soft Mute control

x0	Left channel mute disabled
x1	Left channel mute enabled
0x	Right channel mute disabled
1x	Right channel mute enabled

DEC	HEX	B7	B6	B5	B4	B3	B2	B1	B0
21	15	RSV	RSV	RSV	RSV	RSV	RSV	ZERO2	ZERO1

RSV **Reserved**

Reserved; do not use.

ZERO[2:1] Zero flag (read-only)

These bits indicate the present status of the zero detect circuit for each DAC channel; these bits are read-only.

ZERO Zero flag

x0	Left channel zero input not detected
x1	Left channel zero input detected
0x	Right channel zero input not detected
1x	Right channel zero input detected

DEC	HEX	B7	B6	B5	B4	B3	B2	B1	B0
22	16	DAMS	RSV	DEMP1	DEMP0	MZSEL	RSV	AZRO	ZREV

DAMS Digital attenuation mode

This bit selects the attenuation mode.

Default value: 0.

DAMS Digital attenuation mode

- | | |
|---|---|
| 0 | Fine step: 0.5-dB step for 0 dB to –63 dB range (default) |
| 1 | Wide range: 1-dB step for 0 dB to –100 dB range |

RSV Reserved

Reserved; do not use.

DEMP[1:0] Digital de-emphasis function/sampling rate control

These bits are used to disable and enable the various sampling frequencies of the digital de-emphasis function.

Default value: 00.

DEMP Digital de-emphasis function/sampling rate control

- | | |
|----|-------------------|
| 00 | Disable (default) |
| 01 | 48 kHz enable |
| 10 | 44.1 kHz enable |
| 11 | 32 kHz enable |

MZSEL AMUTE0/ZERO flag selection

This bit is used to select the function of the ZERO2 pin.

Default value: 0.

MZSEL AMUTE0/ZERO flag selection

- | | |
|---|---|
| 0 | The ZERO2 pin functions as ZERO2 (default). |
| 1 | The ZERO2 pin functions as AMUTE0. |

AZRO Zero flag channel combination selection

This bit is used to select the zero flag channel combination for ZERO1 and ZERO2.

Default value: 0.

AZRO Zero flag combination selection

- | | |
|---|--|
| 0 | Combination A: ZERO1 = left channel, ZERO2 = right channel (default) |
| 1 | Combination B: ZERO1 = left channel or right channel, ZERO2 = left channel and right channel |

ZREV Zero flag polarity selection

This bit controls the polarity of the zero flag pin.

Default value: 0.

ZREV Zero flag polarity selection

- | | |
|---|--------------------------------|
| 0 | High for zero detect (default) |
| 1 | Low for zero detect |

DEC	HEX	B7	B6	B5	B4	B3	B2	B1	B0
23	17	RSV	RSV	RSV	RSV	RSV	RSV	RSV	RSV
24	18	ATDA17	ATDA16	ATDA15	ATDA14	ATDA13	ATDA12	ATDA11	ATDA10
25	19	ATDA27	ATDA26	ATDA25	ATDA24	ATDA23	ATDA22	ATDA21	ATDA20

RSV Reserved

Reserved; do not use.

ATDAx[7:0] Digital attenuation level setting

Where $x = 1$ to 2, corresponding to the DAC output (VOUTx).

Both DAC outputs (VOUTL and VOUTR) have a digital attenuation function. The attenuation level can be set from 0 dB to R dB, in S-dB steps. Changes in attenuator levels are made by incrementing or decrementing one step (S dB) for every $8/f_S$ time interval until the programmed attenuator setting is reached. Alternatively, the attenuation level can be set to infinite attenuation (or mute). R (range) and S (step) is –63 and 0.5 for DAMS = 0, and –100 and 1.0 for DAMS = 1, respectively. The DAMS bit is defined in register 22 (16h). [Table 15](#) shows attenuation levels for various settings.

The attenuation level for each channel can be set individually using the following formula:

$$\text{Attenuation level (dB)} = S \times (\text{ATDAx}[7:0]_{\text{DEC}} - 255)$$

where $\text{ATDAx}[7:0]_{\text{DEC}} = 0$ through 255.

For $\text{ATDAx}[7:0]_{\text{DEC}} = 0$ through 128 with DAMS = 0, or 0 through 154 with DAMS = 1, attenuation is set to infinite attenuation (mute).

Default value: 1111 1111.

Table 15. Attenuation Levels for Various Settings

ATDAx[7:0]		ATTENUATION LEVEL SETTING	
BINARY	DECIMAL	DAMS = 0	DAMS = 1
1111 1111	255	0 dB, no attenuation (default)	0 dB, no attenuation (default)
1111 1110	254	–0.5 dB	–1 dB
1111 1101	253	–1.0 dB	–2 dB
...
1001 1100	156	–45.9 dB	–99 dB
1001 1011	155	–50.0 dB	–100 dB
1001 1010	154	–50.5 dB	Mute
...
1000 0010	130	–62.5 dB	Mute
1000 0001	129	–63.0 dB	Mute
0000 0000	128	Mute	Mute
...
0000 0000	0	Mute	Mute

APPLICATION INFORMATION

CONNECTION DIAGRAMS

A basic connection diagram is shown in [Figure 37](#), with the necessary power-supply bypassing and decoupling components. Texas Instruments' [PLL170X](#) is used to generate the system clock input at SCKI, as well as to generate the clock for the audio signal processor. The use of series resistors (22 Ω to 100 Ω) are recommended for SCKI, LRCK, BCK, and DIN for electromagnetic interference (EMI) reduction.

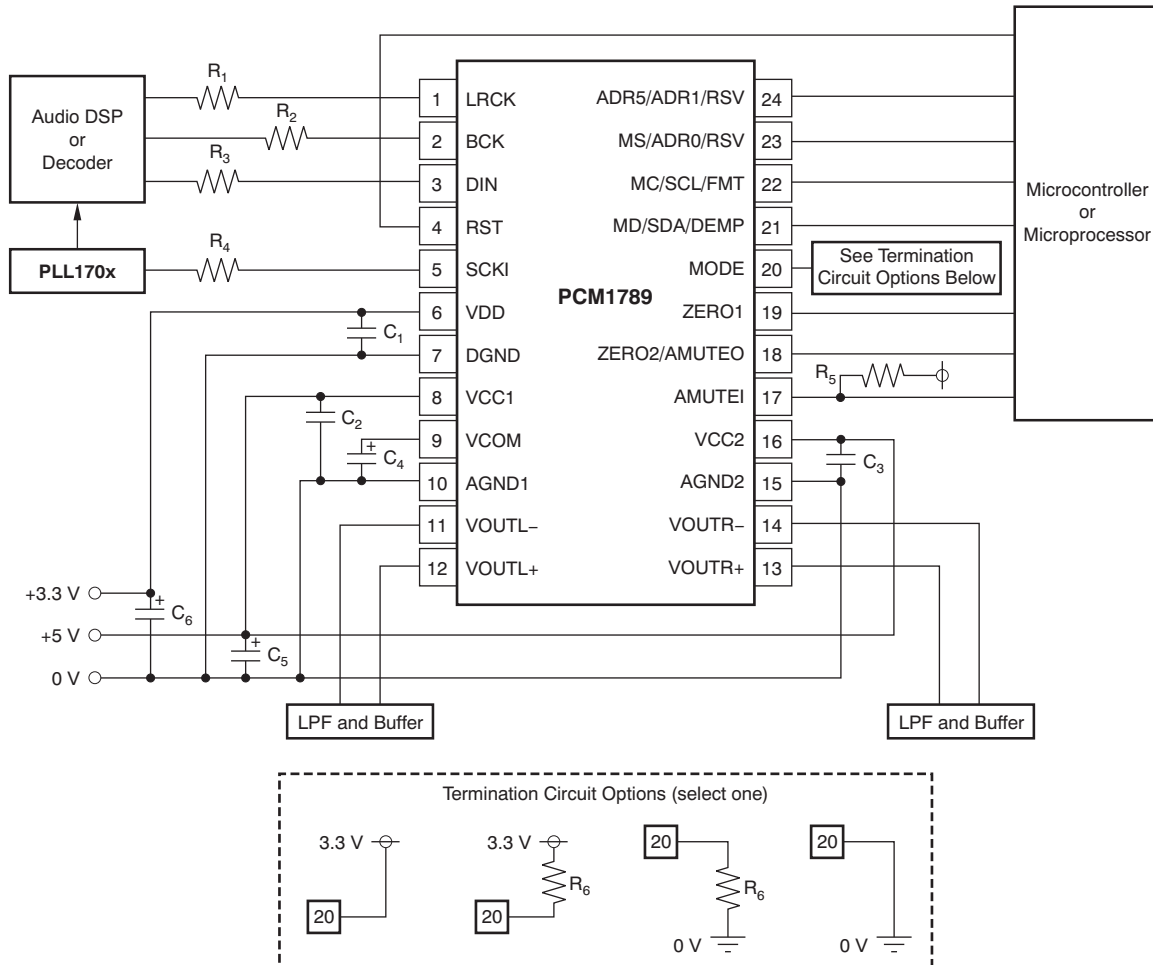

NOTE: C_1 through C_3 are 1- μ F ceramic capacitors. C_4 through C_6 are 10- μ F electrolytic capacitors. R_1 through R_4 are 22- Ω to 100- Ω resistors. R_5 is a resistor appropriate for pull-up. R_6 is a 220-k Ω resistor, $\pm 5\%$. An appropriate resistor is required for pull-up, if ZERO2/AMUTE0 pin is used as AMUTE0.

Figure 37. Basic Connection Diagram

POWER SUPPLY AND GROUNDING

The PCM1789-Q1 requires +5 V for the analog supply and +3.3 V for the digital supply. The +5-V supply is used to power the DAC analog and output filter circuitry, and the +3.3-V supply is used to power the digital filter and serial interface circuitry. For best performance, it is recommended to use a linear regulator (such as the [REG101-5/33](#), [REG102-5/33](#), or [REG103-5/33](#)) with the +5-V and +3.3-V supplies.

Five capacitors are required for supply bypassing, as shown in [Figure 37](#). These capacitors should be located as close as possible to the PCM1789-Q1 package. The 10- μ F capacitors are aluminum electrolytic, while the three 1- μ F capacitors are ceramic.

LOW-PASS FILTER AND DIFFERENTIAL-TO-SINGLE-ENDED CONVERTER FOR DAC OUTPUTS

$\Delta\Sigma$ DACs use noise-shaping techniques to improve in-band signal-to-noise ratio (SNR) performance at the expense of generating increased out-of-band noise above the Nyquist frequency, or $f_s/2$. The out-of-band noise must be low-pass filtered in order to provide optimal converter performance. This filtering is accomplished by a combination of on-chip and external low-pass filters.

Figure 38 and Figure 39 show the recommended external differential-to-single-ended converter with low-pass active filter circuits for ac-coupled and dc-coupled applications. These circuits are second-order Butterworth filters using a multiple feedback (MFB) circuit arrangement that reduces sensitivity to passive component variations over frequency and temperature. For more information regarding MFB active filter designs, please refer to Applications Bulletin [SBAA055](#), *Dynamic Performance Testing of Digital Audio D/A Converters*, available from the TI web site (www.ti.com) or your local Texas Instruments' sales office.

Because the overall system performance is defined by the quality of the DACs and the associated analog output circuitry, high-quality audio op amps are recommended for the active filters. Texas Instruments' [OPA2134](#), [OPA2353](#), and [NE5532A](#) dual op amps are shown in Figure 38 and Figure 39, and are recommended for use with the PCM1789-Q1.

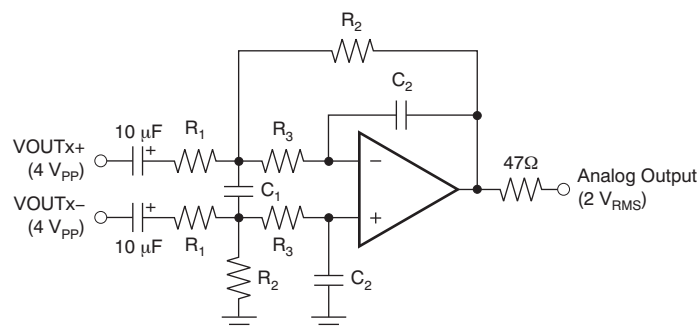

NOTE: Amplifier is an NE5532A x 1/2 or OPA2134 x 1/2; $R_1 = 7.5 \text{ k}\Omega$; $R_2 = 5.6 \text{ k}\Omega$; $R_3 = 360 \Omega$; $C_1 = 3300 \text{ pF}$; $C_2 = 680 \text{ pF}$; Gain = 0.747; $f_{-3 \text{ dB}} = 53 \text{ kHz}$.

Figure 38. AC-Coupled, Post-LPF and Differential to Single-Ended Buffer

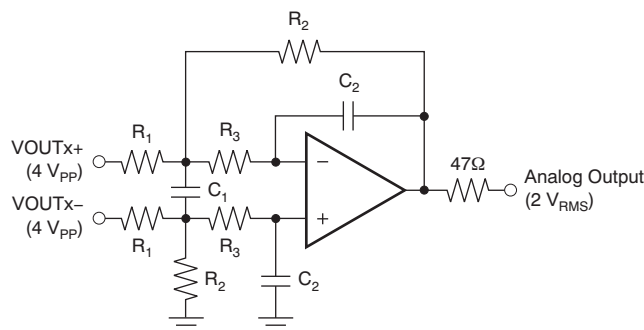

NOTE: Amplifier is an NE5532A x 1/2 or OPA2134 x 1/2; $R_1 = 15 \text{ k}\Omega$; $R_2 = 11 \text{ k}\Omega$; $R_3 = 820 \Omega$; $C_1 = 1500 \text{ pF}$; $C_2 = 330 \text{ pF}$; Gain = 0.733; $f_{-3 \text{ dB}} = 54 \text{ kHz}$.

Figure 39. DC-Coupled, Post-LPF and Differential to Single-Ended Buffer

PCB LAYOUT GUIDELINES

A typical printed circuit board (PCB) layout for the PCM1789-Q1 is shown in Figure 40. A ground plane is recommended, with the analog and digital sections being isolated from one another using a split or cut in the circuit board. The PCM1789-Q1 should be oriented with the digital I/O pins facing the ground plane split/cut to allow for short, direct connections to the digital audio interface and control signals originating from the digital section of the board.

Separate power supplies are recommended for the digital and analog sections of the board. This configuration prevents the switching noise present on the digital supply from contaminating the analog power supply and degrading the dynamic performance of the PCM1789-Q1.

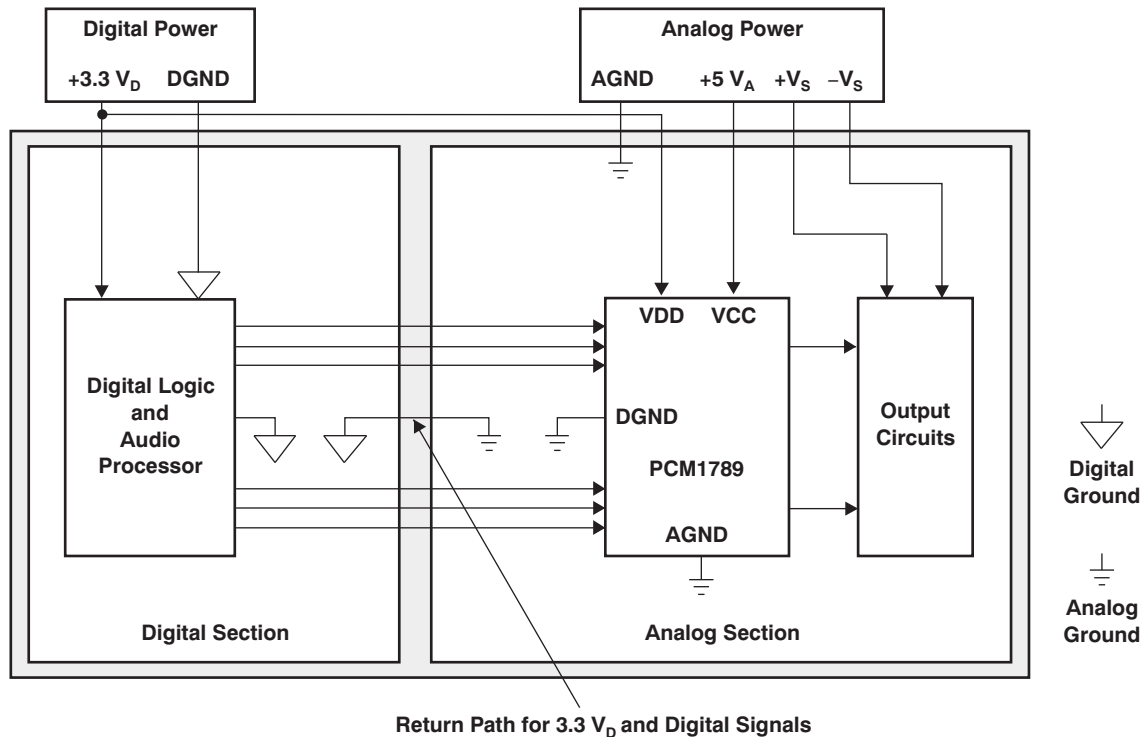

Figure 40. Recommended PCB Layout

重要声明

德州仪器 (TI) 及其下属子公司有权在不事先通知的情况下, 随时对所提供的产品和服务进行更正、修改、增强、改进或其它更改, 并有权随时中止提供任何产品和服务。客户在下订单前应获取最新的相关信息, 并验证这些信息是否完整且是最新的。所有产品的销售都遵循在订单确认时所提供的 TI 销售条款与条件。

TI 保证其所销售的硬件产品的性能符合 TI 标准保修的适用规范。仅在 TI 保修的范围内, 且 TI 认为有必要时才会使用测试或其它质量控制技术。除非政府做出了硬性规定, 否则没有必要对每种产品的所有参数进行测试。

TI 对应用帮助或客户产品设计不承担任何义务。客户应对其使用 TI 组件的产品和应用自行负责。为尽量减小与客户产品和应用相关的风险, 客户应提供充分的设计与操作安全措施。

TI 不对任何 TI 专利权、版权、屏蔽作品权或其它与使用了 TI 产品或服务的组合设备、机器、流程相关的 TI 知识产权中授予的直接或隐含权限作出任何保证或解释。TI 所发布的与第三方产品或服务有关的信息, 不能构成从 TI 获得使用这些产品或服务的许可、授权、或认可。使用此类信息可能需要获得第三方的专利权或其它知识产权方面的许可, 或是 TI 的专利权或其它知识产权方面的许可。

对于 TI 的数据手册或数据表, 仅在没有对内容进行任何篡改且带有相关授权、条件、限制和声明的情况下才允许进行复制。在复制信息的过程中对内容的篡改属于非法的、欺诈性商业行为。TI 对此类篡改过的文件不承担任何责任。

在转售 TI 产品或服务时, 如果存在对产品或服务参数的虚假陈述, 则会失去相关 TI 产品或服务的明示或暗示授权, 且这是非法的、欺诈性商业行为。TI 对此类虚假陈述不承担任何责任。

可访问以下 URL 地址以获取有关其它 TI 产品和应用解决方案的信息:

产品

放大器	http://www.ti.com.cn/amplifiers
数据转换器	http://www.ti.com.cn/dataconverters
DSP	http://www.ti.com.cn/dsp
接口	http://www.ti.com.cn/interface
逻辑	http://www.ti.com.cn/logic
电源管理	http://www.ti.com.cn/power
微控制器	http://www.ti.com.cn/microcontrollers

应用

音频	http://www.ti.com.cn/audio
汽车	http://www.ti.com.cn/automotive
宽带	http://www.ti.com.cn/broadband
数字控制	http://www.ti.com.cn/control
光纤网络	http://www.ti.com.cn/opticalnetwork
安全	http://www.ti.com.cn/security
电话	http://www.ti.com.cn/telecom
视频与成像	http://www.ti.com.cn/video
无线	http://www.ti.com.cn/wireless

邮寄地址: Texas Instruments, Post Office Box 655303, Dallas, Texas 75265
Copyright © 2006, Texas Instruments Incorporated

PACKAGING INFORMATION

Orderable Device	Status (1)	Package Type	Package Drawing	Pins	Package Qty	Eco Plan (2)	Lead finish/ Ball material (6)	MSL Peak Temp (3)	Op Temp (°C)	Device Marking (4/5)	Samples
PCM1789TPWRQ1	ACTIVE	TSSOP	PW	24	2000	RoHS & Green	NIPDAU	Level-3-260C-168 HR	-40 to 105	PCM1789T	Samples

(1) The marketing status values are defined as follows:

ACTIVE: Product device recommended for new designs.

LIFEBUY: TI has announced that the device will be discontinued, and a lifetime-buy period is in effect.

NRND: Not recommended for new designs. Device is in production to support existing customers, but TI does not recommend using this part in a new design.

PREVIEW: Device has been announced but is not in production. Samples may or may not be available.

OBSOLETE: TI has discontinued the production of the device.

(2) **RoHS:** TI defines "RoHS" to mean semiconductor products that are compliant with the current EU RoHS requirements for all 10 RoHS substances, including the requirement that RoHS substance do not exceed 0.1% by weight in homogeneous materials. Where designed to be soldered at high temperatures, "RoHS" products are suitable for use in specified lead-free processes. TI may reference these types of products as "Pb-Free".

RoHS Exempt: TI defines "RoHS Exempt" to mean products that contain lead but are compliant with EU RoHS pursuant to a specific EU RoHS exemption.

Green: TI defines "Green" to mean the content of Chlorine (Cl) and Bromine (Br) based flame retardants meet JS709B low halogen requirements of <=1000ppm threshold. Antimony trioxide based flame retardants must also meet the <=1000ppm threshold requirement.

(3) MSL, Peak Temp. - The Moisture Sensitivity Level rating according to the JEDEC industry standard classifications, and peak solder temperature.

(4) There may be additional marking, which relates to the logo, the lot trace code information, or the environmental category on the device.

(5) Multiple Device Markings will be inside parentheses. Only one Device Marking contained in parentheses and separated by a "-" will appear on a device. If a line is indented then it is a continuation of the previous line and the two combined represent the entire Device Marking for that device.

(6) Lead finish/Ball material - Orderable Devices may have multiple material finish options. Finish options are separated by a vertical ruled line. Lead finish/Ball material values may wrap to two lines if the finish value exceeds the maximum column width.

Important Information and Disclaimer: The information provided on this page represents TI's knowledge and belief as of the date that it is provided. TI bases its knowledge and belief on information provided by third parties, and makes no representation or warranty as to the accuracy of such information. Efforts are underway to better integrate information from third parties. TI has taken and continues to take reasonable steps to provide representative and accurate information but may not have conducted destructive testing or chemical analysis on incoming materials and chemicals. TI and TI suppliers consider certain information to be proprietary, and thus CAS numbers and other limited information may not be available for release.

In no event shall TI's liability arising out of such information exceed the total purchase price of the TI part(s) at issue in this document sold by TI to Customer on an annual basis.

PW0024A

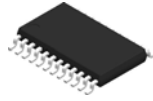

PACKAGE OUTLINE

TSSOP - 1.2 mm max height

SMALL OUTLINE PACKAGE

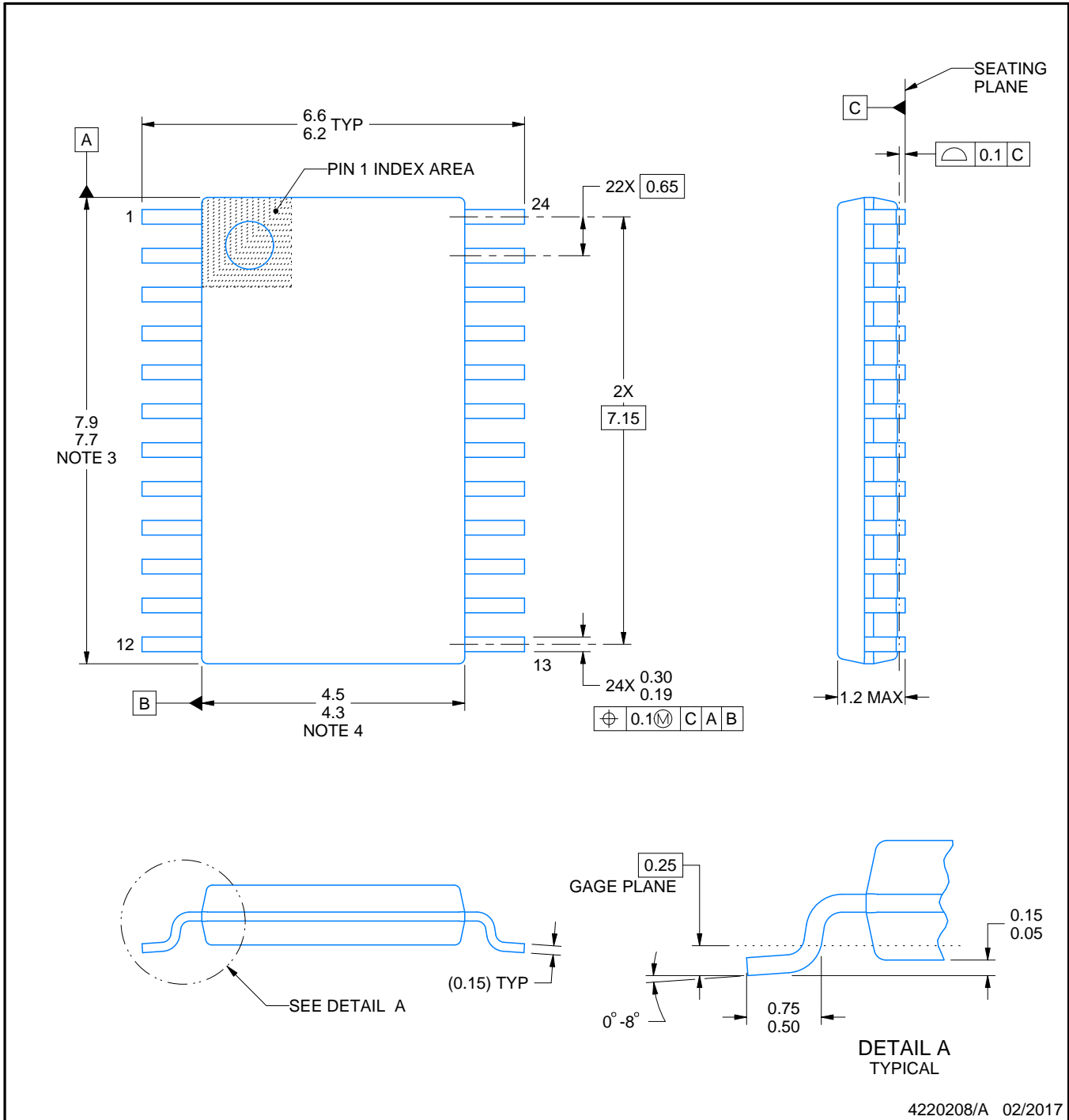

4220208/A 02/2017

NOTES:

1. All linear dimensions are in millimeters. Any dimensions in parenthesis are for reference only. Dimensioning and tolerancing per ASME Y14.5M.
2. This drawing is subject to change without notice.
3. This dimension does not include mold flash, protrusions, or gate burrs. Mold flash, protrusions, or gate burrs shall not exceed 0.15 mm per side.
4. This dimension does not include interlead flash. Interlead flash shall not exceed 0.25 mm per side.
5. Reference JEDEC registration MO-153.

EXAMPLE BOARD LAYOUT

PW0024A

TSSOP - 1.2 mm max height

SMALL OUTLINE PACKAGE

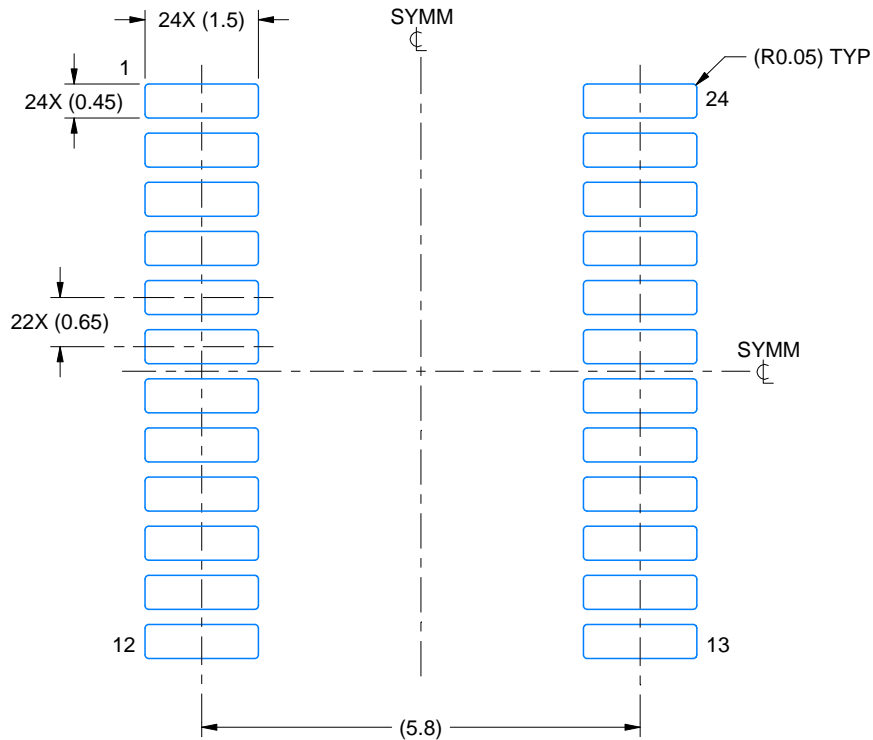

LAND PATTERN EXAMPLE
EXPOSED METAL SHOWN
SCALE: 10X

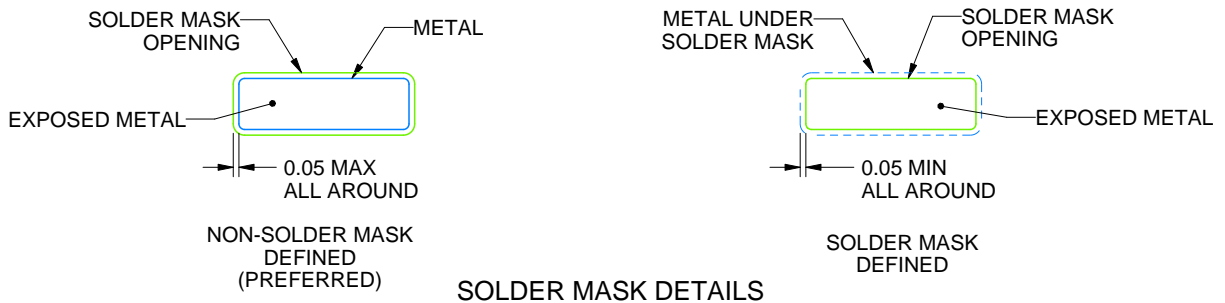

SOLDER MASK DETAILS

4220208/A 02/2017

NOTES: (continued)

- 6. Publication IPC-7351 may have alternate designs.
- 7. Solder mask tolerances between and around signal pads can vary based on board fabrication site.

EXAMPLE STENCIL DESIGN

PW0024A

TSSOP - 1.2 mm max height

SMALL OUTLINE PACKAGE

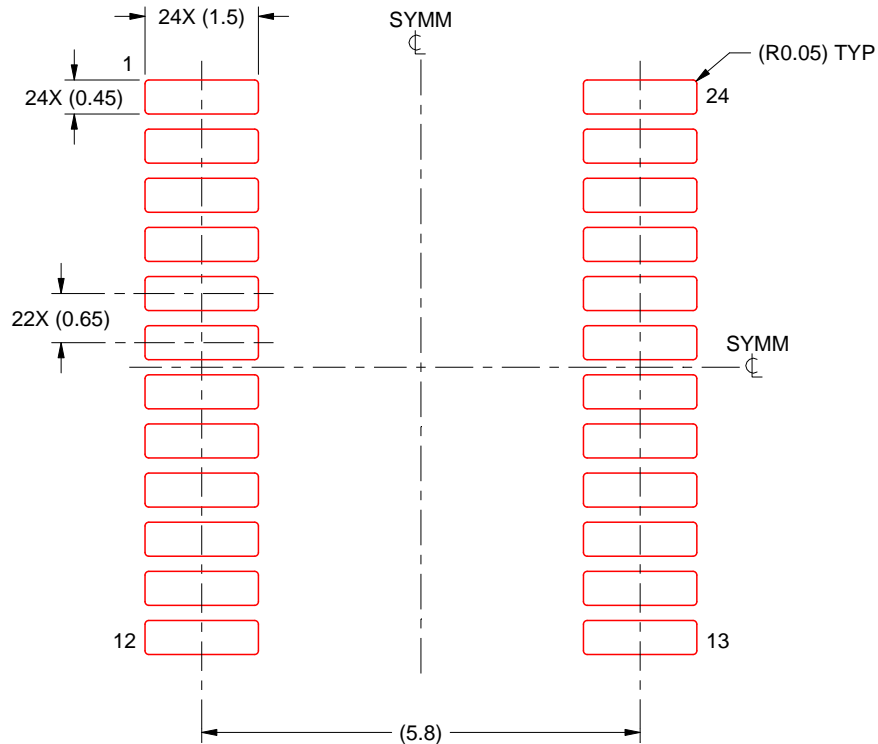

SOLDER PASTE EXAMPLE
BASED ON 0.125 mm THICK STENCIL
SCALE: 10X

4220208/A 02/2017

NOTES: (continued)

8. Laser cutting apertures with trapezoidal walls and rounded corners may offer better paste release. IPC-7525 may have alternate design recommendations.
9. Board assembly site may have different recommendations for stencil design.

重要声明和免责声明

TI 均以“原样”提供技术性及其可靠性数据（包括数据表）、设计资源（包括参考设计）、应用或其他设计建议、网络工具、安全信息和其他资源，不保证其中不含任何瑕疵，且不做任何明示或暗示的担保，包括但不限于对适销性、适合某特定用途或不侵犯任何第三方知识产权的暗示担保。

所述资源可供专业开发人员应用TI 产品进行设计使用。您将对以下行为独自承担全部责任：(1) 针对您的应用选择合适的TI 产品；(2) 设计、验证并测试您的应用；(3) 确保您的应用满足相应标准以及任何其他安全、安保或其他要求。所述资源如有变更，恕不另行通知。TI 对您使用所述资源的授权仅限于开发资源所涉及TI 产品的相关应用。除此之外不得复制或展示所述资源，也不提供其它TI 或任何第三方的知识产权授权许可。如因使用所述资源而产生任何索赔、赔偿、成本、损失及债务等，TI 对此概不负责，并且您须赔偿由此对TI 及其代表造成的损害。

TI 所提供产品均受TI 的销售条款 (<http://www.ti.com.cn/zh-cn/legal/termsofsale.html>) 以及ti.com.cn上或随附TI产品提供的其他可适用条款的约束。TI提供所述资源并不扩展或以其他方式更改TI 针对TI 产品所发布的可适用的担保范围或担保免责声明。

邮寄地址：上海市浦东新区世纪大道 1568 号中建大厦 32 楼，邮政编码：200122

Copyright © 2020 德州仪器半导体技术（上海）有限公司