

SN65HVD62 AISG 开关键控同轴调制解调器收发器

1 特性

- 电源电压范围: 3V 至 5.5V
- 1.6V 至 5.5V 的独立逻辑电源
- 针对接收器的 -15dBm 至 $+5\text{dBm}$ 的宽输入动态范围
- 可在 0dBm 至 $+6\text{dBm}$ 范围内调节驱动器为同轴提供的功率
- 与 AISG 标准兼容的输出发射特性
- 低功耗待机模式
- 针对 RS-485 总线仲裁的方向控制
- 支持高达 115kbps 信令
- 中心频率为 2.176MHz 的集成有源带通滤波器
- 3mm x 3mm 16 引脚四方扁平无引线 (QFN) 封装

2 应用

- AISG - 针对天线线路器件的接口
- 塔顶放大器 (TMA)
- 普通调制解调器 (Modem) 接口

3 说明

这些逻辑电路 (基带) 和一个频率间的收发器调制和解调信号适用于长距离同轴介质。

HVD62 是一款集成 AISG 收发器, 此收发器的被设计成与天线接口标准组 v2.0 规范兼容。

HVD62 接收器集成了一个有源带通滤波器, 这样即使在寄生频率组件出现的时候仍然能够解调信号。此滤波器有一个 2.176MHz 的中心频率。

发射器支持介于 $+0\text{dBm}$ 和 $+6\text{dBm}$ 之间的可调输出功率提供给 50Ω 同轴电缆。HVD62 发射器与 AISG 标准规定的对发射频谱的要求兼容。

提供一个方向控制输出以使得针对一个 RS-485 接口的总线仲裁更加便捷。这些器件为晶振集成了一个振荡器, 并且接受到振荡器的标准时钟输入。

器件信息⁽¹⁾

器件型号	封装	封装尺寸 (标称值)
SN65HVD62	VQFN (16)	3.00mm x 3.00mm

(1) 要了解所有可用封装, 请见数据表末尾的可订购产品附录。

4 方框图

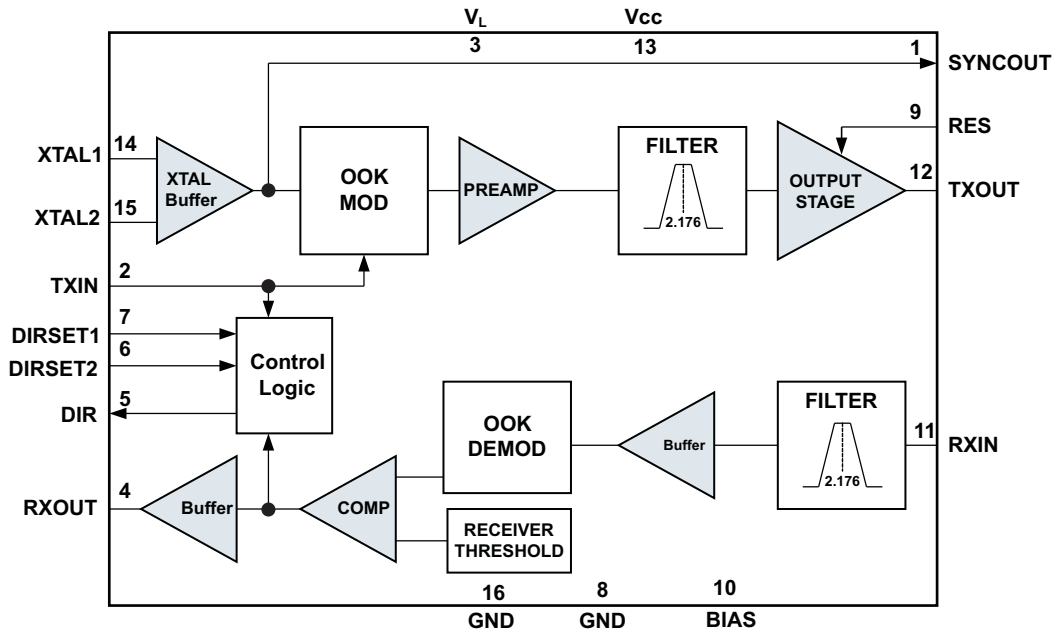

目录

1	特性	1	8	Parameter Measurement Information	11
2	应用	1	9	Detailed Description	14
3	说明	1	9.1	Overview	14
4	方框图	1	9.2	Functional Block Diagram	14
5	修订历史记录	2	9.3	Device Functional Modes.....	14
6	Pin Configuration and Functions	3	10	Application and Implementation.....	16
7	Specifications.....	4	10.1	Application Information.....	16
7.1	Absolute Maximum Ratings	4	11	器件和文档支持	18
7.2	ESD Ratings.....	4	11.1	文档支持	18
7.3	Thermal Information	4	11.2	商标	18
7.4	Recommended Operating Conditions.....	5	11.3	静电放电警告.....	18
7.5	Electrical Characteristics.....	6	11.4	术语表	18
7.6	Switching Characteristics	7	12	机械、封装和可订购信息.....	18
7.7	Typical Characteristics	8			

5 修订历史记录

NOTE: Page numbers for previous revisions may differ from page numbers in the current version.

Changes from Revision B (January 2013) to Revision C	Page
• 已添加器件信息表, ESD 额定值表, 器件功能模式, 应用和实施部分, 器件和文档支持部分以及机械、封装和可订购信息部分。	1
• Moved the Storage temperature From: <i>Thermal Information</i> To: <i>Absolute Maximum Ratings</i> ⁽¹⁾	4
• Changed T _A in the <i>Recommended Operating Conditions</i> From: MAX = 85°C To: MAX = 105°C.....	5

Changes from Revision A (January 2012) to Revision B	Page
• 已将特性“可在 +3dBm 至 +6dBm 范围内调节驱动器为同轴提供的功率”更改为“可在 0dBm 至 +6dBm 范围内调节驱动器为同轴提供的功率”	1
• Added Storage temperature to the <i>Thermal Information</i>	4
• Change the MIN value of V _{RES} in the ROC table From: 0.84 To: 0.7 V	5
• Change the TYP value of C _C in the ROC table From: 270 To: 220 nF.....	5
• Changed the <i>Electrical Characteristics</i>	6
• Changed the <i>Switching Characteristics</i>	7
• Added the <i>Typical Characteristics</i> section.....	8
• Changed the <i>Parameter Measurement Information</i> section.....	11
• Changed the <i>Application Information</i> section.....	16

Changes from Original (September 2011) to Revision A	Page
• Changed Pin 4 label (lower right) in the <i>Pin Configuration and Functions</i> diagram from TXIN to RXOUT	3
• Changed the <i>Pin Functions</i> table by merging the DESCRIPTION cells for pins 5, 6, and 7 and deleted the word DIRSET from the beginning of the second line in that description field.	3
• 已添加 rows 162 and 163 to the <i>Electrical Characteristics</i> table, under RECEIVER FILTER section.....	6
• 已添加 rows 210 and 211 to the <i>Switching Characteristics</i> table.....	7
• 已添加 表 1 and 表 2	15
• 已添加 图 22 State Transition Diagram	15

6 Pin Configuration and Functions

**RGT (VQFN) Package
16 Pins
Top View**

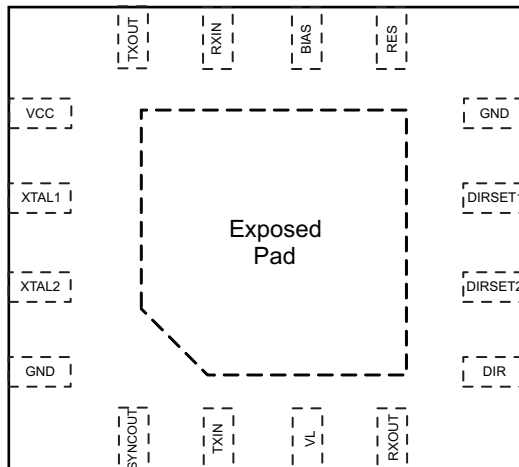

Pin Functions

PIN	HVD62 PIN	DESCRIPTION
	NAME	
1	SYNCOUT	Open drain output to synchronize other devices to the 4x-carrier oscillator at XTAL1,2. (8.704 MHz for HVD62)
2	TXIN	Digital data bit stream to driver.
3	VL	Logic supply voltage for the device.
4	RXOUT	Digital data bit stream from receiver.
5	DIR	DIR: Direction control output signal for bus arbitration.
6	DIRSET2	DIRSET1 and DIRSET2: Bits to set the duration of DIR DIRSET[2,1]:[L,L]=9.6kbps [L,H]=38.4kbps [H,L]=115kbps [H,H]=Standby Mode
7	DIRSET1	
8	GND	Ground
9	RES	Input voltage to adjust driver output power. Set by external resistors from BIAS pin to GND.
10	BIAS	Bias voltage output for setting driver output power by external resistors.
11	RXIN	Modulated input signal to the receiver.
12	TXOUT	Modulated output signal from the driver.
13	VCC	Analog supply voltage for the device.
14	XTAL1	Crystal oscillator's IO pins. Connect a $4 \times f_C$ crystal between these pins. Or connect XTAL1 to an 8.704 MHz clock and connect XTAL2 to GND.
15	XTAL2	
16	GND	Ground
-	EP	Exposed pad. Recommended to be connected to ground plane for best thermal conduction.

7 Specifications

7.1 Absolute Maximum Ratings⁽¹⁾

	VALUES		UNIT
	MIN	MAX	
Supply voltage, V_{CC} and V_L	-0.5	6	V
Voltage range at coax pins	-0.5	6	V
Voltage range at logic pins	-0.3	$V_L + 0.3$	V
Logic Output Current	-20	20	mA
TXOUT output current	Internally limited		
SYNCOUT output current	Internally limited		
Junction Temperature, T_J		170	°C
Storage temperature, T_{STG}	-65	150	
Continuous total power dissipation	See the Thermal Information		°C

- (1) Stresses beyond those listed under “absolute maximum ratings” may cause permanent damage to the device. These are stress ratings only and functional operation of the device at these or any other conditions beyond those indicated under “recommended operating conditions” is not implied. Exposure to absolute-maximum-rated conditions for extended periods may affect device reliability.

7.2 ESD Ratings

		VALUE	UNIT
$V_{(ESD)}$	Electrostatic discharge	Human-body model (HBM), per ANSI/ESDA/JEDEC JS-001 ⁽¹⁾	±2000 V

- (1) JEDEC document JEP155 states that 500-V HBM allows safe manufacturing with a standard ESD control process.

7.3 Thermal Information

THERMAL METRIC ⁽¹⁾		SN65HVD62	UNIT
		RGT (VQFN)	
		(16) PINS	
$R_{\theta JA}$	Junction-to-ambient thermal resistance	49.4	°C/W
$R_{\theta Jctop}$	Junction-to-case (top) thermal resistance	64.2	
$R_{\theta JB}$	Junction-to-board thermal resistance	22.9	
Ψ_{JT}	Junction-to-top characterization parameter	1.7	
Ψ_{JB}	Junction-to-board characterization parameter	22.9	
$R_{\theta Jcbot}$	Junction-to-case (bottom) thermal resistance	25.0	

- (1) For more information about traditional and new thermal metrics, see the *IC Package Thermal Metrics* application report, [SPRA953](#).

7.4 Recommended Operating Conditions

		MIN	NOM	MAX	UNIT
V_{CC}	Analog supply voltage	3		5.5	V
V_L	Logic supply voltage	1.6		5.5	V
$V_{I(pp)}$	Input signal amplitude at RXIN			1.12	V _{pp}
V_{IH}	High-level input voltage	TXIN, DIRSET1, DIRSET2		$70\%V_L$	V
		XTAL1, XTAL2		$70\%V_{CC}$	V
V_{IL}	Low-level input voltage	TXIN, DIRSET1, DIRSET2		$30\%V_L$	V
		XTAL1, XTAL2		$30\%V_{CC}$	V
$1/t_{UI}$	Data signaling rate	9.6		115	kbps
F_{OSC}	Oscillator frequency		HVD62		MHz
T_A	Operating free-air temperature	–40		105	°C
T_J	Junction Temperature	–40		125	°C
R_{LOAD}	Load impedance between TXOUT to RXIN		50		Ω
	Load impedance between RXIN and GND at f_C (channel)		50		
R1	Bias resistor between BIAS and RES		4.1		kΩ
R2	Bias resistor between RES and GND		10		kΩ
R_{SYNC}	Pull-up resistor between SYNCOUT and V_{CC}		1		kΩ
V_{RES}	Voltage at RES pin	0.7		1.5	V
C_C	Coupling capacitance between RXIN and Coax (channel)		220		nF
C_{BIAS}	Capacitance between BIAS and GND		1		μF

7.5 Electrical Characteristics

over recommended operating conditions (unless otherwise noted)

	PARAMETER		TEST CONDITIONS	MIN	TYP	MAX	UNIT
POWER SUPPLY							
100	I_{CC}	Supply current (V_{CC})	TXIN = L (Active)	DIRSET1 = L DIRSET2 = H	28	33	mA
101			TXIN = H (Quiescent)		25	31	
102			TXIN = 115 kbps, 50% duty cycle	27	33		
99			(Standby) DIRSET1 = DIRSET2=H	12	17		
103	I_L	Logic supply current	TXIN = H, RXIN = DC input			50	μ A
104	$\frac{\Delta V_{RXIN}}{\Delta V_{CC}}$	Receiver power supply rejection ratio	$V_{TXIN} = V_L$	45	60		dB
LOGIC PINS							
112	V_{OH}	High-level logic output voltage (RXOUT, DIR)	$I_{OH} = -4$ mA for $V_L > 2.4$ V, $I_{OH} = -2$ mA for $V_L < 2.4$ V	90% V_L			V
113	V_{OL}	Low-level logic output voltage (RXOUT, DIR)	$I_{OL} = 4$ mA for $V_L > 2.4$ V, $I_{OL} = 2$ mA for $V_L < 2.4$ V		10% V_L		V
114	I_{IH}/I_{IL}	Logic input current (DIRSET1/2)		-1		10	μ A
	I_{IH}/I_{IL}	Logic input current (TXIN)		-2		1	μ A
COAX DRIVER							
130	V_{OPP}	Peak-to-peak output voltage at device pin TXOUT (See Figure 19)	$V_{RES} = 1.5$ V (Maximum setting)	2.24	2.5		V_{PP}
132			$V_{RES} = 0.7$ V (Minimum setting)		1.17	1.3	
130A	V_{OPP}	Peak-to-peak voltage at coax out (See Figure 19)	$V_{RES} = 1.5$ V	5	6		dBm
132A			$V_{RES} = 0.7$ V		-0.6	0.3	
134	V_{OZ}	Off-state output voltage	At TXOUT			1	mVpp
134A			At coax out			-60	dBm
136		Output emissions	Coupled to coaxial cable with characteristic impedance 50 Ohms, as shown in Figure 1. With a recommended 470 pF capacitor between RXIN and GND. Measurements above 150 MHz are determined by setup.	Conforms to AISG spectrum emissions mask, 3GPP TS 25.461, see Figure 21			
41	f_o	Output frequency (HVD62)			2.176		MHz
142	Δf	Output frequency variation		-100		100	ppm
143	Z_o	Output impedance	At 100 kHz		0.03		Ω
144			At 10 MHz		3.5		Ω
145	$ I_{OS} $	Short-circuit output current	TXOUT is also protected by a thermal shutdown circuit during short-circuit faults		300	450	mA
COAX RECEIVER							
152	V_{IT}	Input threshold	$f_{IN} = 2.176$ MHz	79	112	158	mVPP
152A				-18	-15	-12	dBm
154	Z_{IN}	Input impedance	$f = f_o$	11	21		k Ω
RECEIVER FILTER							
160	f_{PB}	Passband	$VRXIN = 1.12VP_P$	1.1		4.17	MHz
161	f_{REJ}	Receiver rejection range	2.176MHz carrier amplitude of 112.4 mV _{PP} , Frequency band of spurious components with 800 mVPP allowed.	1.1		4.17	MHz
162	$t_{noise\ filter}$	Receiver noise filter time (slow bit rate)	DIRSET for 9.6kbps		4		μ s
163		Receiver noise filter time (fast bit rate)	DIRSET for > 9.6 kbps		2		
XTAL AND SYNC							
171	I_i	Input leakage current	XTAL1, XTAL2, 0V < $V_{IN} < V_{CC}$	-15		15	μ A
172	V_{OL}	Output low voltage	SYNCOUT, with 1 k Ω resistor from SYNCOUT to V_{CC}			0.4	V

7.6 Switching Characteristics

over recommended operating conditions (unless otherwise noted)

		PARAMETER	TEST CONDITIONS	MIN	TYP	MAX	UNIT
201	t_{pAQ}, t_{pQA}	Coax driver propagation delay	See 图 19			5	μ s
202	t_r, t_f	Coax receiver output rise/fall time	$C_L = 15$ pF, $R_L = 1$ k Ω , See 图 19			20	ns
203	t_{PHL}, t_{PLH}	Receiver propagation delay	See 图 20		5.5	11	μ s
204	Duty Cycle	Coax receiver output duty cycle	$V_{RXIN(ON)} = 630$ mVpp, $V_{RXIN(OFF)} < 5$ mVpp, 50% duty cycle	40%		60%	
214			$V_{RXIN(ON)} = 200$ mVpp, $V_{RXIN(OFF)} < 5$ mVpp, 50% duty cycle	40%		60%	
206	t_{DIR}	Direction control active duration	DIRSET2 = DIRSET1 = GND or OPEN		1667		μ s
207			DIRSET2 = GND, DIRSET1 = VL		417		
208			DIRSET2 = VL, DIRSET1 = VL		137		
209	$t_{DIR\ Skew}$	Direction control skew (DIR to RXOUT)		270			ns
210	t_{DIS}	Standby disable delay	300 mVpp at 2.176 MHz on RXIN		2		ms
211	t_{EN}	Standby enable delay			2		

7.7 Typical Characteristics

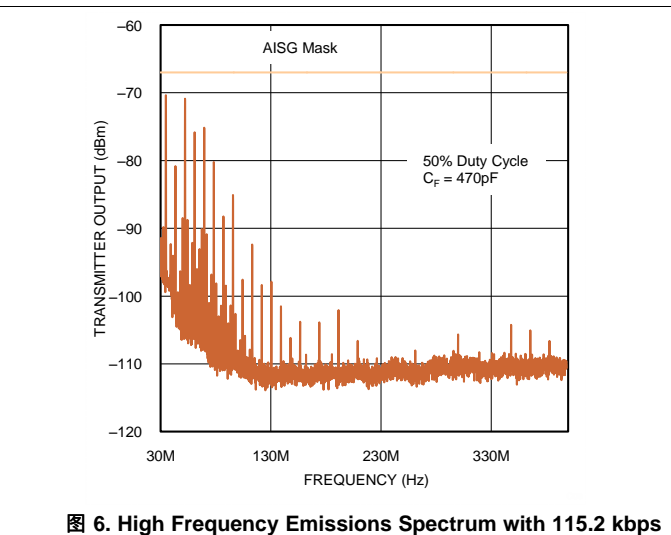
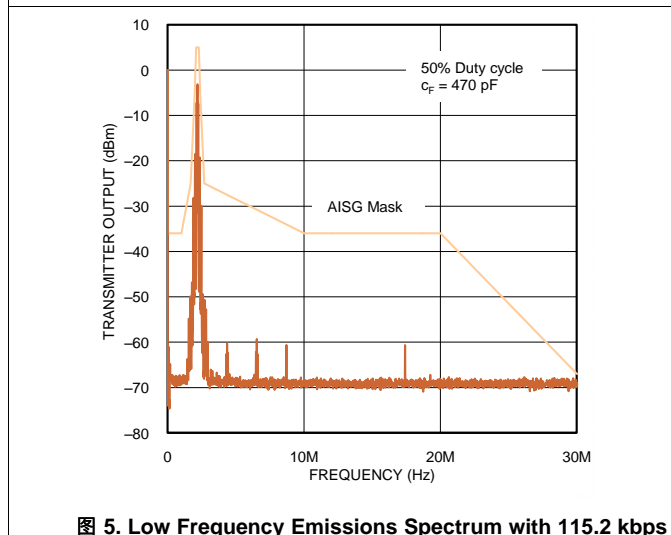
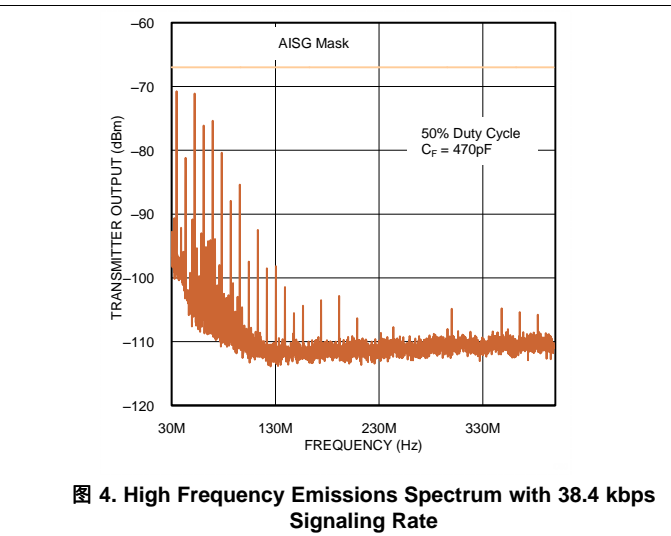
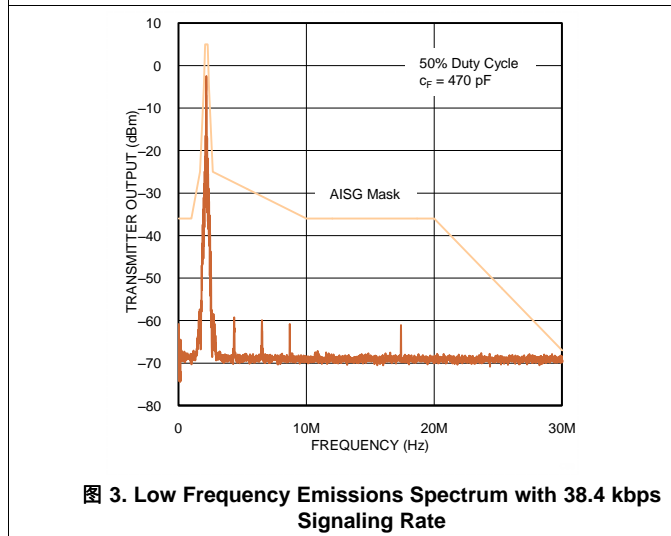
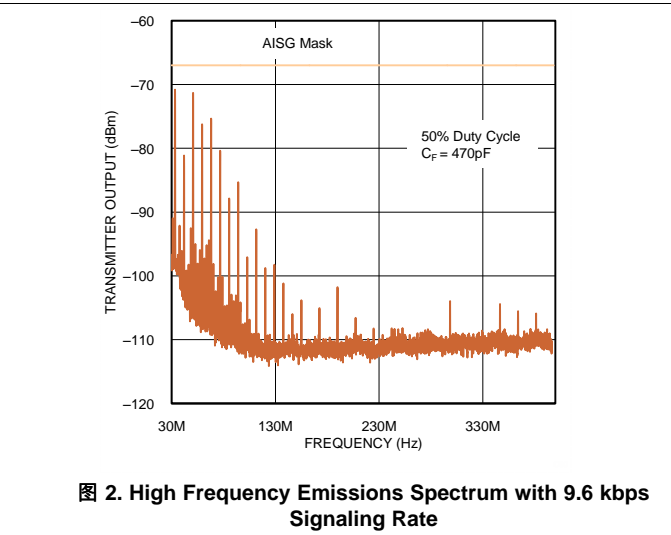
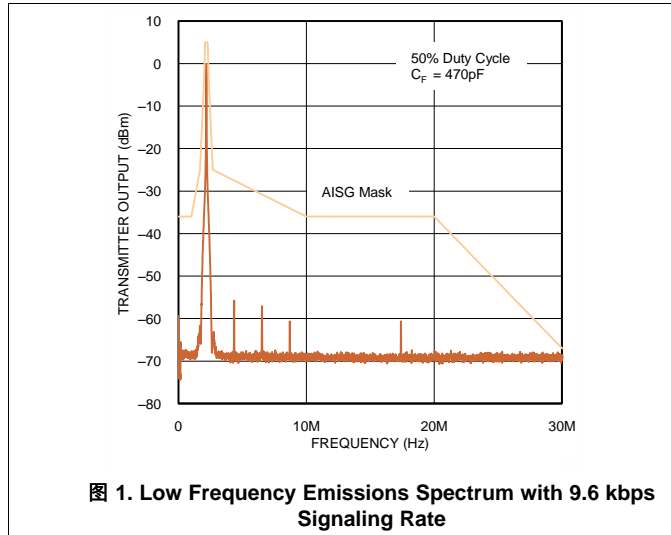

Typical Characteristics (接下页)



图 7. Transmitter Output Impedance



图 8. Transmit Power Adjustment

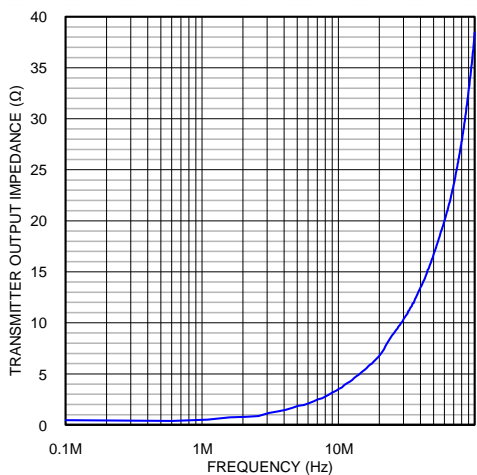

图 9. Supply Current versus Supply Voltage while Transmitting

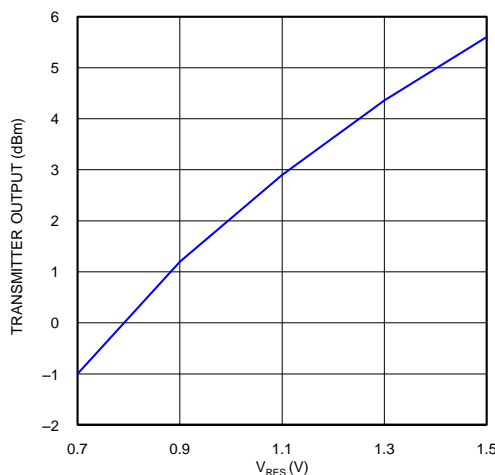

图 10. Supply Current versus Supply Voltage in Standby Mode

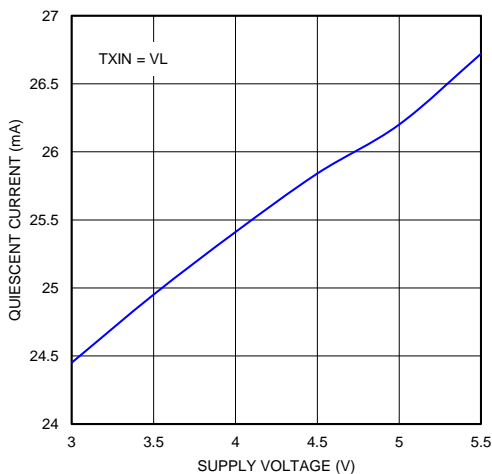

图 11. Supply Current versus Temperature in Standby Mode

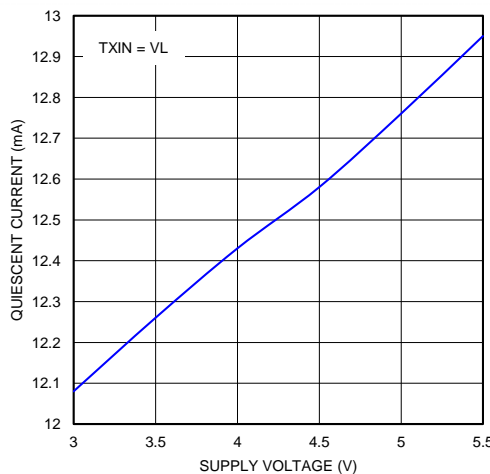

图 12. Transmitter Output Power versus Supply Voltage

Typical Characteristics (接下页)

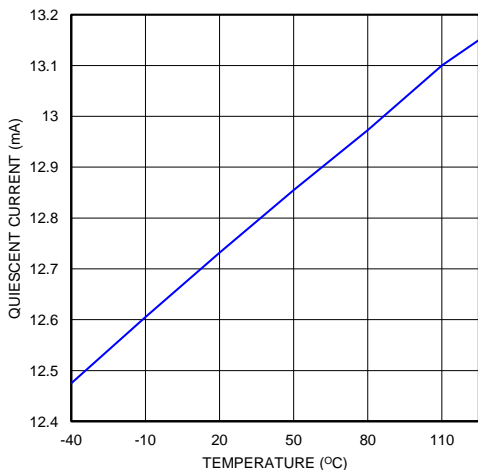

图 13. Transmitter Output Power versus Temperature

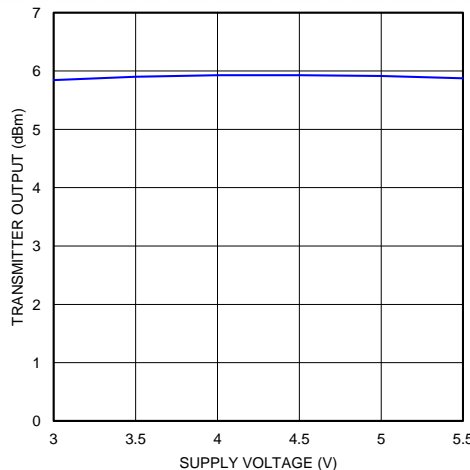

图 14. Receiver Input Impedance versus Frequency

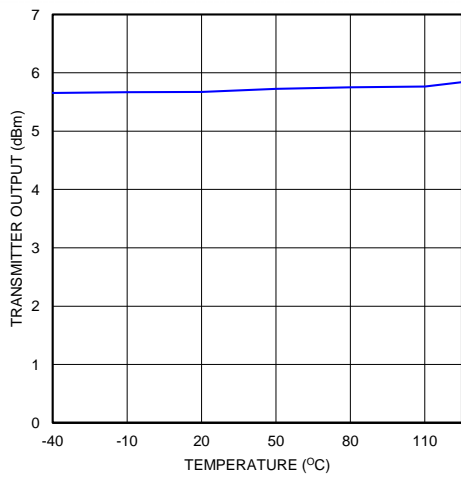

图 15. Receiver Input Threshold versus Temperature

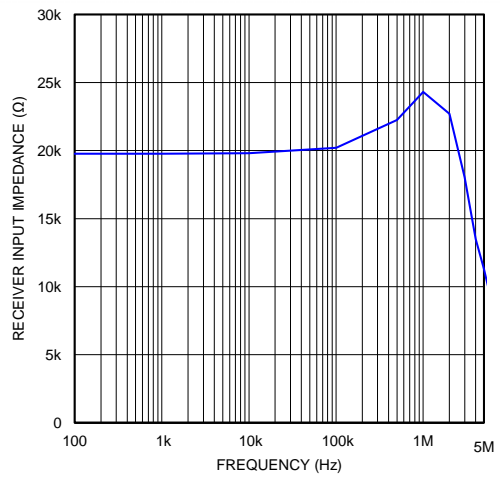

图 16. DIR Output Delay versus Temperature

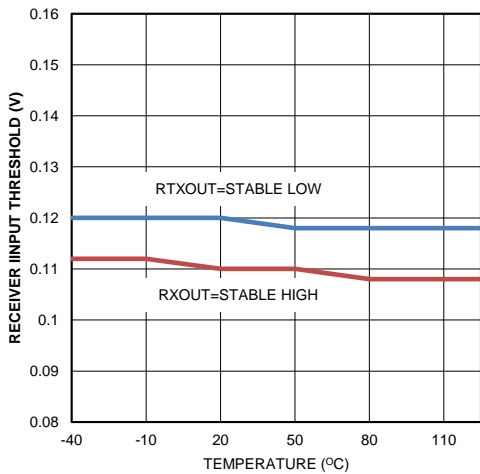

图 17. Receiver Duty Cycle with 9.6 kbps Signaling Rate

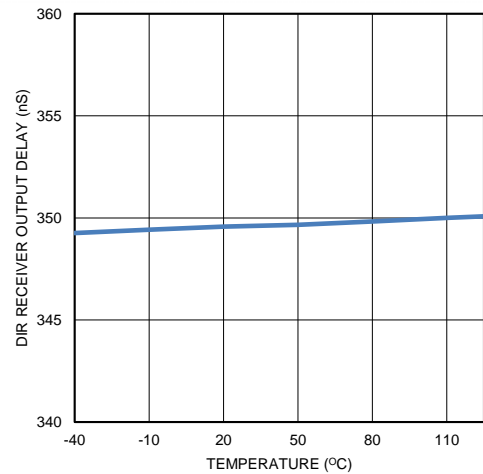

图 18. Receiver Duty Cycle with 115.2 kbps Signaling Rate

8 Parameter Measurement Information

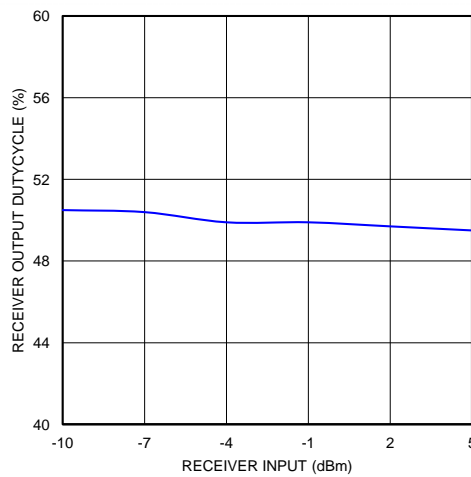
Signal generator rate is 115 kbps, 50% duty cycle, rise and fall times less than 6 nsec, nominal output levels 0V and 3V. Coupling capacitor C_c is 220 nF.

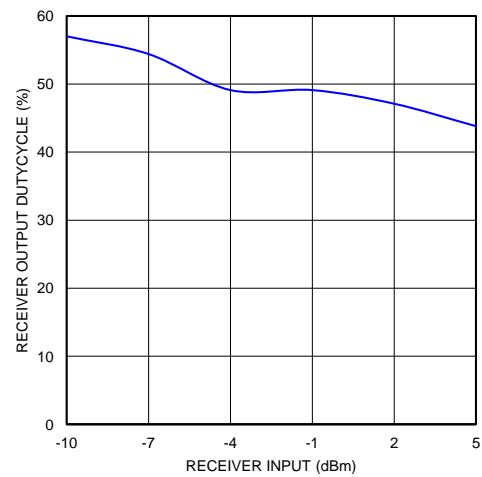

图 19. Measurement of Modem Driver Output Voltage With 50 Ω Loads

Parameter Measurement Information (接下页)

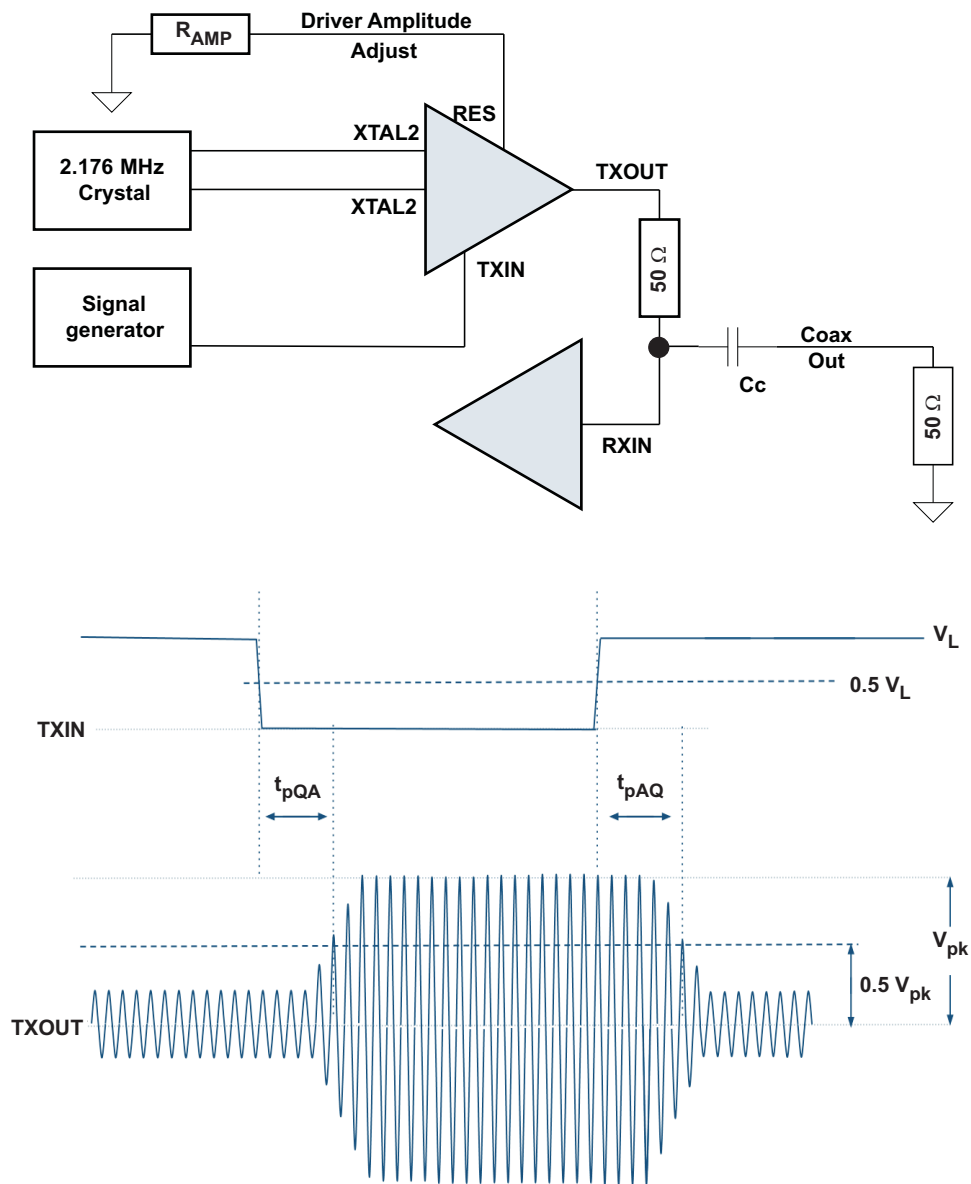

图 20. Measurement of Modem Receiver Propagation Delays

Parameter Measurement Information (接下页)

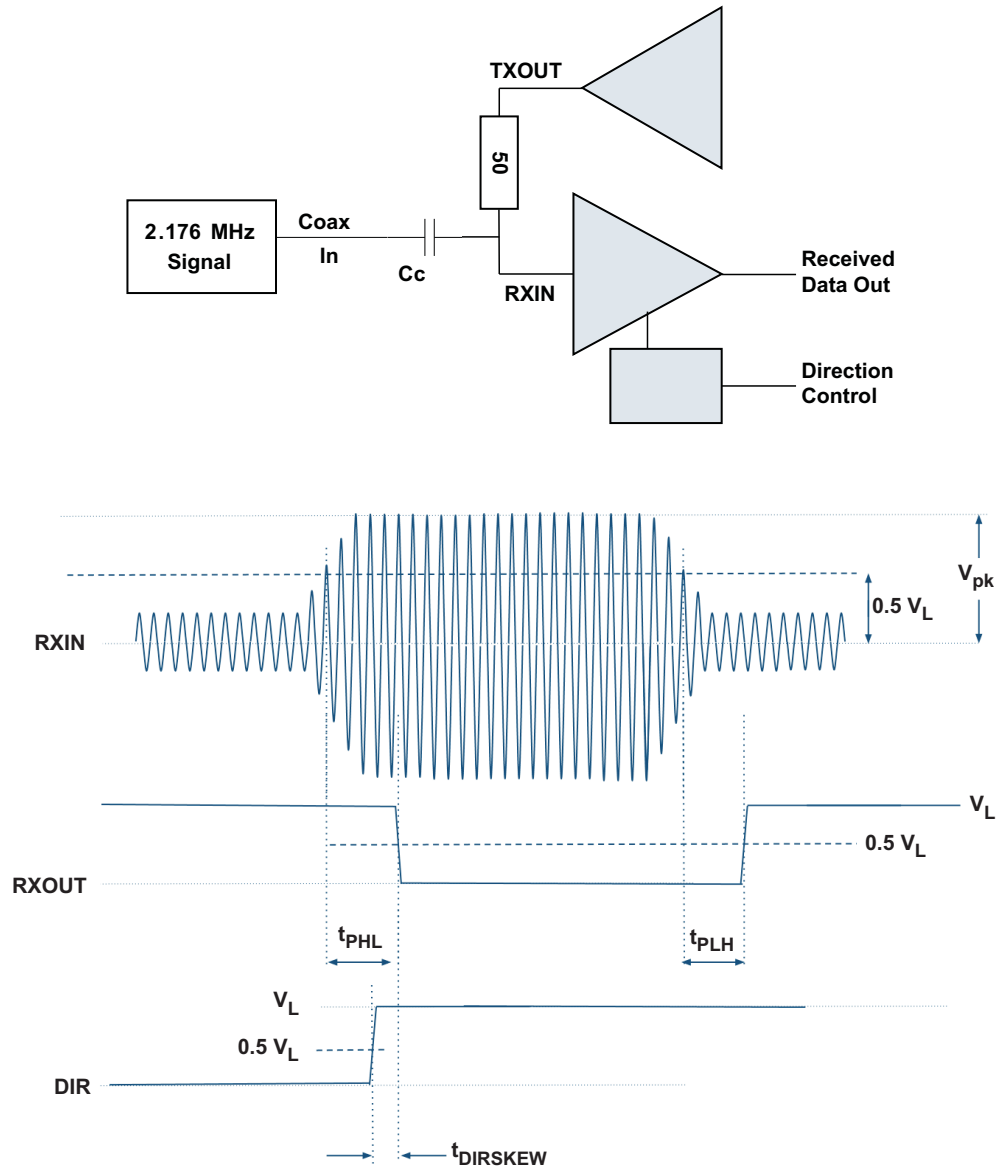

图 21. AISG Emissions Template

9 Detailed Description

9.1 Overview

If DIRSET1 and DIRSET2 are in a logic High state, the device will be in STANDBY mode. While in STANDBY mode, the Receiver functions normally, detecting carrier frequency activity on the RXIN pin and setting the RXOUT state as discussed below. But the Transmitter circuits are not active in STANDBY, thus the TXOUT pin is idle regardless of the logic state of TXIN. The supply current in STANDBY mode is significantly reduced, allowing power savings when the node is not transmitting.

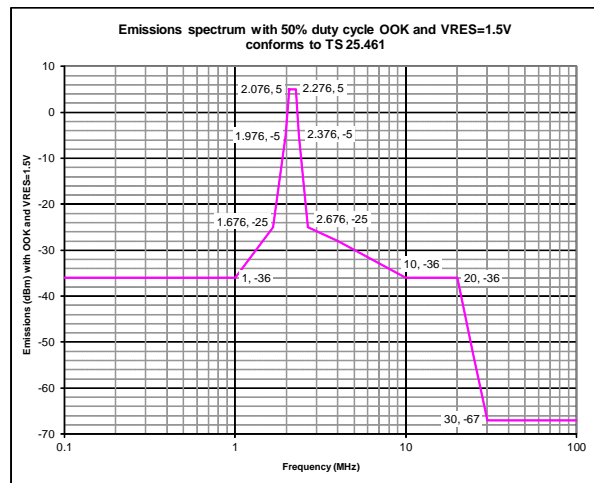
9.2 Functional Block Diagram

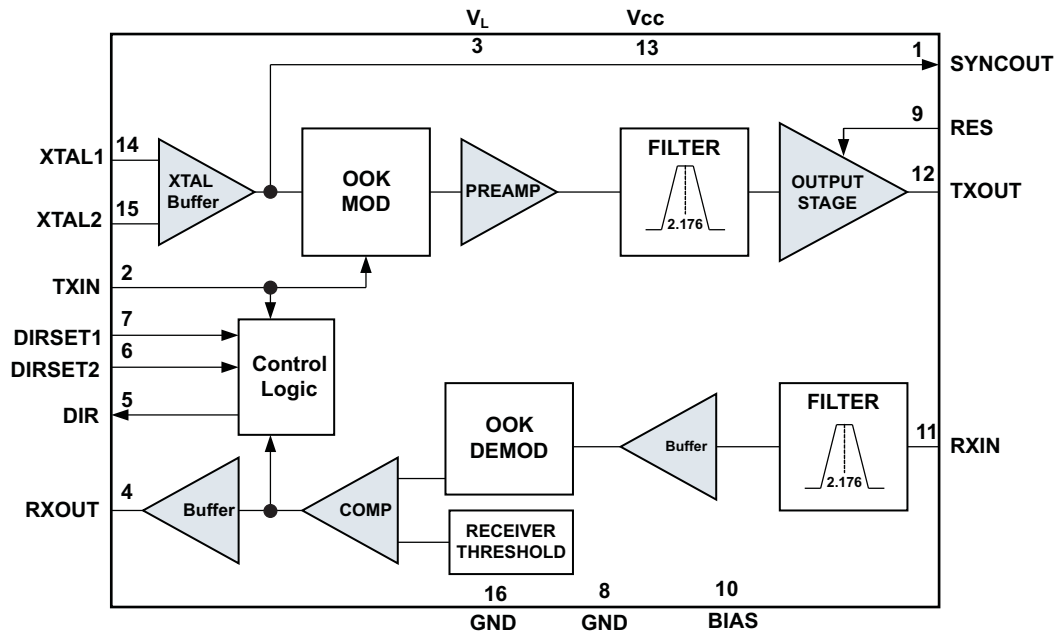

9.3 Device Functional Modes

When not in STANDBY mode, the default power-on state is IDLE. When in IDLE mode, RXOUT is High, and TXOUT is quiet. The device transitions to RECEIVE mode when a valid modulated signal is detected on the RXIN line <OR> the device transitions to TRANSMIT mode when TXIN goes Low. The device stays in either RECEIVE or TRANSMIT mode until DIR Timeout (nominal 16 bit times) after the last activity on RXOUT or TXIN.

When in RECEIVE mode:

- RXOUT responds to all valid modulated signals on RXIN, whether from the local transmitter, a remote transmitter, or long noise burst.
- TXOUT responds to TXIN, generating 2.176 MHz signals on TXOUT when TXIN is Low, and TXOUT is quiet when TXIN is High. (In normal operation, TXIN is expected to remain High when the device is in RECEIVE mode).
- The device stays in RECEIVE mode until 16 bit times after the last rising edge on RXOUT, caused by valid modulated signal on the RXIN line.

When in TRANSMIT mode:

- RXOUT stays High, regardless of the input signal on RXIN.
- TXOUT responds to TXIN, generating 2.176 MHz signals on TXOUT when TXIN is Low, and TXOUT is quiet when TXIN is High.
- The device stays in TRANSMIT mode until 16 bit times after TXIN goes High.

Device Functional Modes (接下页)

表 1. Driver Function Table⁽¹⁾

TXIN	[DIRSET1, DIRSET2]	TXOUT	COMMENT
H	[L,L], [L,H] or [H,L]	< 1 mV _{pp} at 2.176 MHz	Driver not active
L		V _{OPP} at 2.176 MHz	Driver active
X	[H,H]	< 1 mV _{pp} at 2.176 MHz	Standby mode

(1) H = High, L = Low, X = Indeterminate

表 2. Receiver and DIR Function Table⁽¹⁾

RXIN	RXOUT	DIR	COMMENT (see 图 22)
IDLE mode (not transmitting or receiving)			
< V _{IT} at 2.176 MHz for longer than DIR timeout	H	L	No outgoing or incoming signal
RECEIVE mode (not already transmitting)			
< V _{IT} at 2.176 MHz for less than t _{DIR} Timeout	H	H	Incoming '1' bit, DIR stays HIGH for DIR Timeout
> V _{IT} at 2.176 MHz for longer than t _{noise filter}	L	H	Incoming '0' bit, DIR output is HIGH
TRANSMIT mode (not already receiving)			
X	H	L	Outgoing message, DIR stays LOW for DIR Timeout

(1) H = High, L = Low



图 22. State Transition Diagram

10 Application and Implementation

注

Information in the following applications sections is not part of the TI component specification, and TI does not warrant its accuracy or completeness. TI's customers are responsible for determining suitability of components for their purposes. Customers should validate and test their design implementation to confirm system functionality.

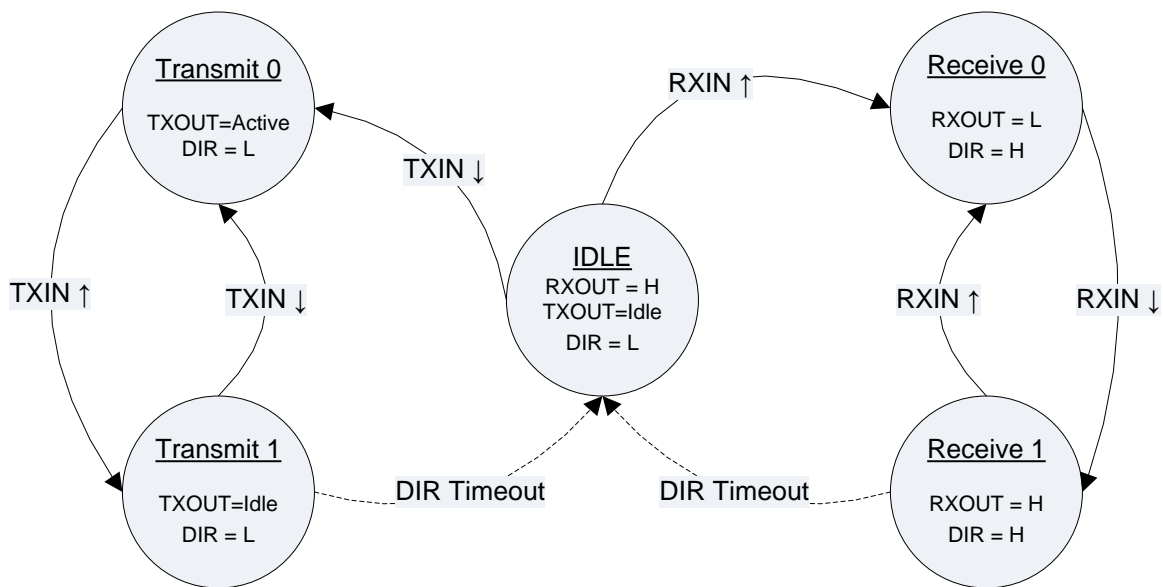
10.1 Application Information

10.1.1 Driver Amplitude Adjust

The SN65HVD62 can provide up to 2.5 V peak-to-peak of output signal at the TXOUT pin to compensate for potential loss within the external filter, cable, connections, and termination. External resistors are used to set the amplitude of the modulated driver output signal. Resistors connected across RES and BIAS set the output amplitude. The maximum peak-to-peak voltage at TXOUT is 2.5 V, corresponding to +6 dBm on the coaxial cable. The TXOUT voltage level can be adjusted by choice of resistors to set the voltage at the RES pin, according to the following equation:

$$V_{TXOUT} (V_{P-P}) = (2.5 V_{P-P} \times V_{RES} (V)) / 1.5 V \quad V_{RES} (V) = 1.5 V \times R2 / (R1 + R2) \quad V_{TXOUT} (V_{P-P}) = 2.5 V_{P-P} \times R2 / (R1 + R2). \quad (1)$$

The voltage at the RES pin should be between 0.7 V and 1.5 V. Connect RES directly to the BIAS ($R1 = 0 \Omega$) for maximum output level of 2.5 V peak-to-peak. This gives a minimum voltage level at TXOUT of 1.2 V peak-to-peak, corresponding to about 0 dBm at the coaxial cable. A 1 μ F capacitor should be connected between the BIAS pin and GND. To obtain a nominal power level of +3 dBm at the feeder cable as the AISG standard requires, use $R1 = 4.1k \Omega$ and $R2 = 10k \Omega$ that provide 1.78 V_{P-P} at TXOUT.

10.1.2 Direction Control

In many applications the mast-top modem which receives data from the base will then distribute the received data through an RS-485 network to several mast-top devices. When the mast-top modem receives the first logic 0 bit (active modulated signal) it will take control of the mast-top RS-485 network by asserting the Direction Control signal. The duration of the Direction Control assertion should be optimized to pass a complete message of length B bits at the known signaling rate ($1/t_{BIT}$) before relinquishing control of the mast-top RS-485 network. For example, if the messages are 10 bits in length ($B=10$) and the signaling rate is 9600 bits per second ($t_{BIT} = 0.104$ msec) then a positive pulse of duration 1.7 msec is sufficient (with margin to allow for network propagation delays) to enable the mast-top RS-485 drivers to distribute each received message.

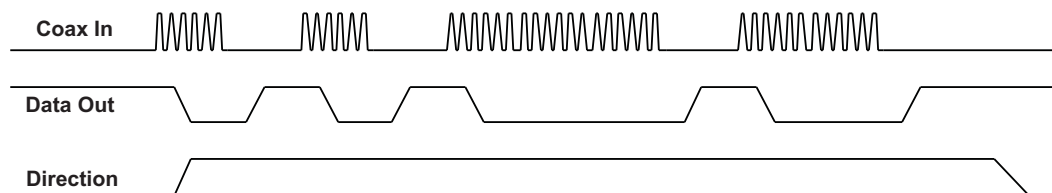

10.1.3 Direction Control Time Constant

The time constant for the Direction Control function can be set by the Control Mode pins, DIRSET1/DIRSET2. These pins should be set to correspond to the desired data rate. With no external connections to the Control Mode pins, the internal time constant is set to the maximum value, corresponding to the minimum data rate.

Application Information (接下页)

10.1.4 Conversion Between dBm and Peak-to-peak Voltage

$$\text{dBm} = 20 \times \text{LOG}_{10} [\text{Volts-pp} / \text{SQRT}(0.008 \times Z_o)] = 20 \times \text{LOG}_{10} [\text{Volts-pp} / 0.63] \text{ for } Z_o = 50 \Omega \quad (2)$$

$$\text{Volts-pp} = \text{SQRT}(0.008 \times Z_o) \times 10^{(\text{dBm}/20)} = 0.63 \times 10^{(\text{dBm}/20)} \text{ for } Z_o = 50 \Omega \quad (3)$$

The following table shows conversions between dBm and peak-to-peak voltage with 50 Ω load, for various levels of interest including reference levels from the 3GPP TS 25.461 Technical Specification.

SIGNAL ON COAX (luant Layer 1)	dBm	Vpp (V)
Maximum Driver ON Signal	5	1.12
Nominal Driver ON Signal	3	0.89
Minimum Driver ON Signal	1	0.71
AISG Maximum Receiver Threshold	-12	0.16
Nominal Receiver Threshold	-15	0.11
Minimum Receiver Threshold	-18	0.08
Maximum Driver OFF Signal	-40	0.006

11 器件和文档支持

11.1 文档支持

11.2 商标

All trademarks are the property of their respective owners.

11.3 静电放电警告



这些装置包含有限的内置 ESD 保护。存储或装卸时，应将导线一起截短或将装置放置于导电泡棉中，以防止 MOS 门极遭受静电损伤。

11.4 术语表

[SLYZ022](#) — *TI* 术语表。

这份术语表列出并解释术语、首字母缩略词和定义。

12 机械、封装和可订购信息

以下页中包括机械、封装和可订购信息。 这些信息是针对指定器件可提供的最新数据。 这些数据会在无通知且不
对本文档进行修订的情况下发生改变。 欲获得该数据表的浏览器版本，请查阅左侧的导航栏。

PACKAGING INFORMATION

Orderable Device	Status (1)	Package Type	Package Drawing	Pins	Package Qty	Eco Plan (2)	Lead finish/ Ball material (6)	MSL Peak Temp (3)	Op Temp (°C)	Device Marking (4/5)	Samples
SN65HVD62RGTR	ACTIVE	VQFN	RGT	16	3000	RoHS & Green	NIPDAU	Level-2-260C-1 YEAR	-40 to 105	HVD62	Samples
SN65HVD62RGTT	ACTIVE	VQFN	RGT	16	250	RoHS & Green	NIPDAU	Level-2-260C-1 YEAR	-40 to 105	HVD62	Samples

(1) The marketing status values are defined as follows:

ACTIVE: Product device recommended for new designs.

LIFEBUY: TI has announced that the device will be discontinued, and a lifetime-buy period is in effect.

NRND: Not recommended for new designs. Device is in production to support existing customers, but TI does not recommend using this part in a new design.

PREVIEW: Device has been announced but is not in production. Samples may or may not be available.

OBSELETE: TI has discontinued the production of the device.

(2) **RoHS:** TI defines "RoHS" to mean semiconductor products that are compliant with the current EU RoHS requirements for all 10 RoHS substances, including the requirement that RoHS substance do not exceed 0.1% by weight in homogeneous materials. Where designed to be soldered at high temperatures, "RoHS" products are suitable for use in specified lead-free processes. TI may reference these types of products as "Pb-Free".

RoHS Exempt: TI defines "RoHS Exempt" to mean products that contain lead but are compliant with EU RoHS pursuant to a specific EU RoHS exemption.

Green: TI defines "Green" to mean the content of Chlorine (Cl) and Bromine (Br) based flame retardants meet JS709B low halogen requirements of <=1000ppm threshold. Antimony trioxide based flame retardants must also meet the <=1000ppm threshold requirement.

(3) MSL, Peak Temp. - The Moisture Sensitivity Level rating according to the JEDEC industry standard classifications, and peak solder temperature.

(4) There may be additional marking, which relates to the logo, the lot trace code information, or the environmental category on the device.

(5) Multiple Device Markings will be inside parentheses. Only one Device Marking contained in parentheses and separated by a "~" will appear on a device. If a line is indented then it is a continuation of the previous line and the two combined represent the entire Device Marking for that device.

(6) Lead finish/Ball material - Orderable Devices may have multiple material finish options. Finish options are separated by a vertical ruled line. Lead finish/Ball material values may wrap to two lines if the finish value exceeds the maximum column width.

Important Information and Disclaimer:The information provided on this page represents TI's knowledge and belief as of the date that it is provided. TI bases its knowledge and belief on information provided by third parties, and makes no representation or warranty as to the accuracy of such information. Efforts are underway to better integrate information from third parties. TI has taken and continues to take reasonable steps to provide representative and accurate information but may not have conducted destructive testing or chemical analysis on incoming materials and chemicals. TI and TI suppliers consider certain information to be proprietary, and thus CAS numbers and other limited information may not be available for release.

In no event shall TI's liability arising out of such information exceed the total purchase price of the TI part(s) at issue in this document sold by TI to Customer on an annual basis.

TAPE AND REEL INFORMATION

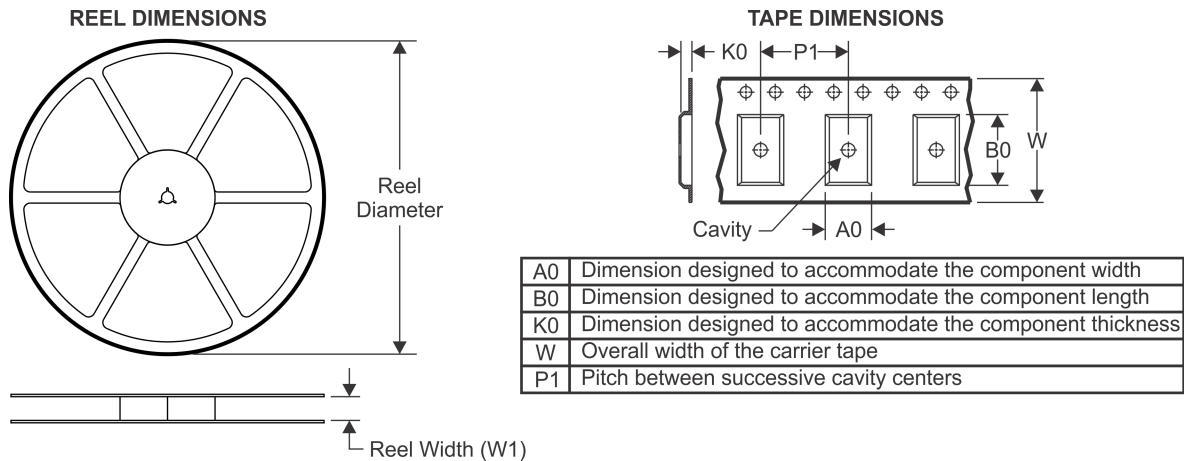

QUADRANT ASSIGNMENTS FOR PIN 1 ORIENTATION IN TAPE

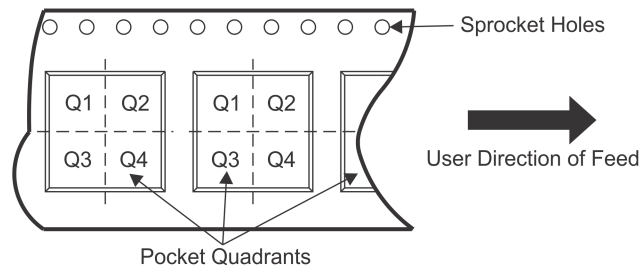

*All dimensions are nominal

Device	Package Type	Package Drawing	Pins	SPQ	Reel Diameter (mm)	Reel Width W1 (mm)	A0 (mm)	B0 (mm)	K0 (mm)	P1 (mm)	W (mm)	Pin1 Quadrant
SN65HVD62RGTR	VQFN	RGT	16	3000	330.0	12.4	3.3	3.3	1.1	8.0	12.0	Q2
SN65HVD62RGTT	VQFN	RGT	16	250	180.0	12.4	3.3	3.3	1.1	8.0	12.0	Q2

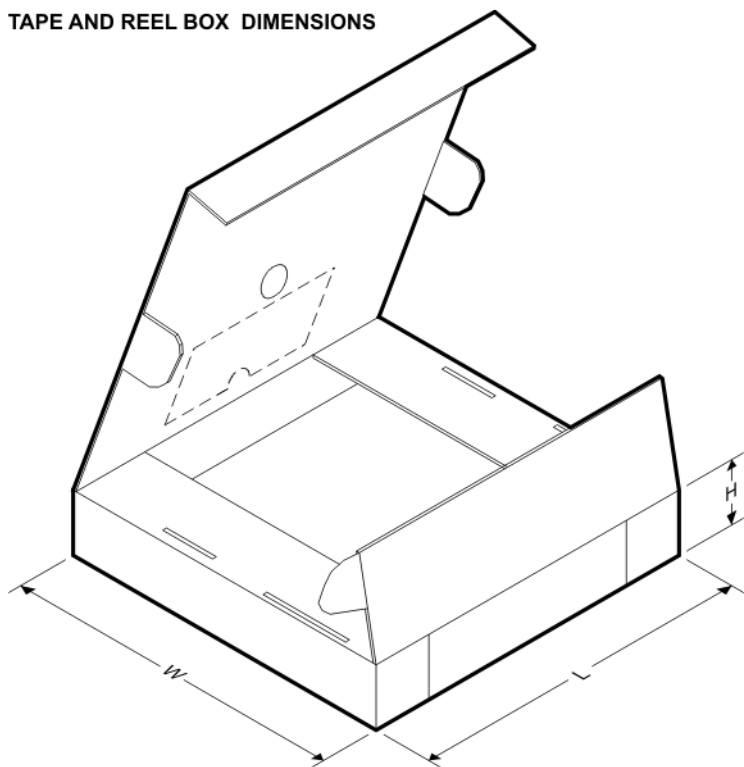
TAPE AND REEL BOX DIMENSIONS

*All dimensions are nominal

Device	Package Type	Package Drawing	Pins	SPQ	Length (mm)	Width (mm)	Height (mm)
SN65HVD62RGTR	VQFN	RGT	16	3000	367.0	367.0	35.0
SN65HVD62RGTT	VQFN	RGT	16	250	210.0	185.0	35.0

RGT 16

GENERIC PACKAGE VIEW

VQFN - 1 mm max height

PLASTIC QUAD FLATPACK - NO LEAD

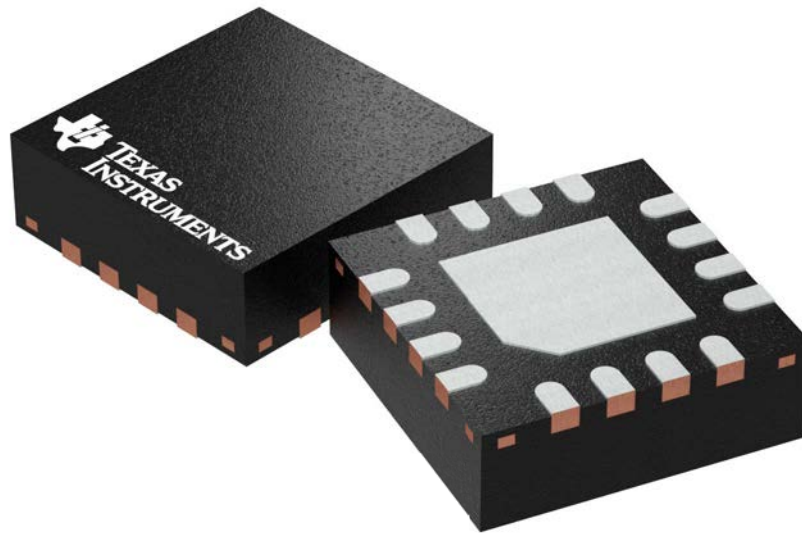

Images above are just a representation of the package family, actual package may vary.
Refer to the product data sheet for package details.

4203495/1

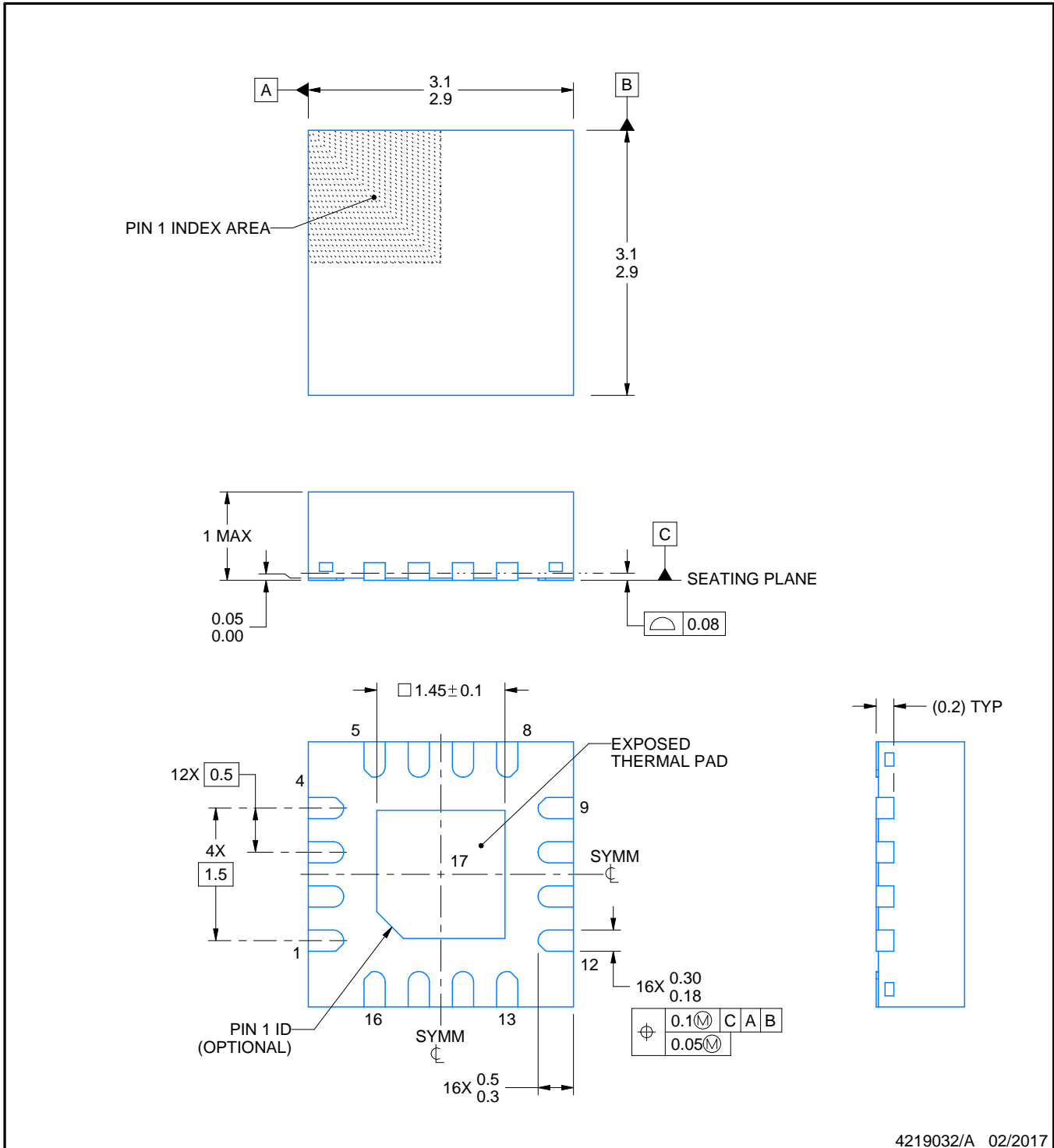
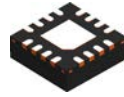

4219032/A 02/2017

NOTES:

1. All linear dimensions are in millimeters. Any dimensions in parenthesis are for reference only. Dimensioning and tolerancing per ASME Y14.5M.
2. This drawing is subject to change without notice.
3. The package thermal pad must be soldered to the printed circuit board for thermal and mechanical performance.
4. Reference JEDEC registration MO-220

EXAMPLE BOARD LAYOUT

RGT0016A

VQFN - 1 mm max height

PLASTIC QUAD FLATPACK - NO LEAD

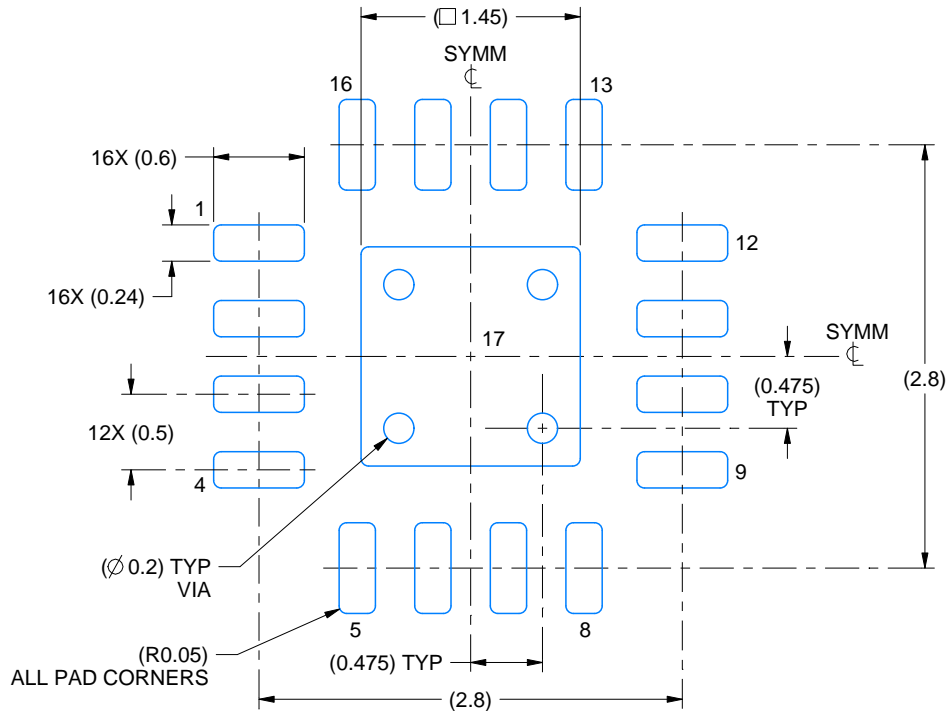

LAND PATTERN EXAMPLE
EXPOSED METAL SHOWN
SCALE:20X

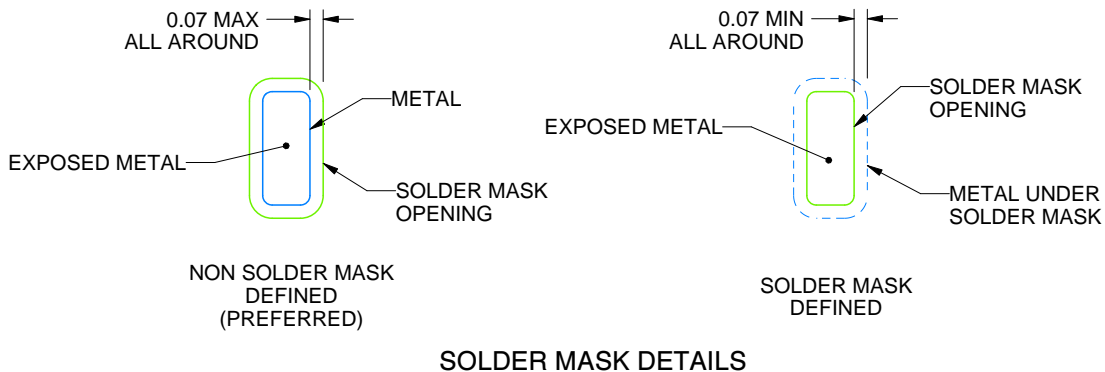

4219032/A 02/2017

NOTES: (continued)

5. This package is designed to be soldered to a thermal pad on the board. For more information, see Texas Instruments literature number SLUA271 (www.ti.com/lit/sluea271).
6. Vias are optional depending on application, refer to device data sheet. If any vias are implemented, refer to their locations shown on this view. It is recommended that vias under paste be filled, plugged or tented.

EXAMPLE STENCIL DESIGN

RGT0016A

VQFN - 1 mm max height

PLASTIC QUAD FLATPACK - NO LEAD

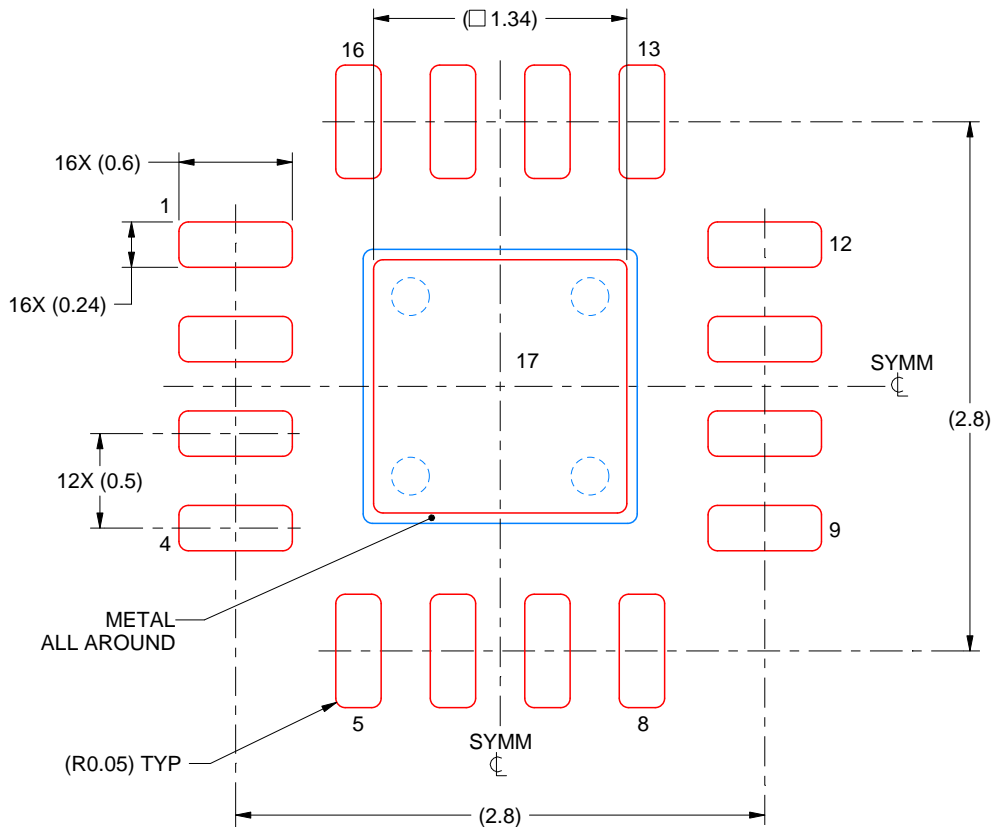

SOLDER PASTE EXAMPLE
BASED ON 0.125 mm THICK STENCIL

EXPOSED PAD 17:
86% PRINTED SOLDER COVERAGE BY AREA UNDER PACKAGE
SCALE:25X

4219032/A 02/2017

NOTES: (continued)

7. Laser cutting apertures with trapezoidal walls and rounded corners may offer better paste release. IPC-7525 may have alternate design recommendations.

重要声明和免责声明

TI 提供技术和可靠性数据 (包括数据表)、设计资源 (包括参考设计)、应用或其他设计建议、网络工具、安全信息和其他资源, 不保证没有瑕疵且不做任何明示或暗示的担保, 包括但不限于对适销性、某特定用途方面的适用性或不侵犯任何第三方知识产权的暗示担保。

这些资源可供使用 TI 产品进行设计的熟练开发人员使用。您将自行承担以下全部责任: (1) 针对您的应用选择合适的 TI 产品, (2) 设计、验证并测试您的应用, (3) 确保您的应用满足相应标准以及任何其他安全、安保或其他要求。这些资源如有变更, 恕不另行通知。TI 授权您仅可将这些资源用于研发本资源所述的 TI 产品的应用。严禁对这些资源进行其他复制或展示。您无权使用任何其他 TI 知识产权或任何第三方知识产权。您应全额赔偿因在这些资源的使用中对 TI 及其代表造成的任何索赔、损害、成本、损失和债务, TI 对此概不负责。

TI 提供的产品受 TI 的销售条款 (<https://www.ti.com.cn/zh-cn/legal/termsofsale.html>) 或 [ti.com.cn](https://www.ti.com.cn) 上其他适用条款/TI 产品随附的其他适用条款的约束。TI 提供这些资源并不会扩展或以其他方式更改 TI 针对 TI 产品发布的适用的担保或担保免责声明。

邮寄地址: 上海市浦东新区世纪大道 1568 号中建大厦 32 楼, 邮政编码: 200122
Copyright © 2021 德州仪器半导体技术 (上海) 有限公司