

# LPC662

*LPC662 Low Power CMOS Dual Operational Amplifier*



Literature Number: SNOS555B

## LPC662

# Low Power CMOS Dual Operational Amplifier

### General Description

The LPC662 CMOS Dual operational amplifier is ideal for operation from a single supply. It features a wide range of operating voltage from +5V to +15V, rail-to-rail output swing in addition to an input common-mode range that includes ground. Performance limitations that have plagued CMOS amplifiers in the past are not a problem with this design. Input  $V_{OS}$ , drift, and broadband noise as well as voltage gain (into 100 k $\Omega$  and 5 k $\Omega$ ) are all equal to or better than widely accepted bipolar equivalents, while the power supply requirement is typically less than 0.5 mW.

This chip is built with National's advanced Double-Poly Silicon-Gate CMOS process.

See the LPC660 datasheet for a Quad CMOS operational amplifier and LPC661 for a single CMOS operational amplifier with these same features.

### Applications

- High-impedance buffer
- Precision current-to-voltage converter

- Long-term integrator
- High-impedance preamplifier
- Active filter
- Sample-and-Hold circuit
- Peak detector

### Features

- Rail-to-rail output swing
- Micropower operation (<0.5 mW)
- Specified for 100 k $\Omega$  and 5 k $\Omega$  loads
- High voltage gain
- Low input offset voltage
- Low offset voltage drift
- Ultra low input bias current
- Input common-mode includes GND
- Operating range from +5V to +15V
- Low distortion
- Slew rate
- Full military temperature range available

120 dB  
3 mV  
1.3  $\mu\text{V}/^\circ\text{C}$   
2 fA

0.01% at 1 kHz  
0.11 V/ $\mu\text{s}$

### Application Circuit

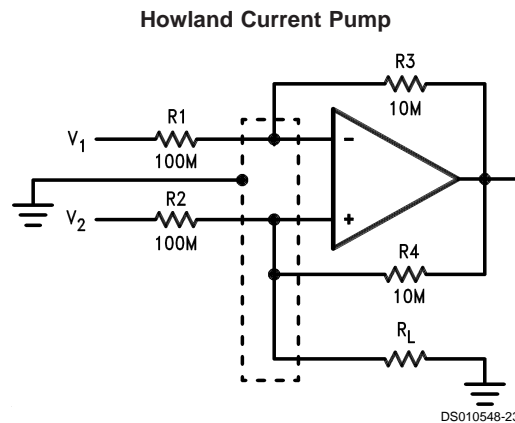

**Absolute Maximum Ratings** (Note 3)

If Military/Aerospace specified devices are required, please contact the National Semiconductor Sales Office/Distributors for availability and specifications.

Differential Input Voltage	±Supply Voltage
Supply Voltage ( $V^+ - V^-$ )	16V
Output Short Circuit to $V^+$	(Note 11)
Output Short Circuit to $V^-$	(Note 1)
Lead Temperature (Soldering, 10 sec.)	260°C
Storage Temp. Range	-65°C to +150°C
Junction Temperature	150°C
ESD Rating (C = 100 pF, R = 1.5 kΩ)	1000V
Power Dissipation	(Note 2)
Current at Input Pin	±5 mA
Current at Output Pin	±18 mA

Current at Power Supply Pin	35 mA
Voltage at Input/Output Pin	( $V^+$ ) + 0.3V, ( $V^-$ ) -0.3V

**Operating Ratings** (Note 3)

Temperature Range	
LPC662AMJ/883	-55°C ≤ $T_J$ ≤ +125°C
LPC662AM	-55°C ≤ $T_J$ ≤ +125°C
LPC662AI	-40°C ≤ $T_J$ ≤ +85°C
LPC662I	-40°C ≤ $T_J$ ≤ +85°C
Supply Range	4.75V to 15.5V
Power Dissipation	(Note 9)
Thermal Resistance ( $\theta_{JA}$ ) (Note 10)	
8-Pin Ceramic DIP	100°C/W
8-Pin Molded DIP	101°C/W
8-Pin SO	165°C/W
8-Pin Side Brazed Ceramic DIP	100°C/W

**DC Electrical Characteristics**

Unless otherwise specified, all limits guaranteed for  $T_J = 25^\circ\text{C}$ . **Boldface** limits apply at the temperature extremes.  $V^+ = 5\text{V}$ ,  $V^- = 0\text{V}$ ,  $V_{CM} = 1.5\text{V}$ ,  $V_O = 2.5\text{V}$  and  $R_L > 1\text{M}$  unless otherwise specified.

Parameter	Conditions	Typ	LPC662AM LPC662AMJ/883 Limit (Notes 4, 8)	LPC662AI Limit (Note 4)	LPC662I Limit (Note 4)	Units
Input Offset Voltage		1	3	3	6	mV
			<b>3.5</b>	<b>3.3</b>	<b>6.3</b>	max
Input Offset Voltage Average Drift		1.3				$\mu\text{V}/^\circ\text{C}$
Input Bias Current		0.002	20			pA
			<b>100</b>	<b>4</b>	<b>4</b>	max
Input Offset Current		0.001	20			pA
			<b>100</b>	<b>2</b>	<b>2</b>	max
Input Resistance		>1				Tera $\Omega$
Common Mode Rejection Ratio	$0\text{V} \leq V_{CM} \leq 12.0\text{V}$ $V^+ = 15\text{V}$	83	70	70	63	dB
			<b>68</b>	<b>68</b>	<b>61</b>	min
Positive Power Supply Rejection Ratio	$5\text{V} \leq V^+ \leq 15\text{V}$ $V_O = 2.5\text{V}$	83	70	70	63	dB
			<b>68</b>	<b>68</b>	<b>61</b>	min
Negative Power Supply Rejection Ratio	$0\text{V} \leq V^- \leq -10\text{V}$	94	84	84	74	dB
			<b>82</b>	<b>83</b>	<b>73</b>	min
Input Common-Mode Voltage Range	$V^+ = 5\text{V}$ and 15V For CMRR ≥ 50 dB	-0.4	-0.1	-0.1	-0.1	V
			<b>0</b>	<b>0</b>	<b>0</b>	max
			$V^+ - 1.9$	$V^+ - 2.3$	$V^+ - 2.3$	$V^+ - 2.3$
Large Signal Voltage Gain	$R_L = 100\text{ k}\Omega$ (Note 5) Sourcing	1000	400	400	300	V/mV
			<b>250</b>	<b>300</b>	<b>200</b>	min
			500	180	180	90
	<b>70</b>	<b>120</b>		<b>70</b>	min	
	$R_L = 5\text{ k}\Omega$ (Note 5) Sourcing	1000		200	200	100
		250	<b>150</b>	<b>160</b>	<b>80</b>	min
Sinking			100	100	50	V/mV
	<b>35</b>	<b>60</b>	<b>40</b>	min		

**DC Electrical Characteristics** (Continued)

Unless otherwise specified, all limits guaranteed for  $T_J = 25^\circ\text{C}$ . **Boldface** limits apply at the temperature extremes.  $V^+ = 5\text{V}$ ,  $V^- = 0\text{V}$ ,  $V_{\text{CM}} = 1.5\text{V}$ ,  $V_{\text{O}} = 2.5\text{V}$  and  $R_L > 1\text{M}$  unless otherwise specified.

Parameter	Conditions	Typ	LPC662AM LPC662AMJ/883 Limit (Notes 4, 8)	LPC662AI Limit (Note 4)	LPC662I Limit (Note 4)	Units
Output Swing	$V^+ = 5\text{V}$ $R_L = 100\text{ k}\Omega$ to $V^+/2$	4.987	4.970	4.970	4.940	V
			<b>4.950</b>	<b>4.950</b>	<b>4.910</b>	min
		0.004	0.030	0.030	0.060	V
			<b>0.050</b>	<b>0.050</b>	<b>0.090</b>	max
	$V^+ = 5\text{V}$ $R_L = 5\text{ k}\Omega$ to $V^+/2$	4.940	4.850	4.850	4.750	V
			<b>4.750</b>	<b>4.750</b>	<b>4.650</b>	min
		0.040	0.150	0.150	0.250	V
			<b>0.250</b>	<b>0.250</b>	<b>0.350</b>	max
	$V^+ = 15\text{V}$ $R_L = 100\text{ k}\Omega$ to $V^+/2$	14.970	14.920	14.920	14.880	V
			<b>14.880</b>	<b>14.880</b>	<b>14.820</b>	min
		0.007	0.030	0.030	0.060	V
			<b>0.050</b>	<b>0.050</b>	<b>0.090</b>	max
$V^+ = 15\text{V}$ $R_L = 5\text{ k}\Omega$ to $V^+/2$	14.840	14.680	14.680	14.580	V	
		<b>14.600</b>	<b>14.600</b>	<b>14.480</b>	min	
	0.110	0.220	0.220	0.320	V	
		<b>0.300</b>	<b>0.300</b>	<b>0.400</b>	max	
Output Current $V^+ = 5\text{V}$	Sourcing, $V_{\text{O}} = 0\text{V}$	22	16	16	13	mA
			<b>12</b>	<b>14</b>	<b>11</b>	min
	Sinking, $V_{\text{O}} = 5\text{V}$	21	16	16	13	mA
			<b>12</b>	<b>14</b>	<b>11</b>	min
Output Current $V^+ = 15\text{V}$	Sourcing, $V_{\text{O}} = 0\text{V}$	40	19	28	23	mA
			<b>19</b>	<b>25</b>	<b>20</b>	min
	Sinking, $V_{\text{O}} = 13\text{V}$ (Note 11)	39	19	28	23	mA
			<b>19</b>	<b>24</b>	<b>19</b>	min
Supply Current	Both Amplifiers $V_{\text{O}} = 1.5\text{V}$	86	120	120	140	$\mu\text{A}$
			<b>145</b>	<b>140</b>	<b>160</b>	max

## AC Electrical Characteristics

Unless otherwise specified, all limits guaranteed for  $T_J = 25^\circ\text{C}$ . **Boldface** limits apply at the temperature extremes.  $V^+ = 5\text{V}$ ,  $V^- = 0\text{V}$ ,  $V_{\text{CM}} = 1.5\text{V}$ ,  $V_{\text{O}} = 2.5\text{V}$  and  $R_L > 1\text{M}$  unless otherwise specified.

Parameter	Conditions	Typ	LPC662AM LPC662AMJ/883 Limit (Notes 4, 8)	LPC662AI Limit (Note 4)	LPC662I Limit (Note 4)	Units
Slew Rate	(Note 6)	0.11	0.07	0.07	0.05	V/ $\mu\text{s}$
			<b>0.04</b>	<b>0.05</b>	<b>0.03</b>	min
Gain-Bandwidth Product		0.35				MHz
Phase Margin		50				Deg
Gain Margin		17				dB
Amp-to-Amp Isolation	(Note 7)	130				dB
Input Referred Voltage Noise	F = 1 kHz	42				nV/ $\sqrt{\text{Hz}}$
Input Referred Current Noise	F = 1 kHz	0.0002				pA/ $\sqrt{\text{Hz}}$
Total Harmonic Distortion	F = 1 kHz, $A_V = -10$ , $V^+ = 15\text{V}$ $R_L = 100\text{ k}\Omega$ , $V_{\text{O}} = 8\text{ V}_{\text{PP}}$	0.01				%

**Note 1:** Applies to both single supply and split supply operation. Continuous short circuit operation at elevated ambient temperature and/or multiple Op Amp shorts can result in exceeding the maximum allowed junction temperature of  $150^\circ\text{C}$ . Output currents in excess of  $\pm 30\text{ mA}$  over long term may adversely affect reliability.

**Note 2:** The maximum power dissipation is a function of  $T_{\text{J(max)}}$ ,  $\theta_{\text{JA}}$ , and  $T_{\text{A}}$ . The maximum allowable power dissipation at any ambient temperature is  $P_{\text{D}} = (T_{\text{J(max)}} - T_{\text{A}})/\theta_{\text{JA}}$ .

**Note 3:** Absolute Maximum Ratings indicate limits beyond which damage to the device may occur. Operating Ratings indicate conditions for which the device is intended to be functional, but do not guarantee specific performance limits. For guaranteed specifications and test conditions, see the Electrical Characteristics. The guaranteed specifications apply only for the test conditions listed.

**Note 4:** Limits are guaranteed by testing or correlation.

**Note 5:**  $V^+ = 15\text{V}$ ,  $V_{\text{CM}} = 7.5\text{V}$  and  $R_L$  connected to  $7.5\text{V}$ . For Sourcing tests,  $7.5\text{V} \leq V_{\text{O}} \leq 11.5\text{V}$ . For Sinking tests,  $2.5\text{V} \leq V_{\text{O}} \leq 7.5\text{V}$ .

**Note 6:**  $V^+ = 15\text{V}$ . Connected as Voltage Follower with  $10\text{V}$  step input. Number specified is the slower of the positive and negative slew rates.

**Note 7:** Input referred.  $V^+ = 15\text{V}$  and  $R_L = 100\text{ k}\Omega$  connected to  $V^+/2$ . Each amp excited in turn with  $1\text{ kHz}$  to produce  $V_{\text{O}} = 13\text{ V}_{\text{PP}}$ .

**Note 8:** A military RETS electrical test specification is available on request. At the time of printing, the LPC662AMJ/883 RETS specification complied fully with the **boldface** limits in this column. The LPC662AMJ/883 may also be procured to a Standard Military Drawing specification.

**Note 9:** For operating at elevated temperatures the device must be derated based on the thermal resistance  $\theta_{\text{JA}}$  with  $P_{\text{D}} = (T_{\text{J}} - T_{\text{A}})/\theta_{\text{JA}}$ .

**Note 10:** All numbers apply for packages soldered directly into a PC board.

**Note 11:** Do not connect output to  $V^+$  when  $V^+$  is greater than  $13\text{V}$  or reliability may be adversely affected.

# Typical Performance Characteristics $V_S = \pm 7.5V, T_A = 25^\circ C$ unless otherwise specified

**Supply Current vs Supply Voltage**

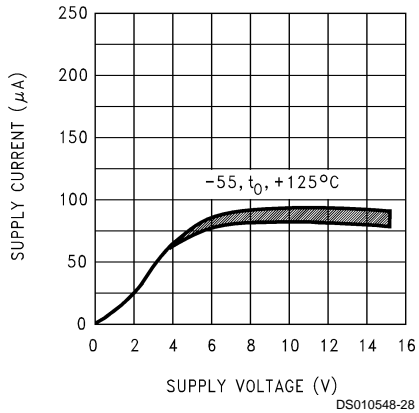

**Input Bias Current vs Temperature**

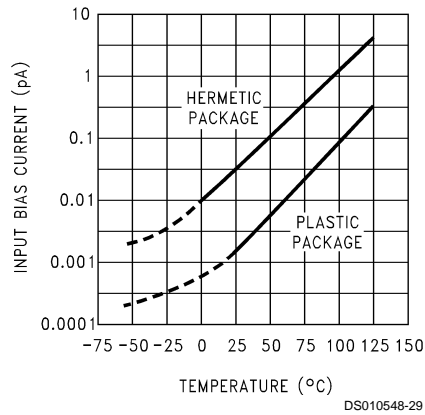

**Input Common-Mode Voltage Range vs Temperature**

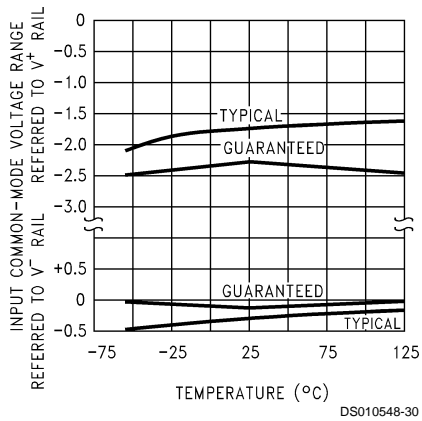

**Output Characteristics Current Sinking**

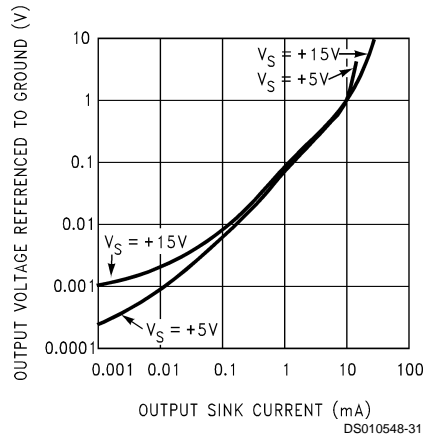

**Output Characteristics Current Sourcing**

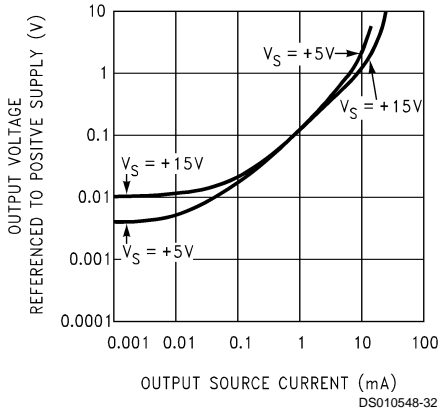

**Input Voltage Noise vs Frequency**

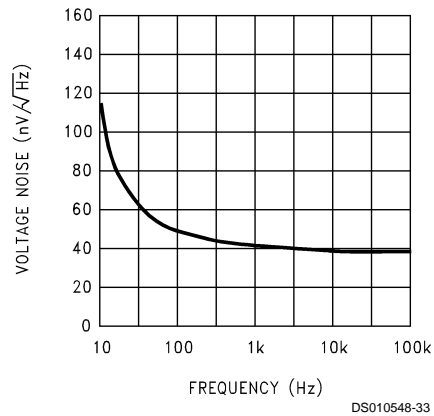

**Typical Performance Characteristics**  $V_S = \pm 7.5V$ ,  $T_A = 25^\circ C$  unless otherwise specified (Continued)

**Crosstalk Rejection vs Frequency**

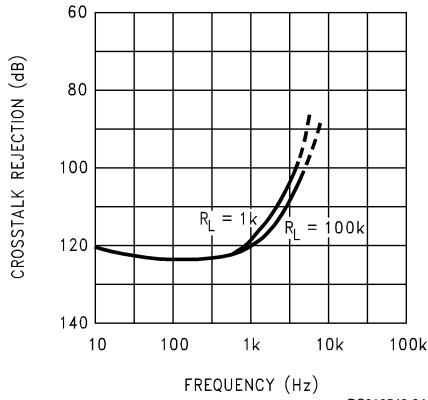

**CMRR vs Frequency**

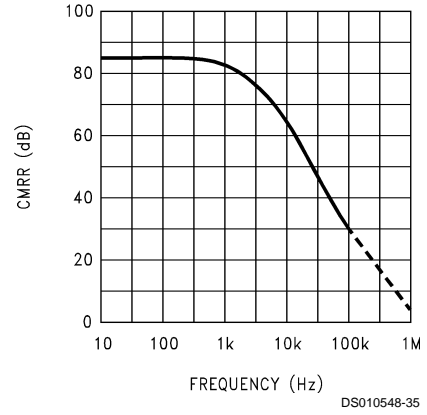

**CMRR vs Temperature**

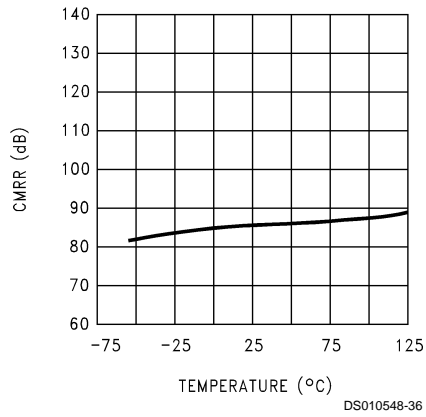

**Open-Loop Voltage Gain vs Temperature**

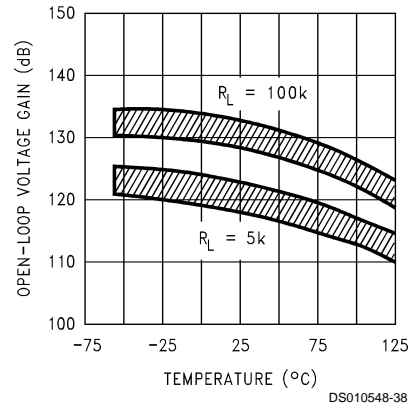

**Open-Loop Frequency Response**

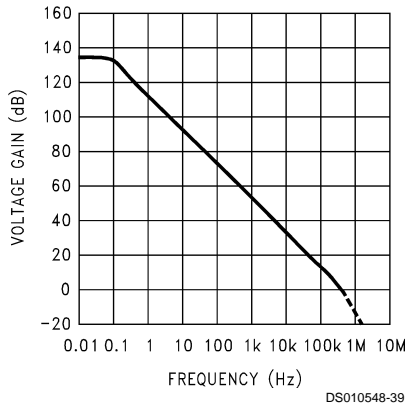

**Gain and Phase Responses vs Load Capacitance**

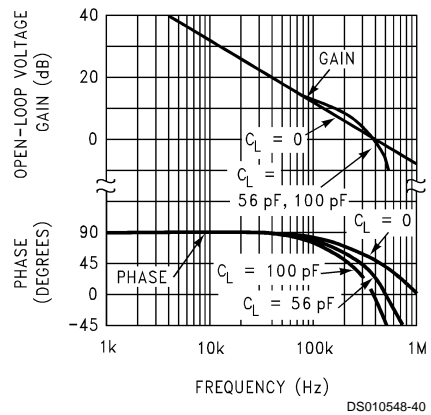

**Typical Performance Characteristics**  $V_S = \pm 7.5V$ ,  $T_A = 25^\circ C$  unless otherwise specified (Continued)

**Gain and Phase Responses vs Temperature**

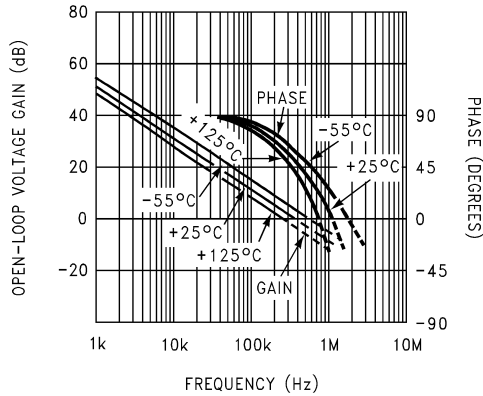

**Gain Error ( $V_{OS}$  vs  $V_{OUT}$ )**

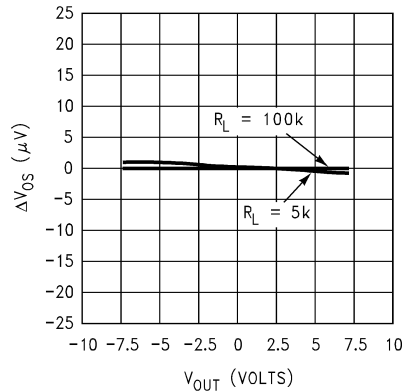

**Non-Inverting Slew Rate vs Temperature**

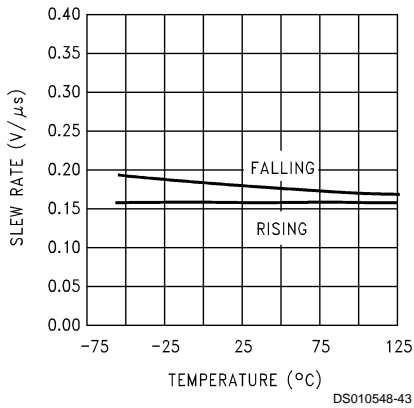

**Inverting Slew Rate vs Temperature**

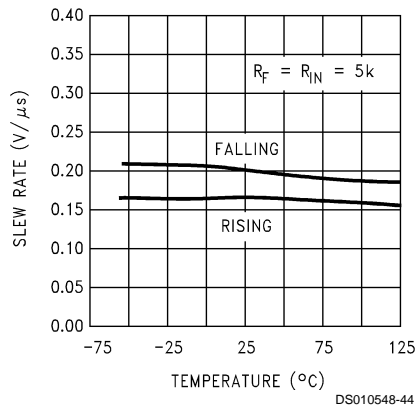

**Large-Signal Pulse Non-Inverting Response ( $A_V = +1$ )**

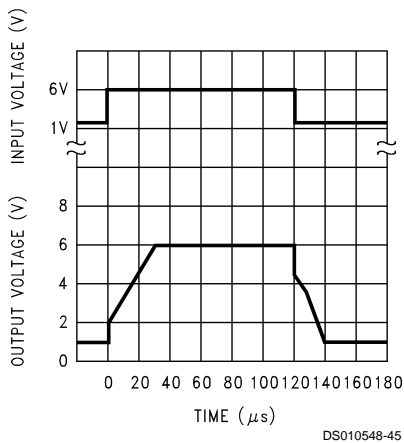

**Non-Inverting Small Signal Pulse Response ( $A_V = +1$ )**

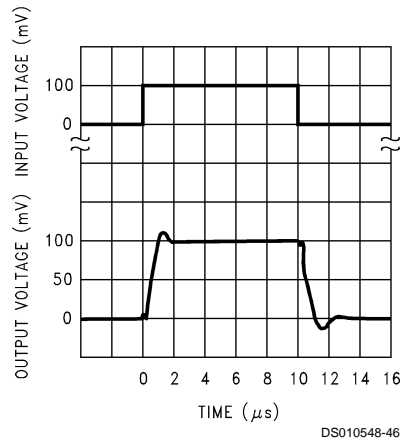

**Typical Performance Characteristics**  $V_S = \pm 7.5V$ ,  $T_A = 25^\circ C$  unless otherwise specified (Continued)

**Inverting Large-Signal Pulse Response**

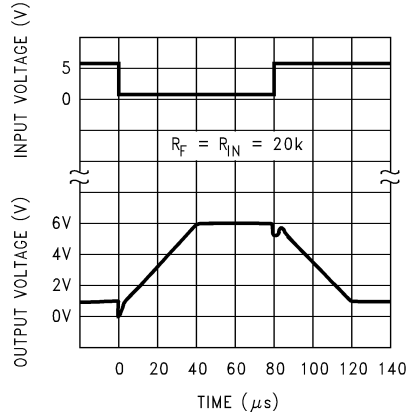

DS010548-47

**Inverting Small-Signal Pulse Response**

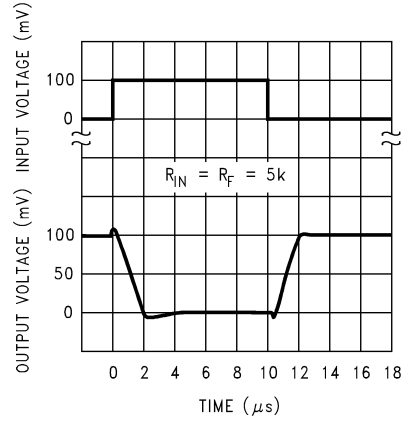

DS010548-48

**Power Supply Rejection Ratio vs Frequency**

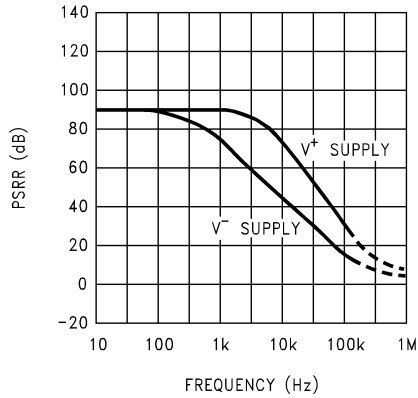

DS010548-37

**Stability vs Capacitive Load**

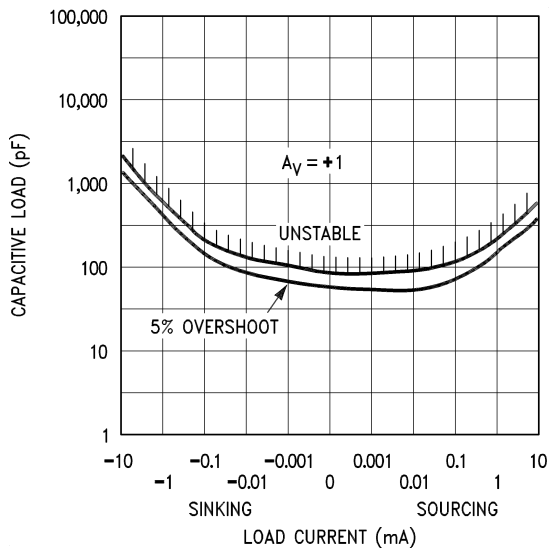

DS010548-4

**Stability vs Capacitive Load**

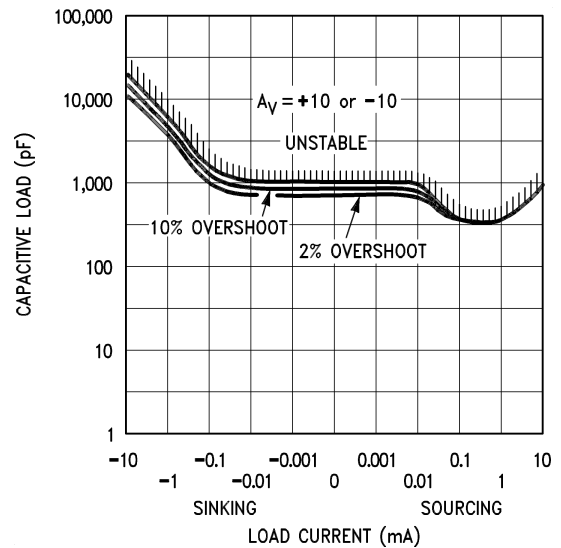

DS010548-5

**Note:** Avoid resistive loads of less than  $500\Omega$ , as they may cause instability.

## Application Hints

### AMPLIFIER TOPOLOGY

The topology chosen for the LPC662 is unconventional (compared to general-purpose op amps) in that the traditional unity-gain buffer output stage is not used; instead, the output is taken directly from the output of the integrator, to allow rail-to-rail output swing. Since the buffer traditionally delivers the power to the load, while maintaining high op amp gain and stability, and must withstand shorts to either rail, these tasks now fall to the integrator.

As a result of these demands, the integrator is a compound affair with an embedded gain stage that is doubly fed forward (via  $C_f$  and  $C_{ff}$ ) by a dedicated unity-gain compensation driver. In addition, the output portion of the integrator is a push-pull configuration for delivering heavy loads. While sinking current the whole amplifier path consists of three gain stages with one stage fed forward, whereas while sourcing the path contains four gain stages with two fed forward.

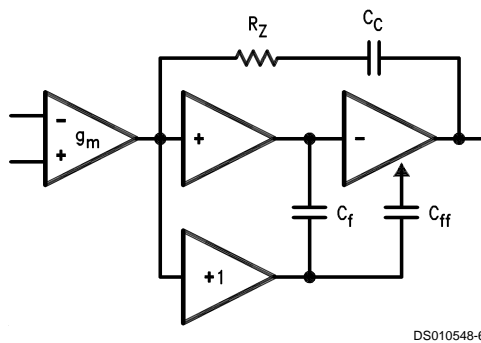

FIGURE 1. LPC662 Circuit Topology (Each Amplifier)

The large signal voltage gain while sourcing is comparable to traditional bipolar op amps for load resistance of at least 5 k $\Omega$ . The gain while sinking is higher than most CMOS op amps, due to the additional gain stage; however, when driving load resistance of 5 k $\Omega$  or less, the gain will be reduced as indicated in the Electrical Characteristics. The op amp can drive load resistance as low as 500 $\Omega$  without instability.

### COMPENSATING INPUT CAPACITANCE

Refer to the LMC660 or LMC662 datasheets to determine whether or not a feedback capacitor will be necessary for compensation and what the value of that capacitor would be.

### CAPACITIVE LOAD TOLERANCE

Like many other op amps, the LPC662 may oscillate when its applied load appears capacitive. The threshold of oscillation varies both with load and circuit gain. The configuration most sensitive to oscillation is a unity-gain follower. See the Typical Performance Characteristics.

The load capacitance interacts with the op amp's output resistance to create an additional pole. If this pole frequency is sufficiently low, it will degrade the op amp's phase margin so that the amplifier is no longer stable at low gains. The addition of a small resistor (50 $\Omega$  to 100 $\Omega$ ) in series with the op amp's output, and a capacitor (5 pF to 10 pF) from inverting input to output pins, returns the phase margin to a safe value without interfering with lower-frequency circuit operation. Thus, larger values of capacitance can be

tolerated without oscillation. Note that in all cases, the output will ring heavily when the load capacitance is near the threshold for oscillation.

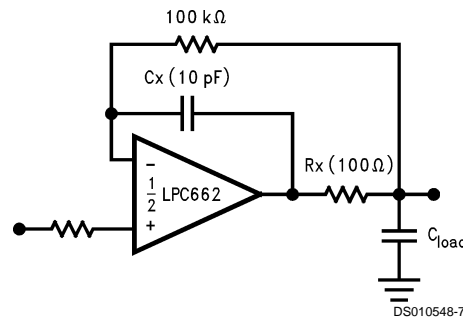

FIGURE 2. Rx, Cx Improve Capacitive Load Tolerance

Capacitive load driving capability is enhanced by using a pull up resistor to  $V^+$  Figure 3. Typically a pull up resistor conducting 50  $\mu$ A or more will significantly improve capacitive load responses. The value of the pull up resistor must be determined based on the current sinking capability of the amplifier with respect to the desired output swing. Open loop gain of the amplifier can also be affected by the pull up resistor (see Electrical Characteristics).

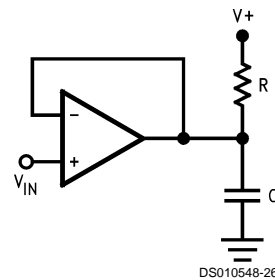

FIGURE 3. Compensating for Large Capacitive Loads with A Pull Up Resistor

### PRINTED-CIRCUIT-BOARD LAYOUT FOR HIGH-IMPEDANCE WORK

It is generally recognized that any circuit which must operate with less than 1000 pA of leakage current requires special layout of the PC board. When one wishes to take advantage of the ultra-low bias current of the LPC662, typically less than 0.04 pA, it is essential to have an excellent layout. Fortunately, the techniques for obtaining low leakages are quite simple. First, the user must not ignore the surface leakage of the PC board, even though it may sometimes appear acceptably low, because under conditions of high humidity or dust or contamination, the surface leakage will be appreciable.

To minimize the effect of any surface leakage, lay out a ring of foil completely surrounding the LPC662's inputs and the terminals of capacitors, diodes, conductors, resistors, relay terminals, etc. connected to the op-amp's inputs. See Figure 4. To have a significant effect, guard rings should be placed on both the top and bottom of the PC board. This PC foil must then be connected to a voltage which is at the same voltage as the amplifier inputs, since no leakage current can flow between two points at the same potential. For example, a PC board trace-to-pad resistance of  $10^{12}$  ohms, which is normally considered a very large resistance, could leak 5 pA if the trace were a 5V bus adjacent to the pad of an input.

### Application Hints (Continued)

This would cause a 100 times degradation from the LPC662's actual performance. However, if a guard ring is held within 5 mV of the inputs, then even a resistance of  $10^{11}$  ohms would cause only 0.05 pA of leakage current, or perhaps a minor (2:1) degradation of the amplifier's

performance. See *Figure 5a*, *Figure 5b*, *Figure 5c* for typical connections of guard rings for standard op-amp configurations. If both inputs are active and at high impedance, the guard can be tied to ground and still provide some protection; see *Figure 5d*.

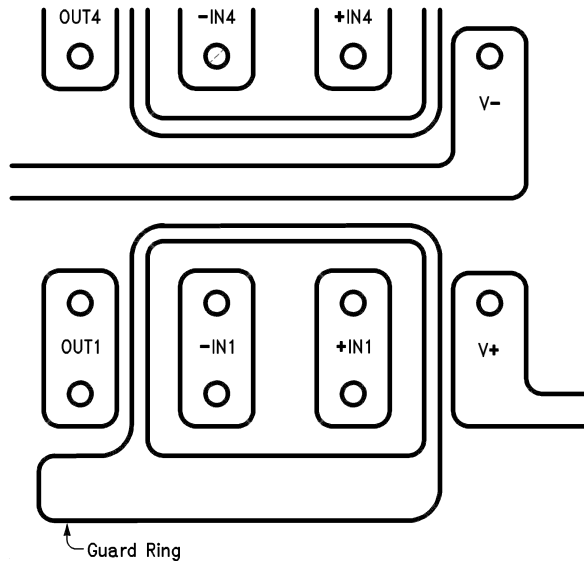

DS010548-19

FIGURE 4. Example of Guard Ring in P.C. Board Layout, using the LPC660

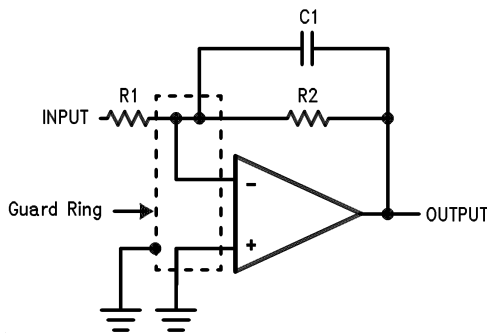

DS010548-20

(a) Inverting Amplifier

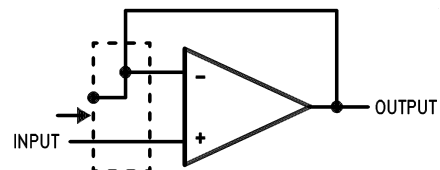

DS010548-22

(c) Follower

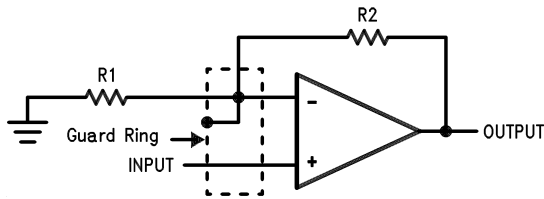

DS010548-21

(b) Non-Inverting Amplifier

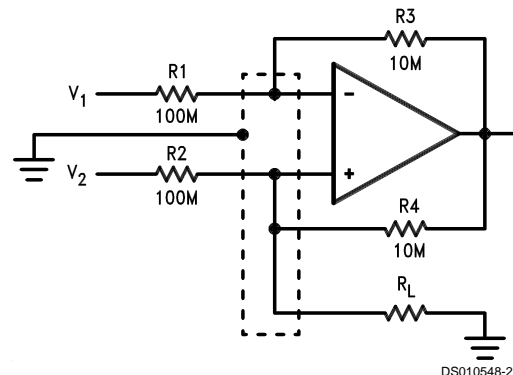

DS010548-23

(d) Howland Current Pump

FIGURE 5. Guard Ring Connections

The designer should be aware that when it is inappropriate to lay out a PC board for the sake of just a few circuits, there

is another technique which is even better than a guard ring on a PC board: Don't insert the amplifier's input pin into the

## Application Hints (Continued)

board at all, but bend it up in the air and use only air as an insulator. Air is an excellent insulator. In this case you may have to forego some of the advantages of PC board construction, but the advantages are sometimes well worth the effort of using point-to-point up-in-the-air wiring. See Figure 6.

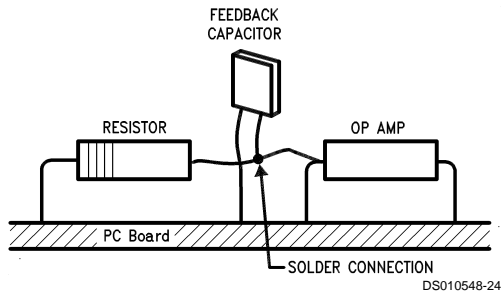

(Input pins are lifted out of PC board and soldered directly to components. All other pins connected to PC board.)

FIGURE 6. Air Wiring

### BIAS CURRENT TESTING

The test method of Figure 7 is appropriate for bench-testing bias current with reasonable accuracy. To understand its operation, first close switch S2 momentarily. When S2 is opened, then

$$I^- = \frac{dV_{OUT}}{dt} \times C2.$$

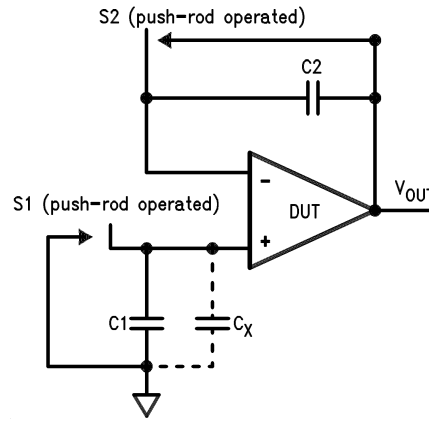

FIGURE 7. Simple Input Bias Current Test Circuit

A suitable capacitor for C2 would be a 5 pF or 10 pF silver mica, NPO ceramic, or air-dielectric. When determining the magnitude of  $I^-$ , the leakage of the capacitor and socket must be taken into account. Switch S2 should be left shorted most of the time, or else the dielectric absorption of the capacitor C2 could cause errors.

Similarly, if S1 is shorted momentarily (while leaving S2 shorted)

$$I^+ = \frac{dV_{OUT}}{dt} \times (C1 + C_x)$$

where  $C_x$  is the stray capacitance at the + input.

## Typical Single-Supply Applications $(V^+ = 5.0 V_{DC})$

### Photodiode Current-to-Voltage Converter

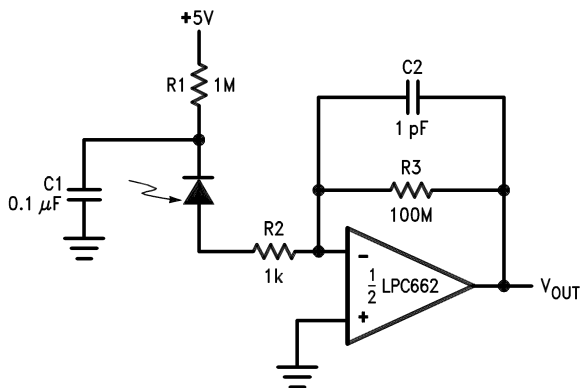

**Note:** A 5V bias on the photodiode can cut its capacitance by a factor of 2 or 3, leading to improved response and lower noise. However, this bias on the photodiode will cause photodiode leakage (also known as its dark current).

### Micropower Current Source

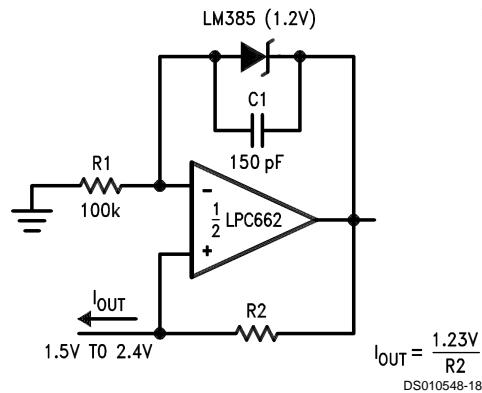

**Note:** (Upper limit of output range dictated by input common-mode range; lower limit dictated by minimum current requirement of LM385.)

## Typical Single-Supply Applications $(V^+ = 5.0 V_{DC})$ (Continued)

### Low-Leakage Sample-and-Hold

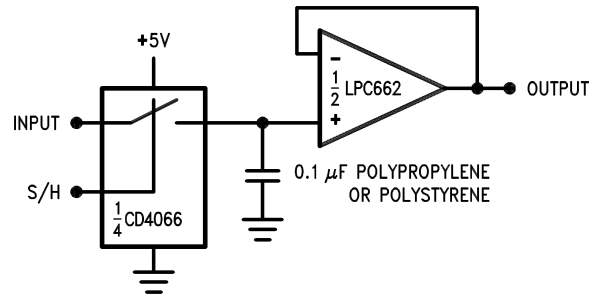

DS010548-8

### Instrumentation Amplifier

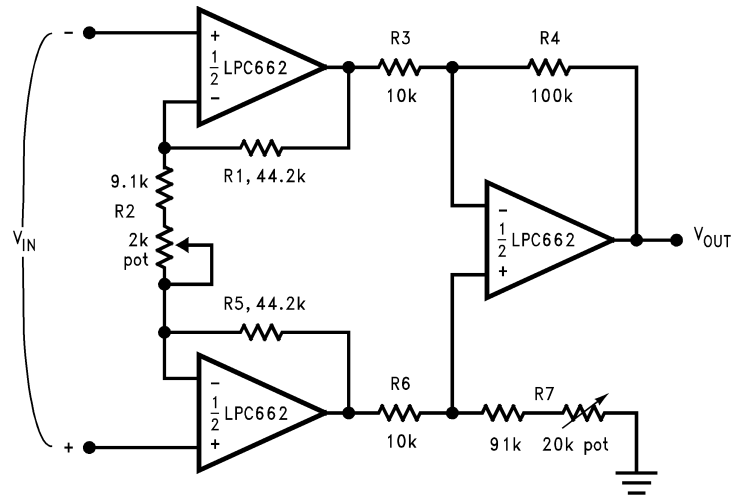

DS010548-9

If  $R1 = R5$ ,  $R3 = R6$  and  $R4 = R7$ ; then

$$\frac{V_{OUT}}{V_{IN}} = \frac{R2 + 2R1}{R2} \times \frac{R4}{R3}$$

$\therefore A_v \approx 100$  for circuit shown.

For good CMRR over temperature, low drift resistors should be used. Matching of  $R3$  to  $R6$  and  $R4$  to  $R7$  affects CMRR. Gain may be adjusted through  $R2$ . CMRR may be adjusted through  $R7$ .

# Typical Single-Supply Applications (V<sup>+</sup> = 5.0 V<sub>DC</sub>) (Continued)

Sine-Wave Oscillator

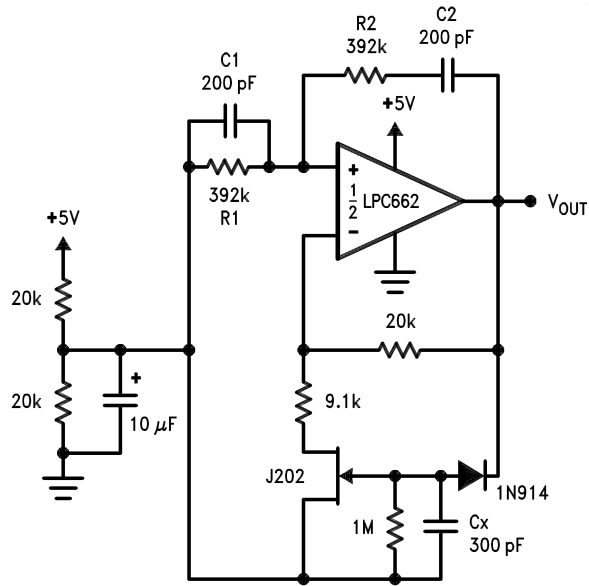

DS010548-10

Oscillator frequency is determined by R1, R2, C1, and C2:

$$f_{OSC} = 1/2\pi RC$$

where R = R1 = R2 and C = C1 = C2.

This circuit, as shown, oscillates at 2.0 kHz with a peak-to-peak output swing of 4.5V

1 Hz Square-Wave Oscillator

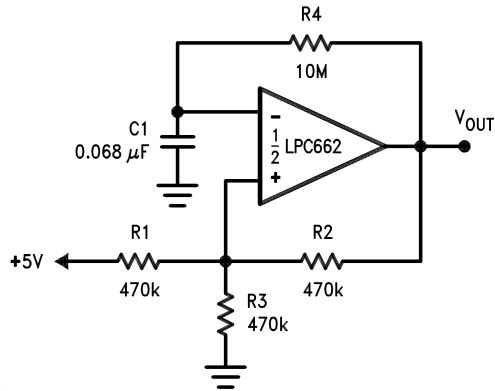

DS010548-11

Power Amplifier

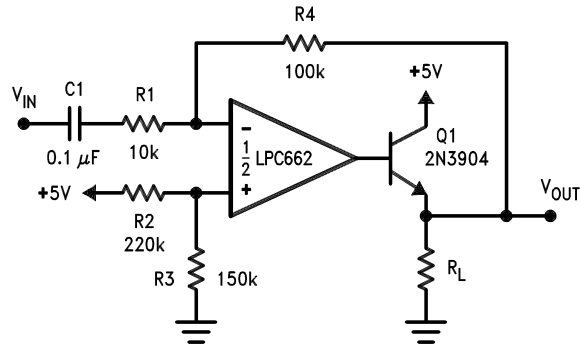

DS010548-12

Typical Single-Supply Applications ( $V^+ = 5.0 V_{DC}$ ) (Continued)

10 Hz Bandpass Filter

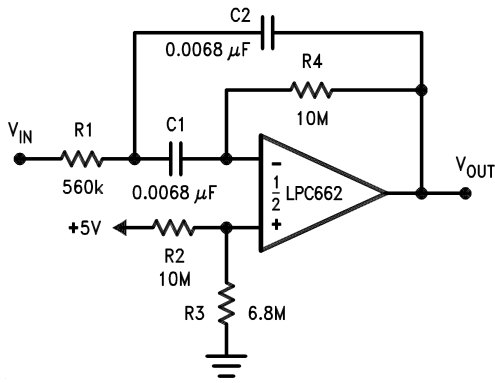

DS010548-13

$f_0 = 10 \text{ Hz}$   
 $Q = 2.1$   
 Gain = -8.8

10 Hz High-Pass Filter (2 dB Dip)

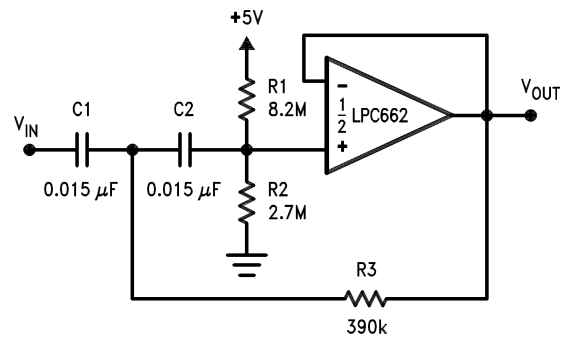

DS010548-14

$f_c = 10 \text{ Hz}$   
 $d = 0.895$   
 Gain = 1

1 Hz Low-Pass Filter  
 (Maximally Flat, Dual Supply Only)

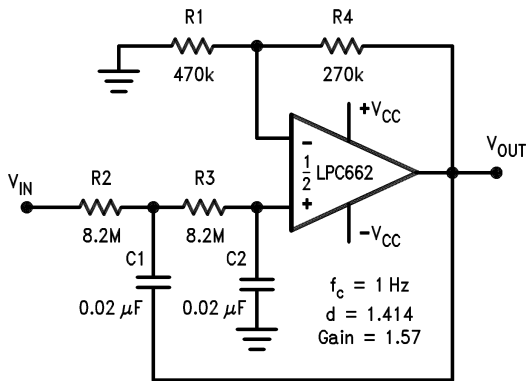

DS010548-15

$f_c = 1 \text{ Hz}$   
 $d = 1.414$   
 Gain = 1.57

High Gain Amplifier with Offset Voltage Reduction

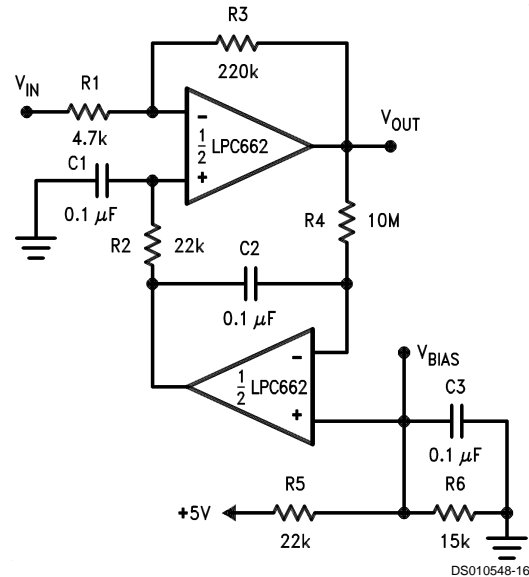

DS010548-16

Gain = -46.8  
 Output offset voltage reduced to the level of the input offset voltage of the bottom amplifier (typically 1 mV), referred to  $V_{BIAS}$ .

## Connection Diagram

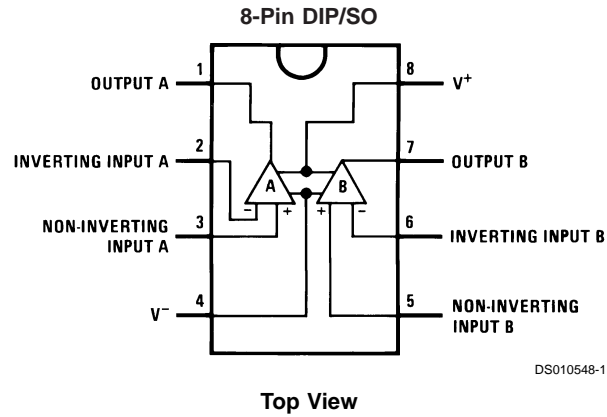

## Ordering Information

Package	Temperature Range		NSC Drawing	Transport Media
	Military	Industrial		
8-Pin Side Brazed Ceramic DIP	LPC662AMD		D08C	Rail
8-Pin Small Outline		LPC662AIM or LPC662IM	M08A	Rail Tape and Reel
8-Pin Molded DIP		LPC662AIN or LPC662IN	N08E	Rail
8-Pin Ceramic DIP	LPC662AMJ/883		J08A	Rail

**Physical Dimensions** inches (millimeters) unless otherwise noted

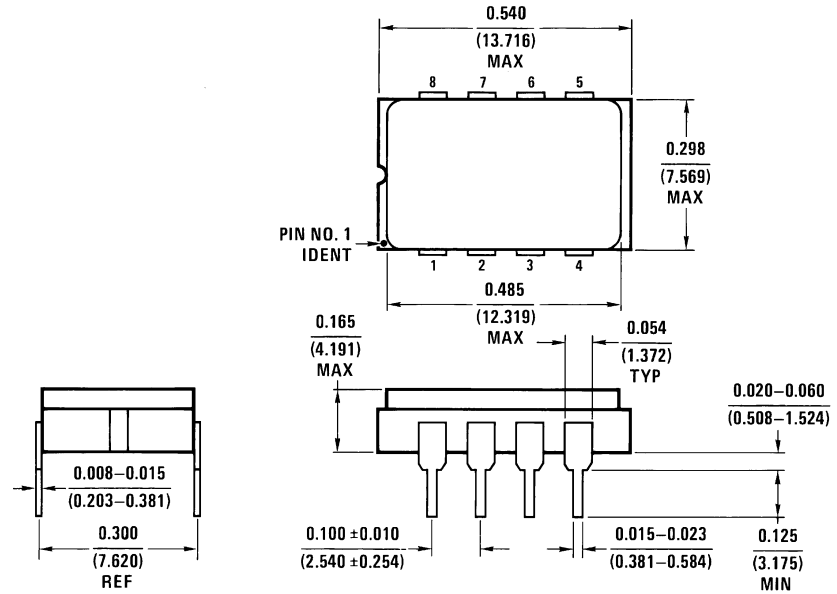

D08C (REV C)

**8-Pin Cavity Dual-In-Line Package (D)**  
**Order Number LPC662AMD**  
**NS Package Number D08C**

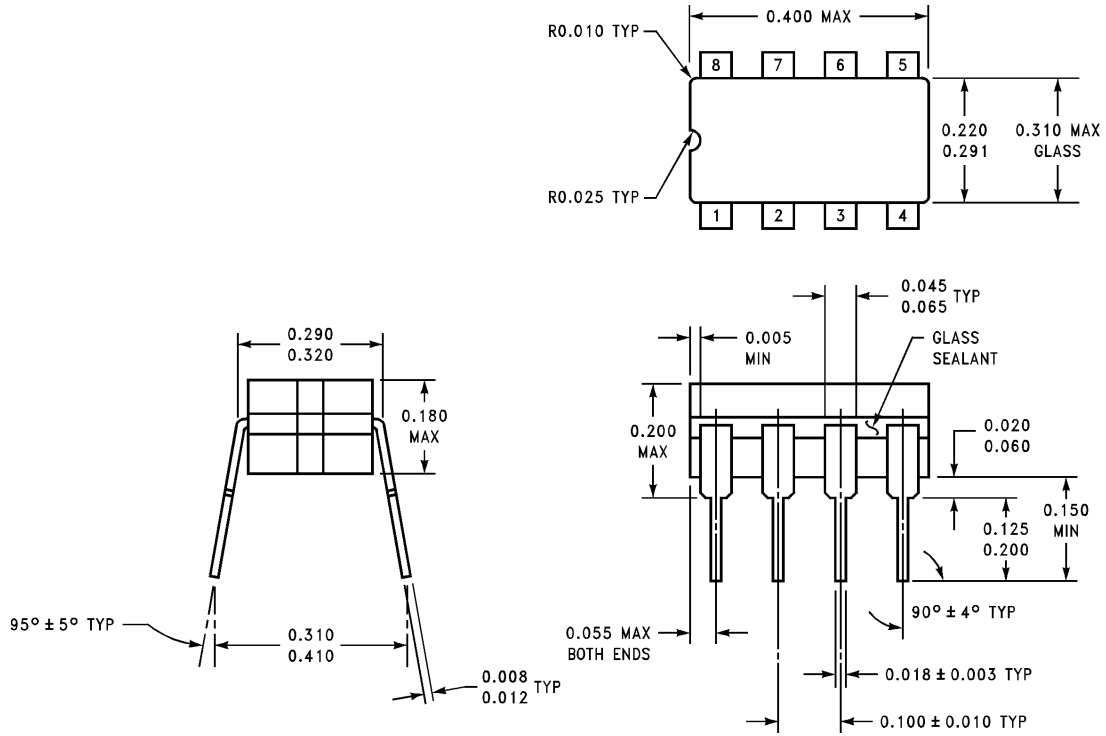

J08A (REV K)

**Ceramic Dual-In-Line Package (J)**  
**Order Number LPC662AMJ/883**  
**NS Package Number J08A**

**Physical Dimensions** inches (millimeters) unless otherwise noted (Continued)

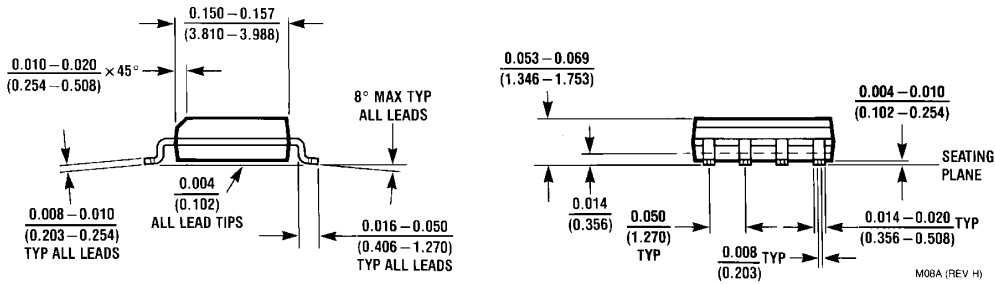
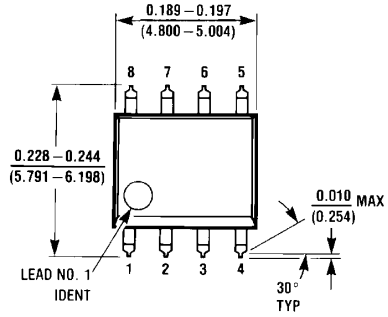

**8-Pin Small Outline Molded Package (M)**  
**Order Number LPC662AIM or LPC662IM**  
**NS Package Number M08A**

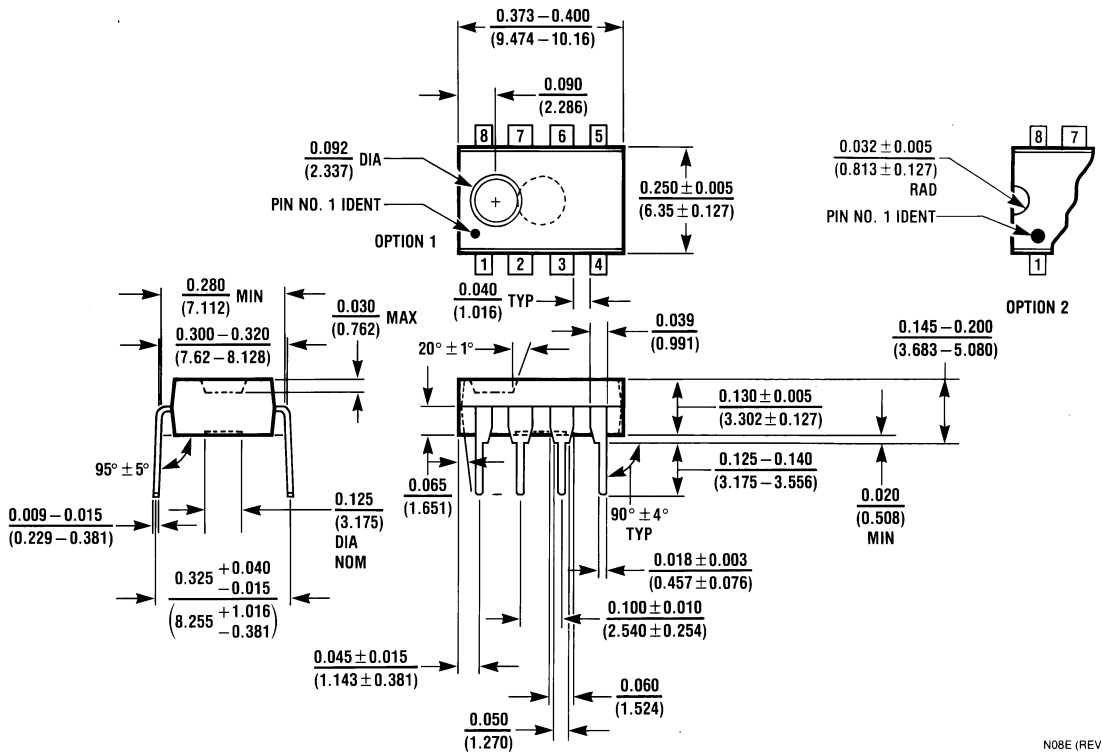

**8-Pin Molded Dual-In-Line Package (N)**  
**Order Number LPC662AIN or LPC662IN**  
**NS Package Number N08E**

## Notes

### LIFE SUPPORT POLICY

NATIONAL'S PRODUCTS ARE NOT AUTHORIZED FOR USE AS CRITICAL COMPONENTS IN LIFE SUPPORT DEVICES OR SYSTEMS WITHOUT THE EXPRESS WRITTEN APPROVAL OF THE PRESIDENT AND GENERAL COUNSEL OF NATIONAL SEMICONDUCTOR CORPORATION. As used herein:

1. Life support devices or systems are devices or systems which, (a) are intended for surgical implant into the body, or (b) support or sustain life, and whose failure to perform when properly used in accordance with instructions for use provided in the labeling, can be reasonably expected to result in a significant injury to the user.
2. A critical component is any component of a life support device or system whose failure to perform can be reasonably expected to cause the failure of the life support device or system, or to affect its safety or effectiveness.



**National Semiconductor Corporation**  
Americas  
Tel: 1-800-272-9959  
Fax: 1-800-737-7018  
Email: support@nsc.com  
www.national.com

**National Semiconductor Europe**  
Fax: +49 (0) 180-530 85 86  
Email: europe.support@nsc.com  
Deutsch Tel: +49 (0) 69 9508 6208  
English Tel: +44 (0) 870 24 0 2171  
Français Tel: +33 (0) 1 41 91 8790

**National Semiconductor Asia Pacific Customer Response Group**  
Tel: 65-2544466  
Fax: 65-2504466  
Email: ap.support@nsc.com

**National Semiconductor Japan Ltd.**  
Tel: 81-3-5639-7560  
Fax: 81-3-5639-7507

## IMPORTANT NOTICE

Texas Instruments Incorporated and its subsidiaries (TI) reserve the right to make corrections, modifications, enhancements, improvements, and other changes to its products and services at any time and to discontinue any product or service without notice. Customers should obtain the latest relevant information before placing orders and should verify that such information is current and complete. All products are sold subject to TI's terms and conditions of sale supplied at the time of order acknowledgment.

TI warrants performance of its hardware products to the specifications applicable at the time of sale in accordance with TI's standard warranty. Testing and other quality control techniques are used to the extent TI deems necessary to support this warranty. Except where mandated by government requirements, testing of all parameters of each product is not necessarily performed.

TI assumes no liability for applications assistance or customer product design. Customers are responsible for their products and applications using TI components. To minimize the risks associated with customer products and applications, customers should provide adequate design and operating safeguards.

TI does not warrant or represent that any license, either express or implied, is granted under any TI patent right, copyright, mask work right, or other TI intellectual property right relating to any combination, machine, or process in which TI products or services are used. Information published by TI regarding third-party products or services does not constitute a license from TI to use such products or services or a warranty or endorsement thereof. Use of such information may require a license from a third party under the patents or other intellectual property of the third party, or a license from TI under the patents or other intellectual property of TI.

Reproduction of TI information in TI data books or data sheets is permissible only if reproduction is without alteration and is accompanied by all associated warranties, conditions, limitations, and notices. Reproduction of this information with alteration is an unfair and deceptive business practice. TI is not responsible or liable for such altered documentation. Information of third parties may be subject to additional restrictions.

Resale of TI products or services with statements different from or beyond the parameters stated by TI for that product or service voids all express and any implied warranties for the associated TI product or service and is an unfair and deceptive business practice. TI is not responsible or liable for any such statements.

TI products are not authorized for use in safety-critical applications (such as life support) where a failure of the TI product would reasonably be expected to cause severe personal injury or death, unless officers of the parties have executed an agreement specifically governing such use. Buyers represent that they have all necessary expertise in the safety and regulatory ramifications of their applications, and acknowledge and agree that they are solely responsible for all legal, regulatory and safety-related requirements concerning their products and any use of TI products in such safety-critical applications, notwithstanding any applications-related information or support that may be provided by TI. Further, Buyers must fully indemnify TI and its representatives against any damages arising out of the use of TI products in such safety-critical applications.

TI products are neither designed nor intended for use in military/aerospace applications or environments unless the TI products are specifically designated by TI as military-grade or "enhanced plastic." Only products designated by TI as military-grade meet military specifications. Buyers acknowledge and agree that any such use of TI products which TI has not designated as military-grade is solely at the Buyer's risk, and that they are solely responsible for compliance with all legal and regulatory requirements in connection with such use.

TI products are neither designed nor intended for use in automotive applications or environments unless the specific TI products are designated by TI as compliant with ISO/TS 16949 requirements. Buyers acknowledge and agree that, if they use any non-designated products in automotive applications, TI will not be responsible for any failure to meet such requirements.

Following are URLs where you can obtain information on other Texas Instruments products and application solutions:

### Products

Audio	<a href="http://www.ti.com/audio">www.ti.com/audio</a>
Amplifiers	<a href="http://amplifier.ti.com">amplifier.ti.com</a>
Data Converters	<a href="http://dataconverter.ti.com">dataconverter.ti.com</a>
DLP® Products	<a href="http://www.dlp.com">www.dlp.com</a>
DSP	<a href="http://dsp.ti.com">dsp.ti.com</a>
Clocks and Timers	<a href="http://www.ti.com/clocks">www.ti.com/clocks</a>
Interface	<a href="http://interface.ti.com">interface.ti.com</a>
Logic	<a href="http://logic.ti.com">logic.ti.com</a>
Power Mgmt	<a href="http://power.ti.com">power.ti.com</a>
Microcontrollers	<a href="http://microcontroller.ti.com">microcontroller.ti.com</a>
RFID	<a href="http://www.ti-rfid.com">www.ti-rfid.com</a>
OMAP Mobile Processors	<a href="http://www.ti.com/omap">www.ti.com/omap</a>
Wireless Connectivity	<a href="http://www.ti.com/wirelessconnectivity">www.ti.com/wirelessconnectivity</a>

### Applications

Communications and Telecom	<a href="http://www.ti.com/communications">www.ti.com/communications</a>
Computers and Peripherals	<a href="http://www.ti.com/computers">www.ti.com/computers</a>
Consumer Electronics	<a href="http://www.ti.com/consumer-apps">www.ti.com/consumer-apps</a>
Energy and Lighting	<a href="http://www.ti.com/energy">www.ti.com/energy</a>
Industrial	<a href="http://www.ti.com/industrial">www.ti.com/industrial</a>
Medical	<a href="http://www.ti.com/medical">www.ti.com/medical</a>
Security	<a href="http://www.ti.com/security">www.ti.com/security</a>
Space, Avionics and Defense	<a href="http://www.ti.com/space-avionics-defense">www.ti.com/space-avionics-defense</a>
Transportation and Automotive	<a href="http://www.ti.com/automotive">www.ti.com/automotive</a>
Video and Imaging	<a href="http://www.ti.com/video">www.ti.com/video</a>

TI E2E Community Home Page

[e2e.ti.com](http://e2e.ti.com)

Mailing Address: Texas Instruments, Post Office Box 655303, Dallas, Texas 75265  
Copyright © 2011, Texas Instruments Incorporated