

# MAX3222 3-V to 5.5-V Multichannel RS-232 Line Driver and Receiver With $\pm 15$ -kV ESD Protection

## 1 Features

- RS-232 Bus-Pin ESD Protection Exceeds  $\pm 15$  kV Using Human-Body Model (HBM)
- Meets or Exceeds the Requirements of TIA/EIA-232-F and ITU v.28 Standards
- Operates With 3-V to 5.5-V  $V_{CC}$  Supply
- Operates Up to 250 kbps
- Two Drivers and Two Receivers
- Low Standby Current: 1  $\mu$ A Typical
- External Capacitors: 4  $\times$  0.1  $\mu$ F
- Accepts 5-V Logic Input With 3.3-V Supply
- Alternative High-Speed Pin-Compatible Device (1 Mbps)
  - SNx5C3222

## 2 Applications

- Battery-Powered Systems
- PDAs
- Notebooks
- Laptops
- Palmtop PCs
- Hand-held Equipment

## 3 Description

The MAX3222 consists of two line drivers, two line receivers, and a dual charge-pump circuit with  $\pm 15$ -kV ESD protection pin to pin (serial-port connection pins, including GND). The device meets the requirements of TIA/EIA-232-F and provides the electrical interface between an asynchronous communication controller and the serial-port connector. The charge pump and four small external capacitors allow operation from a single 3-V to 5.5-V supply. The device operates at data signaling rates up to 250 kbit/s and a maximum of 30-V/ $\mu$ s driver output slew rate.

The MAX3222 can be placed in the power-down mode by setting PWRDOWN low, which draws only 1  $\mu$ A from the power supply. When the device is powered down, the receivers remain active while the drivers are placed in the high-impedance state. Receiver outputs also can be placed in the high-impedance state by setting EN high.

### Device Information<sup>(1)</sup>

PART NUMBER	PACKAGE	BODY SIZE (NOM)
MAX3222CDW, MAX3222IDW	SOIC (20)	12.80 mm $\times$ 7.50 mm
MAX3222CDB, MAX3222IDB	SSOP (20)	7.20 mm $\times$ 5.30 mm
MAX3222CPW, MAX3222IPW	TSSOP (20)	6.50 mm $\times$ 4.40 mm

(1) For all available packages, see the orderable addendum at the end of the data sheet.

### Block Diagram

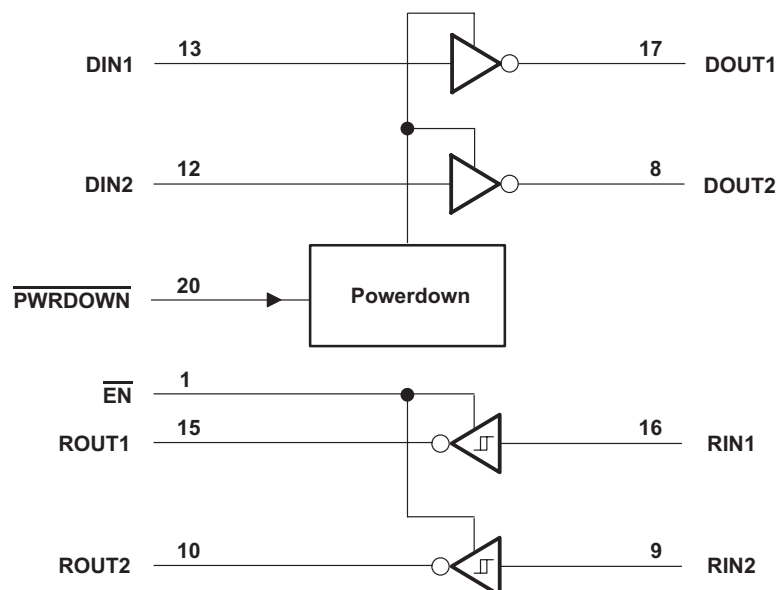

## Table of Contents

<b>1 Features</b> .....	<b>1</b>	8.1 Overview .....	<b>10</b>
<b>2 Applications</b> .....	<b>1</b>	8.2 Functional Block Diagram .....	<b>10</b>
<b>3 Description</b> .....	<b>1</b>	8.3 Feature Description .....	<b>11</b>
<b>4 Revision History</b> .....	<b>2</b>	8.4 Device Functional Modes .....	<b>11</b>
<b>5 Pin Configuration and Functions</b> .....	<b>3</b>	<b>9 Application and Implementation</b> .....	<b>12</b>
<b>6 Specifications</b> .....	<b>4</b>	9.1 Application Information .....	<b>12</b>
6.1 Absolute Maximum Ratings .....	<b>4</b>	9.2 Typical Application .....	<b>12</b>
6.2 ESD Ratings .....	<b>4</b>	<b>10 Power Supply Recommendations</b> .....	<b>13</b>
6.3 Recommended Operating Conditions .....	<b>4</b>	<b>11 Layout</b> .....	<b>13</b>
6.4 Thermal Information .....	<b>5</b>	11.1 Layout Guidelines .....	<b>13</b>
6.5 Electrical Characteristics: Device .....	<b>5</b>	11.2 Layout Example .....	<b>14</b>
6.6 Electrical Characteristics: Driver .....	<b>5</b>	<b>12 Device and Documentation Support</b> .....	<b>15</b>
6.7 Electrical Characteristics: Receiver .....	<b>6</b>	12.1 Receiving Notification of Documentation Updates .....	<b>15</b>
6.8 Switching Characteristics: Driver .....	<b>6</b>	12.2 Community Resources .....	<b>15</b>
6.9 Switching Characteristics: Receiver .....	<b>6</b>	12.3 Trademarks .....	<b>15</b>
6.10 Typical Characteristics .....	<b>7</b>	12.4 Electrostatic Discharge Caution .....	<b>15</b>
<b>7 Parameter Measurement Information</b> .....	<b>8</b>	12.5 Glossary .....	<b>15</b>
<b>8 Detailed Description</b> .....	<b>10</b>	<b>13 Mechanical, Packaging, and Orderable Information</b> .....	<b>15</b>

## 4 Revision History

NOTE: Page numbers for previous revisions may differ from page numbers in the current version.

### Changes from Revision G (March 2004) to Revision H

Page

• Added <i>ESD Ratings</i> table, <i>Feature Description</i> section, <i>Device Functional Modes</i> , <i>Application and Implementation</i> section, <i>Power Supply Recommendations</i> section, <i>Layout</i> section, <i>Device and Documentation Support</i> section, and <i>Mechanical, Packaging, and Orderable Information</i> section. ....	<b>1</b>
• Deleted <i>ORDERING INFORMATION</i> table; see POA at the end of the datasheet. ....	<b>3</b>
• Changed $R_{\theta JA}$ for DB, DW and PW package from: 70 °C/W to 84.4°C/W (DB), 58 °C/W to 70.2 °C/W (DW) and 83 °C/W to 94.3 °C/W (PW) in the <i>Thermal Information</i> table. ....	<b>5</b>

## 5 Pin Configuration and Functions

DB, DW, or PW Package  
20-Pin SOIC, SSOP, TSSOP  
Top View

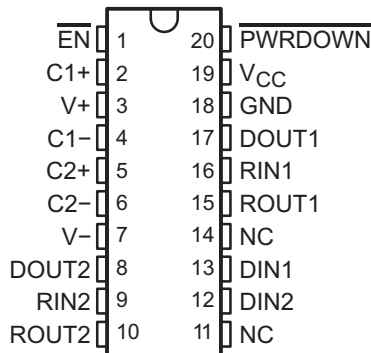

NC – No internal connection

### Pin Functions

PIN		I/O	DESCRIPTION
NAME	NO.		
C1+	2	—	Charge pump capacitor pin
C1-	4	—	Charge pump capacitor pin
C2+	5	—	Charge pump capacitor pin
C2-	6	—	Charge pump capacitor pin
DIN1	13	I	Driver logic input
DIN2	12	I	Driver logic input
DOUT1	17	O	RS-232 driver output
DOUT2	8	O	RS-232 driver output
$\overline{\text{EN}}$	1	I	Receiver enable, active low
GND	18	—	Ground
NC	11,14	—	No internal connection
$\overline{\text{PWRDOWN}}$	20	I	Driver disable, active low
RIN1	16	I	RS-232 receiver input
RIN2	9	I	RS-232 receiver input
ROUT1	15	O	Receiver logic output
ROUT2	10	O	Receiver logic output
V <sub>CC</sub>	19	—	Power Supply
V+	3	—	Charge pump capacitor pin
V-	7	—	Charge pump capacitor pin

## 6 Specifications

### 6.1 Absolute Maximum Ratings

 over operating free-air temperature range (unless otherwise noted)<sup>(1)</sup>

		MIN	MAX	UNIT
Supply voltage, $V_{CC}$ <sup>(2)</sup>		-0.3	6	V
Positive output supply voltage, $V_+$ <sup>(2)</sup>		-0.3	7	V
Negative output supply voltage, $V_-$ <sup>(2)</sup>		0.3	-7	V
Supply voltage difference, $V_+ - V_-$			13	V
Input voltage, $V_I$	Drivers, $\overline{EN}$ , $\overline{PWRDOWN}$	-0.3	6	V
	Receiver	-25	25	
Output voltage, $V_O$	Drivers	-13.2	13.2	V
	Receivers	-0.3	$V_{CC} + 0.3$	
Operating virtual junction temperature, $T_J$			150	°C
Storage temperature, $T_{stg}$		-65	150	°C

- (1) Stresses beyond those listed under *Absolute Maximum Ratings* may cause permanent damage to the device. These are stress ratings only, which do not imply functional operation of the device at these or any other conditions beyond those indicated under *Recommended Operating Conditions*. Exposure to absolute-maximum-rated conditions for extended periods may affect device reliability.
- (2) All voltages are with respect to network GND.

### 6.2 ESD Ratings

			VALUE	UNIT
$V_{(ESD)}$ Electrostatic discharge	Human-body model (HBM), per ANSI/ESDA/JEDEC JS-001 RIN, DOUT, and GND pins <sup>(1)</sup>	Pins 8, 9, 16, 17 and 18	±15000	V
		All other pins	±3000	
	Charged-device model (CDM), per JEDEC specification JESD22-C101 <sup>(2)</sup>	All pins	±1500	

- (1) JEDEC document JEP155 states that 500-V HBM allows safe manufacturing with a standard ESD control process.
- (2) JEDEC document JEP157 states that 250-V CDM allows safe manufacturing with a standard ESD control process.

### 6.3 Recommended Operating Conditions

 over operating free-air temperature range (unless otherwise noted)<sup>(1)</sup>. See [Figure 8](#).

		MIN NOM MAX			UNIT	
Supply voltage		$V_{CC} = 3.3\text{ V}$	3	3.3	3.6	V
		$V_{CC} = 5\text{ V}$	4.5	5	5.5	
$V_{IH}$	Driver and control high-level input voltage	$DIR, \overline{EN}, \overline{PWRDOWN}$	$V_{CC} = 3.3\text{ V}$	2		V
			$V_{CC} = 5\text{ V}$	2.4		
$V_{IL}$	Driver and control low-level input voltage	$DIR, \overline{EN}, \overline{PWRDOWN}$	0.8		V	
$V_I$	Driver and control input voltage	$DIR, \overline{EN}, \overline{PWRDOWN}$	0	5.5		V
$V_I$	Receiver input voltage		-25	25		V
TA	Operating free-air temperature	MAX3222C	0	70		°C
		MAX3222I	-40	85		

- (1) Test conditions are  $C1-C4 = 0.1\ \mu\text{F}$  at  $V_{CC} = 3.3\text{ V} \pm 0.3\text{ V}$ ;  $C1 = 0.047\ \mu\text{F}$ ,  $C2-C4 = 0.33\ \mu\text{F}$  at  $V_{CC} = 5\text{ V} \pm 0.5\text{ V}$ .

## 6.4 Thermal Information

THERMAL METRIC <sup>(1)(2)(3)</sup>		MAX3222			UNIT
		DB (SSOP)	DW (SOIC)	PW (TSSOP)	
		20 PINS	20 PINS	20 PINS	
R <sub>θJA</sub>	Junction-to-ambient thermal resistance	84.4	70.2	94.3	°C/W
R <sub>θJC(top)</sub>	Junction-to-case (top) thermal resistance	44.1	36.2	29.9	°C/W
R <sub>θJB</sub>	Junction-to-board thermal resistance	40	37.9	45.1	°C/W
ψ <sub>JT</sub>	Junction-to-top characterization parameter	11	11.1	1.4	°C/W
ψ <sub>JB</sub>	Junction-to-board characterization parameter	39.5	37.5	44.6	°C/W

- (1) For more information about traditional and new thermal metrics, see the [Semiconductor and IC Package Thermal Metrics](#) application report.
- (2) Maximum power dissipation is a function of T<sub>J(max)</sub>, θ<sub>JA</sub>, and T<sub>A</sub>. The maximum allowable power dissipation at any allowable ambient temperature is P<sub>D</sub> = (T<sub>J(max)</sub> - T<sub>A</sub>)/θ<sub>JA</sub>. Operating at the absolute maximum T<sub>J</sub> of 150°C can affect reliability.
- (3) The package thermal impedance is calculated in accordance with JESD 51-7.

## 6.5 Electrical Characteristics: Device

over operating free-air temperature range (unless otherwise noted)<sup>(1)</sup>. See [Figure 8](#).

PARAMETER		TEST CONDITIONS	MIN	TYP <sup>(2)</sup>	MAX	UNIT
I <sub>I</sub>	Input leakage current ( $\overline{\text{EN}}$ , $\overline{\text{PWRDOWN}}$ )			±0.01	±1	μA
I <sub>CC</sub>	Supply current	No load, $\overline{\text{PWRDOWN}}$ at V <sub>CC</sub>		0.3	1	mA
	Supply current (powered off)	No load, $\overline{\text{PWRDOWN}}$ at GND		1	10	μA

- (1) Test conditions are C1–C4 = 0.1 μF at V<sub>CC</sub> = 3.3 V ± 0.3 V; C1 = 0.047 μF, C2–C4 = 0.33 μF at V<sub>CC</sub> = 5 V ± 0.5 V.
- (2) All typical values are at V<sub>CC</sub> = 3.3 V or V<sub>CC</sub> = 5 V, and T<sub>A</sub> = 25°C.

## 6.6 Electrical Characteristics: Driver

over operating free-air temperature range (unless otherwise noted)<sup>(1)</sup>. See [Figure 8](#).

PARAMETER		TEST CONDITIONS	MIN	TYP <sup>(2)</sup>	MAX	UNIT
V <sub>OH</sub>	High-level output voltage	DOUT at R <sub>L</sub> = 3 kΩ to GND, DIN = GND	5	5.4		V
V <sub>OL</sub>	Low-level output voltage	DOUT at R <sub>L</sub> = 3 kΩ to GND, DIN = V <sub>CC</sub>	–5	–5.4		V
I <sub>IH</sub>	High-level input current	V <sub>I</sub> = V <sub>CC</sub>		±0.01	±1	μA
I <sub>IL</sub>	Low-level input current	V <sub>I</sub> at GND		±0.01	±1	μA
I <sub>OS</sub>	Short-circuit output current	V <sub>CC</sub> = 3.6 V, V <sub>O</sub> = 0 V		±35	±60	mA
		V <sub>CC</sub> = 5.5 V, V <sub>O</sub> = 0 V				
r <sub>o</sub>	Output resistance	V <sub>CC</sub> , V <sub>+</sub> , and V <sub>–</sub> = 0 V, V <sub>O</sub> = ±2 V	300	10M		Ω
I <sub>off</sub>	Output leakage current	$\overline{\text{PWRDOWN}}$ = GND, V <sub>O</sub> = ±12 V, V <sub>CC</sub> = 3 V to 3.6 V			±25	μA
		$\overline{\text{PWRDOWN}}$ = GND, V <sub>O</sub> = ±10 V, V <sub>CC</sub> = 4.5 V to 5.5 V			±25	

- (1) Test conditions are C1–C4 = 0.1 μF at V<sub>CC</sub> = 3.3 V ± 0.3 V; C1 = 0.047 μF, C2–C4 = 0.33 μF at V<sub>CC</sub> = 5 V ± 0.5 V.
- (2) All typical values are at V<sub>CC</sub> = 3.3 V or V<sub>CC</sub> = 5 V, and T<sub>A</sub> = 25°C.

## 6.7 Electrical Characteristics: Receiver

over operating free-air temperature range (unless otherwise noted)<sup>(1)</sup>. See [Figure 8](#).

PARAMETER		TEST CONDITIONS	MIN	TYP <sup>(2)</sup>	MAX	UNIT
V <sub>OH</sub>	High-level output voltage	I <sub>OH</sub> = -1 mA	V <sub>CC</sub> - 0.6	V <sub>CC</sub> - 0.1		V
V <sub>OL</sub>	Low-level output voltage	I <sub>OL</sub> = 1.6 mA			0.4	V
V <sub>IT+</sub>	Positive-going input threshold voltage	V <sub>CC</sub> = 3.3 V		1.5	2.4	V
		V <sub>CC</sub> = 5 V		1.8	2.4	
V <sub>IT-</sub>	Negative-going input threshold voltage	V <sub>CC</sub> = 3.3 V	0.6	1.2		V
		V <sub>CC</sub> = 5 V	0.8	1.5		
V <sub>hys</sub>	Input hysteresis (V <sub>IT+</sub> - V <sub>IT-</sub> )			0.3		V
I <sub>off</sub>	Output leakage current	$\overline{\text{EN}} = V_{\text{CC}}$		±0.05	±10	µA
r <sub>i</sub>	Input resistance	V <sub>i</sub> = ±3 V to ±25 V	3	5	7	kΩ

(1) Test conditions are C1–C4 = 0.1 µF at V<sub>CC</sub> = 3.3 V ± 0.3 V; C1 = 0.047 µF, C2–C4 = 0.33 µF at V<sub>CC</sub> = 5 V ± 0.5 V.

(2) All typical values are at V<sub>CC</sub> = 3.3 V or V<sub>CC</sub> = 5 V, and T<sub>A</sub> = 25°C.

## 6.8 Switching Characteristics: Driver

over operating free-air temperature range (unless otherwise noted)<sup>(1)</sup>. See [Figure 8](#).

PARAMETER		TEST CONDITIONS	MIN	TYP <sup>(2)</sup>	MAX	UNIT
	Maximum data rate	C <sub>L</sub> = 1000 pF, R <sub>L</sub> = 3 kΩ, One DOUT switching, see <a href="#">Figure 3</a>	150	250		kbps
t <sub>sk(p)</sub>	Pulse skew <sup>(3)</sup>	C <sub>L</sub> = 150 pF to 2500 pF, R <sub>L</sub> = 3 kΩ to 7 kΩ, see <a href="#">Figure 4</a>		300		ns
SR(tr)	Slew rate, transition region (see <a href="#">Figure 3</a> )	R <sub>L</sub> = 3 kΩ to 7 kΩ, V <sub>CC</sub> = 3.3 V	C <sub>L</sub> = 150 pF to 1000 pF	6	30	V/µs
			C <sub>L</sub> = 150 pF to 2500 pF	4	30	

(1) Test conditions are C1–C4 = 0.1 µF at V<sub>CC</sub> = 3.3 V ± 0.3 V; C1 = 0.047 µF, C2–C4 = 0.33 µF at V<sub>CC</sub> = 5 V ± 0.5 V.

(2) All typical values are at V<sub>CC</sub> = 3.3 V or V<sub>CC</sub> = 5 V, and T<sub>A</sub> = 25°C.

(3) Pulse skew is defined as |t<sub>PLH</sub> - t<sub>PHL</sub>| of each channel of the same device.

## 6.9 Switching Characteristics: Receiver

over operating free-air temperature range (unless otherwise noted)<sup>(1)</sup>. See [Figure 8](#).

PARAMETER		TEST CONDITIONS	MIN	TYP <sup>(2)</sup>	MAX	UNIT
t <sub>PLH</sub>	Propagation delay time, low- to high-level output	C <sub>L</sub> = 150 pF, see <a href="#">Figure 5</a>		300		ns
t <sub>PHL</sub>	Propagation delay time, high- to low-level output	C <sub>L</sub> = 150 pF, see <a href="#">Figure 5</a>		300		ns
t <sub>en</sub>	Output enable time	C <sub>L</sub> = 150 pF, R <sub>L</sub> = 3 kΩ, see <a href="#">Figure 6</a>		200		ns
t <sub>dis</sub>	Output disable time	C <sub>L</sub> = 150 pF, R <sub>L</sub> = 3 kΩ, see <a href="#">Figure 6</a>		200		ns
t <sub>sk(p)</sub>	Pulse skew <sup>(3)</sup>	See <a href="#">Figure 5</a>		300		ns

(1) Test conditions are C1–C4 = 0.1 µF at V<sub>CC</sub> = 3.3 V ± 0.3 V; C1 = 0.047 µF, C2–C4 = 0.33 µF at V<sub>CC</sub> = 5 V ± 0.5 V.

(2) All typical values are at V<sub>CC</sub> = 3.3 V or V<sub>CC</sub> = 5 V, and T<sub>A</sub> = 25°C.

(3) Pulse skew is defined as |t<sub>PLH</sub> - t<sub>PHL</sub>| of each channel of the same device.

### 6.10 Typical Characteristics

$T_A = 25^\circ\text{C}$ ;  $V_{CC} = 3.3\text{V}$

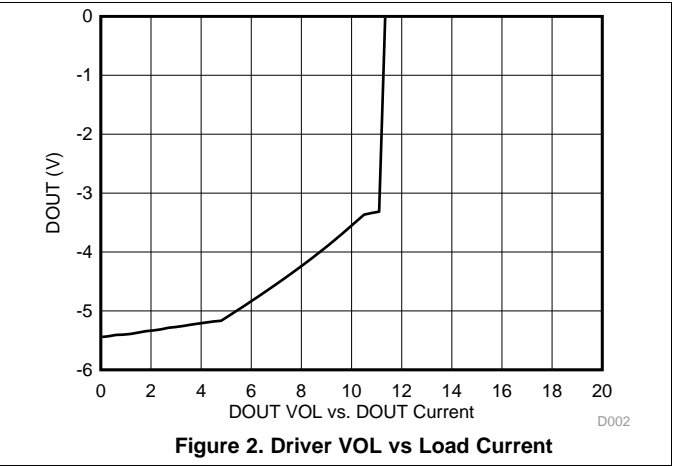
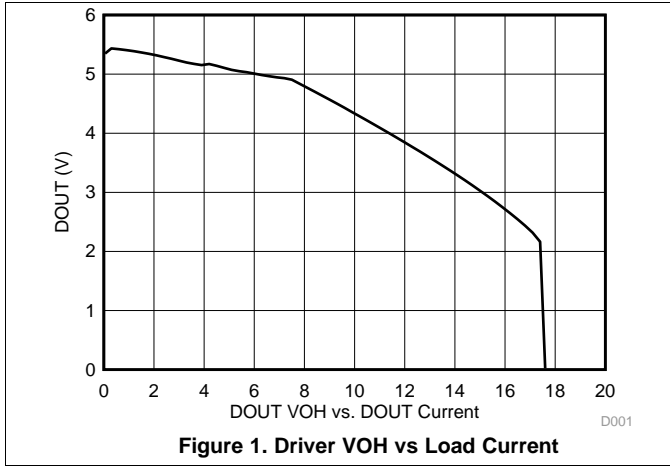

## 7 Parameter Measurement Information

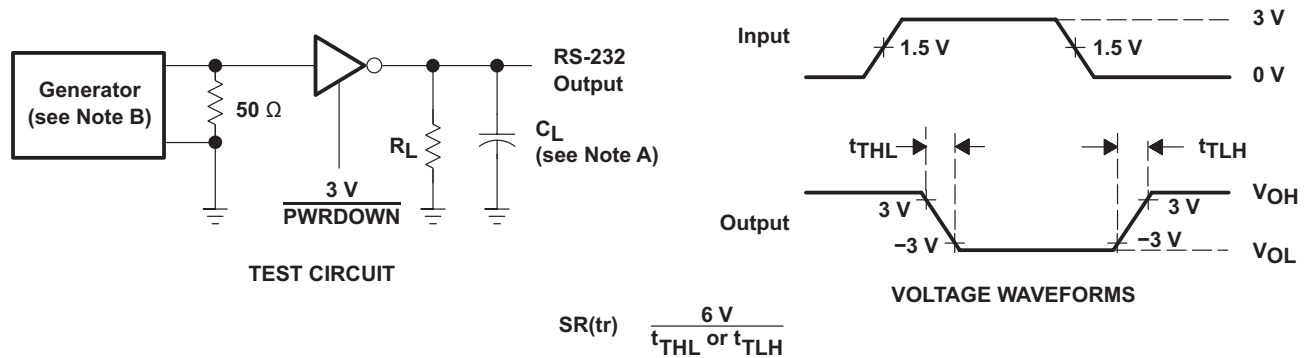

NOTES: A.  $C_L$  includes probe and jig capacitance.  
 B. The pulse generator has the following characteristics: PRR = 250 kbit/s,  $Z_O = 50 \Omega$ , 50% duty cycle,  $t_r \leq 10$  ns,  $t_f \leq 10$  ns.

**Figure 3. Driver Slew Rate**

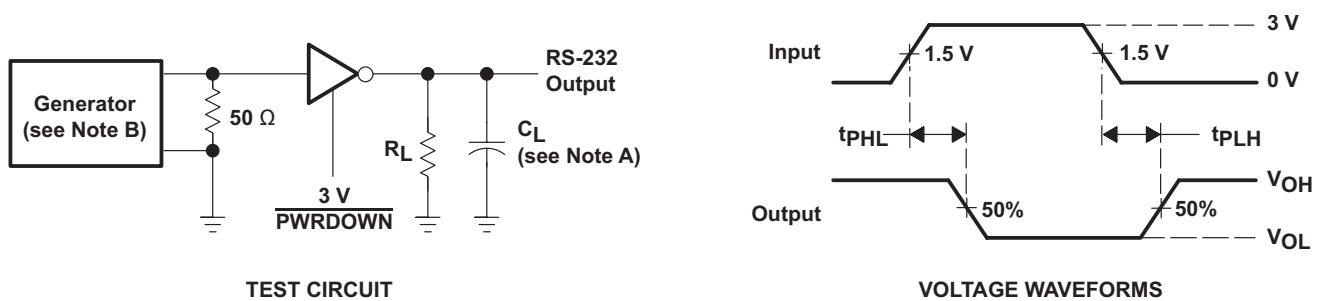

NOTES: A.  $C_L$  includes probe and jig capacitance.  
 B. The pulse generator has the following characteristics: PRR = 250 kbit/s,  $Z_O = 50 \Omega$ , 50% duty cycle,  $t_r \leq 10$  ns,  $t_f \leq 10$  ns.

**Figure 4. Driver Pulse Skew**

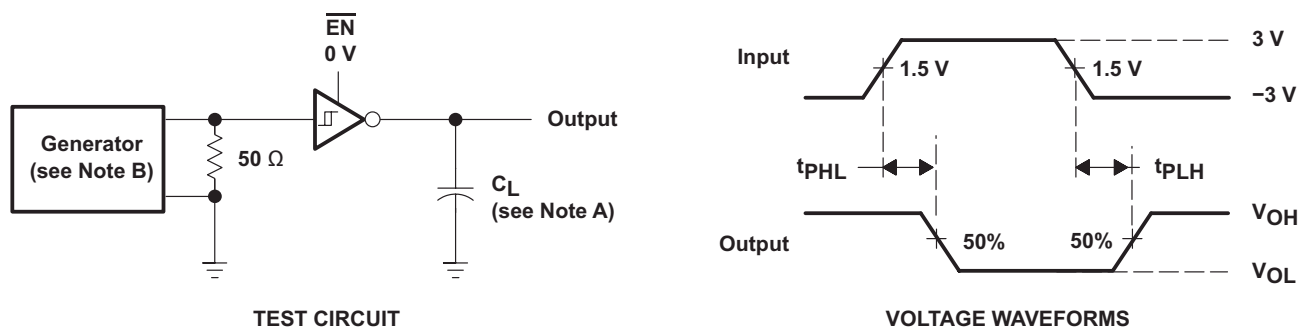

NOTES: A.  $C_L$  includes probe and jig capacitance.  
 B. The pulse generator has the following characteristics:  $Z_O = 50 \Omega$ , 50% duty cycle,  $t_r \leq 10$  ns,  $t_f \leq 10$  ns.

**Figure 5. Receiver Propagation Delay Times**

Parameter Measurement Information (continued)

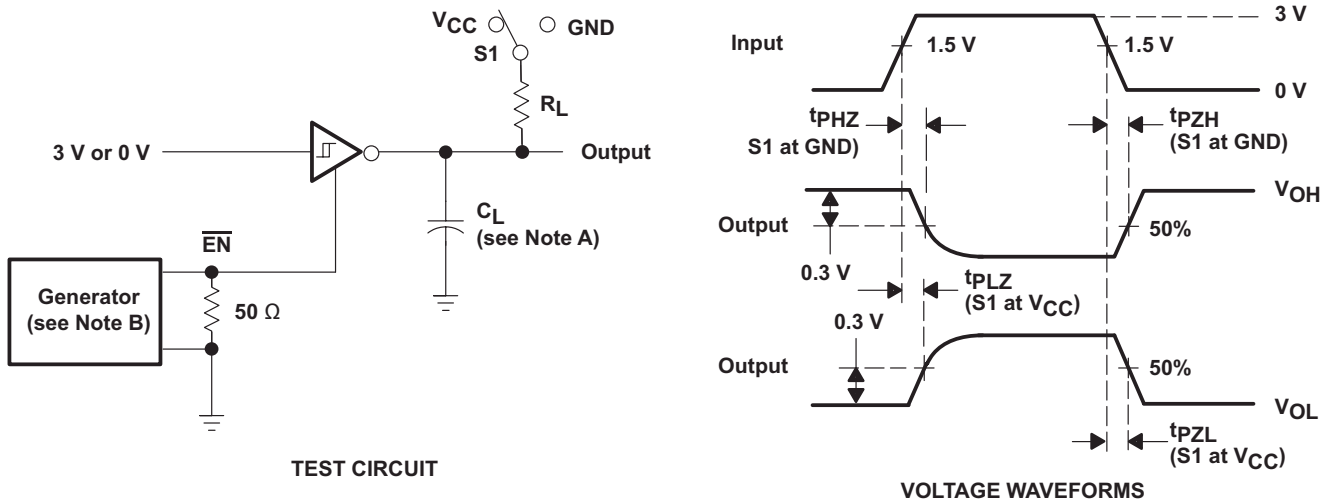

- NOTES: A.  $C_L$  includes probe and jig capacitance.  
 B. The pulse generator has the following characteristics:  $Z_O = 50 \Omega$ , 50% duty cycle,  $t_r \leq 10 \text{ ns}$ ,  $t_f \leq 10 \text{ ns}$ .

Figure 6. Receiver Enable and Disable Times

## 8 Detailed Description

### 8.1 Overview

The MAX3222 consists of two line drivers, two line receivers, and a dual charge-pump circuit with  $\pm 15$ -kV ESD protection pin to pin (serial-port connection pins, including GND). The device meets the requirements of TIA/EIA-232-F and provides the electrical interface between an asynchronous communication controller and the serial-port connector. The charge pump and four small external capacitors allow operation from a single 3-V to 5.5-V supply. The device operates at data signaling rates up to 250 kbit/s and a maximum of 30-V/ $\mu$ s driver output slew rate.

The MAX3222 can be placed in the power-down mode by setting  $\overline{\text{PWRDOWN}}$  low, which draws only 1  $\mu$ A from the power supply. When the device is powered down, the receivers remain active while the drivers are placed in the high-impedance state. Also, during power down, the onboard charge pump is disabled;  $V+$  is lowered to  $V_{CC}$ , and  $V-$  is raised toward GND. Receiver outputs also can be placed in the high-impedance state by setting EN high.

### 8.2 Functional Block Diagram

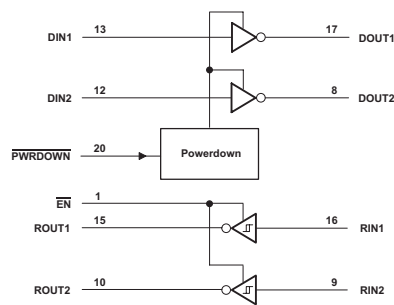

**Figure 7. Logic Diagram (Positive Logic)**

## 8.3 Feature Description

### 8.3.1 Power

The power block increases, inverts, and regulates voltage at V+ and V- pins using a charge pump that requires four external capacitors.

### 8.3.2 RS232 Driver

Two drivers interface standard logic level to RS232 levels.  $\overline{\text{PWRDOWN}}$  input low turns driver off and PWRDOWN input high turns driver on. Both DIN inputs and PWRDOWN input must be valid high or low. Do not float logic input pins.

### 8.3.3 RS232 Receiver

Two receivers interface RS232 levels to standard logic levels. An open input will result in a high output on ROUT. Each RIN input includes an internal standard RS232 load. EN input low turns on both ROUT pins. EN input high puts both ROUT pins into high impedance state, output off. EN input must be valid high or low. Do not float logic input pins.

## 8.4 Device Functional Modes

Driver and receiver outputs are controlled by the functional truth tables.

**Table 1. Functional Table - Each Driver<sup>(1)</sup>**

INPUTS		OUTPUT DOUT
DIN	$\overline{\text{PWRDOWN}}$	
X	L	Z
L	H	H
H	H	L

(1) H = high level, L = low level, X = irrelevant, Z = high impedance

**Table 2. Functional Table - Each Receiver<sup>(1)</sup>**

INPUTS		OUTPUT ROUT
RIN	$\overline{\text{EN}}$	
L	L	H
H	L	L
X	H	Z
Open	L	H

(1) H = high level, L = low level, X = irrelevant, Z = high impedance (off), Open = input disconnected or connected driver off

## 9 Application and Implementation

### NOTE

Information in the following applications sections is not part of the TI component specification, and TI does not warrant its accuracy or completeness. TI's customers are responsible for determining suitability of components for their purposes. Customers should validate and test their design implementation to confirm system functionality.

### 9.1 Application Information

The MAX3222 interfaces a universal asynchronous receiver / transmitter (UART) to RS-232 port voltage levels. External capacitors are used to generate RS-232 compliant voltages. For proper operation, add capacitors as shown in [Figure 8](#).

### 9.2 Typical Application

ROUT and DIN connect to UART or general purpose logic lines. RIN and DOUT lines connect to a RS232 connector or cable.

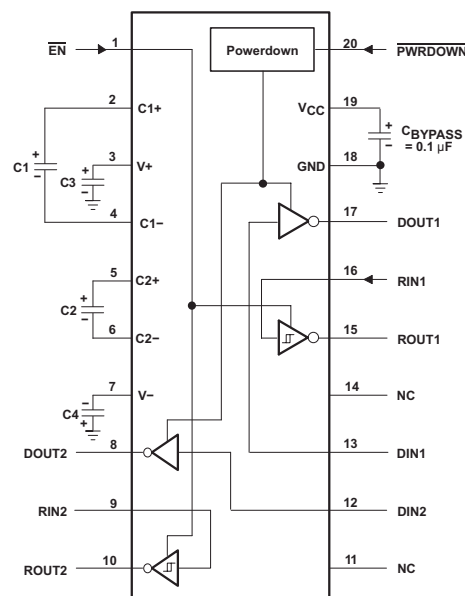

C3 can be connected to  $V_{CC}$  or GND.

Resistor values shown are nominal.

NC – No internal connection

Nonpolarized ceramic capacitors are acceptable. If polarized tantalum or electrolytic capacitors are used, they should be connected as shown.

**Figure 8. Recommended Application Schematic**

#### 9.2.1 Design Requirements

- Recommended  $V_{CC}$  is 3.3 V or 5 V. 3 V to 5.5 V is also possible
- Maximum recommended bit rate is 250 kbit/s.

**Table 3.  $V_{CC}$  vs Capacitor Values**

$V_{CC}$	C1	C2, C3, and C4
3.3 V $\pm$ 0.3 V	0.1 $\mu$ F	0.1 $\mu$ F
5 V $\pm$ 0.5 V	0.047 $\mu$ F	0.33 $\mu$ F
3 V $\pm$ 0.5 V	0.1 $\mu$ F	0.47 $\mu$ F

## 9.2.2 Detailed Design Procedure

- All  $\overline{\text{DIN}}$ ,  $\overline{\text{PWRDOWN}}$  and  $\overline{\text{EN}}$  inputs must be connected to valid low or high logic levels.
- Select capacitor values based on  $V_{CC}$  level for best performance.

## 9.2.3 Application Curves

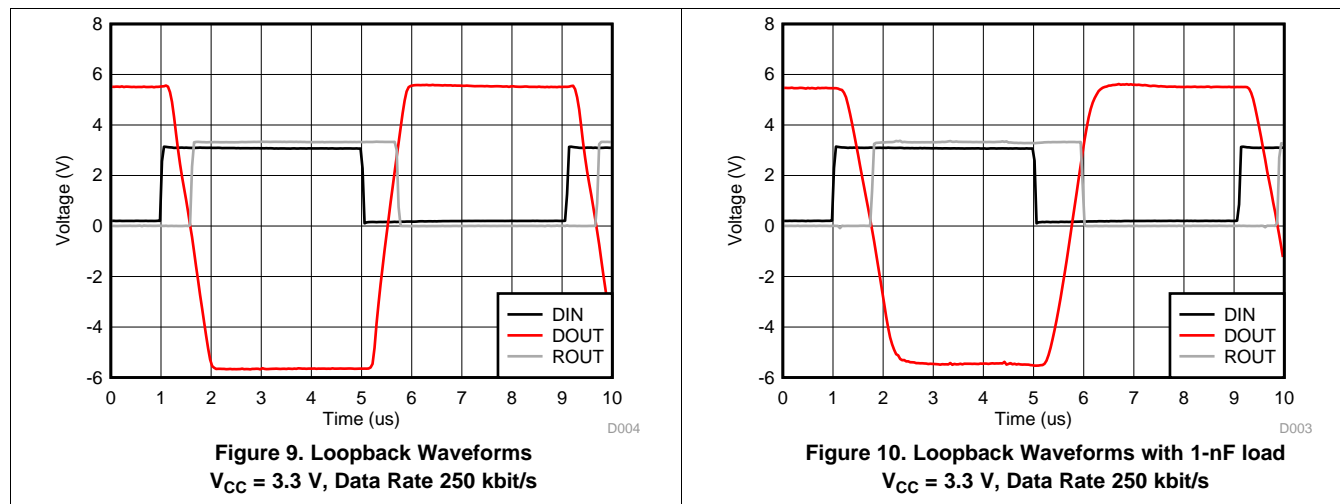

## 10 Power Supply Recommendations

$V_{CC}$  should be between 3 V and 5.5 V. Charge pump capacitors should be chosen using table in [Table 3](#).

## 11 Layout

### 11.1 Layout Guidelines

Keep the external capacitor traces short. This is more important on C1 and C2 nodes that have the fastest rise and fall times. Make the impedance from MAX3222 ground pin and circuit board's ground plane as low as possible for best ESD performance. Use wide metal and multiple vias on both sides of ground pin

## 11.2 Layout Example

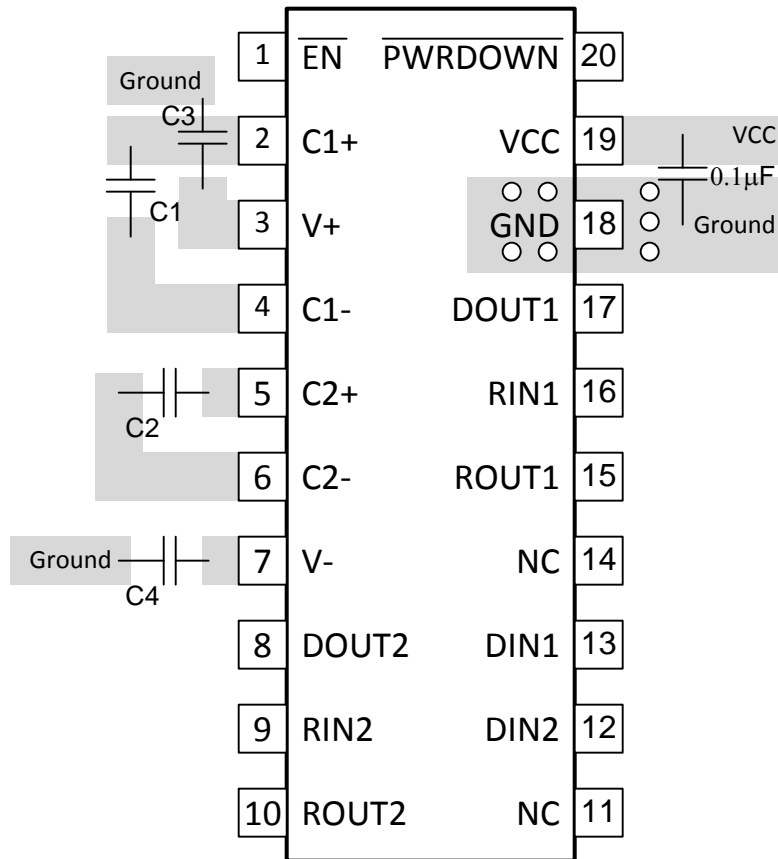

**Figure 11. MAX3222 Layout**

## 12 Device and Documentation Support

### 12.1 Receiving Notification of Documentation Updates

To receive notification of documentation updates, navigate to the device product folder on ti.com. In the upper right corner, click on *Alert me* to register and receive a weekly digest of any product information that has changed. For change details, review the revision history included in any revised document.

### 12.2 Community Resources

The following links connect to TI community resources. Linked contents are provided "AS IS" by the respective contributors. They do not constitute TI specifications and do not necessarily reflect TI's views; see TI's [Terms of Use](#).

**TI E2E™ Online Community** *TI's Engineer-to-Engineer (E2E) Community*. Created to foster collaboration among engineers. At e2e.ti.com, you can ask questions, share knowledge, explore ideas and help solve problems with fellow engineers.

**Design Support** *TI's Design Support* Quickly find helpful E2E forums along with design support tools and contact information for technical support.

### 12.3 Trademarks

E2E is a trademark of Texas Instruments.  
All other trademarks are the property of their respective owners.

### 12.4 Electrostatic Discharge Caution



These devices have limited built-in ESD protection. The leads should be shorted together or the device placed in conductive foam during storage or handling to prevent electrostatic damage to the MOS gates.

### 12.5 Glossary

[SLYZ022](#) — *TI Glossary*.

This glossary lists and explains terms, acronyms, and definitions.

## 13 Mechanical, Packaging, and Orderable Information

The following pages include mechanical, packaging, and orderable information. This information is the most current data available for the designated devices. This data is subject to change without notice and revision of this document. For browser-based versions of this data sheet, refer to the left-hand navigation.

**PACKAGING INFORMATION**

Orderable Device	Status (1)	Package Type	Package Drawing	Pins	Package Qty	Eco Plan (2)	Lead finish/ Ball material (6)	MSL Peak Temp (3)	Op Temp (°C)	Device Marking (4/5)	Samples
MAX3222CDB	ACTIVE	SSOP	DB	20	70	RoHS & Green	NIPDAU	Level-1-260C-UNLIM	0 to 70	MA3222C	<a href="#">Samples</a>
MAX3222CDBR	ACTIVE	SSOP	DB	20	2000	RoHS & Green	NIPDAU	Level-1-260C-UNLIM	0 to 70	MA3222C	<a href="#">Samples</a>
MAX3222CDBRE4	ACTIVE	SSOP	DB	20	2000	RoHS & Green	NIPDAU	Level-1-260C-UNLIM	0 to 70	MA3222C	<a href="#">Samples</a>
MAX3222CDBRG4	ACTIVE	SSOP	DB	20	2000	RoHS & Green	NIPDAU	Level-1-260C-UNLIM	0 to 70	MA3222C	<a href="#">Samples</a>
MAX3222CDW	ACTIVE	SOIC	DW	20	25	RoHS & Green	NIPDAU	Level-1-260C-UNLIM	0 to 70	MAX3222C	<a href="#">Samples</a>
MAX3222CDWR	ACTIVE	SOIC	DW	20	2000	RoHS & Green	NIPDAU	Level-1-260C-UNLIM	0 to 70	MAX3222C	<a href="#">Samples</a>
MAX3222CDWRE4	ACTIVE	SOIC	DW	20	2000	RoHS & Green	NIPDAU	Level-1-260C-UNLIM	0 to 70	MAX3222C	<a href="#">Samples</a>
MAX3222CPW	NRND	TSSOP	PW	20	70	RoHS & Green	NIPDAU	Level-1-260C-UNLIM	0 to 70	MA3222C	
MAX3222CPWR	ACTIVE	TSSOP	PW	20	2000	RoHS & Green	NIPDAU	Level-1-260C-UNLIM	0 to 70	MA3222C	<a href="#">Samples</a>
MAX3222IDB	ACTIVE	SSOP	DB	20	70	RoHS & Green	NIPDAU	Level-1-260C-UNLIM	-40 to 85	MB3222I	<a href="#">Samples</a>
MAX3222IDBR	ACTIVE	SSOP	DB	20	2000	RoHS & Green	NIPDAU	Level-1-260C-UNLIM	-40 to 85	MB3222I	<a href="#">Samples</a>
MAX3222IDBRE4	ACTIVE	SSOP	DB	20	2000	RoHS & Green	NIPDAU	Level-1-260C-UNLIM	-40 to 85	MB3222I	<a href="#">Samples</a>
MAX3222IDW	ACTIVE	SOIC	DW	20	25	RoHS & Green	NIPDAU	Level-1-260C-UNLIM	-40 to 85	MAX3222I	<a href="#">Samples</a>
MAX3222IDWG4	ACTIVE	SOIC	DW	20	25	RoHS & Green	NIPDAU	Level-1-260C-UNLIM	-40 to 85	MAX3222I	<a href="#">Samples</a>
MAX3222IDWR	ACTIVE	SOIC	DW	20	2000	RoHS & Green	NIPDAU	Level-1-260C-UNLIM	-40 to 85	MAX3222I	<a href="#">Samples</a>
MAX3222IPW	NRND	TSSOP	PW	20	70	RoHS & Green	NIPDAU	Level-1-260C-UNLIM	-40 to 85	MB3222I	
MAX3222IPWR	ACTIVE	TSSOP	PW	20	2000	RoHS & Green	NIPDAU	Level-1-260C-UNLIM	-40 to 85	MB3222I	<a href="#">Samples</a>
MAX3222IPWRE4	ACTIVE	TSSOP	PW	20	2000	RoHS & Green	NIPDAU	Level-1-260C-UNLIM	-40 to 85	MB3222I	<a href="#">Samples</a>

(1) The marketing status values are defined as follows:

**ACTIVE:** Product device recommended for new designs.

**LIFEBUY:** TI has announced that the device will be discontinued, and a lifetime-buy period is in effect.

**NRND:** Not recommended for new designs. Device is in production to support existing customers, but TI does not recommend using this part in a new design.

**PREVIEW:** Device has been announced but is not in production. Samples may or may not be available.

**OBSELETE:** TI has discontinued the production of the device.

<sup>(2)</sup> **RoHS:** TI defines "RoHS" to mean semiconductor products that are compliant with the current EU RoHS requirements for all 10 RoHS substances, including the requirement that RoHS substance do not exceed 0.1% by weight in homogeneous materials. Where designed to be soldered at high temperatures, "RoHS" products are suitable for use in specified lead-free processes. TI may reference these types of products as "Pb-Free".

**RoHS Exempt:** TI defines "RoHS Exempt" to mean products that contain lead but are compliant with EU RoHS pursuant to a specific EU RoHS exemption.

**Green:** TI defines "Green" to mean the content of Chlorine (Cl) and Bromine (Br) based flame retardants meet JS709B low halogen requirements of  $\leq 1000$ ppm threshold. Antimony trioxide based flame retardants must also meet the  $\leq 1000$ ppm threshold requirement.

<sup>(3)</sup> MSL, Peak Temp. - The Moisture Sensitivity Level rating according to the JEDEC industry standard classifications, and peak solder temperature.

<sup>(4)</sup> There may be additional marking, which relates to the logo, the lot trace code information, or the environmental category on the device.

<sup>(5)</sup> Multiple Device Markings will be inside parentheses. Only one Device Marking contained in parentheses and separated by a "~" will appear on a device. If a line is indented then it is a continuation of the previous line and the two combined represent the entire Device Marking for that device.

<sup>(6)</sup> Lead finish/Ball material - Orderable Devices may have multiple material finish options. Finish options are separated by a vertical ruled line. Lead finish/Ball material values may wrap to two lines if the finish value exceeds the maximum column width.

**Important Information and Disclaimer:** The information provided on this page represents TI's knowledge and belief as of the date that it is provided. TI bases its knowledge and belief on information provided by third parties, and makes no representation or warranty as to the accuracy of such information. Efforts are underway to better integrate information from third parties. TI has taken and continues to take reasonable steps to provide representative and accurate information but may not have conducted destructive testing or chemical analysis on incoming materials and chemicals. TI and TI suppliers consider certain information to be proprietary, and thus CAS numbers and other limited information may not be available for release.

In no event shall TI's liability arising out of such information exceed the total purchase price of the TI part(s) at issue in this document sold by TI to Customer on an annual basis.

**TAPE AND REEL INFORMATION**

**QUADRANT ASSIGNMENTS FOR PIN 1 ORIENTATION IN TAPE**



\*All dimensions are nominal

Device	Package Type	Package Drawing	Pins	SPQ	Reel Diameter (mm)	Reel Width W1 (mm)	A0 (mm)	B0 (mm)	K0 (mm)	P1 (mm)	W (mm)	Pin1 Quadrant
MAX3222CDBR	SSOP	DB	20	2000	330.0	16.4	8.2	7.5	2.5	12.0	16.0	Q1
MAX3222CDWR	SOIC	DW	20	2000	330.0	24.4	10.8	13.3	2.7	12.0	24.0	Q1
MAX3222CPWR	TSSOP	PW	20	2000	330.0	16.4	6.95	7.1	1.6	8.0	16.0	Q1
MAX3222CPWR	TSSOP	PW	20	2000	330.0	16.4	6.95	7.0	1.4	8.0	16.0	Q1
MAX3222IDBR	SSOP	DB	20	2000	330.0	16.4	8.2	7.5	2.5	12.0	16.0	Q1
MAX3222IDWR	SOIC	DW	20	2000	330.0	24.4	10.8	13.3	2.7	12.0	24.0	Q1
MAX3222IPWR	TSSOP	PW	20	2000	330.0	16.4	6.95	7.0	1.4	8.0	16.0	Q1

**TAPE AND REEL BOX DIMENSIONS**

\*All dimensions are nominal

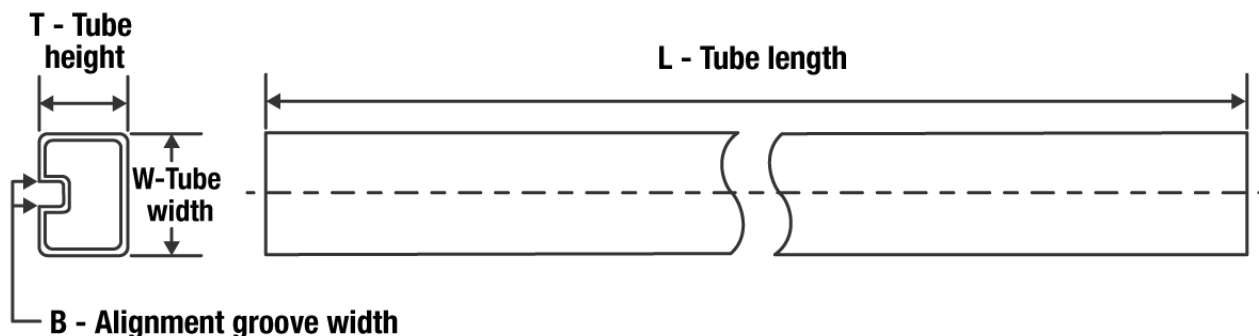
Device	Package Type	Package Drawing	Pins	SPQ	Length (mm)	Width (mm)	Height (mm)
MAX3222CDBR	SSOP	DB	20	2000	853.0	449.0	35.0
MAX3222CDWR	SOIC	DW	20	2000	367.0	367.0	45.0
MAX3222CPWR	TSSOP	PW	20	2000	853.0	449.0	35.0
MAX3222CPWR	TSSOP	PW	20	2000	853.0	449.0	35.0
MAX3222IDBR	SSOP	DB	20	2000	853.0	449.0	35.0
MAX3222IDWR	SOIC	DW	20	2000	367.0	367.0	45.0
MAX3222IPWR	TSSOP	PW	20	2000	853.0	449.0	35.0

**TUBE**

\*All dimensions are nominal

Device	Package Name	Package Type	Pins	SPQ	L (mm)	W (mm)	T (μm)	B (mm)
MAX3222CDB	DB	SSOP	20	70	530	10.5	4000	4.1
MAX3222CDW	DW	SOIC	20	25	507	12.83	5080	6.6
MAX3222CPW	PW	TSSOP	20	70	530	10.2	3600	3.5
MAX3222IDB	DB	SSOP	20	70	530	10.5	4000	4.1
MAX3222IDW	DW	SOIC	20	25	507	12.83	5080	6.6
MAX3222IDWG4	DW	SOIC	20	25	507	12.83	5080	6.6
MAX3222IPW	PW	TSSOP	20	70	530	10.2	3600	3.5

# PW0020A



# PACKAGE OUTLINE

## TSSOP - 1.2 mm max height

SMALL OUTLINE PACKAGE



4220206/A 02/2017

### NOTES:

1. All linear dimensions are in millimeters. Any dimensions in parenthesis are for reference only. Dimensioning and tolerancing per ASME Y14.5M.
2. This drawing is subject to change without notice.
3. This dimension does not include mold flash, protrusions, or gate burrs. Mold flash, protrusions, or gate burrs shall not exceed 0.15 mm per side.
4. This dimension does not include interlead flash. Interlead flash shall not exceed 0.25 mm per side.
5. Reference JEDEC registration MO-153.

# EXAMPLE BOARD LAYOUT

PW0020A

TSSOP - 1.2 mm max height

SMALL OUTLINE PACKAGE



LAND PATTERN EXAMPLE  
EXPOSED METAL SHOWN  
SCALE: 10X



SOLDER MASK DETAILS

4220206/A 02/2017

NOTES: (continued)

6. Publication IPC-7351 may have alternate designs.
7. Solder mask tolerances between and around signal pads can vary based on board fabrication site.

# EXAMPLE STENCIL DESIGN

PW0020A

TSSOP - 1.2 mm max height

SMALL OUTLINE PACKAGE



SOLDER PASTE EXAMPLE  
BASED ON 0.125 mm THICK STENCIL  
SCALE: 10X

4220206/A 02/2017

NOTES: (continued)

8. Laser cutting apertures with trapezoidal walls and rounded corners may offer better paste release. IPC-7525 may have alternate design recommendations.
9. Board assembly site may have different recommendations for stencil design.

PW (R-PDSO-G20)

PLASTIC SMALL OUTLINE



- NOTES:
- A. All linear dimensions are in millimeters.
  - B. This drawing is subject to change without notice.
  - C. Publication IPC-7351 is recommended for alternate design.
  - D. Laser cutting apertures with trapezoidal walls and also rounding corners will offer better paste release. Customers should contact their board assembly site for stencil design recommendations. Refer to IPC-7525 for other stencil recommendations.
  - E. Customers should contact their board fabrication site for solder mask tolerances between and around signal pads.

# DB0020A



# PACKAGE OUTLINE

## SSOP - 2 mm max height

SMALL OUTLINE PACKAGE



4214851/B 08/2019

### NOTES:

1. All linear dimensions are in millimeters. Any dimensions in parenthesis are for reference only. Dimensioning and tolerancing per ASME Y14.5M.
2. This drawing is subject to change without notice.
3. This dimension does not include mold flash, protrusions, or gate burrs. Mold flash, protrusions, or gate burrs shall not exceed 0.15 mm per side.
4. This dimension does not include interlead flash. Interlead flash shall not exceed 0.25 mm per side.
5. Reference JEDEC registration MO-150.

# EXAMPLE BOARD LAYOUT

DB0020A

SSOP - 2 mm max height

SMALL OUTLINE PACKAGE



LAND PATTERN EXAMPLE  
EXPOSED METAL SHOWN  
SCALE: 10X



4214851/B 08/2019

NOTES: (continued)

- Publication IPC-7351 may have alternate designs.
- Solder mask tolerances between and around signal pads can vary based on board fabrication site.

# EXAMPLE STENCIL DESIGN

DB0020A

SSOP - 2 mm max height

SMALL OUTLINE PACKAGE



SOLDER PASTE EXAMPLE  
BASED ON 0.125 mm THICK STENCIL  
SCALE: 10X

4214851/B 08/2019

NOTES: (continued)

8. Laser cutting apertures with trapezoidal walls and rounded corners may offer better paste release. IPC-7525 may have alternate design recommendations.
9. Board assembly site may have different recommendations for stencil design.

# DW0020A



# PACKAGE OUTLINE

## SOIC - 2.65 mm max height

SOIC



### NOTES:

1. All linear dimensions are in millimeters. Dimensions in parenthesis are for reference only. Dimensioning and tolerancing per ASME Y14.5M.
2. This drawing is subject to change without notice.
3. This dimension does not include mold flash, protrusions, or gate burrs. Mold flash, protrusions, or gate burrs shall not exceed 0.15 mm per side.
4. This dimension does not include interlead flash. Interlead flash shall not exceed 0.43 mm per side.
5. Reference JEDEC registration MS-013.

# EXAMPLE BOARD LAYOUT

DW0020A

SOIC - 2.65 mm max height

SOIC



LAND PATTERN EXAMPLE  
SCALE:6X



SOLDER MASK DETAILS

4220724/A 05/2016

NOTES: (continued)

- 6. Publication IPC-7351 may have alternate designs.
- 7. Solder mask tolerances between and around signal pads can vary based on board fabrication site.

# EXAMPLE STENCIL DESIGN

DW0020A

SOIC - 2.65 mm max height

SOIC



SOLDER PASTE EXAMPLE  
BASED ON 0.125 mm THICK STENCIL  
SCALE:6X

4220724/A 05/2016

NOTES: (continued)

8. Laser cutting apertures with trapezoidal walls and rounded corners may offer better paste release. IPC-7525 may have alternate design recommendations.
9. Board assembly site may have different recommendations for stencil design.

## IMPORTANT NOTICE AND DISCLAIMER

TI PROVIDES TECHNICAL AND RELIABILITY DATA (INCLUDING DATA SHEETS), DESIGN RESOURCES (INCLUDING REFERENCE DESIGNS), APPLICATION OR OTHER DESIGN ADVICE, WEB TOOLS, SAFETY INFORMATION, AND OTHER RESOURCES "AS IS" AND WITH ALL FAULTS, AND DISCLAIMS ALL WARRANTIES, EXPRESS AND IMPLIED, INCLUDING WITHOUT LIMITATION ANY IMPLIED WARRANTIES OF MERCHANTABILITY, FITNESS FOR A PARTICULAR PURPOSE OR NON-INFRINGEMENT OF THIRD PARTY INTELLECTUAL PROPERTY RIGHTS.

These resources are intended for skilled developers designing with TI products. You are solely responsible for (1) selecting the appropriate TI products for your application, (2) designing, validating and testing your application, and (3) ensuring your application meets applicable standards, and any other safety, security, regulatory or other requirements.

These resources are subject to change without notice. TI grants you permission to use these resources only for development of an application that uses the TI products described in the resource. Other reproduction and display of these resources is prohibited. No license is granted to any other TI intellectual property right or to any third party intellectual property right. TI disclaims responsibility for, and you will fully indemnify TI and its representatives against, any claims, damages, costs, losses, and liabilities arising out of your use of these resources.

TI's products are provided subject to [TI's Terms of Sale](#) or other applicable terms available either on [ti.com](http://ti.com) or provided in conjunction with such TI products. TI's provision of these resources does not expand or otherwise alter TI's applicable warranties or warranty disclaimers for TI products.

TI objects to and rejects any additional or different terms you may have proposed.

Mailing Address: Texas Instruments, Post Office Box 655303, Dallas, Texas 75265  
Copyright © 2022, Texas Instruments Incorporated