

TPS3704x Quad, Triple, Dual, Single Window or Standard Voltage Supervisor

1 Features

- Designed for high performance and safety:
 - Input current (4 channels): $I_{DD} = 15 \mu\text{A}$ (maximum)
 - High threshold accuracy: $\pm 1\%$ (maximum)
 - Built-in precision hysteresis: $V_{HYS} (V_{IT} > 800 \text{ mV}) = 0.75\%$ (typical)
- Designed for a wide range of applications:
 - Quad, triple, dual, or single voltage supervisor
 - TPS37044, 3, 2, 1: 4, 3, 2, 1 - channels
 - Input voltage range, $V_{DD} = 1.7 \text{ V}$ to 6 V
 - (UV / OV) threshold accuracy: $\pm 0.1\%$ (typical)
 - Each channel can be configured independently: window, UV, or OV
 - Window tolerance: $\pm 3\%$ to $\pm 11\%$ (can be programmed asymmetrical)
 - High threshold resolution:
 - $V_{IT} \leq 0.8 \text{ V}$: 20 mV steps
 - $V_{IT} > 0.8 \text{ V}$: lower of 0.5% or 20 mV steps
 - V_{IT} threshold voltages for each individual channel can be set independently
 - Push-button monitor on all channels
 - Reset time delay (t_D): fixed time delay options
 - Options: 23-fixed time options ranging from $20 \mu\text{s}$ (minimum) to 1200 ms (maximum)
 - Temperature range: -40°C to $+125^\circ\text{C}$
- Multiple output topologies:
 - TPS3704xxxO: open-drain, active-low ($\overline{\text{RESET}}$)
 - TPS3704xxxL: push-pull, active-low ($\overline{\text{RESET}}$)
 - TPS3704xxxH: push-pull, active-high (RESET)

2 Applications

- Factory automation
- Building automation
- Medical
- Motor drives
- Grid infrastructure
- Wireless infrastructure
- Data center & enterprise computing

3 Description

The TPS3704x is a low-power precision window or standard voltage supervisor that can be configured as a quad, triple, dual, or single channel. Each channel has a threshold accuracy of $\pm 1\%$ in an 8-pin ($1.6 \text{ mm} \times 2.9 \text{ mm}$) SOT-23 package offering a small solution size. The TPS3704x includes a very accurate threshold detection, with high resolution, that is ideal for systems that operate on low-voltage supply rails and have narrow margin supply tolerances. Built-in low threshold hysteresis and a fixed reset delay (t_D options from $20 \mu\text{s}$ to 1200 ms) prevent false reset signals when monitoring multiple voltage rails.

The TPS3704x does not require any external resistors for setting the over and under voltage reset thresholds, which further optimizes overall high accuracy, cost, solution size, and improves reliability for safety systems.

Separate VDD and SENSEx pins allow monitoring of rail voltages other than VDD or can be used as a push-button input. Optional use of external resistors are supported by the SENSEx pins. Each channel on the TPS3704x can be customized to its own over and under voltage window detection with an upper and lower threshold tolerance that can be symmetric or asymmetric.

Device Information

PART NUMBER	PACKAGE ⁽¹⁾	BODY SIZE (NOM)
TPS3704x	DDF (SOT-23 8-pin)	1.6 mm × 2.9 mm

- (1) For all available packages, see the orderable addendum at the end of the data sheet.

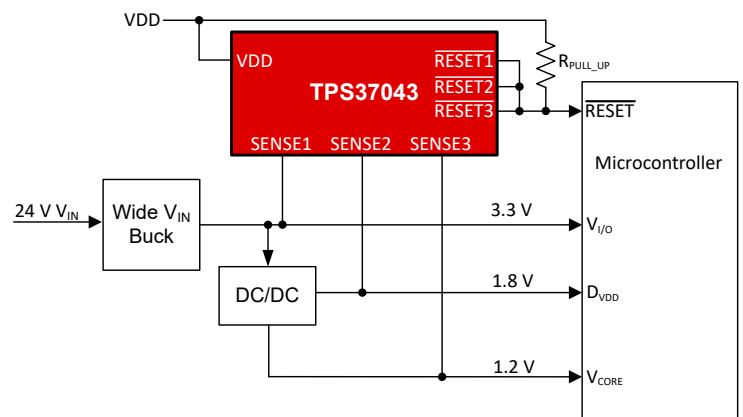

Typical Application Circuit



Table of Contents

1 Features	1	8.4 Device Functional Modes.....	19
2 Applications	1	9 Application and Implementation	20
3 Description	1	9.1 Application Information.....	20
4 Revision History	2	9.2 Typical Application.....	22
5 Device Nomenclature	3	10 Power Supply Recommendations	25
6 Pin Configuration and Functions	4	10.1 Power Supply Guidelines.....	25
7 Specifications	6	11 Layout	26
7.1 Absolute Maximum Ratings.....	6	11.1 Layout Guidelines.....	26
7.2 ESD Ratings.....	6	11.2 Layout Example.....	26
7.3 Recommended Operating Conditions.....	6	12 Device and Documentation Support	27
7.4 Thermal Information.....	7	12.1 Device Nomenclature.....	27
7.5 Electrical Characteristics.....	7	12.2 Receiving Notification of Documentation Updates.....	28
7.6 Timing Requirements.....	8	12.3 Support Resources.....	28
7.7 Timing Diagrams.....	9	12.4 Trademarks.....	28
7.8 Typical Characteristics.....	11	12.5 Electrostatic Discharge Caution.....	28
8 Detailed Description	15	12.6 Glossary.....	28
8.1 Overview.....	15	13 Mechanical, Packaging, and Orderable Information	28
8.2 Functional Block Diagram.....	15		
8.3 Feature Description.....	17		

4 Revision History

NOTE: Page numbers for previous revisions may differ from page numbers in the current version.

Changes from Revision A (July 2021) to Revision B (November 2021)	Page
• Change from Advance Information to Production Data.....	1

5 Device Nomenclature

Figure 5-1 shows the device naming nomenclature to compare the different device variants. See Table 12-1 for a more detailed explanation. See Table 12-2 for the available device variants.

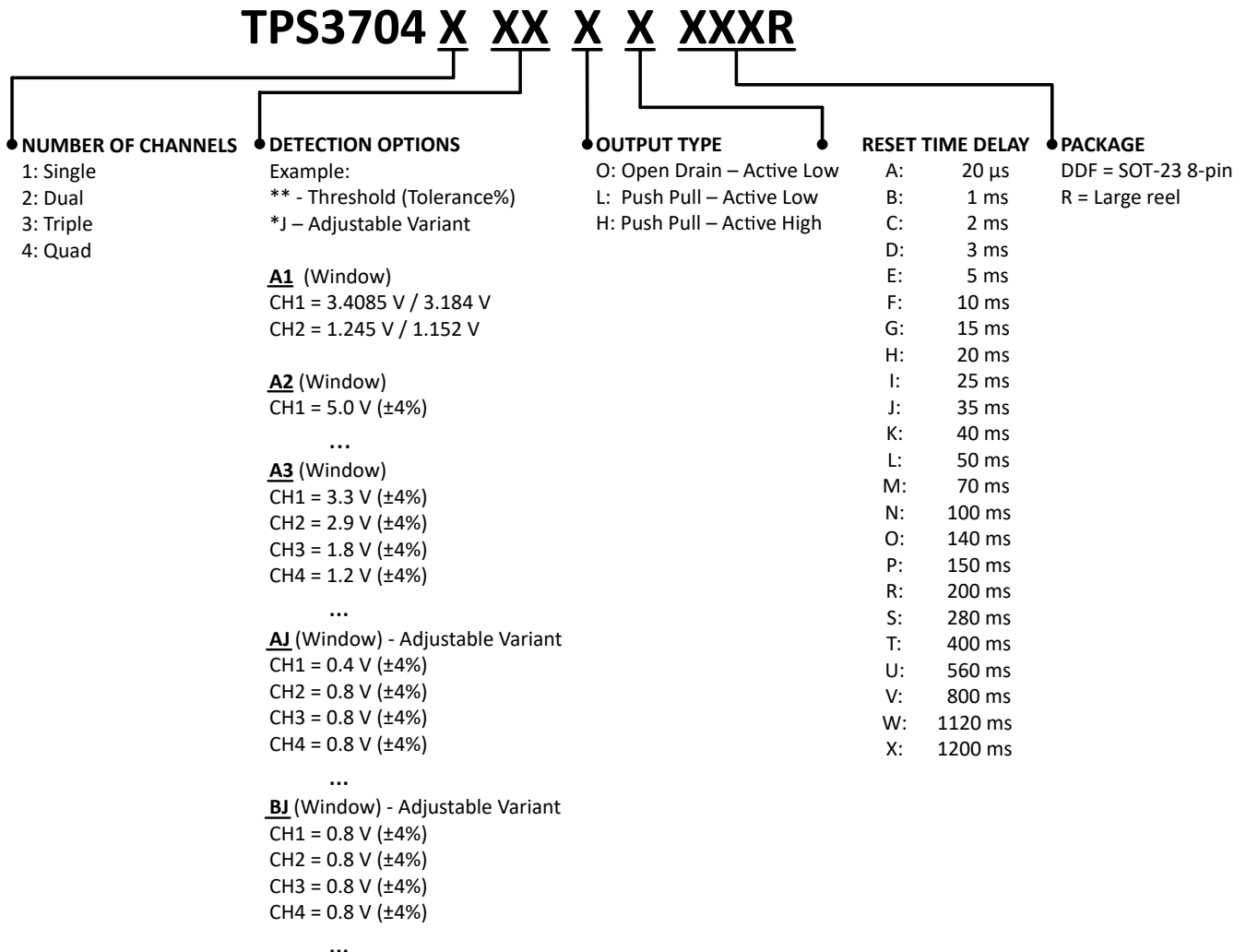
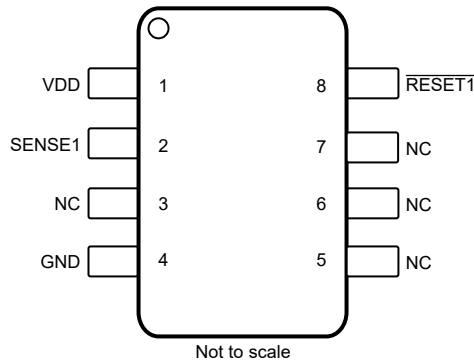
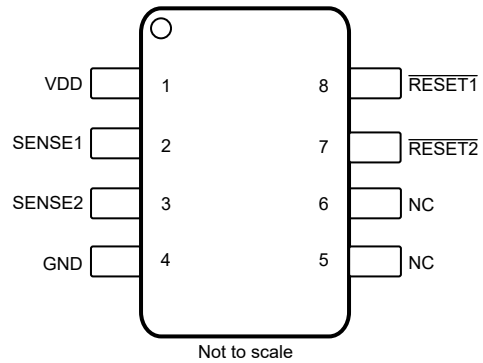

Figure 5-1. Device Naming Nomenclature

6 Pin Configuration and Functions



**Figure 6-1. SOT-23 8-PIN DDF Package
TPS37041
(Top View)**



**Figure 6-2. SOT-23 8-PIN DDF Package
TPS37042
(Top View)**

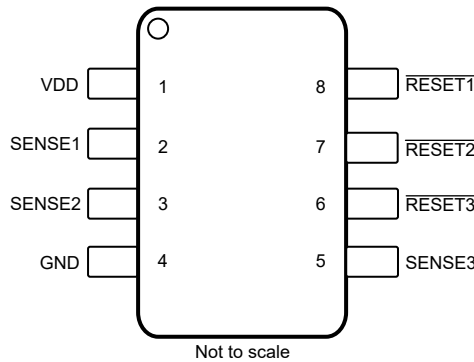

**Figure 6-3. SOT-23 8-PIN DDF Package
TPS37043
(Top View)**

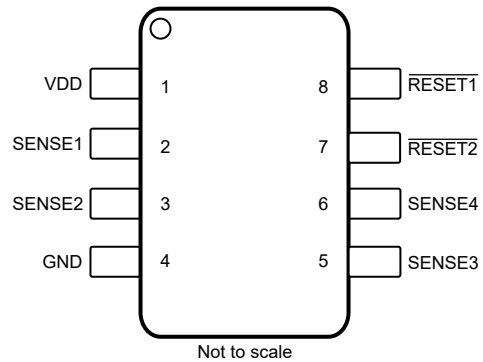

**Figure 6-4. SOT-23 8-PIN DDF Package
TPS37044
(Top View)**

Table 6-1. Pin Functions

NAME	PIN				I/O	DESCRIPTION
	TPS37041	TPS37042	TPS37043	TPS37044		
VDD	1	1	1	1	I	Supply Input. Bypass with a 0.1 μ F capacitor to GND.
SENSE1	2	2	2	2	I	Connect directly to monitored voltage. $\overline{\text{RESET1}}/\text{RESET1}$ is asserted when SENSE1 falls outside of window threshold. No external capacitor is required for this SENSE1 pin. For TPS37044 (quad version) $\overline{\text{RESET1}}/\text{RESET1}$ asserts when either SENSE1 or SENSE2 falls outside of window threshold. For noisy applications, placing a 10 nF to 100 nF ceramic capacitor close to this pin may be needed for optimum performance. If the input pin is not being used, it can be left floating.
SENSE2	-	3	3	3	I	Connect directly to monitored voltage. $\overline{\text{RESET2}}/\text{RESET2}$ is asserted when SENSE2 falls outside of window threshold. No external capacitor is required for SENSE2 pin. For TPS37044 (quad version) $\overline{\text{RESET1}}/\text{RESET1}$ asserts when either SENSE1 or SENSE2 falls outside of window threshold. For noisy applications, placing a 10 nF to 100 nF ceramic capacitor close to this pin may be needed for optimum performance. If the input pin is not being used, it can be left floating.
SENSE3	-	-	5	5	I	Connect directly to monitored voltage. $\overline{\text{RESET3}}/\text{RESET3}$ is asserted when SENSE3 falls outside of window threshold. No external capacitor is required for SENSE3 pin. For TPS37044 (quad version) $\overline{\text{RESET2}}/\text{RESET2}$ asserts when either SENSE3 or SENSE4 falls outside of window threshold. For noisy applications, placing a 10 nF to 100 nF ceramic capacitor close to this pin may be needed for optimum performance. If the input pin is not being used, it can be left floating.
SENSE4	-	-	-	6	I	Connect directly to monitored voltage. For TPS37044 (quad version) $\overline{\text{RESET2}}/\text{RESET2}$ asserts when either SENSE3 or SENSE4 falls outside of window threshold. For noisy applications, placing a 10 nF to 100 nF ceramic capacitor close to this pin may be needed for optimum performance. If the input pin is not being used, it can be left floating.
$\overline{\text{RESET1}}$ / RESET1	8	8	8	8	O	$\overline{\text{RESET1}}/\text{RESET1}$ asserts when SENSE1 falls outside of the over-voltage or under-voltage threshold window. $\overline{\text{RESET1}}/\text{RESET1}$ stays asserted for the reset timeout period after SENSE1 fall back within the window threshold. Active-low, open-drain reset output, requires an external pullup resistor. For TPS37044, $\overline{\text{RESET1}}/\text{RESET1}$ asserts when either SENSE1 or SENSE2 fall outside of the window threshold. The pin can be left floating if it is unused.
$\overline{\text{RESET2}}$ / RESET2	-	7	7	7	O	$\overline{\text{RESET2}}/\text{RESET2}$ asserts when SENSE2 falls outside of the overvoltage or undervoltage threshold window. $\overline{\text{RESET2}}/\text{RESET2}$ stays asserted for the reset timeout period after SENSE2 fall back within the window threshold. Active-low, open-drain reset output, requires an external pullup resistor. For TPS37044, $\overline{\text{RESET2}}/\text{RESET2}$ asserts when either SENSE3 or SENSE4 fall outside of the window threshold. The pin can be left floating if it is unused.
$\overline{\text{RESET3}}$ / RESET3	-	-	6	-	O	$\overline{\text{RESET3}}/\text{RESET3}$ asserts when SENSE3 falls outside of the overvoltage or undervoltage threshold window. $\overline{\text{RESET3}}/\text{RESET3}$ stays asserted for the reset timeout period after SENSE3 fall back within the window threshold. Active-low, open-drain reset output, requires an external pullup resistor. The pin can be left floating if it is unused.
GND	4	4	4	4	-	Ground
NC	3, 5, 6, 7	5, 6	-	-	-	No Connect

7 Specifications

7.1 Absolute Maximum Ratings

Over operating free-air temperature range (unless otherwise noted) ⁽¹⁾

		MIN	MAX	UNIT
Voltage	V _{DD}	-0.3	6.5	V
	V _{RESET1} , V _{RESET2} , V _{RESET3}	-0.3	6.5	V
	V _{SENSE1} , V _{SENSE2} , V _{SENSE3} , V _{SENSE4}	-0.3	6.5	V
Current	I _{RESET1} , I _{RESET2} , I _{RESET3} SINK		±20	mA
Temperature ⁽²⁾	Continuous total power dissipation	See the Thermal Information		
	Operating junction temperature, T _J	-40	150	°C
	Operating free-air temperature, T _A	-40	150	°C
	Storage temperature, T _{stg}	-65	150	°C

- (1) Stresses beyond values listed under Absolute Maximum Ratings (AMR) may cause permanent damage to the device. These are stress ratings only, which do not imply functional operation of the device at these or any other conditions beyond those indicated under Recommended Operating Conditions. Exposure to AMR-rated conditions for extended periods may affect device reliability.
- (2) As a result of the low dissipated power in this device, it is assumed that T_J = T_A.

7.2 ESD Ratings

		VALUE	UNIT
V _(ESD)	Electrostatic discharge	Human-body model (HBM), per ANSI/ESDA/ JEDEC JS-001 ⁽¹⁾	±2000
		Charged device model (CDM), per JEDEC specification JESD22-C101 ⁽²⁾	±750

- (1) JEDEC document JEP155 states that 500-V HBM allows safe manufacturing with a standard ESD control process
- (2) JEDEC document JEP157 states that 250-V CDM allows safe manufacturing with a standard ESD control process

7.3 Recommended Operating Conditions

		MIN	NOM	MAX	UNIT
V _{DD}	Supply pin voltage	1.7		6.0	V
V _{SENSE1,2,3,4}	Input pin voltage	0		6.0	V
V _{RESET1} , V _{RESET2} , V _{RESET3}	Output pin voltage	0		6.0	V
I _{RESET1} , I _{RESET2} , I _{RESET3} SINK	Output pin current sink	0.3		5	mA
T _A	Operating free air temperature	-40		125	°C

7.4 Thermal Information

THERMAL METRIC ⁽¹⁾		TPS3704x	
		DDF	UNIT
		PINS	
R _{θJA}	Junction-to-ambient thermal resistance	121.5	°C/W
R _{θJC(top)}	Junction-to-case (top) thermal resistance	60.6	°C/W
R _{θJB}	Junction-to-board thermal resistance	42.3	°C/W
Ψ _{JT}	Junction-to-top characterization parameter	2.2	°C/W
Ψ _{JB}	Junction-to-board characterization parameter	42.1	°C/W
R _{θJC(bot)}	Junction-to-case (bottom) thermal resistance	N/A	°C/W

(1) For more information about traditional and new thermal metrics, see the [Semiconductor and IC Package Thermal Metrics](#) application report.

7.5 Electrical Characteristics

At 1.7 V ≤ V_{DD} ≤ 6.0 V, RESETx Voltage (V_{RESETx}) = 10 kΩ to V_{DD}, RESETx load = 10 pF, and over the operating free-air temperature range of –40°C to 125°C, unless otherwise noted. Typical values are at T_A = 25°C, typical conditions at V_{DD} = 3.3 V.

PARAMETER		TEST CONDITIONS	MIN	TYP	MAX	UNIT
V _{DD}	Supply Voltage		1.7		6.0	V
UVLO	Under Voltage Lockout ⁽¹⁾	V _{DD} falling below 1.7 V	1.2	1.4	1.6	V
UVLO _(HYS)	UVLO Hysteresis ⁽²⁾	V _{DD} rising below 1.7 V		65		mV
V _{POR}	Power on reset voltage ⁽³⁾	V _{OL (MAX)} = 0.3 V, I _{OUT} = 15 μA			0.7	V
V _{IT} Range	Threshold Programming Range		0.4		5.55	V
V _{IT- (UV)}	UV accuracy (25°C)			0.1		%
V _{IT+ (OV)}	OV accuracy (25°C)			0.1		%
TOL_min	Tolerance Programming minimum			3		%
TOL_max	Tolerance Programming maximum			11		%
THR RES Low	Threshold Programming Resolution Low	V _{IT} ≤ 0.8 V		20		mV / step
THR RES Mid	Threshold Programming Resolution Mid	0.8 V < V _{IT} ≤ 4.0 V		0.5		% / step
THR RES High	Threshold Programming Resolution High	V _{IT} > 4.0 V		20		mV / step
V _{IT}	Accuracy for absolute threshold including tolerance	V _{IT} < 0.8 V	-1.6		1.6	%
V _{IT}	Accuracy for absolute threshold including tolerance	V _{IT} = 0.8 V - 5.55 V	-1		1	%
V _{HYS}	V _{IT} < 0.80V		1.1	1.4	1.7	%
V _{HYS}	V _{IT} ≥ 0.80V		0.40	0.75	1	%
I _{DD}	TPS3704x	V _{DD} ≤ 6.0V		5.5	15	μA
I _{SENSEX}	Input current, SENSEx pin	V _{SENSEX} = 5.5 V		1	2.5	μA
I _{SENSE_ADJ}	Input current, SENSE pin (Bypass internal resistor divider)- Adjustable version	V _{SENSEX} = 5.5 V			350	nA
V _{OL}	Low level output voltage	V _{DD} = 1.7 V, I _{SINK} = 0.4 mA			300	mV
V _{OL}	Low level output voltage	V _{DD} = 2 V, I _{SINK} = 3 mA			300	mV
V _{OL}	Low level output voltage	V _{DD} = 6.0 V, I _{SINK} = 5 mA			300	mV
I _(lkg)	Open drain output leakage current	V _{DD} = V _{RESETx} = 6.0 V			350	nA

(1) RESETx pin is driven low when V_{DD} falls below UVLO.

(2) Hysteresis is with respect of the tripoint (V_{IT- (UV)}, V_{IT+ (OV)}).

(3) V_{POR} is the minimum V_{DD} voltage level for a controlled output state. Slew rate = 100 mV / μs.

7.6 Timing Requirements

At $1.7\text{ V} \leq V_{DD} \leq 6.0\text{ V}$, $\overline{\text{RESETx}}$ voltage ($V_{\overline{\text{RESETx}}}$) = 10 k Ω to V_{DD} , $\overline{\text{RESETx}}$ load = 10 pF, and over the operating free-air temperature range of -40°C to 125°C , unless otherwise noted. Typical values are at $T_A = 25^{\circ}\text{C}$, typical conditions at $V_{DD} = 3.3\text{ V}$.

PARAMETER		TEST CONDITIONS	MIN	NOM	MAX	UNIT
t_D	Reset release time delay	Fixed delay option $t_D < 4\text{ ms}$, overdrive = 10%	-40	t_D	40	%
t_D	Reset release time delay	Fixed delay option $t_D > 5\text{ ms}$, overdrive = 10%	-30	t_D	30	%
t_{PD}	Propagation detect delay ⁽¹⁾	Fixed time delay $t_D > 1\text{ ms}$, overdrive 10%			10	μs
$t_{GI(VIT-)}$	Glitch Immunity Undervoltage (5% overdrive) ⁽²⁾			2		μs
$t_{GI(VIT+)}$	Glitch Immunity Overvoltage (5% overdrive) ⁽²⁾			2		μs
t_R	Output rise (Push-Pull) ^{(2) (3)}			25		ns
t_R	Output rise time (Open-Drain) ^{(2) (3)}			2.2		μs
t_F	Output fall time ^{(2) (3)}			0.2		μs
t_{STRT}	Startup delay ⁽⁴⁾			1		ms

- (1) t_{PD} measured from threshold trip point ($V_{IT-(UV)}$ or $V_{IT+(OV)}$) to $\overline{\text{RESETx}}$ V_{OL} voltage
- (2) 5% Overdrive from threshold. Overdrive % = $[(V_{SENSEX} - V_{IT}) / V_{IT}]$; Where V_{IT} stands for $V_{IT-(UV)}$ or $V_{IT+(OV)}$
- (3) Output transitions from V_{OL} to V_{OH} or ($V_{\overline{\text{RESETx}}}$) for rise times and V_{OH} or ($V_{\overline{\text{RESETx}}}$) to V_{OL} for fall times.
- (4) During the power-on sequence, V_{DD} must be at or above $V_{DD(MIN)}$ for at least $t_{STRT} + t_D$ before the output is in the correct state. when V_{DD} is between $V_{DD(MIN)}$ and V_{POR} the $\overline{\text{RESETx}}$ pin will be engaged

7.7 Timing Diagrams

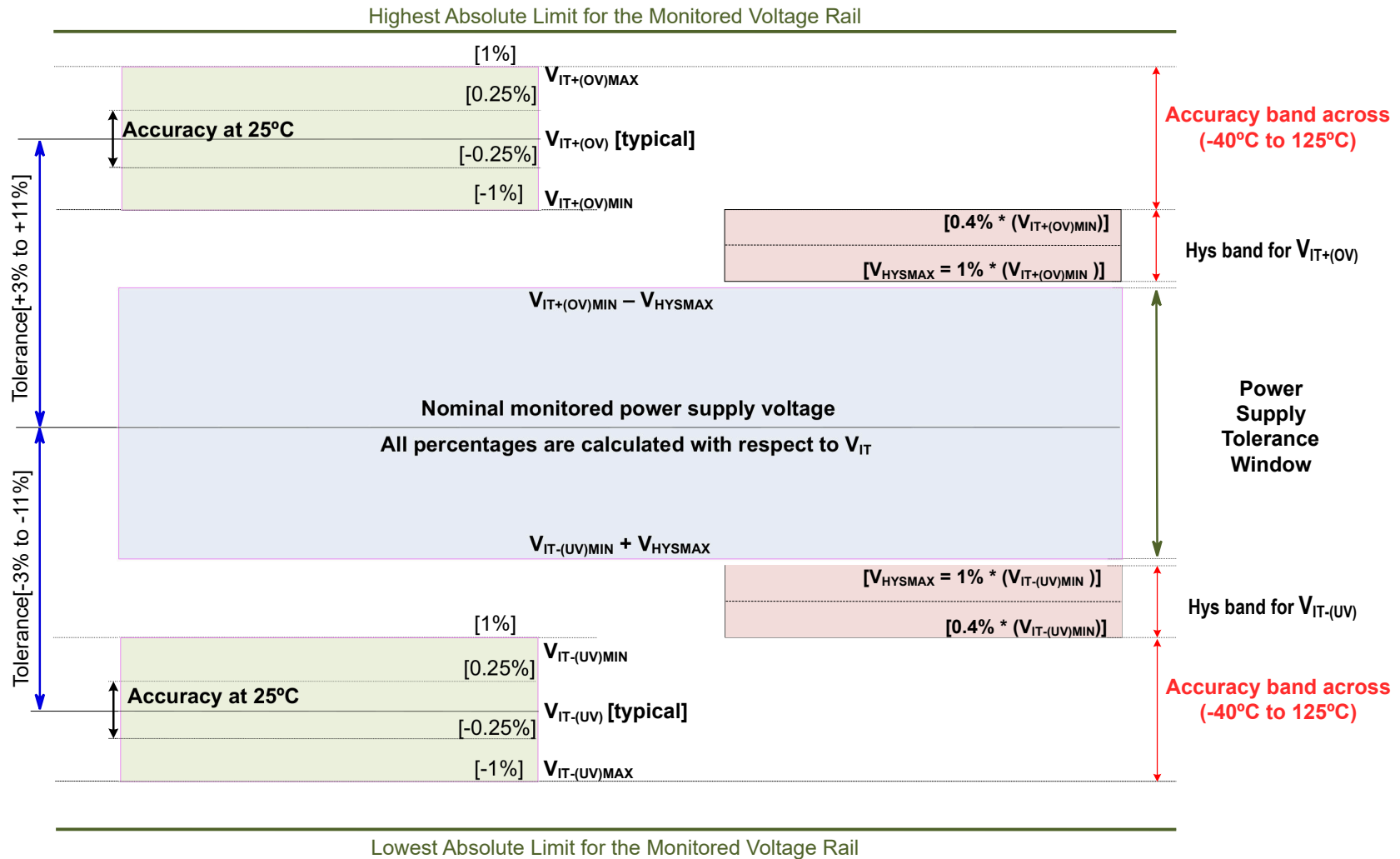
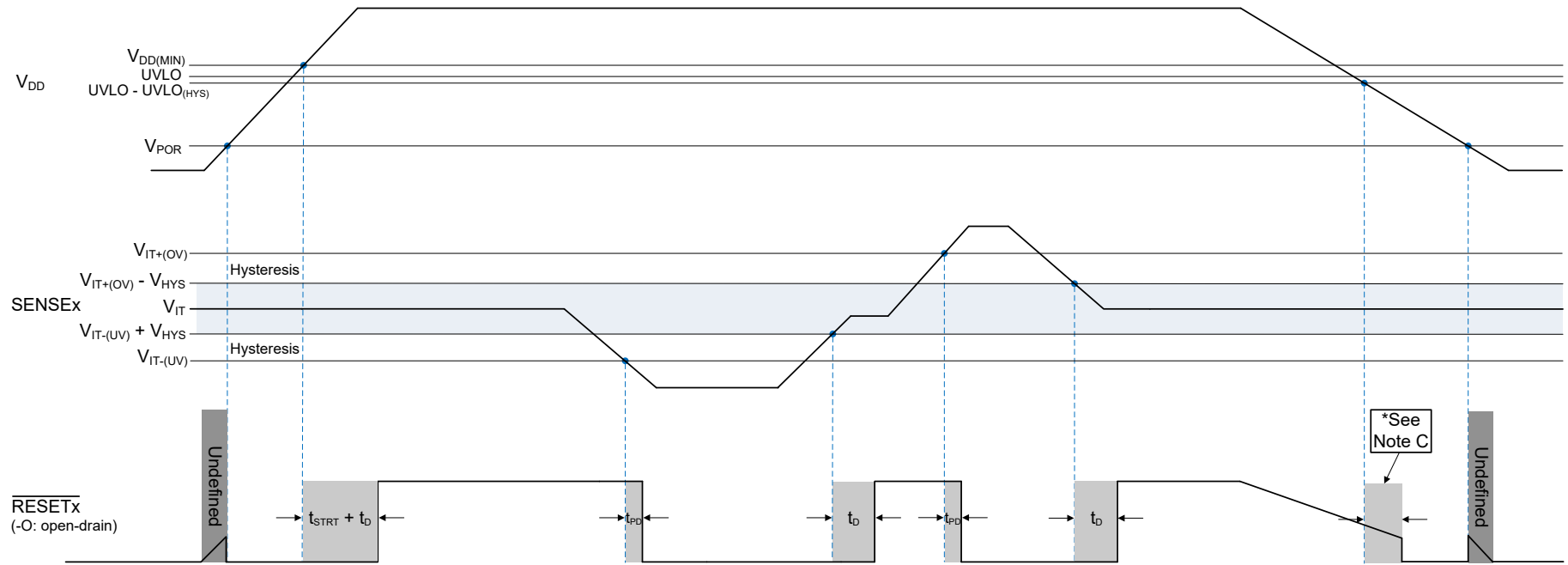

Figure 7-1. Voltage Threshold and Hysteresis Accuracy



- A. Open-Drain timing diagram assumes the $\overline{\text{RESETx}}$ / RESETx pin is connected via an external pull-up resistor to VDD.
- B. Be advised that Figure 7-2 shows the VDD falling slew rate is slow or the VDD decay time is much larger than the propagation detect delay (t_{PD}) time.
- C. $\overline{\text{RESETx}}$ /RESETx is asserted after a time delay, typical value of 100 μs , when VDD goes below the UVLO-UVLO(HYS) threshold.

Figure 7-2. SENSEx Timing Diagram

7.8 Typical Characteristics

Typical characteristics show the typical performance of the TPS3704x device. Test conditions are $T_A = 25^\circ\text{C}$, $V_{DD} = 3.3\text{ V}$, and $R_{\text{pull-up}x} = 10\text{ k}\Omega$, $C_{\text{LOAD}} = 50\text{ pF}$, unless otherwise noted.

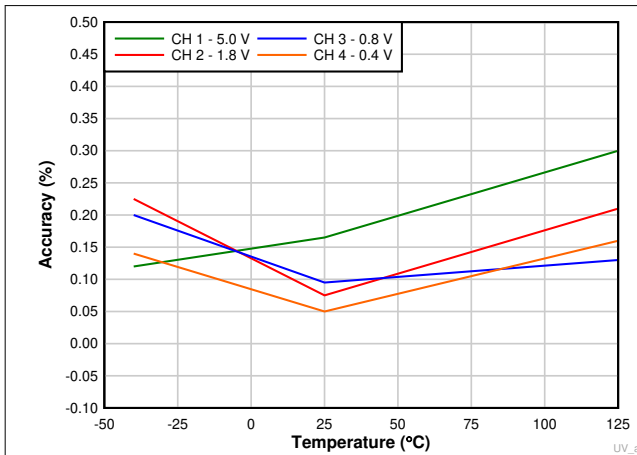

Figure 7-3. Undervoltage Accuracy vs Temperature

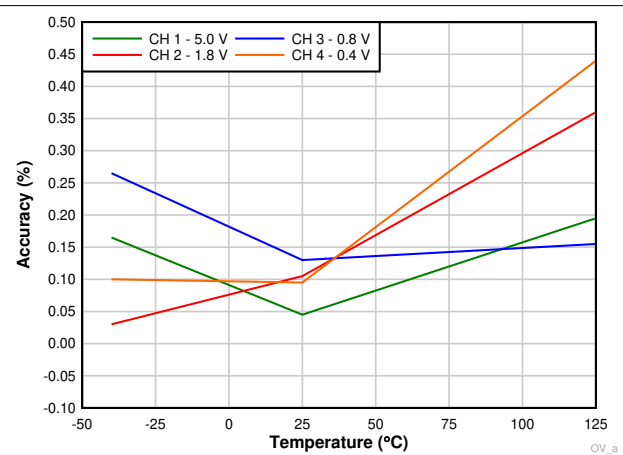

Figure 7-4. Overvoltage Accuracy vs Temperature

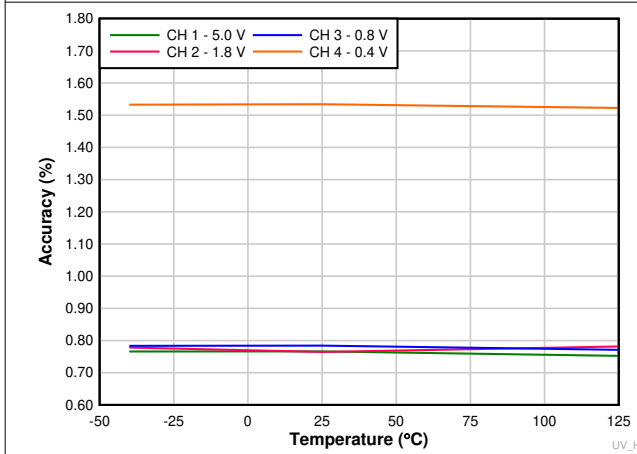

Figure 7-5. Undervoltage Hysteresis Voltage Accuracy vs Temperature

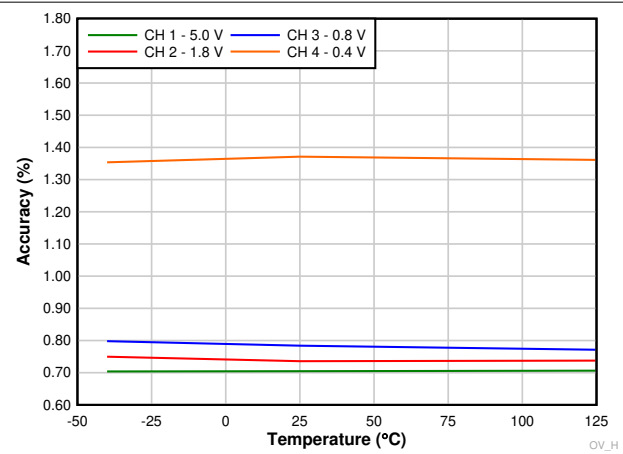

Figure 7-6. Overvoltage Hysteresis Voltage Accuracy vs Temperature

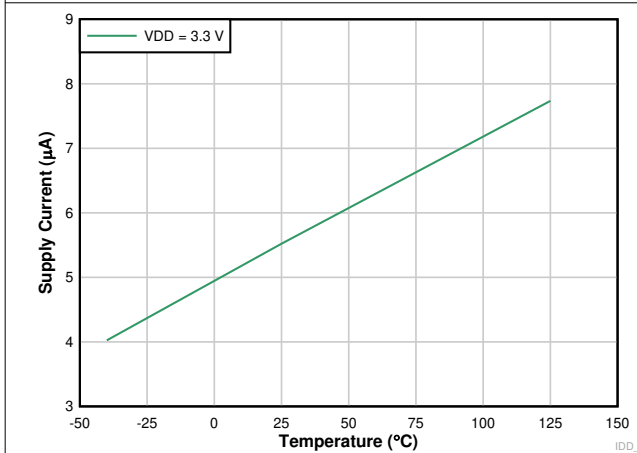

Figure 7-7. Supply Current vs Temperature
Output ($\overline{\text{RESET}}x$ Pin) = High

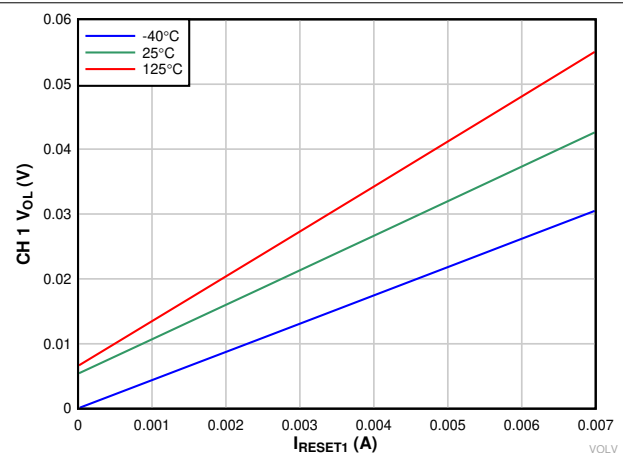

Figure 7-8. Low-Level CH 1 Output Voltage vs $\overline{\text{RESET}}1$ Current
VDD = 1.7 V

7.8 Typical Characteristics (continued)

Typical characteristics show the typical performance of the TPS3704x device. Test conditions are $T_A = 25^\circ\text{C}$, $V_{DD} = 3.3\text{ V}$, and $R_{\text{pull-up}x} = 10\text{ k}\Omega$, $C_{\text{LOAD}} = 50\text{ pF}$, unless otherwise noted.

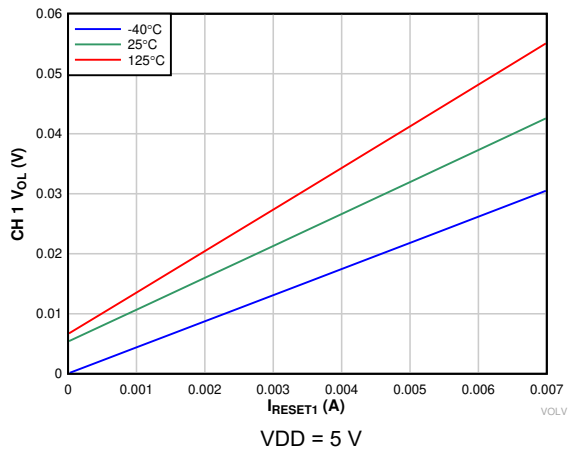

Figure 7-9. Low-Level CH 1 Output Voltage vs $\overline{\text{RESET1}}$ Current

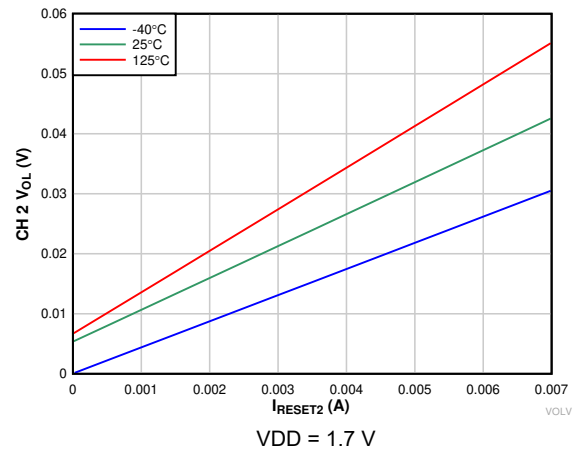

Figure 7-10. Low-Level CH 2 Output Voltage vs $\overline{\text{RESET2}}$ Current

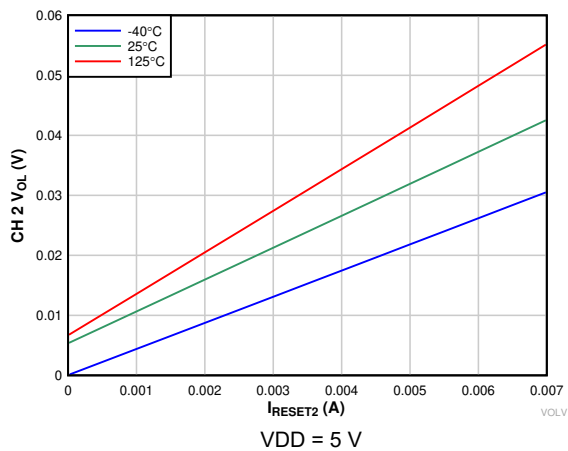

Figure 7-11. Low-Level CH 2 Output Voltage vs $\overline{\text{RESET2}}$ Current

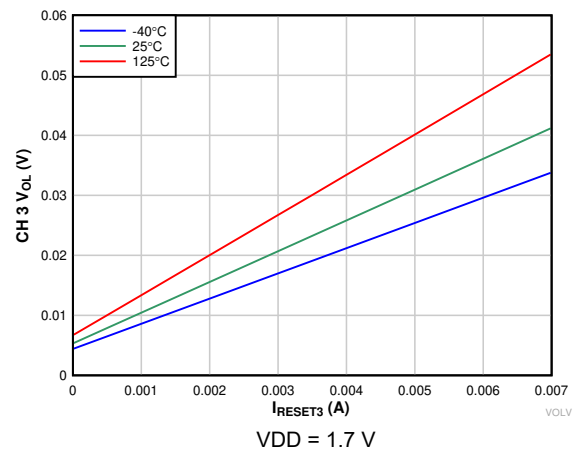

Figure 7-12. Low-Level CH 3 Output Voltage vs $\overline{\text{RESET3}}$ Current

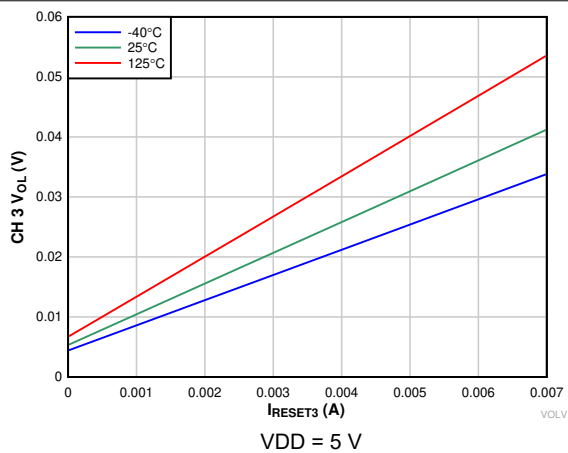

Figure 7-13. Low-Level CH 3 Output Voltage vs $\overline{\text{RESET3}}$ Current

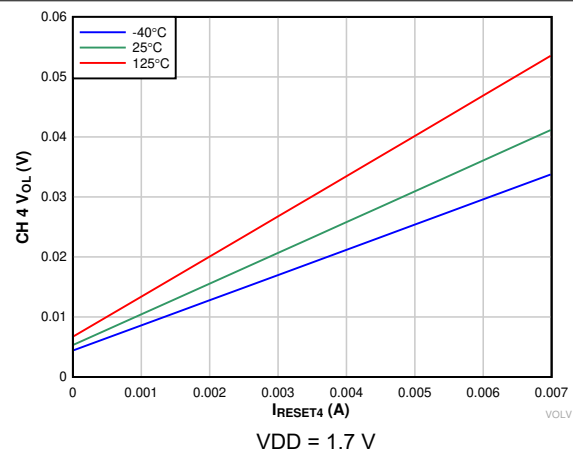

Figure 7-14. Low-Level CH 4 Output Voltage vs $\overline{\text{RESET4}}$ Current

7.8 Typical Characteristics (continued)

Typical characteristics show the typical performance of the TPS3704x device. Test conditions are $T_A = 25^\circ\text{C}$, $V_{DD} = 3.3\text{ V}$, and $R_{\text{pull-up}x} = 10\text{ k}\Omega$, $C_{\text{LOAD}} = 50\text{ pF}$, unless otherwise noted.

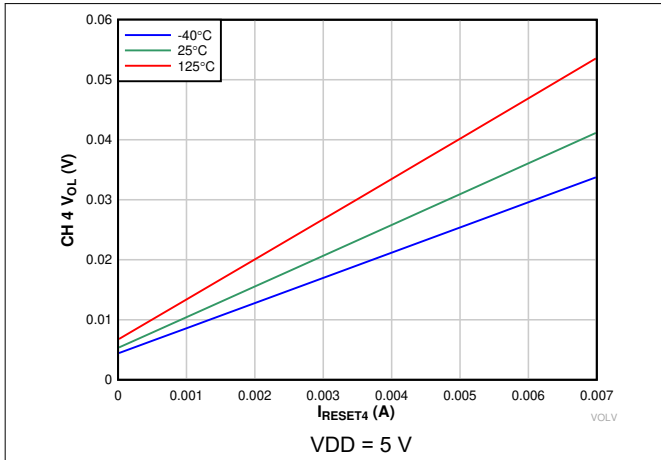

Figure 7-15. Low-Level CH 4 Output Voltage vs RESET4 Current

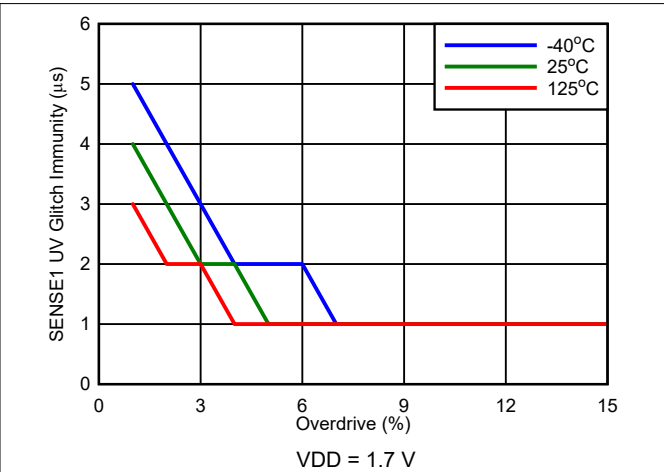

Figure 7-16. SENSE1 Glitch Immunity (V_{IT-}) vs Overdrive

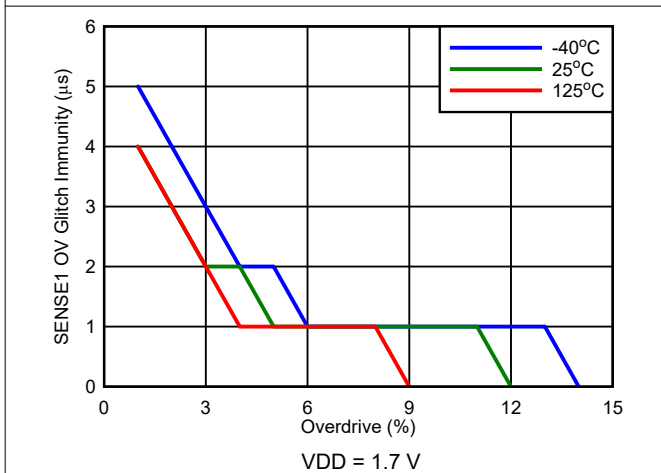

Figure 7-17. SENSE1 Glitch Immunity (V_{IT+}) vs Overdrive

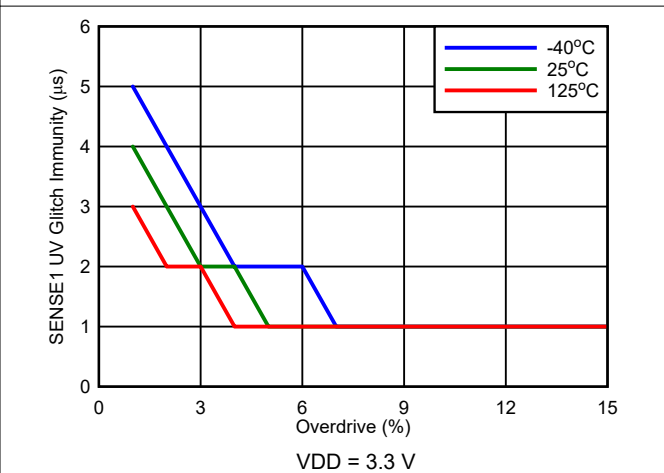

Figure 7-18. SENSE1 Glitch Immunity (V_{IT-}) vs Overdrive

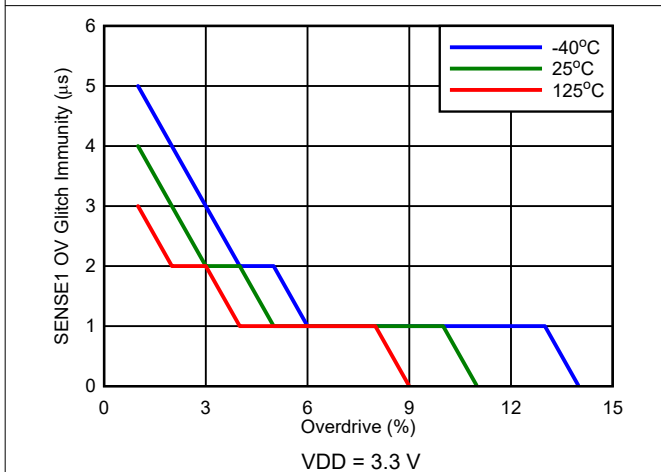

Figure 7-19. SENSE1 Glitch Immunity (V_{IT+}) vs Overdrive

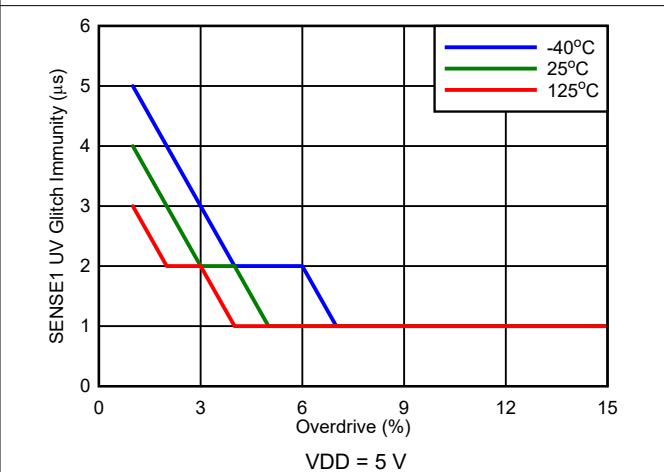

Figure 7-20. SENSE1 Glitch Immunity (V_{IT-}) vs Overdrive

7.8 Typical Characteristics (continued)

Typical characteristics show the typical performance of the TPS3704x device. Test conditions are $T_A = 25^\circ\text{C}$, $V_{DD} = 3.3\text{ V}$, and $R_{\text{pull-up}x} = 10\text{ k}\Omega$, $C_{\text{LOAD}} = 50\text{ pF}$, unless otherwise noted.

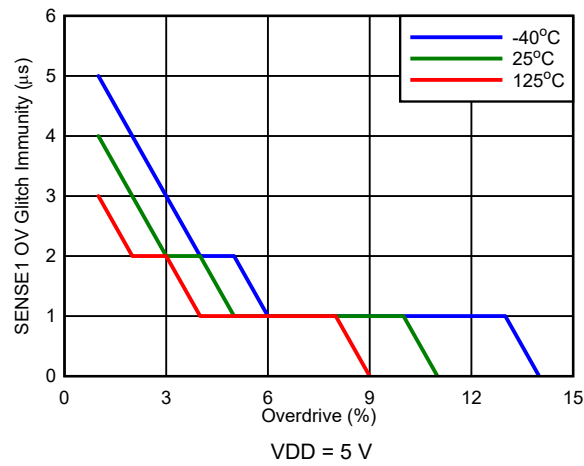

Figure 7-21. SENSE1 Glitch Immunity (V_{IT+}) vs Overdrive

8 Detailed Description

8.1 Overview

TPS3704x is a family of quad, triple, dual, and single precision voltage supervisors where each channel has overvoltage and undervoltage detection capability. The TPS3704x features a highly accurate window threshold voltage where the upper and lower thresholds can be customized for symmetric or asymmetric tolerances. The reset signal for the TPS3704x is asserted, with a fault detection time delay ($t_{PD} = 10 \mu s$ maximum), when the sense voltage is outside of the overvoltage and undervoltage thresholds.

TPS3704x includes the resistors used to set the overvoltage and undervoltage thresholds internal to the device. These internal resistors allow for lower component counts and greatly simplifies the design because no additional margins are needed to account for the accuracy of external resistors. The level of integration in the TPS3704x enables a total small solution size for any application.

The TPS3704x is capable to monitor any voltage rail with high resolution ($V_{IT} \leq 0.8 V$: 20 mV steps / $V_{IT} > 0.8 V$: 0.5% or 20 mV steps whichever is lower). Each channel in the TPS3704x can be configured independently as a window, OV or UV supervisor. Also, the V_{IT} threshold voltage for each channel can be asymmetric. For example, a channel that is configured as an overvoltage supervisor can be setup with a +5% tolerance whereas an undervoltage channel supervisor can be programmed with a -4% tolerance. If a window supervisor is configured, the voltage threshold tolerance can either be symmetrical or asymmetrical.

The TPS3704x includes fixed reset time delay (t_D) options ranging from 20 μs to 1200 ms and can monitor up to four channels while maintaining an ultra-low I_Q current of 15 μA (maximum).

8.2 Functional Block Diagram

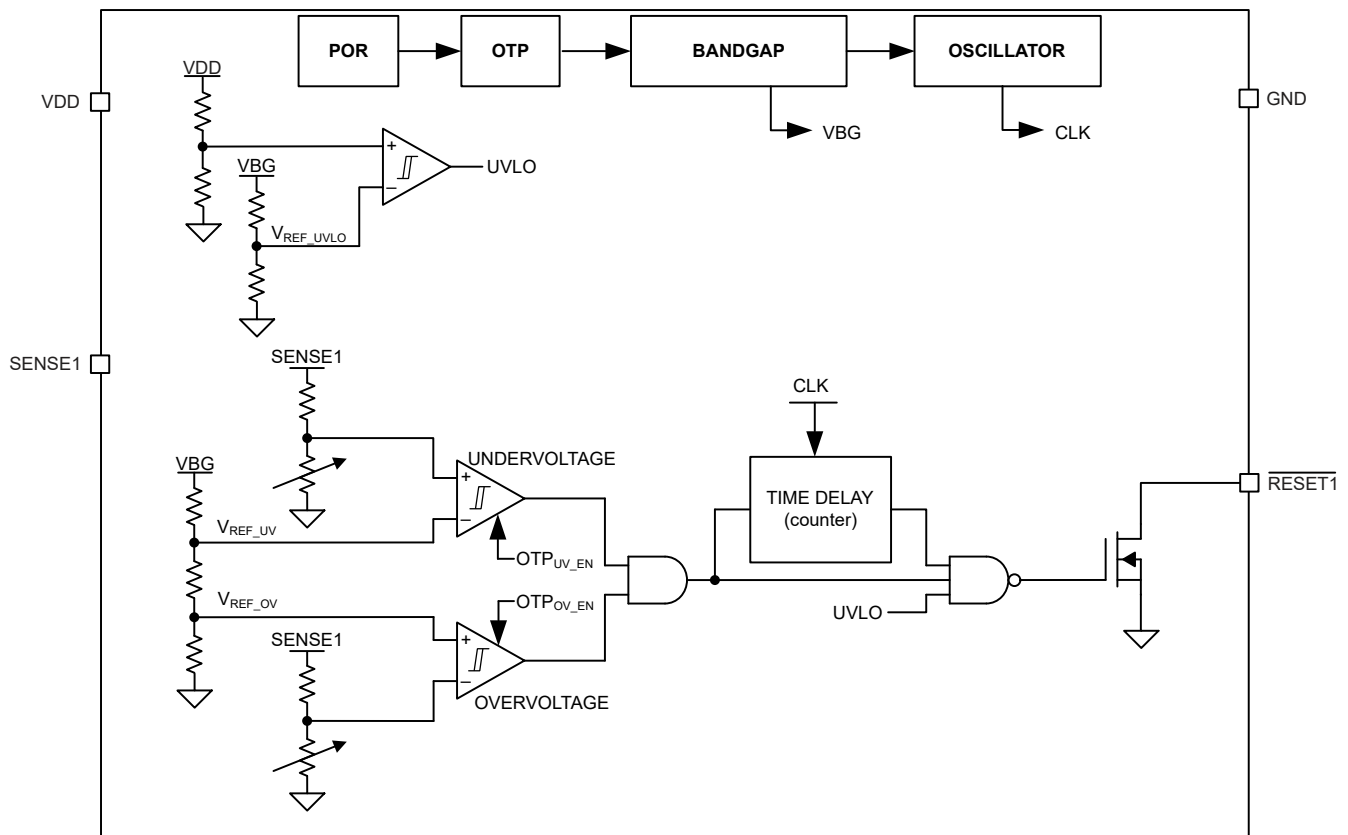

Figure 8-1. TPS37041 Single-Channel Functional Block Diagram

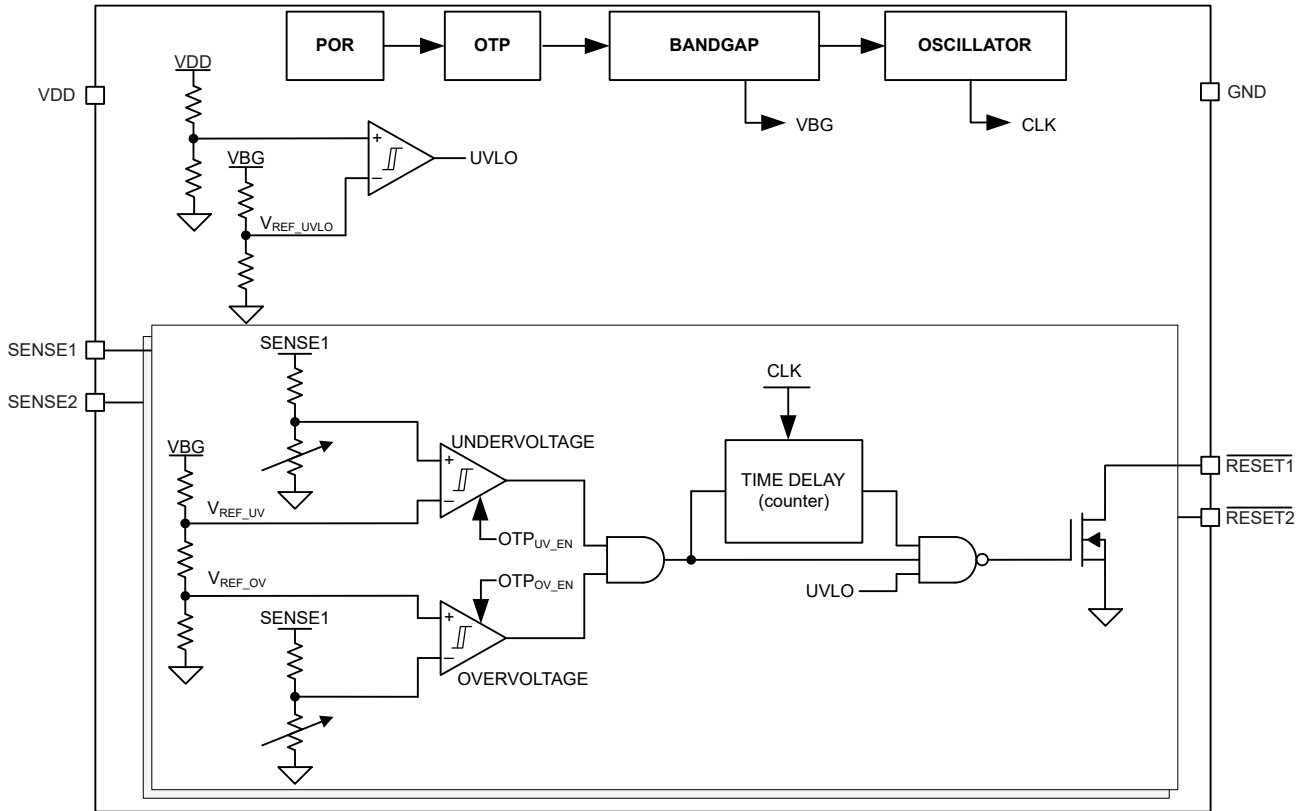

Figure 8-2. TPS37042 Dual-Channel Functional Block Diagram

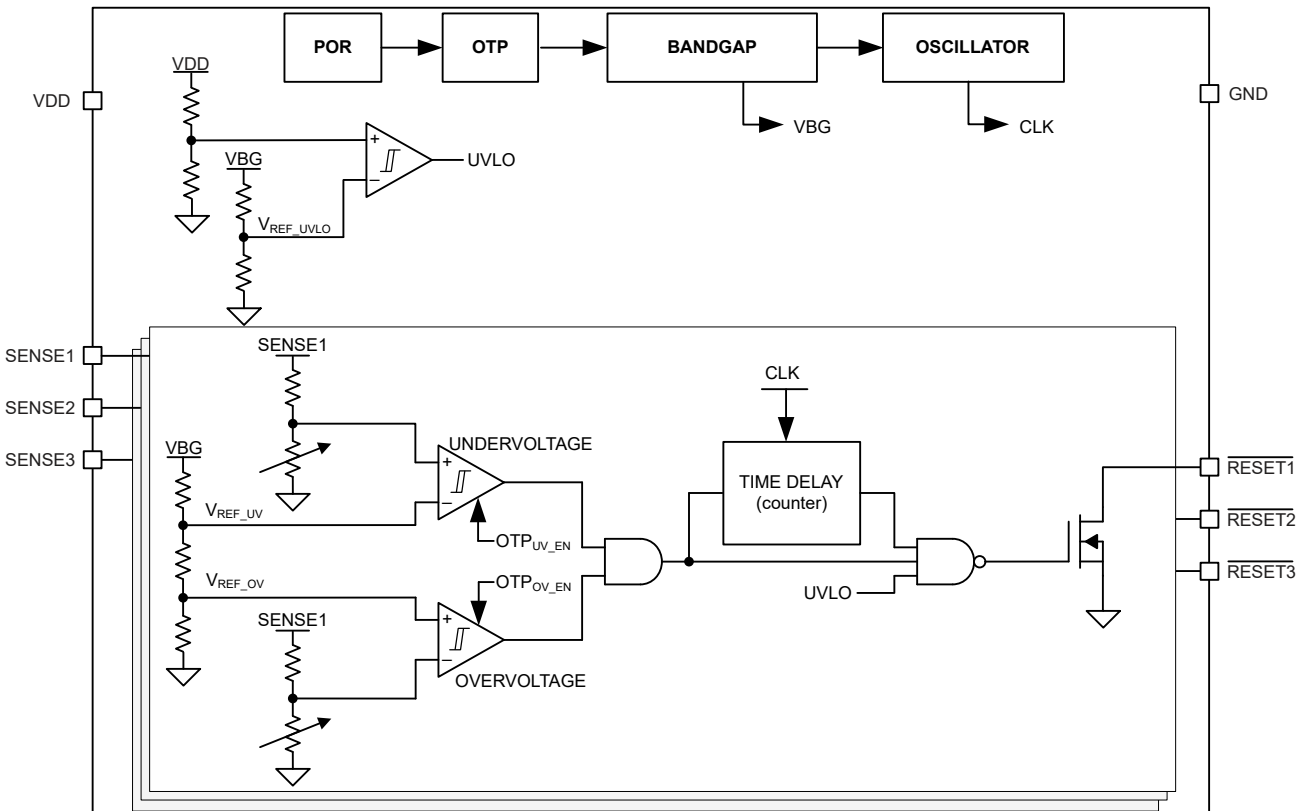

Figure 8-3. TPS37043 Triple-Channel Functional Block Diagram

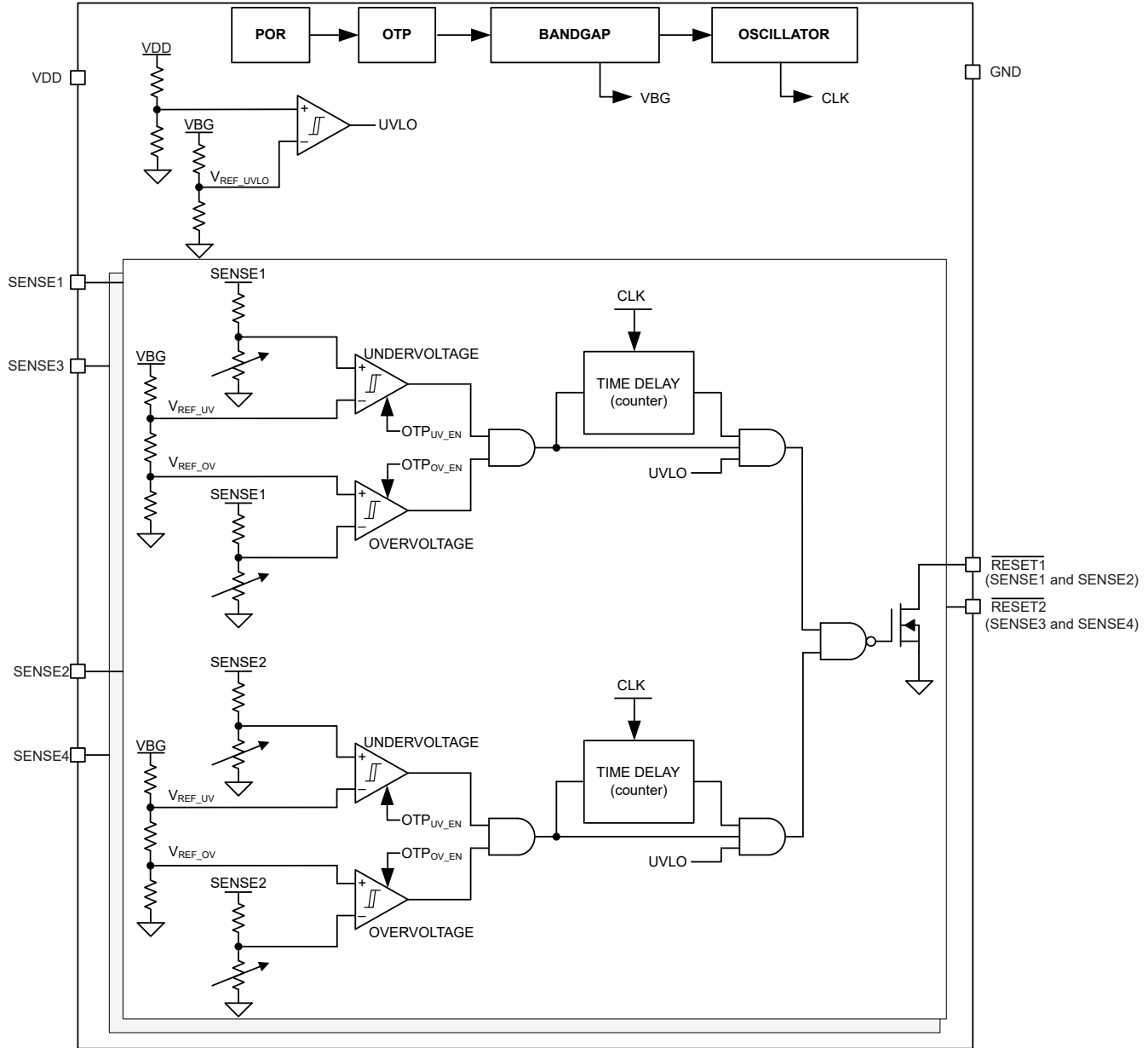

Figure 8-4. TPS37044 Quadruple-Channel Functional Block Diagram

*For available voltages, window tolerance, time delays, and UV/OV threshold options, see [Table 12-2](#).

8.3 Feature Description

8.3.1 VDD

The TPS3704x is designed to operate from an input voltage supply range between 1.7 V to 6 V. The SENSE_x pins are monitored by the internal comparator. VDD also functions as the supply for the internal bandgap, internal regulator, state machine, buffers and other control blocks. The reset signal is at a known state when $V_{DD} > V_{POR}$. Undervoltage lockout forces the reset output to be asserted when VDD falls below the minimum VDD voltage.

VDD capacitor is not required for this device; however, if the input supply is noisy, then it is good design practice to place a 0.1 μ F to 1 μ F bypass capacitor between the VDD pin and the GND pin to ensure enough charge is available for the device to power up correctly. VDD needs to be at or above $V_{DD(MIN)}$ for start-up delay ($t_{SRT} + t_D$) to begin and for the device to be fully functional.

8.3.2 SENSEx Input

The SENSEx input can monitor supply rails from 0 V to 5.55 V, regardless of the device supply voltage used. The SENSEx pins are used to monitor critical voltage rails or push-button inputs. If the voltage on this pin drops below $V_{IT-(UV)}$ or goes above $V_{IT+(OV)}$, then $\overline{\text{RESETx}}/\text{RESETx}$ is asserted. When the voltage on the SENSEx pin rises above the positive threshold voltage $V_{IT-(UV)} + V_{HYS}$ or goes below the negative threshold voltage $V_{IT+(OV)} - V_{HYS}$, $\overline{\text{RESETx}}/\text{RESETx}$ deasserts after the set $\overline{\text{RESETx}}/\text{RESETx}$ delay time. The internal comparators have built-in hysteresis to ensure well-defined $\overline{\text{RESETx}}/\text{RESETx}$ assertions and deassertions even when there are small changes on the voltage rail being monitored.

$\overline{\text{RESETx}}/\text{RESETx}$ deasserts after the set $\overline{\text{RESETx}}/\text{RESETx}$ delay time. The internal comparators have built-in hysteresis to ensure well-defined $\overline{\text{RESETx}}/\text{RESETx}$ assertions and deassertions even when there are small changes on the voltage rail being monitored.

The TPS3704x combines comparators with a precision reference voltage and a trimmed resistor divider. This configuration optimizes device accuracy because all resistor tolerances are accounted for in the accuracy and performance specifications. The TPS3704x device is relatively immune to short transients on the SENSEx pin. Although not required in most cases, for noisy applications, good analog design practice is to place a 10-nF to 100-nF bypass capacitor at the SENSEx inputs to reduce sensitivity to transient voltages on the monitored signals.

8.3.2.1 Immunity to SENSEx Pins Voltage Transients

The TPS3704x is immune to short voltage transient spikes on the input SENSEx pins. Sensitivity to transients depends on both transient duration and overdrive (amplitude) of the transient.

Overdrive is defined by how much the V_{SENSEx} exceeds the specified threshold, and is important to know because the smaller the overdrive, the slower the response of the $(\overline{\text{RESETx}}/\text{RESETx})$ outputs. Threshold overdrive is calculated as a percent of the threshold in question, as shown in [Equation 1](#):

$$\text{Overdrive \%} = | (V_{\text{SENSEx}} - (V_{IT-(UV)} \text{ or } V_{IT+(OV)})) / V_{IT} (\text{Nominal}) \times 100\% | \quad (1)$$

where:

- V_{SENSEx} is the voltage at the SENSEx pin
- $V_{IT} (\text{Nominal})$ is the nominal threshold voltage
- $V_{IT-(UV)}$ and $V_{IT+(OV)}$ represent the actual undervoltage or overvoltage tripping voltage

8.3.2.1.1 SENSEx Hysteresis

Overshoot and undervoltage comparators include built-in hysteresis that provides noise immunity and ensures stable operation. For example, if the voltage on the SENSEx pin falls below $V_{IT-(UV)}$ or above $V_{IT+(OV)}$, then $\overline{\text{RESETx}}/\text{RESETx}$ is asserted. When the voltage on the SENSEx pin is between the positive and negative threshold voltages, $\overline{\text{RESETx}}/\text{RESETx}$ deasserts after the set $\overline{\text{RESETx}}/\text{RESETx}$ delay time. [Figure 8-5](#) shows the relation between $V_{IT-(UV)}$, $V_{IT+(OV)}$ and the hysteresis voltage (V_{HYS}).

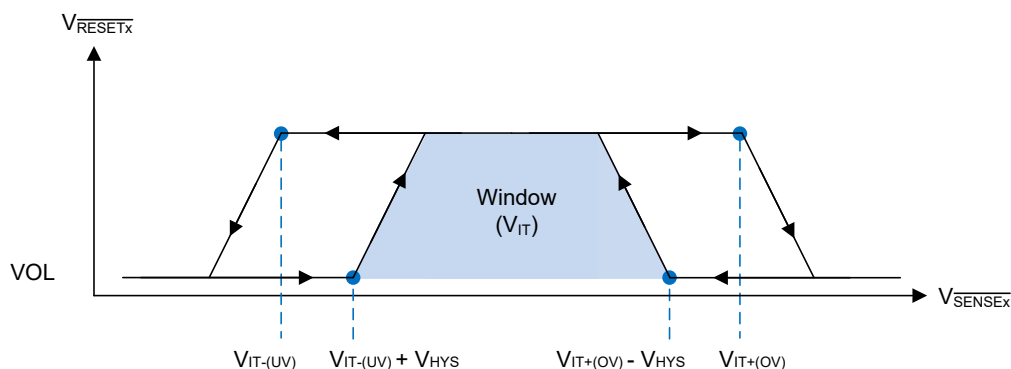

Figure 8-5. SENSEx Pin Hysteresis

8.3.3 RESETx/RESETx

In a typical TPS3704x application, the $\overline{\text{RESETx}}$ /RESETx output is connected to a reset or enable input of a processor [such as a digital signal processor (DSP), application-specific integrated circuit (ASIC), or other processor type] or the enable input of a voltage regulator [such as a DC-DC converter or low-dropout regulator (LDO)].

The TPS3704x has open drain active low outputs that requires an external pull-up resistor to hold these lines high to the required voltage logic. Connect the external pull-up resistor to the proper voltage rail to enable the output to be connected to other devices at the correct interface voltage levels. To ensure proper voltage levels, give some consideration when choosing the external pull-up resistor values. The external pull-up resistor value is determined by V_{OL} , output capacitive loading, and output leakage current. These values are specified in Section 7.5. The open drain output can be connected as a wired-OR logic with the other $\overline{\text{RESETx}}$ /RESETx open drain pins.

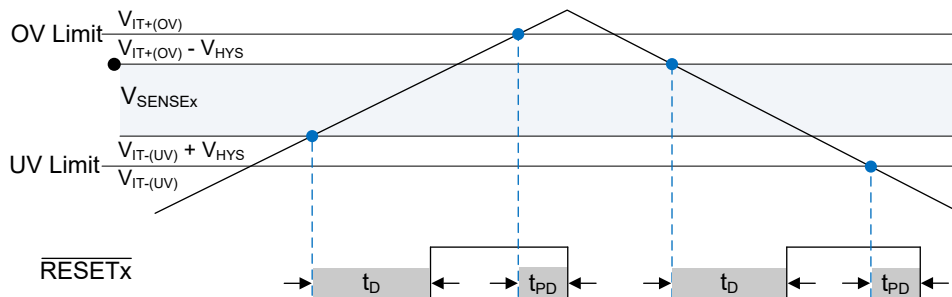

Figure 8-6. $\overline{\text{RESETx}}$ output

8.4 Device Functional Modes

Table 8-1. Functional Mode Truth Table

DESCRIPTION	CONDITION	VDD PIN	OUTPUT $\overline{\text{RESETx}}$ / (RESETx) PIN
Normal Operation	$V_{IT-(UV)} < \text{SENSEx} < V_{IT+(OV)}$	$V_{DD} > V_{DD(MIN)}$	High / (Low)
Normal Operation (UV Only)	$\text{SENSEx} > V_{IT-(UV)}$	$V_{DD} > V_{DD(MIN)}$	High / (Low)
Over Voltage detection	$\text{SENSEx} > V_{IT+(OV)}$	$V_{DD} > V_{DD(MIN)}$	Low / (High)
Under Voltage detection	$\text{SENSEx} < V_{IT-(UV)}$	$V_{DD} > V_{DD(MIN)}$	Low / (High)
UVLO engaged	$V_{IT-(UV)} < \text{SENSEx} < V_{IT+(OV)}$	$V_{POR} < V_{DD} < \text{UVLO}$	Low / (High)

8.4.1 Normal Operation ($V_{DD} > V_{DD(MIN)}$)

When the voltage on V_{DD} is greater than $V_{DD(MIN)}$ for approximately ($t_{\text{START}} + t_D$), the $\overline{\text{RESETx}}$ /RESETx output state will correspond to the SENSEx pin voltage with respect to the threshold limits, when SENSEx voltage is outside of threshold limits the $\overline{\text{RESETx}}$ /RESETx voltage will be asserted.

8.4.2 Undervoltage Lockout ($V_{POR} < V_{DD} < \text{UVLO}$)

When the voltage on V_{DD} is less than the device UVLO voltage but greater than the power-on reset voltage (V_{POR}), the $\overline{\text{RESETx}}$ /RESETx pin will be asserted, regardless of the voltage on SENSEx pin.

8.4.3 Power-On Reset ($V_{DD} < V_{POR}$)

When the voltage on V_{DD} is lower than the required voltage (V_{POR}) to internally pull the asserted output to GND, $\overline{\text{RESETx}}$ /RESETx signal is undefined and is not to be relied upon for proper device function.

9 Application and Implementation

Note

Information in the following applications sections is not part of the TI component specification, and TI does not warrant its accuracy or completeness. TI's customers are responsible for determining suitability of components for their purposes, as well as validating and testing their design implementation to confirm system functionality.

9.1 Application Information

9.1.1 Voltage Threshold Accuracy

Voltage monitoring requirements vary depending on the voltage supply tolerance of the device being powered. Due to the high precision of the TPS3704x ($\pm 1\%$ maximum), the device allows for a wider supply voltage margins and threshold headroom for tight tolerance applications.

For example, take a DC/DC regulator providing power to a core voltage rail of an MCU. The MCU has a tolerance of $\pm 5\%$ of the nominal output voltage of the DC/DC. The user sets an ideal voltage threshold of $\pm 4\%$ which allows for $\pm 1\%$ of threshold accuracy. Since the TPS3704x threshold accuracy is $\pm 1\%$, the user has more supply voltage margin which can allow for a relaxed power supply design. This gives flexibility to the DC/DC to use a smaller output capacitor or inductor because of a larger voltage window for voltage ripple and transients. There is also headroom between the minimum system voltage and voltage tolerance of the MCU to ensure that the voltage supply will never be in the region of potential failure of malfunction without the TPS3704x asserting a reset signal.

Figure 9-1 illustrates the supply undervoltage margin and accuracy of the TPS3704x for the example explained above. Using a low accuracy supervisor will eat into the available budget for the power supply ripple and transient response. This gives less flexibility to the user and a more stringent DC/DC converter design.

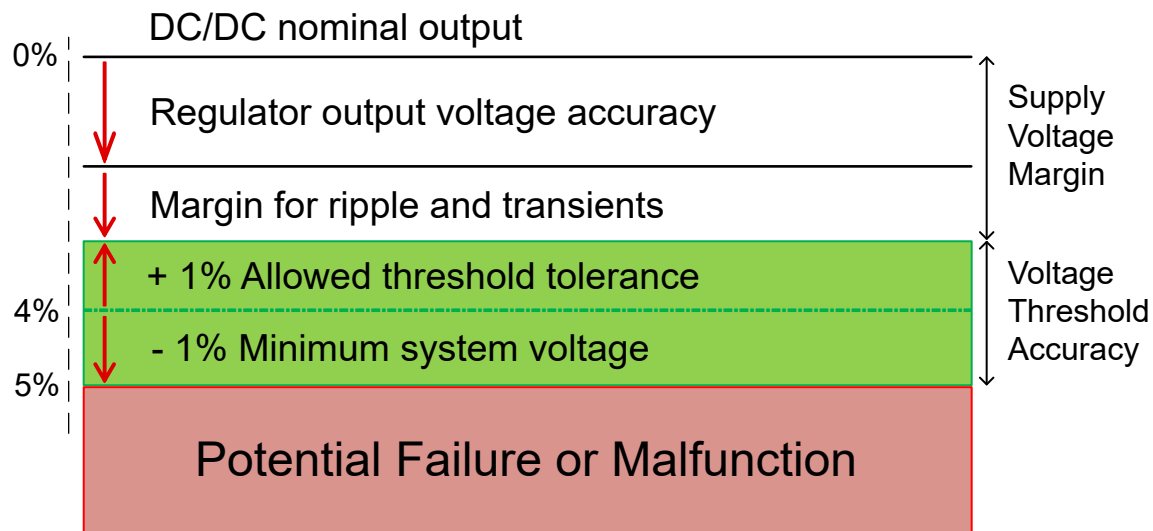

Figure 9-1. TPS3704x Voltage Threshold Accuracy

9.1.2 Adjustable Voltage Thresholds

The TPS3704x maximum accuracy (1%) allows for adjustable voltage thresholds using external resistors without adding major inaccuracies to the device. In case that the desired monitored voltage is not available, external resistor dividers can be used to set the desired voltage thresholds. Figure 9-2 illustrates an example of how to adjust the voltage threshold with external resistor dividers. The resistors can be calculated depending on the desired voltage threshold and device part number. TI recommends using an adjustable voltage threshold device variant because of the bypass mode of internal resistor ladder.

For example, consider a 2.0 V rail being monitored (V_{MON}) using the TPS3704 0.8 V adjustable variant. Using Equation 2, $R_1 = 15\text{ k}\Omega$ given that $R_2 = 10\text{ k}\Omega$, $V_{MON} = 2\text{ V}$, and $V_{SENSE1} = 0.8\text{ V}$. This device is typically meant to monitor a 0.8 V rail with $\pm 4\%$ voltage thresholds. This means that the device undervoltage threshold ($V_{IT-(UV)}$) and overvoltage threshold ($V_{IT+(OV)}$) is 0.768 V and 0.832 V respectively. Using Equation 2, $V_{MON} = 1.92\text{ V}$ when $V_{SENSE1} = V_{IT-(UV)}$. This can be denoted as V_{MON-} , the monitored undervoltage threshold where the device will assert a reset signal. Using Equation 2 again, the monitored overvoltage threshold (V_{MON+}) = 2.08 V when $V_{SENSE1} = V_{IT+(OV)}$. If a wider tolerance or UV only threshold is desired, use a device variant shown on Table 12-2 to determine what device part number matches your application.

$$V_{SENSE1} = V_{MON} \times (R_2 / (R_1 + R_2)) \quad (2)$$

There are inaccuracies that must be taken into consideration while adjusting voltage thresholds. Aside from the tolerance of the resistor divider, there is an internal resistance of the SENSE1 pin that may affect the accuracy of the resistor divider. Although expected to be very high impedance, users are recommended to calculate the values for design specifications. The internal sense resistance R_{SENSE1} can be calculated by the sense voltage V_{SENSE1} divided by the sense current I_{SENSE1} as shown in Equation 4. V_{SENSE1} can be calculated using Equation 2 depending on the resistor divider and monitored voltage. I_{SENSE1} can be calculated using Equation 3.

$$I_{SENSE1} = [(V_{MON} - V_{SENSE1}) / R_1] - (V_{SENSE1} / R_2) \quad (3)$$

$$R_{SENSE1} = V_{SENSE1} / I_{SENSE1} \quad (4)$$

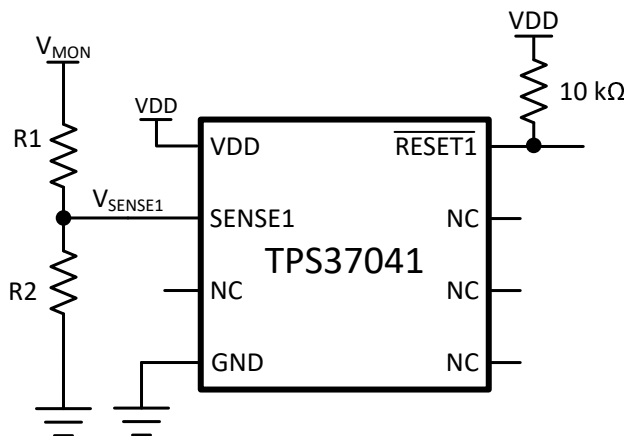

Figure 9-2. Adjustable Voltage Threshold with External Resistor Dividers

9.2 Typical Application

9.2.1 Design 1: Multi-Rail Window Monitoring for Microcontroller Power Rails

A typical application for the TPS37042 is shown in [Figure 9-3](#). The TPS37042 is used to monitor two PMIC voltage rails that powers the core and I/O voltage of the microcontroller that requires accurate reset delay and voltage supervision. It utilizes the TPS37042 to monitor the core voltage rail of a MCU similar to the circuit below.

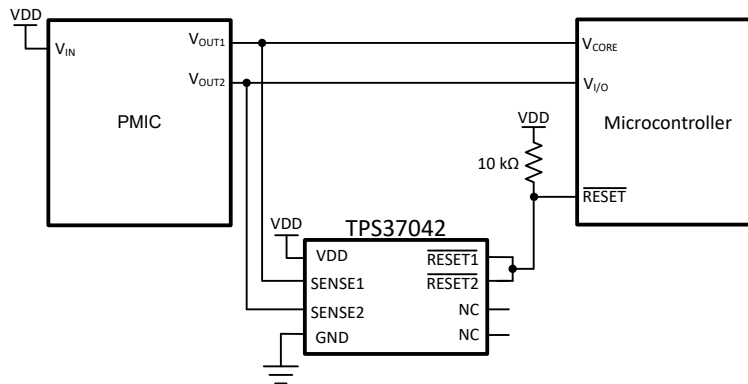

Figure 9-3. TPS37042 Dual-Channel Monitoring Two Microcontroller Power Rails

9.2.1.1 Design Requirements

Table 9-1. Design Requirements

PARAMETER	DESIGN REQUIREMENT	DESIGN RESULT
Monitored rails	3.3- $V_{I/O}$ nominal, with alerts if outside of $\pm 8\%$ of 3.3 V (including device accuracy), 10 ms reset delay	Worst case $V_{IT+(OV)} = 3.533$ V (7.06%) Worst case $V_{IT-(UV)} = 3.071$ V (-6.94%)
	1.2- V_{CORE} nominal, with alerts if outside of $\pm 5\%$ of 1.2 V (including device accuracy), 10 ms reset delay	Worst case $V_{IT+(OV)} = 1.2484$ V (4.03%) Worst case $V_{IT-(UV)} = 1.1524$ V (-3.97%)
Output logic voltage	5-V CMOS	5-V CMOS
Maximum system supervision current consumption	25 μ A	5.5 μ A (15 μ A max)

9.2.1.2 Detailed Design Procedure

Determine which version of the TPS3704x best suits the monitored rail (V_{MON}) and window tolerances found on [Table 12-2](#). The TPS3704x allows overvoltage and undervoltage monitoring for precise voltage supervision of common rails between 0.4 V and 5.55 V. This application calls for very tight monitoring of the rail with only $\pm 5\%$ of variation allowed on the 1.2- V_{CORE} rail. To ensure this requirement is met, the TPS37042 was chosen for its $\pm 3\%$ thresholds. The 3.3- $V_{I/O}$ is more flexible and can operate up to 8% variance. Since the TPS3704x comes in various tolerance options, the $\pm 6\%$ thresholds can be chosen for this voltage rail. To calculate the worst-case for $V_{IT+(OV)}$ and $V_{IT-(UV)}$, the accuracy must also be taken into account. The worst-case for $V_{IT+(OV)}$ and $V_{IT-(UV)}$ can be calculated shown in [Equation 5](#) and [Equation 6](#) respectively:

$$V_{IT+(OV-Worst\ Case)} = V_{MON} \times (1 + \%Threshold) \times (1 + \%Accuracy) = 1.2 \times (1.03) \times (1.01) = 1.2484 \text{ V} \quad (5)$$

$$V_{IT-(UV-Worst\ Case)} = V_{MON} \times (1 - \%Threshold) \times (1 - \%Accuracy) = 1.2 \times (0.97) \times (0.99) = 1.1524 \text{ V} \quad (6)$$

Hysteresis is also needed to be taken into account when determining the OV and UV thresholds such that the release point after the fault is higher than the power supply tolerance limits. Refer to [Figure 7-1](#) for more details.

When the outputs switch to a high impedance state, the rise time of the $\overline{\text{RESET}}_x/\text{RESET}_x$ pin depends on the pull-up resistance and the capacitance on that node. Choose pull-up resistors that satisfy both the downstream timing requirements and the sink current required to have a V_{OL} low enough for the application; 10 k Ω to 1 M Ω resistors are a good choice for low-capacitive loads.

9.2.2 Application Curves

These application curves were taken with the TPS3704Q1EVM. Please see the [TPS3704Q1EVM User Guide](#) for more information.

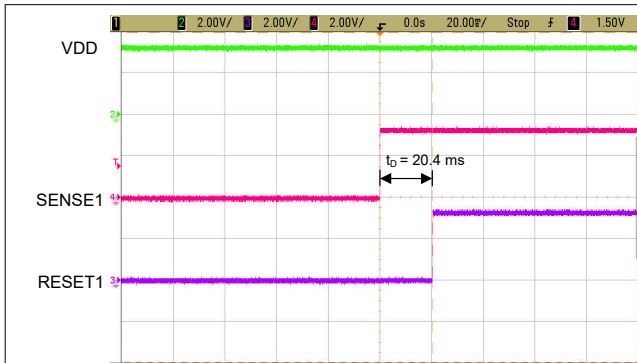

V_{SENSE1} start up 0 V to 3.3 V, $V_{DD} = 3.3$ V, $V_{RESET1} = 3.3$ V,
 TPS37044A7OHDDFR

Figure 9-4. TPS37044 SENSE1 Start Up Function

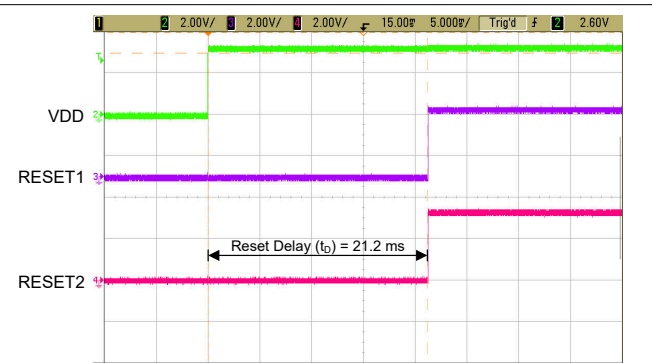

V_{DD} start up 0 V to 3.3 V, $V_{SENSE1} = 3.3$ V, $V_{SENSE2} = 1.8$ V,
 $V_{SENSE3,4} = 1.15$ V, $V_{RESET1,2} = 3.3$ V, TPS37044A7OHDDFR

Figure 9-5. TPS37044 VDD Start Up Function

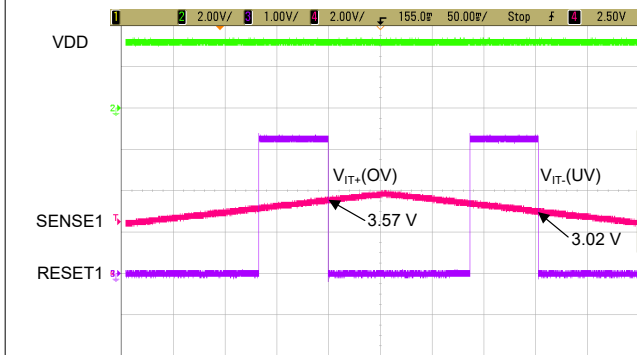

V_{SENSE1} ramp 0 V to 3.75 V, OV/UV Threshold = 3.3 V
 ($\pm 8\%$), $V_{SENSE2} = 1.8$ V, $V_{DD} = 3.3$ V, $V_{RESET1} = 3.3$ V,
 TPS37044A7OHDDFR

Figure 9-6. TPS37044 Overtolerance and Undervoltage Function

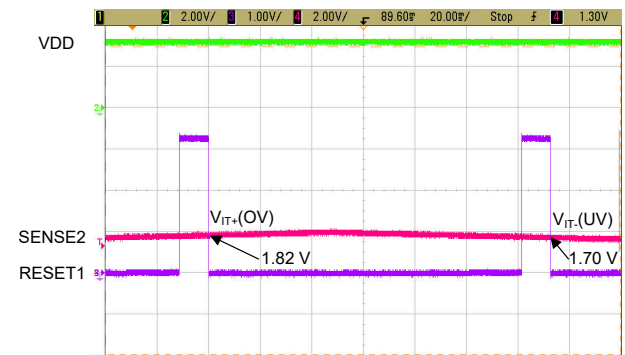

V_{SENSE2} ramp 0 V to 2 V, OV/UV Threshold = 1.8 V
 (+4%, -3.5%), $V_{SENSE1} = 3.3$ V, $V_{DD} = 3.3$ V,
 $V_{RESET1} = 3.3$ V, TPS37044A7OHDDFR

Figure 9-7. TPS37044 Overtolerance and Undervoltage Function

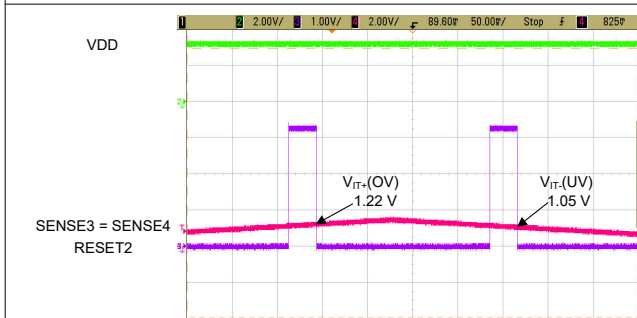

$V_{SENSE3,4}$ ramp 0 V to 1.5 V, OV/UV Threshold = 1.15
 V (+7.5%, -5.5%), $V_{DD} = 3.3$ V, $V_{RESET2} = 3.3$ V,
 TPS37044A7OHDDFR

Figure 9-8. TPS37044 Overtolerance and Undervoltage Function

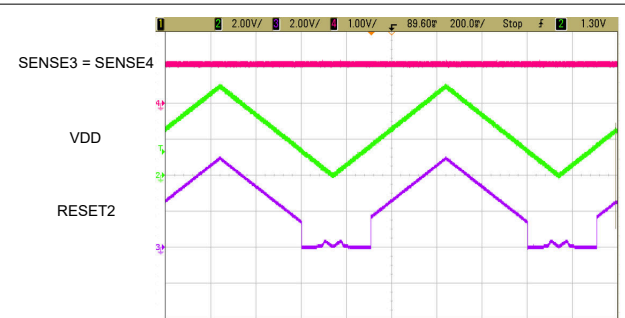

V_{DD} ramp 0 V to 5 V, $V_{SENSE3,4} = 1.2$ V, $V_{RESET2} = 3.3$ V,
 TPS37044A7OHDDFR

Figure 9-9. TPS37044 VDD Ramp Up Function

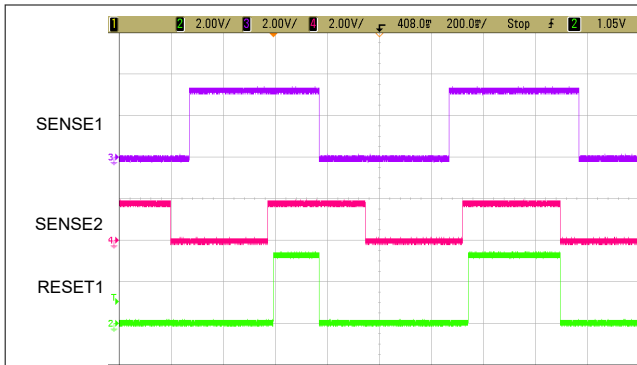

V_{SENSE1} toggling 0 V to 3.3 V [OV/UV Threshold = 3.3 V ($\pm 8\%$)], V_{SENSE2} toggling from 0 V to 1.8 V [OV/UV Threshold = 1.8 V (+4%, -3.5%)], $V_{DD} = 3.3$ V, $V_{RESET1} = 3.3$ V, TPS37044A7OHDDFR

Figure 9-10. TPS37044 SENSE 1 and SENSE 2 Toggling

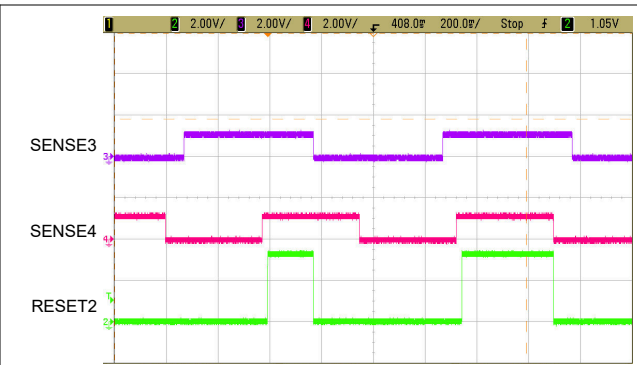

V_{SENSE3} toggling 0 V to 1.15 V [OV/UV Threshold = 1.15 V (+7.5%, -5.5%)], V_{SENSE4} toggling from 0 V to 1.15 V [OV/UV Threshold = 1.15 V (+7.5%, -5.5%)], $V_{DD} = 3.3$ V, $V_{RESET1} = 3.3$ V, TPS37044A7OHDDFR

Figure 9-11. TPS37044 SENSE 3 and SENSE 4 Toggling

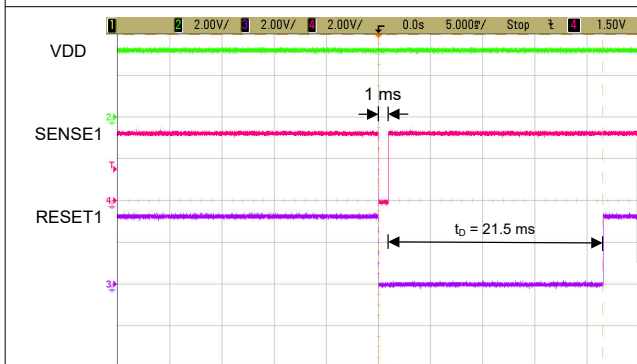

$V_{SENSE1} = 3.3$ V, $V_{SENSE1} = 0$ V via push-button for 1 ms, $V_{DD} = 3.3$ V, $V_{RESET1} = 3.3$ V, TPS37044A7OHDDFR

Figure 9-12. TPS37044 SENSE1 Push-Button Monitoring Function with Reset Time Delay

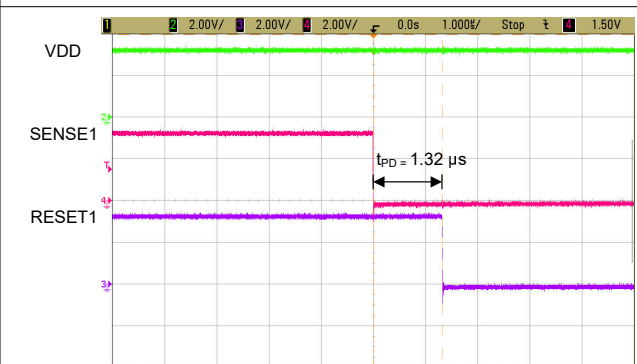

V_{SENSE1} toggling from 3.3 V to 0 V, $V_{DD} = 3.3$ V, V_{RESET1} toggling from 3.3 V to 0 V, TPS37044A7OHDDFR

Figure 9-13. TPS37044 SENSE1 Propagation Delay Function

10 Power Supply Recommendations

10.1 Power Supply Guidelines

This device is designed to operate from an input supply with a voltage range between 1.7 V to 6 V. It has a 6.5 V absolute maximum rating on the VDD pin. It is good analog practice to place a 0.1 μ F to 1 μ F capacitor between the VDD pin and the GND pin depending on the input voltage supply noise. If the voltage supply providing power to VDD is susceptible to any large voltage transient that exceed maximum specifications, additional precautions must be taken. See [SNVA849](#) for more information.

11 Layout

11.1 Layout Guidelines

- Place the external components as close to the device as possible. This configuration prevents parasitic errors from occurring.
- Avoid using long traces for the VDD supply node. The VDD capacitor, along with parasitic inductance from the supply to the capacitor, can form an LC circuit and create ringing with peak voltages above the maximum VDD voltage.
- Avoid using long traces of voltage to the sense pin. Long traces increase parasitic inductance and cause inaccurate monitoring and diagnostics.
- If SENSEx capacitors (C_{SENSEx}) are used, place the capacitors as close as possible to the SENSEx pins to further improve the noise immunity on the SENSEx pins. Placing a 10 nF to 100 nF capacitors between the SENSEx pins and GND can reduce the sensitivity to transient voltages on the monitored signal.
- Do not run sensitive analog traces in parallel with digital traces. Avoid crossing digital and analog traces if possible, and only make perpendicular crossings when absolutely necessary.

11.2 Layout Example

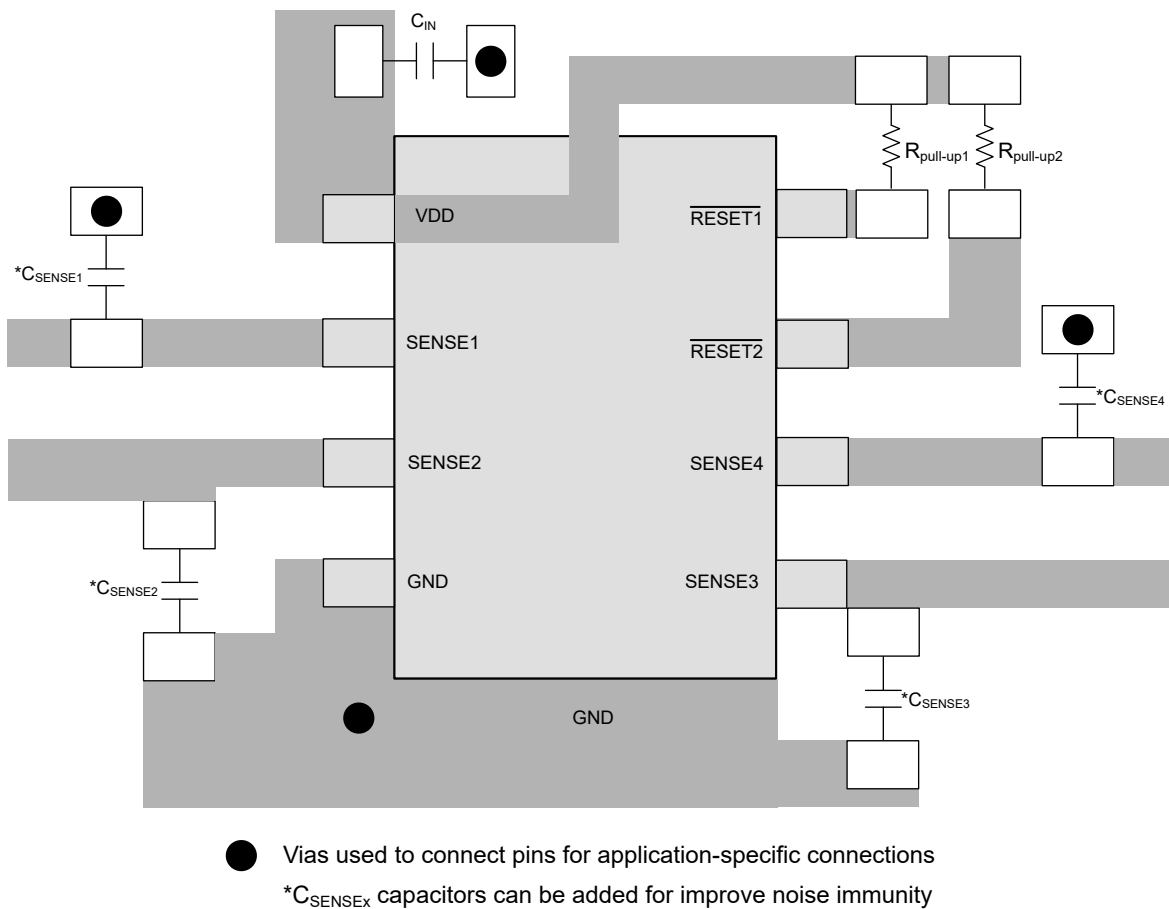

Figure 11-1. Recommended Layout

12 Device and Documentation Support

12.1 Device Nomenclature

Figure 5-1 in Section 5 and Table 12-1 shows how to decode the function of the device based on its part number shown in Table 12-2.

Table 12-1. Device Naming Convention

DESCRIPTION	NOMENCLATURE	VALUE
Generic Part number	TPS3704x	TPS3704x
Channel Option	1	One-channel option
	2	Dual-channel option
	3	Triple-channel option
	4	Quad-channel option
Detection Options	Ax, Bx, Cx,...	Please refer to Table 12-2
Variant code (Output Topology)	O	Open-Drain, Active-Low
	L	Push-Pull, Active-Low
	H	Push-Pull, Active-High
Reset Time Delay Option	A	20 μ s reset time delay
	B	1 ms reset time delay
	C	2 ms reset time delay
	D	3 ms reset time delay
	E	5 ms reset time delay
	F	10 ms reset time delay
	G	15 ms reset time delay
	H	20 ms reset time delay
	I	25 ms reset time delay
	J	35 ms reset time delay
	K	40 ms reset time delay
	L	50 ms reset time delay
	M	70 ms reset time delay
	N	100 ms reset time delay
	O	140 ms reset time delay
	P	150 ms reset time delay
	R	200 ms reset time delay
	S	280 ms reset time delay
	T	400 ms reset time delay
	U	560 ms reset time delay
V	800 ms reset time delay	
W	1120 ms reset time delay	
X	1200 ms reset time delay	
Package	DDF	SOT-23 8-pin (1.6 mm \times 2.9 mm)
Reel	R	Large Reel

Table 12-2. Device Threshold Table

ORDERABLE PART NAME	VARIANT	NUM OF CHAN.	RESET TIME	SENSE1	SENSE2	SENSE3	SENSE4
TPS37044BJOFDDFR	TPS37044	4	10 ms	0.8 V (±4%)	0.8 V (±4%)	0.8 V (±4%)	0.8 V (±4%)

12.2 Receiving Notification of Documentation Updates

To receive notification of documentation updates, navigate to the device product folder on ti.com. Click on *Subscribe to updates* to register and receive a weekly digest of any product information that has changed. For change details, review the revision history included in any revised document.

12.3 Support Resources

[TI E2E™ support forums](#) are an engineer's go-to source for fast, verified answers and design help — straight from the experts. Search existing answers or ask your own question to get the quick design help you need.

Linked content is provided "AS IS" by the respective contributors. They do not constitute TI specifications and do not necessarily reflect TI's views; see TI's [Terms of Use](#).

12.4 Trademarks

TI E2E™ is a trademark of Texas Instruments.

All trademarks are the property of their respective owners.

12.5 Electrostatic Discharge Caution



This integrated circuit can be damaged by ESD. Texas Instruments recommends that all integrated circuits be handled with appropriate precautions. Failure to observe proper handling and installation procedures can cause damage.

ESD damage can range from subtle performance degradation to complete device failure. Precision integrated circuits may be more susceptible to damage because very small parametric changes could cause the device not to meet its published specifications.

12.6 Glossary

[TI Glossary](#) This glossary lists and explains terms, acronyms, and definitions.

13 Mechanical, Packaging, and Orderable Information

The following pages include mechanical, packaging, and orderable information. This information is the most current data available for the designated devices. This data is subject to change without notice and revision of this document. For browser-based versions of this data sheet, refer to the left-hand navigation.

PACKAGING INFORMATION

Orderable Device	Status (1)	Package Type	Package Drawing	Pins	Package Qty	Eco Plan (2)	Lead finish/ Ball material (6)	MSL Peak Temp (3)	Op Temp (°C)	Device Marking (4/5)	Samples
TPS37044BJOFDDFR	ACTIVE	SOT-23-THIN	DDF	8	3000	RoHS & Green	NIPDAU	Level-1-260C-UNLIM	-40 to 125	4BJOF	Samples

(1) The marketing status values are defined as follows:

ACTIVE: Product device recommended for new designs.

LIFEBUY: TI has announced that the device will be discontinued, and a lifetime-buy period is in effect.

NRND: Not recommended for new designs. Device is in production to support existing customers, but TI does not recommend using this part in a new design.

PREVIEW: Device has been announced but is not in production. Samples may or may not be available.

OBSOLETE: TI has discontinued the production of the device.

(2) **RoHS:** TI defines "RoHS" to mean semiconductor products that are compliant with the current EU RoHS requirements for all 10 RoHS substances, including the requirement that RoHS substance do not exceed 0.1% by weight in homogeneous materials. Where designed to be soldered at high temperatures, "RoHS" products are suitable for use in specified lead-free processes. TI may reference these types of products as "Pb-Free".

RoHS Exempt: TI defines "RoHS Exempt" to mean products that contain lead but are compliant with EU RoHS pursuant to a specific EU RoHS exemption.

Green: TI defines "Green" to mean the content of Chlorine (Cl) and Bromine (Br) based flame retardants meet JS709B low halogen requirements of <=1000ppm threshold. Antimony trioxide based flame retardants must also meet the <=1000ppm threshold requirement.

(3) MSL, Peak Temp. - The Moisture Sensitivity Level rating according to the JEDEC industry standard classifications, and peak solder temperature.

(4) There may be additional marking, which relates to the logo, the lot trace code information, or the environmental category on the device.

(5) Multiple Device Markings will be inside parentheses. Only one Device Marking contained in parentheses and separated by a "-" will appear on a device. If a line is indented then it is a continuation of the previous line and the two combined represent the entire Device Marking for that device.

(6) Lead finish/Ball material - Orderable Devices may have multiple material finish options. Finish options are separated by a vertical ruled line. Lead finish/Ball material values may wrap to two lines if the finish value exceeds the maximum column width.

Important Information and Disclaimer:The information provided on this page represents TI's knowledge and belief as of the date that it is provided. TI bases its knowledge and belief on information provided by third parties, and makes no representation or warranty as to the accuracy of such information. Efforts are underway to better integrate information from third parties. TI has taken and continues to take reasonable steps to provide representative and accurate information but may not have conducted destructive testing or chemical analysis on incoming materials and chemicals. TI and TI suppliers consider certain information to be proprietary, and thus CAS numbers and other limited information may not be available for release.

In no event shall TI's liability arising out of such information exceed the total purchase price of the TI part(s) at issue in this document sold by TI to Customer on an annual basis.

OTHER QUALIFIED VERSIONS OF TPS3704 :

- Automotive : [TPS3704-Q1](#)

NOTE: Qualified Version Definitions:

- Automotive - Q100 devices qualified for high-reliability automotive applications targeting zero defects

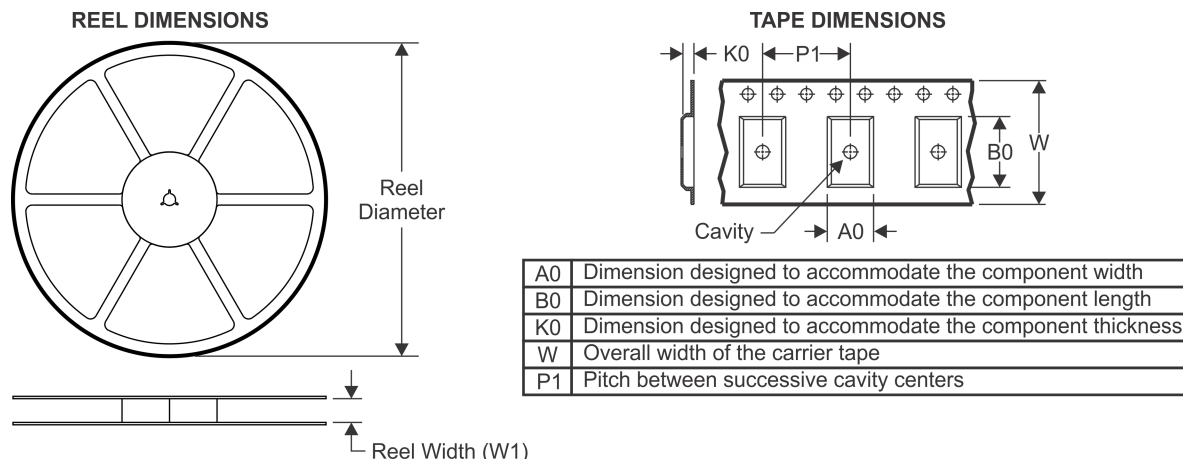
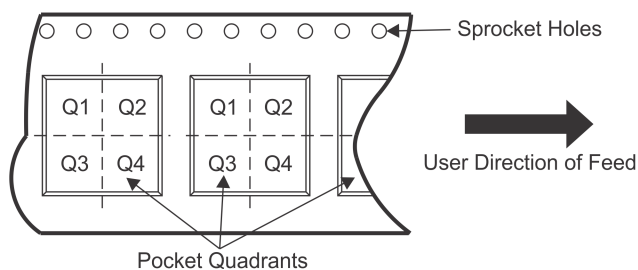
TAPE AND REEL INFORMATION

QUADRANT ASSIGNMENTS FOR PIN 1 ORIENTATION IN TAPE

*All dimensions are nominal

Device	Package Type	Package Drawing	Pins	SPQ	Reel Diameter (mm)	Reel Width W1 (mm)	A0 (mm)	B0 (mm)	K0 (mm)	P1 (mm)	W (mm)	Pin1 Quadrant
TPS37044BJOFDDFR	SOT-23-THIN	DDF	8	3000	180.0	8.4	3.2	3.2	1.4	4.0	8.0	Q3

TAPE AND REEL BOX DIMENSIONS

*All dimensions are nominal

Device	Package Type	Package Drawing	Pins	SPQ	Length (mm)	Width (mm)	Height (mm)
TPS37044BJOFDDFR	SOT-23-THIN	DDF	8	3000	210.0	185.0	35.0

EXAMPLE STENCIL DESIGN

DDF0008A

SOT-23 - 1.1 mm max height

PLASTIC SMALL OUTLINE

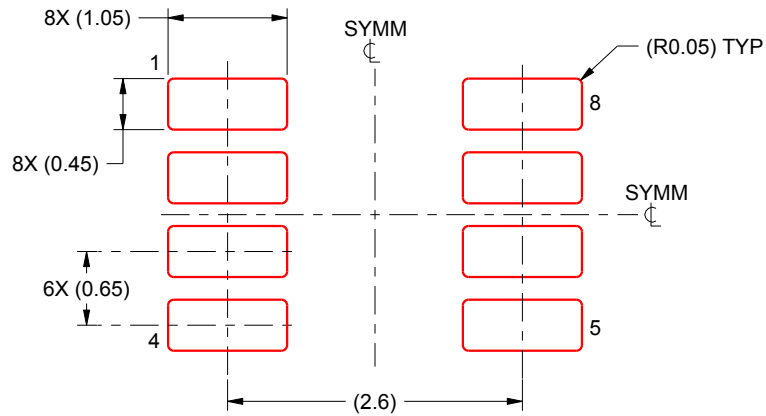

SOLDER PASTE EXAMPLE
BASED ON 0.125 mm THICK STENCIL
SCALE:15X

4222047/B 11/2015

NOTES: (continued)

6. Laser cutting apertures with trapezoidal walls and rounded corners may offer better paste release. IPC-7525 may have alternate design recommendations.
7. Board assembly site may have different recommendations for stencil design.

IMPORTANT NOTICE AND DISCLAIMER

TI PROVIDES TECHNICAL AND RELIABILITY DATA (INCLUDING DATA SHEETS), DESIGN RESOURCES (INCLUDING REFERENCE DESIGNS), APPLICATION OR OTHER DESIGN ADVICE, WEB TOOLS, SAFETY INFORMATION, AND OTHER RESOURCES "AS IS" AND WITH ALL FAULTS, AND DISCLAIMS ALL WARRANTIES, EXPRESS AND IMPLIED, INCLUDING WITHOUT LIMITATION ANY IMPLIED WARRANTIES OF MERCHANTABILITY, FITNESS FOR A PARTICULAR PURPOSE OR NON-INFRINGEMENT OF THIRD PARTY INTELLECTUAL PROPERTY RIGHTS.

These resources are intended for skilled developers designing with TI products. You are solely responsible for (1) selecting the appropriate TI products for your application, (2) designing, validating and testing your application, and (3) ensuring your application meets applicable standards, and any other safety, security, regulatory or other requirements.

These resources are subject to change without notice. TI grants you permission to use these resources only for development of an application that uses the TI products described in the resource. Other reproduction and display of these resources is prohibited. No license is granted to any other TI intellectual property right or to any third party intellectual property right. TI disclaims responsibility for, and you will fully indemnify TI and its representatives against, any claims, damages, costs, losses, and liabilities arising out of your use of these resources.

TI's products are provided subject to [TI's Terms of Sale](#) or other applicable terms available either on ti.com or provided in conjunction with such TI products. TI's provision of these resources does not expand or otherwise alter TI's applicable warranties or warranty disclaimers for TI products.

TI objects to and rejects any additional or different terms you may have proposed.

Mailing Address: Texas Instruments, Post Office Box 655303, Dallas, Texas 75265
Copyright © 2022, Texas Instruments Incorporated