

SN54ALS520, SN74ALS518, SN74ALS520, SN74ALS521 8-BIT IDENTITY COMPARATORS

SDAS224B – JUNE 1982 – REVISED NOVEMBER 1995

- Compare Two 8-Bit Words
- Choice of Totem-Pole or Open-Collector Outputs
- SN74ALS518 and 'ALS520 Have 20-k Ω Pullup Resistors on Q Inputs
- Package Options Include Plastic Small-Outline (DW) Packages, Ceramic Chip Carriers (FK), and Standard Plastic (N) and Ceramic (J) 300-mil DIPs

TYPE	INPUT PULLUP RESISTOR	OUTPUT FUNCTION AND CONFIGURATION
SN74ALS518	Yes	P = Q open collector
'ALS520	Yes	$\overline{P = Q}$ totem pole
SN74ALS521 [‡]	No	P = Q totem pole

[‡] SN74ALS521 is identical to 'ALS688.

description

These identity comparators perform comparisons on two 8-bit binary or BCD words. The SN74ALS518 provides P = Q outputs, while the 'ALS520 and SN74ALS521 provide $\overline{P = Q}$ outputs. The SN74ALS518 has an open-collector output. The SN74ALS518 and 'ALS520 feature 20-k Ω pullup resistors on the Q inputs for analog or switch data.

The SN54ALS520 is characterized for operation over the full military temperature range of -55°C to 125°C. The SN74ALS518, SN74ALS520, and SN74ALS521 are characterized for operation from 0°C to 70°C.

SN54ALS520 . . . J PACKAGE
SN74ALS518, SN74ALS520,
SN74ALS521 . . . DW OR N PACKAGE
(TOP VIEW)

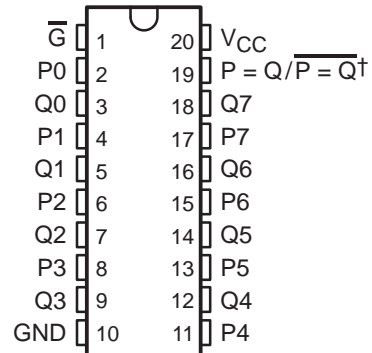

[†] $\overline{P = Q}$ for SN74ALS518
P = Q for 'ALS520 and SN74ALS521

SN54ALS520 . . . FK PACKAGE
(TOP VIEW)

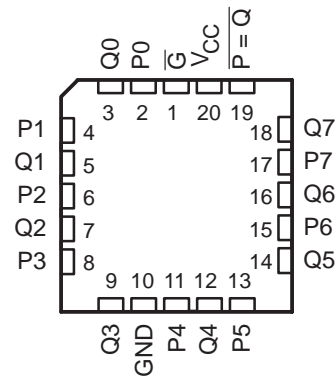

FUNCTION TABLE

INPUTS		OUTPUTS	
DATA P, Q	ENABLE \overline{G}	P = Q	$\overline{P = Q}$
P = Q	L	H	L
P > Q	L	L	H
P < Q	L	L	H
X	H	L	H

SN54ALS520, SN74ALS518, SN74ALS520, SN74ALS521 8-BIT IDENTITY COMPARATORS

SDAS224B – JUNE 1982 – REVISED NOVEMBER 1995

logic symbols†

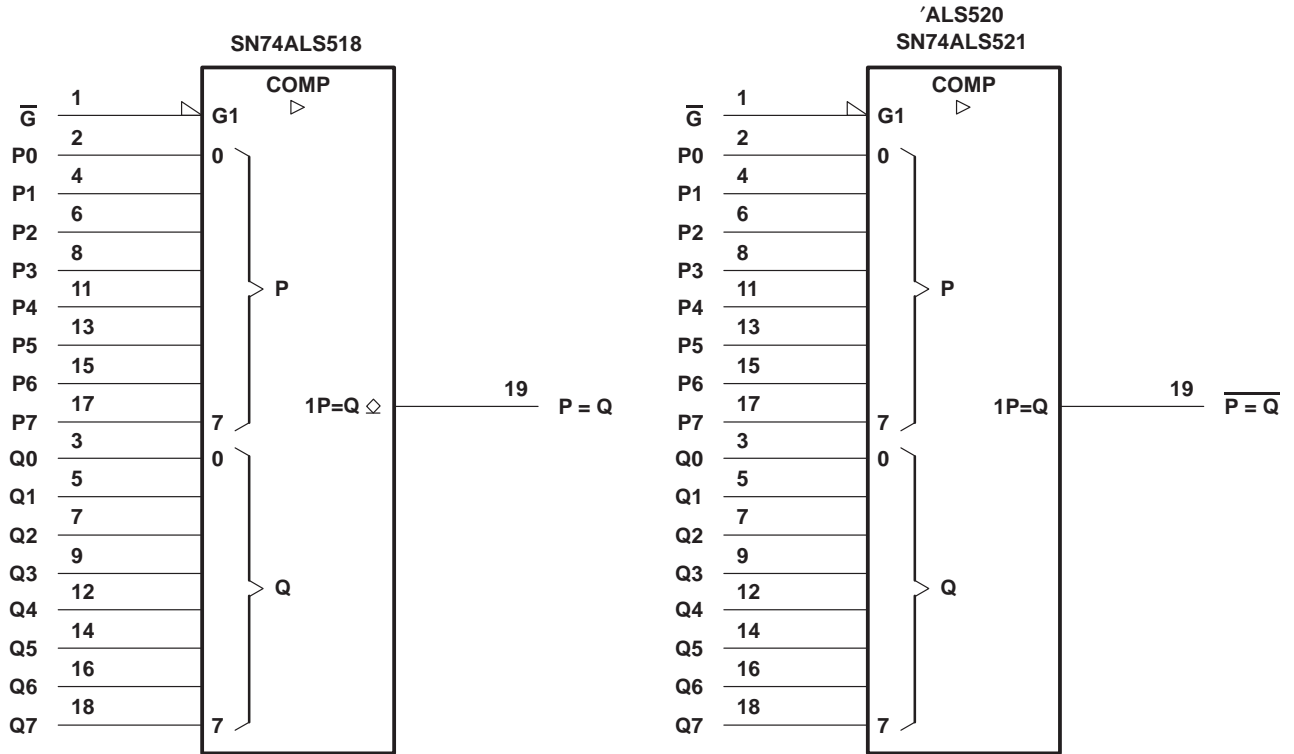

† These symbols are in accordance with ANSI/IEEE Std 91-1984 and IEC Publication 617-12.

SN54ALS520, SN74ALS518, SN74ALS520, SN74ALS521 8-BIT IDENTITY COMPARATORS

SDAS224B – JUNE 1982 – REVISED NOVEMBER 1995

logic diagrams (positive logic)

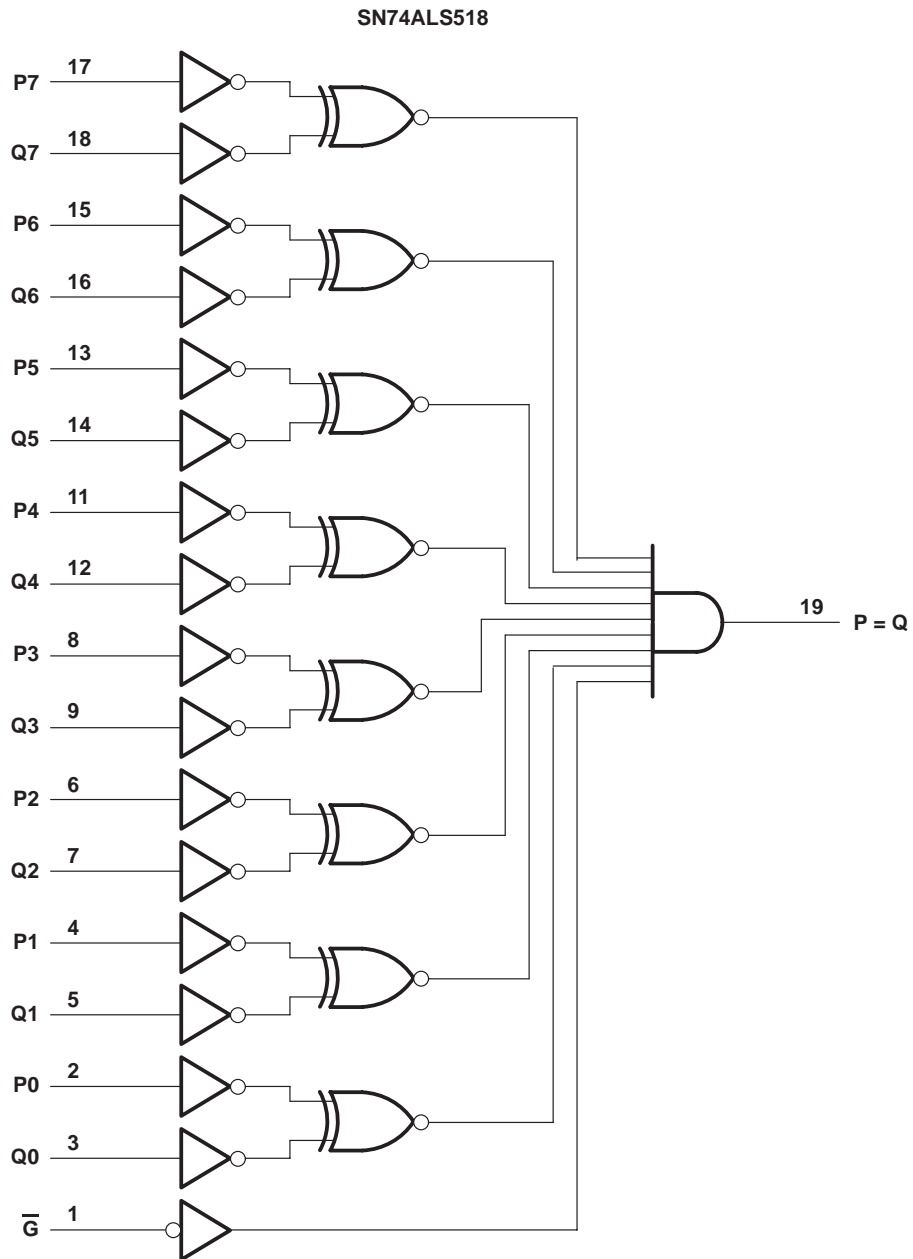

SN54ALS520, SN74ALS518, SN74ALS520, SN74ALS521 8-BIT IDENTITY COMPARATORS

SDAS224B – JUNE 1982 – REVISED NOVEMBER 1995

logic diagrams (positive logic) (continued)

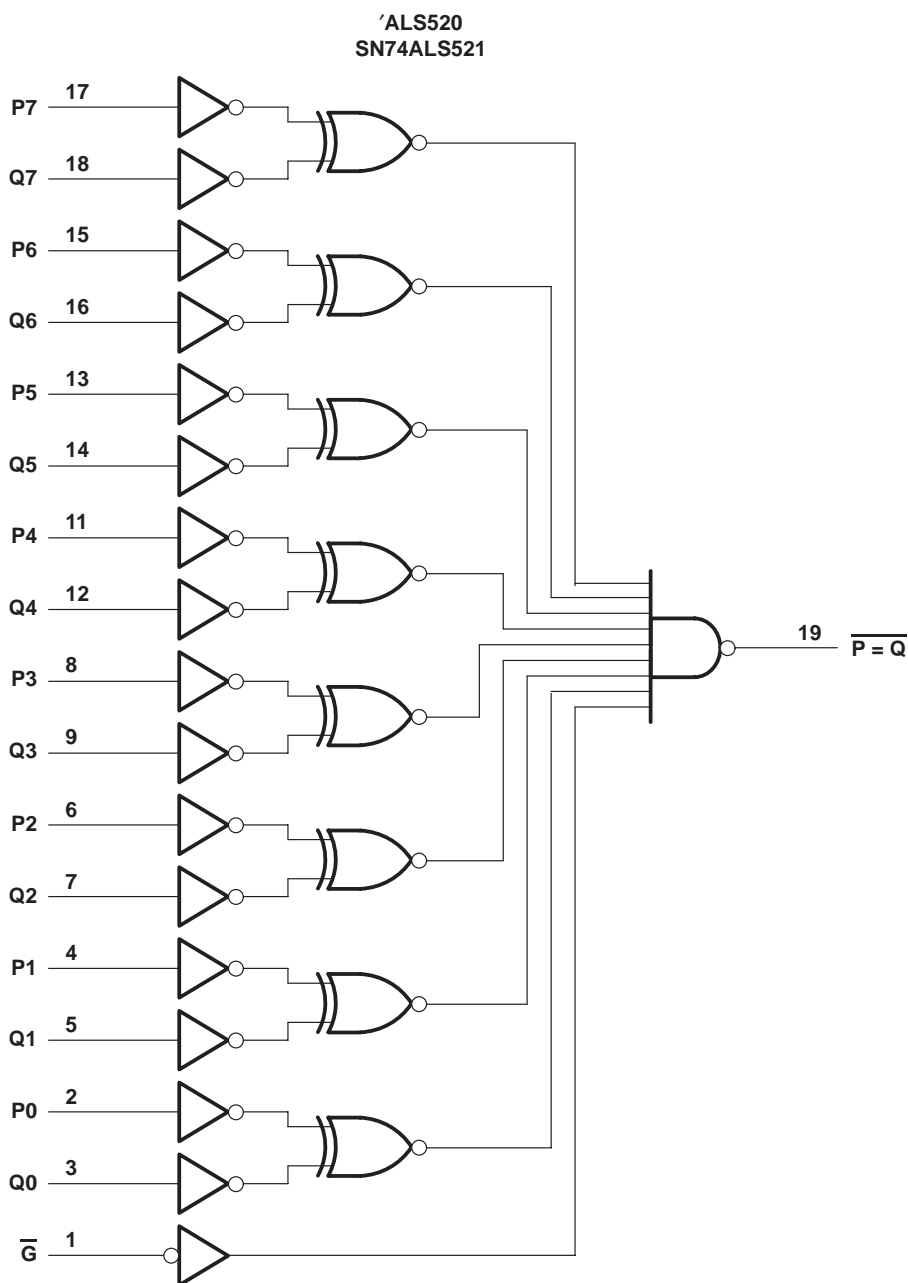

SN54ALS520, SN74ALS518, SN74ALS520, SN74ALS521 8-BIT IDENTITY COMPARATORS

SDAS224B – JUNE 1982 – REVISED NOVEMBER 1995

absolute maximum ratings over operating free-air temperature range (unless otherwise noted)†

Supply voltage, V_{CC}	7 V
Input voltage, V_I : Q inputs	$V_{CC} + 0.5$ V or 5.5 V, whichever is less
All other inputs	7 V
Off-state output voltage	7 V
Operating free-air temperature range, T_A : SN74ALS518	0°C to 70°C
Storage temperature range	–65°C to 150°C

† Stresses beyond those listed under “absolute maximum ratings” may cause permanent damage to the device. These are stress ratings only, and functional operation of the device at these or any other conditions beyond those indicated under “recommended operating conditions” is not implied. Exposure to absolute-maximum-rated conditions for extended periods may affect device reliability.

recommended operating conditions

		SN74ALS518			UNIT
		MIN	NOM	MAX	
V_{CC}	Supply voltage	4.5	5	5.5	V
V_{IH}	High-level input voltage	2			V
V_{IL}	Low-level input voltage			0.8	V
V_{OH}	High-level output voltage			5.5	V
I_{OL}	Low-level output current			24	mA
T_A	Operating free-air temperature	0		70	°C

electrical characteristics over recommended operating free-air temperature range (unless otherwise noted)

PARAMETER		TEST CONDITIONS		SN74ALS518		UNIT
				MIN	TYP‡	
V_{IK}		$V_{CC} = 4.5$ V,	$I_I = -18$ mA		–1.5	V
I_{OH}		$V_{CC} = 5.5$ V,	$V_{OH} = 5.5$ V		0.1	mA
V_{OL}		$V_{CC} = 4.5$ V	$I_{OL} = 12$ mA	0.25	0.4	V
			$I_{OL} = 24$ mA	0.35	0.5	
I_I	Q inputs	$V_{CC} = 5.5$ V	$V_I = 5.5$ V		0.1	mA
	All other inputs		$V_I = 7$ V		0.1	
I_{IH}	Q inputs	$V_{CC} = 5.5$ V,	$V_I = 2.7$ V		–0.2	mA
	All other inputs				20	
I_{IL}	Q inputs	$V_{CC} = 5.5$ V,	$V_I = 0.4$ V		–0.6	mA
	All other inputs				–0.1	
I_{CC}		$V_{CC} = 5.5$ V,	See Note 1	11	17	mA

‡ All typical values are at $V_{CC} = 5$ V, $T_A = 25^\circ\text{C}$.

NOTE 1: I_{CC} is measured with \bar{G} grounded, and P and Q at 4.5 V.



SN54ALS520, SN74ALS518, SN74ALS520, SN74ALS521 8-BIT IDENTITY COMPARATORS

SDAS224B – JUNE 1982 – REVISED NOVEMBER 1995

switching characteristics (see Figure 1)

PARAMETER	FROM (INPUT)	TO (OUTPUT)	V _{CC} = 4.5 V to 5.5 V, C _L = 50 pF, R _L = 680 Ω, T _A = MIN to MAX†		UNIT
			SN74ALS518		
			MIN	MAX	
t _{PLH}	P or Q	P = Q	15	33	ns
t _{PHL}			3	15	
t _{PLH}	\bar{G}	P = Q	15	33	ns
t _{PHL}			3	15	

† For conditions shown as MIN or MAX, use the appropriate value specified under recommended operating conditions.

absolute maximum ratings over operating free-air temperature range (unless otherwise noted)‡

Supply voltage, V _{CC}	7 V
Input voltage, V _I : Q inputs of 'ALS520	V _{CC} + 0.5 V or 5.5 V, whichever is less
All other inputs	7 V
Operating free-air temperature range, T _A : SN54ALS520	–55°C to 125°C
SN74ALS520, SN74ALS521	0°C to 70°C
Storage temperature range	–65°C to 150°C

‡ Stresses beyond those listed under “absolute maximum ratings” may cause permanent damage to the device. These are stress ratings only, and functional operation of the device at these or any other conditions beyond those indicated under “recommended operating conditions” is not implied. Exposure to absolute-maximum-rated conditions for extended periods may affect device reliability.

recommended operating conditions

	SN54ALS520			SN74ALS520 SN74ALS521			UNIT
	MIN	NOM	MAX	MIN	NOM	MAX	
V _{CC} Supply voltage	4.5	5	5.5	4.5	5	5.5	V
V _{IH} High-level input voltage	2			2			V
V _{IL} Low-level input voltage			0.7			0.8	V
I _{OH} High-level output current			–1			–2.6	mA
I _{OL} Low-level output current			12			24	mA
T _A Operating free-air temperature	–55		125	0		70	°C

SN54ALS520, SN74ALS518, SN74ALS520, SN74ALS521 8-BIT IDENTITY COMPARATORS

SDAS224B – JUNE 1982 – REVISED NOVEMBER 1995

electrical characteristics over recommended operating free-air temperature range (unless otherwise noted)

PARAMETER		TEST CONDITIONS	SN54ALS520			SN74ALS520 SN74ALS521			UNIT
			MIN	TYP†	MAX	MIN	TYP†	MAX	
V_{IK}		$V_{CC} = 4.5\text{ V}$, $I_I = -18\text{ mA}$	-1.5			-1.5			V
V_{OH}		$V_{CC} = 4.5\text{ V to }5.5\text{ V}$, $I_{OH} = -0.4\text{ mA}$	$V_{CC} - 2$			$V_{CC} - 2$			V
		$V_{CC} = 4.5\text{ V}$ $I_{OH} = -1\text{ mA}$	2.4	3.3					
V_{OL}		$V_{CC} = 4.5\text{ V}$ $I_{OL} = 12\text{ mA}$	0.25	0.4	0.25	0.4	V		
		$V_{CC} = 4.5\text{ V}$ $I_{OL} = 24\text{ mA}$			0.35	0.5			
I_I	'ALS520 Q inputs	$V_{CC} = 5.5\text{ V}$ $V_I = 5.5\text{ V}$	0.1			0.1			mA
	All other inputs		0.1			0.1			
I_{IH}	'ALS520 Q inputs	$V_{CC} = 5.5\text{ V}$, $V_I = 2.7\text{ V}$	-0.2			-0.2			mA
	All other inputs		20			20			
I_{IL}	'ALS520 Q inputs	$V_{CC} = 5.5\text{ V}$, $V_I = 0.4\text{ V}$	-0.6			-0.6			mA
	All other inputs		-0.1			-0.1			
I_O^\ddagger		$V_{CC} = 5.5\text{ V}$, $V_O = 2.25\text{ V}$	-20	-112	-30	-112	mA		
I_{CC}	'ALS520	$V_{CC} = 5.5\text{ V}$, See Note 1	12	19	12	19	mA		
	SN74ALS521		12	19	12	19			

† All typical values are at $V_{CC} = 5\text{ V}$, $T_A = 25^\circ\text{C}$.

‡ The output conditions have been chosen to produce a current that closely approximates one half of the true short-circuit output current, I_{OS} .

NOTE 1: I_{CC} is measured with \bar{G} grounded, and P and Q at 4.5 V.

switching characteristics (see Figure 1)

PARAMETER	FROM (INPUT)	TO (OUTPUT)	$V_{CC} = 4.5\text{ V to }5.5\text{ V}$, $C_L = 50\text{ pF}$, $R_L = 500\ \Omega$, $T_A = \text{MIN to MAX}^\S$				UNIT
			SN54ALS520		SN74ALS520 SN74ALS521		
			MIN	MAX	MIN	MAX	
t_{PLH}	P or Q	$\overline{P = Q}$	3	19	3	12	ns
t_{PHL}			3	25	5	20	
t_{PLH}	G	$P = Q$	2	18	2	12	ns
t_{PHL}			5	23	5	22	

§ For conditions shown as MIN or MAX, use the appropriate value specified under recommended operating conditions.

SN54ALS520, SN74ALS518, SN74ALS520, SN74ALS521 8-BIT IDENTITY COMPARATORS

SDAS224B – JUNE 1982 – REVISED NOVEMBER 1995

PARAMETER MEASUREMENT INFORMATION SERIES 54ALS/74ALS AND 54AS/74AS DEVICES

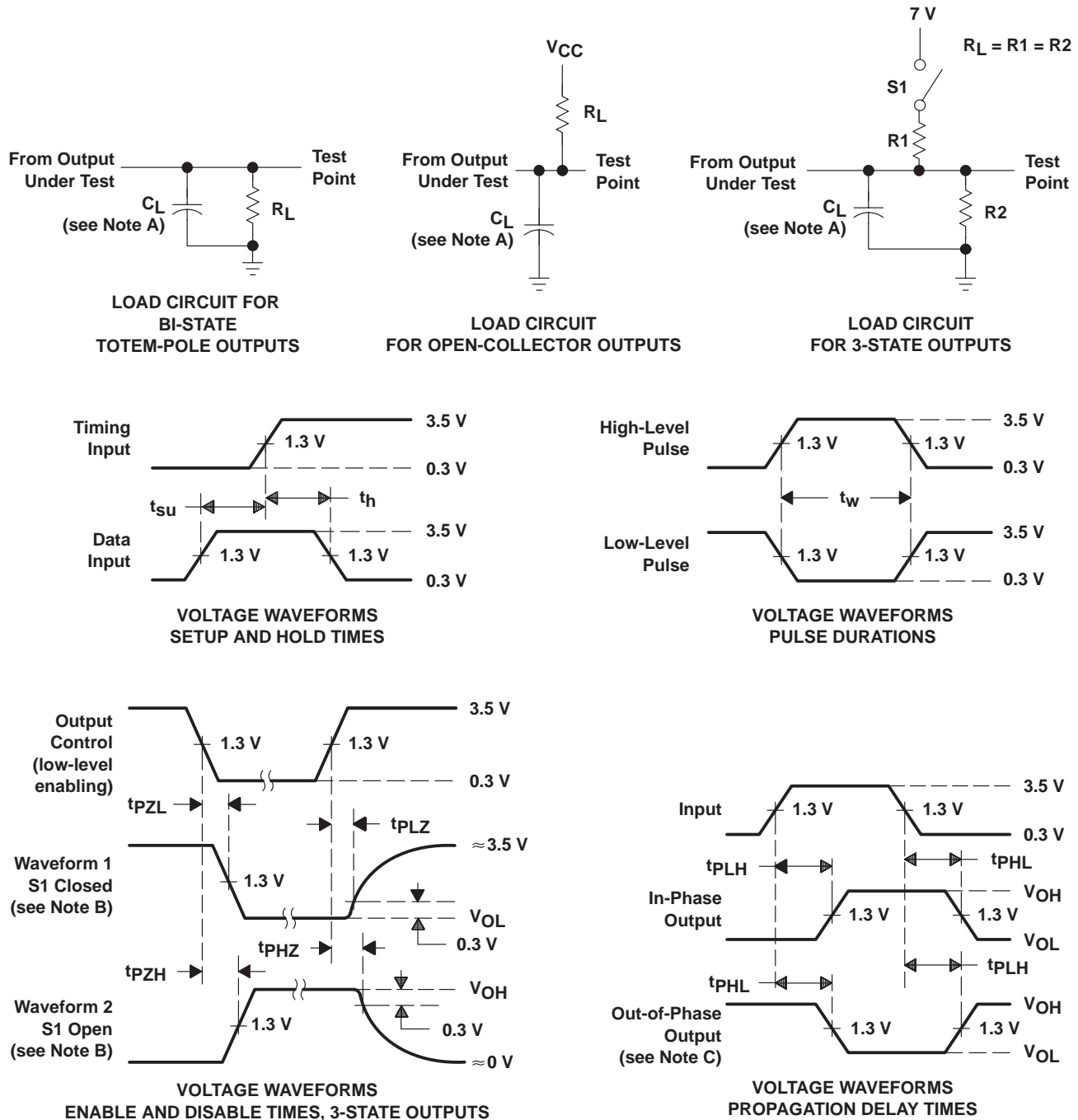

- NOTES: A. C_L includes probe and jig capacitance.
 B. Waveform 1 is for an output with internal conditions such that the output is low except when disabled by the output control. Waveform 2 is for an output with internal conditions such that the output is high except when disabled by the output control.
 C. When measuring propagation delay items of 3-state outputs, switch S1 is open.
 D. All input pulses have the following characteristics: $PRR \leq 1$ MHz, $t_r = t_f = 2$ ns, duty cycle = 50%.
 E. The outputs are measured one at a time with one transition per measurement.

Figure 1. Load Circuits and Voltage Waveforms

PACKAGING INFORMATION

Orderable Device	Status (1)	Package Type	Package Drawing	Pins	Package Qty	Eco Plan (2)	Lead finish/ Ball material (6)	MSL Peak Temp (3)	Op Temp (°C)	Device Marking (4/5)	Samples
5962-88691012A	ACTIVE	LCCC	FK	20	1	Non-RoHS & Green	SNPB	N / A for Pkg Type	-55 to 125	5962-88691012A SNJ54ALS520FK	Samples
5962-8869101RA	ACTIVE	CDIP	J	20	1	Non-RoHS & Green	SNPB	N / A for Pkg Type	-55 to 125	5962-8869101RA SNJ54ALS520J	Samples
SN54ALS520J	ACTIVE	CDIP	J	20	1	Non-RoHS & Green	SNPB	N / A for Pkg Type	-55 to 125	SN54ALS520J	Samples
SN74ALS518DW	ACTIVE	SOIC	DW	20	25	RoHS & Green	NIPDAU	Level-1-260C-UNLIM	0 to 70	ALS518	Samples
SN74ALS518DWE4	ACTIVE	SOIC	DW	20	25	RoHS & Green	NIPDAU	Level-1-260C-UNLIM	0 to 70	ALS518	Samples
SN74ALS518N	ACTIVE	PDIP	N	20	20	RoHS & Non-Green	NIPDAU	N / A for Pkg Type	0 to 70	SN74ALS518N	Samples
SN74ALS520DW	ACTIVE	SOIC	DW	20	25	RoHS & Green	NIPDAU	Level-1-260C-UNLIM	0 to 70	ALS520	Samples
SN74ALS520N	ACTIVE	PDIP	N	20	20	RoHS & Non-Green	NIPDAU	N / A for Pkg Type	0 to 70	SN74ALS520N	Samples
SN74ALS520NSR	ACTIVE	SO	NS	20	2000	RoHS & Green	NIPDAU	Level-1-260C-UNLIM	0 to 70	ALS520	Samples
SN74ALS521DW	ACTIVE	SOIC	DW	20	25	RoHS & Green	NIPDAU	Level-1-260C-UNLIM	0 to 70	ALS521	Samples
SN74ALS521DWR	ACTIVE	SOIC	DW	20	2000	RoHS & Green	NIPDAU	Level-1-260C-UNLIM	0 to 70	ALS521	Samples
SN74ALS521DWRE4	ACTIVE	SOIC	DW	20	2000	RoHS & Green	NIPDAU	Level-1-260C-UNLIM	0 to 70	ALS521	Samples
SN74ALS521N	ACTIVE	PDIP	N	20	20	RoHS & Non-Green	NIPDAU	N / A for Pkg Type	0 to 70	SN74ALS521N	Samples
SN74ALS521NSR	ACTIVE	SO	NS	20	2000	RoHS & Green	NIPDAU	Level-1-260C-UNLIM	0 to 70	ALS521	Samples
SNJ54ALS520FK	ACTIVE	LCCC	FK	20	1	Non-RoHS & Green	SNPB	N / A for Pkg Type	-55 to 125	5962-88691012A SNJ54ALS520FK	Samples
SNJ54ALS520J	ACTIVE	CDIP	J	20	1	Non-RoHS & Green	SNPB	N / A for Pkg Type	-55 to 125	5962-8869101RA SNJ54ALS520J	Samples

(1) The marketing status values are defined as follows:

ACTIVE: Product device recommended for new designs.

LIFEBUY: TI has announced that the device will be discontinued, and a lifetime-buy period is in effect.

NRND: Not recommended for new designs. Device is in production to support existing customers, but TI does not recommend using this part in a new design.

PREVIEW: Device has been announced but is not in production. Samples may or may not be available.

OBSOLETE: TI has discontinued the production of the device.

(2) **RoHS:** TI defines "RoHS" to mean semiconductor products that are compliant with the current EU RoHS requirements for all 10 RoHS substances, including the requirement that RoHS substance do not exceed 0.1% by weight in homogeneous materials. Where designed to be soldered at high temperatures, "RoHS" products are suitable for use in specified lead-free processes. TI may reference these types of products as "Pb-Free".

RoHS Exempt: TI defines "RoHS Exempt" to mean products that contain lead but are compliant with EU RoHS pursuant to a specific EU RoHS exemption.

Green: TI defines "Green" to mean the content of Chlorine (Cl) and Bromine (Br) based flame retardants meet JS709B low halogen requirements of ≤ 1000 ppm threshold. Antimony trioxide based flame retardants must also meet the ≤ 1000 ppm threshold requirement.

(3) MSL, Peak Temp. - The Moisture Sensitivity Level rating according to the JEDEC industry standard classifications, and peak solder temperature.

(4) There may be additional marking, which relates to the logo, the lot trace code information, or the environmental category on the device.

(5) Multiple Device Markings will be inside parentheses. Only one Device Marking contained in parentheses and separated by a "~" will appear on a device. If a line is indented then it is a continuation of the previous line and the two combined represent the entire Device Marking for that device.

(6) Lead finish/Ball material - Orderable Devices may have multiple material finish options. Finish options are separated by a vertical ruled line. Lead finish/Ball material values may wrap to two lines if the finish value exceeds the maximum column width.

Important Information and Disclaimer: The information provided on this page represents TI's knowledge and belief as of the date that it is provided. TI bases its knowledge and belief on information provided by third parties, and makes no representation or warranty as to the accuracy of such information. Efforts are underway to better integrate information from third parties. TI has taken and continues to take reasonable steps to provide representative and accurate information but may not have conducted destructive testing or chemical analysis on incoming materials and chemicals. TI and TI suppliers consider certain information to be proprietary, and thus CAS numbers and other limited information may not be available for release.

In no event shall TI's liability arising out of such information exceed the total purchase price of the TI part(s) at issue in this document sold by TI to Customer on an annual basis.

OTHER QUALIFIED VERSIONS OF SN54ALS520, SN74ALS520 :

● Catalog : [SN74ALS520](#)

● Military : [SN54ALS520](#)

NOTE: Qualified Version Definitions:

- Catalog - TI's standard catalog product
- Military - QML certified for Military and Defense Applications

TAPE AND REEL INFORMATION

QUADRANT ASSIGNMENTS FOR PIN 1 ORIENTATION IN TAPE



*All dimensions are nominal

Device	Package Type	Package Drawing	Pins	SPQ	Reel Diameter (mm)	Reel Width W1 (mm)	A0 (mm)	B0 (mm)	K0 (mm)	P1 (mm)	W (mm)	Pin1 Quadrant
SN74ALS520NSR	SO	NS	20	2000	330.0	24.4	8.4	13.0	2.5	12.0	24.0	Q1
SN74ALS521DWR	SOIC	DW	20	2000	330.0	24.4	10.8	13.3	2.7	12.0	24.0	Q1
SN74ALS521NSR	SO	NS	20	2000	330.0	24.4	8.4	13.0	2.5	12.0	24.0	Q1

TAPE AND REEL BOX DIMENSIONS

*All dimensions are nominal

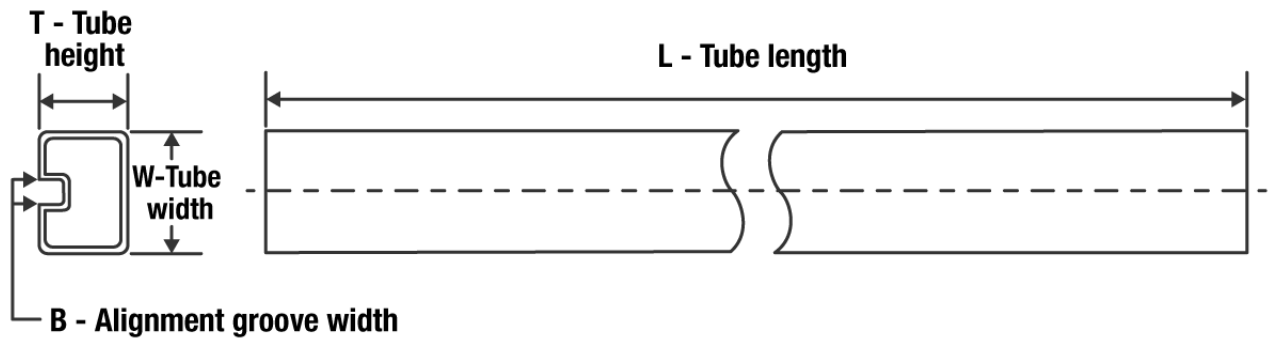
Device	Package Type	Package Drawing	Pins	SPQ	Length (mm)	Width (mm)	Height (mm)
SN74ALS520NSR	SO	NS	20	2000	367.0	367.0	45.0
SN74ALS521DWR	SOIC	DW	20	2000	367.0	367.0	45.0
SN74ALS521NSR	SO	NS	20	2000	367.0	367.0	45.0

TUBE

*All dimensions are nominal

Device	Package Name	Package Type	Pins	SPQ	L (mm)	W (mm)	T (μm)	B (mm)
5962-88691012A	FK	LCCC	20	1	506.98	12.06	2030	NA
SN74ALS518DW	DW	SOIC	20	25	507	12.83	5080	6.6
SN74ALS518DWE4	DW	SOIC	20	25	507	12.83	5080	6.6
SN74ALS518N	N	PDIP	20	20	506	13.97	11230	4.32
SN74ALS520DW	DW	SOIC	20	25	507	12.83	5080	6.6
SN74ALS520N	N	PDIP	20	20	506	13.97	11230	4.32
SN74ALS521DW	DW	SOIC	20	25	507	12.83	5080	6.6
SN74ALS521N	N	PDIP	20	20	506	13.97	11230	4.32
SNJ54ALS520FK	FK	LCCC	20	1	506.98	12.06	2030	NA

FK (S-CQCC-N**)

LEADLESS CERAMIC CHIP CARRIER

28 TERMINAL SHOWN

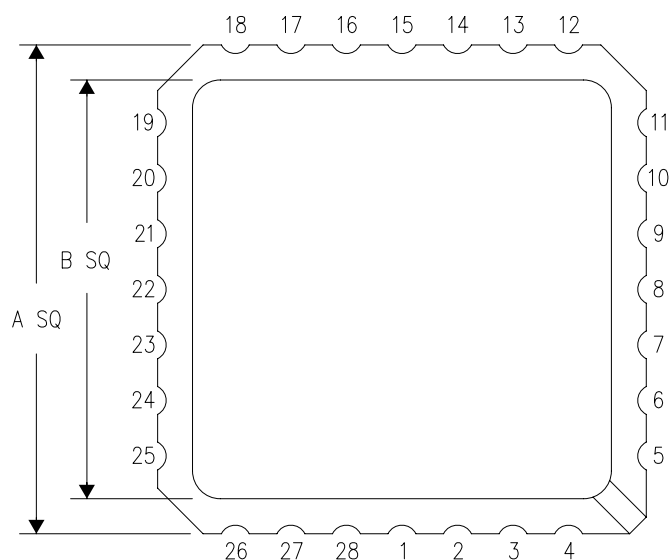

NO. OF TERMINALS **	A		B	
	MIN	MAX	MIN	MAX
20	0.342 (8,69)	0.358 (9,09)	0.307 (7,80)	0.358 (9,09)
28	0.442 (11,23)	0.458 (11,63)	0.406 (10,31)	0.458 (11,63)
44	0.640 (16,26)	0.660 (16,76)	0.495 (12,58)	0.560 (14,22)
52	0.740 (18,78)	0.761 (19,32)	0.495 (12,58)	0.560 (14,22)
68	0.938 (23,83)	0.962 (24,43)	0.850 (21,6)	0.858 (21,8)
84	1.141 (28,99)	1.165 (29,59)	1.047 (26,6)	1.063 (27,0)

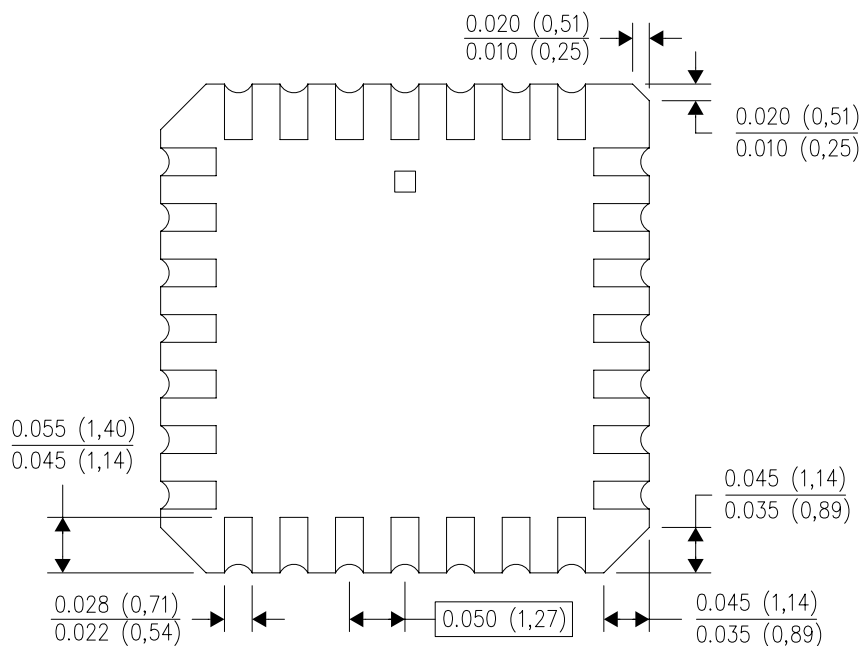

4040140/D 01/11

- NOTES:
- All linear dimensions are in inches (millimeters).
 - This drawing is subject to change without notice.
 - This package can be hermetically sealed with a metal lid.
 - Falls within JEDEC MS-004

MECHANICAL DATA

NS (R-PDSO-G**)

PLASTIC SMALL-OUTLINE PACKAGE

14-PINS SHOWN



- NOTES:
- A. All linear dimensions are in millimeters.
 - B. This drawing is subject to change without notice.
 - C. Body dimensions do not include mold flash or protrusion, not to exceed 0,15.

J (R-GDIP-T**)

14 LEADS SHOWN

CERAMIC DUAL IN-LINE PACKAGE



DIM \ PINS **	14	16	18	20
A	0.300 (7,62) BSC	0.300 (7,62) BSC	0.300 (7,62) BSC	0.300 (7,62) BSC
B MAX	0.785 (19,94)	.840 (21,34)	0.960 (24,38)	1.060 (26,92)
B MIN	—	—	—	—
C MAX	0.300 (7,62)	0.300 (7,62)	0.310 (7,87)	0.300 (7,62)
C MIN	0.245 (6,22)	0.245 (6,22)	0.220 (5,59)	0.245 (6,22)



4040083/F 03/03

- NOTES:
- A. All linear dimensions are in inches (millimeters).
 - B. This drawing is subject to change without notice.
 - C. This package is hermetically sealed with a ceramic lid using glass frit.
 - D. Index point is provided on cap for terminal identification only on press ceramic glass frit seal only.
 - E. Falls within MIL STD 1835 GDIP1-T14, GDIP1-T16, GDIP1-T18 and GDIP1-T20.

N (R-PDIP-T**)

PLASTIC DUAL-IN-LINE PACKAGE

16 PINS SHOWN



4040049/E 12/2002

- NOTES:
- A. All linear dimensions are in inches (millimeters).
 - B. This drawing is subject to change without notice.
 - $\triangle C$ Falls within JEDEC MS-001, except 18 and 20 pin minimum body length (Dim A).
 - $\triangle D$ The 20 pin end lead shoulder width is a vendor option, either half or full width.

DW0020A



PACKAGE OUTLINE

SOIC - 2.65 mm max height

SOIC



NOTES:

1. All linear dimensions are in millimeters. Dimensions in parenthesis are for reference only. Dimensioning and tolerancing per ASME Y14.5M.
2. This drawing is subject to change without notice.
3. This dimension does not include mold flash, protrusions, or gate burrs. Mold flash, protrusions, or gate burrs shall not exceed 0.15 mm per side.
4. This dimension does not include interlead flash. Interlead flash shall not exceed 0.43 mm per side.
5. Reference JEDEC registration MS-013.

EXAMPLE BOARD LAYOUT

DW0020A

SOIC - 2.65 mm max height

SOIC



LAND PATTERN EXAMPLE
SCALE:6X

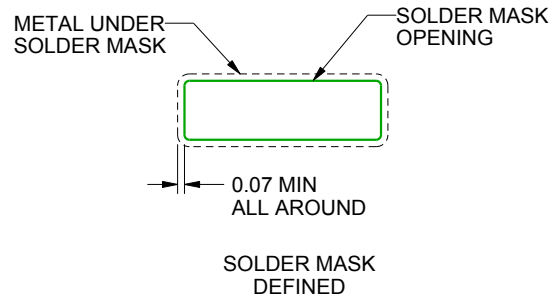
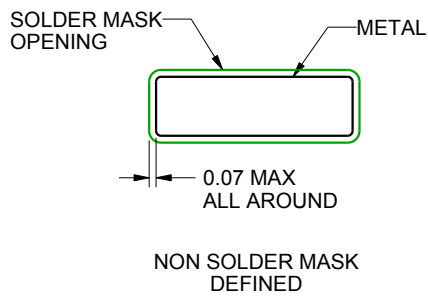

SOLDER MASK DETAILS

4220724/A 05/2016

NOTES: (continued)

- 6. Publication IPC-7351 may have alternate designs.
- 7. Solder mask tolerances between and around signal pads can vary based on board fabrication site.

EXAMPLE STENCIL DESIGN

DW0020A

SOIC - 2.65 mm max height

SOIC

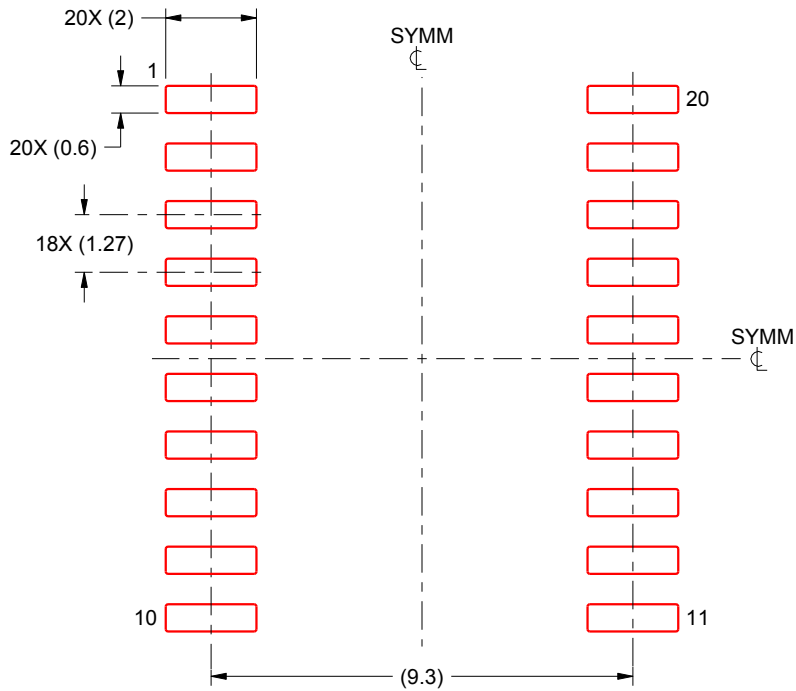

SOLDER PASTE EXAMPLE
BASED ON 0.125 mm THICK STENCIL
SCALE:6X

4220724/A 05/2016

NOTES: (continued)

8. Laser cutting apertures with trapezoidal walls and rounded corners may offer better paste release. IPC-7525 may have alternate design recommendations.
9. Board assembly site may have different recommendations for stencil design.

IMPORTANT NOTICE AND DISCLAIMER

TI PROVIDES TECHNICAL AND RELIABILITY DATA (INCLUDING DATA SHEETS), DESIGN RESOURCES (INCLUDING REFERENCE DESIGNS), APPLICATION OR OTHER DESIGN ADVICE, WEB TOOLS, SAFETY INFORMATION, AND OTHER RESOURCES "AS IS" AND WITH ALL FAULTS, AND DISCLAIMS ALL WARRANTIES, EXPRESS AND IMPLIED, INCLUDING WITHOUT LIMITATION ANY IMPLIED WARRANTIES OF MERCHANTABILITY, FITNESS FOR A PARTICULAR PURPOSE OR NON-INFRINGEMENT OF THIRD PARTY INTELLECTUAL PROPERTY RIGHTS.

These resources are intended for skilled developers designing with TI products. You are solely responsible for (1) selecting the appropriate TI products for your application, (2) designing, validating and testing your application, and (3) ensuring your application meets applicable standards, and any other safety, security, regulatory or other requirements.

These resources are subject to change without notice. TI grants you permission to use these resources only for development of an application that uses the TI products described in the resource. Other reproduction and display of these resources is prohibited. No license is granted to any other TI intellectual property right or to any third party intellectual property right. TI disclaims responsibility for, and you will fully indemnify TI and its representatives against, any claims, damages, costs, losses, and liabilities arising out of your use of these resources.

TI's products are provided subject to [TI's Terms of Sale](#) or other applicable terms available either on ti.com or provided in conjunction with such TI products. TI's provision of these resources does not expand or otherwise alter TI's applicable warranties or warranty disclaimers for TI products.

TI objects to and rejects any additional or different terms you may have proposed.

Mailing Address: Texas Instruments, Post Office Box 655303, Dallas, Texas 75265
Copyright © 2022, Texas Instruments Incorporated