

## MSP430FR2422 混合信号微控制器

### 1 特性

- 嵌入式微控制器
  - 16 位 RISC 架构
  - 支持的时钟频率最高可达 16MHz
  - 1.8V 至 3.6V 的宽电源电压范围 (最低电源电压受限于 SVS 电平, 请参阅 [SVS 规格](#))
- 优化的超低功耗模式
  - 工作模式: 120 $\mu$ A/MHz (典型值)
  - 待机: 采用 32768Hz 晶振的 LPM3.5 实时时钟 (RTC) 计数器: 710nA (典型值)
  - 关断 (LPM4.5): 36nA, 未使用 SVS
- 低功耗铁电 RAM (FRAM)
  - 非易失性存储器容量高达 7.5KB
  - 内置错误修正码 (ECC)
  - 可配置的写保护
  - 对程序、常量和存储的统一存储
  - 耐写次数达 10<sup>15</sup> 次
  - 抗辐射和非磁性
  - FRAM 与 SRAM 之比高达 4:1
- 高性能模拟
  - 高达 8 通道 10 位模数转换器 (ADC)
    - 1.5V 的内部基准电压
    - 采样保持 200ksps
- 智能数字外设
  - 两个 16 位计时器, 每个计时器有三个捕捉/比较寄存器 (Timer\_A3)
  - 一个仅用作计数器的 16 位 RTC
  - 16 位循环冗余校验 (CRC)
- 增强型串行通信, 支持引脚重映射功能 (请参阅 [器件比较](#))
  - 一个 eUSCI\_A 接口, 支持 UART、IrDA 和 SPI
- 一个 eUSCI\_B 接口, 支持 SPI 和 I<sup>2</sup>C
- 时钟系统 (CS)
  - 片上 32kHz RC 振荡器 (REFO)
  - 带有锁频环 (FLL) 的片上 16MHz 数控振荡器 (DCO)
    - 室温下的精度为  $\pm 1\%$  (具有片上基准)
  - 片上超低频 10kHz 振荡器 (VLO)
  - 片上高频调制振荡器 (MODOSC)
  - 外部 32kHz 晶振 (LFXT)
  - 可编程 MCLK 预分频器 (1 至 128)
  - 通过可编程预分频器 (1、2、4 或 8) 从 MCLK 获得的 SMCLK
- 通用输入/输出和引脚功能
  - 共计 15 个 I/O (采用 VQFN-20 封装)
  - 15 个中断引脚 (P1 和 P2) 可以将 MCU 从低功耗模式下唤醒
- 开发工具和软件
  - 开发工具
    - 目标开发板 [MSP-TS430RHL20](#)
- 系列成员 (另请参阅 [器件比较](#))
  - MSP430FR2422 : 7.25KB 程序 FRAM、256B 信息 FRAM、2KB RAM
- 封装选项
  - 20 引脚: VQFN (RHL)
  - 16 引脚: TSSOP (PW)

### 2 应用

- 工业传感器
- 电池组
- 便携式电器
- 电动牙刷
- 低功耗医疗、健康和健身器材

### 3 说明

MSP430FR2422 是 MSP430™ 超值系列微控制器 (MCU) 产品组合的其中一个器件, 该超值系列微控制器是 TI 成本超低的 MCU 系列, 适用于感应和测量应用。MSP430FR2422 MCU 可提供 8KB 非易失性存储器并配备 8 通道 10 位 ADC。该架构、FRAM 和集成外设与多种低功耗模式相结合, 针对在便携式和电池供电传感应用中延长电池寿命进行了优化。采用 16 引脚 TSSOP 或 20 引脚 VQFN 封装。

TI 的 MSP430 超低功耗 FRAM 微控制器平台将独特的嵌入式 FRAM 和全面的超低功耗系统架构相结合, 从而使系统设计人员能够在降低能耗的同时提升性能。FRAM 技术兼有 RAM 的低功耗快速写入、灵活性、耐用性和闪存非易失性等特性。

MSP430FR2422 MCU 由广泛的硬件和软件生态系统进行支持, 提供参考设计和代码示例, 协助用户快速开展设计。开发套件包括 [MSP-TS430RHL20](#) 20 引脚目标开发板。TI 还提供免费的 [MSP430Ware™](#) 软件, 该软件以 [Code Composer Studio™ IDE](#) 桌面和云版本组件的形式提供 (位于 [TI Resource Explorer](#) 中)。E2E™ 支持论坛还为 MSP430 MCU 提供广泛的在线配套资料、培训和在线支持。

有关完整的模块说明, 请参阅 [《MSP430FR4xx 和 MSP430FR2xx 系列器件用户指南》](#)。



## 器件信息

器件型号 <sup>(1)</sup>	封装	封装尺寸 <sup>(2)</sup>
MSP430FR2422IPW16	TSSOP (16)	5mm × 4.4mm
MSP430FR2422IRHL	VQFN (20)	4.5mm × 3.5mm

- (1) 要获得最新的产品、封装和订购信息，请参阅节 12 中的 *封装选项附录*，或者访问德州仪器 (TI) 网站 [www.ti.com.cn](http://www.ti.com.cn)。
- (2) 这里显示的尺寸为近似值。要获得包含误差值的封装尺寸，请参阅 *机械数据* (节 12 中)。

## CAUTION

系统级静电放电 (ESD) 保护必须符合器件级 ESD 规范，以防发生电气过载或对数据或代码存储器造成干扰。如需更多信息，请参阅《MSP430 系统级 ESD 注意事项》。

## 4 功能方框图

图 4-1 给出了功能方框图。



图 4-1. 功能方框图

- MCU 的主电源对 DVCC 和 DVSS 分别为数字模块和模拟模块供电。推荐的旁路电容和去耦电容分别为  $4.7 \mu\text{F}$  至  $10 \mu\text{F}$  和  $0.1 \mu\text{F}$ ，精度为  $\pm 5\%$ 。
- P1 和 P2 特有引脚中断功能，可将 MCU 从所有 LPM 唤醒（包括 LPM3.5 和 LPM4）。
- 每个 Timer\_A3 具有 3 个捕捉/比较寄存器，不过仅 CCR1 和 CCR2 从外部连接。CCR0 寄存器仅用于内部周期时序和生成中断。
- 在 LPM3.5 模式下，RTC 模块可在其他外设停止工作的情况下继续工作。

## Table of Contents

<b>1 特性</b> .....	1	8.12 Timing and Switching Characteristics.....	19
<b>2 应用</b> .....	1	<b>9 Detailed Description</b> .....	39
<b>3 说明</b> .....	1	9.1 Overview.....	39
<b>4 功能方框图</b> .....	3	9.2 CPU.....	39
<b>5 Revision History</b> .....	5	9.3 Operating Modes.....	39
<b>6 Device Comparison</b> .....	7	9.4 Interrupt Vector Addresses.....	41
6.1 Related Products.....	7	9.5 Bootloader (BSL).....	42
<b>7 Terminal Configuration and Functions</b> .....	8	9.6 JTAG Standard Interface.....	42
7.1 Pin Diagrams.....	8	9.7 Spy-Bi-Wire Interface (SBW).....	43
7.2 Pin Attributes.....	9	9.8 FRAM.....	43
7.3 Signal Descriptions.....	11	9.9 Memory Protection.....	43
7.4 Pin Multiplexing.....	13	9.10 Peripherals.....	43
7.5 Buffer Types.....	13	9.11 Input/Output Diagrams.....	52
7.6 Connection of Unused Pins.....	13	9.12 Device Descriptors.....	56
<b>8 Specifications</b> .....	14	9.13 Memory.....	57
8.1 Absolute Maximum Ratings.....	14	9.14 Identification.....	65
8.2 ESD Ratings.....	14	<b>10 Applications, Implementation, and Layout</b> .....	66
8.3 Recommended Operating Conditions.....	14	10.1 Device Connection and Layout Fundamentals.....	66
8.4 Active Mode Supply Current Into $V_{CC}$ Excluding External Current.....	15	10.2 Peripheral- and Interface-Specific Design Information.....	69
8.5 Active Mode Supply Current Per MHz.....	15	<b>11 Device and Documentation Support</b> .....	71
8.6 Low-Power Mode (LPM0) Supply Currents Into $V_{CC}$ Excluding External Current.....	15	11.1 Getting Started and Next Steps.....	71
8.7 Low-Power Mode (LPM3, LPM4) Supply Currents (Into $V_{CC}$ ) Excluding External Current.....	16	11.2 Device Nomenclature.....	71
8.8 Low-Power Mode (LPMx.5) Supply Currents (Into $V_{CC}$ ) Excluding External Current.....	17	11.3 Tools and Software.....	72
8.9 Typical Characteristics - Low-Power Mode Supply Currents.....	18	11.4 Documentation Support.....	74
8.10 Typical Characteristics - Current Consumption Per Module.....	18	11.5 支持资源.....	75
8.11 Thermal Resistance Characteristics.....	19	11.6 Trademarks.....	75
		11.7 静电放电警告.....	75
		11.8 Export Control Notice.....	75
		11.9 术语表.....	75
		<b>12 Mechanical, Packaging, and Orderable Information</b> .....	76

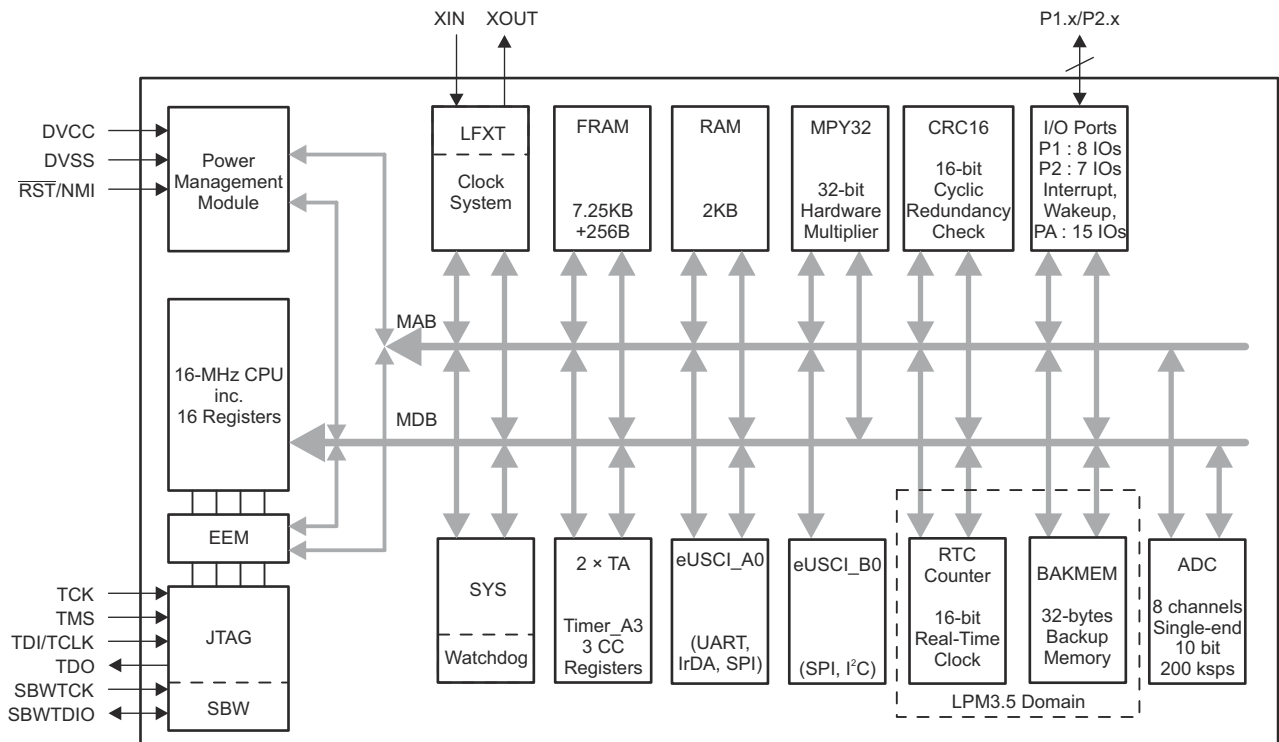
## 5 Revision History

注：以前版本的页码可能与当前版本的页码不同

Changes from revision C to revision D

Changes from December 11, 2019 to January 29, 2021	Page
• 更新了整个文档中的表格、图和交叉参考的编号格式.....	1
• Added the TMS signal to pin 12 in <a href="#">图 7-2, 16-Pin PW Package (Top View)</a> .....	8
• Corrected the assignments for TA0.2 and TA0.1 for RHL pins 16 and 17 and PW pins 12 and 13 in <a href="#">表 7-1, Pin Attributes</a> .....	9

Changes from revision B to revision C

Changes from August 20, 2019 to December 10, 2019	Page
• Changed the note that begins "Supply voltage changes faster than 0.2 V/ $\mu$ s can trigger a BOR reset..." in <a href="#">节 8.3, Recommended Operating Conditions</a> .....	14
• Added the note that begins "TI recommends that power to the DVCC pin must not exceed the limits..." in <a href="#">节 8.3, Recommended Operating Conditions</a> .....	14
• Changed the note that begins "A capacitor tolerance of $\pm 20\%$ or better is required..." in <a href="#">节 8.3, Recommended Operating Conditions</a> .....	14
• Added the note "See <a href="#">MSP430 32-kHz Crystal Oscillators</a> for details on crystal section, layout, and testing" to <a href="#">节 8.12.3.1, XT1 Crystal Oscillator (Low Frequency)</a> .....	21
• Changed the note that begins "Requires external capacitors at both terminals..." in <a href="#">节 8.12.3.1, XT1 Crystal Oscillator (Low Frequency)</a> .....	21
• Corrected the test conditions for the $R_I$ parameter in <a href="#">节 8.12.8.1, ADC, Power Supply and Input Range Conditions</a> .....	34
• Added the note that begins " $t_{\text{Sample}} = \ln(2^{n+1}) \times \tau$ ..." in <a href="#">节 8.12.8.2, ADC, 10-Bit Timing Parameters</a> .....	34
• Added "1.5-V reference factor" in <a href="#">表 9-18, Device Descriptors</a> .....	56
• Changed the CRC covered end address to 0x1AF5 in note (1) in <a href="#">表 9-18, Device Descriptors</a> .....	56

Changes from revision A to revision B

Changes from November 8, 2018 to August 19, 2019	Page
• 更新了 <a href="#">节 1 特性</a> .....	1
• Changed CapTIvate BSWP demonstration board to CapTIvate phone demonstration board in note (11) on <a href="#">节 8.7, Low-Power Mode (LPM3, LPM4) Supply Currents (Into <math>V_{CC}</math>) Excluding External Current</a> .....	16
• Changed CapTIvate BSWP demonstration board to CapTIvate phone demonstration board in note (19) on <a href="#">节 8.7, Low-Power Mode (LPM3, LPM4) Supply Currents (Into <math>V_{CC}</math>) Excluding External Current</a> .....	16
• Updated <a href="#">节 11.2, Device Nomenclature</a> .....	71

Changes from initial release to revision A

Changes from January 12, 2018 to November 7, 2018	Page
• 更改了 <a href="#">节 1 特性</a> 中的列表项 "1.8V 至 3.6V 的宽电源电压范围..." .....	1
• Updated <a href="#">节 6.1, Related Products</a> .....	7
• Changed HBM limit to $\pm 1000$ V and CDM limit to $\pm 250$ V in <a href="#">节 8.2, ESD Ratings</a> .....	14
• Changed the MIN value of the $V_{CC}$ parameter from 2 V to 1.8 V in <a href="#">节 8.3, Recommended Operating Conditions</a> .....	14
• Changed the crystal in the footnote that begins "Characterized with a Seiko Crystal SC-32S crystal..." in <a href="#">节 8.7, Low-Power Mode (LPM3, LPM4) Supply Currents (Into <math>V_{CC}</math>) Excluding External Current</a> .....	16

---

- Changed the crystal in the footnote that begins "Characterized with a Seiko Crystal SC-32S crystal..." in [节 8.8, Low-Power Mode \(LPMx.5\) Supply Currents \(Into  \$V\_{CC}\$ \) Excluding External Current](#) ..... 17
- Added note on  $V_{SVSH-}$  and  $V_{SVSH+}$  parameters to [节 8.12.1.1, PMM, SVS and BOR](#) ..... 19
- Changed the minimum  $V_{CC}$  from 2.0 V to 1.8 V in the test conditions for the  $f_{REFO}$ ,  $df_{REFO}/dV_{CC}$ , and  $f_{DC}$  parameters and in note (2) in [节 8.12.3.4, REFO](#) ..... 22
- Changed the minimum  $V_{CC}$  from 2.0 V to 1.8 V in the test conditions for the  $df_{VLO}/dV_{CC}$  parameter and in note (2) in [节 8.12.3.5, Internal Very-Low-Power Low-Frequency Oscillator \(VLO\)](#) ..... 24
- Changed the minimum  $V_{CC}$  from 2.0 V to 1.8 V in the test conditions for the  $f_{MODOSC}/dV_{CC}$  parameter in [节 8.12.3.6, Module Oscillator \(MODOSC\)](#) ..... 24
- Corrected bitfield from RTCCLK to RTCCKSEL in table note that starts "Controlled by ..." in [表 9-8, Clock Distribution](#) ..... 44
- Corrected bitfield from IRDSEL to IRDSSEL in [节 9.10.8, Timers \(Timer0\\_A3, Timer1\\_A3\)](#), in the description that starts "The interconnection of Timer0\_A3 and ..." ..... 49
- Corrected ADCINCHx column heading in [表 9-13, ADC Channel Connections](#) ..... 50
- Added P1SELC information in [表 9-28, Port P1, P2 Registers \(Base Address: 0200h\)](#) ..... 58
- Added P2SELC information in [表 9-28, Port P1, P2 Registers \(Base Address: 0200h\)](#) ..... 58

---

## 6 Device Comparison

表 6-1 summarizes the features of the available family members.

**表 6-1. Device Comparison**

DEVICE <sup>(1)</sup>	PROGRAM FRAM + INFORMATION FRAM (bytes)	SRAM (bytes)	TA0,TA1	eUSCI_A	eUSCI_B	10-BIT ADC CHANNELS	GPIOs	PACKAGE <sup>(2)</sup>
MSP430FR2422IRHL	7424 + 256	2048	2, 3 × CCR <sup>(3)</sup>	1	1	8	15	20 RHL (VQFN)
MSP430FR2422IPW16	7424 + 256	2048	2, 3 × CCR <sup>(3)</sup>	1	1	5	11	16 PW (TSSOP)

- (1) For the most current package and ordering information, see the *Package Option Addendum* in 节 12, or see the TI website at [www.ti.com](http://www.ti.com).
- (2) Package drawings, standard packing quantities, thermal data, symbolization, and PCB design guidelines are available at [www.ti.com/packaging](http://www.ti.com/packaging).
- (3) A CCR register is a configurable register that provides internal and external capture or compare inputs, or internal and external PWM outputs.

### 6.1 Related Products

For information about other devices in this family of products or related products, see the following links.

[TI 16-bit and 32-bit microcontrollers](#)

High-performance, low-power solutions to enable the autonomous future

[Products for MSP430 ultra-low-power sensing and measurement microcontrollers](#)

One platform. One ecosystem. Endless possibilities.

[Companion Products for MSP430FR2422](#)

Review products that are frequently purchased or used in conjunction with this product.

[Reference Designs](#)

Find reference designs leveraging the best in TI technology to solve your system-level challenges

## 7 Terminal Configuration and Functions

### 7.1 Pin Diagrams

图 7-1 shows the pinout of the 20-pin RHL package.



图 7-1. 20-Pin RHL Package (Top View)

图 7-2 shows the pinout of the 16-pin PW package.

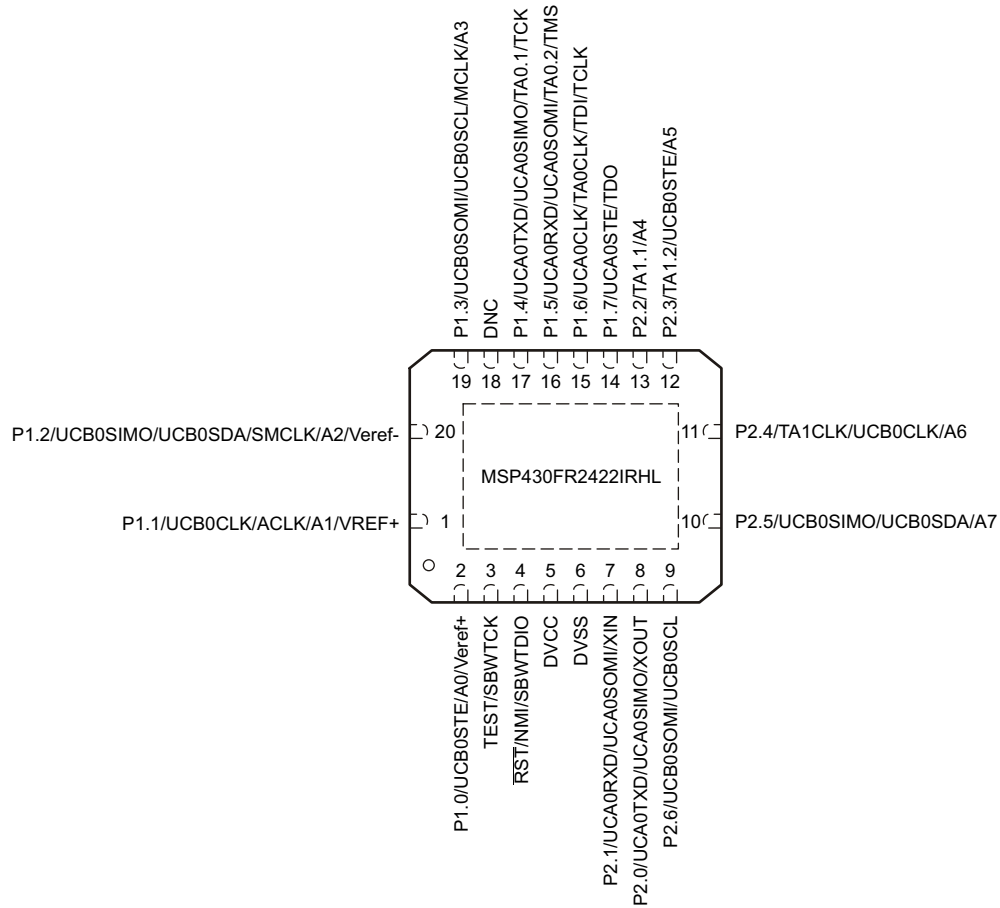

图 7-2. 16-Pin PW Package (Top View)

## 7.2 Pin Attributes

表 7-1 lists the attributes of all pins.

表 7-1. Pin Attributes

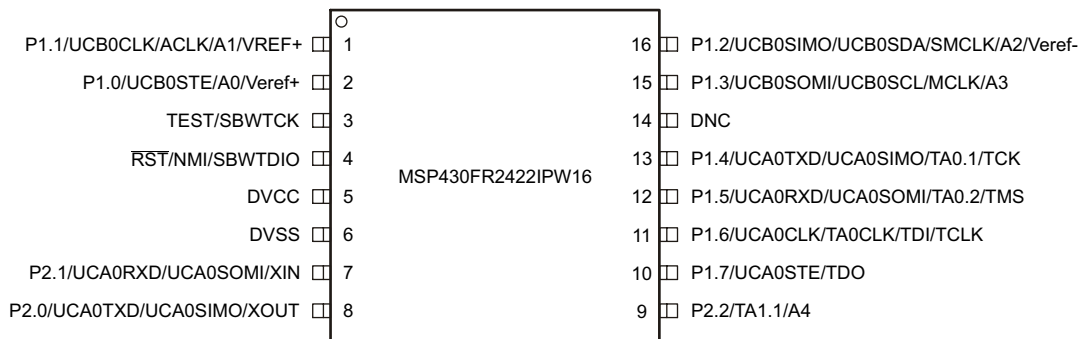
PIN NUMBER		SIGNAL NAME <sup>(1) (4)</sup>	SIGNAL TYPE <sup>(2)</sup>	BUFFER TYPE <sup>(3)</sup>	POWER SOURCE <sup>(5)</sup>	RESET STATE AFTER BOR <sup>(6)</sup>
RHL	PW16					
1	1	P1.1 (RD)	I/O	LVC MOS	DVCC	OFF
		UCB0CLK	I/O	LVC MOS	DVCC	-
		ACLK	I/O	LVC MOS	DVCC	-
		A1	I	Analog	DVCC	-
		VREF+	I	Analog	Power	-
2	2	P1.0 (RD)	I/O	LVC MOS	DVCC	OFF
		UCB0STE	I/O	LVC MOS	DVCC	-
		A0	I	Analog	DVCC	-
		Veref+	I	Analog	Power	-
3	3	TEST (RD)	I	LVC MOS	DVCC	OFF
		SBWTCK	I	LVC MOS	DVCC	-
4	4	RST (RD)	I	LVC MOS	DVCC	OFF
		NMI	I	LVC MOS	DVCC	-
		SBWTDIO	I/O	LVC MOS	DVCC	-
5	5	DVCC	P	Power	DVCC	N/A
6	6	DVSS	P	Power	DVCC	N/A
7	7	P2.1 (RD)	I/O	LVC MOS	DVCC	OFF
		UCA0RXD	I	LVC MOS	DVCC	-
		UCA0SOMI	I/O	LVC MOS	DVCC	-
		XIN	I	LVC MOS	DVCC	-
8	8	P2.0 (RD)	I/O	LVC MOS	DVCC	OFF
		UCA0TXD	O	LVC MOS	DVCC	-
		UCA0SIMO	I/O	LVC MOS	DVCC	-
		XOUT	O	LVC MOS	DVCC	-
9	-	P2.6 (RD)	I/O	LVC MOS	DVCC	OFF
		UCB0SOMI	I/O	LVC MOS	DVCC	-
		UCB0SCL	I/O	LVC MOS	DVCC	-
10	-	P2.5 (RD)	I/O	LVC MOS	DVCC	OFF
		UCB0SIMO	I/O	LVC MOS	DVCC	-
		UCB0SDA	I/O	LVC MOS	DVCC	-
		A7	I	Analog	DVCC	-
11	-	P2.4 (RD)	I/O	LVC MOS	DVCC	OFF
		TA1CLK	I	LVC MOS	DVCC	-
		UCB0CLK	I/O	LVC MOS	DVCC	-
		A6	I	Analog	DVCC	-
12	-	P2.3 (RD)	I/O	LVC MOS	DVCC	OFF
		TA1.2	I/O	LVC MOS	DVCC	-
		UCB0STE	I/O	LVC MOS	DVCC	-
		A5	I	Analog	DVCC	-

表 7-1. Pin Attributes (continued)

PIN NUMBER		SIGNAL NAME <sup>(1)</sup> (4)	SIGNAL TYPE <sup>(2)</sup>	BUFFER TYPE <sup>(3)</sup>	POWER SOURCE <sup>(5)</sup>	RESET STATE AFTER BOR <sup>(6)</sup>
RHL	PW16					
13	9	P2.2 (RD)	I/O	LVC MOS	DVCC	OFF
		TA1.1	I/O	LVC MOS	DVCC	-
		A4	I	Analog	DVCC	-
14	10	P1.7 (RD)	I/O	LVC MOS	DVCC	OFF
		UCA0STE	I/O	LVC MOS	DVCC	-
		TDO	O	LVC MOS	DVCC	-
15	11	P1.6 (RD)	I/O	LVC MOS	DVCC	OFF
		UCA0CLK	I/O	LVC MOS	DVCC	-
		TA0CLK	I	LVC MOS	DVCC	-
		TDI	I	LVC MOS	DVCC	-
		TCLK	I	LVC MOS	DVCC	-
16	12	P1.5 (RD)	I/O	LVC MOS	DVCC	OFF
		UCA0RXD	I	LVC MOS	DVCC	-
		UCA0SOMI	I/O	LVC MOS	DVCC	-
		TA0.2	I/O	LVC MOS	DVCC	-
		TMS	I	LVC MOS	DVCC	-
17	13	P1.4 (RD)	I/O	LVC MOS	DVCC	OFF
		UCA0TXD	O	LVC MOS	DVCC	-
		UCA0SIMO	I/O	LVC MOS	DVCC	-
		TA0.1	I/O	LVC MOS	DVCC	-
		TCK	I	LVC MOS	DVCC	-
18	14	DNC	-	-	-	-
19	15	P1.3 (RD)	I/O	LVC MOS	DVCC	OFF
		UCB0SOMI	I/O	LVC MOS	DVCC	-
		UCB0SCL	I/O	LVC MOS	DVCC	-
		MCLK	O	LVC MOS	DVCC	-
		A3	I	Analog	DVCC	-
20	16	P1.2 (RD)	I/O	LVC MOS	DVCC	OFF
		UCB0SIMO	I/O	LVC MOS	DVCC	-
		UCB0SDA	I/O	LVC MOS	DVCC	-
		SMCLK	O	LVC MOS	DVCC	-
		A2	I	Analog	DVCC	-
		Verif-	I	Analog	Power	-

(1) Signals names with (RD) denote the reset default pin name.

(2) Signal Types: I = Input, O = Output, I/O = Input or Output

(3) Buffer Types: LVC MOS, Analog, or Power (see 表 7-3)

(4) To determine the pin mux encodings for each pin, see 节 9.11.

(5) The power source shown in this table is the I/O power source, which may differ from the module power source.

(6) Reset States:

OFF = High-impedance with Schmitt trigger and pullup or pulldown (if available) disabled

N/A = Not applicable

## 7.3 Signal Descriptions

表 7-2 describes the signals for all device variants and package options.

表 7-2. Signal Descriptions

FUNCTION	SIGNAL NAME	PIN NUMBER		PIN TYPE <sup>(1)</sup>	DESCRIPTION
		RHL	PW		
ADC	A0	2	2	I	Analog input A0
	A1	1	1	I	Analog input A1
	A2	20	16	I	Analog input A2
	A3	19	15	I	Analog input A3
	A4	13	9	I	Analog input A4
	A5	12	-	I	Analog input A5
	A6	11	-	I	Analog input A6
	A7	10	-	I	Analog input A7
	Veref+	2	2	I	ADC positive reference
	Veref-	20	16	I	ADC negative reference
Clock	ACLK	1	1	I/O	ACLK output
	MCLK	19	15	O	MCLK output
	SMCLK	20	16	O	SMCLK output
	XIN	7	7	I	Input terminal for crystal oscillator
	XOUT	8	8	O	Output terminal for crystal oscillator
Debug	SBWTCK	3	3	I	Spy-Bi-Wire input clock
	SBWTDIO	4	4	I/O	Spy-Bi-Wire data input/output
	TCK	17	13	I	Test clock
	TCLK	15	11	I	Test clock input
	TDI	15	11	I	Test data input
	TDO	14	10	O	Test data output
	TEST	3	3	I	Test mode pin - selected digital I/O on JTAG pins
	TMS	16	12	I	Test mode select
GPIO	P1.0	2	2	I/O	General-purpose I/O
	P1.1	1	1	I/O	General-purpose I/O
	P1.2	20	16	I/O	General-purpose I/O
	P1.3	19	15	I/O	General-purpose I/O
	P1.4	17	13	I/O	General-purpose I/O <sup>(4)</sup>
	P1.5	16	12	I/O	General-purpose I/O <sup>(4)</sup>
	P1.6	15	11	I/O	General-purpose I/O <sup>(4)</sup>
	P1.7	14	10	I/O	General-purpose I/O <sup>(4)</sup>
	P2.0	8	8	I/O	General-purpose I/O
	P2.1	7	7	I/O	General-purpose I/O
	P2.2	13	9	I/O	General-purpose I/O
	P2.3	12	-	I/O	General-purpose I/O
	P2.4	11	-	I/O	General-purpose I/O
	P2.5	10	-	I/O	General-purpose I/O
	P2.6	9	-	I/O	General-purpose I/O

表 7-2. Signal Descriptions (continued)

FUNCTION	SIGNAL NAME	PIN NUMBER		PIN TYPE <sup>(1)</sup>	DESCRIPTION	
		RHL	PW			
I <sup>2</sup> C	UCB0SCL <sup>(2)</sup>	19	15	I/O	eUSCI_B0 I <sup>2</sup> C clock	
	UCB0SDA <sup>(2)</sup>	20	16	I/O	eUSCI_B0 I <sup>2</sup> C data	
	UCB0SCL <sup>(2)</sup>	9	-	I/O	eUSCI_B0 I <sup>2</sup> C clock	
	UCB0SDA <sup>(2)</sup>	10	-	I/O	eUSCI_B0 I <sup>2</sup> C data	
Power	DVCC	5	5	P	Power supply	
	DVSS	6	6	P	Power ground	
	VREF+	1	1	P	Output of positive reference voltage with ground as reference	
SPI	UCA0STE	14	10	I/O	eUSCI_A0 SPI slave transmit enable	
	UCA0CLK	15	11	I/O	eUSCI_A0 SPI clock input/output	
	UCA0SOMI <sup>(2) (3)</sup>	16	12	I/O	eUSCI_A0 SPI slave out/master in	
	UCA0SIMO <sup>(2) (3)</sup>	17	13	I/O	eUSCI_A0 SPI slave in/master out	
	UCA0SOMI <sup>(2) (3)</sup>	7	7	I/O	eUSCI_A0 SPI slave out/master in	
	UCA0SIMO <sup>(2) (3)</sup>	8	8	I/O	eUSCI_A0 SPI slave in/master out	
	UCB0STE <sup>(2)</sup>	2	2	I/O	eUSCI_B0 slave transmit enable	
	UCB0CLK <sup>(2)</sup>	1	1	I/O	eUSCI_B0 clock input/output	
	UCB0SOMI <sup>(2)</sup>	19	15	I/O	eUSCI_B0 SPI slave out/master in	
	UCB0SIMO <sup>(2)</sup>	20	16	I/O	eUSCI_B0 SPI slave in/master out	
	UCB0STE <sup>(2)</sup>	12	-	I/O	eUSCI_B0 slave transmit enable	
	UCB0CLK <sup>(2)</sup>	11	-	I/O	eUSCI_B0 clock input/output	
	UCB0SOMI <sup>(2)</sup>	9	-	I/O	eUSCI_B0 SPI slave out/master in	
	UCB0SIMO <sup>(2)</sup>	10	-	I/O	eUSCI_B0 SPI slave in/master out	
	System	NMI	4	4	I	Nonmaskable interrupt input
		RST	4	4	I	Active-low reset input
Timer_A	TA0.1	17	13	I/O	Timer TA0 CCR1 capture: CCI1A input, compare: Out1 outputs	
	TA0.2	16	12	I/O	Timer TA0 CCR2 capture: CCI2A input, compare: Out2 outputs	
	TA0CLK	15	11	I	Timer clock input TACLK for TA0	
	TA1.1	13	9	I/O	Timer TA1 CCR1 capture: CCI1A input, compare: Out1 outputs	
	TA1.2	12	-	I/O	Timer TA1 CCR2 capture: CCI2A input, compare: Out2 outputs	
	TA1CLK	11	-	I	Timer clock input TACLK for TA1	
UART	UCA0RXD <sup>(2)</sup>	16	12	I	eUSCI_A0 UART receive data	
	UCA0TXD <sup>(2)</sup>	17	13	O	eUSCI_A0 UART transmit data	
	UCA0RXD <sup>(2)</sup>	7	7	I	eUSCI_A0 UART receive data	
	UCA0TXD <sup>(2)</sup>	8	8	O	eUSCI_A0 UART transmit data	
DNC	Do not connect	18	14	-	Do not connect	
QFN Pad	QFN thermal pad	Pad	-	-	QFN package exposed thermal pad. TI recommends connecting to V <sub>SS</sub> .	

(1) Pin Types: I = Input, O = Output, I/O = Input or Output, P = Power

(2) These signal assignments are controlled by the USCIARMP bit of the SYSCFG3 register or the USCIBRMP bit of the SYSCFG2 register. Only one group can be selected at one time.

(3) Signal assignments on these pins are controlled by the remap functionality and are selected by the USCIARMP bit in the SYSCFG3 register. Only one group can be selected at one time. The CLK and STE assignments are fixed and shared by both SPI function groups.

(4) Because this pin is multiplexed with the JTAG function, TI recommends disabling the pin interrupt function while in JTAG debug to prevent collisions.

## 7.4 Pin Multiplexing

Pin multiplexing for this MCU is controlled by both register settings and operating modes (for example, if the MCU is in test mode). For details of the settings for each pin and diagrams of the multiplexed ports, see [节 9.11](#).

## 7.5 Buffer Types

[表 7-3](#) defines the pin buffer types that are listed in [表 7-1](#)

**表 7-3. Buffer Types**

BUFFER TYPE (STANDARD)	NOMINAL VOLTAGE	HYSTERESIS	PU OR PD	NOMINAL PU OR PD STRENGTH ( $\mu$ A)	OUTPUT DRIVE STRENGTH (mA)	OTHER CHARACTERISTICS
LVC MOS	3.0 V	Y <sup>(1)</sup>	Programmable	See <a href="#">节 8.12.4</a>	See <a href="#">节 8.12.4</a>	
Analog	3.0 V	N	N/A	N/A	N/A	See analog modules in <a href="#">节 8</a> for details.
Power (DVCC)	3.0 V	N	N/A	N/A	N/A	SVS enables hysteresis on DVCC.
Power (AVCC)	3.0 V	N	N/A	N/A	N/A	

(1) Only for input pins.

## 7.6 Connection of Unused Pins

[表 7-4](#) lists the correct termination of unused pins.

**表 7-4. Connection of Unused Pins**

PIN <sup>(1)</sup>	POTENTIAL	COMMENT
Px.0 to Px.7	Open	Switched to port function, output direction (PxDIR.n = 1)
RST/NMI	DV <sub>CC</sub>	47-k $\Omega$ pullup or internal pullup selected with 10-nF (or 1.1-nF) pulldown <sup>(2)</sup>
TEST	Open	This pin always has an internal pull-down enabled.

- (1) Any unused pin with a secondary function that is shared with general-purpose I/O should follow the Px.0 to Px.7 unused pin connection guidelines.
- (2) The pulldown capacitor should not exceed 1.1 nF when using MCUs with Spy-Bi-Wire interface in Spy-Bi-Wire mode with TI tools like FET interfaces or GANG programmers.

## 8 Specifications

### 8.1 Absolute Maximum Ratings

over operating free-air temperature range (unless otherwise noted)

(1)	MIN	MAX	UNIT
Voltage applied at DVCC pin to $V_{SS}$	- 0.3	4.1	V
Voltage applied to any other pin <sup>(2)</sup>	- 0.3	$V_{CC} + 0.3$ (4.1 V Max)	V
Diode current at any device pin		±2	mA
Maximum junction temperature, $T_J$		85	°C
Storage temperature, $T_{stg}$ <sup>(3)</sup>	- 40	125	°C

- (1) Stresses beyond those listed under *Absolute Maximum Ratings* may cause permanent damage to the device. These are stress ratings only, and functional operation of the device at these or any other conditions beyond those indicated under *Recommended Operating Conditions* is not implied. Exposure to absolute-maximum-rated conditions for extended periods may affect device reliability.
- (2) All voltages referenced to  $V_{SS}$ .
- (3) Higher temperature may be applied during board soldering according to the current JEDEC J-STD-020 specification with peak reflow temperatures not higher than classified on the device label on the shipping boxes or reels.

### 8.2 ESD Ratings

		VALUE	UNIT
$V_{(ESD)}$ Electrostatic discharge	Human-body model (HBM), per ANSI/ESDA/JEDEC JS-001 <sup>(1)</sup>	±1000	V
	Charged-device model (CDM), per JEDEC specification JESD22-C101 <sup>(2)</sup>	±250	

- (1) JEDEC document JEP155 states that 500-V HBM allows safe manufacturing with a standard ESD control process. Pins listed as ±1000 V may actually have higher performance.
- (2) JEDEC document JEP157 states that 250-V CDM allows safe manufacturing with a standard ESD control process. Pins listed as ±250 V may actually have higher performance.

### 8.3 Recommended Operating Conditions

		MIN	NOM	MAX	UNIT
$V_{CC}$	Supply voltage applied at DVCC pin <sup>(1) (2) (3) (4)</sup>	1.8		3.6	V
$V_{SS}$	Supply voltage applied at DVSS pin		0		V
$T_A$	Operating free-air temperature	- 40		85	°C
$T_J$	Operating junction temperature	- 40		85	°C
$C_{DVCC}$	Recommended capacitor at DVCC <sup>(5)</sup>	4.7	10		µF
$f_{SYSTEM}$	Processor frequency (maximum MCLK frequency) <sup>(4) (7)</sup>	No FRAM wait states (NWAITSx = 0)		8	MHz
		With FRAM wait states (NWAITSx = 1) <sup>(6)</sup>		16 <sup>(8)</sup>	
$f_{ACLK}$	Maximum ACLK frequency			40	kHz
$f_{SMCLK}$	Maximum SMCLK frequency			16 <sup>(8)</sup>	MHz

- (1) Supply voltage changes faster than 0.2 V/µs can trigger a BOR reset even within the recommended supply voltage range. Following the data sheet recommendation for capacitor  $C_{DVCC}$  limits the slopes accordingly.
- (2) Modules may have a different supply voltage range specification. See the specification of the respective module in this data sheet.
- (3) TI recommends that power to the DVCC pin must not exceed the limits specified in *Recommended Operating Conditions*. Exceeding the specified limits can cause malfunction of the device including erroneous writes to RAM and FRAM.
- (4) The minimum supply voltage is defined by the SVS levels. See the SVS threshold parameters in [§ 8.12.1.1](#).
- (5) A capacitor tolerance of ±20% or better is required. A low-ESR ceramic capacitor of 100 nF (minimum) should be placed as close as possible (within a few millimeters) to the respective pin pair.
- (6) Wait states only occur on actual FRAM accesses (that is, on FRAM cache misses). RAM and peripheral accesses are always executed without wait states.
- (7) Modules may have a different maximum input clock specification. See the specification of the respective module in this data sheet.
- (8) If clock sources such as HF crystals or the DCO with frequencies >16 MHz are used, the clock must be divided in the clock system to comply with this operating condition.

## 8.4 Active Mode Supply Current Into $V_{CC}$ Excluding External Current

See (1)

PARAMETER	EXECUTION MEMORY	TEST CONDITION	FREQUENCY ( $f_{MCLK} = f_{SMCLK}$ )						UNIT
			1 MHz 0 WAIT STATES (NWAITS <sub>x</sub> = 0)		8 MHz 0 WAIT STATES (NWAITS <sub>x</sub> = 0)		16 MHz 1 WAIT STATE (NWAITS <sub>x</sub> = 1)		
			TYP	MAX	TYP	MAX	TYP	MAX	
$I_{AM, FRAM(0\%)}$	FRAM 0% cache hit ratio	3 V, 25°C	454		2620		2935		$\mu A$
		3 V, 85°C	471		2700		2980 3250		
$I_{AM, FRAM(100\%)}$	FRAM 100% cache hit ratio	3 V, 25°C	191		573		950		$\mu A$
		3 V, 85°C	199		592		974 1200		
$I_{AM, RAM}^{(2)}$	RAM	3 V, 25°C	216		772		1300		$\mu A$

(1) All inputs are tied to 0 V or to  $V_{CC}$ . Outputs do not source or sink any current. Characterized with program executing typical data processing.

$f_{ACLK} = 32768$  Hz,  $f_{MCLK} = f_{SMCLK} = f_{DCO}$  at specified frequency  
Program and data entirely reside in FRAM. All execution is from FRAM.

(2) Program and data reside entirely in RAM. All execution is from RAM. No access to FRAM.

## 8.5 Active Mode Supply Current Per MHz

$V_{CC} = 3$  V,  $T_A = 25^\circ C$  (unless otherwise noted)

PARAMETER	TEST CONDITIONS	TYP	UNIT
$dI_{AM, FRAM}/df$	Active mode current consumption per MHz, execution from FRAM, no wait states	120	$\mu A/MHz$

## 8.6 Low-Power Mode (LPM0) Supply Currents Into $V_{CC}$ Excluding External Current

$V_{CC} = 3$  V,  $T_A = 25^\circ C$  (unless otherwise noted)<sup>(1) (2)</sup>

PARAMETER	$V_{CC}$	FREQUENCY ( $f_{SMCLK}$ )						UNIT
		1 MHz		8 MHz		16 MHz		
		TYP	MAX	TYP	MAX	TYP	MAX	
$I_{LPM0}$	2 V	145		292		395		$\mu A$
	3 V	155		300		394		

(1) All inputs are tied to 0 V or to  $V_{CC}$ . Outputs do not source or sink any current.

(2) Current for watchdog timer clocked by SMCLK included.

$f_{ACLK} = 32768$  Hz,  $f_{MCLK} = 0$  MHz,  $f_{SMCLK}$  at specified frequency.

## 8.7 Low-Power Mode (LPM3, LPM4) Supply Currents (Into $V_{CC}$ ) Excluding External Current

over recommended ranges of supply voltage and operating free-air temperature (unless otherwise noted) <sup>(1)</sup>

PARAMETER		$V_{CC}$	- 40°C		25°C		85°C		UNIT
			TYP	MAX	TYP	MAX	TYP	MAX	
$I_{LPM3,XT1}$	Low-power mode 3, 12.5-pF crystal, includes SVS <sup>(2) (3) (4)</sup>	3 V	0.96		1.11		2.75	6.2	$\mu$ A
		2 V	0.93		1.08		2.78		
$I_{LPM3,VLO}$	Low-power mode 3, VLO, excludes SVS <sup>(5)</sup>	3 V	0.77		0.92		2.66	6.0	$\mu$ A
		2 V	0.75		0.90		2.60		
$I_{LPM3,RTC}$	Low-power mode 3, RTC, excludes SVS <sup>(9)</sup>	3 V	0.90		1.05		2.77		$\mu$ A
$I_{LPM4,SVS}$	Low-power mode 4, includes SVS <sup>(6)</sup>	3 V	0.51		0.64		2.30		$\mu$ A
		2 V	0.49		0.61		2.25		
$I_{LPM4}$	Low-power mode 4, excludes SVS <sup>(6)</sup>	3 V	0.35		0.48		2.13		$\mu$ A
		2 V	0.34		0.46		2.10		
$I_{LPM4,VLO}$	Low-power mode 4, RTC is sourced from VLO, excludes SVS <sup>(7)</sup>	3 V	0.43		0.56		2.21		$\mu$ A
		2 V	0.42		0.55		2.19		
$I_{LPM4,XT1}$	Low-power mode 4, RTC is sourced from XT1, excludes SVS <sup>(8)</sup>	3 V	0.80		0.96		2.68		$\mu$ A
		2 V	0.79		0.94		2.64		

- (1) All inputs are tied to 0 V or to  $V_{CC}$ . Outputs do not source or sink any current.
- (2) Not applicable for MCUs with HF crystal oscillator only.
- (3) Characterized with a Seiko Crystal SC-32S crystal with a load capacitance chosen to closely match the required load.
- (4) Low-power mode 3, 12.5-pF crystal, includes SVS test conditions:  
Current for watchdog timer clocked by ACLK and RTC clocked by XT1 included. Current for brownout and SVS included (SVSHE = 1).  
CPUOFF = 1, SCG0 = 1 SCG1 = 1, OSCOFF = 0 (LPM3),  
 $f_{XT1} = 32768$  Hz,  $f_{ACLK} = f_{XT1}$ ,  $f_{MCLK} = f_{SMCLK} = 0$  MHz
- (5) Low-power mode 3, VLO, excludes SVS test conditions:  
Current for watchdog timer clocked by VLO included. RTC disabled. Current for brownout included. SVS disabled (SVSHE = 0).  
CPUOFF = 1, SCG0 = 1 SCG1 = 1, OSCOFF = 0 (LPM3)  
 $f_{XT1} = 32768$  Hz,  $f_{ACLK} = f_{MCLK} = f_{SMCLK} = 0$  MHz
- (6) Low-power mode 4, CPUOFF = 1, SCG0 = 1 SCG1 = 1, OSCOFF = 1 (LPM4), CPU and all clocks are disabled, WDT and RTC disabled
- (7) Low-power mode 4, VLO, excludes SVS test conditions:  
Current for RTC clocked by VLO included. Current for brownout included. SVS disabled (SVSHE = 0).  
CPUOFF = 1, SCG0 = 1 SCG1 = 1, OSCOFF = 1 (LPM4)  
 $f_{XT1} = 0$  Hz,  $f_{MCLK} = f_{SMCLK} = 0$  MHz
- (8) Low-power mode 4, XT1, excludes SVS test conditions:  
Current for RTC clocked by XT1 included. Current for brownout included. SVS disabled (SVSHE = 0).  
CPUOFF = 1, SCG0 = 1 SCG1 = 1, OSCOFF = 1 (LPM4)  
 $f_{XT1} = 32768$  Hz,  $f_{MCLK} = f_{SMCLK} = 0$  MHz
- (9) RTC periodically wakes up every second with external 32768-Hz input as source.

## 8.8 Low-Power Mode (LPMx.5) Supply Currents (Into $V_{CC}$ ) Excluding External Current

over recommended ranges of supply voltage and operating free-air temperature (unless otherwise noted)

PARAMETER		$V_{CC}$	- 40°C		25°C		85°C		UNIT
			TYP	MAX	TYP	MAX	TYP	MAX	
$I_{LPM3.5, XT1}$	Low-power mode 3.5, 12.5-pF crystal, includes SVS <sup>(1) (2) (3)</sup> (also see <a href="#">Fig 8-3</a> )	3 V	0.57		0.63		0.81	1.54	$\mu A$
		2 V	0.54		0.60		0.79		
$I_{LPM4.5, SVS}$	Low-power mode 4.5, includes SVS <sup>(4)</sup>	3 V	0.23		0.25		0.31	0.45	$\mu A$
		2 V	0.21		0.23		0.29		
$I_{LPM4.5}$	Low-power mode 4.5, excludes SVS <sup>(5)</sup>	3 V	0.027		0.036		0.080	0.15	$\mu A$
		2 V	0.022		0.031		0.073		

- (1) Not applicable for MCUs with HF crystal oscillator only.
- (2) Characterized with a Seiko Crystal SC-32S crystal with a load capacitance chosen to closely match the required load.
- (3) Low-power mode 3.5, 12.5-pF crystal, includes SVS test conditions:  
Current for RTC clocked by XT1 included. Current for brownout and SVS included (SVSHE = 1). Core regulator disabled.  
PMMREGOFF = 1, CPUOFF = 1, SCG0 = 1 SCG1 = 1, OSCOFF = 1 (LPMx.5),  
 $f_{XT1} = 32768$  Hz,  $f_{ACLK} = 0$ ,  $f_{MCLK} = f_{SMCLK} = 0$  MHz
- (4) Low-power mode 4.5, includes SVS test conditions:  
Current for brownout and SVS included (SVSHE = 1). Core regulator disabled.  
PMMREGOFF = 1, CPUOFF = 1, SCG0 = 1 SCG1 = 1, OSCOFF = 1 (LPMx.5)  
 $f_{XT1} = 0$  Hz,  $f_{ACLK} = f_{MCLK} = f_{SMCLK} = 0$  MHz
- (5) Low-power mode 4.5, excludes SVS test conditions:  
Current for brownout included. SVS disabled (SVSHE = 0). Core regulator disabled.  
PMMREGOFF = 1, CPUOFF = 1, SCG0 = 1 SCG1 = 1, OSCOFF = 1 (LPMx.5)  
 $f_{XT1} = 0$  Hz,  $f_{ACLK} = f_{MCLK} = f_{SMCLK} = 0$  MHz

## 8.9 Typical Characteristics - Low-Power Mode Supply Currents

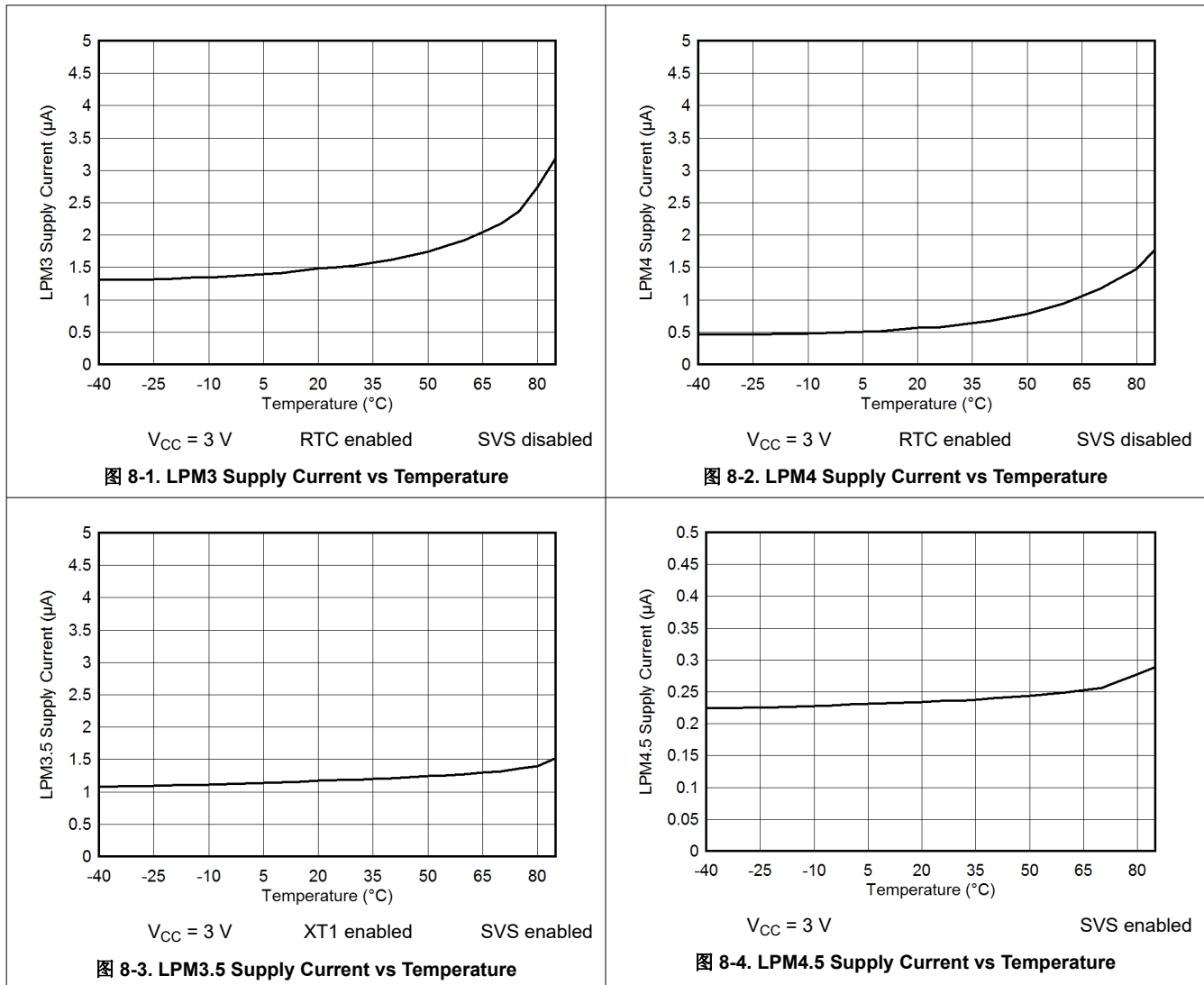

## 8.10 Typical Characteristics - Current Consumption Per Module

MODULE	TEST CONDITIONS	REFERENCE CLOCK	MIN	TYP	MAX	UNIT
Timer_A		Module input clock		5		$\mu\text{A}/\text{MHz}$
eUSCI_A	UART mode	Module input clock		7		$\mu\text{A}/\text{MHz}$
eUSCI_A	SPI mode	Module input clock		5		$\mu\text{A}/\text{MHz}$
eUSCI_B	SPI mode	Module input clock		5		$\mu\text{A}/\text{MHz}$
eUSCI_B	I <sup>2</sup> C mode, 100 kbaud	Module input clock		5		$\mu\text{A}/\text{MHz}$
RTC		32 kHz		85		nA
CRC	From start to end of operation	MCLK		8.5		$\mu\text{A}/\text{MHz}$

## 8.11 Thermal Resistance Characteristics

THERMAL METRIC <sup>(1)</sup>		VALUE <sup>(2)</sup>	UNIT
R <sup>θ</sup> <sub>JA</sub> Junction-to-ambient thermal resistance, still air	VQFN 20 pin (RHL)	37.8	°C/W
	TSSOP 16 pin (PW16)	101.7	
R <sup>θ</sup> <sub>JC</sub> Junction-to-case (top) thermal resistance	VQFN 20 pin (RHL)	34.1	°C/W
	TSSOP 16 pin (PW16)	33.7	
R <sup>θ</sup> <sub>JB</sub> Junction-to-board thermal resistance	VQFN 20 pin (RHL)	15.3	°C/W
	TSSOP 16 pin (PW16)	47.5	

(1) For more information about traditional and new thermal metrics, see [Semiconductor and IC Package Thermal Metrics](#).

(2) These values are based on a JEDEC-defined 2S2P system (with the exception of the Theta JC (R<sup>θ</sup><sub>JC</sub>) value, which is based on a JEDEC-defined 1S0P system) and will change based on environment and application. For more information, see these EIA/JEDEC standards:

- JESD51-2, *Integrated Circuits Thermal Test Method Environmental Conditions - Natural Convection (Still Air)*
- JESD51-3, *Low Effective Thermal Conductivity Test Board for Leaded Surface Mount Packages*
- JESD51-7, *High Effective Thermal Conductivity Test Board for Leaded Surface Mount Packages*
- JESD51-9, *Test Boards for Area Array Surface Mount Package Thermal Measurements*

## 8.12 Timing and Switching Characteristics

### 8.12.1 Power Supply Sequencing

节 8.12.1.1 lists the characteristics of the SVS and BOR.

#### 8.12.1.1 PMM, SVS and BOR

over recommended ranges of supply voltage and operating free-air temperature (unless otherwise noted)

PARAMETER		TEST CONDITIONS	MIN	TYP	MAX	UNIT
V <sub>BOR, safe</sub>	Safe BOR power-down level <sup>(1)</sup>		0.1			V
t <sub>BOR, safe</sub>	Safe BOR reset delay <sup>(2)</sup>		10			ms
I <sub>SVSH, AM</sub>	SVS <sub>H</sub> current consumption, active mode	V <sub>CC</sub> = 3.6 V			1.5	μA
I <sub>SVSH, LPM</sub>	SVS <sub>H</sub> current consumption, low-power modes	V <sub>CC</sub> = 3.6 V		240		nA
V <sub>SVSH-</sub>	SVS <sub>H</sub> power-down level <sup>(3)</sup>		1.71	1.80	1.87	V
V <sub>SVSH+</sub>	SVS <sub>H</sub> power-up level <sup>(3)</sup>		1.76	1.88	1.99	V
V <sub>SVSH_hys</sub>	SVS <sub>H</sub> hysteresis			80		mV
t <sub>PD, SVSH, AM</sub>	SVS <sub>H</sub> propagation delay, active mode				10	μs
t <sub>PD, SVSH, LPM</sub>	SVS <sub>H</sub> propagation delay, low-power modes				100	μs

(1) A safe BOR can be correctly generated only if DVCC drops below this voltage before it rises.

(2) When an BOR occurs, a safe BOR can be correctly generated only if DVCC is kept low longer than this period before it reaches V<sub>SVSH+</sub>.

(3) For additional information, see the [Dynamic Voltage Scaling Power Solution for MSP430 Devices With Single-Channel LDO Reference Design](#).



图 8-5. Power Cycle, SVS, and BOR Reset Conditions

## 8.12.2 Reset Timing

节 8.12.2.1 lists the timing characteristics of wakeup from LPMs and reset.

### 8.12.2.1 Wake-up Times From Low-Power Modes and Reset

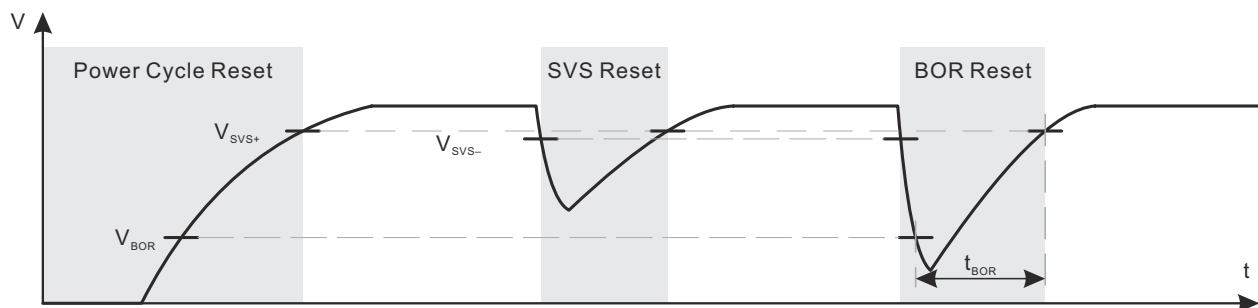
over recommended ranges of supply voltage and operating free-air temperature (unless otherwise noted)

PARAMETER		TEST CONDITIONS	V <sub>CC</sub>	MIN	TYP	MAX	UNIT
t <sub>WAKE-UP FRAM</sub>	Additional wake-up time to activate the FRAM in AM if previously disabled by the FRAM controller or from a LPM if immediate activation is selected for wakeup <sup>(1)</sup>		3 V		10		μs
t <sub>WAKE-UP LPM0</sub>	Wake-up time from LPM0 to active mode <sup>(1)</sup>		3 V			200 + 2.5 / f <sub>DCO</sub>	ns
t <sub>WAKE-UP LPM3</sub>	Wake-up time from LPM3 to active mode <sup>(2)</sup>		3 V		10		μs
t <sub>WAKE-UP LPM4</sub>	Wake-up time from LPM4 to active mode		3 V		10		μs
t <sub>WAKE-UP LPM3.5</sub>	Wake-up time from LPM3.5 to active mode <sup>(2)</sup>		3 V		350		μs
t <sub>WAKE-UP LPM4.5</sub>	Wake-up time from LPM4.5 to active mode <sup>(2)</sup>	SVSHE = 1	3 V		350		μs
		SVSHE = 0			1		ms
t <sub>WAKE-UP-RESET</sub>	Wake-up time from RST or BOR event to active mode <sup>(2)</sup>		3 V		1		ms
t <sub>RESET</sub>	Pulse duration required at RST/NMI pin to accept a reset		3 V		2		μs

- (1) The wake-up time is measured from the edge of an external wake-up signal (for example, port interrupt or wake-up event) to the first externally observable MCLK clock edge.
- (2) The wake-up time is measured from the edge of an external wake-up signal (for example, port interrupt or wake-up event) until the first instruction of the user program is executed.

## 8.12.3 Clock Specifications

节 8.12.3.1 lists the characteristics of the LF XT1.

### 8.12.3.1 XT1 Crystal Oscillator (Low Frequency)

over recommended ranges of supply voltage and operating free-air temperature (unless otherwise noted)<sup>(1) (2)</sup>

PARAMETER		TEST CONDITIONS	V <sub>CC</sub>	MIN	TYP	MAX	UNIT
f <sub>XT1, LF</sub>	XT1 oscillator crystal, low frequency	LFXTBYPASS = 0			32768		Hz
DC <sub>XT1, LF</sub>	XT1 oscillator LF duty cycle	Measured at MCLK, f <sub>LFXT</sub> = 32768 Hz		30%		70%	
f <sub>XT1, SW</sub>	XT1 oscillator logic-level square-wave input frequency	LFXTBYPASS = 1 <sup>(3) (4)</sup>			32.768		kHz
DC <sub>XT1, SW</sub>	LFXT oscillator logic-level square-wave input duty cycle	LFXTBYPASS = 1		40%		60%	
OA <sub>LFXT</sub>	Oscillation allowance for LF crystals <sup>(5)</sup>	LFXTBYPASS = 0, LFXTDRIVE = {3}, f <sub>LFXT</sub> = 32768 Hz, C <sub>L,eff</sub> = 12.5 pF			200		kΩ
C <sub>L,eff</sub>	Integrated effective load capacitance <sup>(6)</sup>	See <sup>(7)</sup>			1		pF
t <sub>START, LFXT</sub>	Start-up time <sup>(9)</sup>	f <sub>OSC</sub> = 32768 Hz, LFXTBYPASS = 0, LFXTDRIVE = {3}, T <sub>A</sub> = 25°C, C <sub>L,eff</sub> = 12.5 pF			1000		ms
f <sub>Fault, LFXT</sub>	Oscillator fault frequency <sup>(10)</sup>	XTS = 0 <sup>(8)</sup>		0		3500	Hz

- (1) To improve EMI on the LFXT oscillator, observe the following guidelines:
  - Keep the trace between the device and the crystal as short as possible.
  - Design a good ground plane around the oscillator pins.
  - Prevent crosstalk from other clock or data lines into oscillator pins XIN and XOUT.
  - Avoid running PCB traces underneath or adjacent to the XIN and XOUT pins.
  - Use assembly materials and processes that avoid any parasitic load on the oscillator XIN and XOUT pins.
  - If conformal coating is used, make sure that it does not induce capacitive or resistive leakage between the oscillator pins.
- (2) See [MSP430 32-kHz Crystal Oscillators](#) for details on crystal section, layout, and testing.
- (3) When LFXTBYPASS is set, LFXT circuits are automatically powered down. Input signal is a digital square wave with parametrics defined in the Schmitt-trigger inputs section of this data sheet. Duty cycle requirements are defined by DC<sub>LFXT, SW</sub>.
- (4) Maximum frequency of operation of the entire device cannot be exceeded.
- (5) Oscillation allowance is based on a safety factor of 5 for recommended crystals. The oscillation allowance is a function of the LFXTDRIVE settings and the effective load. In general, comparable oscillator allowance can be achieved based on the following guidelines, but should be evaluated based on the actual crystal selected for the application:
  - For LFXTDRIVE = {0}, C<sub>L,eff</sub> = 3.7 pF
  - For LFXTDRIVE = {1}, 6 pF ≤ C<sub>L,eff</sub> ≤ 9 pF
  - For LFXTDRIVE = {2}, 6 pF ≤ C<sub>L,eff</sub> ≤ 10 pF
  - For LFXTDRIVE = {3}, 6 pF ≤ C<sub>L,eff</sub> ≤ 12 pF
- (6) Includes parasitic bond and package capacitance (approximately 2 pF per pin).
- (7) Requires external capacitors at both terminals to meet the effective load capacitance specified by crystal manufacturers. Recommended effective load capacitance values supported are 3.7 pF, 6 pF, 9 pF, and 12.5 pF. Maximum shunt capacitance of 1.6 pF. The PCB adds additional capacitance, so it must also be considered in the overall capacitance. Verify that the recommended effective load capacitance of the selected crystal is met.
- (8) Measured with logic-level input frequency but also applies to operation with crystals.
- (9) Includes start-up counter of 1024 clock cycles.
- (10) Frequencies above the MAX specification do not set the fault flag. Frequencies between the MIN and MAX specifications might set the flag. A static condition or stuck at fault condition sets the flag.

### 8.12.3.2 DCO FLL, Frequency

over recommended operating free-air temperature (unless otherwise noted)

PARAMETER		TEST CONDITIONS	V <sub>CC</sub>	MIN	TYP	MAX	UNIT
f <sub>DCO, FLL</sub>	FLL lock frequency, 16 MHz, 25°C	Measured at MCLK, Internal trimmed REFO as reference	3 V	- 1.0%		1.0%	
	FLL lock frequency, 16 MHz, - 40°C to 85°C		3 V	- 2.0%		2.0%	
	FLL lock frequency, 16 MHz, - 40°C to 85°C	Measured at MCLK, XT1 crystal as reference	3 V	- 0.5%		0.5%	
f <sub>DUTY</sub>	Duty cycle	Measured at MCLK, XT1 crystal as reference	3 V	40%	50%	60%	
Jitter <sub>cc</sub>	Cycle-to-cycle jitter, 16 MHz		3 V		0.25%		
Jitter <sub>long</sub>	Long term jitter, 16 MHz		3 V		0.022%		
t <sub>FLL, lock</sub>	FLL lock time, 16MHz		3 V		280		ms

节 8.12.3.3 lists the characteristics of the DCO.

### 8.12.3.3 DCO Frequency

over recommended operating free-air temperature (unless otherwise noted) (see 图 8-6)

PARAMETER		TEST CONDITIONS	V <sub>CC</sub>	TYP	UNIT
f <sub>DCO, 16MHz</sub>	DCO frequency, 16 MHz	DCORSEL = 101b, DISMOD = 1b, DCOFTRIMEN = 1b, DCOFTRIM = 000b, DCO = 0	3 V	7.1	MHz
		DCORSEL = 101b, DISMOD = 1b, DCOFTRIMEN = 1b, DCOFTRIM = 000b, DCO = 511		11.8	
		DCORSEL = 101b, DISMOD = 1b, DCOFTRIMEN = 1b, DCOFTRIM = 111b, DCO = 0		17	
		DCORSEL = 101b, DISMOD = 1b, DCOFTRIMEN = 1b, DCOFTRIM = 111b, DCO = 511		27.7	
f <sub>DCO, 12MHz</sub>	DCO frequency, 12 MHz	DCORSEL = 100b, DISMOD = 1b, DCOFTRIMEN = 1b, DCOFTRIM = 000b, DCO = 0	3 V	5.5	MHz
		DCORSEL = 100b, DISMOD = 1b, DCOFTRIMEN = 1b, DCOFTRIM = 000b, DCO = 511		9.1	
		DCORSEL = 100b, DISMOD = 1b, DCOFTRIMEN = 1b, DCOFTRIM = 111b, DCO = 0		13.1	
		DCORSEL = 100b, DISMOD = 1b, DCOFTRIMEN = 1b, DCOFTRIM = 111b, DCO = 511		21.5	
f <sub>DCO, 8MHz</sub>	DCO frequency, 8 MHz	DCORSEL = 011b, DISMOD = 1b, DCOFTRIMEN = 1b, DCOFTRIM = 000b, DCO = 0	3 V	3.7	MHz
		DCORSEL = 011b, DISMOD = 1b, DCOFTRIMEN = 1b, DCOFTRIM = 000b, DCO = 511		6.3	
		DCORSEL = 011b, DISMOD = 1b, DCOFTRIMEN = 1b, DCOFTRIM = 111b, DCO = 0		9.0	
		DCORSEL = 011b, DISMOD = 1b, DCOFTRIMEN = 1b, DCOFTRIM = 111b, DCO = 511		14.9	
f <sub>DCO, 4MHz</sub>	DCO frequency, 4 MHz	DCORSEL = 010b, DISMOD = 1b, DCOFTRIMEN = 1b, DCOFTRIM = 000b, DCO = 0	3 V	1.9	MHz
		DCORSEL = 010b, DISMOD = 1b, DCOFTRIMEN = 1b, DCOFTRIM = 000b, DCO = 511		3.2	
		DCORSEL = 010b, DISMOD = 1b, DCOFTRIMEN = 1b, DCOFTRIM = 111b, DCO = 0		4.6	
		DCORSEL = 010b, DISMOD = 1b, DCOFTRIMEN = 1b, DCOFTRIM = 111b, DCO = 511		7.8	

over recommended operating free-air temperature (unless otherwise noted) (see 图 8-6)

PARAMETER	TEST CONDITIONS	V <sub>CC</sub>	TYP	UNIT
f <sub>DCO, 2MHz</sub> DCO frequency, 2 MHz	DCORSEL = 001b, DISMOD = 1b, DCOFRIMEN = 1b, DCOFRIM = 000b, DCO = 0	3 V	0.96	MHz
	DCORSEL = 001b, DISMOD = 1b, DCOFRIMEN = 1b, DCOFRIM = 000b, DCO = 511		1.6	
	DCORSEL = 001b, DISMOD = 1b, DCOFRIMEN = 1b, DCOFRIM = 111b, DCO = 0		2.3	
	DCORSEL = 001b, DISMOD = 1b, DCOFRIMEN = 1b, DCOFRIM = 111b, DCO = 511		4.0	
f <sub>DCO, 1MHz</sub> DCO frequency, 1 MHz	DCORSEL = 000b, DISMOD = 1b, DCOFRIMEN = 1b, DCOFRIM = 000b, DCO = 0	3 V	0.5	MHz
	DCORSEL = 000b, DISMOD = 1b, DCOFRIMEN = 1b, DCOFRIM = 000b, DCO = 511		0.85	
	DCORSEL = 000b, DISMOD = 1b, DCOFRIMEN = 1b, DCOFRIM = 111b, DCO = 0		1.2	
	DCORSEL = 000b, DISMOD = 1b, DCOFRIMEN = 1b, DCOFRIM = 111b, DCO = 511		2.0	



图 8-6. Typical DCO Frequency

节 8.12.3.4 lists the characteristics of the REFO.

### 8.12.3.4 REFO

over recommended operating free-air temperature (unless otherwise noted)

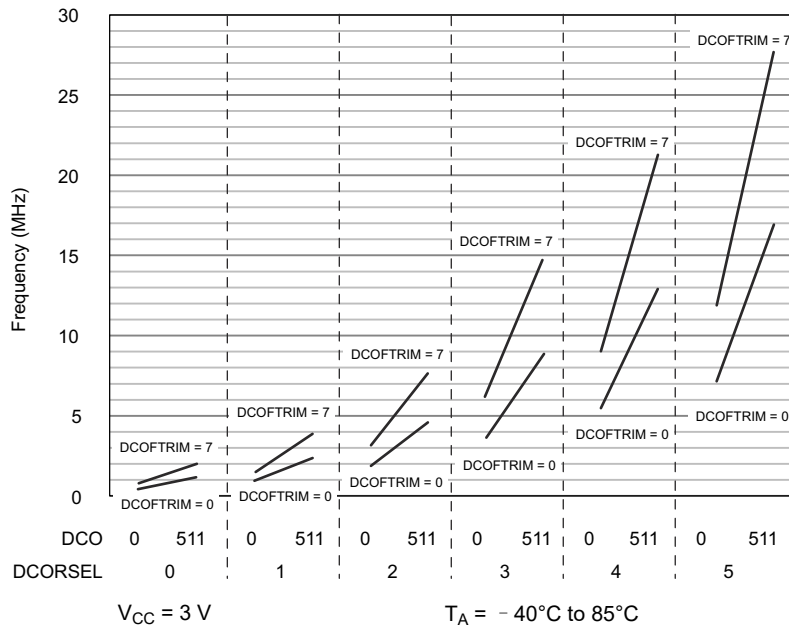
PARAMETER		TEST CONDITIONS	V <sub>CC</sub>	MIN	TYP	MAX	UNIT
I <sub>REFO</sub>	REFO oscillator current consumption	T <sub>A</sub> = 25°C	3 V		15		μA
f <sub>REFO</sub>	REFO calibrated frequency	Measured at MCLK	3 V		32768		Hz
	REFO absolute calibrated tolerance	- 40°C to 85°C	1.8 V to 3.6 V	- 3.5%		+3.5%	
df <sub>REFO</sub> /dT	REFO frequency temperature drift	Measured at MCLK <sup>(1)</sup>	3 V		0.01		%/°C
df <sub>REFO</sub> /dV <sub>CC</sub>	REFO frequency supply voltage drift	Measured at MCLK at 25°C <sup>(2)</sup>	1.8 V to 3.6 V		1		%/V
f <sub>DC</sub>	REFO duty cycle	Measured at MCLK	1.8 V to 3.6 V	40%	50%	60%	
t <sub>START</sub>	REFO start-up time	40% to 60% duty cycle			50		μs

(1) Calculated using the box method: (MAX(- 40°C to 85°C) - MIN(- 40°C to 85°C)) / MIN(- 40°C to 85°C) / (85°C - (- 40°C))

(2) Calculated using the box method: (MAX(1.8 V to 3.6 V) - MIN(1.8 V to 3.6 V)) / MIN(1.8 V to 3.6 V) / (3.6 V - 1.8 V)

节 8.12.3.5 lists the characteristics of the VLO.

### 8.12.3.5 Internal Very-Low-Power Low-Frequency Oscillator (VLO)

over recommended ranges of supply voltage and operating free-air temperature (unless otherwise noted)

PARAMETER		TEST CONDITIONS	V <sub>CC</sub>	TYP	UNIT
f <sub>VLO</sub>	VLO frequency	Measured at MCLK	3 V	10	kHz
df <sub>VLO</sub> /dT	VLO frequency temperature drift	Measured at MCLK <sup>(1)</sup>	3 V	0.5	%/°C
df <sub>VLO</sub> /dV <sub>CC</sub>	VLO frequency supply voltage drift	Measured at MCLK <sup>(2)</sup>	1.8 V to 3.6 V	4	%/V
f <sub>VLO,DC</sub>	Duty cycle	Measured at MCLK	3 V	50%	

(1) Calculated using the box method: (MAX(- 40°C to 85°C) - MIN(- 40°C to 85°C)) / MIN(- 40°C to 85°C) / (85°C - (- 40°C))

(2) Calculated using the box method: (MAX(1.8 V to 3.6 V) - MIN(1.8 V to 3.6 V)) / MIN(1.8 V to 3.6 V) / (3.6 V - 1.8 V)

#### Note

The VLO clock frequency is reduced by 15% (typical) when the device switches from active mode to LPM3 or LPM4, because the reference changes. This lower frequency is not a violation of the VLO specifications (see 节 8.12.3.5).

节 8.12.3.6 lists the characteristics of the MODOSC.

### 8.12.3.6 Module Oscillator (MODOSC)

over recommended ranges of supply voltage and operating free-air temperature (unless otherwise noted)

PARAMETER		TEST CONDITIONS	V <sub>CC</sub>	MIN	TYP	MAX	UNIT
f <sub>MODOSC</sub>	MODOSC frequency		3 V	3.8	4.8	5.8	MHz
f <sub>MODOSC</sub> /dT	MODOSC frequency temperature drift		3 V		0.102		%/°C
f <sub>MODOSC</sub> /dV <sub>CC</sub>	MODOSC frequency supply voltage drift		1.8 V to 3.6 V		1.02		%/V
f <sub>MODOSC,DC</sub>	Duty cycle		3 V	40%	50%	60%	

## 8.12.4 Digital I/Os

节 8.12.4.1 lists the characteristics of the digital inputs.

### 8.12.4.1 Digital Inputs

over recommended ranges of supply voltage and operating free-air temperature (unless otherwise noted)

PARAMETER		TEST CONDITIONS	V <sub>CC</sub>	MIN	TYP	MAX	UNIT
V <sub>IT+</sub>	Positive-going input threshold voltage		2 V	0.90		1.50	V
			3 V	1.35		2.25	
V <sub>IT-</sub>	Negative-going input threshold voltage		2 V	0.50		1.10	V
			3 V	0.75		1.65	
V <sub>hys</sub>	Input voltage hysteresis (V <sub>IT+</sub> - V <sub>IT-</sub> )		2 V	0.3		0.8	V
			3 V	0.4		1.2	
R <sub>Pull</sub>	Pullup or pulldown resistor	For pullup: V <sub>IN</sub> = V <sub>SS</sub> For pulldown: V <sub>IN</sub> = V <sub>CC</sub>		20	35	50	k Ω
C <sub>I,dig</sub>	Input capacitance, digital only port pins	V <sub>IN</sub> = V <sub>SS</sub> or V <sub>CC</sub>			3		pF
C <sub>I,ana</sub>	Input capacitance, port pins with shared analog functions	V <sub>IN</sub> = V <sub>SS</sub> or V <sub>CC</sub>			5		pF
I <sub>kg(Px.y)</sub>	High-impedance leakage current of GPIO pins	See (1) (2)	2 V, 3 V	- 20		20	nA
t <sub>(int)</sub>	External interrupt timing (external trigger pulse duration to set interrupt flag) <sup>(3)</sup>	Ports with interrupt capability (see block diagram and terminal function descriptions)	2 V, 3 V	50			ns

- (1) The leakage current is measured with V<sub>SS</sub> or V<sub>CC</sub> applied to the corresponding pins, unless otherwise noted.
- (2) The leakage of the digital port pins is measured individually. The port pin is selected for input and the pullup or pulldown resistor is disabled.
- (3) An external signal sets the interrupt flag every time the minimum interrupt pulse duration t<sub>(int)</sub> is met. It may be set by trigger signals shorter than t<sub>(int)</sub>.

节 8.12.4.2 lists the characteristics of the digital outputs.

### 8.12.4.2 Digital Outputs

over recommended ranges of supply voltage and operating free-air temperature (unless otherwise noted)

PARAMETER		TEST CONDITIONS	V <sub>CC</sub>	MIN	TYP	MAX	UNIT
V <sub>OH</sub>	High-level output voltage	I <sub>(OHmax)</sub> = - 3 mA <sup>(1)</sup>	2 V	1.4		2.0	V
		I <sub>(OHmax)</sub> = - 5 mA <sup>(1)</sup>	3 V	2.4		3.0	
V <sub>OL</sub>	Low-level output voltage	I <sub>(OLmax)</sub> = 3 mA <sup>(1)</sup>	2 V	0.0		0.60	V
		I <sub>(OHmax)</sub> = 5 mA <sup>(1)</sup>	3 V	0.0		0.60	
f <sub>Port_CLK</sub>	Clock output frequency	C <sub>L</sub> = 20 pF <sup>(2)</sup>	2 V	16			MHz
			3 V	16			
t <sub>rise,dig</sub>	Port output rise time, digital only port pins	C <sub>L</sub> = 20 pF	2 V		10		ns
			3 V		7		
t <sub>fall,dig</sub>	Port output fall time, digital only port pins	C <sub>L</sub> = 20 pF	2 V		10		ns
			3 V		5		

- (1) The maximum total current, I<sub>(OHmax)</sub> and I<sub>(OLmax)</sub>, for all outputs combined should not exceed ±48 mA to hold the maximum voltage drop specified.
- (2) The port can output frequencies at least up to the specified limit and might support higher frequencies.

**8.12.4.3 Typical Characteristics - Outputs at 3 V and 2 V**

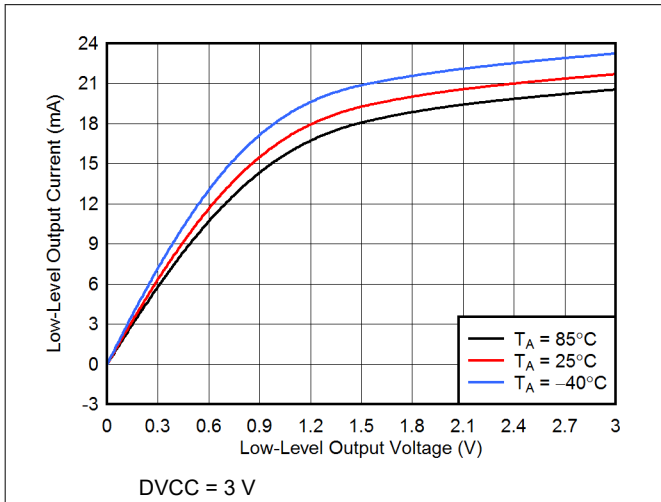

**图 8-7. Typical Low-Level Output Current vs Low-Level Output Voltage**

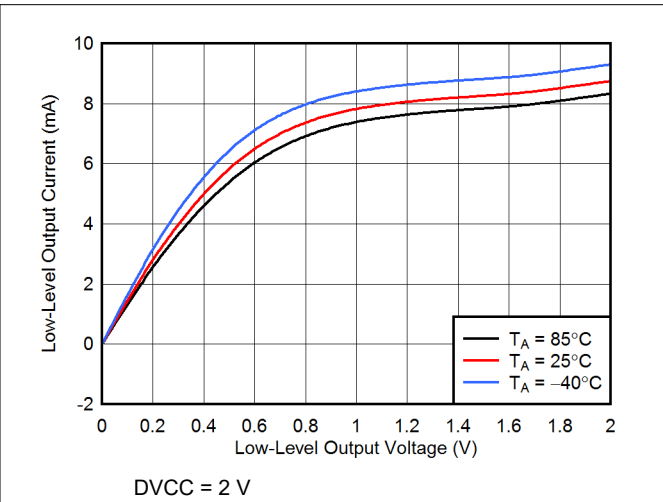

**图 8-8. Typical Low-Level Output Current vs Low-Level Output Voltage**

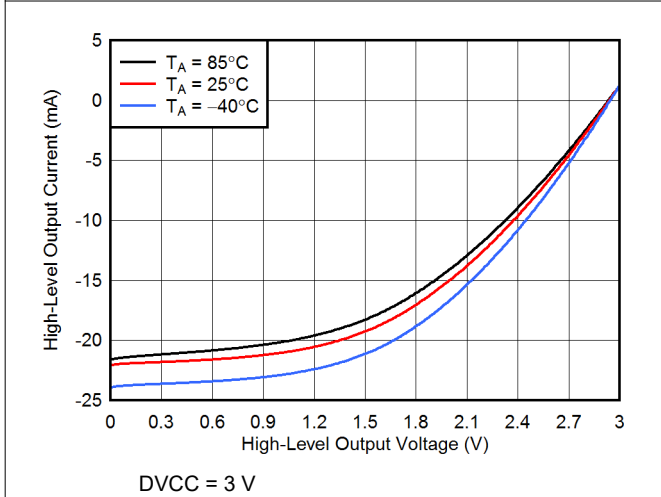

**图 8-9. Typical High-Level Output Current vs High-Level Output Voltage**

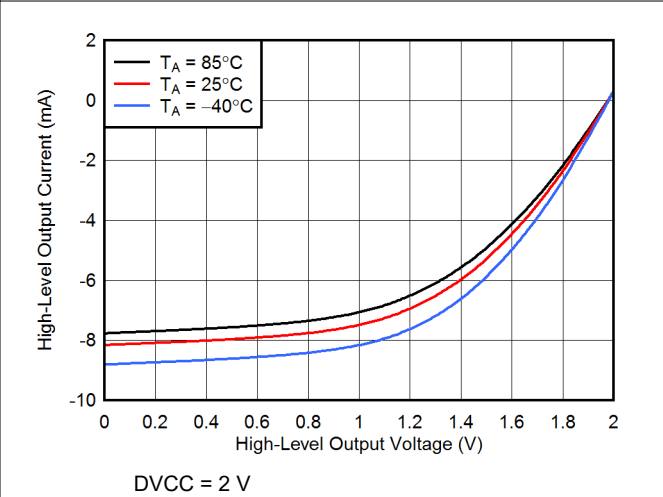

**图 8-10. Typical High-Level Output Current vs High-Level Output Voltage**

### 8.12.5 VREF+ Built-in Reference

节 8.12.5.1 lists the characteristics of the VREF+.

#### 8.12.5.1 VREF+

over recommended ranges of supply voltage and operating free-air temperature (unless otherwise noted)

PARAMETER	TEST CONDITIONS	V <sub>CC</sub>	MIN	TYP	MAX	UNIT	
V <sub>REF+</sub>	Positive built-in reference voltage	EXTREFEN = 1 with 1-mA load current	2 V, 3 V	1.15	1.19	1.23	V
TC <sub>REF+</sub>	Temperature coefficient of built-in reference voltage			30		μV/°C	

### 8.12.6 Timer\_A

节 8.12.6.1 lists the characteristics of Timer\_A.

#### 8.12.6.1 Timer\_A

over recommended ranges of supply voltage and operating free-air temperature (unless otherwise noted)

PARAMETER	TEST CONDITIONS	V <sub>CC</sub>	MIN	TYP	MAX	UNIT
f <sub>TA</sub>	Timer_A input clock frequency	Internal: SMCLK, ACLK External: TACLK Duty cycle = 50% ±10%	2 V, 3 V		16	MHz
t <sub>TA,cap</sub>	Timer_A capture timing	All capture inputs, minimum pulse duration required for capture	2 V, 3 V	20		ns



图 8-11. Timer PWM Mode



图 8-12. Timer Capture Mode

### 8.12.7 eUSCI

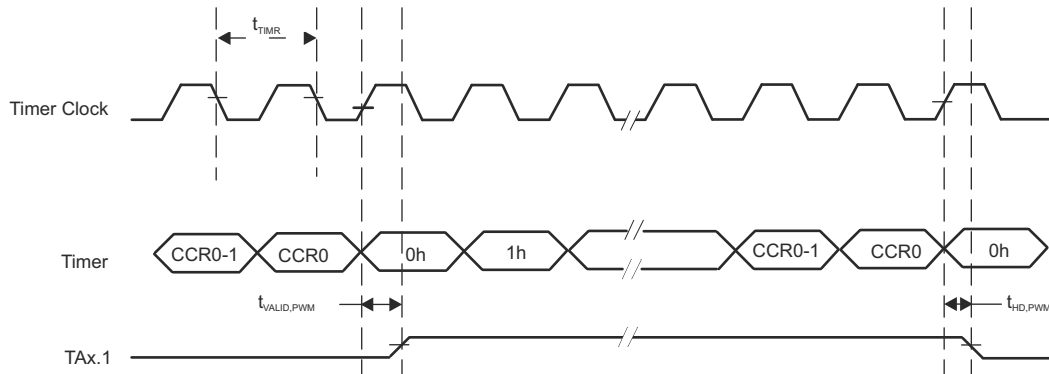
节 8.12.7.1 lists the supported frequencies of the eUSCI in UART mode.

#### 8.12.7.1 eUSCI (UART Mode) Clock Frequency

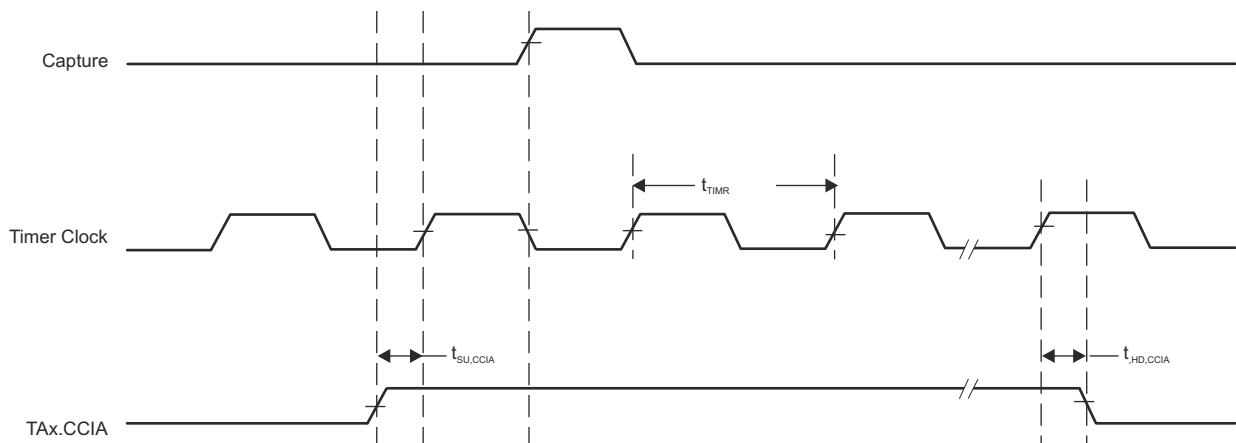
over recommended ranges of supply voltage and operating free-air temperature (unless otherwise noted)

PARAMETER		TEST CONDITIONS	V <sub>CC</sub>	MIN	MAX	UNIT
f <sub>eUSCI</sub>	eUSCI input clock frequency	Internal: SMCLK, MODCLK External: UCLK Duty cycle = 50% ±10%	2 V, 3 V		16	MHz
f <sub>BITCLK</sub>	BITCLK clock frequency (equals baud rate in Mbaud)		2 V, 3 V		5	MHz

节 8.12.7.2 lists the characteristics of the eUSCI in UART mode.

#### 8.12.7.2 eUSCI (UART Mode)

over recommended ranges of supply voltage and operating free-air temperature (unless otherwise noted)

PARAMETER		TEST CONDITIONS	V <sub>CC</sub>	TYP	UNIT
t <sub>t</sub>	UART receive deglitch time <sup>(1)</sup>	UCGLITx = 0	2 V, 3 V	12	ns
		UCGLITx = 1		40	
		UCGLITx = 2		68	
		UCGLITx = 3		110	

(1) Pulses on the UART receive input (UCxRX) shorter than the UART receive deglitch time are suppressed. To ensure that pulses are correctly recognized, their duration should exceed the maximum specification of the deglitch time.

节 8.12.7.3 lists the supported frequencies of the eUSCI in SPI master mode.

#### 8.12.7.3 eUSCI (SPI Master Mode) Clock Frequency

over recommended ranges of supply voltage and operating free-air temperature (unless otherwise noted)

PARAMETER		TEST CONDITIONS	MIN	MAX	UNIT
f <sub>eUSCI</sub>	eUSCI input clock frequency	Internal: SMCLK, MODCLK Duty cycle = 50% ±10%		8	MHz

节 8.12.7.4 lists the characteristics of the eUSCI in SPI master mode.

### 8.12.7.4 eUSCI (SPI Master Mode)

over recommended ranges of supply voltage and operating free-air temperature (unless otherwise noted)<sup>(1)</sup>

PARAMETER		TEST CONDITIONS	V <sub>CC</sub>	MIN	MAX	UNIT
t <sub>STE,LEAD</sub>	STE lead time, STE active to clock	UCSTEM = 0, UCMODEx = 01 or 10		1		UCxCLK cycles
		UCSTEM = 1, UCMODEx = 01 or 10				
t <sub>STE,LAG</sub>	STE lag time, last clock to STE inactive	UCSTEM = 0, UCMODEx = 01 or 10		1		UCxCLK cycles
		UCSTEM = 1, UCMODEx = 01 or 10				
t <sub>SU,MI</sub>	SOMI input data setup time		2 V	48		ns
			3 V	37		
t <sub>HD,MI</sub>	SOMI input data hold time		2 V	0		ns
			3 V	0		
t <sub>VALID,MO</sub>	SIMO output data valid time <sup>(2)</sup>	UCLK edge to SIMO valid, C <sub>L</sub> = 20 pF	2 V		20	ns
			3 V		20	
t <sub>HD,MO</sub>	SIMO output data hold time <sup>(3)</sup>	C <sub>L</sub> = 20 pF	2 V	-6		ns
			3 V	-5		

- (1)  $f_{UCxCLK} = 1/2t_{LO/HI}$  with  $t_{LO/HI} = \max(t_{VALID,MO}(eUSCI) + t_{SU,SI}(Slave), t_{SU,MI}(eUSCI) + t_{VALID,SO}(Slave))$   
For the slave parameters  $t_{SU,SI}(Slave)$  and  $t_{VALID,SO}(Slave)$ , see the SPI parameters of the attached slave.
- (2) Specifies the time to drive the next valid data to the SIMO output after the output changing UCLK clock edge. See the timing diagrams in 图 8-13 and 图 8-14.
- (3) Specifies how long data on the SIMO output is valid after the output changing UCLK clock edge. Negative values indicate that the data on the SIMO output can become invalid before the output changing clock edge observed on UCLK. See the timing diagrams in 图 8-13 and 图 8-14.



图 8-13. SPI Master Mode, CKPH = 0



图 8-14. SPI Master Mode, CKPH = 1

节 8.12.7.5 lists the characteristics of the eUSCI in SPI slave mode.

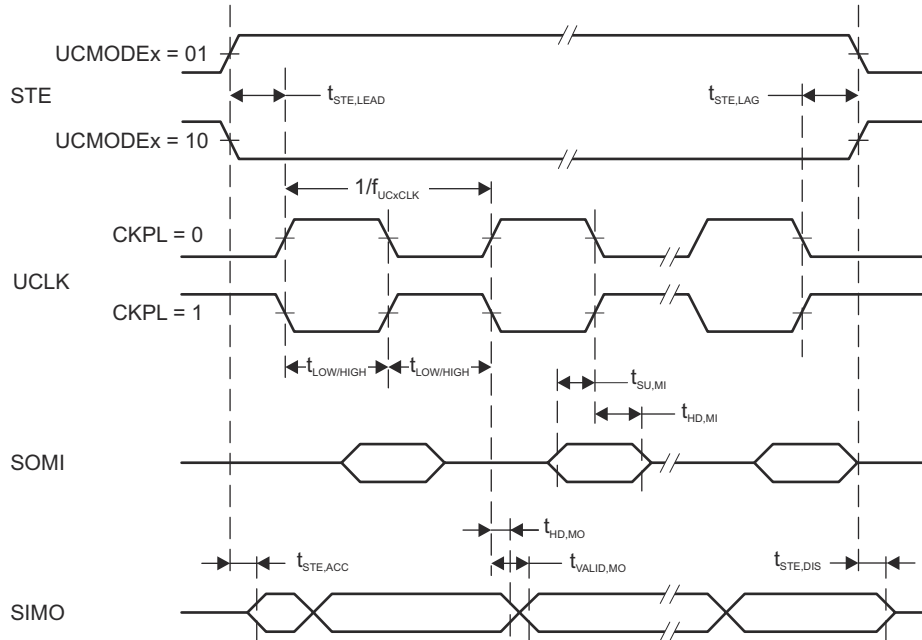
### 8.12.7.5 eUSCI (SPI Slave Mode)

over recommended ranges of supply voltage and operating free-air temperature (unless otherwise noted)<sup>(1)</sup>

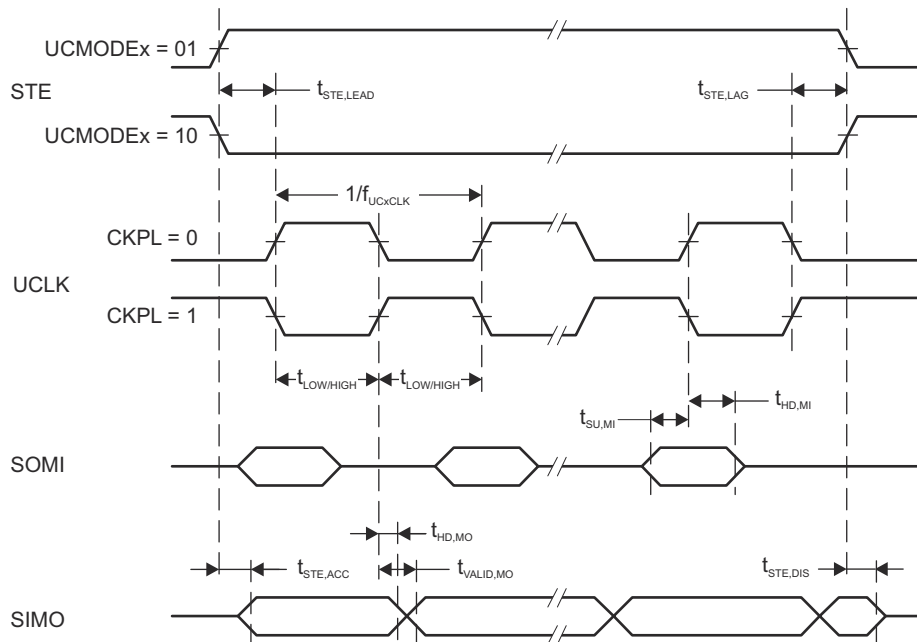
PARAMETER		TEST CONDITIONS	V <sub>CC</sub>	MIN	MAX	UNIT
t <sub>STE,LEAD</sub>	STE lead time, STE active to clock		2 V	55		ns
			3 V	45		
t <sub>STE,LAG</sub>	STE lag time, Last clock to STE inactive		2 V	20		ns
			3 V	20		
t <sub>STE,ACC</sub>	STE access time, STE active to SOMI data out		2 V		65	ns
			3 V		40	
t <sub>STE,DIS</sub>	STE disable time, STE inactive to SOMI high impedance		2 V		40	ns
			3 V		35	
t <sub>SU,SI</sub>	SIMO input data setup time		2 V	8		ns
			3 V	6		
t <sub>HD,SI</sub>	SIMO input data hold time		2 V	12		ns
			3 V	12		
t <sub>VALID,SO</sub>	SOMI output data valid time <sup>(2)</sup>	UCLK edge to SOMI valid, C <sub>L</sub> = 20 pF	2 V		68	ns
			3 V		42	
t <sub>HD,SO</sub>	SOMI output data hold time <sup>(3)</sup>	C <sub>L</sub> = 20 pF	2 V	5		ns
			3 V	5		

- (1)  $f_{UCxCLK} = 1/2t_{LO/HI}$  with  $t_{LO/HI} \geq \max(t_{VALID,MO(Master)} + t_{SU,SI(eUSCI)}, t_{SU,MI(Master)} + t_{VALID,SO(eUSCI)})$   
For the master parameters  $t_{SU,MI(Master)}$  and  $t_{VALID,MO(Master)}$ , see the SPI parameters of the attached master.
- (2) Specifies the time to drive the next valid data to the SOMI output after the output changing UCLK clock edge. See the timing diagrams in 图 8-15 and 图 8-16.
- (3) Specifies how long data on the SOMI output is valid after the output changing UCLK clock edge. See the timing diagrams in 图 8-15 and 图 8-16.



图 8-15. SPI Slave Mode, CKPH = 0



图 8-16. SPI Slave Mode, CKPH = 1

节 8.12.7.6 lists the characteristics of the eUSCI in I<sup>2</sup>C mode.

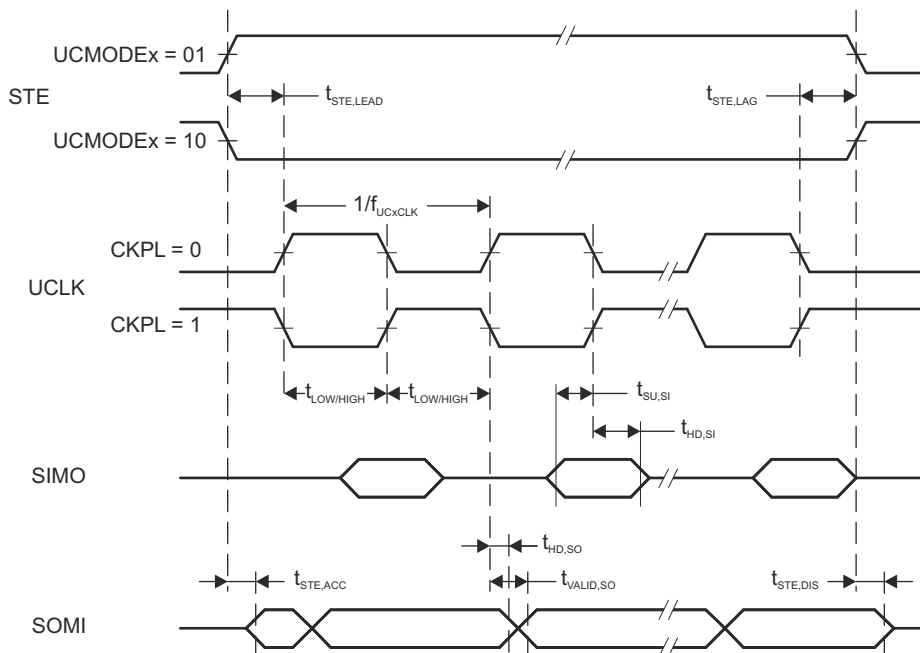
### 8.12.7.6 eUSCI (I<sup>2</sup>C Mode)

over recommended ranges of supply voltage and operating free-air temperature (unless otherwise noted) (see 图 8-17)

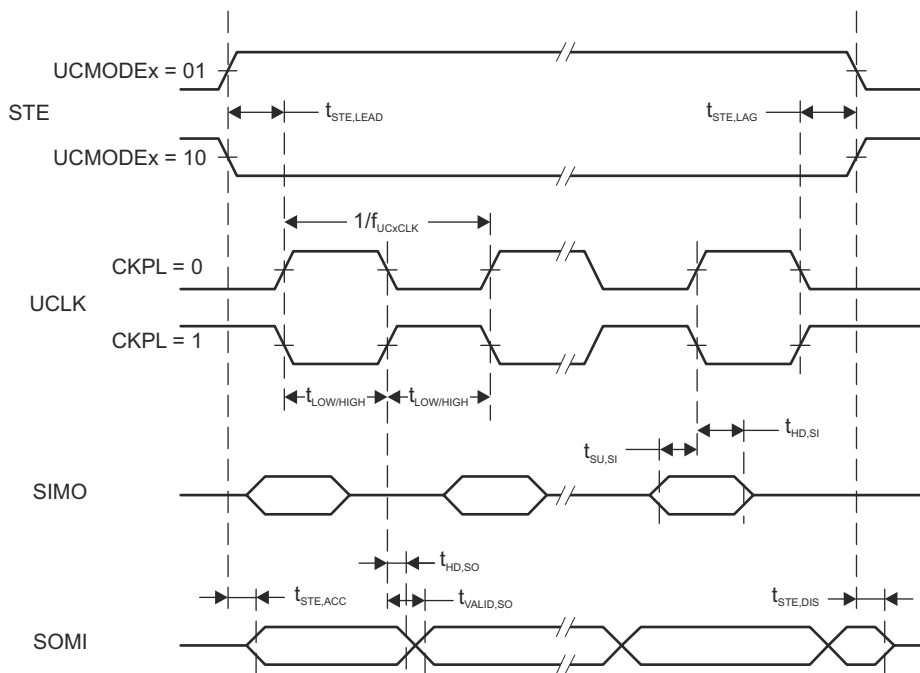
PARAMETER		TEST CONDITIONS	V <sub>CC</sub>	MIN	TYP	MAX	UNIT
f <sub>eUSCI</sub>	eUSCI input clock frequency	Internal: SMCLK, MODCLK External: UCLK Duty cycle = 50% ±10%				16	MHz
f <sub>SCL</sub>	SCL clock frequency		2 V, 3 V	0		400	kHz
t <sub>HD,STA</sub>	Hold time (repeated) START	f <sub>SCL</sub> = 100 kHz f <sub>SCL</sub> > 100 kHz	2 V, 3 V	4.0 0.6			μs
t <sub>SU,STA</sub>	Setup time for a repeated START	f <sub>SCL</sub> = 100 kHz f <sub>SCL</sub> > 100 kHz	2 V, 3 V	4.7 0.6			μs
t <sub>HD,DAT</sub>	Data hold time		2 V, 3 V	0			ns
t <sub>SU,DAT</sub>	Data setup time		2 V, 3 V	250			ns
t <sub>SU,STO</sub>	Setup time for STOP	f <sub>SCL</sub> = 100 kHz f <sub>SCL</sub> > 100 kHz	2 V, 3 V	4.0 0.6			μs
t <sub>SP</sub>	Pulse duration of spikes suppressed by input filter	UCGLITx = 0	2 V, 3 V	50		600	ns
		UCGLITx = 1		25	300		
		UCGLITx = 2		12.5	150		
		UCGLITx = 3		6.3	75		
t <sub>TIMEOUT</sub>	Clock low time-out	UCCLTOx = 1	2 V, 3 V		27		ms
		UCCLTOx = 2			30		
		UCCLTOx = 3			33		



图 8-17. I<sup>2</sup>C Mode Timing

## 8.12.8 ADC

节 8.12.8.1 lists the characteristics of the ADC power supply and input range conditions.

### 8.12.8.1 ADC, Power Supply and Input Range Conditions

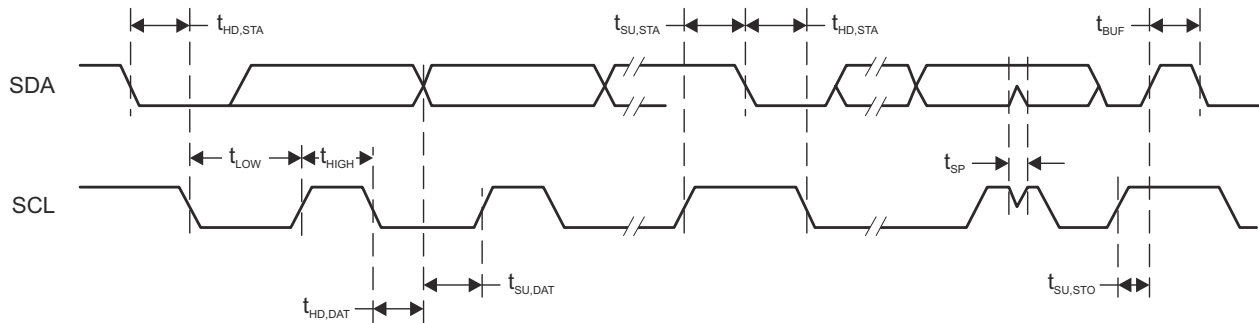
over operating free-air temperature range (unless otherwise noted)

PARAMETER		TEST CONDITIONS	V <sub>CC</sub>	MIN	TYP	MAX	UNIT
DV <sub>CC</sub>	ADC supply voltage			2.0		3.6	V
V <sub>(Ax)</sub>	Analog input voltage range	All ADC pins		0		DV <sub>CC</sub>	V
I <sub>ADC</sub>	Operating supply current into DV <sub>CC</sub> terminal, reference current not included, repeat-single-channel mode	f <sub>ADCCLK</sub> = 5 MHz, ADCON = 1, REFON = 0, SHT0 = 0, SHT1 = 0, ADCDIV = 0, ADCCONSEQx = 10b	2 V		185		μA
			3 V		207		
C <sub>I</sub>	Input capacitance	Only one terminal Ax can be selected at one time from the pad to the ADC capacitor array, including wiring and pad	2.2 V		2.5	3.5	pF
R <sub>I</sub>	Input MUX ON resistance	DV <sub>CC</sub> = 2 V, 0 V ≤ V <sub>Ax</sub> ≤ DV <sub>CC</sub>				36	k Ω

节 8.12.8.2 lists the ADC 10-bit timing parameters.

### 8.12.8.2 ADC, 10-Bit Timing Parameters

over operating free-air temperature range (unless otherwise noted)

PARAMETER		TEST CONDITIONS	V <sub>CC</sub>	MIN	TYP	MAX	UNIT
f <sub>ADCCLK</sub>		For specified performance of ADC linearity parameters	2 V to 3.6 V	0.45	5	5.5	MHz
f <sub>ADCOSC</sub>	Internal ADC oscillator (MODOSC)	ADCDIV = 0, f <sub>ADCCLK</sub> = f <sub>ADCOSC</sub>	2 V to 3.6 V	3.8	4.8	5.8	MHz
t <sub>CONVERT</sub>	Conversion time	REFON = 0, Internal oscillator, 10 ADCCLK cycles, 10-bit mode, f <sub>ADCOSC</sub> = 4.5 MHz to 5.5 MHz	2 V to 3.6 V	2.18		2.67	μs
		External f <sub>ADCCLK</sub> from ACLK, MCLK, or SMCLK, ADCSSEL ≠ 0	2 V to 3.6 V		12 × 1 / f <sub>ADCCLK</sub>		
t <sub>ADCON</sub>	Turnon settling time of the ADC	The error in a conversion started after t <sub>ADCON</sub> is less than ±0.5 LSB. Reference and input signal are already settled.				100	ns
t <sub>Sample</sub>	Sampling time	R <sub>S</sub> = 1000 Ω, R <sub>I</sub> = 36000 Ω, C <sub>I</sub> = 3.5 pF. Approximately 8 Tau (t) are required for an error of less than ±0.5 LSB. <sup>(1)</sup>	3 V	2.0			μs

(1)  $t_{\text{Sample}} = \ln(2^{n+1}) \times \tau$ , where n = ADC resolution,  $\tau = (R_I + R_S) \times C_I$

节 8.12.8.3 lists the ADC 10-bit linearity parameters.

### 8.12.8.3 ADC, 10-Bit Linearity Parameters

over operating free-air temperature range (unless otherwise noted)

PARAMETER		TEST CONDITIONS	V <sub>CC</sub>	MIN	TYP	MAX	UNIT
E <sub>I</sub>	Integral linearity error (10-bit mode)	V <sub>ref+</sub> reference	2.4 V to 3.6 V	-2		2	LSB
	Integral linearity error (8-bit mode)		2.0 V to 3.6 V	-2		2	
E <sub>D</sub>	Differential linearity error (10-bit mode)	V <sub>ref+</sub> reference	2.4 V to 3.6 V	-1		1	LSB
	Differential linearity error (8-bit mode)		2.0 V to 3.6 V	-1		1	
E <sub>O</sub>	Offset error (10-bit mode)	V <sub>ref+</sub> reference	2.4 V to 3.6 V	-6.5		6.5	mV
	Offset error (8-bit mode)		2.0 V to 3.6 V	-6.5		6.5	
E <sub>G</sub>	Gain error (10-bit mode)	V <sub>ref+</sub> as reference	2.4 V to 3.6 V	-2.0		2.0	LSB
		Internal 1.5-V reference		-3.0%		3.0%	
	Gain error (8-bit mode)	V <sub>ref+</sub> as reference	2.0 V to 3.6 V	-2.0		2.0	LSB
		Internal 1.5-V reference		-3.0%		3.0%	
E <sub>T</sub>	Total unadjusted error (10-bit mode)	V <sub>ref+</sub> as reference	2.4 V to 3.6 V	-2.0		2.0	LSB
		Internal 1.5-V reference		-3.0%		3.0%	
	Total unadjusted error (8-bit mode)	V <sub>ref+</sub> as reference	2.0 V to 3.6 V	-2.0		2.0	LSB
		Internal 1.5-V reference		-3.0%		3.0%	
V <sub>SENSOR</sub>	See (1)	ADCON = 1, INCH = 0Ch, T <sub>A</sub> = 0°C	3 V		913		mV
TC <sub>SENSOR</sub>	See (2)	ADCON = 1, INCH = 0Ch	3 V		3.35		mV/°C
t <sub>SENSOR</sub> (sample)	Sample time required if channel 12 is selected <sup>(3)</sup>	ADCON = 1, INCH = 0Ch, Error of conversion result ≤ 1 LSB, AM and all LPMs above LPM3	3 V		30		μs
		ADCON = 1, INCH = 0Ch, Error of conversion result ≤ 1 LSB, LPM3	3 V		100		

- (1) The temperature sensor offset can vary significantly. TI recommends a single-point calibration to minimize the offset error of the built-in temperature sensor.
- (2) The device descriptor structure contains calibration values for 30°C and 85°C for each available reference voltage level. The sensor voltage can be computed as  $V_{SENSE} = TC_{SENSOR} \times (\text{Temperature, } ^\circ\text{C}) + V_{SENSOR}$ , where TC<sub>SENSOR</sub> and V<sub>SENSOR</sub> can be computed from the calibration values for higher accuracy.
- (3) The typical equivalent impedance of the sensor is 700 kΩ. The sample time required includes the sensor on time, t<sub>SENSOR(on)</sub>.

## 8.12.9 FRAM

节 8.12.9.1 lists the characteristics of the FRAM.

### 8.12.9.1 FRAM

over recommended ranges of supply voltage and operating free-air temperature (unless otherwise noted)

PARAMETER	TEST CONDITIONS	MIN	TYP	MAX	UNIT
Read and write endurance		10 <sup>15</sup>			cycles
t <sub>Retention</sub> Data retention duration	T <sub>J</sub> = 25°C	100			years
	T <sub>J</sub> = 70°C	40			
	T <sub>J</sub> = 85°C	10			
I <sub>WRITE</sub> Current to write into FRAM			I <sub>READ</sub> <sup>(1)</sup>		nA
I <sub>ERASE</sub> Erase current			N/A <sup>(2)</sup>		nA
t <sub>WRITE</sub> Write time			t <sub>READ</sub> <sup>(3)</sup>		ns
t <sub>READ</sub> Read time	NWAITSx = 0		1 / f <sub>SYSTEM</sub> <sup>(4)</sup>		ns
	NWAITSx = 1		2 / f <sub>SYSTEM</sub> <sup>(4)</sup>		

- (1) Writing to FRAM does not require a setup sequence or additional power when compared to reading from FRAM. The FRAM read current I<sub>READ</sub> is included in the active mode current consumption parameter I<sub>AM,FRAM</sub>.
- (2) FRAM does not require a special erase sequence.
- (3) Writing into FRAM is as fast as reading.
- (4) The maximum read (and write) speed is specified by f<sub>SYSTEM</sub> using the appropriate wait state settings (NWAITSx).

## 8.12.10 Debug and Emulation

节 8.12.10.1 lists the characteristics of the 2-wire SBW interface.

### 8.12.10.1 JTAG, Spy-Bi-Wire Interface

over recommended ranges of supply voltage and operating free-air temperature (unless otherwise noted) (see 图 8-18)

PARAMETER		V <sub>CC</sub>	MIN	TYP	MAX	UNIT
f <sub>SBW</sub>	Spy-Bi-Wire input frequency	2 V, 3 V	0		8	MHz
t <sub>SBW,Low</sub>	Spy-Bi-Wire low clock pulse duration	2 V, 3 V	0.028		15	µs
t <sub>SU, SBWTDIO</sub>	SBWTDIO setup time (before falling edge of SBWTCK in TMS and TDI slot, Spy-Bi-Wire)	2 V, 3 V	4			ns
t <sub>HD, SBWTDIO</sub>	SBWTDIO hold time (after rising edge of SBWTCK in TMS and TDI slot, Spy-Bi-Wire)	2 V, 3 V	19			ns
t <sub>Valid, SBWTDIO</sub>	SBWTDIO data valid time (after falling edge of SBWTCK in TDO slot, Spy-Bi-Wire)	2 V, 3 V			31	ns
t <sub>SBW,En</sub>	Spy-Bi-Wire enable time (TEST high to acceptance of first clock edge) <sup>(1)</sup>	2 V, 3 V			110	µs
t <sub>SBW,Ret</sub>	Spy-Bi-Wire return to normal operation time <sup>(2)</sup>	2 V, 3 V	15		100	µs
R <sub>internal</sub>	Internal pulldown resistance on TEST	2 V, 3 V	20	35	50	kΩ

- (1) Tools that access the Spy-Bi-Wire interface must wait for the t<sub>SBW,En</sub> time after pulling the TEST/SBWTCK pin high before applying the first SBWTCK clock edge.
- (2) Maximum t<sub>SBW,Ret</sub> time after pulling or releasing the TEST/SBWTCK pin low until the Spy-Bi-Wire pins revert from their Spy-Bi-Wire function to their application function. This time applies only if the Spy-Bi-Wire mode is selected.



图 8-18. JTAG Spy-Bi-Wire Timing

节 8.12.10.2 lists the characteristics of the 4-wire JTAG interface.

### 8.12.10.2 JTAG, 4-Wire Interface

over recommended ranges of supply voltage and operating free-air temperature (unless otherwise noted) (see 图 8-19)

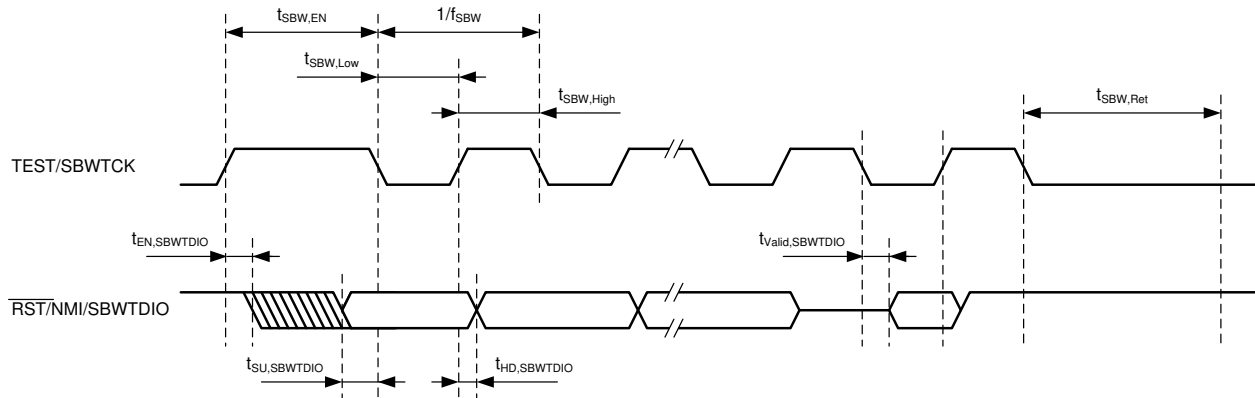
PARAMETER		V <sub>CC</sub>	MIN	TYP	MAX	UNIT
f <sub>TCK</sub>	TCK input frequency <sup>(1)</sup>	2 V, 3 V	0		10	MHz
t <sub>TCK,Low</sub>	TCK low clock pulse duration	2 V, 3 V	15			ns
t <sub>TCK,High</sub>	TCK high clock pulse duration	2 V, 3 V	15			ns
t <sub>SU,TMS</sub>	TMS setup time (before rising edge of TCK)	2 V, 3 V	11			ns
t <sub>HD,TMS</sub>	TMS hold time (after rising edge of TCK)	2 V, 3 V	3			ns
t <sub>SU,TDI</sub>	TDI setup time (before rising edge of TCK)	2 V, 3 V	13			ns
t <sub>HD,TDI</sub>	TDI hold time (after rising edge of TCK)	2 V, 3 V	5			ns
t <sub>Z-Valid,TDO</sub>	TDO high impedance to valid output time (after falling edge of TCK)	2 V, 3 V			26	ns
t <sub>Valid,TDO</sub>	TDO to new valid output time (after falling edge of TCK)	2 V, 3 V			26	ns
t <sub>Valid-Z,TDO</sub>	TDO valid to high-impedance output time (after falling edge of TCK)	2 V, 3 V			26	ns
t <sub>JTAG,Ret</sub>	Spy-Bi-Wire return to normal operation time		15		100	μs
R <sub>internal</sub>	Internal pull-down resistance on TEST	2 V, 3 V	20	35	50	kΩ

(1) f<sub>TCK</sub> may be restricted to meet the timing requirements of the module selected.



图 8-19. JTAG 4-Wire Timing

## 9 Detailed Description

### 9.1 Overview

The MSP430FR2422 is an ultra-low-power MCU. The architecture, combined with extensive low-power modes, is optimized to achieve extended battery life in, for example, portable measurement applications. The MCU features two 16-bit timers, two eUSCs that support UART, SPI, and I<sup>2</sup>C, a hardware multiplier, an RTC module, and a high-performance 10-bit ADC.

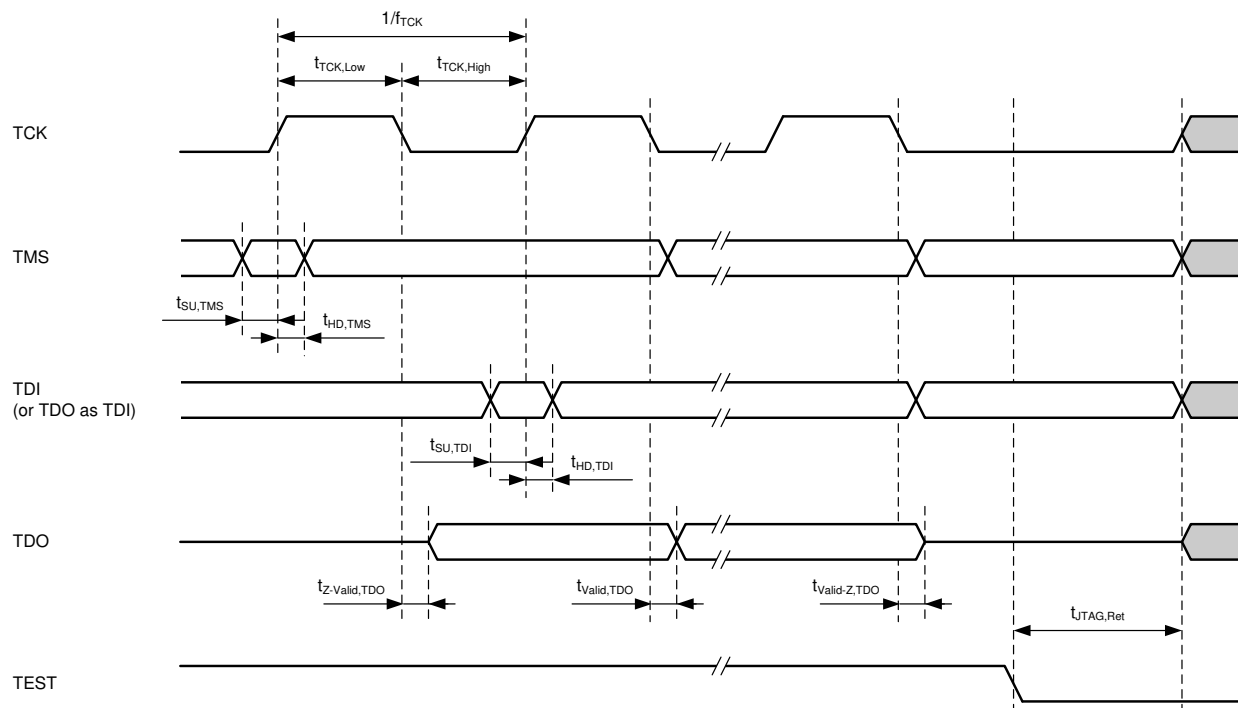
### 9.2 CPU

The MSP430 CPU has a 16-bit RISC architecture that is highly transparent to the application. All operations, other than program-flow instructions, are performed as register operations in conjunction with seven addressing modes for source operand and four addressing modes for destination operand.

The CPU is integrated with 16 registers that provide reduced instruction execution time. The register-to-register operation execution time is one cycle of the CPU clock.

Four of the registers, R0 to R3, are dedicated as program counter (PC), stack pointer (SP), status register (SR), and constant generator (CG), respectively. The remaining registers are general-purpose registers.

Peripherals are connected to the CPU using data, address, and control buses. Peripherals can be handled with all instructions.

### 9.3 Operating Modes

The MSP430 has one active mode and several software-selectable low-power modes of operation (see [表 9-1](#)). An interrupt event can wake the MCU from low-power mode LPM0, LPM3 or LPM4, service the request, and restore the MCU back to the low-power mode on return from the interrupt program. Low-power modes LPM3.5 and LPM4.5 disable the core supply to minimize power consumption.

---

#### Note

XT1CLK and VLOCLK can be active during LPM4 mode if requested by low-frequency peripherals, such as RTC and WDT.

---

表 9-1. Operating Modes

MODE		AM	LPM0	LPM3	LPM4	LPM3.5	LPM4.5
		ACTIVE MODE (FRAM ON)	CPU OFF	STANDBY	OFF	ONLY RTC	SHUTDOWN
Maximum system clock		16 MHz	16 MHz	40 kHz	0	40 kHz	0
Power consumption at 25°C, 3 V		126 $\mu$ A/MHz	40 $\mu$ A/MHz	1.2 $\mu$ A with RTC counter only in LFXT	0.49 $\mu$ A without SVS	0.73 $\mu$ A with RTC counter only in LFXT	16 nA without SVS
Wake-up time		N/A	Instant	10 $\mu$ s	10 $\mu$ s	350 $\mu$ s	350 $\mu$ s
Wake-up events		N/A	All	All	I/O	RTC I/O	I/O
Power	Regulator	Full Regulation	Full Regulation	Partial Power Down	Partial Power Down	Partial Power Down	Power Down
	SVS	On	On	Optional	Optional	Optional	Optional
	Brownout	On	On	On	On	On	On
Clock <sup>(2)</sup>	MCLK	Active	Off	Off	Off	Off	Off
	SMCLK	Optional	Optional	Off	Off	Off	Off
	FLL	Optional	Optional	Off	Off	Off	Off
	DCO	Optional	Optional	Off	Off	Off	Off
	MODCLK	Optional	Optional	Off	Off	Off	Off
	REFO	Optional	Optional	Optional	Off	Off	Off
	ACLK	Optional	Optional	Optional	Off	Off	Off
	XT1CLK	Optional	Optional	Optional	Off	Optional	Off
Core	VLOCLK	Optional	Optional	Optional	Off	Optional	Off
	CPU	On	Off	Off	Off	Off	Off
	FRAM	On	On	Off	Off	Off	Off
	RAM	On	On	On	On	Off	Off
Peripherals	Backup memory <sup>(1)</sup>	On	On	On	On	On	Off
	Timer0_A3	Optional	Optional	Optional	Off	Off	Off
	Timer1_A3	Optional	Optional	Optional	Off	Off	Off
	WDT	Optional	Optional	Optional	Off	Off	Off
	eUSCI_A0	Optional	Optional	Optional	Off	Off	Off
	eUSCI_B0	Optional	Optional	Optional	Off	Off	Off
	CRC	Optional	Optional	Off	Off	Off	Off
	ADC	Optional	Optional	Optional	Off	Off	Off
I/O	RTC	Optional	Optional	Optional	Off	Optional	Off
	General-purpose digital input/output	On	Optional	State Held	State Held	State Held	State Held

(1) Backup memory contains 32 bytes of register space in peripheral memory. See 表 9-20 and 表 9-35 for its memory allocation.

(2) The status shown for LPM4 applies to internal clocks only.

## 9.4 Interrupt Vector Addresses

The interrupt vectors and the power-up start address are in the address range 0FFFFh to 0FF80h (see 表 9-2). The vector contains the 16-bit address of the appropriate interrupt-handler instruction sequence.

表 9-2. Interrupt Sources, Flags, and Vectors

INTERRUPT SOURCE	INTERRUPT FLAG	SYSTEM INTERRUPT	WORD ADDRESS	PRIORITY
<b>System Reset</b> Power up, Brownout, Supply supervisor External reset RST Watchdog time-out, Key violation FRAM uncorrectable bit error detection Software POR, BOR FLL unlock error	SVSHIFG PMMRSTIFG WDTIFG PMMPORIFG, PMMBORIFG SYSRSTIV FLLUNLOCKIFG	Reset	FFFEh	63, Highest
<b>System NMI</b> Vacant memory access JTAG mailbox FRAM access time error FRAM bit error detection	VMAIFG JMBINIFG, JMBOUTIFG CBDIFG, UBDIFG	Nonmaskable	FFFCh	62
<b>User NMI</b> External NMI Oscillator fault	NMIIFG OFIFG	Nonmaskable	FFFAh	61
Timer0_A3	TA0CCR0 CCIFG0	Maskable	FFF8h	60
Timer0_A3	TA0CCR1 CCIFG1, TA0CCR2 CCIFG2, TA0IFG (TA0IV)	Maskable	FFF6h	59
Timer1_A3	TA1CCR0 CCIFG0	Maskable	FFF4h	58
Timer1_A3	TA1CCR1 CCIFG1, TA1CCR2 CCIFG2, TA1IFG (TA1IV)	Maskable	FFF2h	57
RTC	RTCIFG	Maskable	FFF0h	56
Watchdog timer interval mode	WDTIFG	Maskable	FFEEh	55
eUSCI_A0 receive or transmit	UCTXCPTIFG, UCSTTIFG, UCRXIFG, UCTXIFG (UART mode) UCRXIFG, UCTXIFG (SPI mode) (UCA0IV)	Maskable	FFECh	54
eUSCI_B0 receive or transmit	UCB0RXIFG, UCB0TXIFG (SPI mode) UCALIFG, UCNACKIFG, UCSTTIFG, UCSTPIFG, UCRXIFG0, UCTXIFG0, UCRXIFG1, UCTXIFG1, UCRXIFG2, UCTXIFG2, UCRXIFG3, UCTXIFG3, UCCNTIFG, UCBIT9IFG (I <sup>2</sup> C mode) (UCB0IV)	Maskable	FFEAh	53
ADC	ADCIFG0, ADCINIFG, ADCLOIFG, ADCHIIFG, ADCTOVIFG, ADCOVIFG (ADCIV)	Maskable	FFE8h	52
P1	P1IFG.0 to P1IFG.7 (P1IV)	Maskable	FFE6h	51
P2	P2IFG.0 to P2IFG.6 (P2IV)	Maskable	FFE4h	50
Reserved	Reserved	Maskable	FFE0h - FF88h	

表 9-3. Signatures

SIGNATURE	WORD ADDRESS
BSL Signature2	0FF86h
BSL Signature1	0FF84h
JTAG Signature2	0FF82h
JTAG Signature1	0FF80h

## 9.5 Bootloader (BSL)

The BSL lets users program the FRAM or RAM using either the UART serial interface or the I<sup>2</sup>C interface. Access to the MCU memory through the BSL is protected by an user-defined password. Use of the BSL requires four pins (see [表 9-4](#) and [表 9-5](#)). The BSL entry requires a specific entry sequence on the  $\overline{\text{RST}}/\text{NMI}/\text{SBWTDIO}$  and  $\text{TEST}/\text{SBWTCK}$  pins. This device can support the blank device detection automatically to invoke the BSL with bypass this special entry sequence for saving time and on board programmable. For the complete description of the feature of the BSL, see the [MSP430 FRAM Device Bootloader \(BSL\) User's Guide](#).

**表 9-4. UART BSL Pin Requirements and Functions**

DEVICE SIGNAL	BSL FUNCTION
$\overline{\text{RST}}/\text{NMI}/\text{SBWTDIO}$	Entry sequence signal
$\text{TEST}/\text{SBWTCK}$	Entry sequence signal
P1.4	Data transmit
P1.5	Data receive
DVCC	Power supply
DVSS	Ground supply

**表 9-5. I<sup>2</sup>C BSL Pin Requirements and Functions**

DEVICE SIGNAL	BSL FUNCTION
$\overline{\text{RST}}/\text{NMI}/\text{SBWTDIO}$	Entry sequence signal
$\text{TEST}/\text{SBWTCK}$	Entry sequence signal
P1.2	Data transmit and receive
P1.3	Clock
DVCC	Power supply
DVSS	Ground supply

## 9.6 JTAG Standard Interface

The MSP low-power microcontrollers support the standard JTAG interface, which requires four signals for sending and receiving data. The JTAG signals are shared with general-purpose I/O. The  $\text{TEST}/\text{SBWTCK}$  pin enables the JTAG signals. In addition to these signals, the  $\overline{\text{RST}}/\text{NMI}/\text{SBWTDIO}$  is required to interface with MSP430 development tools and device programmers. [表 9-6](#) lists the JTAG pin requirements. For further details on interfacing to development tools and device programmers, see the [MSP430 Hardware Tools User's Guide](#). For details on using the JTAG interface, see [MSP430 Programming With the JTAG Interface](#).

**表 9-6. JTAG Pin Requirements and Function**

DEVICE SIGNAL	DIRECTION	JTAG FUNCTION
P1.4/.../TCK	IN	JTAG clock input
P1.5/.../TMS	IN	JTAG state control
P1.6/.../TDI/TCLK	IN	JTAG data input, TCLK input
P1.7/.../TDO	OUT	JTAG data output
$\text{TEST}/\text{SBWTCK}$	IN	Enable JTAG pins
$\overline{\text{RST}}/\text{NMI}/\text{SBWTDIO}$	IN	External reset
DVCC	-	Power supply
DVSS	-	Ground supply

## 9.7 Spy-Bi-Wire Interface (SBW)

The MSP low-power microcontrollers support the 2-wire SBW interface. SBW can be used to interface with MSP development tools and device programmers. 表 9-7 lists the SBW interface pin requirements. For further details on interfacing to development tools and device programmers, see the [MSP430 Hardware Tools User's Guide](#). For details on using the SBW interface, see the [MSP430 Programming With the JTAG Interface](#).

**表 9-7. Spy-Bi-Wire Pin Requirements and Functions**

DEVICE SIGNAL	DIRECTION	SBW FUNCTION
TEST/SBWTCK	IN	Spy-Bi-Wire clock input
RST/NMI/SBWDIO	IN, OUT	Spy-Bi-Wire data input and output
DVCC	-	Power supply
DVSS	-	Ground supply

## 9.8 FRAM

The FRAM can be programmed using the JTAG port, SBW, the BSL, or in-system by the CPU. Features of the FRAM include:

- Byte and word access capability
- Programmable wait state generation
- Error correction coding (ECC)

## 9.9 Memory Protection

The device features memory protection for user access authority and write protection, including options to:

- Secure the whole memory map to prevent unauthorized access from JTAG port or BSL, by writing JTAG and BSL signatures using the JTAG port, SBW, the BSL, or in-system by the CPU.
- Enable write protection to prevent unwanted write operation to FRAM contents by setting the control bits in the System Configuration 0 register. For detailed information, see the SYS chapter in the [MP430FR4xx and MP430FR2xx Family User's Guide](#).

## 9.10 Peripherals

Peripherals are connected to the CPU through data, address, and control buses. All peripherals can be handled by using all instructions in the memory map. For complete module description, see the [MP430FR4xx and MP430FR2xx Family User's Guide](#).

### 9.10.1 Power-Management Module (PMM)

The PMM includes an integrated voltage regulator that supplies the core voltage to the device. The PMM also includes supply voltage supervisor (SVS) and brownout protection. The brownout reset circuit (BOR) is implemented to provide the proper internal reset signal to the device during power on and power off. The SVS circuitry detects if the supply voltage drops below a user-selectable safe level. SVS circuitry is available on the primary supply.

The device contains two on-chip reference: 1.5 V for internal reference and 1.2 V for external reference.

The 1.5-V reference is internally connected to ADC channel 13. DVCC is internally connected to ADC channel 15. When DVCC is set as the reference voltage for ADC conversion, the DVCC can be easily represent as [方程式 1](#) by using ADC sampling 1.5-V reference without any external components support.

$$DVCC = (1023 \times 1.5 \text{ V}) \div 1.5\text{-V reference ADC result} \quad (1)$$

A 1.2-V reference voltage can be buffered, when EXTREFEN = 1 on PMMCTL2 register, and it can be output to P1.1/..A1/VREF+ , meanwhile the ADC channel 1 can also be selected to monitor this voltage. For more detailed information, see the [MSP430FR4xx and MSP430FR2xx Family User's Guide](#).

### 9.10.2 Clock System (CS) and Clock Distribution

The clock system includes a 32-kHz crystal oscillator (XT1), an internal very-low-power low-frequency oscillator (VLO), an integrated 32-kHz RC oscillator (REFO), an integrated internal digitally controlled oscillator (DCO) that may use frequency-locked loop (FLL) locking with internal or external 32-kHz reference clock, and an on-chip asynchronous high-speed clock (MODOSC). The clock system is designed for cost-effective designs with minimal external components. A fail-safe mechanism is included for XT1. The clock system module offers the following clock signals.

- **Main Clock (MCLK):** The system clock used by the CPU and all relevant peripherals accessed by the bus. All clock sources except MODOSC can be selected as the source with a predivider of 1, 2, 4, 8, 16, 32, 64, or 128.
- **Sub-Main Clock (SMCLK):** The subsystem clock used by the peripheral modules. SMCLK derives from the MCLK with a predivider of 1, 2, 4, or 8. This means SMCLK is always equal to or less than MCLK.
- **Auxiliary Clock (ACLK):** This clock is derived from the external XT1 clock or internal REFO clock up to 40 kHz.

All peripherals may have one or several clock sources depending on specific functionality. 表 9-8 lists the clock distribution used in this device.

表 9-8. Clock Distribution

	CLOCK SOURCE SELECT BITS	MCLK	SMCLK	ACLK	MODCLK	XT1CLK	VLOCLK	EXTERNAL PIN
Frequency Range		DC to 16 MHz	DC to 16 MHz	DC to 40 kHz	5 MHz ±10%	DC to 40 kHz	10 kHz ±50%	-
CPU	N/A	Default	-	-	-	-	-	-
FRAM	N/A	Default	-	-	-	-	-	-
RAM	N/A	Default	-	-	-	-	-	-
CRC	N/A	Default	-	-	-	-	-	-
I/O	N/A	Default	-	-	-	-	-	-
TA0	TASSEL	-	10b	01b	-	-	11b	00b (TA0CLK pin)
TA1	TASSEL	-	10b	01b	-	-	-	00b (TA1CLK pin)
eUSCI_A0	UCSSEL	-	10b or 11b	01b	-	-	-	00b (UCA0CLK pin)
eUSCI_B0	UCSSEL	-	10b or 11b	01b	-	-	-	00b (UCB0CLK pin)
WDT	WDTSSEL	-	00b	01b	-	-	10b	-
ADC	ADCSSEL	-	10b or 11b	01b	00b	-	-	-
RTC	RTCSS	-	01b <sup>(1)</sup>	01b <sup>(1)</sup>	-	10b	11b	-

(1) Controlled by the RTCKSEL bit in the SYSCFG2 register



图 9-1. Clock Distribution Block Diagram

### 9.10.3 General-Purpose Input/Output Port (I/O)

Up to 15 I/O ports are implemented.

- P1 implements 8 bits, and P2 implements 7 bits.
- All individual I/O bits are independently programmable.
- Any combination of input, output, and interrupt conditions is possible.
- Programmable pullup or pulldown on all ports.
- Edge-selectable interrupt and LPMx.5 wake-up input capability are available for P1 and P2.
- Read and write access to port-control registers is supported by all instructions.
- Ports can be accessed byte-wise or word-wise as a pair.

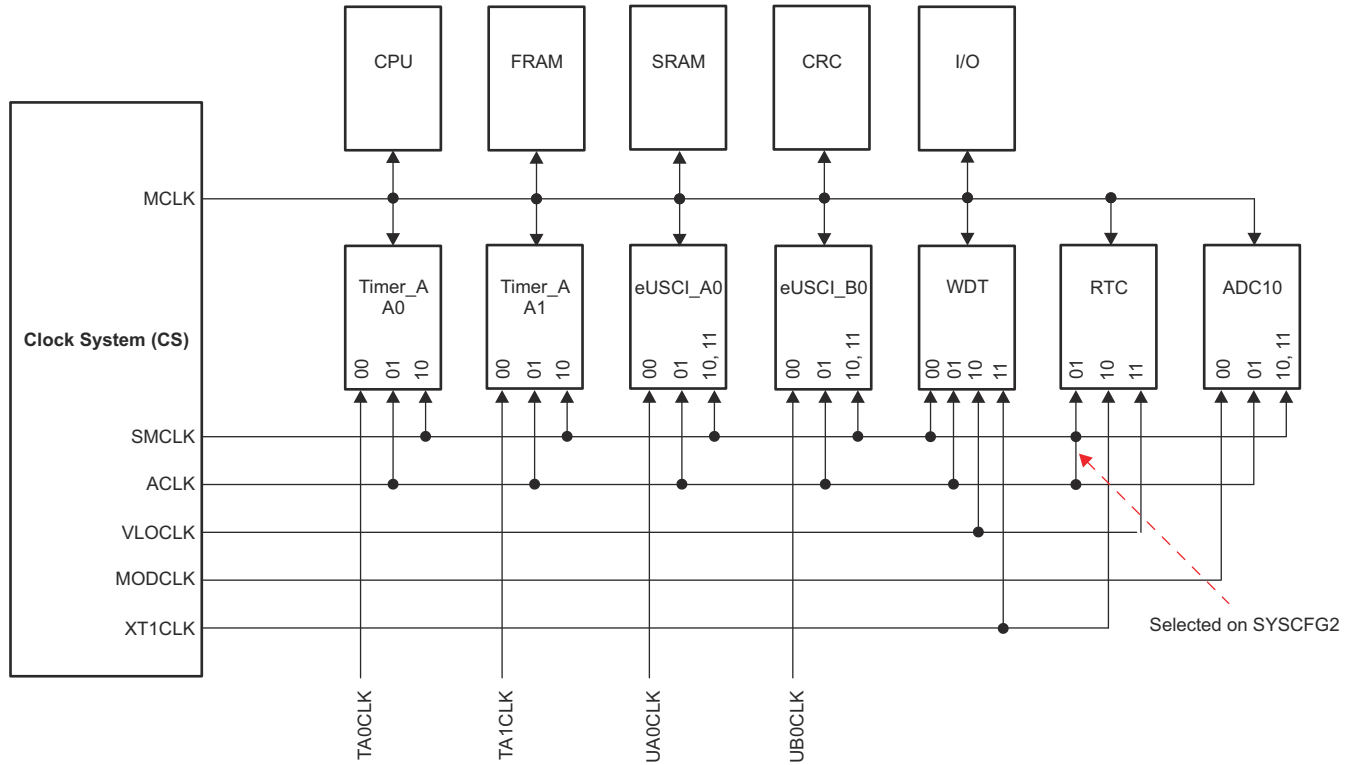
---

#### Note

##### Configuration of digital I/Os after BOR reset

To prevent any cross currents during start-up of the device, all port pins are high-impedance with Schmitt triggers and module functions disabled. To enable the I/O functions after a BOR reset, the ports must be configured first and then the LOCKLPM5 bit must be cleared. For details, see the *Configuration After Reset* section in the Digital I/O chapter of the [MP430FR4xx and MP430FR2xx Family User's Guide](#).

---

### 9.10.4 Watchdog Timer (WDT)

The primary function of the WDT module is to perform a controlled system restart after a software problem occurs. If the selected time interval expires, a system reset is generated. If the watchdog function is not needed in an application, the module can be configured as an interval timer and can generate interrupts at selected time intervals. 表 9-9 lists the system clocks that can be used to source the WDT.

表 9-9. WDT Clocks

WDTSEL	NORMAL OPERATION (WATCHDOG AND INTERVAL TIMER MODE)
00	SMCLK
01	ACLK
10	VLOCLK
11	Reserved

### 9.10.5 System (SYS) Module

The SYS module handles many of the system functions within the device. These features include power-on reset (POR) and power-up clear (PUC) handling, NMI source selection and management, reset interrupt vector generators, bootloader entry mechanisms, and configuration management (device descriptors). The SYS module also includes a data exchange mechanism through SBW called a JTAG mailbox mail box that can be used in the application. 表 9-10 summarizes the interrupts that are managed by the SYS module.

**表 9-10. System Module Interrupt Vector Registers**

INTERRUPT VECTOR REGISTER	ADDRESS	INTERRUPT EVENT	VALUE	PRIORITY
SYSRSTIV, System Reset	015Eh	No interrupt pending	00h	
		Brownout (BOR)	02h	Highest
		RSTIFG RST/NMI (BOR)	04h	
		PMMSWBOR software BOR (BOR)	06h	
		LPMx.5 wakeup (BOR)	08h	
		Security violation (BOR)	0Ah	
		Reserved	0Ch	
		SVSHIFG SVSH event (BOR)	0Eh	
		Reserved	10h	
		Reserved	12h	
		PMMSWPOR software POR (POR)	14h	
		WDTIFG watchdog time-out (PUC)	16h	
		WDTPW password violation (PUC)	18h	
		FRCTLPW password violation (PUC)	1Ah	
		Uncorrectable FRAM bit error detection	1Ch	
		Peripheral area fetch (PUC)	1Eh	
		PMMPW PMM password violation (PUC)	20h	
FLL unlock (PUC)	24h			
Reserved	22h, 26h to 3Eh	Lowest		
SYSSNIV, System NMI	015Ch	No interrupt pending	00h	
		SVS low-power reset entry	02h	Highest
		Uncorrectable FRAM bit error detection	04h	
		Reserved	06h	
		Reserved	08h	
		Reserved	0Ah	
		Reserved	0Ch	
		Reserved	0Eh	
		Reserved	10h	
		VMAIFG vacant memory access	12h	
		JMBINIFG JTAG mailbox input	14h	
		JMBOUTIFG JTAG mailbox output	16h	
		Correctable FRAM bit error detection	18h	
		Reserved	1Ah to 1Eh	Lowest
SYSUNIV, User NMI	015Ah	No interrupt pending	00h	
		NMIIFG NMI pin or SVS <sub>H</sub> event	02h	Highest
		OFIFG oscillator fault	04h	
		Reserved	06h to 1Eh	Lowest

### 9.10.6 Cyclic Redundancy Check (CRC)

The 16-bit cyclic redundancy check (CRC) module produces a signature based on a sequence of data values and can be used for data checking purposes. The CRC generation polynomial is compliant with CRC-16-CCITT standard of  $x^{16} + x^{12} + x^5 + 1$ .

### 9.10.7 Enhanced Universal Serial Communication Interface (eUSCI\_A0, eUSCI\_B0)

The eUSCI modules are used for serial data communications. The eUSCI\_A module supports either UART or SPI communications. The eUSCI\_B module supports either SPI or I<sup>2</sup>C communications. Additionally, eUSCI\_A supports automatic baud-rate detection and IrDA. The eUSCI\_A and eUSCI\_B are connected either from P1 port or P2 port, it can be selected from the USCIARMP of SYSCFG3 or USCIBRMP bit of SYSCFG2. 表 9-11 lists the pin configurations that are required for each eUSCI mode.

表 9-11. eUSCI Pin Configurations

	PIN (USCIARMP = 0)	UART	SPI
eUSCI_A0	P1.4	TXD	SIMO
	P1.5	RXD	SOMI
	P1.6	-	SCLK
	P1.7	-	STE
	PIN (USCIARMP = 1)	UART	SPI
	P2.0	TXD	SIMO
	P2.1	RXD	SOMI
	P1.6	-	SCLK
	P1.7	-	STE
	eUSCI_B0	PIN (USCIBRMP = 0)	I <sup>2</sup> C
P1.0		-	STE
P1.1		-	SCLK
P1.2		SDA	SIMO
P1.3		SCL	SOMI
PIN (USCIBRMP = 1)		I <sup>2</sup> C	SPI
P2.3		-	STE
P2.4		-	SCLK
P2.5		SDA	SIMO
P2.6		SCL	SOMI

### 9.10.8 Timers (Timer0\_A3, Timer1\_A3)

The Timer0\_A3 and Timer1\_A3 modules are 16-bit timers and counters with three capture/compare registers each. Each timer supports multiple captures or compares, PWM outputs, and interval timing (see 图 9-2). Each timer has extensive interrupt capabilities. Interrupts may be generated from the counter on overflow conditions and from each of the capture/compare registers. The CCR0 registers on both Timer0\_A3 and Timer1\_A3 are not externally connected and can only be used for hardware period timing and interrupt generation. In Up mode, they can be used to set the overflow value of the counter.



图 9-2. Timer0\_A3 and Timer1\_A3 Signal Connections

The interconnection of Timer0\_A3 and Timer1\_A3 can be used to modulate the eUSCI\_A pin of UCA0TXD/ UCA0SIMO in either ASK or FSK mode, with which a user can easily acquire a modulated infrared command for directly driving an external IR diode. The IR functions are fully controlled by SYS configuration registers 1 including IREN (enable), IRPSEL (polarity select), IRMSEL (mode select), IRDSSEL (data select), and IRDATA (data) bits. For more information, see the SYS chapter in the [MP430FR4xx and MP430FR2xx Family User's Guide](#).

### 9.10.9 Hardware Multiplier (MPY)

The multiplication operation is supported by a dedicated peripheral module. The module performs operations with 32-, 24-, 16-, and 8-bit operands. The MPY module supports signed multiplication, unsigned multiplication, signed multiply-and-accumulate, and unsigned multiply-and-accumulate operations.

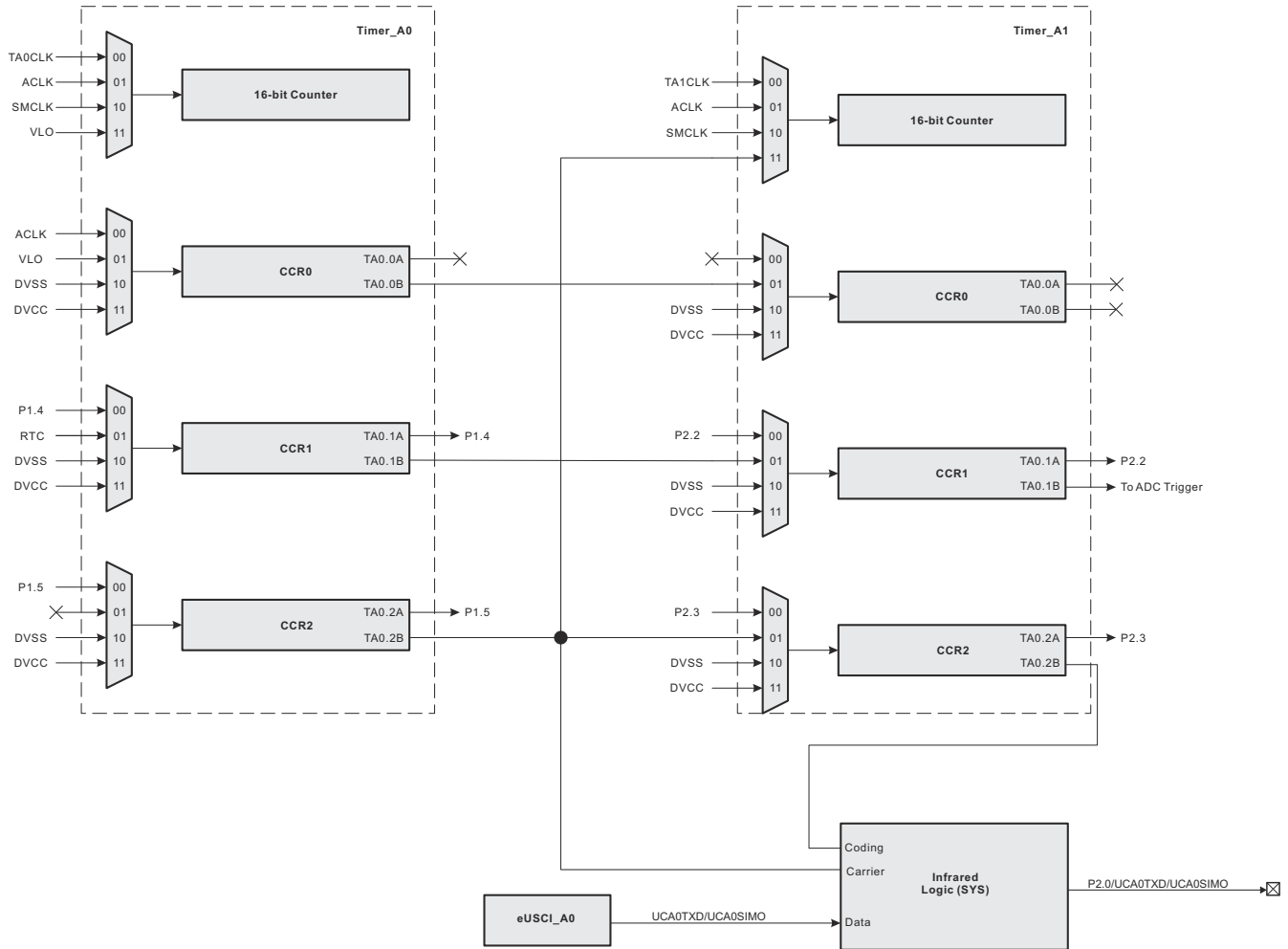
### 9.10.10 Backup Memory (BAKMEM)

The BAKMEM supports data retention during LPM3.5. This device provides up to 32 bytes that are retained during LPM3.5.

### 9.10.11 Real-Time Clock (RTC)

The RTC is a 16-bit modulo counter that is functional in AM, LPM0, LPM3, and LPM3.5. This module can periodically wake up the CPU from LPM0, LPM3, or LPM3.5 based on timing from a low-power clock source such as the XT1 and VLO clocks. RTC also can be sourced from ACLK controlled by RTCCLK in SYSCFG2. In AM, RTC can be driven by SMCLK to generate high-frequency timing events and interrupts. The RTC overflow events trigger:

- Timer0\_B3 CCI1B
- ADC conversion trigger when ADCSHSx bits are set as 01b

表 9-12. RTC Clock Source

RTCSS	CLOCK SOURCE
00	Reserved
01	SMCLK or ACLK is selected <sup>(1)</sup>
10	XT1CLK
11	VLOCLK

(1) Controlled by the RTCCLK bit of the SYSCFG2 register

### 9.10.12 10-Bit Analog-to-Digital Converter (ADC)

The 10-bit ADC module supports fast 10-bit analog-to-digital conversions with single-ended input. The module implements a 10-bit SAR core, sample select control, a reference generator, and a conversion result buffer. A window comparator with lower and upper limits allows CPU-independent result monitoring with three window comparator interrupt flags.

The ADC supports 10 external inputs and 4 internal inputs (see 表 9-13).

表 9-13. ADC Channel Connections

ADCINCH x	ADC CHANNELS	EXTERNAL PIN
0	A0/Veref+	P1.0
1	A1 <sup>(1)</sup>	P1.1
2	A2/Veref-	P1.2
3	A3	P1.3
4	A4	P2.2
5	A5	P2.3
6	A6	P2.4
7	A7	P2.5
8	Not used	N/A
9	Not used	N/A
10	Not used	N/A
11	Not used	N/A
12	On-chip temperature sensor	N/A
13	Reference voltage (1.5 V)	N/A
14	DVSS	N/A
15	DVCC	N/A

(1) When A7 is used, the PMM 1.2-V reference voltage can be output to this pin by setting the PMM control register. The 1.2-V voltage can be measured by the A1 channel.

The analog-to-digital conversion can be started by software or a hardware trigger. 表 9-14 lists the trigger sources that are available.

**表 9-14. ADC Trigger Signal Connections**

ADC <sub>SHSx</sub>		TRIGGER SOURCE
BINARY	DECIMAL	
00	0	ADCSC bit (software trigger)
01	1	RTC event
10	2	TA1.1B
11	3	Reserved

### 9.10.13 Embedded Emulation Module (EEM)

The EEM supports real-time in-system debugging. The EEM on these devices has the following features:

- Three hardware triggers or breakpoints on memory access
- One hardware trigger or breakpoint on CPU register write access
- Up to four hardware triggers can be combined to form complex triggers or breakpoints
- One cycle counter
- Clock control on module level
- EEM version: S

## 9.11 Input/Output Diagrams

### 9.11.1 Port P1 (P1.0 to P1.7) Input/Output With Schmitt Trigger

图 9-3 shows the port diagram. 表 9-15 summarizes the selection of pin function.



图 9-3. Port P1 (P1.0 to P1.7) Input/Output With Schmitt Trigger

**表 9-15. Port P1 (P1.0 to P1.7) Pin Functions**

PIN NAME (P1.x)	x	FUNCTION	CONTROL BITS AND SIGNALS <sup>(2)</sup>			
			P1DIR.x	P1SELx	ANALOG FUNCTION <sup>(1)</sup>	JTAG
P1.0/UCB0STE/A0/ Veref+	0	P1.0 (I/O)	I: 0; O: 1	00	0	0
		UCB0STE	X	01	0	0
		A0,Veref+	X	ADCPCTLx = 1 (x = 0) from SYSCFG2		N/A
P1.1/UCB0CLK/ACLK/ A1/VREF+	1	P1.1 (I/O)	I: 0; O: 1	00	0	0
		UCB0CLK	X	01	0	0
		ACLK	1	10	0	0
		A1,VREF+	X	ADCPCTLx = 1 (x = 1) from SYSCFG2		N/A
P1.2/UCB0SIMO/ UCB0SDA/SMCLK/A2/ Veref-	2	P1.2 (I/O)	I: 0; O: 1	00	0	0
		UCB0SIMO/UCB0SDA	X	01	0	0
		SMCLK	1	10	0	0
		A2, Veref-	X	ADCPCTLx = 1 (x = 2) from SYSCFG2		N/A
P1.3/UCB0SOMI/ UCB0SCL/MCLK/A3	3	P1.3 (I/O)	I: 0; O: 1	00	0	0
		UCB0SOMI/UCB0SCL	X	01	0	0
		MCLK	1	10	0	0
		A3	X	ADCPCTLx = 1 (x = 3) from SYSCFG2		N/A
P1.4/UCA0TXD/ UCA0SIMO/TA0.1/TCK	4	P1.4 (I/O)	I: 0; O: 1	00	0	Disabled
		UCA0TXD/UCA0SIMO	X	01	0	Disabled
		TA0.CCI1A	0	10	0	Disabled
		TA0.1	1			
		JTAG TCK	X	X	X	TCK
P1.5/UCA0RXD/ UCA0SOMI/TA0.2/TMS	5	P1.5 (I/O)	I: 0; O: 1	00	0	Disabled
		UCA0RXD/UCA0SOMI	X	01	0	Disabled
		TA0.CCI2A	0	10	0	Disabled
		TA0.2	1			
		JTAG TMS	X	X	X	TMS
P1.6/UCA0CLK/ TA0CLK/TDI/TCLK	6	P1.6 (I/O)	I: 0; O: 1	00	0	Disabled
		UCA0CLK	X	01	0	Disabled
		TA0CLK	0	10	0	Disabled
		JTAG TDI/TCLK	X	X	X	TDI/TCLK
P1.7/UCA0STE/TDO	7	P1.7 (I/O)	I: 0; O: 1	00	0	Disabled
		UCA0STE	X	01	0	Disabled
		JTAG TDO	X	X	X	TDO

(1) Setting the bits disables both the output driver and input Schmitt trigger to prevent leakage when analog signals are applied.

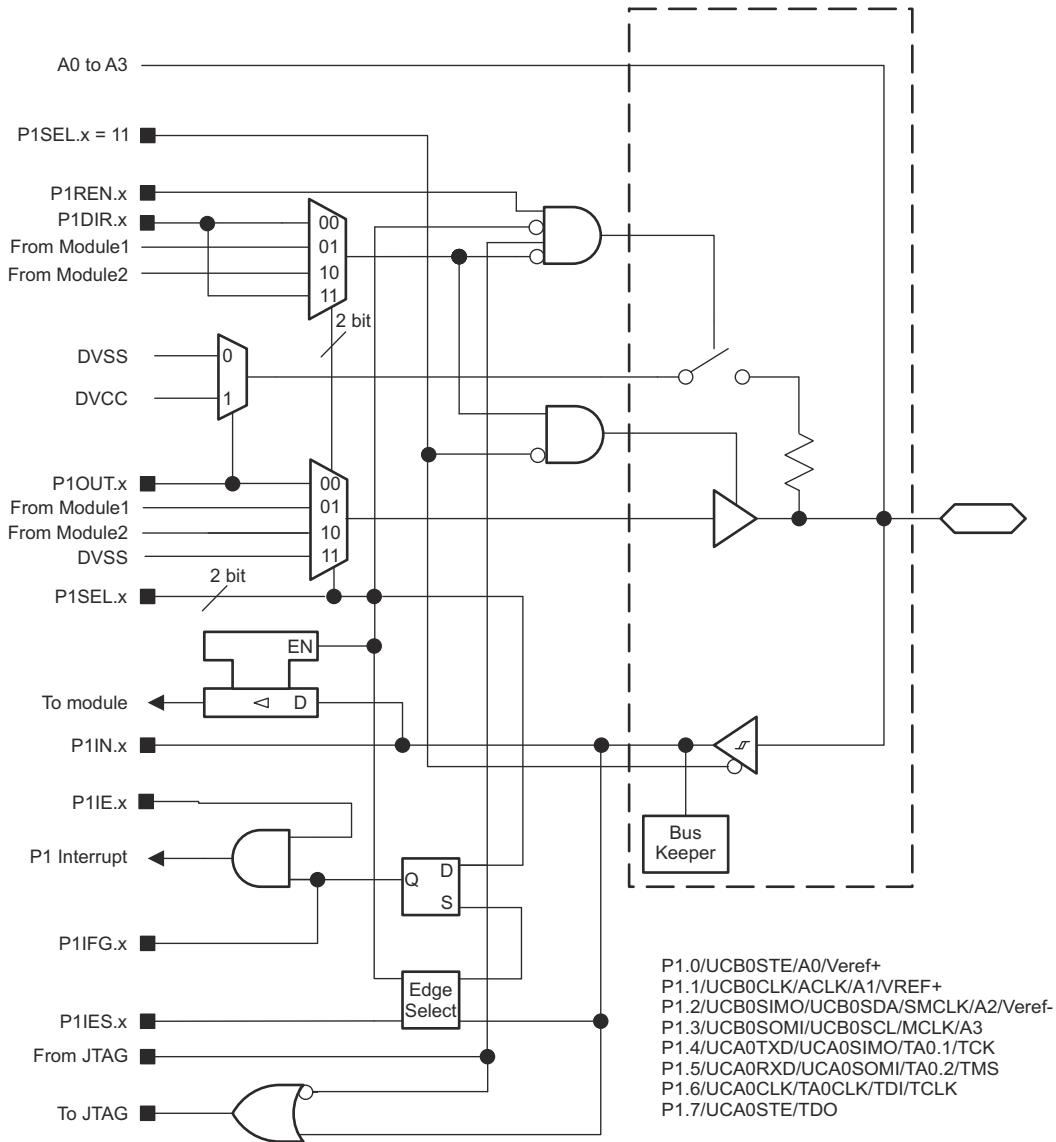
(2) X = don't care

### 9.11.2 Port P2 (P2.0 to P2.6) Input/Output With Schmitt Trigger

图 9-4 shows the port diagram. 表 9-16 summarizes the selection of pin function.



图 9-4. Port P2 (P2.0 to P2.6) Input/Output With Schmitt Trigger

表 9-16. Port P2 (P2.0 to P2.6) Pin Functions

PIN NAME (P2.x)	x	FUNCTION	CONTROL BITS AND SIGNALS <sup>(2)</sup>		
			P2DIR.x	P2SELx	ANALOG FUNCTION <sup>(1)</sup>
P2.0/UCA0TXD/ UCA0SIMO/XOUT	0	P2.0 (I/O)	I: 0; O: 1	00	0
		UCA0TXD/UCA0SIMO	X	01	0
		XOUT	X	10	0
P2.1/UCA0RXD/ UCA0SOMI/XIN	1	P2.1 (I/O)	I: 0; O: 1	00	0
		UCA0RXD/UCA0SOMI	X	01	0
		XIN	X	10	0
P2.2/TA1.1/A4	2	P2.2 (I/O)	I: 0; O: 1	00	0
		TA1.CCI1A	0	01	0
		TA1.1	1		
		A4	X	X	ADCPCTLx = 1 (x = 4) from SYSCFG2 <sup>(1)</sup>
P2.3/TA1.2/ UCB0STE/A5	3	P2.3 (I/O)	I: 0; O: 1	00	0
		TA1.CCI2A	0	01	0
		TA1.2	1		
		UCB0STE	X	10	0
		A5	X	X	ADCPCTLx = 1 (x = 5) from SYSCFG2 <sup>(1)</sup>
P2.4/TA1CLK/ UCB0CLK/A6	4	P2.4 (I/O)	I: 0; O: 1	00	0
		TA1CLK	0	01	0
		UCB0CLK	X	10	0
		A6	X	X	ADCPCTLx = 1 (x = 6) from SYSCFG2 <sup>(1)</sup>
P2.5/UCB0SIMO/ UCB0SDA/A7	5	P2.5 (I/O)	I: 0; O: 1	00	0
		UCB0SIMO/UCB0SDA	X	10	0
		A7	X	X	ADCPCTLx = 1 (x = 7) from SYSCFG2 <sup>(1)</sup>
P2.6/UCB0SOMI/ UCB0SCL	6	P2.6 (I/O)	I: 0; O: 1	00	0
		UCB0SOMI/UCB0SCL	X	10	0

## 9.12 Device Descriptors

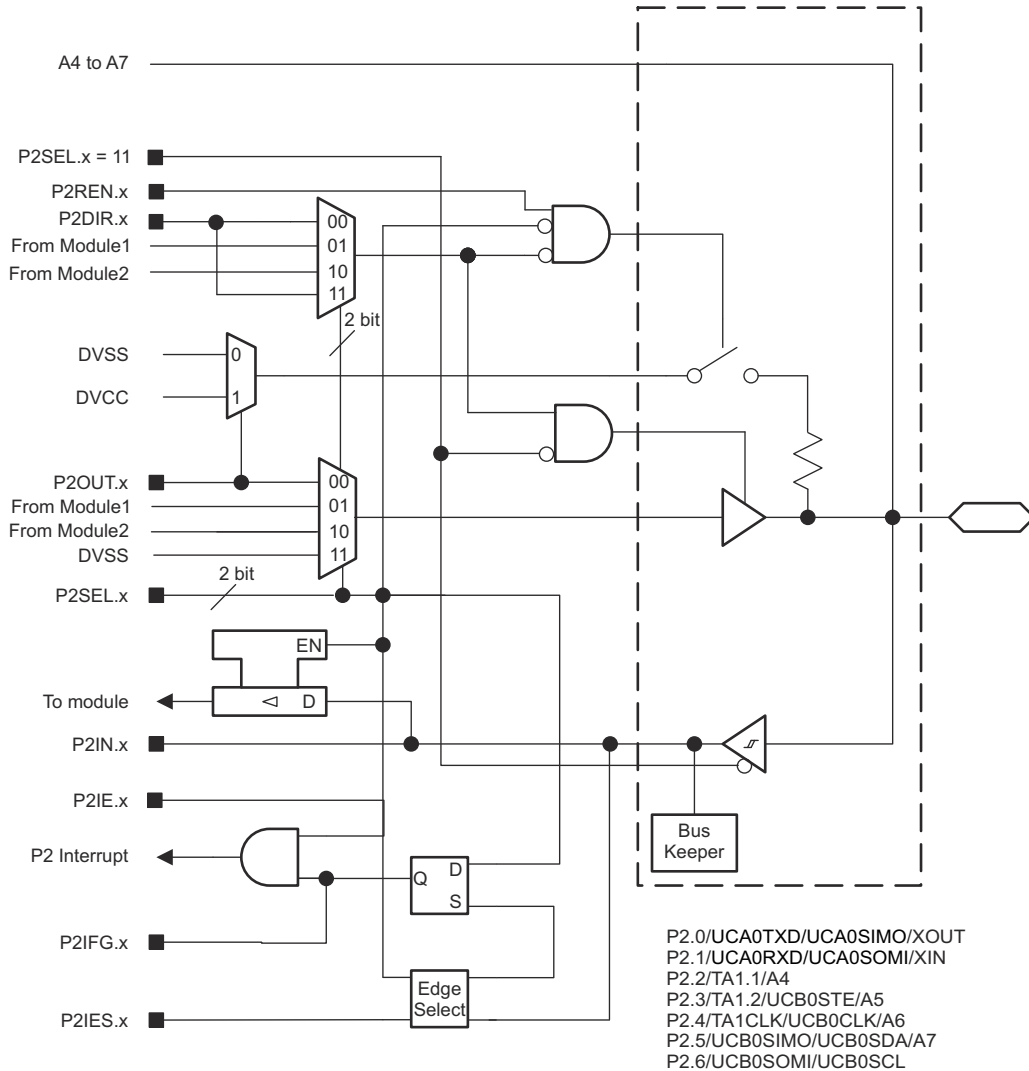
表 9-17 lists the Device IDs of the devices. 表 9-18 lists the contents of the device descriptor tag-length-value (TLV) structure for the devices.

表 9-17. Device IDs

DEVICE	DEVICE ID	
	1A05h	1A04h
MSP430FR2422	83h	11h

表 9-18. Device Descriptors

DESCRIPTION		MSP430FR2422	
		ADDRESS	VALUE
Information Block	Info length	1A00h	06h
	CRC length	1A01h	06h
	CRC value <sup>(1)</sup>	1A02h	Per unit
		1A03h	Per unit
	Device ID	1A04h	See 表 9-17.
		1A05h	
	Hardware revision	1A06h	Per unit
Firmware revision	1A07h	Per unit	
Die Record	Die record tag	1A08h	08h
	Die record length	1A09h	0Ah
	Lot wafer ID	1A0Ah	Per unit
		1A0Bh	Per unit
		1A0Ch	Per unit
		1A0Dh	Per unit
	Die X position	1A0Eh	Per unit
		1A0Fh	Per unit
	Die Y position	1A10h	Per unit
		1A11h	Per unit
Test result	1A12h	Per unit	
	1A13h	Per unit	
ADC calibration	ADC calibration tag	1A14h	Per unit
	ADC calibration length	1A15h	Per unit
	ADC gain factor	1A16h	Per unit
		1A17h	Per unit
	ADC offset	1A18h	Per unit
		1A19h	Per unit
	ADC 1.5-V reference, temperature 30°C	1A1Ah	Per unit
		1A1Bh	Per unit
ADC 1.5-V reference, temperature 85°C	1A1Ch	Per unit	
	1A1Dh	Per unit	

**表 9-18. Device Descriptors (continued)**

DESCRIPTION		MSP430FR2422	
		ADDRESS	VALUE
Reference and DCO Calibration	Calibration tag	1A1Eh	12h
	Calibration length	1A1Fh	04h
	1.5-V reference factor	1A20h	Per unit
		1A21h	Per unit
	DCO tap setting for 16 MHz, temperature 30°C <sup>(2)</sup>	1A22h	Per unit
1A23h		Per unit	

- (1) The CRC value covers the check sum from 0x1A04h to 0x1AF5h by applying the CRC-CCITT-16 polynomial of  $x^{16} + x^{12} + x^5 + 1$ .
- (2) This value can be directly loaded into DCO bits in CSCTL0 registers to get accurate 16-MHz frequency at room temperature, especially when the MCU exits from LPM3 and below. TI suggests using the predivider to decrease the frequency if the temperature drift might result an overshoot beyond 16 MHz.

## 9.13 Memory

### 9.13.1 Memory Organization

表 9-19 summarizes the memory organization of the devices.

**表 9-19. Memory Organization**

	ACCESS	MSP430FR2422
Memory (FRAM) Main: interrupt vectors and signatures Main: code memory	Read/Write (Optional Write Protect) <sup>(1)</sup>	7.25KB FFFFh to FF80h FFFFh to E300h
RAM	Read/Write	2KB 27FFh to 2000h
Information Memory (FRAM)	Read/Write (Optional Write Protect) <sup>(2)</sup>	256B 18FFh to 1800h
Bootloader (BSL1) Memory (ROM)	Read only	2KB 17FFh to 1000h
Bootloader (BSL2) Memory (ROM)	Read only	1KB FFFFh to FFC0h
Peripherals	Read/Write	4KB 0FFFh to 0000h

- (1) The Program FRAM can be write protected by setting PFWP bit in SYSCFG0 register. See the SYS chapter in the [MP430FR4xx and MP430FR2xx Family User's Guide](#) for more details
- (2) The Information FRAM can be write protected by setting DFWP bit in SYSCFG0 register. See the SYS chapter in the [MP430FR4xx and MP430FR2xx Family User's Guide](#) for more details

### 9.13.2 Peripheral File Map

表 9-20 lists the available peripherals and the register base address for each.

**表 9-20. Peripherals Summary**

MODULE NAME	BASE ADDRESS	SIZE
Special Functions (See 表 9-21)	0100h	0010h
PMM (See 表 9-22)	0120h	0020h
SYS (See 表 9-23)	0140h	0040h
CS (See 表 9-24)	0180h	0020h
FRAM (See 表 9-25)	01A0h	0010h
CRC (See 表 9-26)	01C0h	0008h
WDT (See 表 9-27)	01CCh	0002h
Port P1, P2 (See 表 9-28)	0200h	0020h
RTC (See 表 9-29)	0300h	0010h
Timer0_A3 (See 表 9-30)	0380h	0030h
Timer1_A3 (See 表 9-31)	03C0h	0030h
MPY32 (See 表 9-32)	04C0h	0030h
eUSCI_A0 (See 表 9-33)	0500h	0020h
eUSCI_B0 (See 表 9-34)	0540h	0030h
Backup Memory (See 表 9-35)	0660h	0020h
ADC (See 表 9-36)	0700h	0040h

**表 9-21. Special Function Registers (Base Address: 0100h)**

REGISTER DESCRIPTION	ACRONYM	OFFSET
SFR interrupt enable	SFRIE1	00h
SFR interrupt flag	SFRIFG1	02h
SFR reset pin control	SFRRPCR	04h

**表 9-22. PMM Registers (Base Address: 0120h)**

REGISTER DESCRIPTION	ACRONYM	OFFSET
PMM control 0	PMMCTL0	00h
PMM control 1	PMMCTL1	02h
PMM control 2	PMMCTL2	04h
PMM interrupt flags	PMMIFG	0Ah
PM5 control 0	PM5CTL0	10h

表 9-23. SYS Registers (Base Address: 0140h)

REGISTER DESCRIPTION	ACRONYM	OFFSET
System control	SYSCTL	00h
Bootloader configuration area	SYSBSLC	02h
JTAG mailbox control	SYSJMBC	06h
JTAG mailbox input 0	SYSJMBI0	08h
JTAG mailbox input 1	SYSJMBI1	0Ah
JTAG mailbox output 0	SYSJMBO0	0Ch
JTAG mailbox output 1	SYSJMBO1	0Eh
Bus error vector generator	SYSBERRIV	18h
User NMI vector generator	SYSUNIV	1Ah
System NMI vector generator	SYSSNIV	1Ch
Reset vector generator	SYSRSTIV	1Eh
System configuration 0	SYSCFG0	20h
System configuration 1	SYSCFG1	22h
System configuration 2	SYSCFG2	24h

表 9-24. CS Registers (Base Address: 0180h)

REGISTER DESCRIPTION	ACRONYM	OFFSET
CS control 0	CSCTL0	00h
CS control 1	CSCTL1	02h
CS control 2	CSCTL2	04h
CS control 3	CSCTL3	06h
CS control 4	CSCTL4	08h
CS control 5	CSCTL5	0Ah
CS control 6	CSCTL6	0Ch
CS control 7	CSCTL7	0Eh
CS control 8	CSCTL8	10h

表 9-25. FRAM Registers (Base Address: 01A0h)

REGISTER DESCRIPTION	ACRONYM	OFFSET
FRAM control 0	FRCTL0	00h
General control 0	GCCTL0	04h
General control 1	GCCTL1	06h

表 9-26. CRC Registers (Base Address: 01C0h)

REGISTER DESCRIPTION	ACRONYM	OFFSET
CRC data input	CRC16DI	00h
CRC data input reverse byte	CRCDIRB	02h
CRC initialization and result	CRCINIRES	04h
CRC result reverse byte	CRCRESR	06h

表 9-27. WDT Registers (Base Address: 01CCh)

REGISTER DESCRIPTION	ACRONYM	OFFSET
Watchdog timer control	WDTCTL	00h

**表 9-28. Port P1, P2 Registers (Base Address: 0200h)**

REGISTER DESCRIPTION	ACRONYM	OFFSET
Port P1 input	P1IN	00h
Port P1 output	P1OUT	02h
Port P1 direction	P1DIR	04h
Port P1 pulling enable	P1REN	06h
Port P1 selection 0	P1SEL0	0Ah
Port P1 selection 1	P1SEL1	0Ch
Port P1 interrupt vector word	P1IV	0Eh
Port P1 interrupt edge select	P1IES	18h
Port P1 complement selection	P1SELC	16h
Port P1 interrupt enable	P1IE	1Ah
Port P1 interrupt flag	P1IFG	1Ch
Port P2 input	P2IN	01h
Port P2 output	P2OUT	03h
Port P2 direction	P2DIR	05h
Port P2 pulling enable	P2REN	07h
Port P2 selection 0	P2SEL0	0Bh
Port P2 selection 1	P2SEL1	0Ch
Port P2 complement selection	P2SELC	17h
Port P2 interrupt vector word	P2IV	1Eh
Port P2 interrupt edge select	P2IES	19h
Port P2 interrupt enable	P2IE	1Bh
Port P2 interrupt flag	P2IFG	1Dh

**表 9-29. RTC Registers (Base Address: 0300h)**

REGISTER DESCRIPTION	ACRONYM	OFFSET
RTC control	RTCCTL	00h
RTC interrupt vector	RTCIV	04h
RTC modulo	RTCMOD	08h
RTC counter	RTCCNT	0Ch

**表 9-30. Timer0\_A3 Registers (Base Address: 0380h)**

REGISTER DESCRIPTION	ACRONYM	OFFSET
TA0 control	TA0CTL	00h
Capture/compare control 0	TA0CCTL0	02h
Capture/compare control 1	TA0CCTL1	04h
Capture/compare control 2	TA0CCTL2	06h
TA0 counter	TA0R	10h
Capture/compare 0	TA0CCR0	12h
Capture/compare 1	TA0CCR1	14h
Capture/compare 2	TA0CCR2	16h
TA0 expansion 0	TA0EX0	20h
TA0 interrupt vector	TA0IV	2Eh

**表 9-31. Timer1\_A3 Registers (Base Address: 03C0h)**

REGISTER DESCRIPTION	ACRONYM	OFFSET
TA1 control	TA1CTL	00h
Capture/compare control 0	TA1CCTL0	02h
Capture/compare control 1	TA1CCTL1	04h
Capture/compare control 2	TA1CCTL2	06h
TA1 counter	TA1R	10h
Capture/compare 0	TA1CCR0	12h
Capture/compare 1	TA1CCR1	14h
Capture/compare 2	TA1CCR2	16h
TA1 expansion 0	TA1EX0	20h
TA1 interrupt vector	TA1IV	2Eh

表 9-32. MPY32 Registers (Base Address: 04C0h)

REGISTER DESCRIPTION	ACRONYM	OFFSET
16-bit operand 1 - multiply	MPY	00h
16-bit operand 1 - signed multiply	MPYS	02h
16-bit operand 1 - multiply accumulate	MAC	04h
16-bit operand 1 - signed multiply accumulate	MACS	06h
16-bit operand 2	OP2	08h
16 × 16 result low word	RESLO	0Ah
16 × 16 result high word	RESHI	0Ch
16 × 16 sum extension	SUMEXT	0Eh
32-bit operand 1 - multiply low word	MPY32L	10h
32-bit operand 1 - multiply high word	MPY32H	12h
32-bit operand 1 - signed multiply low word	MPYS32L	14h
32-bit operand 1 - signed multiply high word	MPYS32H	16h
32-bit operand 1 - multiply accumulate low word	MAC32L	18h
32-bit operand 1 - multiply accumulate high word	MAC32H	1Ah
32-bit operand 1 - signed multiply accumulate low word	MACS32L	1Ch
32-bit operand 1 - signed multiply accumulate high word	MACS32H	1Eh
32-bit operand 2 - low word	OP2L	20h
32-bit operand 2 - high word	OP2H	22h
32 × 32 result 0 - least significant word	RES0	24h
32 × 32 result 1	RES1	26h
32 × 32 result 2	RES2	28h
32 × 32 result 3 - most significant word	RES3	2Ah
MPY32 control 0	MPY32CTL0	2Ch

表 9-33. eUSCI\_A0 Registers (Base Address: 0500h)

REGISTER DESCRIPTION	ACRONYM	OFFSET
eUSCI_A control word 0	UCA0CTLW0	00h
eUSCI_A control word 1	UCA0CTLW1	02h
eUSCI_A control rate 0	UCA0BR0	06h
eUSCI_A control rate 1	UCA0BR1	07h
eUSCI_A modulation control	UCA0MCTLW	08h
eUSCI_A status	UCA0STAT	0Ah
eUSCI_A receive buffer	UCA0RXBUF	0Ch
eUSCI_A transmit buffer	UCA0TXBUF	0Eh
eUSCI_A LIN control	UCA0ABCTL	10h
eUSCI_A IrDA transmit control	IUCA0IRTCTL	12h
eUSCI_A IrDA receive control	IUCA0IRRCTL	13h
eUSCI_A interrupt enable	UCA0IE	1Ah
eUSCI_A interrupt flags	UCA0IFG	1Ch
eUSCI_A interrupt vector word	UCA0IV	1Eh

**表 9-34. eUSCI\_B0 Registers (Base Address: 0540h)**

REGISTER DESCRIPTION	ACRONYM	OFFSET
eUSCI_B control word 0	UCB0CTLW0	00h
eUSCI_B control word 1	UCB0CTLW1	02h
eUSCI_B bit rate 0	UCB0BR0	06h
eUSCI_B bit rate 1	UCB0BR1	07h
eUSCI_B status word	UCB0STATW	08h
eUSCI_B byte counter threshold	UCB0TBCNT	0Ah
eUSCI_B receive buffer	UCB0RXBUF	0Ch
eUSCI_B transmit buffer	UCB0TXBUF	0Eh
eUSCI_B I2C own address 0	UCB0I2COA0	14h
eUSCI_B I2C own address 1	UCB0I2COA1	16h
eUSCI_B I2C own address 2	UCB0I2COA2	18h
eUSCI_B I2C own address 3	UCB0I2COA3	1Ah
eUSCI_B receive address	UCB0ADDRX	1Ch
eUSCI_B address mask	UCB0ADDMASK	1Eh
eUSCI_B I2C slave address	UCB0I2CSA	20h
eUSCI_B interrupt enable	UCB0IE	2Ah
eUSCI_B interrupt flags	UCB0IFG	2Ch
eUSCI_B interrupt vector word	UCB0IV	2Eh

表 9-35. Backup Memory Registers (Base Address: 0660h)

REGISTER DESCRIPTION	ACRONYM	OFFSET
Backup memory 0	BAKMEM0	00h
Backup memory 1	BAKMEM1	02h
Backup memory 2	BAKMEM2	04h
Backup memory 3	BAKMEM3	06h
Backup memory 4	BAKMEM4	08h
Backup memory 5	BAKMEM5	0Ah
Backup memory 6	BAKMEM6	0Ch
Backup memory 7	BAKMEM7	0Eh
Backup memory 8	BAKMEM8	10h
Backup memory 9	BAKMEM9	12h
Backup memory 10	BAKMEM10	14h
Backup memory 11	BAKMEM11	16h
Backup memory 12	BAKMEM12	18h
Backup memory 13	BAKMEM13	1Ah
Backup memory 14	BAKMEM14	1Ch
Backup memory 15	BAKMEM15	1Eh

表 9-36. ADC Registers (Base Address: 0700h)

REGISTER DESCRIPTION	REGISTER	OFFSET
ADC control 0	ADCCTL0	00h
ADC control 1	ADCCTL1	02h
ADC control 2	ADCCTL2	04h
ADC window comparator low threshold	ADCLO	06h
ADC window comparator high threshold	ADCHI	08h
ADC memory control 0	ADCMCTL0	0Ah
ADC conversion memory	ADCMEM0	12h
ADC interrupt enable	ADCIE	1Ah
ADC interrupt flags	ADCIFG	1Ch
ADC interrupt vector word	ADCIV	1Eh

## 9.14 Identification

### 9.14.1 Revision Identification

The device revision information is included as part of the top-side marking on the device package. The device-specific errata sheet describes these markings.

The hardware revision is also stored in the Device Descriptor structure in the Info Block section. For details on this value, see the Hardware Revision entries in [节 9.12](#).

### 9.14.2 Device Identification

The device type can be identified from the top-side marking on the device package. The device-specific errata sheet describes these markings.

A device identification value is also stored in the Device Descriptor structure in the Info Block section. For details on this value, see the Device ID entries in [节 9.12](#).

### 9.14.3 JTAG Identification

Programming through the JTAG interface, including reading and identifying the JTAG ID, is described in detail in [MSP430 Programming With the JTAG Interface](#).

## 10 Applications, Implementation, and Layout

### Note

Information in the following applications sections is not part of the TI component specification, and TI does not warrant its accuracy or completeness. TI's customers are responsible for determining suitability of components for their purposes, as well as validating and testing their design implementation to confirm system functionality.

### 10.1 Device Connection and Layout Fundamentals

This section discusses the recommended guidelines when designing with the MSP430 devices. These guidelines are to make sure that the device has proper connections for powering, programming, debugging, and optimum analog performance.

#### 10.1.1 Power Supply Decoupling and Bulk Capacitors

TI recommends connecting a combination of a 10- $\mu$ F plus a 100-nF low-ESR ceramic decoupling capacitor to the DVCC and DVSS pins. Higher-value capacitors may be used but can impact supply rail ramp-up time. Decoupling capacitors must be placed as close as possible to the pins that they decouple (within a few millimeters). Additionally, TI recommends separated grounds with a single-point connection for better noise isolation from digital-to-analog circuits on the board and to achieve high analog accuracy.



图 10-1. Power Supply Decoupling

#### 10.1.2 External Oscillator

This device supports only a low-frequency crystal (32 kHz) on the XIN and XOUT pins. External bypass capacitors for the crystal oscillator pins are required.

It is also possible to apply digital clock signals to the XIN input pin that meet the specifications of the respective oscillator if the appropriate XT1BYPASS mode is selected. In this case, the associated XOUT pin can be used for other purposes. If the XIN and XOUT pins are not used, they must be terminated according to 节 7.6.

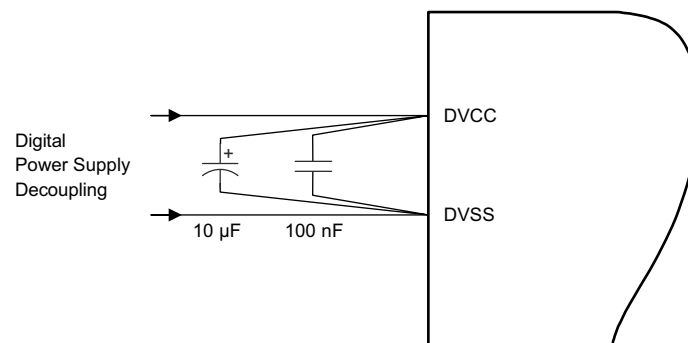
图 10-2 shows a typical connection diagram.



图 10-2. Typical Crystal Connection

See [MSP430 32-kHz Crystal Oscillators](#) for more information on selecting, testing, and designing a crystal oscillator with the MSP430 devices.

### 10.1.3 JTAG

With the proper connections, the debugger and a hardware JTAG interface (such as the MSP-FET or MSP-FET430UIF) can be used to program and debug code on the target board. In addition, the connections also support the MSP-GANG production programmers, thus providing an easy way to program prototype boards, if desired. 图 10-3 shows the connections between the 14-pin JTAG connector and the target device required to support in-system programming and debugging for 4-wire JTAG communication. 图 10-4 shows the connections for 2-wire JTAG mode (Spy-Bi-Wire).

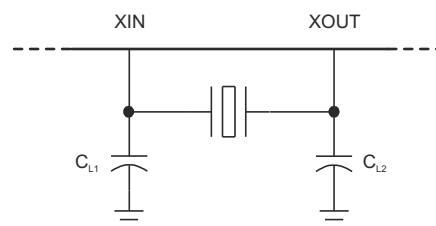
The connections for the MSP-FET and MSP-FET430UIF interface modules and the MSP-GANG are identical. Both can supply  $V_{CC}$  to the target board (through pin 2). In addition, the MSP-FET and MSP-FET430UIF interface modules and MSP-GANG have a  $V_{CC}$  sense feature that, if used, requires an alternate connection (pin 4 instead of pin 2). The  $V_{CC}$  sense feature detects the local  $V_{CC}$  present on the target board (that is, a battery or other local power supply) and adjusts the output signals accordingly. 图 10-3 and 图 10-4 show a jumper block that supports both scenarios of supplying  $V_{CC}$  to the target board. If this flexibility is not required, the desired  $V_{CC}$  connections may be hard-wired to eliminate the jumper block. Pins 2 and 4 must not be connected at the same time.

For additional design information regarding the JTAG interface, see the [MSP430 Hardware Tools User's Guide](#).

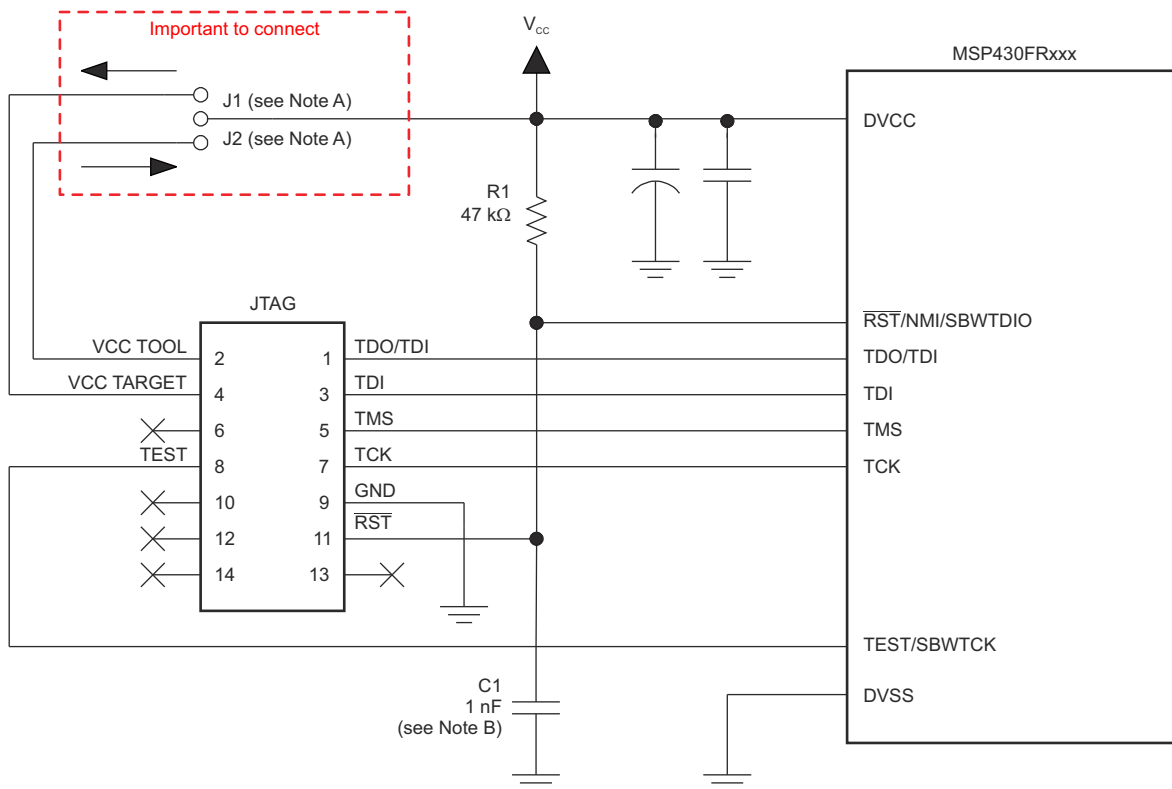

- A. If a local target power supply is used, make connection J1. If power from the debug or programming adapter is used, make connection J2.
- B. The upper limit for C1 is 1.1 nF when using current TI tools.

图 10-3. Signal Connections for 4-Wire JTAG Communication

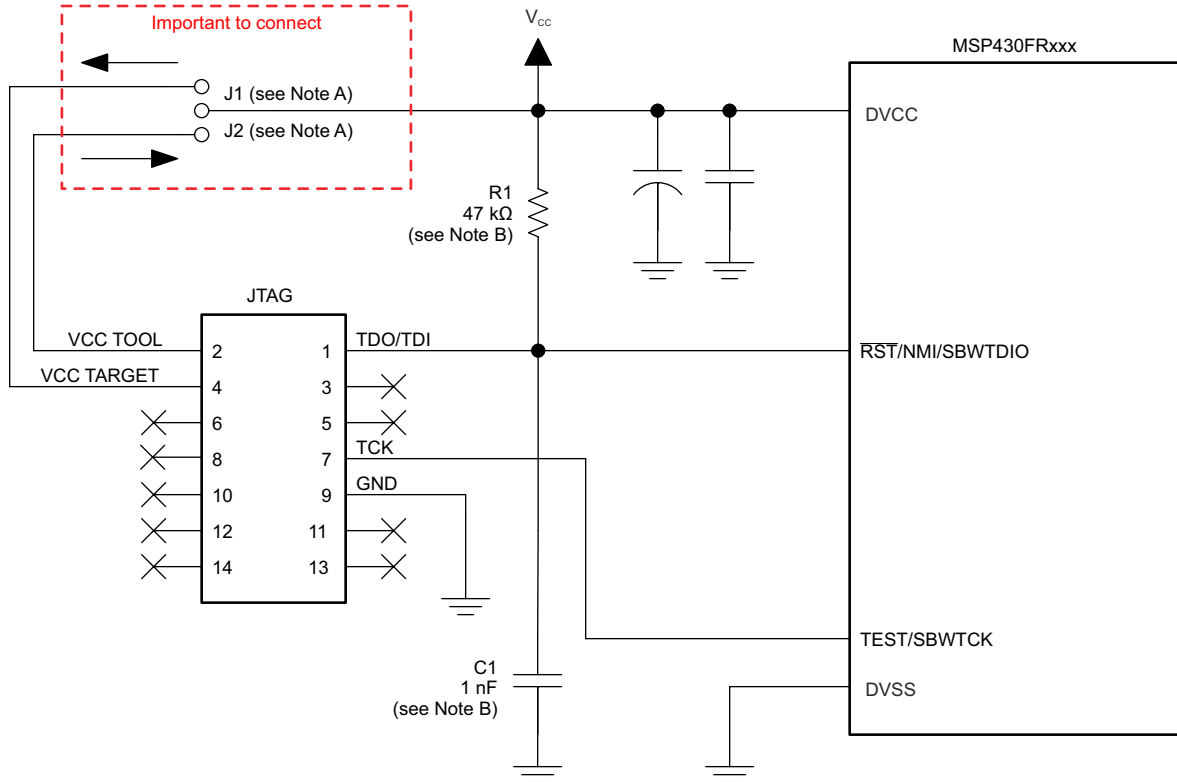

- Make connection J1 if a local target power supply is used, or make connection J2 if the target is powered from the debug or programming adapter.
- The device  $\overline{\text{RST/NMI/SBWTIO}}$  pin is used in 2-wire mode for bidirectional communication with the device during JTAG access, and any capacitance that is attached to this signal may affect the ability to establish a connection with the device. The upper limit for C1 is 1.1 nF when using current TI tools.

**图 10-4. Signal Connections for 2-Wire JTAG Communication (Spy-Bi-Wire)**

### 10.1.4 Reset

The reset pin can be configured as a reset function (default) or as an NMI function in the Special Function Register (SFR), SFRRPCR.

In reset mode, the  $\overline{\text{RST/NMI}}$  pin is active low, and a pulse applied to this pin that meets the reset timing specifications generates a BOR-type device reset.

Setting SYSNMI causes the  $\overline{\text{RST/NMI}}$  pin to be configured as an external NMI source. The external NMI is edge sensitive, and its edge is selectable by SYSNMIIES. Setting the NMIIE enables the interrupt of the external NMI. When an external NMI event occurs, the NMIIFG is set.

The  $\overline{\text{RST/NMI}}$  pin can have either a pullup or pulldown that is enabled or not. SYSRSTUP selects either pullup or pulldown, and SYSRSTRE causes the pullup (default) or pulldown to be enabled (default) or not. If the  $\overline{\text{RST/NMI}}$  pin is unused, it is required either to select and enable the internal pullup or to connect an external 47-k $\Omega$  pullup resistor to the  $\overline{\text{RST/NMI}}$  pin with a 10-nF pulldown capacitor. The pulldown capacitor should not exceed 1.1 nF when using devices with Spy-Bi-Wire interface in Spy-Bi-Wire mode or in 4-wire JTAG mode with TI tools like FET interfaces or GANG programmers.

See the [MP430FR4xx and MP430FR2xx Family User's Guide](#) for more information on the referenced control registers and bits.

### 10.1.5 Unused Pins

For details on the connection of unused pins, see [节 7.6](#).

### 10.1.6 General Layout Recommendations

- Proper grounding and short traces for external crystal to reduce parasitic capacitance. See [MSP430 32-kHz Crystal Oscillators](#) for recommended layout guidelines.
- Proper bypass capacitors on DVCC and reference pins, if used.
- Avoid routing any high-frequency signal close to an analog signal line. For example, keep digital switching signals such as PWM or JTAG signals away from the oscillator circuit.
- Proper ESD level protection should be considered to protect the device from unintended high-voltage electrostatic discharge. See [MSP430 System-Level ESD Considerations](#) for guidelines.

### 10.1.7 Do's and Don'ts

During power up, power down, and device operation, DVCC must not exceed the limits specified in [节 8.1](#). Exceeding the specified limits may cause malfunction of the device including erroneous writes to RAM and FRAM.

## 10.2 Peripheral- and Interface-Specific Design Information

### 10.2.1 ADC Peripheral

#### 10.2.1.1 Partial Schematic

[图 10-5](#) shows the recommended decoupling circuit when an external voltage reference is used.

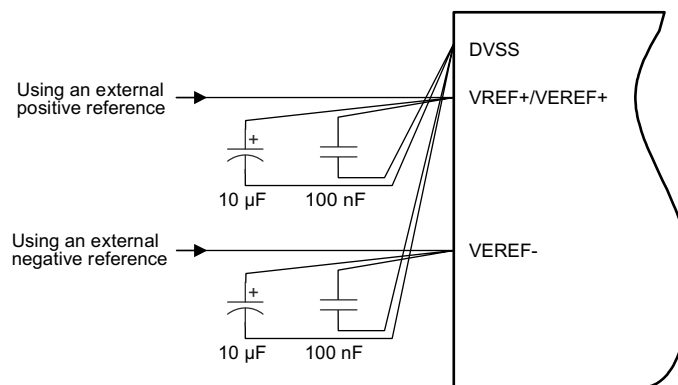

**图 10-5. ADC Grounding and Noise Considerations**

#### 10.2.1.2 Design Requirements

As with any high-resolution ADC, appropriate printed-circuit-board layout and grounding techniques should be followed to eliminate ground loops, unwanted parasitic effects, and noise.

Ground loops are formed when return current from the ADC flows through paths that are common with other analog or digital circuitry. If care is not taken, this current can generate small unwanted offset voltages that can add to or subtract from the reference or input voltages of the ADC. The general guidelines in [节 10.1.1](#) combined with the connections shown in [图 10-5](#) prevent this.

Quickly switching digital signals and noisy power supply lines can corrupt the conversion results, so keep the ADC input trace shielded from those digital and power supply lines. Putting the MCU in low-power mode during the ADC conversion improves the ADC performance in a noisy environment. If the device includes the analog power pair inputs (AVCC and AVSS), TI recommends a noise-free design using separate analog and digital ground planes with a single-point connection to achieve high accuracy.

[图 10-5](#) shows the recommended decoupling circuit when an external voltage reference is used. The internal reference module has a maximum drive current as described in the sections *ADC Pin Enable* and *1.2-V Reference Settings* of the [MSP430FR4xx and MSP430FR2xx Family User's Guide](#).

The reference voltage must be a stable voltage for accurate measurements. The capacitor values that are selected in the general guidelines filter out the high- and low-frequency ripple before the reference voltage

enters the device. In this case, the 10- $\mu$ F capacitor buffers the reference pin and filters any low-frequency ripple. A bypass capacitor of 100 nF filters out any high-frequency noise.

### **10.2.1.3 Layout Guidelines**

Components that are shown in the partial schematic (see [图 10-5](#)) should be placed as close as possible to the respective device pins to avoid long traces, because they add additional parasitic capacitance, inductance, and resistance on the signal.

Avoid routing analog input signals close to a high-frequency pin (for example, a high-frequency PWM), because the high-frequency switching can be coupled into the analog signal.

## 11 Device and Documentation Support

### 11.1 Getting Started and Next Steps

For more information on the MSP low-power microcontrollers and the tools and libraries that are available to help with your development, visit the [MSP430™ ultra-low-power sensing & measurement MCUs overview](#).

### 11.2 Device Nomenclature

To designate the stages in the product development cycle, TI assigns prefixes to the part numbers of all MSP MCU devices. Each MSP MCU commercial family member has one of two prefixes: MSP or XMS. These prefixes represent evolutionary stages of product development from engineering prototypes (XMS) through fully qualified production devices (MSP).

**XMS** - Experimental device that is not necessarily representative of the final device's electrical specifications

**MSP** - Fully qualified production device

XMS devices are shipped against the following disclaimer:

"Developmental product is intended for internal evaluation purposes."

MSP devices have been characterized fully, and the quality and reliability of the device have been demonstrated fully. TI's standard warranty applies.

Predictions show that prototype devices (XMS) have a greater failure rate than the standard production devices. TI recommends that these devices not be used in any production system because their expected end-use failure rate still is undefined. Only qualified production devices are to be used.

TI device nomenclature also includes a suffix with the device family name. This suffix indicates the temperature range, package type, and distribution format. [图 11-1](#) provides a legend for reading the complete device name.

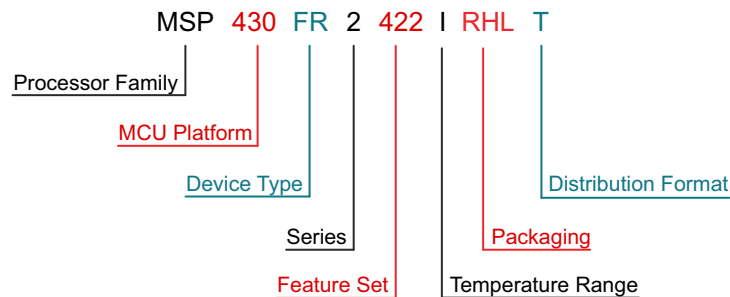

<b>Processor Family</b>	MSP = Mixed-Signal Processor XMS = Experimental Silicon	
<b>MCU Platform</b>	430 = MSP430 16-bit low-power platform	
<b>Device Type</b>	Memory Type FR = FRAM	
<b>Series</b>	2 = Up to 16 MHz without LCD	
<b>Feature Set</b>	First and Second Digits: ADC10 Channels / eUSCIs / 16-bit Timers / I/Os 42 = Up to 8 / 2 / 2 / Up to 15	Third Digit: FRAM (KB) / SRAM (KB) 2 = 8 / 2
<b>Temperature Range</b>	I = -40°C to 85°C	
<b>Packaging</b>	<a href="http://www.ti.com/packaging">www.ti.com/packaging</a>	
<b>Distribution Format</b>	T = Small reel R = Large reel No Marking = Tube or tray	

**图 11-1. Device Nomenclature**

## 11.3 Tools and Software

表 11-1 lists the debug features supported by these microcontrollers. See the [Code Composer Studio IDE for MSP430 MCUs User's Guide](#) for details on the available features.

表 11-1. Hardware Features

MSP430 ARCHITECTURE	4-WIRE JTAG	2-WIRE JTAG	BREAK-POINTS (N)	RANGE BREAK-POINTS	CLOCK CONTROL	STATE SEQUENCER	TRACE BUFFER	LPMx.5 DEBUGGING SUPPORT	EEM VERSION
MSP430Xv2	Yes	Yes	3	Yes	Yes	No	No	No	S

### Design Kits and Evaluation Modules

#### [MSP-TS430RHL20 20-Pin Target Development Board for MSP430FR2x MCUs](#)

The MSP-TS430RHL20 is a stand-alone ZIF socket target board used to program and debug the MSP430 in-system through the JTAG interface or the Spy Bi-Wire (2-wire JTAG) protocol. The development board supports all MSP430FR252x and MSP430FR242x Flash parts in a 20-pin VQFN package (TI package code: RHL).

#### [MSP-FET + MSP-TS430RHL20 FRAM Microcontroller Development Kit Bundle](#)

The MSP-FET430RHL20-BNDL bundle combines two debugging tools that support the 20-pin RHL package for the MSP430FR2422 microcontroller (for example, MSP430FR2422RHL). These two tools include MSP-TS430RHL20 and MSP-FET.

### Software

#### [MSP430Ware™ Software](#)

MSP430Ware software is a collection of code examples, data sheets, and other design resources for all MSP430 devices delivered in a convenient package. In addition to providing a complete collection of existing MSP430 design resources, MSP430Ware software also includes a high-level API called MSP430 Driver Library. This library makes it easy to program MSP430 hardware. MSP430Ware software is available as a component of CCS or as a stand-alone package.

#### [MSP430FR2422 Code Examples](#)

C Code examples are available for every MSP device that configures each of the integrated peripherals for various application needs.

#### [MSP Driver Library](#)

Driver Library's abstracted API keeps you above the bits and bytes of the MSP430 hardware by providing easy-to-use function calls. Thorough documentation is delivered through a helpful API Guide, which includes details on each function call and the recognized parameters. Developers can use Driver Library functions to write complete projects with minimal overhead.

#### [MSP EnergyTrace™ Technology](#)

EnergyTrace technology for MSP430 microcontrollers is an energy-based code analysis tool that measures and displays the application's energy profile and helps to optimize it for ultra-low-power consumption.

#### [ULP \(Ultra-Low Power\) Advisor](#)

ULP Advisor™ software is a tool for guiding developers to write more efficient code to fully utilize the unique ultra-low power features of MSP and MSP432 microcontrollers. Aimed at both experienced and new microcontroller developers, ULP Advisor checks your code against a thorough ULP checklist to squeeze every last nano amp out of your application. At build time, ULP Advisor will provide notifications and remarks to highlight areas of your code that can be further optimized for lower power.

## [FRAM Embedded Software Utilities for MSP Ultra-Low-Power Microcontrollers](#)

The FRAM Utilities is designed to grow as a collection of embedded software utilities that leverage the ultra-low-power and virtually unlimited write endurance of FRAM. The utilities are available for MSP430FRxx FRAM microcontrollers and provide example code to help start application development. Included utilities include Compute Through Power Loss (CTPL). CTPL is utility API set that enables ease of use with LPMx.5 low-power modes and a powerful shutdown mode that allows an application to save and restore critical system components when a power loss is detected.

## [IEC60730 Software Package](#)

The IEC60730 MSP430 software package was developed to be useful in assisting customers in complying with IEC 60730-1:2010 (Automatic Electrical Controls for Household and Similar Use - Part 1: General Requirements) for up to Class B products, which includes home appliances, arc detectors, power converters, power tools, e-bikes, and many others. The IEC60730 MSP430 software package can be embedded in customer applications running on MSP430s to help simplify the customer's certification efforts of functional safety-compliant consumer devices to IEC 60730-1:2010 Class B.

## [Fixed Point Math Library for MSP](#)

The MSP IQmath and Qmath Libraries are a collection of highly optimized and high-precision mathematical functions for C programmers to seamlessly port a floating-point algorithm into fixed-point code on MSP430 and MSP432 devices. These routines are typically used in computationally intensive real-time applications where optimal execution speed, high accuracy, and ultra-low energy are critical. By using the IQmath and Qmath libraries, it is possible to achieve execution speeds considerably faster and energy consumption considerably lower than equivalent code written using floating-point math.

## [Floating Point Math Library for MSP430](#)

Continuing to innovate in the low power and low cost microcontroller space, TI brings you MSPMATHLIB. Leveraging the intelligent peripherals of our devices, this floating point math library of scalar functions brings you up to 26x better performance. Mathlib is easy to integrate into your designs. This library is free and is integrated in both Code Composer Studio and IAR IDEs. Read the user's guide for an in depth look at the math library and relevant benchmarks.

## **Development Tools**

### [Code Composer Studio™ Integrated Development Environment for MSP Microcontrollers](#)

Code Composer Studio is an integrated development environment (IDE) that supports all MSP microcontroller devices. Code Composer Studio comprises a suite of embedded software utilities used to develop and debug embedded applications. It includes an optimizing C/C++ compiler, source code editor, project build environment, debugger, profiler, and many other features. The intuitive IDE provides a single user interface taking you through each step of the application development flow. Familiar utilities and interfaces allow users to get started faster than ever before. Code Composer Studio combines the advantages of the Eclipse software framework with advanced embedded debug capabilities from TI resulting in a compelling feature-rich development environment for embedded developers. When using CCS with an MSP MCU, a unique and powerful set of plugins and embedded software utilities are made available to fully leverage the MSP microcontroller.

### [Command-Line Programmer](#)

MSP Flasher is an open-source shell-based interface for programming MSP microcontrollers through a FET programmer or eZ430 using JTAG or Spy-Bi-Wire (SBW) communication. MSP Flasher can download binary files (.txt or .hex) files directly to the MSP microcontroller without an IDE.

## MSP MCU Programmer and Debugger

The MSP-FET is a powerful emulation development tool – often called a debug probe – that lets users quickly begin application development on MSP low-power microcontrollers (MCU). Creating MCU software usually requires downloading the resulting binary program to the MSP device for validation and debugging. The MSP-FET provides a debug communication pathway between a host computer and the target MSP. Furthermore, the MSP-FET also provides a backchannel UART connection between the computer's USB interface and the MSP UART. This affords the MSP programmer a convenient method for communicating serially between the MSP and a terminal running on the computer.

## MSP-GANG Production Programmer

The MSP Gang Programmer can program up to eight identical MSP430 or MSP432 flash or FRAM devices at the same time. The MSP Gang Programmer connects to a host PC using a standard RS-232 or USB connection and provides flexible programming options that allow the user to fully customize the process. The MSP Gang Programmer is provided with an expansion board, called the Gang Splitter, that implements the interconnections between the MSP Gang Programmer and multiple target devices.

## 11.4 Documentation Support

The following documents describe the MSP430FR2422 microcontrollers. Copies of these documents are available on the Internet at [www.ti.com](http://www.ti.com).

### Receiving Notification of Document Updates

To receive notification of documentation updates—including silicon errata—go to the product folder for your device on [ti.com](http://ti.com) (for example, [MSP430FR2422](http://ti.com)). In the upper right corner, click the "Alert me" button. This registers you to receive a weekly digest of product information that has changed (if any). For change details, check the revision history of any revised document.

### Errata

#### [MSP430FR2422 Device Erratasheet](#)

Describes the known exceptions to the functional specifications for all silicon revisions of this device.

### User's Guides

#### [MSP430FR4xx and MSP430FR2xx Family User's Guide](#)

Detailed description of all modules and peripherals available in this device family.

#### [MSP430 FRAM Device Bootloader \(BSL\) User's Guide](#)

The BSL can program memory during MSP430 MCU project development and updates. The BSL can be activated by a utility that sends commands using a serial protocol. The BSL enables the user to control the activity of the MSP430 device and to exchange data using a personal computer or other device.

#### [MSP430 Programming With the JTAG Interface](#)

This document describes the functions that are required to erase, program, and verify the memory module of the MSP430 flash-based and FRAM-based microcontroller families using the JTAG communication port. In addition, it describes how to program the JTAG access security fuse that is available on all MSP430 devices. This document describes device access using both the standard 4-wire JTAG interface and the 2-wire JTAG interface, which is also referred to as Spy-Bi-Wire (SBW).

## MSP430 Hardware Tools User's Guide

This manual describes the hardware of the TI MSP-FET430 Flash Emulation Tool (FET). The FET is the program development tool for the MSP430 ultra-low-power microcontroller.

### Application Reports

#### MSP430 32-kHz Crystal Oscillators

Selection of the right crystal, correct load circuit, and proper board layout are important for a stable crystal oscillator. This application report summarizes crystal oscillator function and explains the parameters to select the correct crystal for MSP430 ultra-low-power operation. In addition, hints and examples for correct board layout are given. The document also contains detailed information on the possible oscillator tests to ensure stable oscillator operation in mass production.

#### MSP430 System-Level ESD Considerations

System-level ESD has become increasingly demanding with silicon technology scaling towards lower voltages and the need for designing cost-effective and ultra-low-power components. This application report addresses different ESD topics to help board designers and OEMs understand and design robust system-level designs. A few real-world system-level ESD protection design examples and their results are also discussed.

### 11.5 支持资源

**TI E2E™ 支持论坛**是工程师的重要参考资料，可直接从专家获得快速、经过验证的解答和设计帮助。搜索现有解答或提出自己的问题可获得所需的快速设计帮助。

链接的内容由各个贡献者“按原样”提供。这些内容并不构成 TI 技术规范，并且不一定反映 TI 的观点；请参阅 TI 的《使用条款》。

### 11.6 Trademarks

MSP430™, MSP430Ware™, Code Composer Studio™, E2E™, EnergyTrace™, ULP Advisor™, TI E2E™ are trademarks of Texas Instruments.

所有商标均为其各自所有者的财产。

### 11.7 静电放电警告



静电放电 (ESD) 会损坏这个集成电路。德州仪器 (TI) 建议通过适当的预防措施处理所有集成电路。如果不遵守正确的处理和安装程序，可能会损坏集成电路。

ESD 的损坏小至导致微小的性能降级，大至整个器件故障。精密的集成电路可能更容易受到损坏，这是因为非常细微的参数更改都可能会导致器件与其发布的规格不相符。

### 11.8 Export Control Notice

Recipient agrees to not knowingly export or re-export, directly or indirectly, any product or technical data (as defined by the U.S., EU, and other Export Administration Regulations) including software, or any controlled product restricted by other applicable national regulations, received from disclosing party under nondisclosure obligations (if any), or any direct product of such technology, to any destination to which such export or re-export is restricted or prohibited by U.S. or other applicable laws, without obtaining prior authorization from U.S. Department of Commerce and other competent Government authorities to the extent required by those laws.

### 11.9 术语表

**TI 术语表** 本术语表列出并解释了术语、首字母缩略词和定义。

## **12 Mechanical, Packaging, and Orderable Information**



The following pages include mechanical, packaging, and orderable information. This information is the most current data available for the designated devices. This data is subject to change without notice and revision of this document. For browser-based versions of this data sheet, see the left-hand navigation.

**MECHANICAL DATA**

PW (R-PDSO-G16)

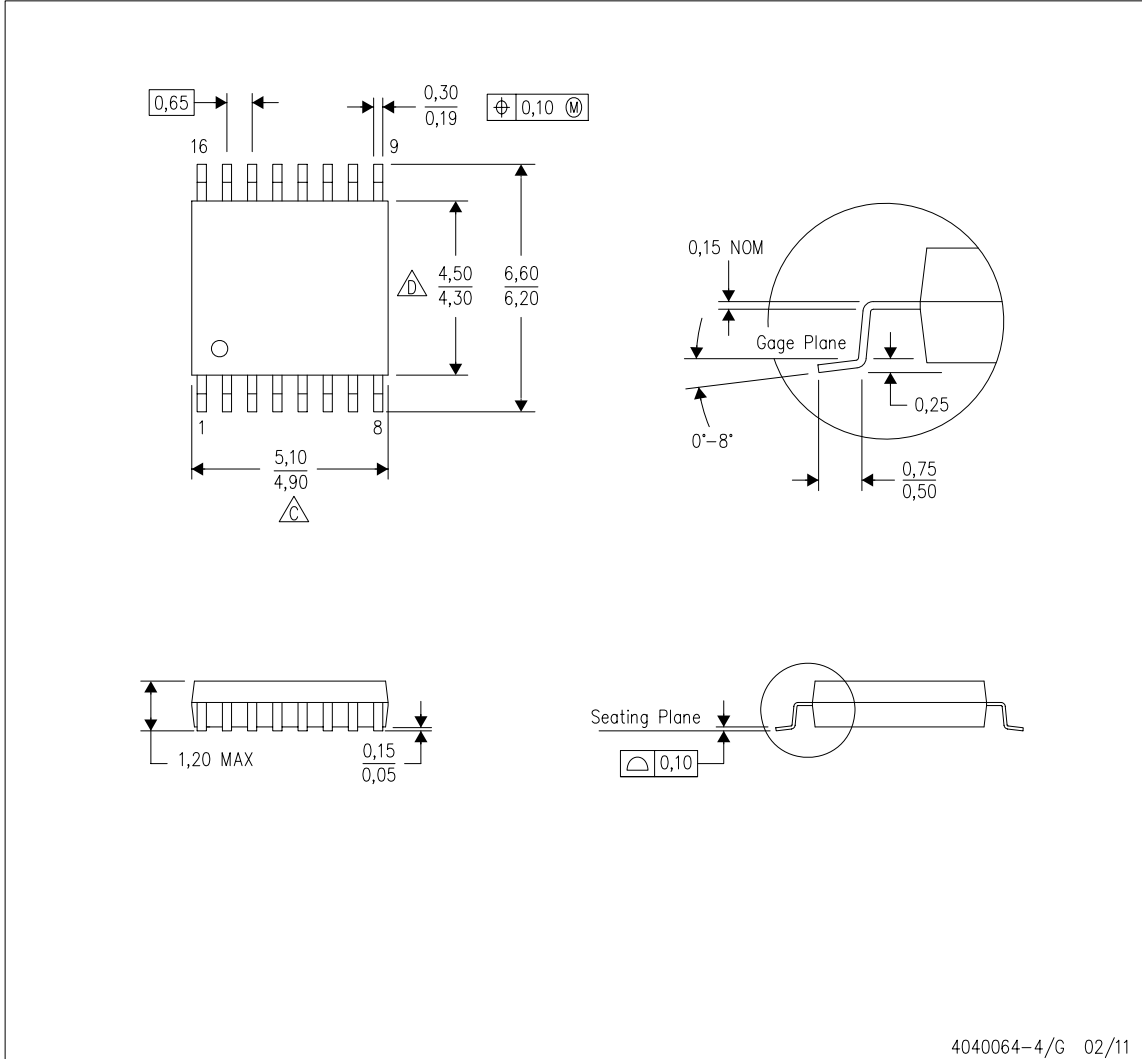
PLASTIC SMALL OUTLINE



- NOTES:
- A. All linear dimensions are in millimeters. Dimensioning and tolerancing per ASME Y14.5M-1994.
  - B. This drawing is subject to change without notice.
  -  C. Body length does not include mold flash, protrusions, or gate burrs. Mold flash, protrusions, or gate burrs shall not exceed 0,15 each side.
  -  D. Body width does not include interlead flash. Interlead flash shall not exceed 0,25 each side.
  - E. Falls within JEDEC MO-153

**PACKAGE OUTLINE**

**RH1 0020A**

**VQFN - 1 mm max height**

PLASTIC QUAD FLATPACK- NO LEAD

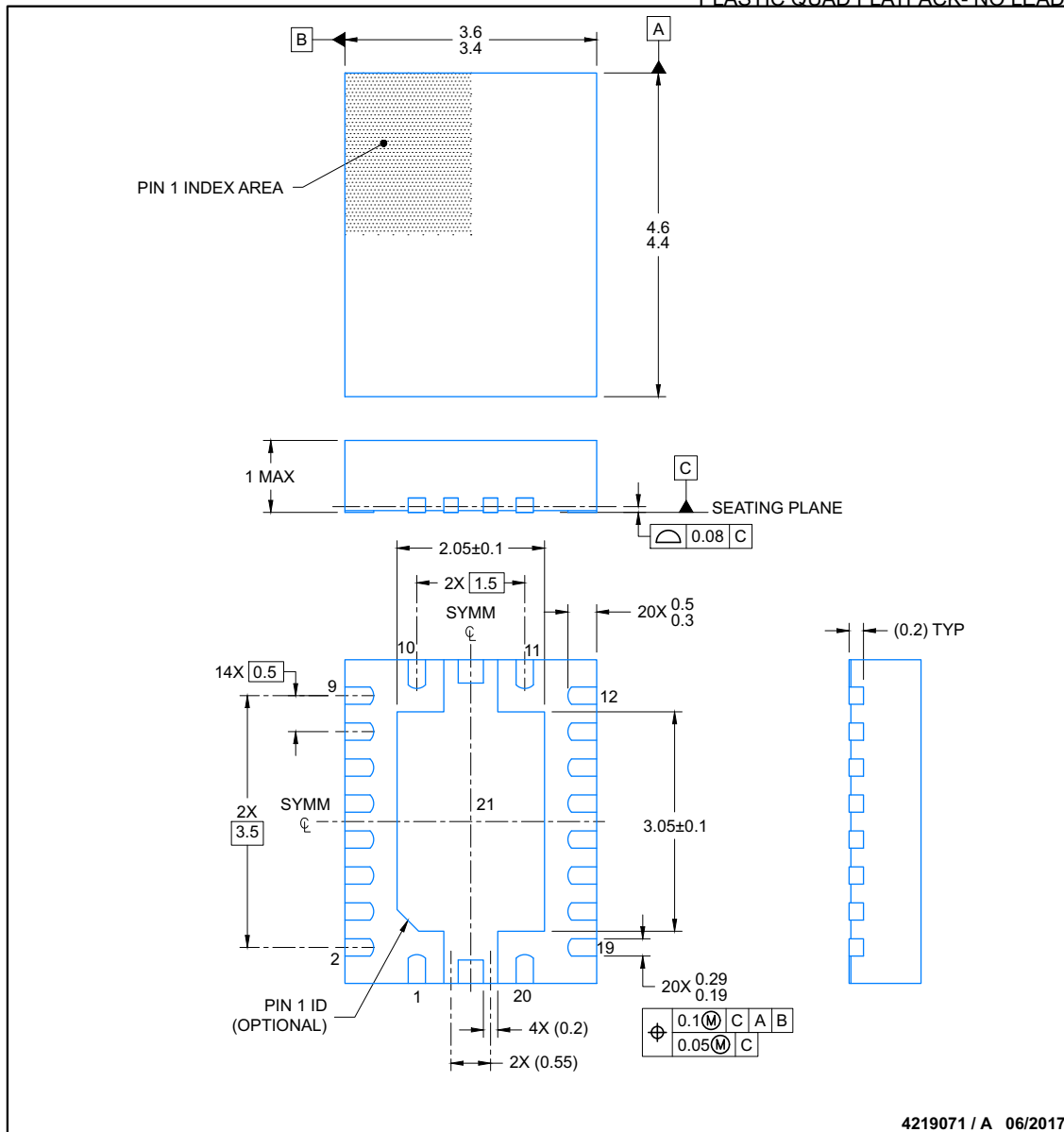

NOTES:

1. All linear dimensions are in millimeters. Any dimensions in parenthesis are for reference only. Dimensioning and tolerancing per ASME Y14.5M.
2. This drawing is subject to change without notice.
3. The package thermal pad must be soldered to the printed circuit board for thermal and mechanical performance.

## EXAMPLE BOARD LAYOUT

RHL0020A

VQFN - 1 mm max height

PLASTIC QUAD FLATPACK- NO LEAD

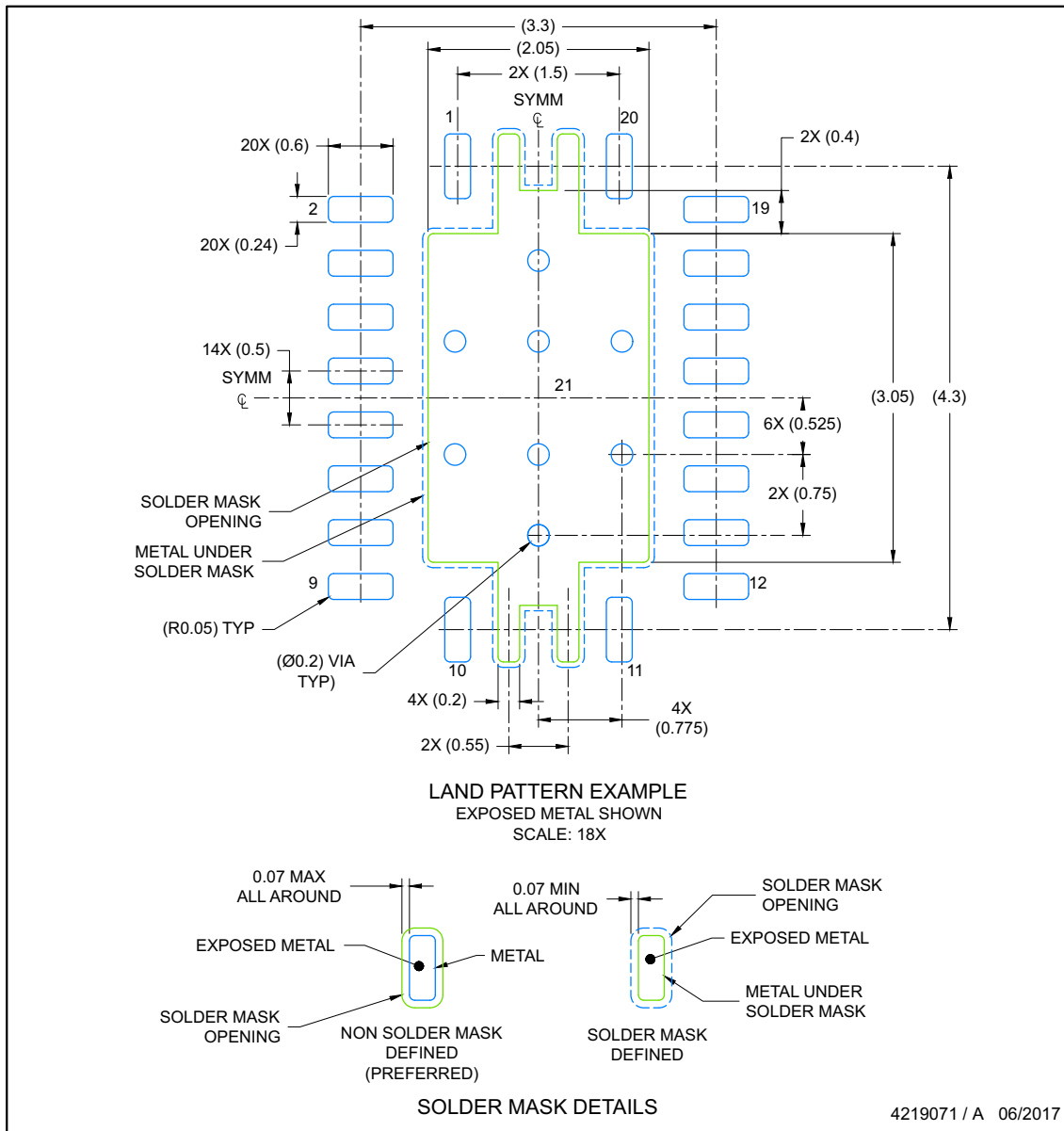

NOTES: (continued)

4. This package is designed to be soldered to a thermal pad on the board. For more information, see Texas Instruments literature number SLUA271 ([www.ti.com/lit/slua271](http://www.ti.com/lit/slua271)).
5. Solder mask tolerances between and around signal pads can vary based on board fabrication site.
6. Vias are optional depending on application, refer to device data sheet. If any vias are implemented, refer to their locations shown on this view. It is recommended that vias under paste be filled, plugged or tented.

www.ti.com

**EXAMPLE STENCIL DESIGN**  
**VQFN - 1 mm max height**

**RHL0020A**

PLASTIC QUAD FLATPACK- NO LEAD

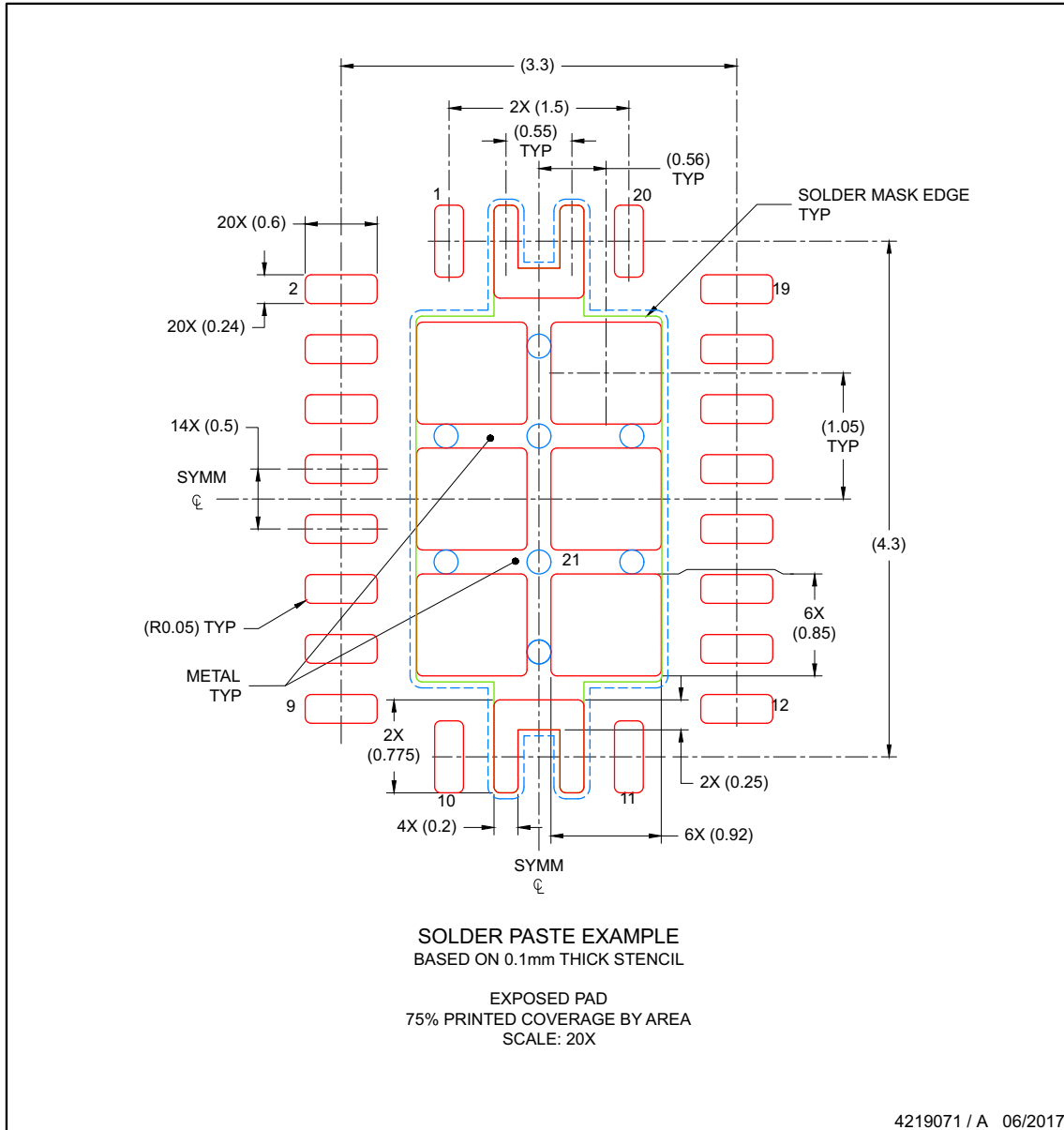

NOTES: (continued)

7. Laser cutting apertures with trapezoidal walls and rounded corners may offer better paste release. IPC-7525 may have alternate design recommendations..

**PACKAGING INFORMATION**

Orderable Device	Status (1)	Package Type	Package Drawing	Pins	Package Qty	Eco Plan (2)	Lead finish/ Ball material (6)	MSL Peak Temp (3)	Op Temp (°C)	Device Marking (4/5)	Samples
MSP430FR2422IPW16	ACTIVE	TSSOP	PW	16	90	RoHS & Green	NIPDAU	Level-2-260C-1 YEAR	-40 to 85	FR2422	<a href="#">Samples</a>
MSP430FR2422IPW16R	ACTIVE	TSSOP	PW	16	2000	RoHS & Green	NIPDAU	Level-2-260C-1 YEAR	-40 to 85	FR2422	<a href="#">Samples</a>
MSP430FR2422IRHLR	ACTIVE	VQFN	RHL	20	3000	RoHS & Green	NIPDAU	Level-2-260C-1 YEAR	-40 to 85	FR2422	<a href="#">Samples</a>
MSP430FR2422IRHLT	ACTIVE	VQFN	RHL	20	250	RoHS & Green	NIPDAU	Level-2-260C-1 YEAR	-40 to 85	FR2422	<a href="#">Samples</a>

(1) The marketing status values are defined as follows:

**ACTIVE:** Product device recommended for new designs.

**LIFEBUY:** TI has announced that the device will be discontinued, and a lifetime-buy period is in effect.

**NRND:** Not recommended for new designs. Device is in production to support existing customers, but TI does not recommend using this part in a new design.

**PREVIEW:** Device has been announced but is not in production. Samples may or may not be available.

**OBSELETE:** TI has discontinued the production of the device.

(2) **RoHS:** TI defines "RoHS" to mean semiconductor products that are compliant with the current EU RoHS requirements for all 10 RoHS substances, including the requirement that RoHS substance do not exceed 0.1% by weight in homogeneous materials. Where designed to be soldered at high temperatures, "RoHS" products are suitable for use in specified lead-free processes. TI may reference these types of products as "Pb-Free".

**RoHS Exempt:** TI defines "RoHS Exempt" to mean products that contain lead but are compliant with EU RoHS pursuant to a specific EU RoHS exemption.

**Green:** TI defines "Green" to mean the content of Chlorine (Cl) and Bromine (Br) based flame retardants meet JS709B low halogen requirements of <=1000ppm threshold. Antimony trioxide based flame retardants must also meet the <=1000ppm threshold requirement.

(3) MSL, Peak Temp. - The Moisture Sensitivity Level rating according to the JEDEC industry standard classifications, and peak solder temperature.

(4) There may be additional marking, which relates to the logo, the lot trace code information, or the environmental category on the device.

(5) Multiple Device Markings will be inside parentheses. Only one Device Marking contained in parentheses and separated by a "-" will appear on a device. If a line is indented then it is a continuation of the previous line and the two combined represent the entire Device Marking for that device.

(6) Lead finish/Ball material - Orderable Devices may have multiple material finish options. Finish options are separated by a vertical ruled line. Lead finish/Ball material values may wrap to two lines if the finish value exceeds the maximum column width.

**Important Information and Disclaimer:**The information provided on this page represents TI's knowledge and belief as of the date that it is provided. TI bases its knowledge and belief on information provided by third parties, and makes no representation or warranty as to the accuracy of such information. Efforts are underway to better integrate information from third parties. TI has taken and

continues to take reasonable steps to provide representative and accurate information but may not have conducted destructive testing or chemical analysis on incoming materials and chemicals. TI and TI suppliers consider certain information to be proprietary, and thus CAS numbers and other limited information may not be available for release.

In no event shall TI's liability arising out of such information exceed the total purchase price of the TI part(s) at issue in this document sold by TI to Customer on an annual basis.

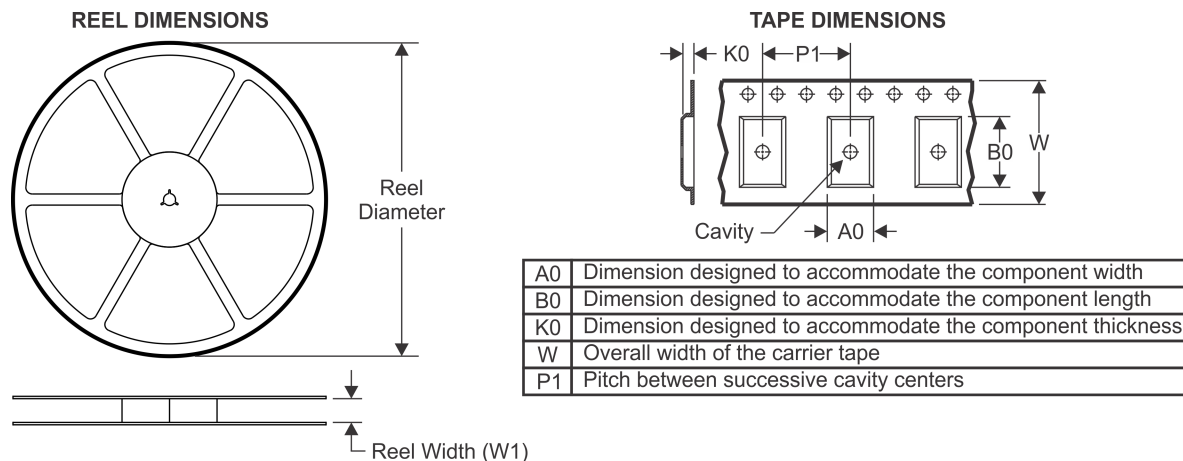
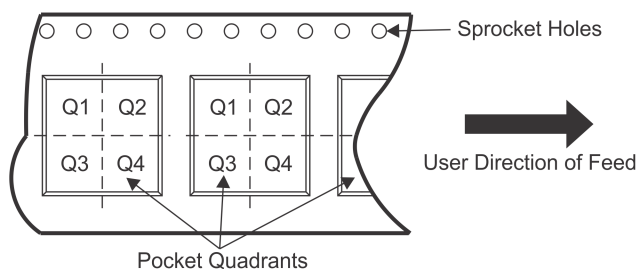
**TAPE AND REEL INFORMATION**

**QUADRANT ASSIGNMENTS FOR PIN 1 ORIENTATION IN TAPE**

\*All dimensions are nominal

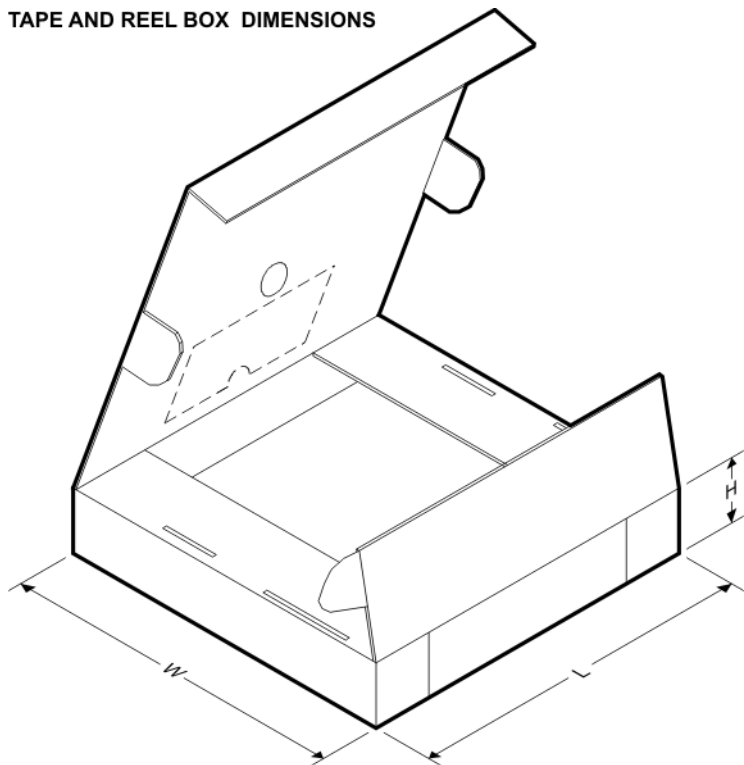
Device	Package Type	Package Drawing	Pins	SPQ	Reel Diameter (mm)	Reel Width W1 (mm)	A0 (mm)	B0 (mm)	K0 (mm)	P1 (mm)	W (mm)	Pin1 Quadrant
MSP430FR2422IPW16R	TSSOP	PW	16	2000	330.0	12.4	6.9	5.6	1.6	8.0	12.0	Q1
MSP430FR2422IRHLR	VQFN	RHL	20	3000	330.0	12.4	3.71	4.71	1.1	8.0	12.0	Q1
MSP430FR2422IRHLT	VQFN	RHL	20	250	180.0	12.4	3.71	4.71	1.1	8.0	12.0	Q1

**TAPE AND REEL BOX DIMENSIONS**

\*All dimensions are nominal

Device	Package Type	Package Drawing	Pins	SPQ	Length (mm)	Width (mm)	Height (mm)
MSP430FR2422IPW16R	TSSOP	PW	16	2000	367.0	367.0	35.0
MSP430FR2422IRHLR	VQFN	RHL	20	3000	367.0	367.0	35.0
MSP430FR2422IRHLT	VQFN	RHL	20	250	210.0	185.0	35.0

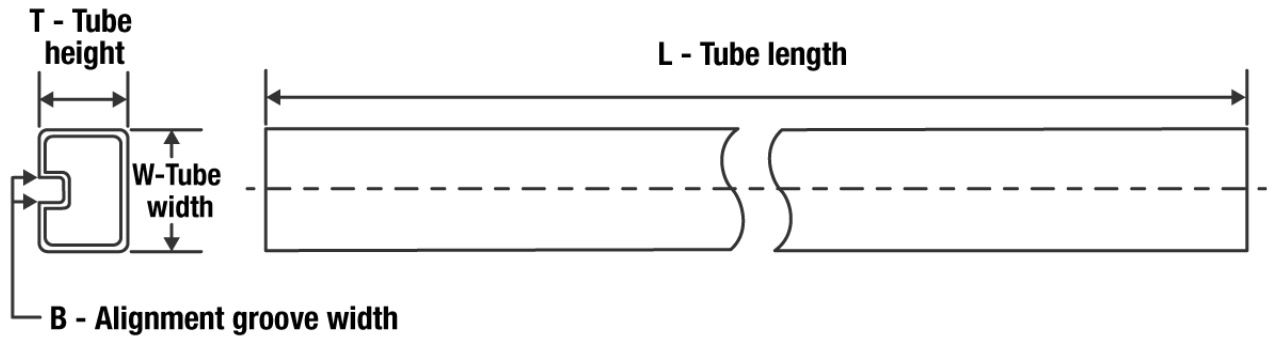
**TUBE**

\*All dimensions are nominal

Device	Package Name	Package Type	Pins	SPQ	L (mm)	W (mm)	T (μm)	B (mm)
MSP430FR2422IPW16	PW	TSSOP	16	90	530	10.2	3600	3.5

## 重要声明和免责声明

TI“按原样”提供技术和可靠性数据（包括数据表）、设计资源（包括参考设计）、应用或其他设计建议、网络工具、安全信息和其他资源，不保证没有瑕疵且不做任何明示或暗示的担保，包括但不限于对适销性、某特定用途方面的适用性或不侵犯任何第三方知识产权的暗示担保。

这些资源可供使用 TI 产品进行设计的熟练开发人员使用。您将自行承担以下全部责任：(1) 针对您的应用选择合适的 TI 产品，(2) 设计、验证并测试您的应用，(3) 确保您的应用满足相应标准以及任何其他功能安全、信息安全、监管或其他要求。

这些资源如有变更，恕不另行通知。TI 授权您仅可将这些资源用于研发本资源所述的 TI 产品的应用。严禁对这些资源进行其他复制或展示。您无权使用任何其他 TI 知识产权或任何第三方知识产权。您应全额赔偿因在这些资源的使用中对 TI 及其代表造成的任何索赔、损害、成本、损失和债务，TI 对此概不负责。

TI 提供的产品受 [TI 的销售条款](#) 或 [ti.com](#) 上其他适用条款/TI 产品随附的其他适用条款的约束。TI 提供这些资源并不会扩展或以其他方式更改 TI 针对 TI 产品发布的适用的担保或担保免责声明。

TI 反对并拒绝您可能提出的任何其他或不同的条款。

邮寄地址：Texas Instruments, Post Office Box 655303, Dallas, Texas 75265

Copyright © 2022，德州仪器 (TI) 公司