

TPS1H100-Q1 40V、100mΩ 单通道智能高侧电源开关

1 特性

- 符合汽车类 应用要求
- 具有符合 AEC-Q100 标准的下列特性：
 - 器件温度等级 1: -40°C 至 125°C 的环境工作温度范围
 - 器件 HBM ESD 分类等级 H3A
 - 器件 CDM ESD 分类等级 C4B
- 提供功能安全
 - 提供文档以帮助创建功能安全系统设计
- 具有全面诊断功能的单通道智能高侧电源开关
 - 版本 A: 开漏状态输出
 - 版本 B: 电流感应模拟输出
- 宽工作电压范围: 3.5V 至 40V
- 超低待机电流, 低于 $0.5\mu\text{A}$
- 工作结温范围, -40°C 至 150°C
- 输入控制, 兼容 3.3V 和 5V 逻辑
- 高精度电流感应, 电流为 1A 时为 $\pm 30\text{mA}$, 电流为 5mA 时为 $\pm 4\text{mA}$
- 利用外部电阻器实现可编程电流限制 (在 0.5A 时为 $\pm 20\%$)
- 用于对 MCU 模拟或数字接口进行多路复用的诊断使能功能
- 测试符合 AECQ100-12 A 级标准, 经过 100 万次接地短路测试
- 通过 ISO7637-2 和 ISO16750-2 电瞬变抗扰度认证
- 保护
 - 过载和短路保护
 - 电感负载负电压钳位

- 欠压锁定 (UVLO) 保护
- 具备自恢复功能的热关断/热振荡
- 接地失效保护和失电保护
- 对外部电路提供反向电池保护
- 诊断
 - 开启和关闭状态输出的开路 and 电池短路检测
 - 过载和接地短路检测以及电流限制
 - 热关断/热振荡检测
- 14 引脚热增强型 PWP 封装

2 应用

- 适用于子模块的高侧电源开关
- 适用于低功率灯的电源开关
- 高侧继电器和电磁阀
- PLC 数字输出电源开关
- 一般阻性、感性和容性负载

3 说明

TPS1H100-Q1 是一款具有全方位保护的高侧电源开关, 它集成有 NMOS 功率 FET 和电荷泵, 专用于对各类阻性、感性和容性负载进行智能控制。精确的电流检测和可编程电流限制 特性 使该器件从市场中脱颖而出。

器件信息(1)

器件型号	封装	封装尺寸 (标称值)
TPS1H100-Q1	HTSSOP (14)	4.40mm x 5.00mm

(1) 如需了解所有可用封装, 请参阅产品说明书末尾的可订购产品附录。

典型应用原理图

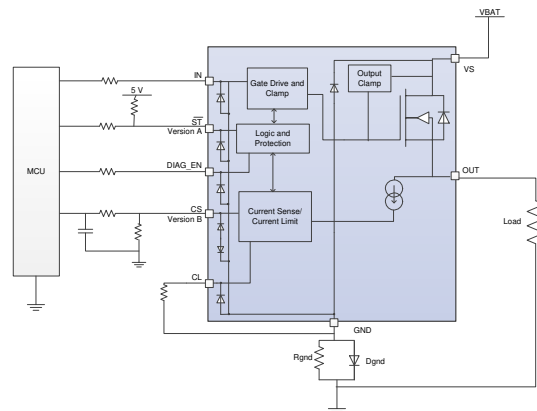

目录

1	特性	1	7.3	Feature Description	16
2	应用	1	7.4	Device Functional Modes	31
3	说明	1	8	Application and Implementation	32
4	修订历史记录	2	8.1	Application Information	32
5	Pin Configuration and Functions	3	8.2	Typical Application	32
6	Specifications	4	9	Power Supply Recommendations	37
6.1	Absolute Maximum Ratings	4	10	Layout	37
6.2	ESD Ratings	4	10.1	Layout Guidelines	37
6.3	Recommended Operating Conditions	4	10.2	Layout Example	37
6.4	Thermal Information	5	10.3	Thermal Considerations	38
6.5	Electrical Characteristics	6	11	器件和文档支持	39
6.6	Timing Requirements – Current Sense Characteristics	8	11.1	接收文档更新通知	39
6.7	Switching Characteristics	9	11.2	社区资源	39
6.8	Typical Characteristics	11	11.3	商标	39
7	Detailed Description	15	11.4	静电放电警告	39
7.1	Overview	15	11.5	Glossary	39
7.2	Functional Block Diagram	16	12	机械、封装和可订购信息	39

4 修订历史记录

注：之前版本的页码可能与当前版本有所不同。

Changes from Revision C (June 2018) to Revision D	Page
• 向 特性 部分添加了提供功能安全的链接	1

Changes from Revision B (June 2015) to Revision C	Page
• Changed the <i>Pin Functions</i> table to alphabetical order and created separate columns for the Version A and Version B devices	3
• Added tablenotes to the <i>Electrical Characteristics</i> table	7
• 添加了 接收文档更新通知 部分	39

Changes from Revision A (January 2015) to Revision B	Page
• Updated Figure 6 and Figure 7	10
• Updated Figure 38	25
• Updated Figure 39	26
• Updated Figure 40	27
• 添加了 社区资源	39

Changes from Original (October 2014) to Revision A	Page
• 将器件状态从预览更新为生产数据	1

5 Pin Configuration and Functions

**PWP Package Version A
14-Pin HTSSOP
Top View**

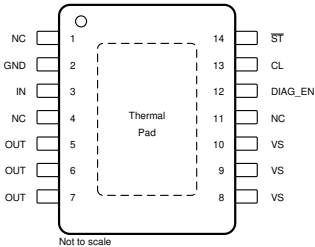

**PWP Package Version B
14-Pin HTSSOP
Top View**

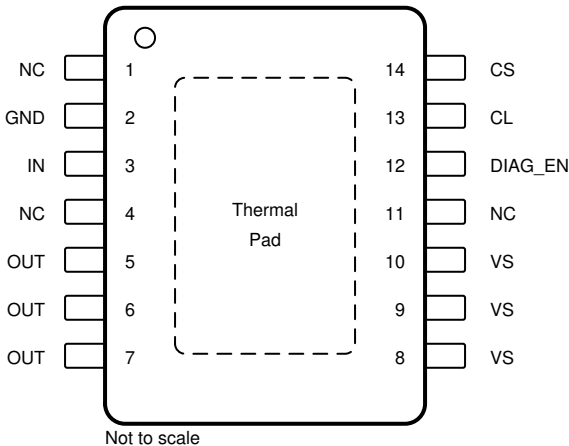

Pin Functions

NAME	PIN		I/O	DESCRIPTION
	VER. A	VER. B		
CL	13	13	O	Programmable current-limit pin. Connect to device GND if external current limit is not used.
CS	—	14	O	Current-sense output. Leave floating if not used.
DIAG_EN	12	12	I	Enable and disable pin for diagnostic functions. Connect to device GND if not used.
GND	2	2	—	Ground pin
IN	3	3	I	Input control for channel activation
NC	1, 4, 11	1, 4, 11	—	No-connect pin; leave floating.
OUT	5, 6, 7	5, 6, 7	O	Output, connected to load (NMOS source)
\overline{ST}	14	—	O	Open-drain diagnostic status output. Leave floating if not used.
VS	8, 9, 10	8, 9, 10	I	Power supply; battery voltage
Thermal pad	—	—	—	Thermal pad. Connect to device GND or leave floating.

6 Specifications

6.1 Absolute Maximum Ratings

 over operating free-air temperature range (unless otherwise noted) ⁽¹⁾⁽²⁾⁽³⁾

	MIN	MAX	UNIT
Supply voltage ⁽⁴⁾ , $t < 400$ ms		48	V
Reverse polarity voltage ⁽⁵⁾	-18		V
Continuous drain current	Internally limited		A
Reverse current on GND	-50	20	mA
Reverse current on GND, $t < 120$ s	-250	20	mA
Voltage on IN/DIAG_EN pin	-0.3	7	V
Current on IN /DIAG_EN pin	-30	2	mA
Voltage on \overline{ST} pin	-0.3	7	V
Current on \overline{ST} pin	-30	10	mA
IN pin PWM frequency		2	KHz
Voltage on CL pin	-0.3	7	V
Current on CL pin	-2	30	mA
Voltage on CS pin	-2.7	6.5	V
Current on CS pin	-2	30	mA
Inductive load switch-off energy dissipation, single pulse ⁽⁶⁾		70	mJ
Operating ambient temperature	-40	125	°C
Operating junction temperature	-40	150	°C
Storage temperature, T_{stg}	-65	150	°C

- (1) Stresses beyond those listed under *Absolute Maximum Ratings* may cause permanent damage to the device. These are stress ratings only, which do not imply functional operation of the device at these or any other conditions beyond those indicated under *Recommended Operating Conditions*. Exposure to absolute-maximum-rated conditions for extended periods may affect device reliability.
- (2) All voltage values are with respect to GND.
- (3) Absolute negative voltage on these terminals is not to go below -0.3 V.
- (4) Absolute maximum voltage, withstand 48-V load dump voltage for 400 ms.
- (5) Reverse polarity condition: $t < 60$ s, reverse current $< I_{rev1}$, GND pin 1-k Ω resistor in parallel with diode.
- (6) Test condition: $V_S = 13.5$ V, $L = 8$ mH, $R = 0$ Ω , $T_J = 150$ °C. FR4 2s2p board, 2- x 70- μ m Cu, 2- x 35- μ m Cu. 600-mm² thermal pad copper area.

6.2 ESD Ratings

			VALUE	UNIT
$V_{(ESD)}$	Electrostatic discharge	Human body model (HBM) AEC-Q100 Classification Level H3A ⁽¹⁾	VS, OUT, GND	± 5000
		Human body model (HBM) AEC-Q100 Classification Level H2 ⁽¹⁾	Other pins	± 4000
		Charged device model (CDM), per AEC Q100-011 ⁽²⁾		± 750

- (1) The human-body model is a 107-pF capacitor discharged through a 1.5-k Ω resistor into each terminal.
- (2) The charged-device model is tested according to AEC_Q100-011C.

6.3 Recommended Operating Conditions

over operating free-air temperature range (unless otherwise noted)

		MIN	MAX	UNIT
V_S	Operating voltage	5	40	V
	Voltage on IN/DIAG_EN pin	0	5	V
	Voltage on \overline{ST} pin	0	5	V
$I_{o,nom}$	Nominal DC load current	0	4	A
T_J	Operating junction temperature range	-40	150	°C

6.4 Thermal Information

THERMAL METRIC ⁽¹⁾		TPS1H100-Q1	UNIT
		PWP (HTSSOP)	
		14 PINS	
$R_{\theta JA}$	Junction-to-ambient thermal resistance ⁽²⁾	41	°C/W
$R_{\theta JC(top)}$	Junction-to-case (top) thermal resistance	29.7	°C/W
$R_{\theta JB}$	Junction-to-board thermal resistance	25.1	°C/W
Ψ_{JT}	Junction-to-top characterization parameter	0.9	°C/W
Ψ_{JB}	Junction-to-board characterization parameter	24.8	°C/W
$R_{\theta JC(bot)}$	Junction-to-case (bottom) thermal resistance	2.7	°C/W

- (1) For more information about traditional and new thermal metrics, see the [Semiconductor and IC Package Thermal Metrics](#) application report.
- (2) The thermal data is based on JEDEC standard high-K profile – JESD 51-7. The copper pad is soldered to the thermal land pattern. Also, correct attachment procedure must be incorporated.

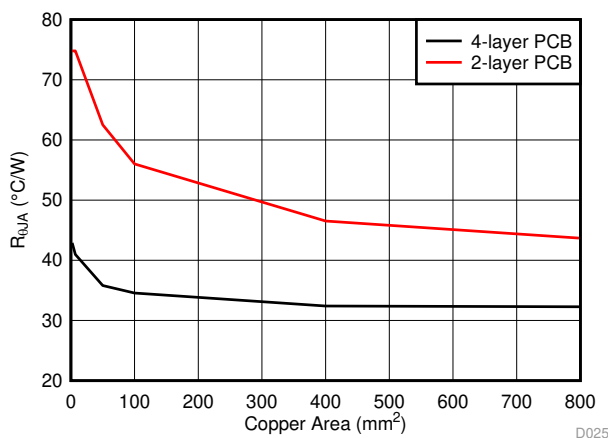

- (1) 4-layer board: FR4 2s2p board, 2.8-mil copper (top/bottom), 1.4-mil copper (internal layers). 76.4- x 114.3- x 1.5-mm board size.
- (2) 2-layer board: FR4 2s0p board, 2.8-mil copper (top/bottom). 76.4- x 114.3- x 1.5-mm board size.

Figure 1. R_{θJA} Value vs Copper Area

6.5 Electrical Characteristics

5 V < V_S < 40 V; –40°C < T_J < 150°C unless otherwise specified

PARAMETER		TEST CONDITIONS	MIN	TYP	MAX	UNIT
OPERATING VOLTAGE						
V _{S,nom}	Nominal operating voltage		5		40	V
V _{S,op}	Extended operating voltage	R _{DS(on)} value increases maximum 20%, compared to 5 V, see R _{DS(on)} parameter	3.5		5	V
V _{S,UVR}	Undervoltage restart	V _S rises up, V _S > V _{S,UVR} , device turn on	3.5	3.7	4	V
V _{S,UVF}	Undervoltage shutdown	V _S falls down, V _S < V _{S,UVF} , device shuts off	3	3.2	3.5	V
V _{UV,hys}	Undervoltage shutdown, hysteresis			0.5		V
OPERATING CURRENT						
I _{nom}	Nominal operating current	V _{IN} = 5 V, V _{DIAG_EN} = 0 V, no load			5	mA
		V _{IN} = 5 V, V _{DIAG_EN} = 0 V, 10-Ω load			10	mA
I _{off}	Standby current	V _S = 13.5 V, V _{IN} = V _{DIAG_EN} = V _{CS} = V _{CL} = V _{OUTPUT} = 0 V, T _J = 25°C			0.5	μA
		V _S = 13.5 V, V _{IN} = V _{DIAG_EN} = V _{CS} = V _{CL} = V _{OUTPUT} = 0 V, T _J = 125°C			5	μA
I _{off,diag}	Standby current with diagnostic enabled	V _{IN} = 0 V, V _{DIAG_EN} = 5 V			1.2	mA
t _{off,deg}	Standby mode deglitch time ⁽¹⁾	IN from high to low, if deglitch time > t _{off,deg} , enters into standby mode.		2		ms
I _{leak,out}	Off-state output leakage current	V _S = 13.5 V, V _{IN} = V _{OUTPUT} = 0, T _J = 25°C			0.5	μA
		V _S = 13.5 V, V _{IN} = V _{OUTPUT} = 0, T _J = 125°C			3	μA
POWER STAGE						
R _{DS-ON}	On-state resistance	V _S > 5 V, T _J = 25°C		80	100	mΩ
		V _S > 5 V, T _J = 150°C			166	mΩ
		V _S = 3.5 V, T _J = 25°C			120	mΩ
I _{lim,nom}	Internal current limit		7		13	A
I _{lim,tsd}	Current limit during thermal shutdown	Internal current limit, thermal cycling condition		5		A
		External current limit, thermal cycling condition; Percentage of current limit set value		50%		
V _{DS}	Clamp drain-to-source voltage internally clamped		50		70	V
OUTPUT DIODE CHARACTERISTICS						
V _F	Drain-to-source diode voltage	V _{IN} = 0, I _{OUT} = –0.2 A		0.7		V
I _{rev1}	Continuous reverse current when reverse polarity ⁽²⁾	t < 60 s, V _S = 13.5 V, GND pin 1-kΩ resistor in parallel with diode. T _J = 25°C. See I _{rev1} test condition (Figure 6).		4		A
I _{rev2}	Continuous reverse current when V _{OUT} > V _S + V _{diode} ⁽²⁾	t < 60 s, V _S = 13.5 V. T _J = 25°C. See I _{rev2} test condition (Figure 7).		2		A
LOGIC INPUT (IN AND DIAG_EN)						
V _{logic,h}	Input or DIAG_EN high-level voltage		2			V
V _{logic,l}	Input or DIAG_EN low-level voltage				0.8	V
V _{logic,hys}	Input or DIAG_EN hysteresis voltage			250		mV
R _{pd,in}	Input pulldown resistor			500		kΩ
R _{pd,diag}	Diag pulldown resistor			150		kΩ

(1) Value is specified by design, not subject to production test.

(2) Value is based on the minimum value of the 10 pcs/3 lots samples.

Electrical Characteristics (continued)

5 V < V_S < 40 V; –40°C < T_J < 150°C unless otherwise specified

PARAMETER		TEST CONDITIONS	MIN	TYP	MAX	UNIT
DIAGNOSTICS						
I _{loss,gnd}	Loss-of-ground output leakage current				100	μA
V _{ol,off}	Open-load detection threshold in off-state	V _{IN} = 0 V, When V _S – V _{OUT} < V _{ol,off} , duration longer than t _{ol,off} . Open load detected.	1.4	1.8	2.6	V
I _{ol,off}	Off-state output sink current with open load	V _{IN} = 0 V, V _S = V _{OUT} = 13.5 V, T _J = 125°C.			–50	μA
t _{ol,off}	Open-load detection-threshold deglitch time in off state	V _{IN} = 0 V, When V _S – V _{OUT} < V _{ol,off} , duration longer than t _{ol,off} . Open load detected.		600		μs
I _{ol,on}	Open-load detection threshold in on state	V _{IN} = 5 V, when I _{OUT} < I _{ol,on} , duration longer than t _{ol,on} . Open load detected. Version A only	2	6	10	mA
t _{ol,on}	Open-load detection-threshold deglitch time in on-state	V _{IN} = 5 V, when I _{OUT} < I _{ol,on} , duration longer than t _{ol,on} . Open load detected. Version A only		700		μs
V _{ST}	Status low output voltage	I _{ST} = 2 mA Version A only			0.4	V
T _{SD}	Thermal shutdown threshold			175		°C
T _{SD,rst}	Thermal shutdown status reset			155		
T _{sw}	Thermal swing shutdown threshold			60		
T _{hys}	Hysteresis for resetting the thermal shutdown and swing			10		
CURRENT SENSE (VERSION B) AND CURRENT LIMIT						
K	Current sense current ratio			500		
K _{CL}	Current limit current ratio			2000		
dK/K	Current-sense accuracy	I _{load} ≥ 5 mA	–80		80	%
		I _{load} ≥ 25 mA	–10		10	
		I _{load} ≥ 50 mA	–7		7	
		I _{load} ≥ 0.1 A	–5		5	
		I _{load} ≥ 1 A	–3		3	
dK _{CL} /K _{CL}	External current-limit accuracy ⁽³⁾⁽⁴⁾	I _{limit} ≥ 0.5 A	–20		20	%
		I _{limit} ≥ 1.6 A	–14		14	
V _{CS,lin}	Linear current sense voltage range ⁽¹⁾	V _S ≥ 5 V	0		4	V
I _{OUT,lin}	Linear output current range ⁽¹⁾	V _S ≥ 5 V, V _{CS,lin} ≤ 4 V	0		4	A
V _{CS,H}	Current-sense fault high voltage	V _S ≥ 7 V	4.3	4.75	4.9	V
		V _S ≥ 5 V	Min(V _S – 0.8, 4.3)		4.9	
I _{CS,H}	Current sense fault condition current	V _{CS} = 4.3 V, V _S > 7 V	10			mA
V _{CL,th}	Current limit internal threshold voltage ⁽¹⁾			1.233		V
I _{CS,leak}	Current sense leakage current in disabled mode	V _{IN} = 5 V, R _{load} = 10 Ω, V _{DIAG_EN} = 0 V, T _J = 125°C			1	μA
		V _{IN} = 0 V, V _{DIAG_EN} = 0 V, T _J = 125°C			1	μA

(3) External current-limit accuracy is only applicable to overload conditions greater than 1.5x the current-limit setting.

(4) External current-limit setting is recommended to be higher than 500 mA.

6.6 Timing Requirements – Current Sense Characteristics⁽¹⁾

			MIN	NOM	MAX	UNIT
$t_{CS,off1}$	CS settling time from DIAG disabled	$V_{IN} = 5\text{ V}$, $I_{load} \geq 5\text{ mA}$. V_{DIAG_EN} from 5 to 0 V. CS to 10% of sense value.			10	μs
$t_{CS,on1}$	CS settling time from DIAG enabled	$V_{IN} = 5\text{ V}$, $I_{load} \geq 5\text{ mA}$. V_{DIAG_EN} from 0 to 5 V. CS to 90% of sense value.			10	μs
$t_{CS,off2}$	CS settling time from IN falling edge	$V_{DIAG_EN} = 5\text{ V}$, $I_{load} \geq 5\text{ mA}$. IN from 5 to 0 V. CS to 10% of sense value.			10	μs
		$V_{DIAG_EN} = 5\text{ V}$, $I_{load} \geq 5\text{ mA}$. IN from 5 to 0 V. Current limit triggered.			180	μs
$t_{CS,on2}$	CS settling time from IN rising edge	$V_{VS} = 13.5\text{ V}$, $V_{DIAG_EN} = 5\text{ V}$, $I_{load} \geq 100\text{ mA}$. V_{IN} from 0 to 5 V. CS to 90% of sense value.			150	μs

(1) Value specified by design, not subject to production test.

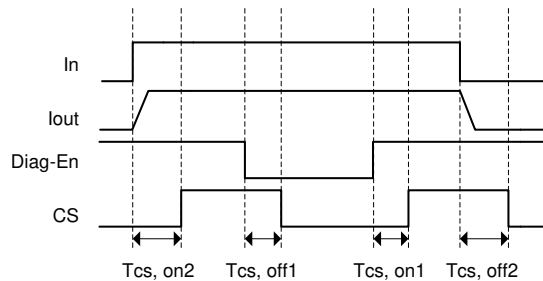

Figure 2. CS Delay Characteristics

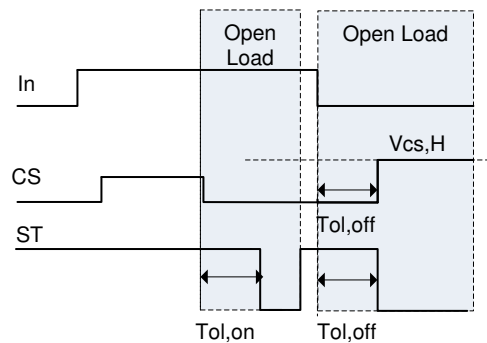

Figure 3. Open-Load Blanking Time Characteristics

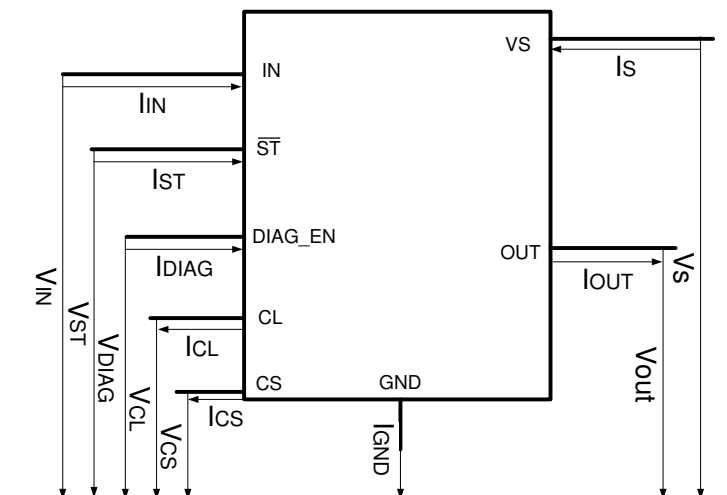

Figure 4. Pin Current and Voltage Conventions

6.7 Switching Characteristics

$V_{VS} = 13.5\text{ V}$, $R_{load} = 10\ \Omega$, over operating free-air temperature range (unless otherwise noted)⁽¹⁾

PARAMETER	TEST CONDITIONS	MIN	TYP	MAX	UNIT
$t_{d,ON}$ Turn-on delay time	IN rising edge to $V_{OUT} = 10\%$, DIAG_EN high	20		50	μs
$t_{d,OFF}$ Turn-off delay time	IN falling edge to $V_{OUT} = 90\%$, DIAG_EN high	20		50	μs
dV/dt_{ON} Slew rate on	$V_{OUT} = 10\%$ to 90% , DIAG_EN high	0.1		0.5	$\text{V}/\mu\text{s}$
dV/dt_{OFF} Slew rate off	$V_{OUT} = 90\%$ to 10% , DIAG_EN high	0.1		0.5	$\text{V}/\mu\text{s}$
Slew rate on and off matching		-0.15		0.15	$\text{V}/\mu\text{s}$

(1) Value specified by design, not subject to production test.

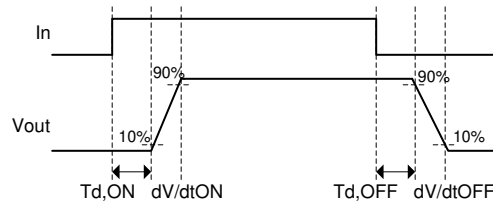

Figure 5. Switching Characteristics Diagram

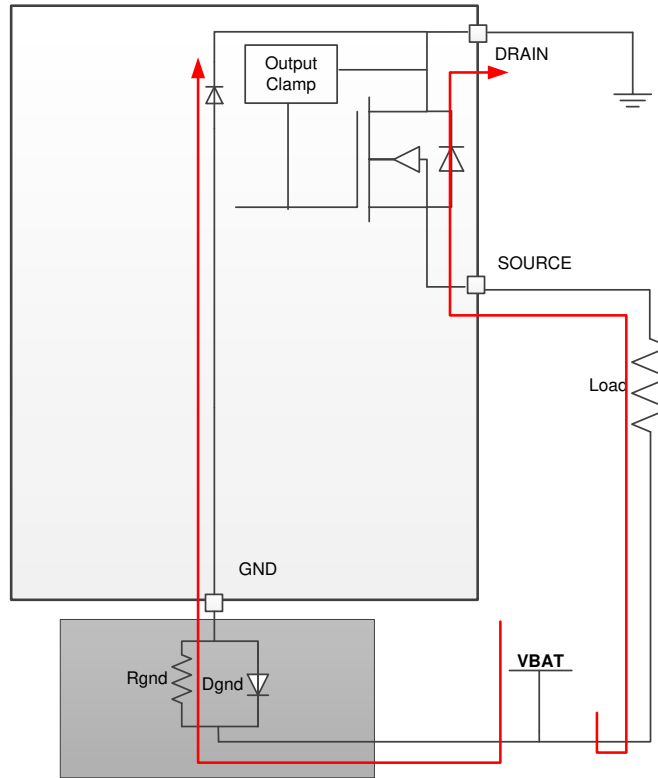

Figure 6. I_{rev1} Test Condition

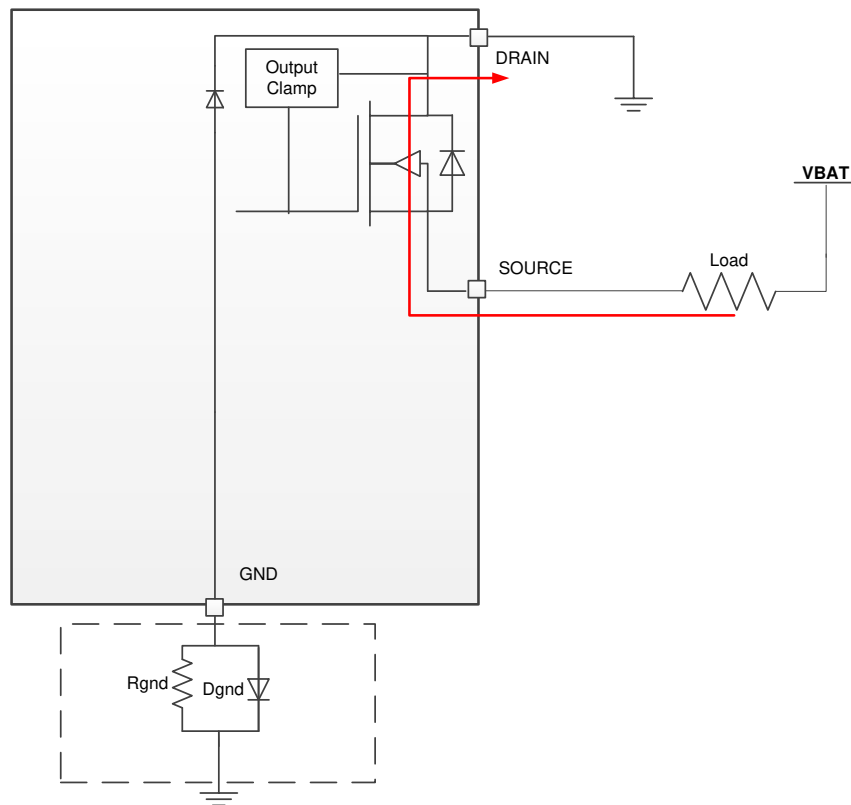

Figure 7. I_{rev2} Test Condition

6.8 Typical Characteristics

All the following data are based on the mean value of the three lots samples, $V_{VS} = 13.5\text{ V}$ if not specified.

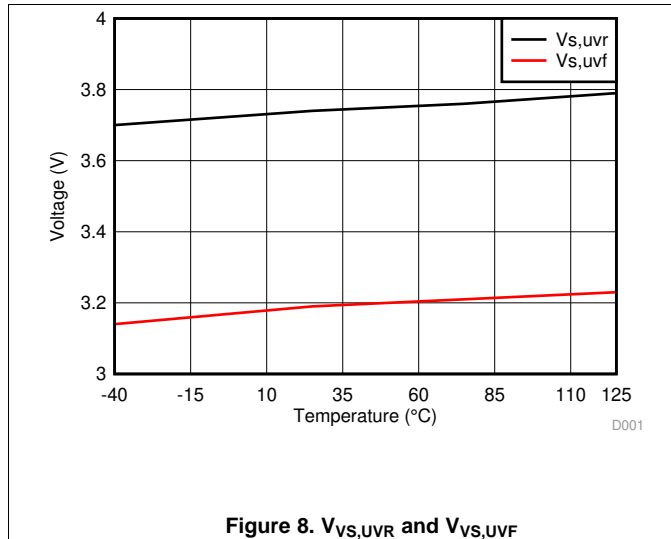

Figure 8. $V_{VS,UVR}$ and $V_{VS,UVF}$

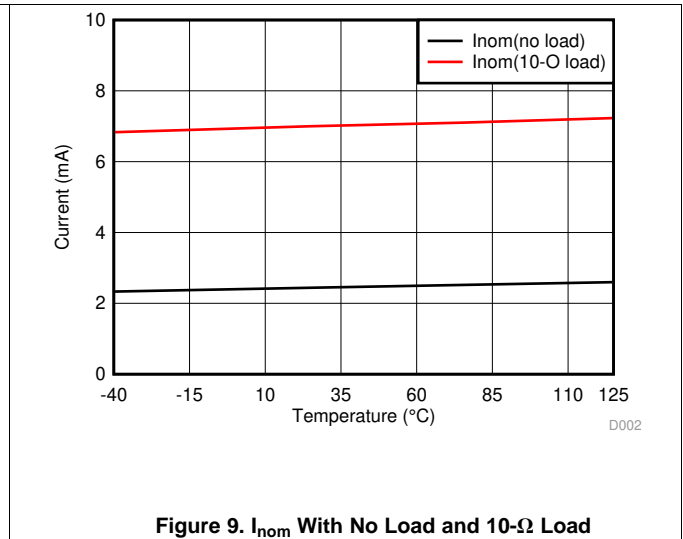

Figure 9. I_{nom} With No Load and 10- Ω Load

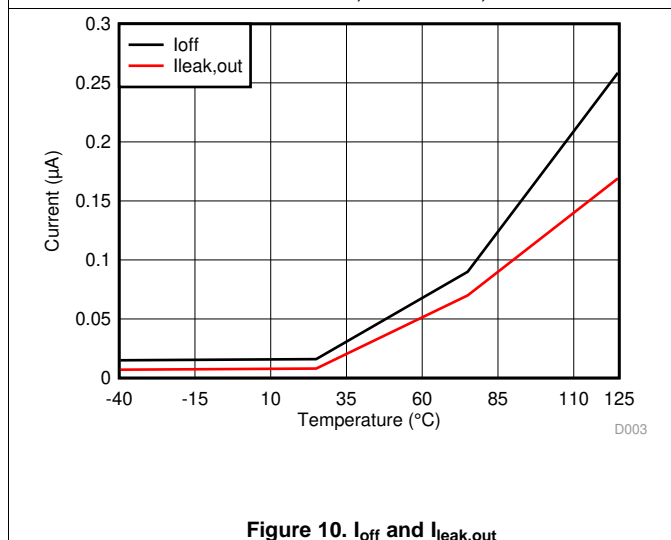

Figure 10. I_{off} and $I_{leak,out}$

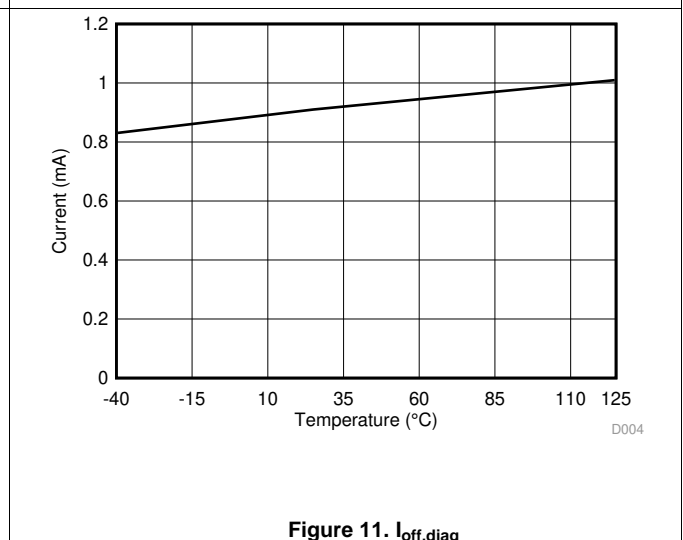

Figure 11. $I_{off,diag}$

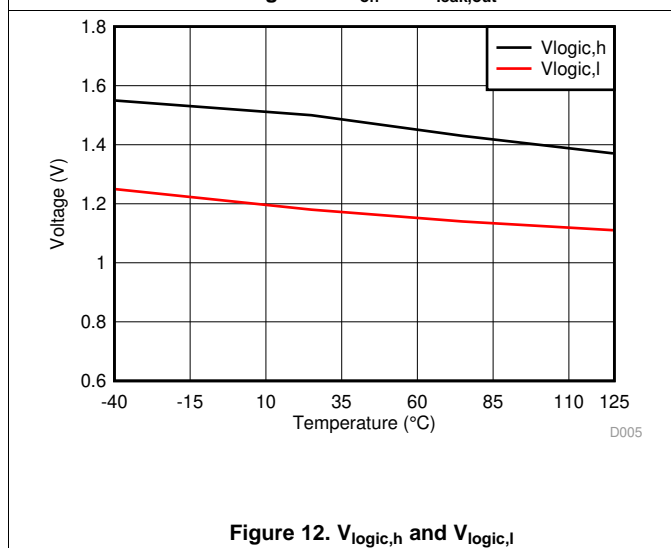

Figure 12. $V_{logic,h}$ and $V_{logic,l}$

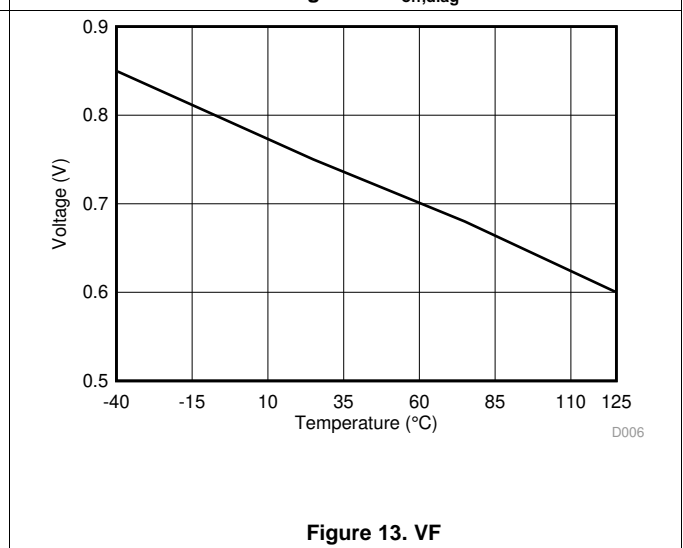

Figure 13. V_F

Typical Characteristics (continued)

All the following data are based on the mean value of the three lots samples, $V_{VS} = 13.5\text{ V}$ if not specified.

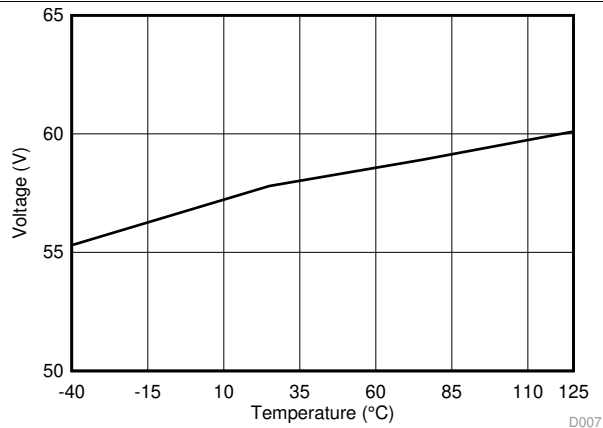

Figure 14. $V_{DS, clamp}$

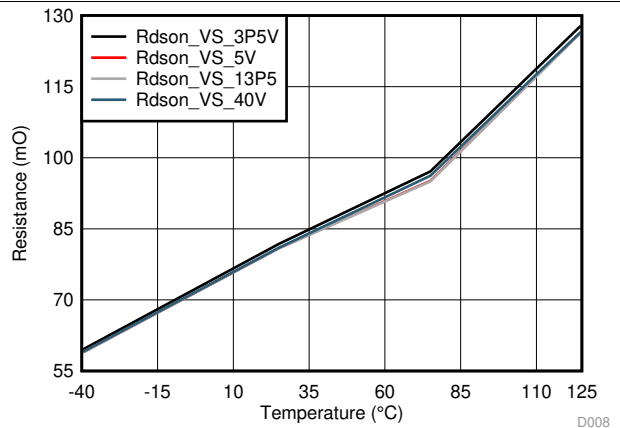

Figure 15. $R_{DS(on)}$

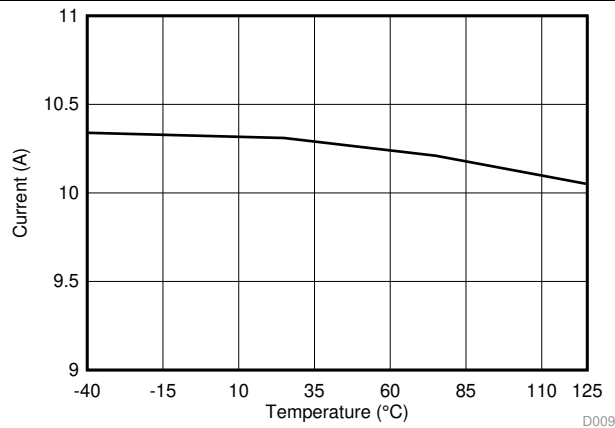

Figure 16. $I_{lim,nom}$

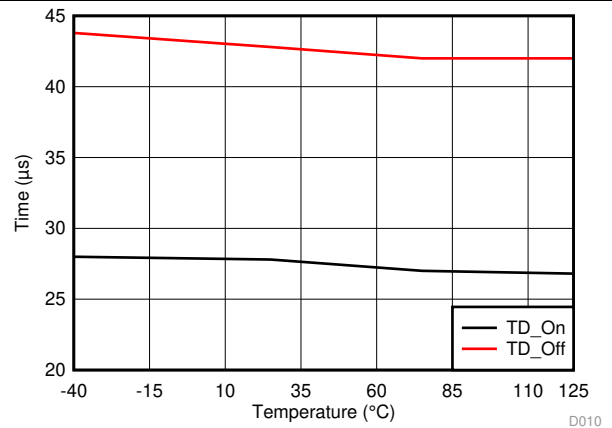

Figure 17. T_{Don} and T_{Doff}

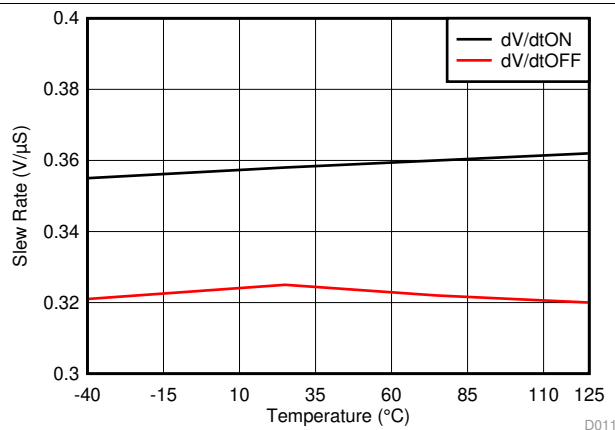

Figure 18. dV/dt_{ON} and dV/dt_{OFF}

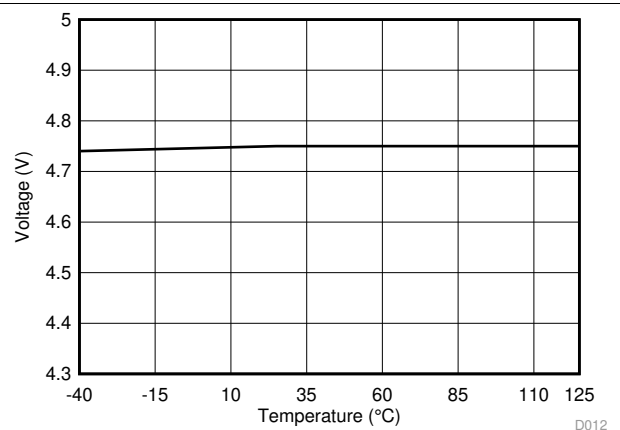

Figure 19. $V_{CS,h}$

Typical Characteristics (continued)

All the following data are based on the mean value of the three lots samples, $V_{VS} = 13.5\text{ V}$ if not specified.

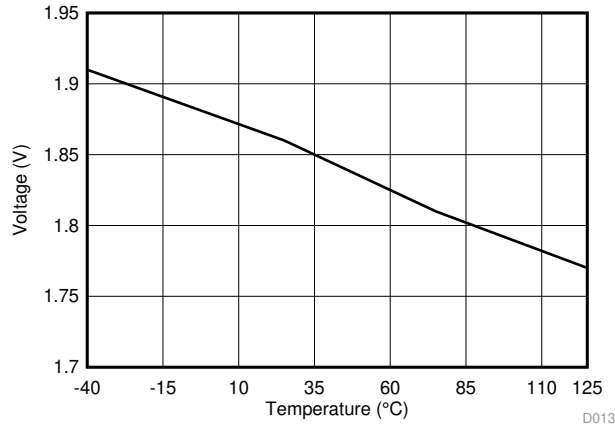

Figure 20. $V_{ol,off}$

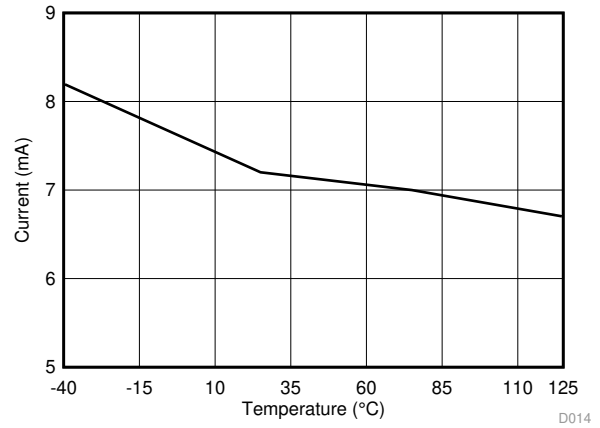

Figure 21. $I_{ol,on}$

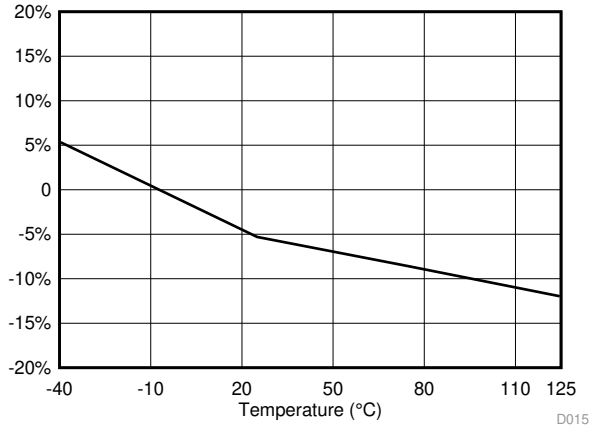

Figure 22. $K_{CS} = 5\text{ mA}, 13.5\text{ V}$

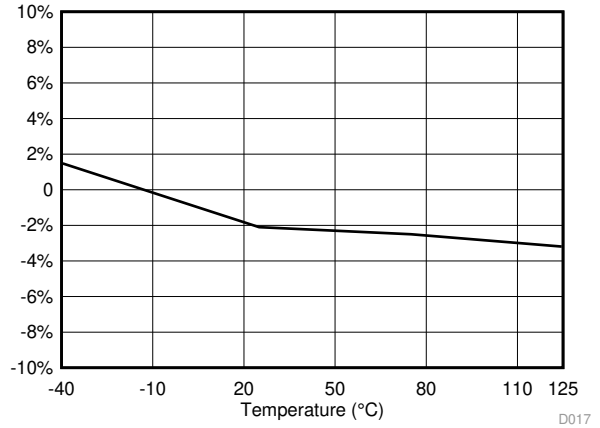

Figure 23. $K_{CS} = 25\text{ mA}, 13.5\text{ V}$

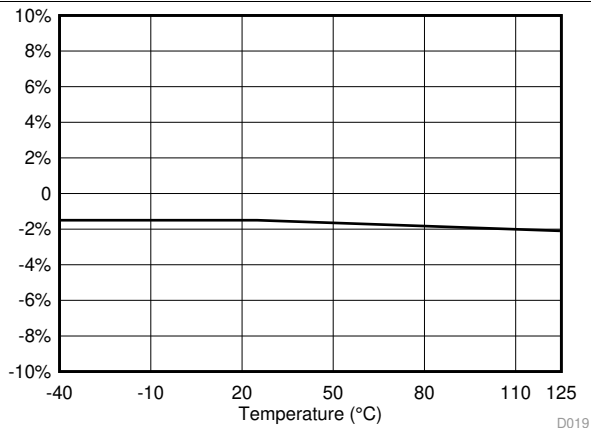

Figure 24. $K_{CS} = 50\text{ mA}, 13.5\text{ V}$

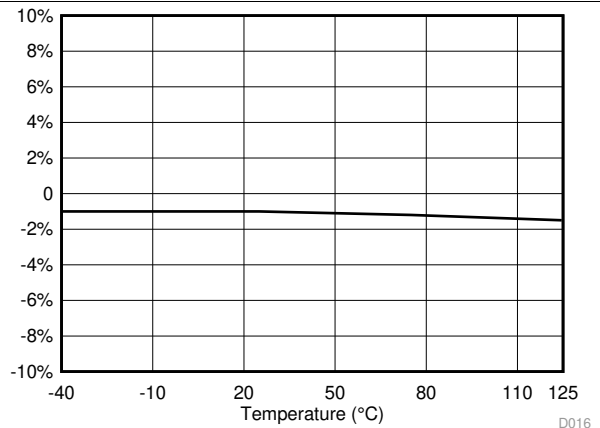

Figure 25. $K_{CS} = 100\text{ mA}, 13.5\text{ V}$

Typical Characteristics (continued)

All the following data are based on the mean value of the three lots samples, $V_{VS} = 13.5\text{ V}$ if not specified.

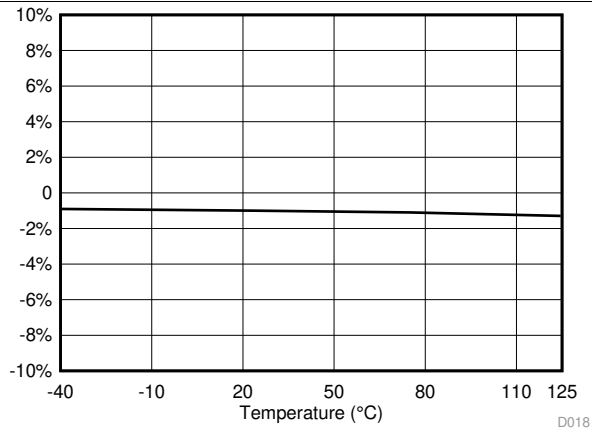

Figure 26. $K_{CS} = 1\text{ A}, 13.5\text{ V}$

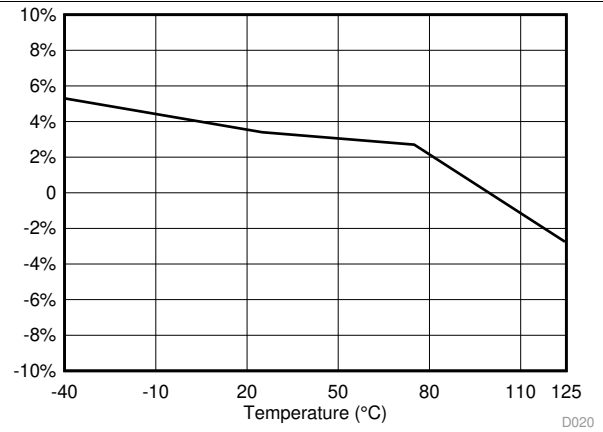

Figure 27. $K_{CL} = 0.5\text{ A}, 13.5\text{ V}$

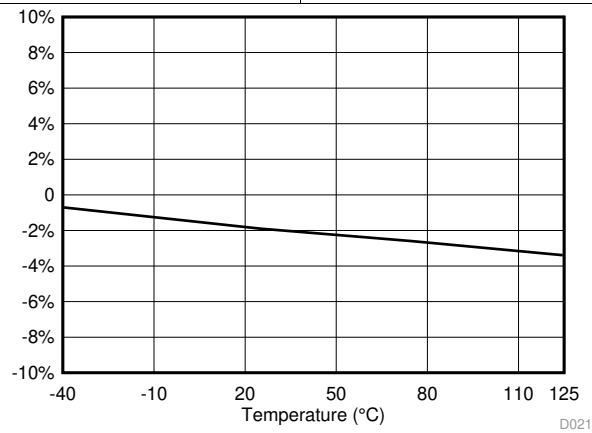

Figure 28. $K_{CL} = 1.6\text{ A}, 13.5\text{ V}$

7 Detailed Description

7.1 Overview

The TPS1H100-Q1 is a single-channel, fully-protected, high-side power switch with an integrated NMOS power FET and charge pump. Full diagnostics and high-accuracy current-sense features enable intelligent control of the load. A programmable current-limit function greatly improves the reliability of the whole system. The device diagnostic reporting has two versions to support both digital status and analog current-sense output, both of which can be set to the high-impedance state when diagnostics are disabled, for multiplexing the MCU analog or digital interface among devices.

For version A, the digital status report is implemented with an open-drain structure. When a fault condition occurs, it pulls down to GND. A 3.3- or 5-V external pullup is required to match the microcontroller supply level. For version B, high-accuracy current sensing allows a better real-time monitoring effect and more-accurate diagnostics without further calibration. A current mirror is used to source $1 / K$ of the load current, which is reflected as voltage on the CS pin. K is a constant value across the temperature and supply voltage. The current-sensing function operates normally within a wide linear region from 0 to 4 V. The CS pin can also report a fault by pulling up the voltage of $V_{CS,h}$.

The external high-accuracy current limit allows setting the current limit value by application. It highly improves the reliability of the system by clamping the inrush current effectively under start-up or short-circuit conditions. Also, it can save system costs by reducing PCB trace, connector size, and the preceding power-stage capacity. An internal current limit is also implemented in this device. The lower value of the external or internal current-limit value is applied.

An active drain and source voltage clamp is built in to address switching off the energy of inductive loads, such as relays, solenoids, pumps, motors, and so forth. During the inductive switching-off cycle, both the energy of the power supply (E_{BAT}) and the load (E_{LOAD}) are dissipated on the high-side power switch itself. With the benefits of process technology and excellent IC layout, the TPS1H100-Q1 device can achieve excellent power dissipation capacity, which can help save the external free-wheeling circuitry in most cases. See [Inductive-Load Switching-Off Clamp](#) for more details.

Short-circuit reliability is critical for smart high-side power-switch devices. The standard of AEC-Q100-012 is to determine the reliability of the devices when operating in a continuous short-circuit condition. Different grade levels are specified according to the pass cycles. This device is qualified with the highest level, Grade A, 1 million times short-to-GND certification.

The TPS1H100-Q1 device can be used as a high-side power switch for a wide variety of resistive, inductive, and capacitive loads, including the low-wattage bulbs, LEDs, relays, solenoids, and heaters.

7.2 Functional Block Diagram

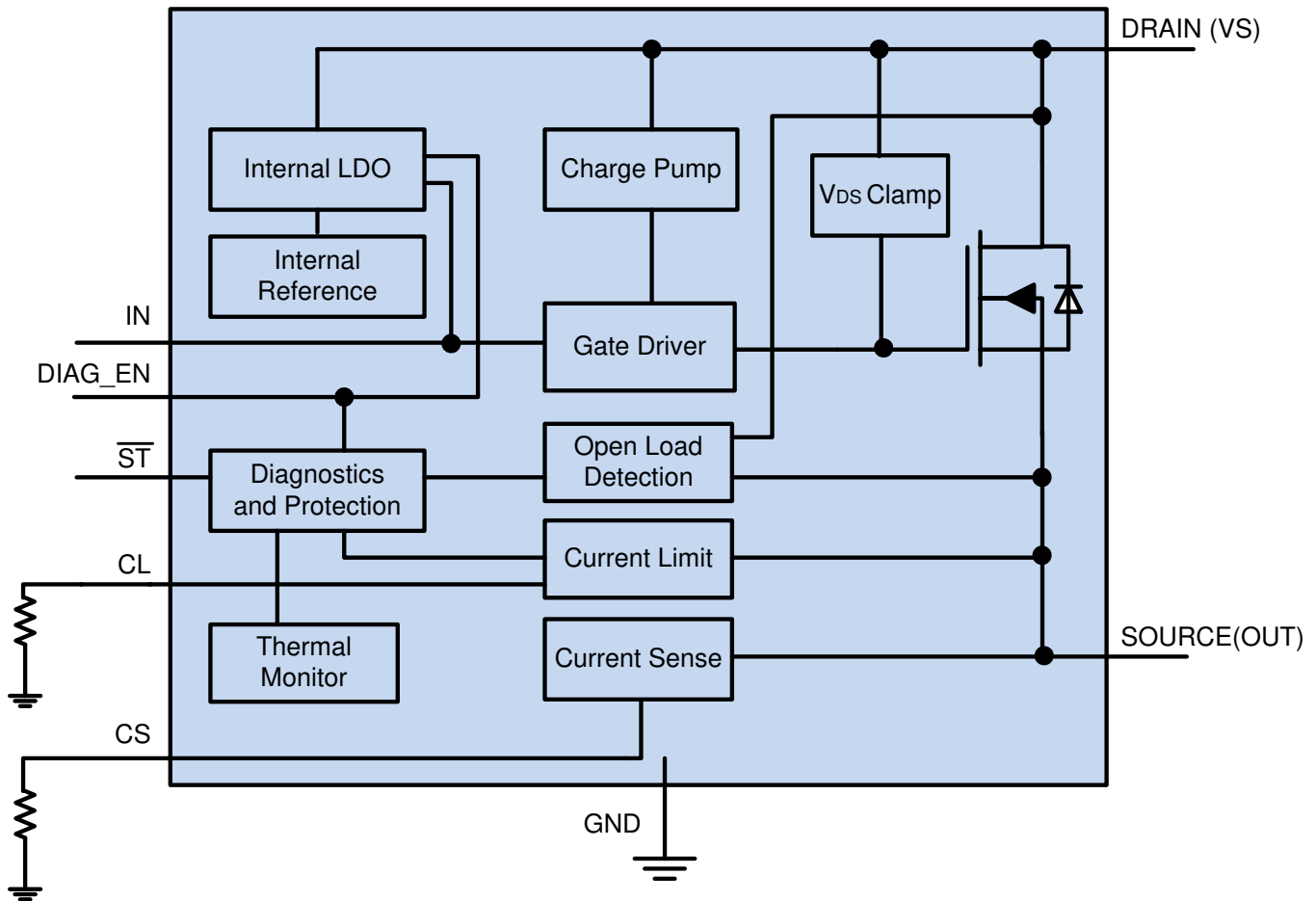

7.3 Feature Description

7.3.1 Accurate Current Sense

For version B, the high-accuracy current-sense function is internally implemented, which allows a better real-time monitoring effect and more-accurate diagnostics without further calibration. A current mirror is used to source $1 / K$ of the load current, flowing out to the external resistor between the CS pin and GND, and reflected as voltage on the CS pin.

K is the ratio of the output current and the sense current. It is a constant value across the temperature and supply voltage. Each device was internally calibrated while in production, so post-calibration by users is not required in most cases.

Feature Description (continued)

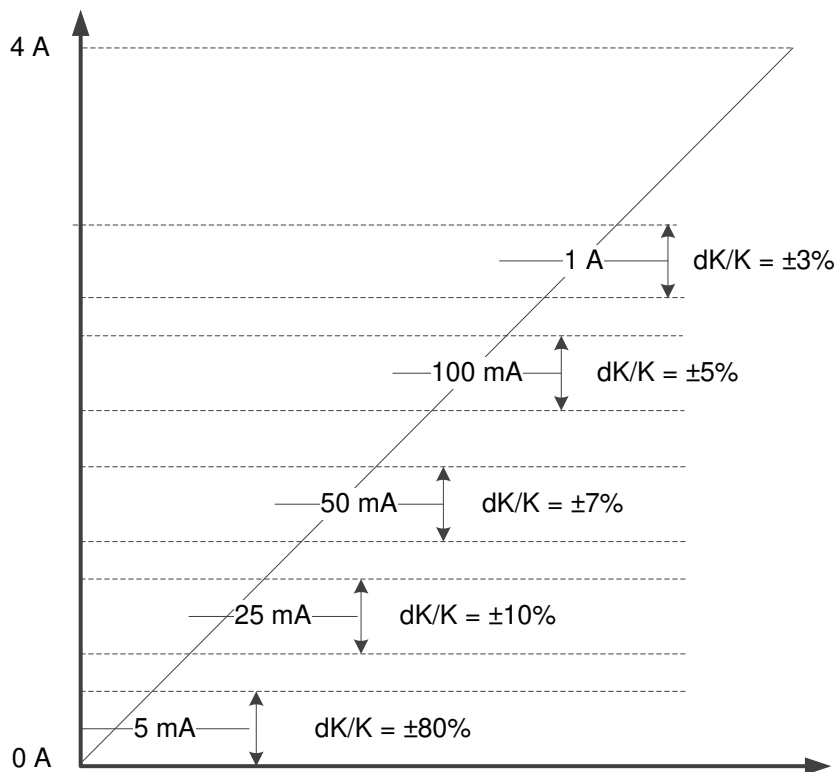
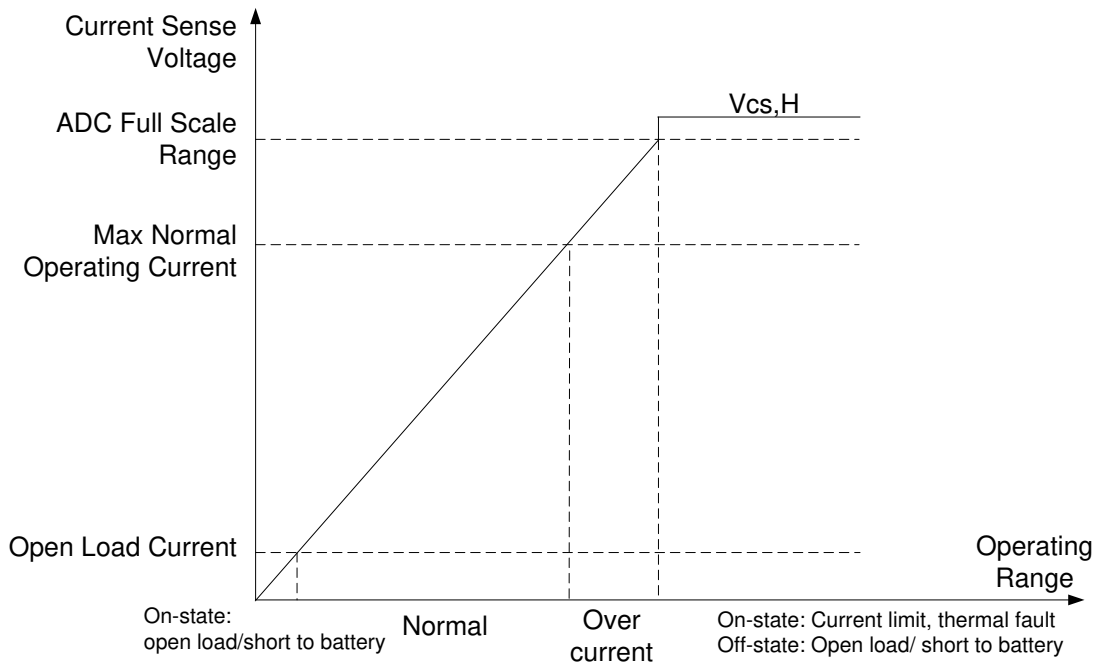
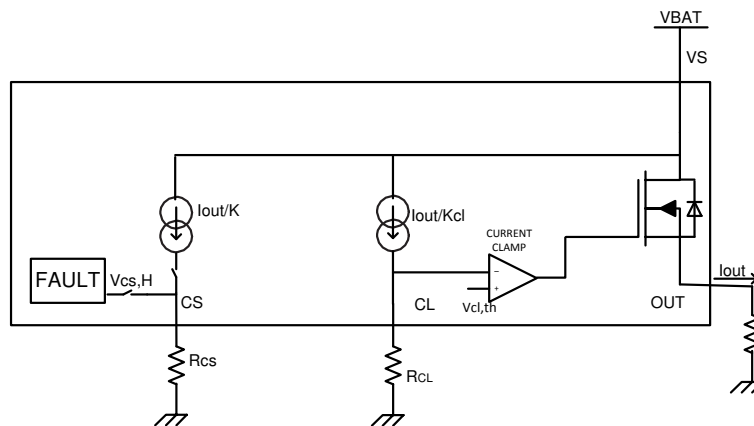

Figure 29. Current-Sense Accuracy

Ensure the CS voltage is in the linear region (0 to 4 V) during normal operation. Calculate R_{CS} with Equation 1.

$$R_{CS} = \frac{V_{CS}}{I_{CS}} = \frac{V_{CS} \times K}{I_{out}} \tag{1}$$

Also, when a fault condition occurs, CS works as a diagnostics report pin. When an open load or short to battery occurs in the on-state, V_{CS} almost equals 0. When current limit, thermal shutdown/swing, open load, or short to battery in the off-state occurs, the voltage is pulled up to $V_{CS,h}$. Figure 30 shows a typical current-sense voltage according to the operating conditions, including fault conditions.

Feature Description (continued)

Figure 30. Voltage Indication on the Current-Sense Pin

Figure 31. Current-Sense and Current-Limit Block Diagram
7.3.2 Programmable Current Limit

A high-accuracy current limit allows higher reliability, which protects the power supply during short circuit or power up. Also, it can save system costs by reducing PCB traces, connector size, and the capacity of the preceding power stage.

Current limit offers protection from overstressing to the load and integrated power FET. Current limit holds the current at the set value, and pulls up the CS pin to $V_{CS,h}$ as a diagnostic report. The two current-limit thresholds are:

- External programmable current limit -- An external resistor is used to convert a proportional load current into a voltage, which is compared with an internal reference voltage, $V_{th,cl}$. When the voltage on the CL pin exceeds $V_{th,cl}$, a closed loop steps in immediately. V_{GS} voltage regulates accordingly, leading to the V_{ds} voltage regulation. When the closed loop is set up, the current is clamped at the set value. The external programmable current limit provides the capability to set the current-limit value by application.

Feature Description (continued)

- Internal current limit -- The internal current limit is fixed and typically 10 A. To use the internal current limit for large-current applications, tie the CL pin directly to the device GND.

Both the internal current limit ($I_{lim,nom}$) and external programmable current limit are always active when V_{VS} is powered and IN is high. The lower one (of $I_{lim,nom}$ and the external programmable current limit) is applied as the actual current limit.

Note that if a GND network is used (which leads to the level shift between the device GND and board GND), the CL pin must be connected with device GND. Calculate R_{CL} with Equation 2.

$$I_{CL} = \frac{V_{CL,th}}{R_{CL}} = \frac{I_{out}}{K_{CL}} \rightarrow R_{CL} = \frac{V_{CL,th} \times K_{CL}}{I_{out}} \quad (2)$$

For better protection from a hard short-to-GND condition (when V_S and input are high and a short to GND happens suddenly), an open-loop fast-response behavior is set to turn off the channel, before the current-limit closed loop is set up. The open-loop response time is around 1 μ s. With this fast response, the device can achieve better inrush-suppression performance.

7.3.3 Inductive-Load Switching-Off Clamp

When an inductive load is switching off, the output voltage is pulled down to negative, due to the inductance characteristics. The power FET may break down if the voltage is not clamped during the current-decay period. To protect the power FET in this situation, internally clamp the drain-to-source voltage, namely $V_{DS,clamp}$, the clamp diode between the drain and gate.

$$V_{DS,clamp} = V_{BAT} - V_{OUT} \quad (3)$$

During the current-decay period (T_{DECAY}), the power FET is turned on for inductance-energy dissipation. Both the energy of the power supply (E_{BAT}) and the load (E_{LOAD}) are dissipated on the high-side power switch itself, which is called E_{HSD} . If resistance is in series with inductance, some of the load energy is dissipated in the resistance.

$$E_{HSD} = E_{BAT} + E_{LOAD} = E_{BAT} + E_L - E_R \quad (4)$$

From the high-side power switch's view, E_{HSD} equals the integration value during the current-decay period.

$$E_{HSD} = \int_0^{T_{DECAY}} V_{DS,clamp} \times I_{OUT}(t) dt \quad (5)$$

$$T_{DECAY} = \frac{L}{R} \times \ln\left(\frac{R \times I_{OUT(MAX)} + |V_{OUT}|}{|V_{OUT}|}\right) \quad (6)$$

$$E_{HSD} = L \times \frac{V_{BAT} + |V_{OUT}|}{R^2} \times \left[R \times I_{OUT(MAX)} - |V_{OUT}| \ln\left(\frac{R \times I_{OUT(MAX)} + |V_{OUT}|}{|V_{OUT}|}\right) \right] \quad (7)$$

When R approximately equals 0, E_{HSD} can be given simply as:

$$E_{HSD} = \frac{1}{2} \times L \times I_{OUT(MAX)}^2 \times \frac{V_{BAT} + |V_{OUT}|}{R^2} \quad (8)$$

Feature Description (continued)

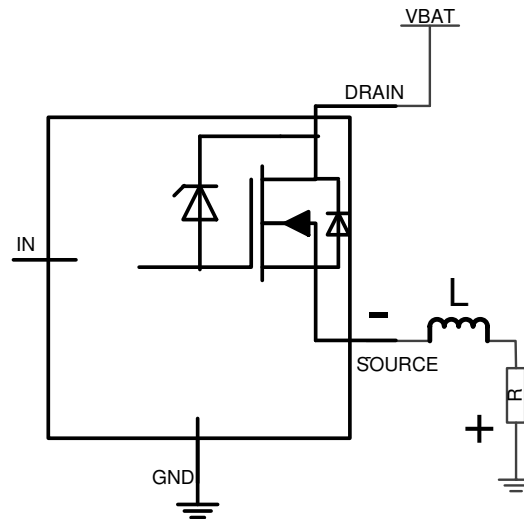

Figure 32. Driving Inductive Load

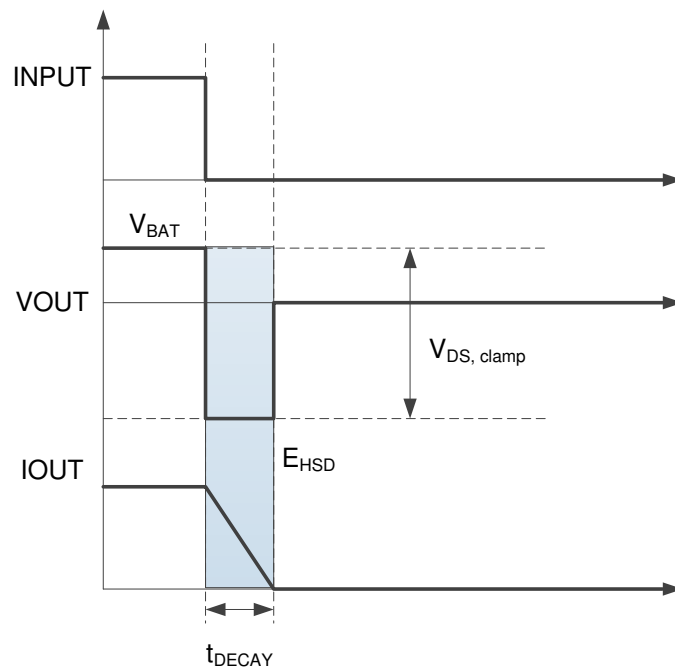

Figure 33. Inductive-Load Switching-Off Diagram

As discussed previously, when switching off, battery energy and load energy are dissipated on the high-side power switch, which leads to the large thermal variation. For each high-side power switch, the upper limit of the maximum safe power dissipation depends on the device intrinsic capacity, ambient temperature, and board dissipation condition. TI provides the upper limit of single-pulse energy that devices can tolerate under the test condition: $V_{VS} = 13.5\text{ V}$, inductance from 0.1 mH to 400 mH, $R = 0\ \Omega$, FR4 2s2p board, 2- x 70- μm copper, 2- x 35- μm copper, thermal pad copper area 600 mm^2 .

For one dedicated inductance, see Figure 34. If the maximum switching-off current is lower than the current value shown on the curve, the internal clamp function can be used for the demagnetization energy dissipation. If not, external free-wheeling circuitry is necessary for device protection.

Feature Description (continued)

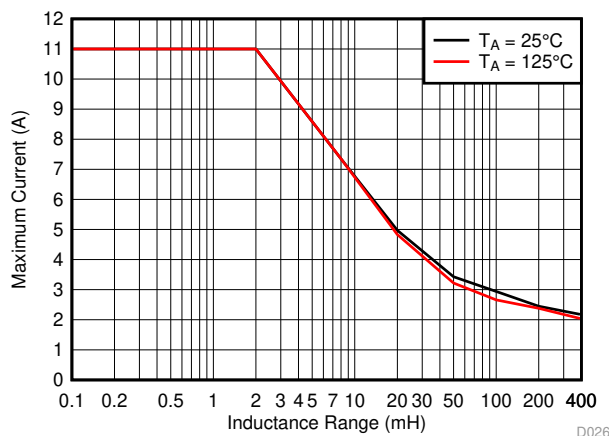

Figure 34. Maximum Current vs Inductance Range

7.3.4 Full Protections and Diagnostics

Table 1 is when DIAG_EN enabled. When DIAG_EN is low, current sense or ST is disabled accordingly. The output is in high-impedance mode. Refer to Table 2 for details.

Table 1. Fault Table

CONDITIONS	IN	OUT	CRITERION	ST (Version A)	CS (Version B)	Diagnostics Recovery
Normal	L	L		H	0	
	H	H		H	In linear region	
Short to GND	H	L	Current limit triggered.	L	V _{CS,h}	AUTO
Open load ⁽¹⁾ Short to battery Reverse polarity	H	H	Version A: Output current < I _{ol,on} Version B: Judged by users	L (deglitch)	Almost 0	AUTO
	L	H	V _{VS} - V _{OUT} < V _{ol,off}	L (deglitch)	V _{CS,h} (deglitch)	AUTO
Thermal shutdown	H		TSD triggered	L	V _{CS,h}	Recovery when temp < T _{SD,rst}
Thermal swing	H		T _{sw} triggered	L	V _{CS,h}	AUTO

(1) Need external pullup resistor during off-state

Table 2. DIAG_EN Logic Table

DIAG_EN	IN Condition	Protections and Diagnostics
HIGH	ON	See Table 1
	OFF	See Table 1
LOW	ON	Diagnostics disabled, protection normal CS or ST is high Impedance
	OFF	Diagnostics disabled, no protections CS or ST is high impedance

7.3.4.1 Short-to-GND and Overload Detection

In the on state, the short-to-GND fault is reported as the low status output or $V_{CS,h}$ on CS, when a current limit is triggered. The lower one of the internal and external set values is applied for the actual current limit. It is in auto-recovery when the fault condition is cleared. If not cleared, thermal shutdown triggers to protect the power FET.

7.3.4.2 Open-Load Detection

In the on state for version A, if the current flowing through the output is less than $I_{ol,on}$, the device recognizes an open-load fault. For version B, faults are diagnosed by reading the voltage on the CS pin and judged by the user. A benefit of high-accuracy current sense down to a verylow current range, this device can achieve a very low open-load detection threshold, which correspondingly expands the normal operation region. TI suggests 10 mA as the upper limit for the open-load detection threshold and 25 mA as the lower limit for the normal operation current. In Figure 35, the recommended open-load detection region is shown as the dark-shaded region and the light-shaded region is for normal operation. As a guideline, do not overlap these two regions.

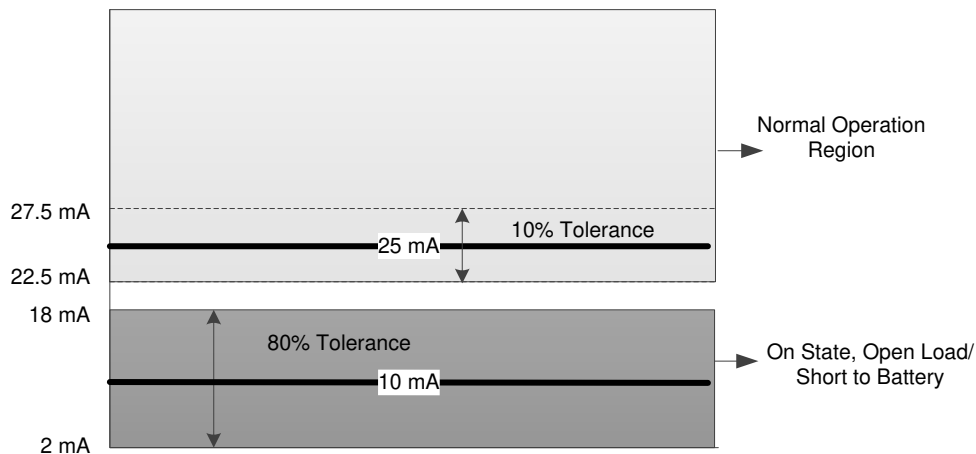

Figure 35. On-State Open-Load Detection and Normal-Operation Diagram

In the off state, if a load is connected, the output voltage is pulled to 0 V. In the case of an open load, the output voltage is close to the supply voltage, $V_S - V_{OUT} < V_{ol,off}$. For version A, the ST pin goes low to indicate the fault to the MCU. For version B, the CS pin is pulled up to $V_{CS,h}$. There is always a leakage current $I_{ol,off}$ present on the output, due to the internal logic control path or external humidity, corrosion, and so forth. Thus, TI recommends an external pullup resistor to offset the leakage current. This pullup current should be less than the output load current to avoid false detection in the normal operation mode. To reduce the standby current, TI recommends always to use a switch in series with the pullup resistor. TI recommends $R_{pu} \leq 15 \text{ k}\Omega$.

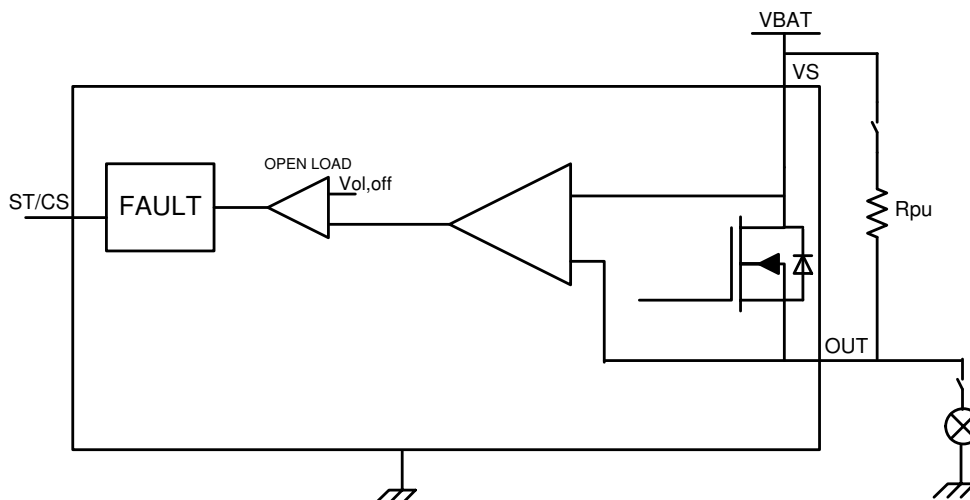

Figure 36. Open-Load Detection Circuit

7.3.4.3 Short-to-Battery Detection

Short-to-battery detection has the same detection mechanism and behavior as open-load detection, both in the on-state and off-state. See the fault truth table, [Table 1](#), for more details. In the on-state, the reverse current flows through the FET instead of the body diode, leading to less power dissipation. Thus, the worst case for off-state is when reverse current occurs. In the off-state, if $V_{OUT} - V_{VS} < V_F$, short to battery can be detected. (V_F is the body diode forward voltage and typically 0.7 V.) However, the reverse current does not occur. If $V_{OUT} - V_{VS} > V_F$, short to battery can be detected, and the reverse current should be lower than I_{rev2} to ensure the survival of the device. TI recommends switching on the input for lower power dissipation or the reverse block circuitry for the supply. See [Reverse Current Protection](#) for more external protection circuitry information.

7.3.4.4 Reverse-Polarity Detection

Reverse-polarity detection has the same detection mechanism and behavior as open-load detection, both in the on-state and off-state. See the fault truth table, [Table 1](#), for more details. In the on-state, the reverse current flows through the FET instead of the body diode, leading to less power dissipation. Thus, the worst case off-state is when reverse current occurs. In off-state, the reverse current should be lower than I_{rev1} to ensure the survival of the device. See [Reverse Current Protection](#) for more external protection circuitry information.

7.3.4.5 Thermal Protection Behavior

Both the absolute temperature thermal shutdown and the dynamic temperature thermal swing diagnostic and protection are built into the device to increase the maximum reliability of the power FET. Thermal swing is active when the temperature of the power FET is increasing sharply, that is $\Delta T = T_{DMOS} - T_{Logic} > T_{sw}$, then the output is shut down, and the ST pin goes low, or the CS pin is pulled up to $V_{CS,h}$. It auto-recovers and clears the fault signal until $\Delta T = T_{DMOS} - T_{Logic} < T_{sw} - T_{hys}$. Thermal swing function improves device reliability against repetitive fast thermal variation, as shown in [Figure 37](#). Multiple thermal swings are triggered before thermal shutdown happens. Thermal shutdown is active when absolute temperature $T > T_{SD}$. When active, the output is shut down, and the ST pin goes low, or the CS pin is pulled up to $V_{CS,h}$. The output is auto-recovered when $T < T_{SD} - T_{hys}$; the current limit is reduced to $I_{lim,tsd}$, or half of the programmable current limit value, to avoid repeated thermal shutdown. However, the thermal shutdown fault signal and half-current limit value are not cleared until the junction temperature decreases to less than $T_{SD,rst}$.

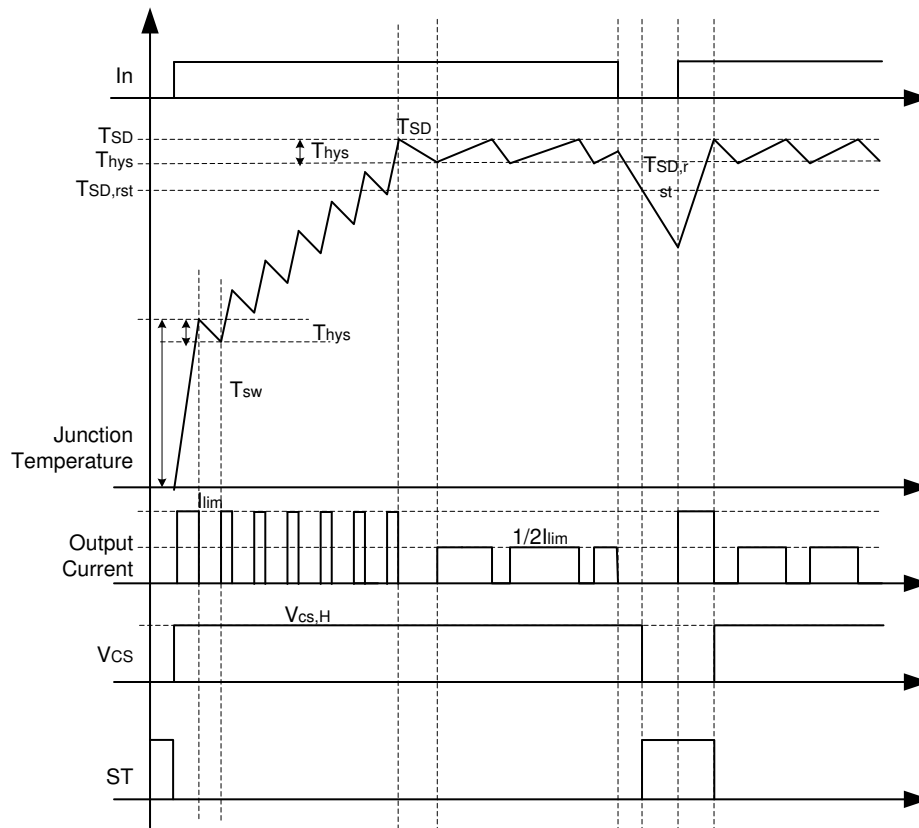

Figure 37. Thermal Behavior

7.3.4.6 UVLO Protection

The device monitors the supply voltage V_{VS} to prevent unpredicted behaviors in the event that the supply voltage is too low. When the supply voltage falls down to $V_{VS,UVF}$, the output stage is shut down automatically. When the supply rises up to $V_{VS,UVR}$, the device turns on.

7.3.4.7 Loss of GND Protection

When loss of GND occurs, output is turned off regardless of whether the input signal is high or low.

Case 1 (loss of device GND): Loss of GND protection is active when the Tab, I_{C_GND} , and current limit GND are one trace connected to the board GND, as shown in Figure 38. Tab floating is also a choice.

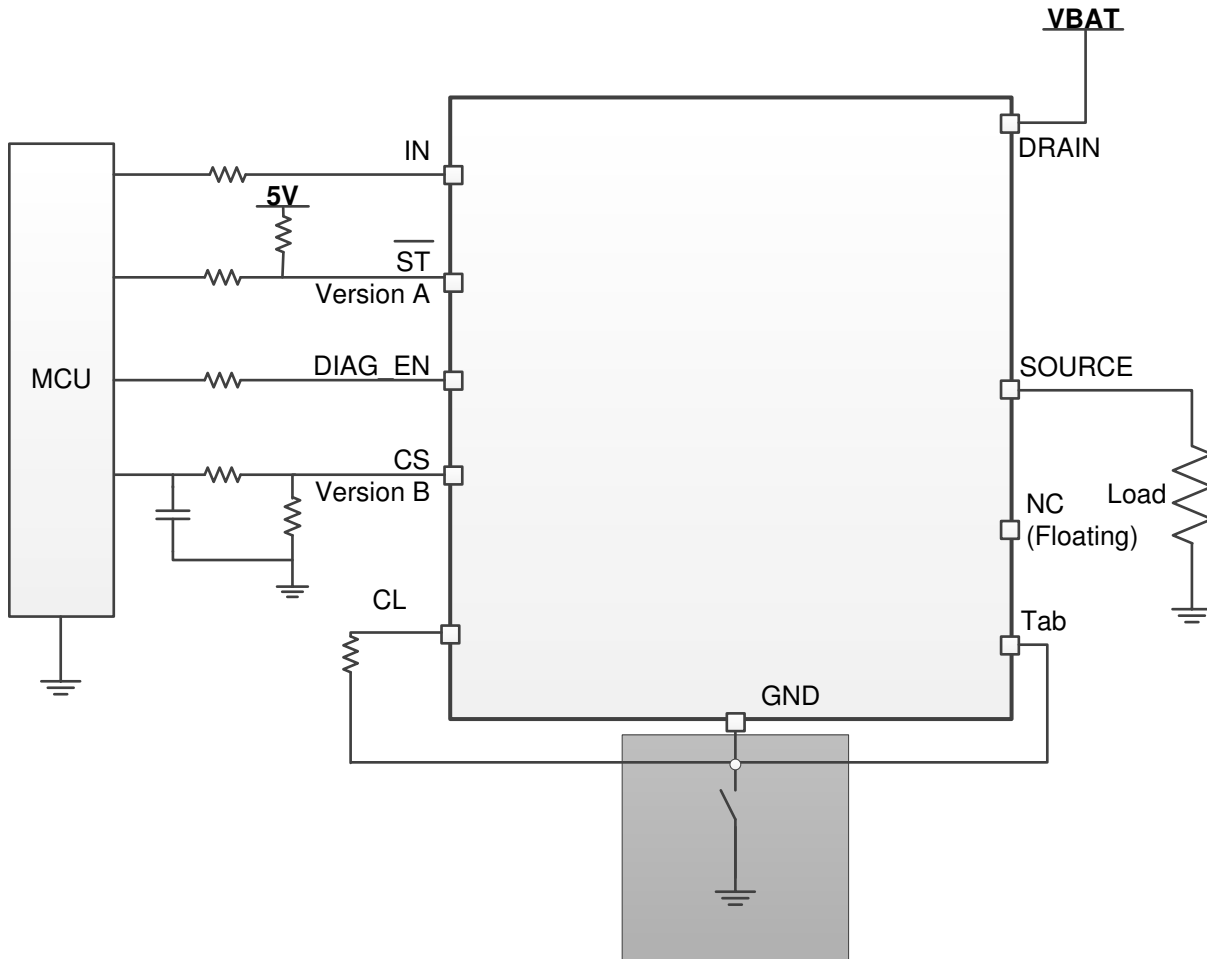

Figure 38. Loss of Device GND

Case 2 (loss of module GND): When the whole ECU module GND is lost, protections are also active. At this condition, the load GND remains connected.

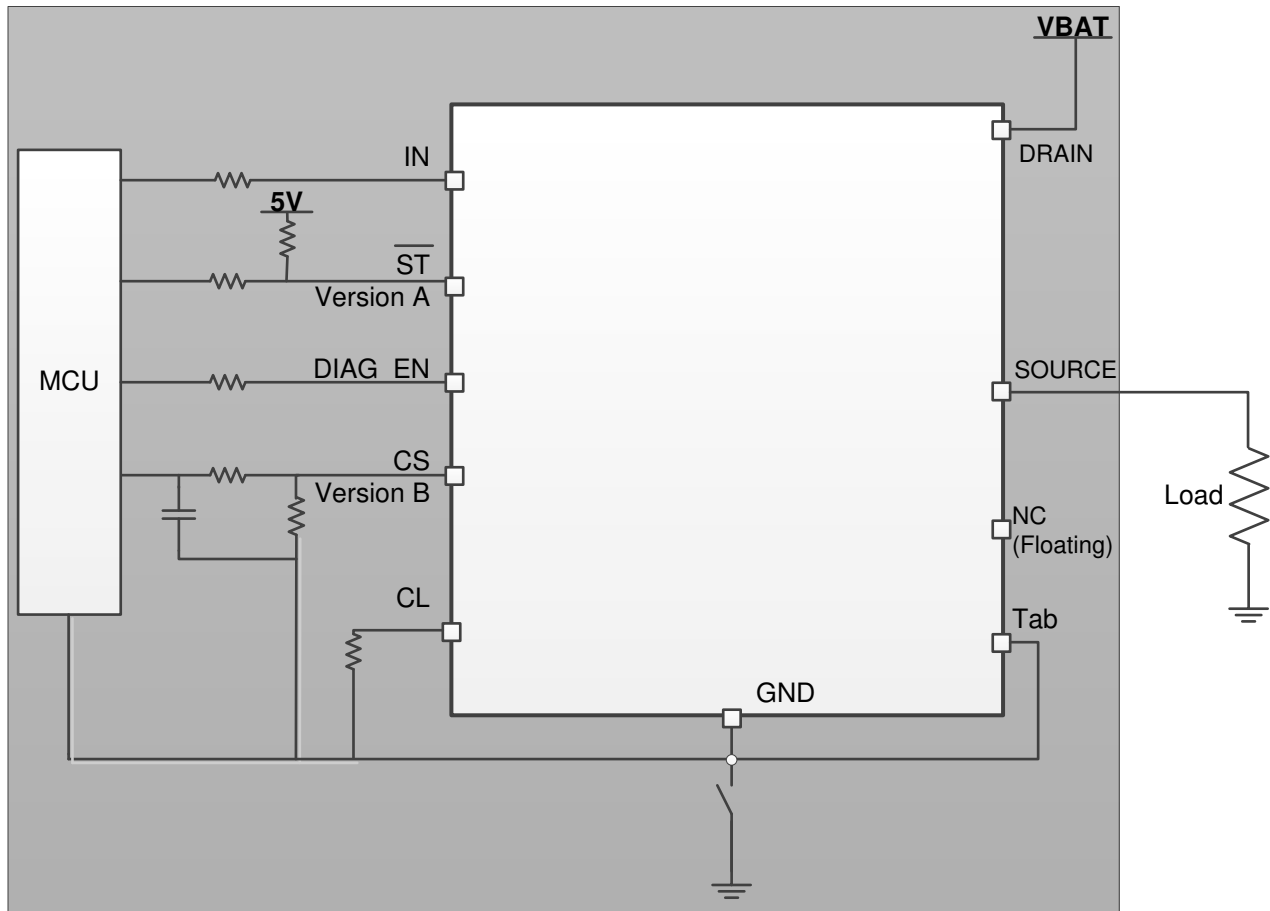

Figure 39. Loss of Module GND

7.3.4.8 Loss of Power Supply Protection

When loss of supply occurs, output is turned off regardless of whether the input is high or low. For a resistive or capacitive load, loss-o-supply protection is easy to achieve due to no more power. The worst case is a charged inductive load. In this case, the current is driven from all of the IOs to maintain the inductance output loop. TI recommends either the MCU serial resistor plus the GND network (diode and resistor in parallel) or external free-wheeling circuitry.

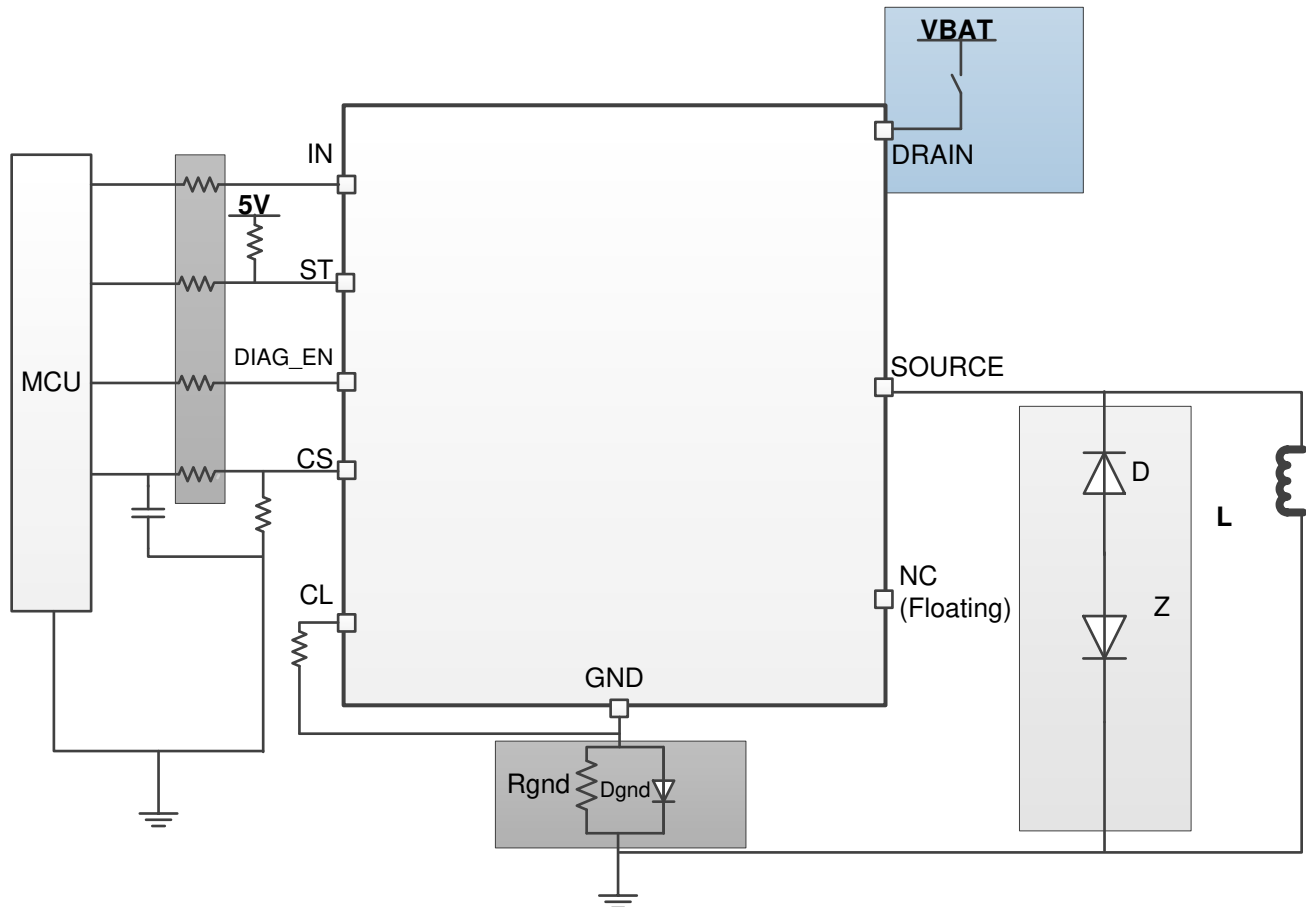

Figure 40. Loss of Battery

Method 2 (GND network protection): Only the high-side device is protected under this connection. The load reverse loop is limited by the load itself. Note when reverse polarity happens, the continuous reverse current through the power FET should be less than I_{rev} . Of the three types of ground pin networks, TI strongly recommends type 3 (the resistor and diode in parallel). No matter what types of connection are between the device GND and the board GND, if a GND voltage shift happens, ensure the following proper connections for the normal operation:

- Leave the NC pin floating or connect to the device GND. TI recommends to leave floating.
- Connect the current limit programmable resistor to the device GND.

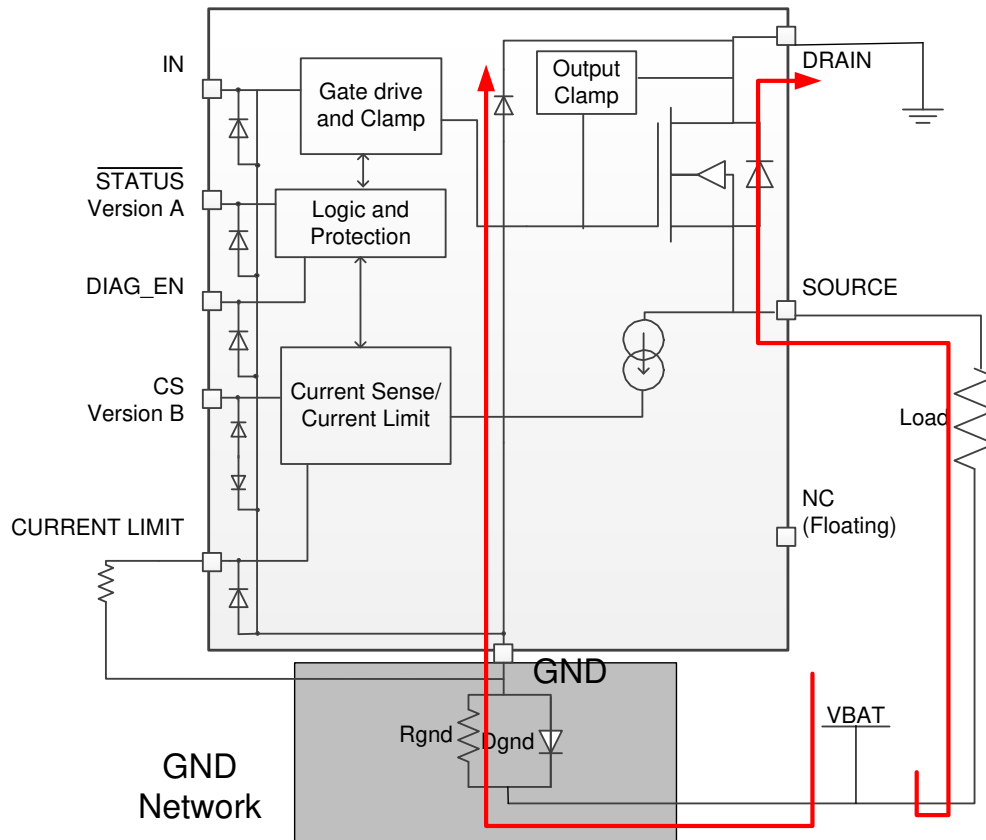

Figure 42. Reverse Protection With GND Network

- **Type 1 (resistor):** The higher resistor value contributes to a better current limit effect when the reverse battery or negative ISO pulses. However, it leads to higher GND shift during normal operation mode. Also, consider the resistor's power dissipation.

$$R_{GND} \leq \frac{V_{GNDshift}}{I_{nom}} \tag{9}$$

$$R_{GND} \geq \frac{-V_{CC}}{-I_{GND}}$$

where

- $V_{GNDshift}$ is the maximum value for the GND shift, determined by the HSD and microcontroller. TI suggests a value ≤ 0.6 V.
- I_{nom} is the nominal operating current.
- $-V_{CC}$ is the maximum reverse voltage seen on the battery line.
- $-I_{GND}$ is the maximum reverse current the ground pin can withstand, which is available in the [Absolute Maximum Ratings](#).

(10)

If multiple high-side power switches are used, the resistor can be shared among devices.

- **Type 2 (diode):** A diode is needed to block the reverse voltage, which also brings a ground shift (≈ 600 mV).

However, an inductive load is not acceptable to avoid an abnormal status when switching off.

- Type 3 (resistor and diode in parallel (recommended)):** A peak negative spike may occur when the inductive load is switching off, which may damage the HSD or the diode. So, TI recommends a resistor in parallel with the diode when driving an inductive load. The recommended selection are 1-k Ω resistor in parallel with an $I_F > 100$ -mA diode. If multiple high-side switches are used, the resistor and diode can be shared among devices.

7.3.4.10 Protection for MCU I/Os

In many conditions, such as the negative ISO pulse, or the loss of battery with an inductive load, a negative potential on the device GND pin may damage the MCU I/O pins [more likely, the internal circuitry connected to the pins]. Therefore, the serial resistors between MCU and HSD are required.

Also, for proper protection against loss of GND, TI recommends 4.7 k Ω when using 3.3-V MCU I/Os; 10 k Ω is for 5-V applications.

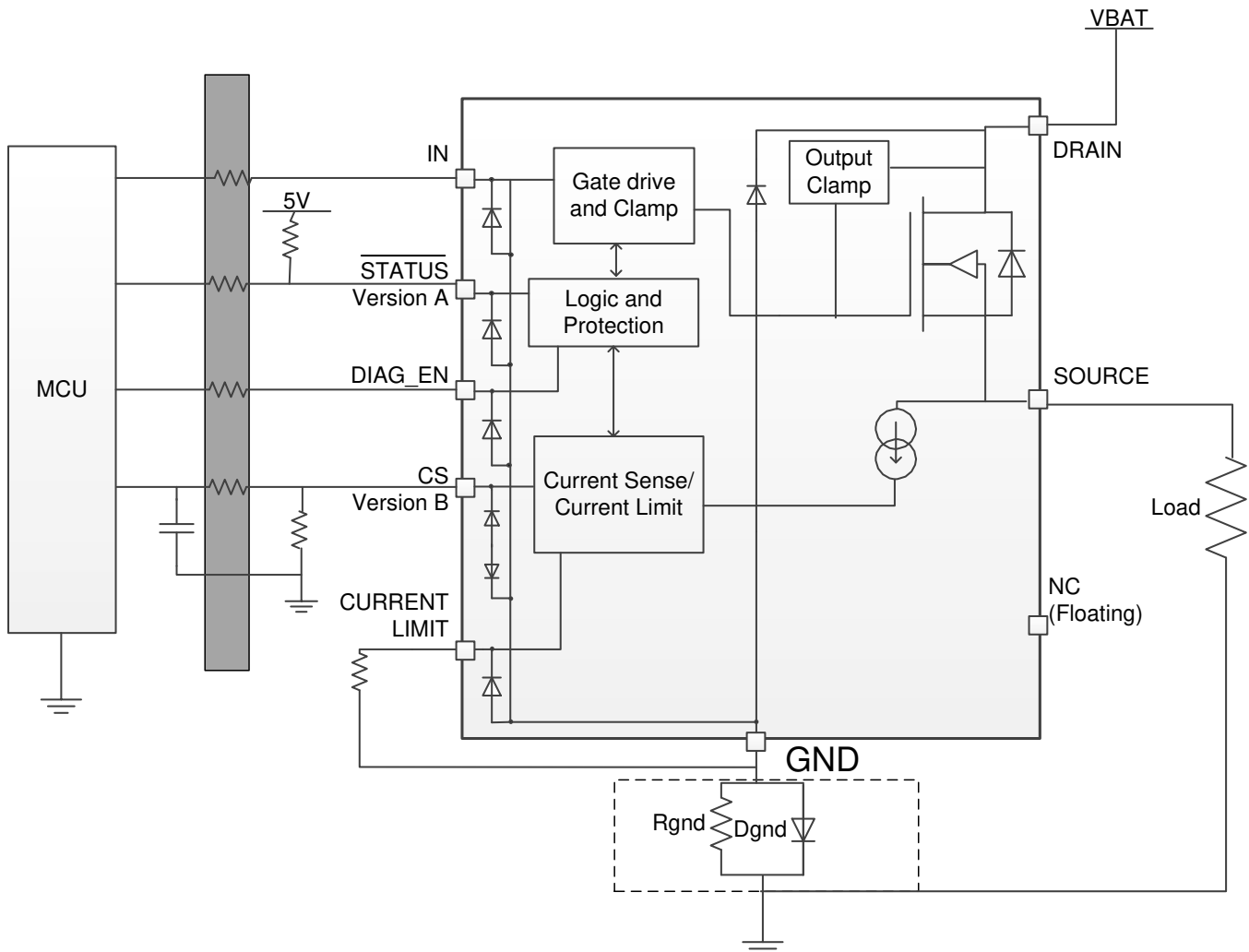

Figure 43. MCU IO Protections

7.3.5 Diagnostic Enable Function

The diagnostic enable pin, DIAG_EN, offers multiplexing of the microcontroller diagnostic input for current sense or digital status, by sharing the same sense resistor and ADC line or I/O port among multiple devices.

In addition, during the output-off period, the diagnostic disable function lowers the current consumption for the standby condition. The three working modes in the device are normal mode, standby mode, and standby mode with diagnostic. If off-state power saving is required in the system, the standby current is <math><500\text{ nA}</math> with DIAG_EN low. If the off-state diagnostic is required in the system, the typical standby current is around 1 mA with DIAG_EN high.

7.4 Device Functional Modes

7.4.1 Working Mode

The three working modes in the device are normal mode, standby mode, and standby mode with diagnostic. If an off-state power saving is required in the system, the standby current is less than 500 nA with DIAG_EN low. If an off-state diagnostic is required in the system, the typical standby current is around 1 mA with DIAG_EN high. Note that to enter standby mode requires IN low and $t > t_{\text{off,deg}}$. $t_{\text{off,deg}}$ is the standby-mode deglitch time, which is used to avoid false triggering. Figure 44 shows a work-mode state-machine state diagram.

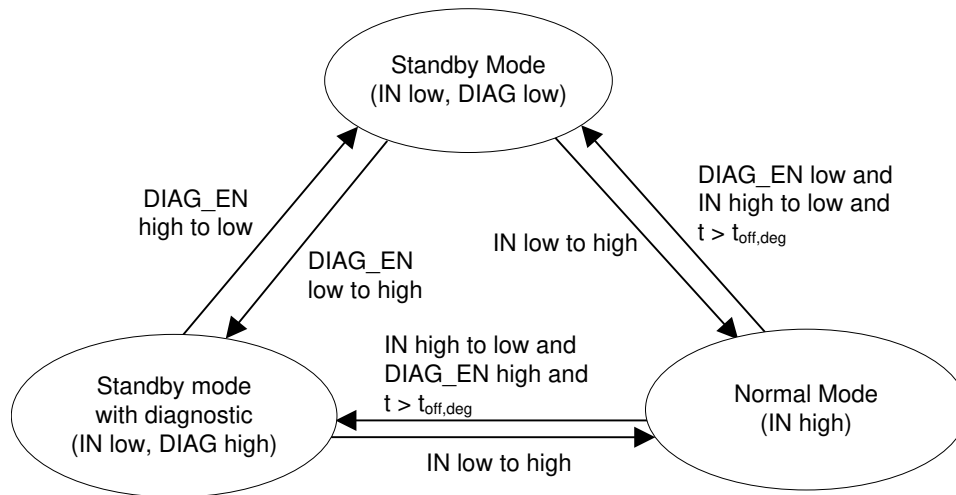

Figure 44. Work-Mode State Machine

8 Application and Implementation

NOTE

Information in the following applications sections is not part of the TI component specification, and TI does not warrant its accuracy or completeness. TI's customers are responsible for determining suitability of components for their purposes. Customers should validate and test their design implementation to confirm system functionality.

8.1 Application Information

The following discussion notes how to implement the device to distinguish the different fault modes and implement a ? transient-pulse immunity test.

In some applications, open load, short to battery, and short to GND must be distinguished from each other. This requires two steps.

8.2 Typical Application

Figure 45 shows an example of how to design the external circuitry parameters.

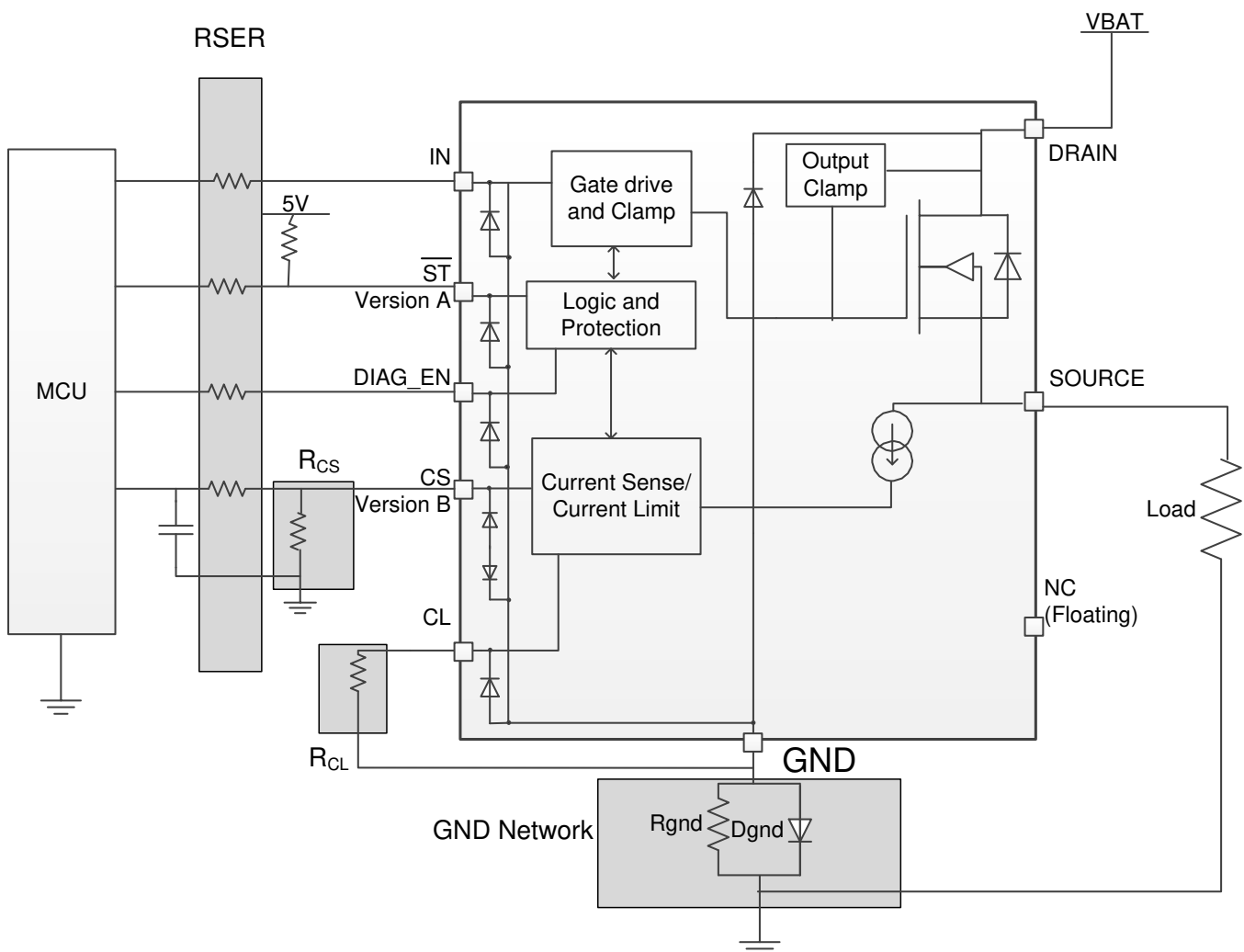

Figure 45. Typical Application Circuitry

Typical Application (continued)

8.2.1 Design Requirements

- V_S range from 9 V to 16 V
- Nominal current of 2 A
- Current sense for fault monitoring
- Expected current limit value of 5 A
- Full diagnostics with 5-V MCU
- Reverse protection with GND network

8.2.2 Detailed Design Procedure

The R_{CS} , V_{CS} linear region is from 0 to 4 V. To keep the 2-A nominal current in the 0- to 3-V range, calculate the R_{CS} as in [Equation 11](#). To achieve better current sense accuracy, a 1% accuracy or better resistor is preferred.

$$R_{CS} = \frac{V_{CS}}{I_{CS}} = \frac{V_{CS} \times K}{I_{OUT}} = \frac{3 \times 500}{2} = 750 \, \Omega \quad (11)$$

R_{CL} , $V_{CL,th}$ is the current-limit internal threshold, 1.233 V. To set the programmable current limit value at 5 A, calculate the R_{CL} as in [Equation 12](#).

$$R_{CL} = \frac{V_{cl,th} \times K_{CL}}{I_{OUT}} = \frac{1.233 \times 2000}{5} = 493.2 \, \Omega \quad (12)$$

TI recommends $R_{SER} = 10 \, k\Omega$ for 5-V MCU.

TI recommends a 1-k Ω resistor and 200-V, 0.2-A diode for the GND network.

8.2.2.1 Distinguishing of Different Fault Modes

Some applications require that open load, short to battery, and short to GND can be distinguished from each other. This requires two steps:

1. In the on-state, for the current-sense version device (version B), on-state open load and short to battery are recognized as an extremely-low voltage level on the current-sense pin, whereas short to GND is reported as a pulled-up voltage $V_{CS,h}$. Therefore, the user can find a short to GND (see [Figure 46](#)).
2. If reported as an on-state open-load or short-to-battery fault in the first step, turn off the input signal. In the off-state, with an external pulldown resistor, open load and short to battery can be easily distinguished. When the output pulls down, the short to battery is still reported as an off-state fault condition, whereas the open load is ignored.

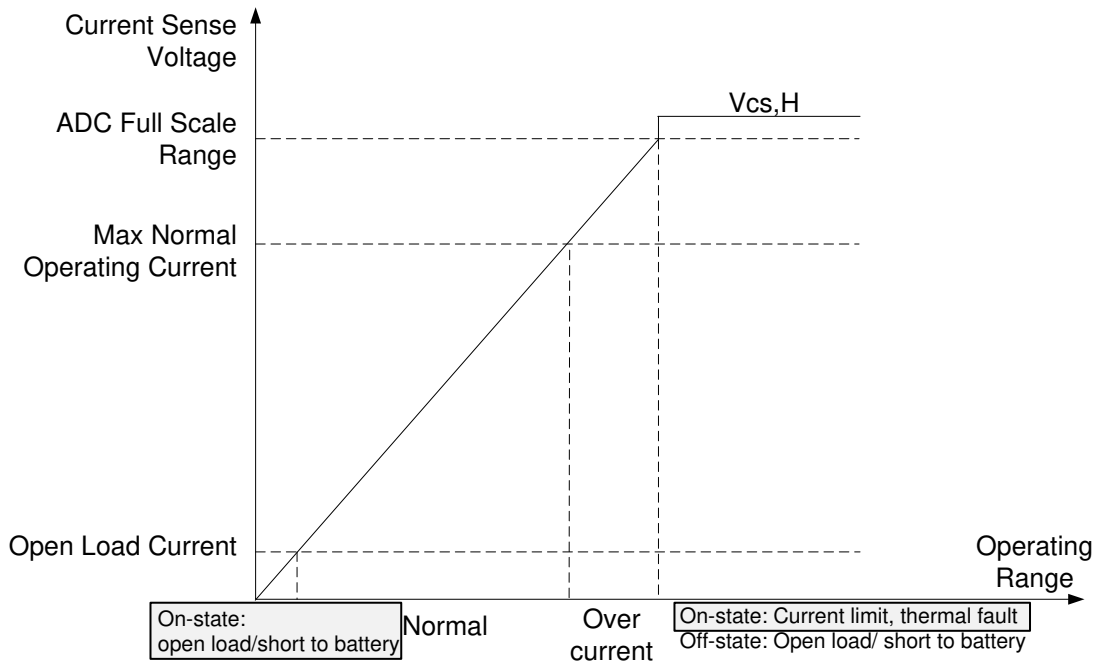
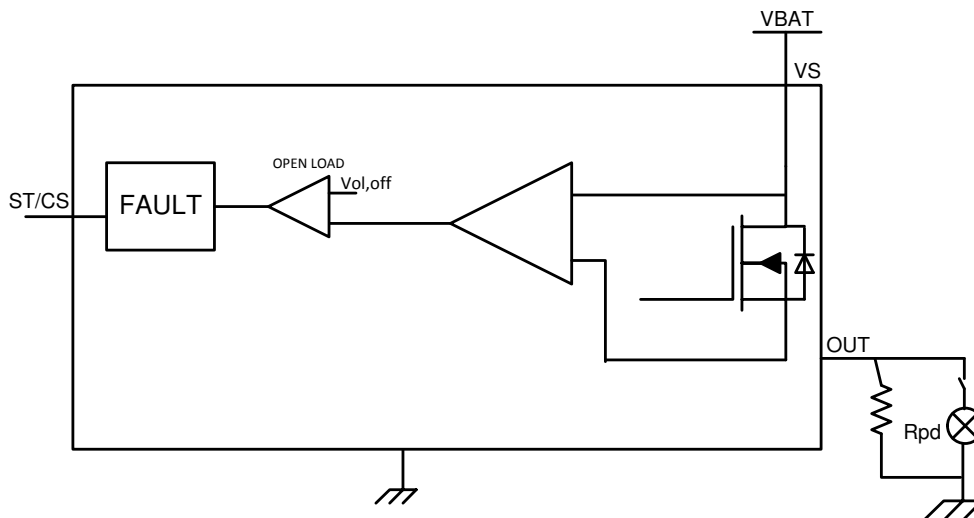
Typical Application (continued)

Figure 46. Step 1: Short-to-GND Detection in the On-State

Figure 47. Step 2: Short-to-Battery Detection in the Off-State
8.2.2.2 AEC Q100-012 Test Grade A Certification

Short-circuit reliability is critical for smart high-side power switch devices. The AEC-Q100-012 standard is used to determine the reliability of the devices when operating in a continuous short-circuit condition. Different grade levels are specified according to the pass cycles. This device is qualified with the highest level, Grade A, 1 million times short-to-GND certification.

Three test modes are defined in the AEC Q100-012 standard. See [Table 3](#) for cold repetitive short-circuit test – long pulse, cold repetitive short-circuit test – short pulse, and hot repetitive short-circuit test.

Typical Application (continued)

Table 3. Tests

Test Items	Test Condition	Test Cycles
Cold repetitive short-circuit test – short pulse	–40°C, 10-ms pulse, cool down	1M
Cold repetitive short-circuit test – long pulse	–40°C, 300-ms pulse, cool down	1M
Hot repetitive short-circuit test	25°C, continuous short	1M

Different grade levels are specified according to the pass cycles. The TPS1H100-Q1 device gets the certification of Grade A level, 1 million short-to-GND cycles, which is the highest test standard in the market.

Table 4. Grade Levels

Grade	Number of Cycles	Lots, Samples Per Lot	Number of Fails
A	>1000000	3, 10	0
B	>300000 to 1000000	3, 10	0
C	>100000 to 300000	3, 10	0
D	>30000 to 100000	3, 10	0
E	>10000 to 30000	3, 10	0
F	>3000 to 10000	3, 10	0
G	>1000 to 3000	3, 10	0
H	300 to 1000	3, 10	0
O	<300	3, 10	0

8.2.2.3 EMC Transient Disturbances Test

Due to the severe electrical conditions in the automotive environment, immunity capacity against electrical transient disturbances is required, especially for a high-side power switch, which is connected directly to the battery. Detailed test requirements are in accordance with the ISO 7637-2:2011 and ISO 16750-2:2010 standards. The TPS1H100-Q1 device is tested and certificated by a third-party organization.

Table 5. ISO 7637-2:2011(E) in 12-V System⁽¹⁾⁽²⁾⁽³⁾⁽⁴⁾

Test Item	Test Pulse Severity Level and vs Accordingly		Pulse Duration (t_d)	Minimum Number of Pulses or Test Time	Burst-Cycle Pulse-Repetition Time		Input Resistance (Ω)	Function Performance Status Classification
	Level	Vs/V			MIN	MAX		
1	III	–112	2 ms	500 pulses	0.5 s	e s	10	Status II
2a	III	55	50 μ s	500 pulses	0.2 s	5 s	2	Status II
2b	IV	10	0.2 to 2 s	10 pulses	0.5 s	5 s	0 to 0.05	Status II
3a	IV	–220	0.1 μ s	1h	90 ms	100 ms	50	Status II
3b	IV	150	0.1 μ s	1h	90 ms	100 ms	50	Status II

- (1) Tested both under input low condition and high condition.
- (2) Considering the worst test condition, it is tested without any filter capacitors in V_S and V_{OUT} .
- (3) GND pin network is a 1-k Ω resistor in parallel with a diode BAS21-7-F.
- (4) Status II: The function does not perform as designed during the test, but returns automatically to normal operation after the test.

Table 6. ISO 16750-2:2010(E) Load Dump Test B in 12-V System⁽¹⁾⁽²⁾⁽³⁾⁽⁴⁾⁽⁵⁾

Test Item	Test Pulse Severity Level and vs Accordingly		Pulse Duration (t_d)	Minimum Number of Pulses or Test Time	Burst Cycle/Pulse Repetition Time		Input Resistance (Ω)	Function Performance Status Classification
	Level	Vs/V			MIN (s)	MAX (s)		
Test B		45	40 to 400 ms	5 pulses	60	e	0.5 to 4	Status II

- (1) Tested both under input low condition and high condition. [DIAG_EN, IN, and VS are all classified as inputs. Which one?
- (2) Considering the worst test condition, the device is tested without any filter capacitors on VS and OUT.
- (3) The GND pin network is a 1-k Ω resistor in parallel with a diode BAS21-7-F.
- (4) Status II: The function does not perform as designed during the test, but returns automatically to normal operation after the test.
- (5) Select a 45-V external suppressor.

8.2.3 Application Curves

Figure 48 shows a test example of initial short-circuit inrush-current limit. Test conditions: $V_S = 13.5\text{ V}$, input is from low to high, load is short-to-GND or with a $470\text{-}\mu\text{F}$ capacitive load, external current limit is 2 A . CH1 is the output current. CH3 is the input step.

Figure 49 shows a test example of a hard short-circuit inrush-current limit. Test conditions: $V_S = 13.5\text{ V}$, input is high, load is $5\text{ }\mu\text{H} + 100\text{ m}\Omega$, external current limit is 1 A . A short to GND suddenly happens.

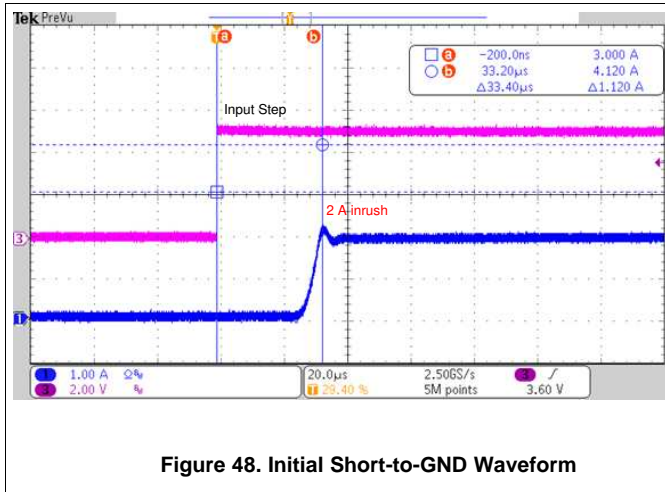

Figure 48. Initial Short-to-GND Waveform

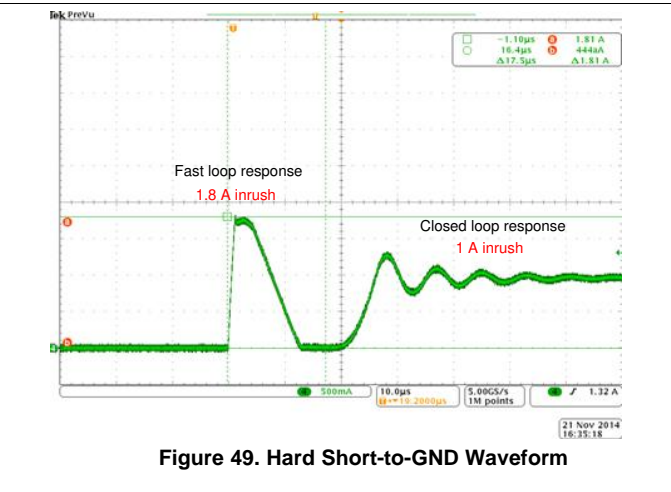

Figure 49. Hard Short-to-GND Waveform

9 Power Supply Recommendations

The device is qualified for both automotive and industrial applications. The normal power supply connection is a 12-V automotive system or 24-V industrial system. The supply voltage should be within the range specified in the [Recommended Operating Conditions](#).

10 Layout

10.1 Layout Guidelines

To prevent thermal shutdown, T_J must be less than 150°C. If the output current is very high, the power dissipation may be large. The HTSSOP package has good thermal impedance. However, the PCB layout is very important. Good PCB design can optimize heat transfer, which is absolutely essential for the long-term reliability of the device.

- Maximize the copper coverage on the PCB to increase the thermal conductivity of the board. The major heat-flow path from the package to the ambient is through the copper on the PCB. Maximum copper is extremely important when there are not any heat sinks attached to the PCB on the other side of the board opposite the package.
- Add as many thermal vias as possible directly under the package ground pad to optimize the thermal conductivity of the board.
- All thermal vias should either be plated shut or plugged and capped on both sides of the board to prevent solder voids. To ensure reliability and performance, the solder coverage should be at least 85%.

10.2 Layout Example

10.2.1 Without a GND Network

Without a GND network, tie the thermal pad directly to the board GND copper for better thermal performance.

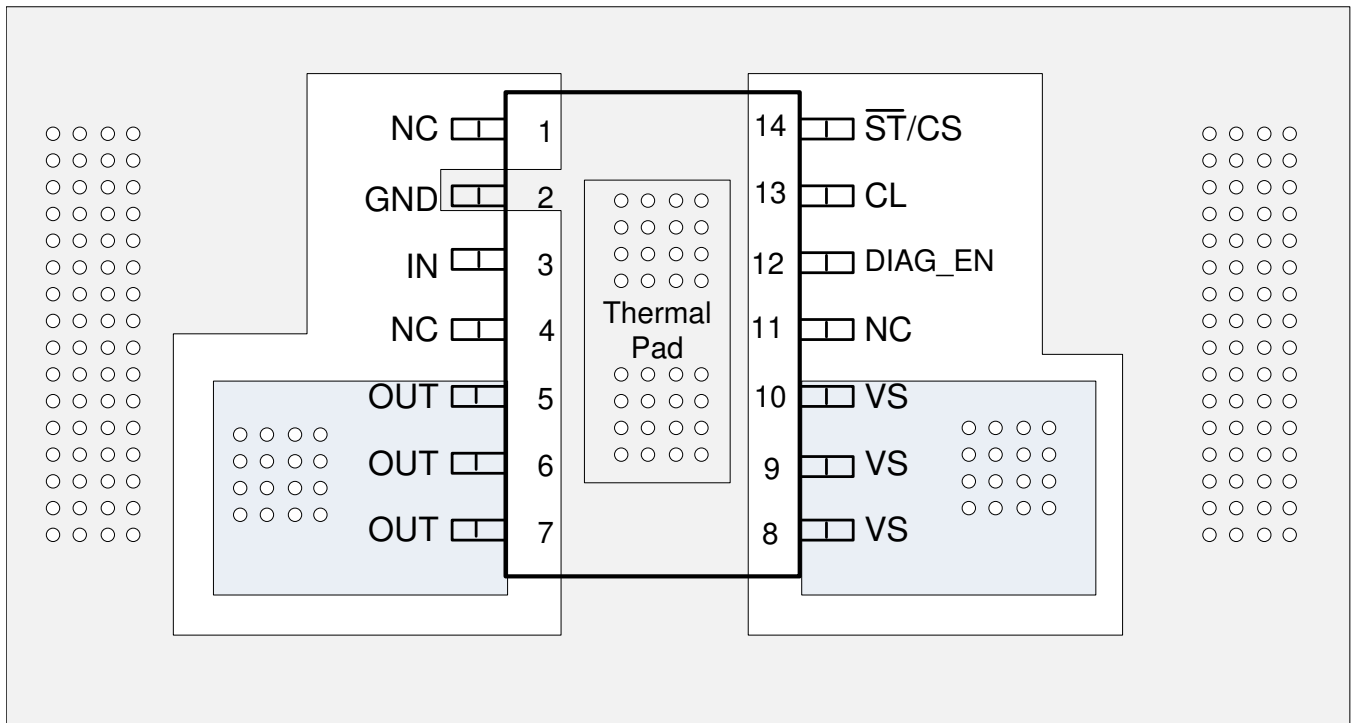

Figure 50. Layout Without a GND Network

Layout Example (continued)

10.2.2 With a GND Network

With a GND network, tie the thermal pad with a single trace through the GND network to the board GND copper.

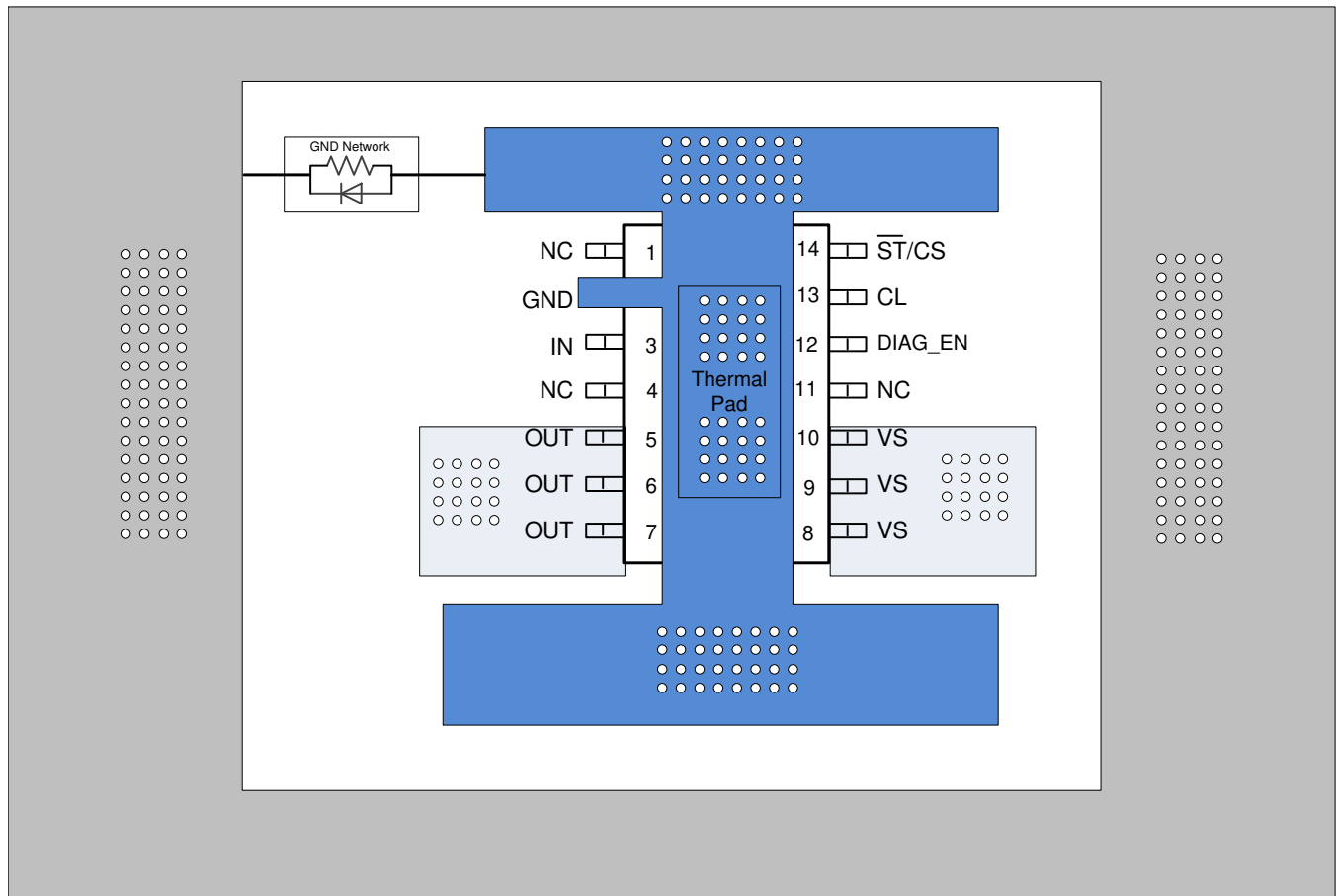

Figure 51. Layout With a GND Network

10.3 Thermal Considerations

This device possesses thermal shutdown (TSD) circuitry as a protection from overheating. For continuous normal operation, the junction temperature should not exceed the thermal-shutdown trip point. If the junction temperature exceeds the thermal-shutdown trip point, the output turns off. When the junction temperature falls below the thermal-shutdown trip point, the output turns on again.

Calculate the power dissipated by the device according to [Equation 13](#).

$$P_T = I_{OUT}^2 \times R_{DS(on)} + V_S \times I_{nom}$$

where

- P_T = Total power dissipation of the device (13)

After determining the power dissipated by the device, calculate the junction temperature from the ambient temperature and the device thermal impedance.

$$T_J = T_A + R_{\theta JA} \times P_T \tag{14}$$

11 器件和文档支持

11.1 接收文档更新通知

要接收文档更新通知，请导航至 TI.com.cn 上的器件产品文件夹。单击右上角的 [通知我](#) 进行注册，即可每周接收产品信息更改摘要。有关更改的详细信息，请查看任何已修订文档中包含的修订历史记录。

11.2 社区资源

[TI E2E™ support forums](#) are an engineer's go-to source for fast, verified answers and design help — straight from the experts. Search existing answers or ask your own question to get the quick design help you need.

Linked content is provided "AS IS" by the respective contributors. They do not constitute TI specifications and do not necessarily reflect TI's views; see TI's [Terms of Use](#).

11.3 商标

E2E is a trademark of Texas Instruments.

All other trademarks are the property of their respective owners.

11.4 静电放电警告



这些装置包含有限的内置 ESD 保护。存储或装卸时，应将导线一起截短或将装置放置于导电泡棉中，以防止 MOS 门极遭受静电损伤。

11.5 Glossary

[SLYZ022](#) — *TI Glossary*.

This glossary lists and explains terms, acronyms, and definitions.

12 机械、封装和可订购信息

以下页面包含机械、封装和可订购信息。这些信息是指定器件的最新可用数据。数据如有变更，恕不另行通知，且不会对此文档进行修订。如需获取此数据表的浏览器版本，请查阅左侧的导航栏。

重要声明和免责声明

TI 均以“原样”提供技术性数据（包括数据表）、设计资源（包括参考设计）、应用或其他设计建议、网络工具、安全信息和其他资源，不保证其中不含任何瑕疵，且不做任何明示或暗示的担保，包括但不限于对适销性、适合某特定用途或不侵犯任何第三方知识产权的暗示担保。

所述资源可供专业开发人员应用TI 产品进行设计使用。您将对以下行为独自承担全部责任：(1) 针对您的应用选择合适的TI 产品；(2) 设计、验证并测试您的应用；(3) 确保您的应用满足相应标准以及任何其他安全、安保或其他要求。所述资源如有变更，恕不另行通知。TI 对您使用所述资源的授权仅限于开发资源所涉及TI 产品的相关应用。除此之外不得复制或展示所述资源，也不提供其它TI 或任何第三方的知识产权授权许可。如因使用所述资源而产生任何索赔、赔偿、成本、损失及债务等，TI 对此概不负责，并且您须赔偿由此对TI 及其代表造成的损害。

TI 所提供产品均受TI 的销售条款 (<http://www.ti.com.cn/zh-cn/legal/termsofsale.html>) 以及ti.com.cn上或随附TI产品提供的其他可适用条款的约束。TI提供所述资源并不扩展或以其他方式更改TI 针对TI 产品所发布的可适用的担保范围或担保免责声明。

邮寄地址：上海市浦东新区世纪大道 1568 号中建大厦 32 楼，邮政编码：200122
Copyright © 2020 德州仪器半导体技术（上海）有限公司

PACKAGING INFORMATION

Orderable Device	Status (1)	Package Type	Package Drawing	Pins	Package Qty	Eco Plan (2)	Lead finish/ Ball material (6)	MSL Peak Temp (3)	Op Temp (°C)	Device Marking (4/5)	Samples
TPS1H100AQPWPRQ1	ACTIVE	HTSSOP	PWP	14	2000	RoHS & Green	NIPDAU	Level-3-260C-168 HR	-40 to 125	1H100AQ	Samples
TPS1H100BQPWPRQ1	ACTIVE	HTSSOP	PWP	14	2000	RoHS & Green	NIPDAU	Level-3-260C-168 HR	-40 to 125	1H100BQ	Samples

(1) The marketing status values are defined as follows:

ACTIVE: Product device recommended for new designs.

LIFEBUY: TI has announced that the device will be discontinued, and a lifetime-buy period is in effect.

NRND: Not recommended for new designs. Device is in production to support existing customers, but TI does not recommend using this part in a new design.

PREVIEW: Device has been announced but is not in production. Samples may or may not be available.

OBSOLETE: TI has discontinued the production of the device.

(2) **RoHS:** TI defines "RoHS" to mean semiconductor products that are compliant with the current EU RoHS requirements for all 10 RoHS substances, including the requirement that RoHS substance do not exceed 0.1% by weight in homogeneous materials. Where designed to be soldered at high temperatures, "RoHS" products are suitable for use in specified lead-free processes. TI may reference these types of products as "Pb-Free".

RoHS Exempt: TI defines "RoHS Exempt" to mean products that contain lead but are compliant with EU RoHS pursuant to a specific EU RoHS exemption.

Green: TI defines "Green" to mean the content of Chlorine (Cl) and Bromine (Br) based flame retardants meet JS709B low halogen requirements of <=1000ppm threshold. Antimony trioxide based flame retardants must also meet the <=1000ppm threshold requirement.

(3) MSL, Peak Temp. - The Moisture Sensitivity Level rating according to the JEDEC industry standard classifications, and peak solder temperature.

(4) There may be additional marking, which relates to the logo, the lot trace code information, or the environmental category on the device.

(5) Multiple Device Markings will be inside parentheses. Only one Device Marking contained in parentheses and separated by a "~" will appear on a device. If a line is indented then it is a continuation of the previous line and the two combined represent the entire Device Marking for that device.

(6) Lead finish/Ball material - Orderable Devices may have multiple material finish options. Finish options are separated by a vertical ruled line. Lead finish/Ball material values may wrap to two lines if the finish value exceeds the maximum column width.

Important Information and Disclaimer:The information provided on this page represents TI's knowledge and belief as of the date that it is provided. TI bases its knowledge and belief on information provided by third parties, and makes no representation or warranty as to the accuracy of such information. Efforts are underway to better integrate information from third parties. TI has taken and continues to take reasonable steps to provide representative and accurate information but may not have conducted destructive testing or chemical analysis on incoming materials and chemicals. TI and TI suppliers consider certain information to be proprietary, and thus CAS numbers and other limited information may not be available for release.

In no event shall TI's liability arising out of such information exceed the total purchase price of the TI part(s) at issue in this document sold by TI to Customer on an annual basis.

TAPE AND REEL INFORMATION

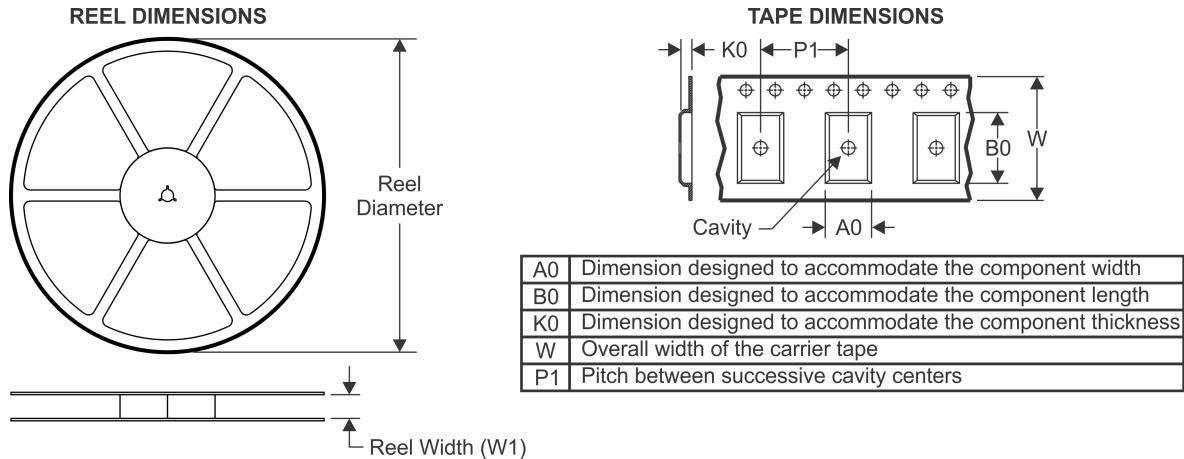

QUADRANT ASSIGNMENTS FOR PIN 1 ORIENTATION IN TAPE



*All dimensions are nominal

Device	Package Type	Package Drawing	Pins	SPQ	Reel Diameter (mm)	Reel Width W1 (mm)	A0 (mm)	B0 (mm)	K0 (mm)	P1 (mm)	W (mm)	Pin1 Quadrant
TPS1H100AQPWPRQ1	HTSSOP	PWP	14	2000	330.0	12.4	6.9	5.6	1.6	8.0	12.0	Q1
TPS1H100BQPWPRQ1	HTSSOP	PWP	14	2000	330.0	12.4	6.9	5.6	1.6	8.0	12.0	Q1

TAPE AND REEL BOX DIMENSIONS

*All dimensions are nominal

Device	Package Type	Package Drawing	Pins	SPQ	Length (mm)	Width (mm)	Height (mm)
TPS1H100AQPWRQ1	HTSSOP	PWP	14	2000	350.0	350.0	43.0
TPS1H100BQPWRQ1	HTSSOP	PWP	14	2000	350.0	350.0	43.0

PWP (R-PDSO-G14)

PowerPAD™ PLASTIC SMALL OUTLINE

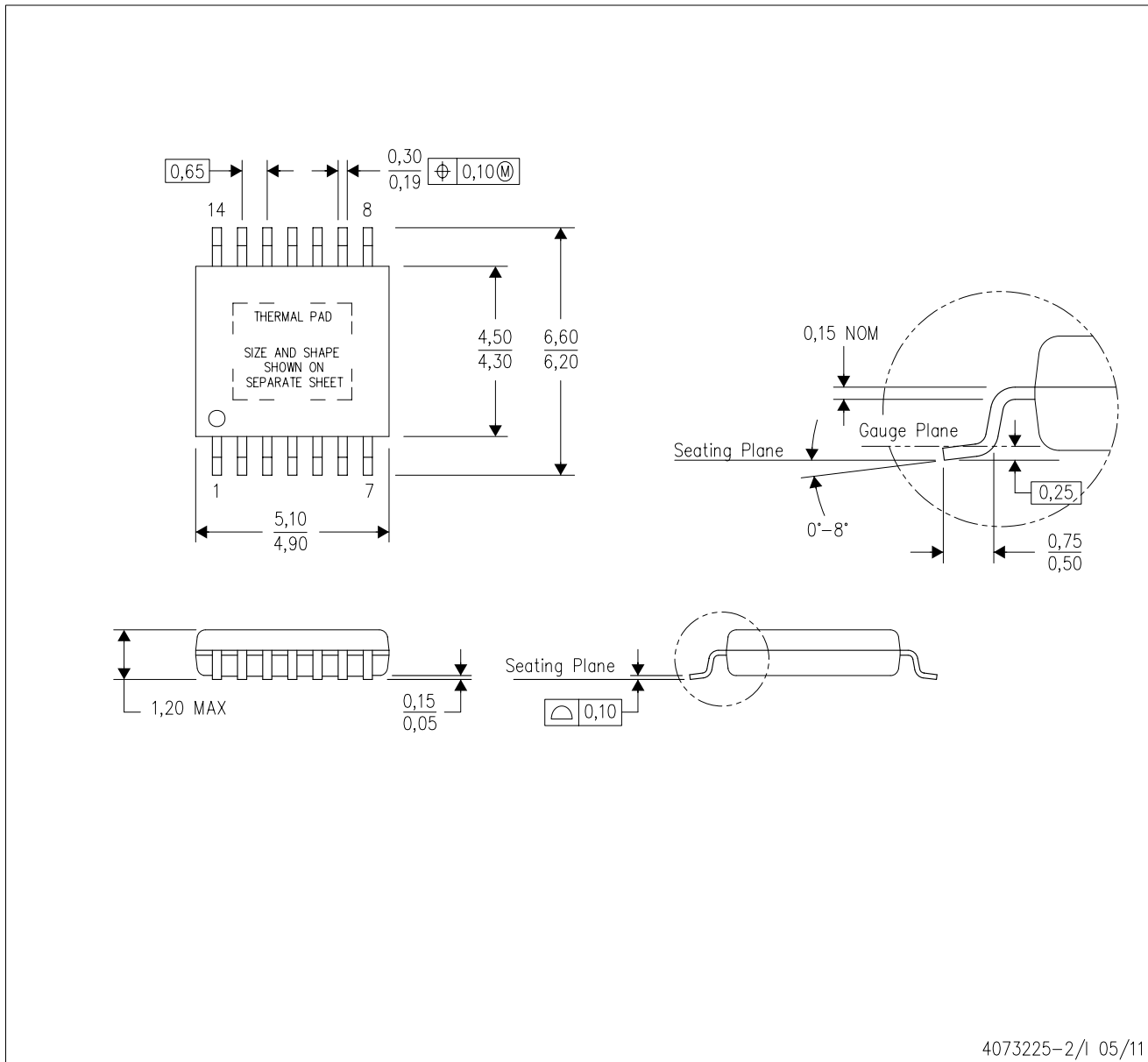

4073225-2/1 05/11

- NOTES:
- All linear dimensions are in millimeters.
 - This drawing is subject to change without notice.
 - Body dimensions do not include mold flash or protrusions. Mold flash and protrusion shall not exceed 0.15 per side.
 - This package is designed to be soldered to a thermal pad on the board. Refer to Technical Brief, PowerPad Thermally Enhanced Package, Texas Instruments Literature No. SLMA002 for information regarding recommended board layout. This document is available at www.ti.com <<http://www.ti.com>>.
 - See the additional figure in the Product Data Sheet for details regarding the exposed thermal pad features and dimensions.
 - Falls within JEDEC MO-153

PowerPAD is a trademark of Texas Instruments.

THERMAL PAD MECHANICAL DATA

PWP (R-PDSO-G14)

PowerPAD™ SMALL PLASTIC OUTLINE

THERMAL INFORMATION

This PowerPAD™ package incorporates an exposed thermal pad that is designed to be attached to a printed circuit board (PCB). The thermal pad must be soldered directly to the PCB. After soldering, the PCB can be used as a heatsink. In addition, through the use of thermal vias, the thermal pad can be attached directly to the appropriate copper plane shown in the electrical schematic for the device, or alternatively, can be attached to a special heatsink structure designed into the PCB. This design optimizes the heat transfer from the integrated circuit (IC).

For additional information on the PowerPAD package and how to take advantage of its heat dissipating abilities, refer to Technical Brief, PowerPAD Thermally Enhanced Package, Texas Instruments Literature No. SLMA002 and Application Brief, PowerPAD Made Easy, Texas Instruments Literature No. SLMA004. Both documents are available at www.ti.com.

The exposed thermal pad dimensions for this package are shown in the following illustration.

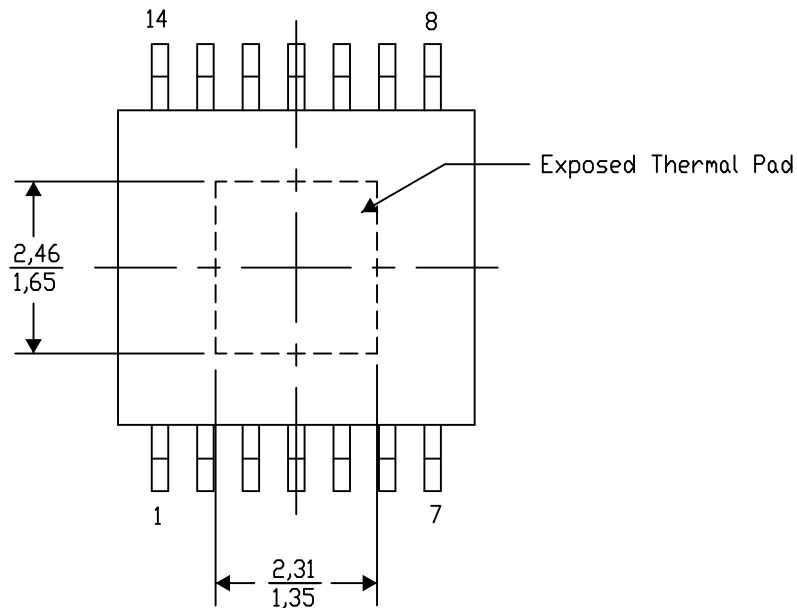

Top View

Exposed Thermal Pad Dimensions

4206332-2/AO 01/16

NOTE: A. All linear dimensions are in millimeters

PowerPAD is a trademark of Texas Instruments

PWP (R-PDSO-G14)

PowerPAD™ PLASTIC SMALL OUTLINE

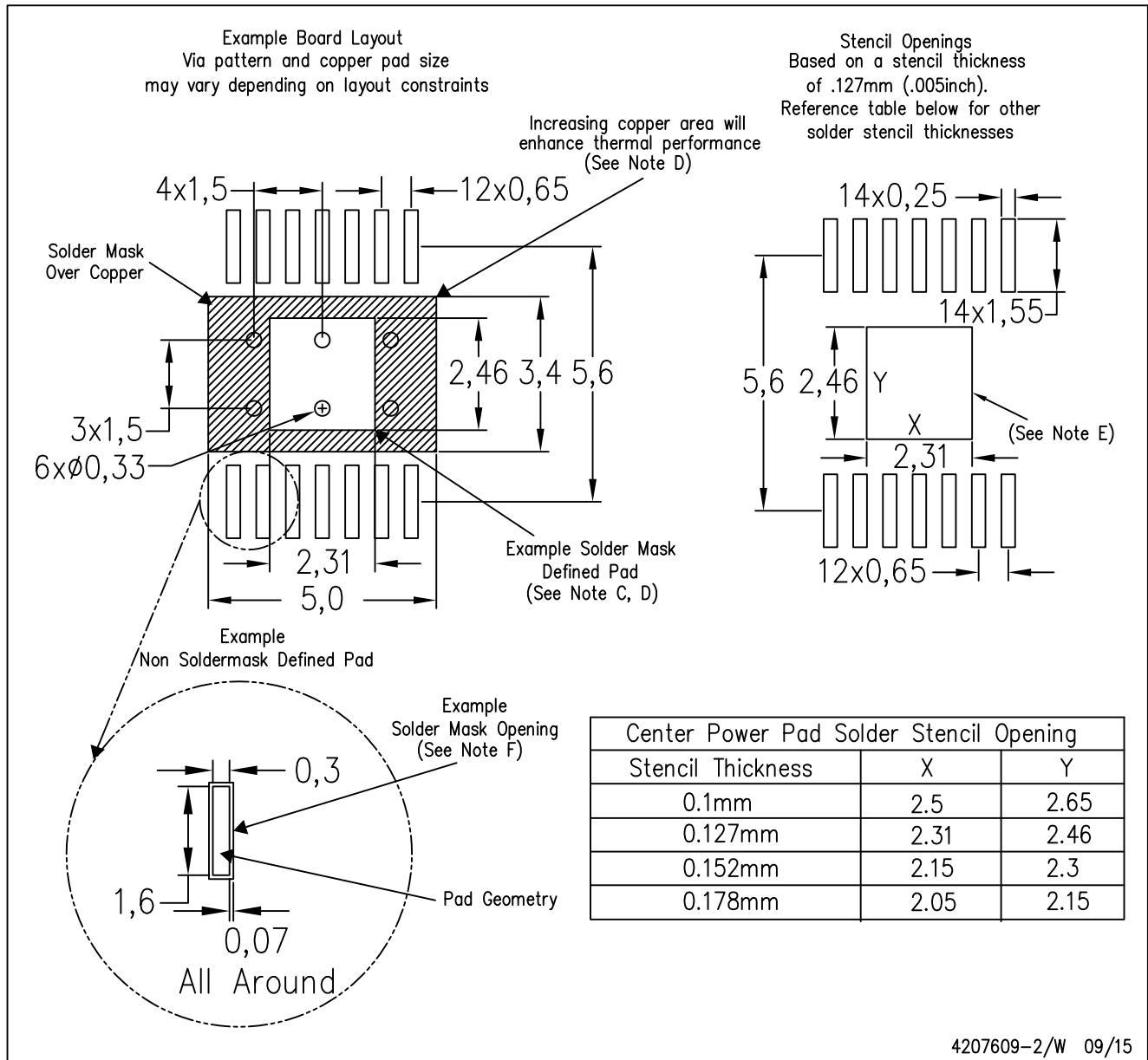

- NOTES:
- A. All linear dimensions are in millimeters.
 - B. This drawing is subject to change without notice.
 - C. Customers should place a note on the circuit board fabrication drawing not to alter the center solder mask defined pad.
 - D. This package is designed to be soldered to a thermal pad on the board. Refer to Technical Brief, PowerPAD Thermally Enhanced Package, Texas Instruments Literature No. SLMA002, SLMA004, and also the Product Data Sheets for specific thermal information, via requirements, and recommended board layout. These documents are available at www.ti.com <<http://www.ti.com>>. Publication IPC-7351 is recommended for alternate designs.
 - E. Laser cutting apertures with trapezoidal walls and also rounding corners will offer better paste release. Customers should contact their board assembly site for stencil design recommendations. Example stencil design based on a 50% volumetric metal load solder paste. Refer to IPC-7525 for other stencil recommendations.
 - F. Customers should contact their board fabrication site for solder mask tolerances between and around signal pads.

重要声明和免责声明

TI 均以“原样”提供技术性及其可靠性数据（包括数据表）、设计资源（包括参考设计）、应用或其他设计建议、网络工具、安全信息和其他资源，不保证其中不含任何瑕疵，且不做任何明示或暗示的担保，包括但不限于对适销性、适合某特定用途或不侵犯任何第三方知识产权的暗示担保。

所述资源可供专业开发人员应用TI 产品进行设计使用。您将对以下行为独自承担全部责任：(1) 针对您的应用选择合适的TI 产品；(2) 设计、验证并测试您的应用；(3) 确保您的应用满足相应标准以及任何其他安全、安保或其他要求。所述资源如有变更，恕不另行通知。TI 对您使用所述资源的授权仅限于开发资源所涉及TI 产品的相关应用。除此之外不得复制或展示所述资源，也不提供其它TI 或任何第三方的知识产权授权许可。如因使用所述资源而产生任何索赔、赔偿、成本、损失及债务等，TI 对此概不负责，并且您须赔偿由此对TI 及其代表造成的损害。

TI 所提供产品均受TI 的销售条款 (<http://www.ti.com.cn/zh-cn/legal/termsofsale.html>) 以及ti.com.cn上或随附TI产品提供的其他可适用条款的约束。TI提供所述资源并不扩展或以其他方式更改TI 针对TI 产品所发布的可适用的担保范围或担保免责声明。

邮寄地址：上海市浦东新区世纪大道 1568 号中建大厦 32 楼，邮政编码：200122

Copyright © 2020 德州仪器半导体技术（上海）有限公司