

TPD4E02B04-Q1 4-Channel ESD Protection Diode for USB Type-C and HDMI 2.0

1 Features

- AEC-Q101 Qualified
- IEC 61000-4-2 Level 4 ESD Protection
 - ±12-kV Contact Discharge
 - ±15-kV Air Gap Discharge
- ISO 10605 (330 pF, 330 Ω) ESD Protection
 - ±10 kV Contact Discharge
 - ±10-kV Air Gap Discharge
- IEC 61000-4-4 EFT Protection
 - 80 A (5/50 ns)
- IEC 61000-4-5 Surge Protection
 - 2 A (8/20 μs)
- IO Capacitance:
 - 0.25 pF (Typical)
- DC Breakdown Voltage: 5.5 V (Minimum)
- Ultra Low Leakage Current: 10 nA (Maximum)
- Low ESD Clamping Voltage: 8.8 V at 5-A TLP
- Supports High Speed Interfaces up to 10 Gbps
- Industrial Temperature Range: –40°C to +125°C
- Easy Flow-Through Routing Package

2 Applications

- End Equipment
 - Head Unit
 - Rear Seat Entertainment
 - Telematics
 - USB Hub
 - Cluster
 - Body Control Module
 - Media Interface
- Interfaces
 - USB Type-C
 - USB 3.1 Gen 2
 - HDMI 2.0/1.4
 - USB 3.0
 - DisplayPort 1.3
 - 10/100/1000 Mbps Ethernet

3 Description

The TPD4E02B04-Q1 is an automotive-qualified bidirectional TVS ESD protection diode array for USB Type-C and HDMI 2.0 circuit protection. The TPD4E02B04-Q1 is rated to dissipate ESD strikes up to 10 kV per ISO 10605 (330 pF, 330 Ω) ESD standard. The TPD4E02B04 is also rated to dissipate ESD strikes at the maximum level specified in the IEC 61000-4-2 international standard (Level 4).

This device features a 0.25-pF IO capacitance per channel making it ideal for protecting high-speed interfaces up to 10 Gbps such as USB 3.1 Gen2. The low dynamic resistance and low clamping voltage ensure system level protection against transient events.

The TPD4E02B04-Q1 is offered in the industry standard USON-10 (DQA) package. The package features flow-through routing and 0.5-mm pin pitch easing implementation and reducing design time.

This device is also available without automotive qualification: [TPD4E02B04](#).

Device Information⁽¹⁾

PART NUMBER	PACKAGE	BODY SIZE (NOM)
TPD4E02B04-Q1	USON (10)	2.50 mm x 1.00 mm

(1) For all available packages, see the orderable addendum at the end of the data sheet.

Typical Application Schematic

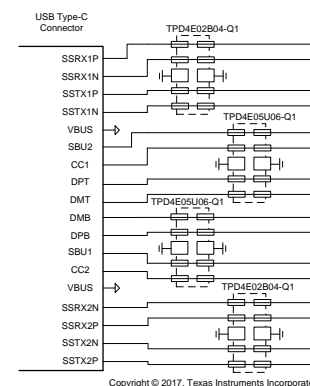

Table of Contents

1 Features	1	7.3 Feature Description	10
2 Applications	1	7.4 Device Functional Modes	11
3 Description	1	8 Application and Implementation	12
4 Revision History	2	8.1 Application Information	12
5 Pin Configuration and Functions	3	8.2 Typical Application	12
6 Specifications	4	9 Power Supply Recommendations	15
6.1 Absolute Maximum Ratings	4	10 Layout	15
6.2 ESD Ratings—AEC Specification	4	10.1 Layout Guidelines	15
6.3 ESD Ratings—IEC Specification	4	10.2 Layout Examples	15
6.4 ESD Ratings—ISO Specification	4	11 Device and Documentation Support	17
6.5 Recommended Operating Conditions	4	11.1 Documentation Support	17
6.6 Thermal Information	4	11.2 Receiving Notification of Documentation Updates	17
6.7 Electrical Characteristics	5	11.3 Community Resources	17
6.8 Typical Characteristics	6	11.4 Trademarks	17
7 Detailed Description	10	11.5 Electrostatic Discharge Caution	17
7.1 Overview	10	11.6 Glossary	17
7.2 Functional Block Diagram	10	12 Mechanical, Packaging, and Orderable Information	17

4 Revision History

Changes from Original (June 2017) to Revision A	Page
• First public release of data sheet	1
• Changed ISO airgap rating to 10 kV	1
• Changed Contact rating to 10 kV	1
• Changed Interfaces Ethernet to 10/100/1000 Mbps	1

5 Pin Configuration and Functions

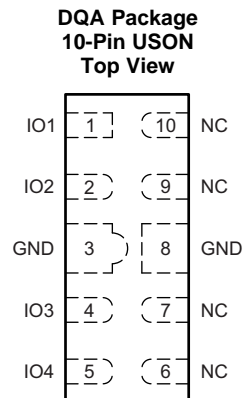

Pin Functions

PIN		TYPE	DESCRIPTION
NAME	NO.		
GND	3	Ground	Ground. Connect to ground
GND	8		
IO1	1	I/O	ESD protected channel
IO2	2		
IO3	4		
IO4	5		
NC	6	NC	Not connected; Used for optional straight-through routing. Can be left floating or grounded
NC	7		
NC	9		
NC	10		

6 Specifications

6.1 Absolute Maximum Ratings

over operating free-air temperature range (unless otherwise noted)⁽¹⁾

		MIN	MAX	UNIT
Electrical fast transient	IEC 61000-4-5 (5/50 ns) at 25°C		80	A
Peak pulse	IEC 61000-4-5 power ($t_p - 8/20 \mu\text{s}$) at 25°C		17	W
	IEC 61000-4-5 Ccurrent ($t_p - 8/20 \mu\text{s}$) at 25°C		2	A
T_A	Operating free-air temperature	-40	125	°C
T_{stg}	Storage temperature	-65	155	°C

(1) Stresses beyond those listed under *Absolute Maximum Ratings* may cause permanent damage to the device. These are stress ratings only, which do not imply functional operation of the device at these or any other conditions beyond those indicated under *Recommended Operating Conditions*. Exposure to absolute-maximum-rated conditions for extended periods may affect device reliability.

6.2 ESD Ratings—AEC Specification

		VALUE	UNIT
$V_{\text{(ESD)}}$	Electrostatic discharge	Human-body model (HBM), per AEC Q100-002 ⁽¹⁾	±2500
		Charged-device model (CDM), per AEC Q100-011	±1000

(1) AEC Q100-002 indicates that HBM stressing shall be in accordance with the ANSI/ESDA/JEDEC JS-001 specification.

6.3 ESD Ratings—IEC Specification

		VALUE	UNIT
$V_{\text{(ESD)}}$	Electrostatic discharge	IEC 61000-4-2 contact discharge	±12000
		IEC 61000-4-2 air-gap discharge	±15000

6.4 ESD Ratings—ISO Specification

		VALUE	UNIT
$V_{\text{(ESD)}}$	Electrostatic discharge	ISO 10605 330 pF, 330 Ω , IO	±10000
		Contact discharge	±10000
		Air-gap discharge	±10000

6.5 Recommended Operating Conditions

over operating free-air temperature range (unless otherwise noted)

		MIN	MAX	UNIT
V_{IO}	Input pin voltage	-3.6	3.6	V
T_A	Operating free-air temperature	-40	125	°C

6.6 Thermal Information

THERMAL METRIC ⁽¹⁾		TPD4E02B04-Q1	UNIT
		DQA (USON)	
		10 PINS	
$R_{\theta\text{JA}}$	Junction-to-ambient thermal resistance	348.7	°C/W
$R_{\theta\text{JC(top)}}$	Junction-to-case (top) thermal resistance	214.1	°C/W
$R_{\theta\text{JB}}$	Junction-to-board thermal resistance	270.7	°C/W
Ψ_{JT}	Junction-to-top characterization parameter	81.7	°C/W
Ψ_{JB}	Junction-to-board characterization parameter	270.7	°C/W
$R_{\theta\text{JC(bot)}}$	Junction-to-case (bottom) thermal resistance	N/A	°C/W

(1) For more information about traditional and new thermal metrics, see the [Semiconductor and IC Package Thermal Metrics](#) application report.

6.7 Electrical Characteristics

over operating free-air temperature range (unless otherwise noted)

PARAMETER		TEST CONDITIONS	MIN	TYP	MAX	UNIT
V_{RWM}	Reverse stand-off voltage	$I_{IO} < 10 \text{ nA}$	-3.6		3.6	V
V_{BRF}	Breakdown voltage, any IO pin to GND ⁽¹⁾	$I_{IO} = 1 \text{ mA}, T_A = 25^\circ\text{C}$	5.5	6.4	7.5	V
V_{BRR}	Breakdown voltage, GND to any IO pin ⁽¹⁾	$I_{IO} = 1 \text{ mA}, T_A = 25^\circ\text{C}$	-5.5	-6.4	-7.5	V
V_{HOLD}	Holding voltage ⁽²⁾	$I_{IO} = 1 \text{ mA}$		5.8		V
V_{CLAMP}	Clamping voltage	$I_{PP} = 1 \text{ A}, \text{TLP, from IO to GND}$		6.6		V
		$I_{PP} = 5 \text{ A}, \text{TLP, from IO to GND}$		8.8		
		$I_{PP} = 1 \text{ A}, \text{TLP, from GND to IO}$		6.6		
		$I_{PP} = 5 \text{ A}, \text{TLP, from GND to IO}$		8.8		
I_{LEAK}	Leakage current, any IO to GND	$V_{IO} = \pm 2.5 \text{ V}$			10	nA
R_{DYN}	Dynamic resistance	IO to GND		0.47		Ω
		GND to IO		0.47		
C_L	Line capacitance	$V_{IO} = 0 \text{ V}, f = 1 \text{ MHz}, \text{IO to GND}, T_A = 25^\circ\text{C}$		0.25	0.33	pF
ΔC_L	Variation of line capacitance	Delta of capacitance between any two IO pins, $V_{IO} = 0 \text{ V}, f = 1 \text{ MHz}, T_A = 25^\circ\text{C}, \text{GND} = 0 \text{ V}$		0.01	0.07	pF
C_{CROSS}	Channel to channel capacitance	Capacitance from one IO to another, $V_{IO} = 0 \text{ V}, f = 1 \text{ MHz}, \text{GND} = 0 \text{ V}$		0.13	0.16	pF

(1) V_{BRF} and V_{BRR} are defined as the voltage when 1 mA is applied in the positive-going direction, before the device latches into the snapback state.

(2) V_{HOLD} is defined as the voltage when 1 mA is applied in the negative-going direction, after the device has successfully latched into the snapback state.

6.8 Typical Characteristics

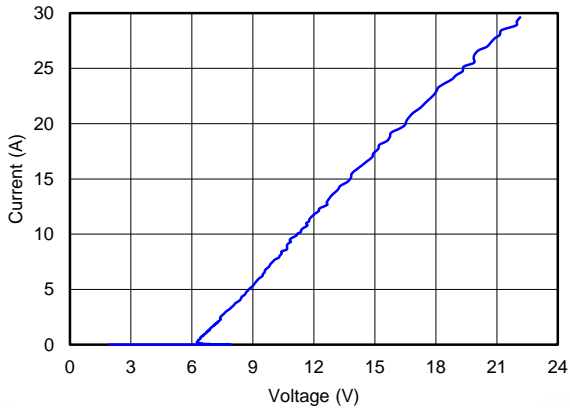

Figure 1. Positive TLP Curve

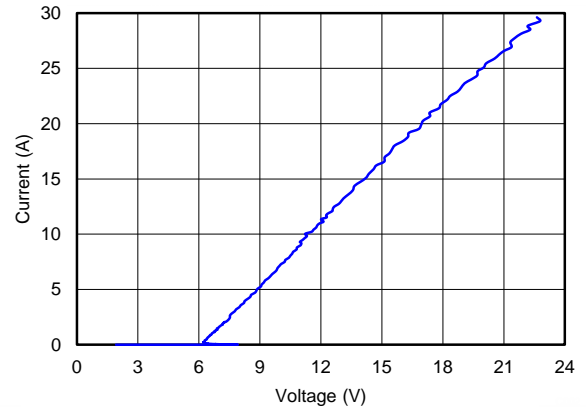

Figure 2. Negative TLP Curve

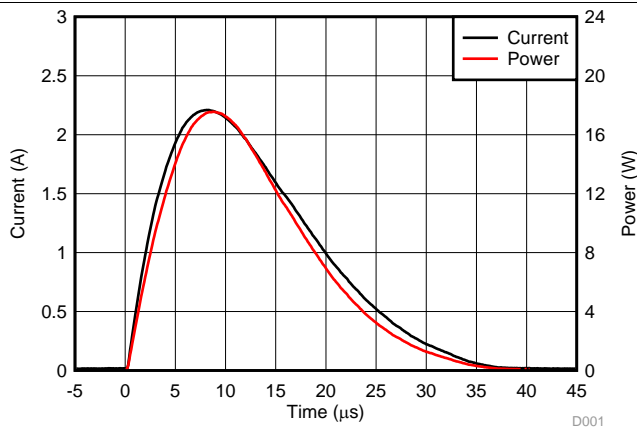

Figure 3. Surge Curve ($t_p = 8/20 \mu s$), any IO pin to GND

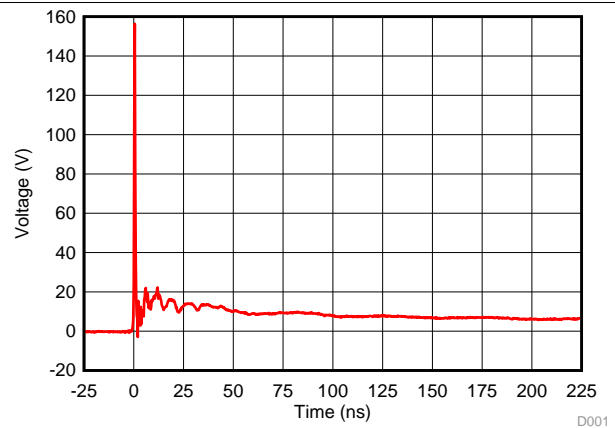

Figure 4. 8-kV IEC Waveform

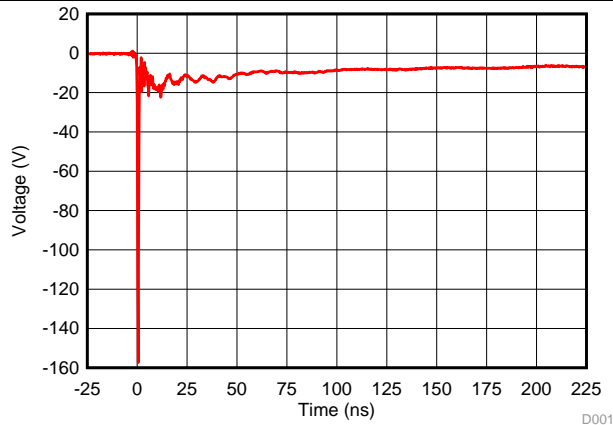

Figure 5. -8-kV IEC Waveform

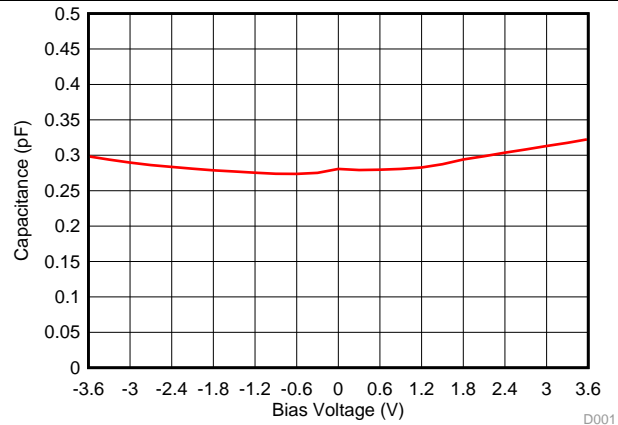
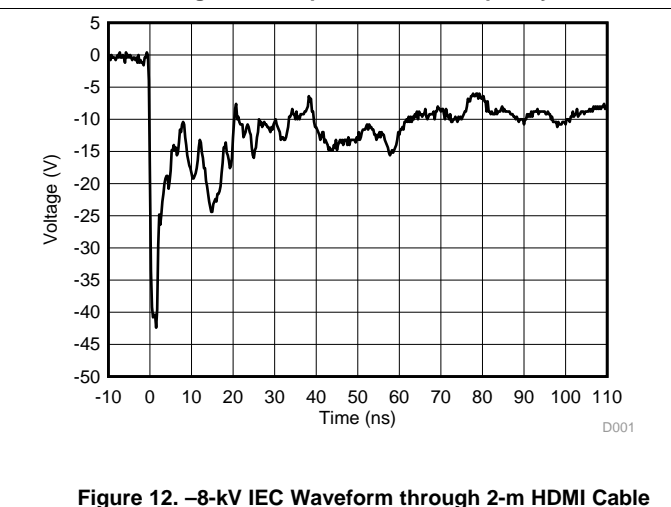
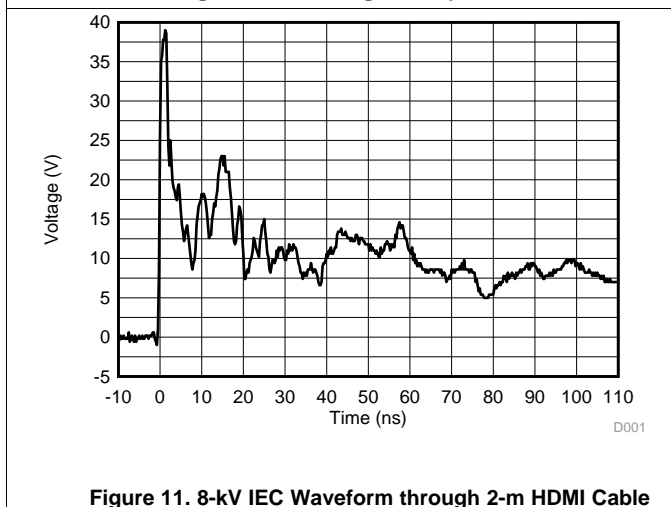
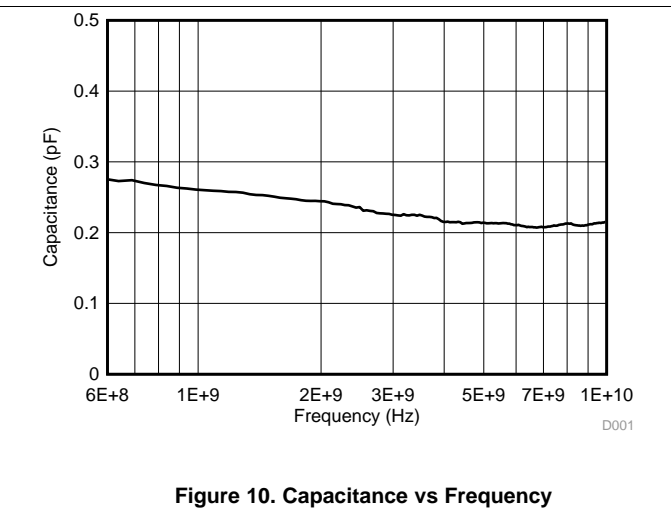
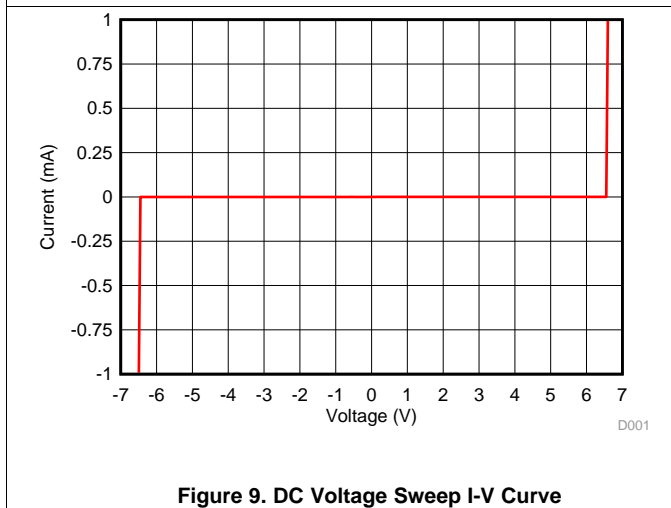
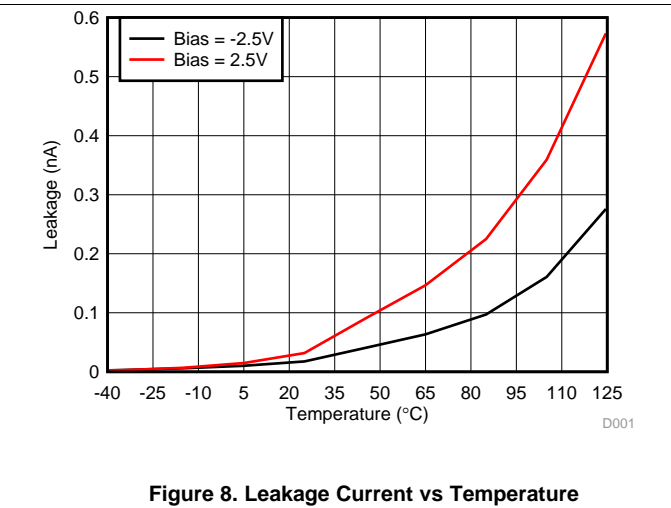
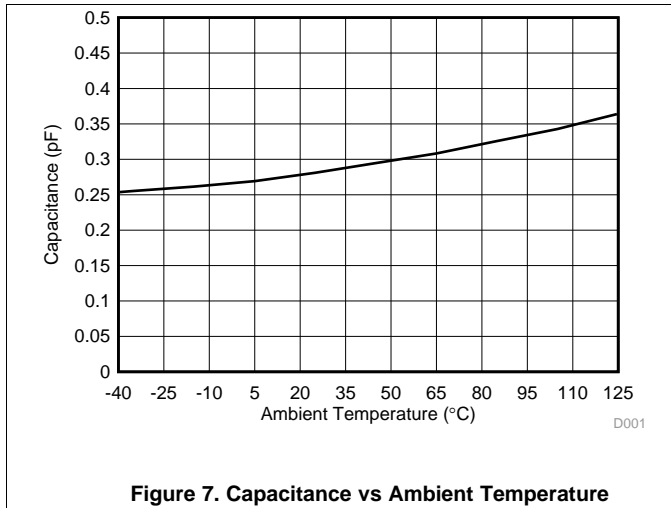

Figure 6. Capacitance vs Bias Voltage

Typical Characteristics (continued)



Typical Characteristics (continued)

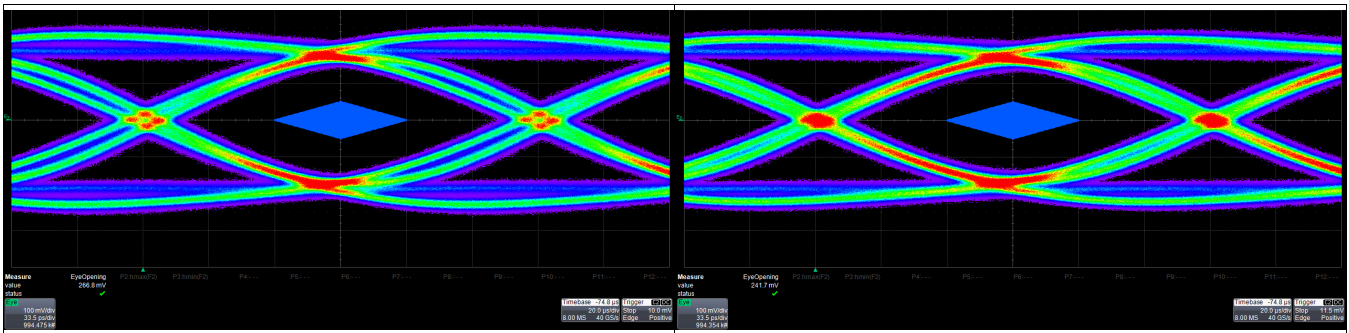

Figure 13. USB3.0 Eye Diagram (Bare Board)

Figure 14. USB3.0 Eye Diagram (With TPD4E02B04-Q1)

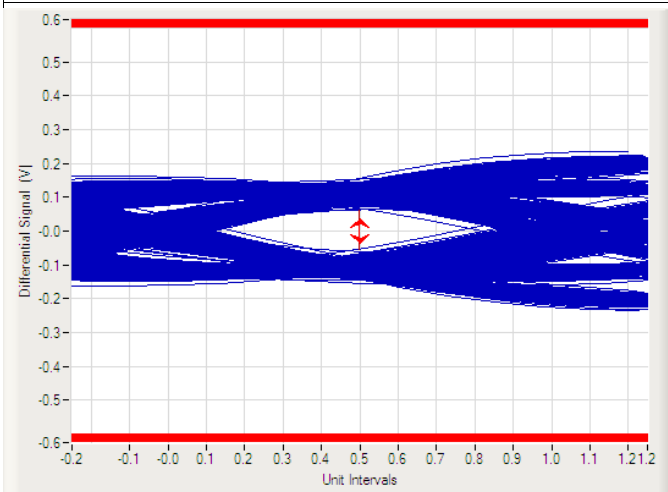

Figure 15. USB3.1 Gen 2 Eye Diagram (Bare Board)

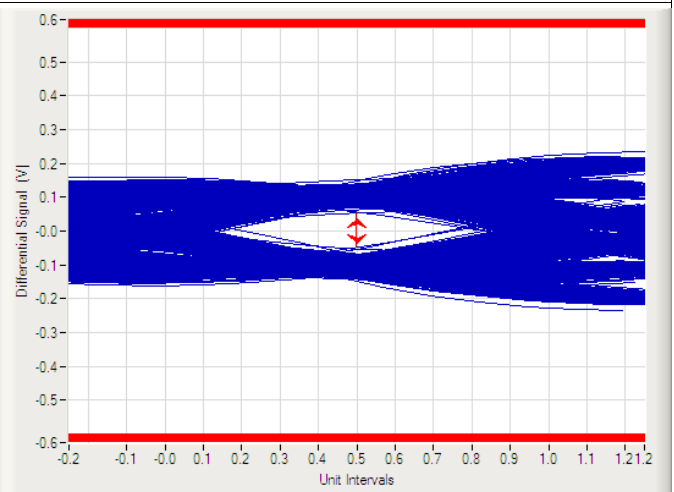

Figure 16. USB3.1 Gen 2 Eye Diagram (With TPD4E02B04-Q1)

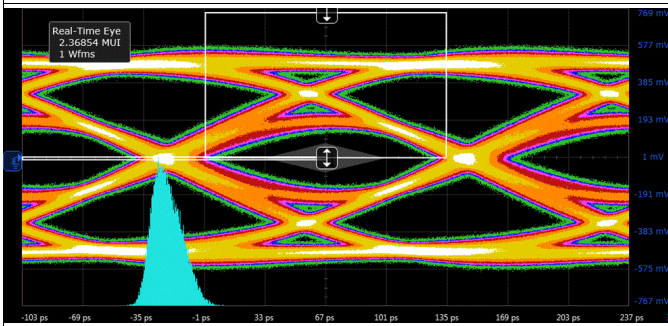

Figure 17. HDMI2.0 6-Gbps TP2 Eye Diagram (Bare Board)

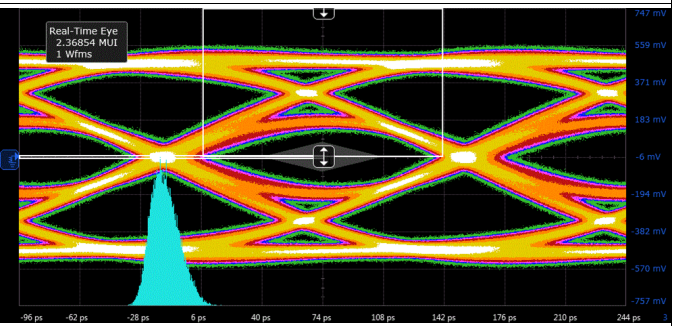

Figure 18. HDMI2.0 6-Gbps TP2 Eye Diagram (With TPD4E02B04-Q1)

Typical Characteristics (continued)

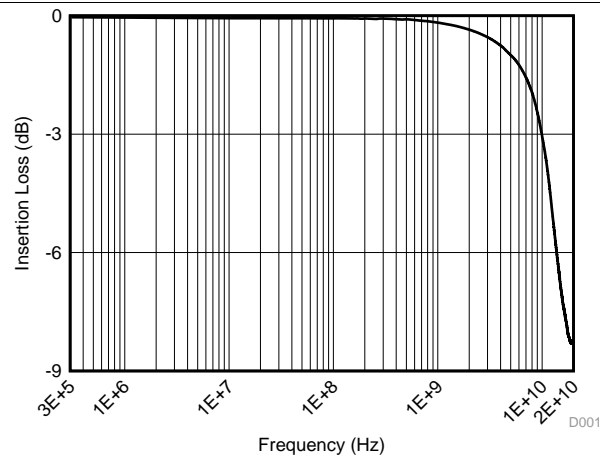

Figure 19. Differential Insertion Loss

7 Detailed Description

7.1 Overview

The TPD4E02B04-Q1 is an automotive-qualified bidirectional ESD Protection Diode with ultra-low capacitance. This device can dissipate ESD strikes above the maximum level specified by the IEC 61000-4-2 (Level 4) International Standard. The ultra-low capacitance makes this device ideal for protecting any super high-speed signal pins.

7.2 Functional Block Diagram

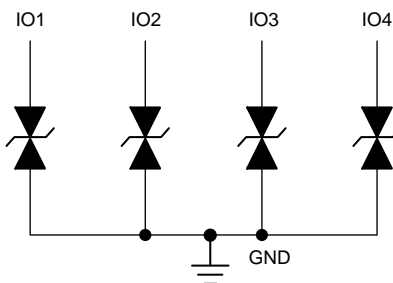

7.3 Feature Description

7.3.1 AEC-Q101 Qualified

This device is qualified to AEC-Q101 standards and is qualified to operate from -40°C to $+125^{\circ}\text{C}$.

7.3.2 ISO 10605 ESD Protection

The I/O pins can withstand ESD events of at least $\pm 10\text{-kV}$ contact and $\pm 10\text{-kV}$ air gap according to the ISO 10605 (330 pF, 330 Ω) standard. The device diverts the current to ground.

7.3.3 IEC 61000-4-2 ESD Protection

The I/O pins can withstand ESD events up to $\pm 12\text{-kV}$ contact and $\pm 15\text{-kV}$ air gap. An ESD-surge clamp diverts the current to ground.

7.3.4 IEC 61000-4-4 EFT Protection

The I/O pins can withstand an electrical fast transient burst of up to 80 A (5/50 ns waveform, 4 kV with 50- Ω impedance). An ESD-surge clamp diverts the current to ground.

7.3.5 IEC 61000-4-5 Surge Protection

The I/O pins can withstand surge events up to 2 A and 17 W (8/20 μs waveform). An ESD-surge clamp diverts this current to ground.

7.3.6 IO Capacitance

The capacitance between each I/O pin to ground is 0.25 pF (typical). This device supports data rates up to 10 Gbps.

7.3.7 DC Breakdown Voltage

The DC breakdown voltage of each I/O pin is a minimum of $\pm 5.5\text{ V}$. This ensures that sensitive equipment is protected from surges above the reverse standoff voltage of $\pm 3.6\text{ V}$.

7.3.8 Ultra Low Leakage Current

The I/O pins feature an ultra-low leakage current of 10 nA (maximum) with a bias of $\pm 2.5\text{ V}$.

Feature Description (continued)

7.3.9 Low ESD Clamping Voltage

The I/O pins feature an ESD clamp that is capable of clamping the voltage to 8.8 V ($I_{PP} = 5$ A).

7.3.10 Supports High Speed Interfaces

This device is capable of supporting high speed interfaces up to 10 Gbps, because of the extremely low IO capacitance.

7.3.11 Industrial Temperature Range

This device features an industrial operating range of -40°C to $+125^{\circ}\text{C}$.

7.3.12 Easy Flow-Through Routing Package

The layout of this device makes it simple and easy to add protection to an existing layout. The packages offers flow-through routing, requiring minimal modification to an existing layout.

7.4 Device Functional Modes

The TPD4E02B04-Q1 is a passive integrated circuit that triggers when voltages are above V_{BRF} or below V_{BRR} . During ESD events, voltages as high as ± 15 kV (air) can be directed to ground via the internal diode network. When the voltages on the protected line fall below the trigger levels of the TPD4E02B04-Q1 (usually within 10s of nano-seconds) the device reverts to passive.

8 Application and Implementation

NOTE

Information in the following applications sections is not part of the TI component specification, and TI does not warrant its accuracy or completeness. TI's customers are responsible for determining suitability of components for their purposes. Customers should validate and test their design implementation to confirm system functionality.

8.1 Application Information

The TPD4E02B04-Q1 is a diode type TVS which is used to provide a path to ground for dissipating ESD events on high-speed signal lines between a human interface connector and a system. As the current from ESD passes through the TVS, only a small voltage drop is present across the diode. This is the voltage presented to the protected IC. The low R_{DYN} of the triggered TVS holds this voltage, V_{CLAMP} , to a safe level for the protected IC.

8.2 Typical Application

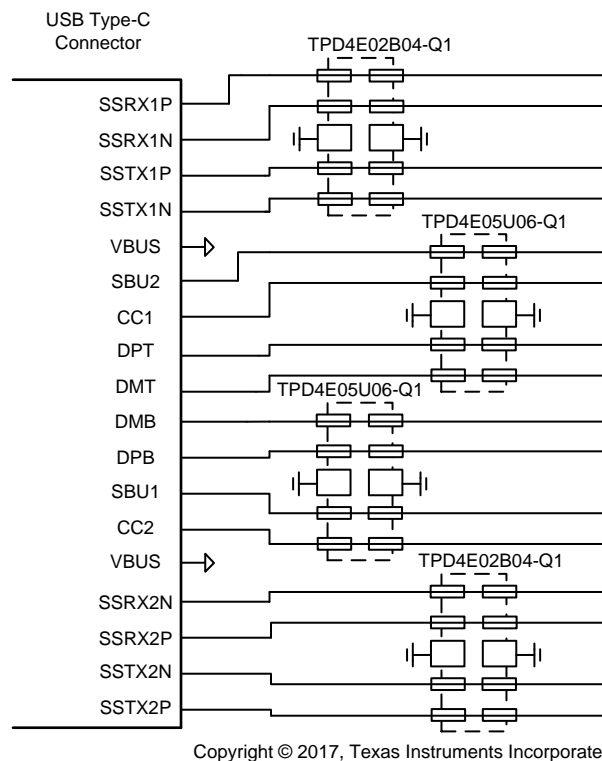

Figure 20. USB 3.1 Gen 2 Type-C ESD Schematic

Typical Application (continued)

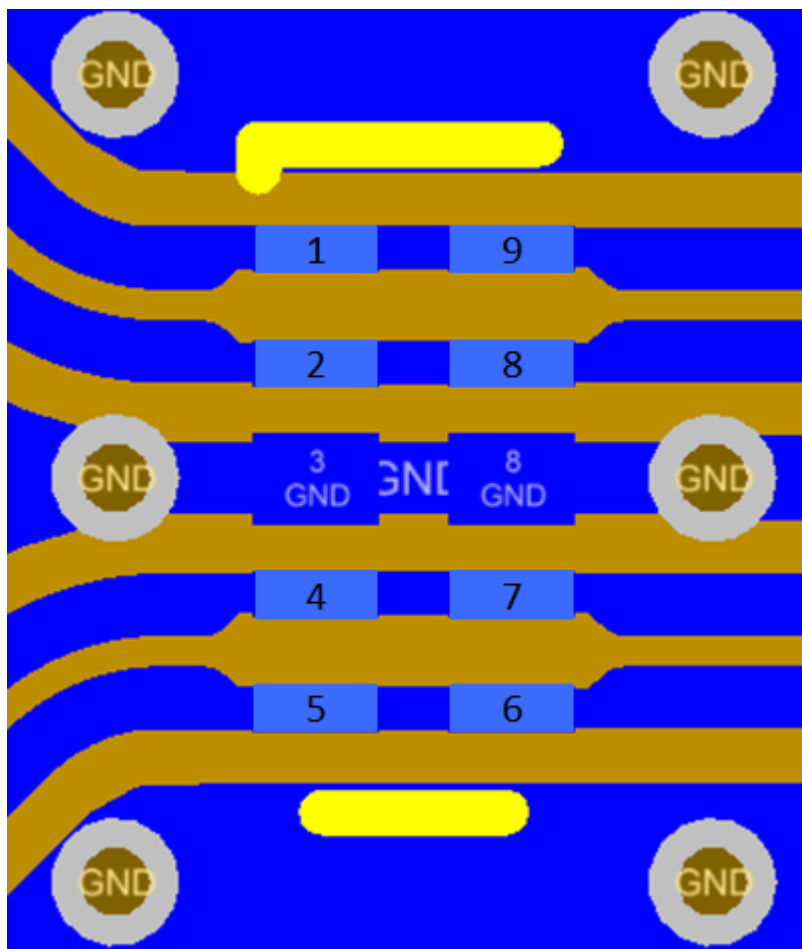

Figure 21. USB 3.1 Gen 2 SuperSpeed Layout

8.2.1 Design Requirements

For this design example two TPD4E02B04-Q1 devices and two TPD4E05U06 devices are being used in a USB 3.1 Gen 2 Type-C application. This provides a complete ESD protection scheme.

Given the USB 3.1 Gen 2 Type-C application, the parameters listed in Table 1 are known.

Table 1. Design Parameters

DESIGN PARAMETER	VALUE
Signal Range on SuperSpeed+ Lines	0 V to 3.6 V
Operating Frequency on SuperSpeed+ Lines	5 GHz
Signal Range on CC, SBU, and DP/DM Lines	0 V to 5 V
Operating Frequency on CC, SBU, and DP/DM Lines	up to 480 MHz

8.2.2 Detailed Design Procedure

8.2.2.1 Signal Range

The TPD4E02B04-Q1 supports signal ranges between -3.6 V and 3.6 V, which supports the SuperSpeed+ pairs on the USB Type-C application. The TPD4E05U06 supports signal ranges between 0 V and 5.5 V, which supports the CC, SBU, and DP/DM lines.

8.2.2.2 Operating Frequency

The TPD4E02B04-Q1 has a 0.25 pF (typical) capacitance, which supports the USB3.1 Gen 2 data rates of 10 Gbps. The TPD4E05U06 has a 0.5 pF (typical) capacitance, which easily supports the CC, SBU, and DP/DM data rates.

8.2.3 Application Curves

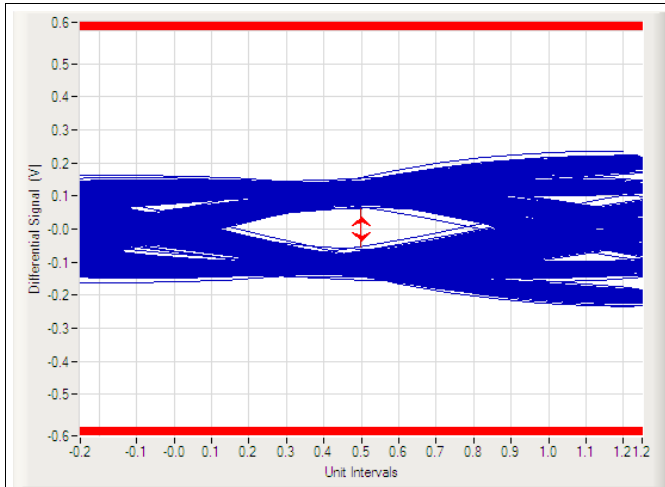

Figure 22. USB 3.1 Gen 2 10-Gbps Eye Diagram (Bare Board)

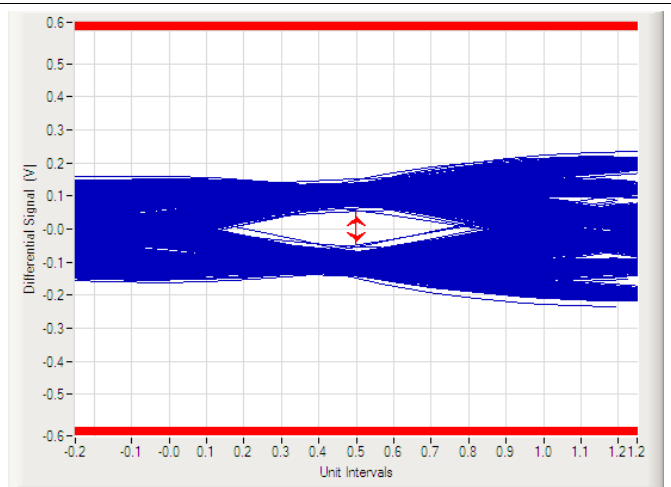

Figure 23. USB 3.1 Gen 2 10-Gbps Eye Diagram (With TPD4E02B04-Q1)

9 Power Supply Recommendations

This device is a passive ESD device so there is no need to power it. Take care not to violate the recommended I/O specification (–3.6 V to 3.6 V) to ensure the device functions properly.

10 Layout

10.1 Layout Guidelines

- The optimum placement is as close to the connector as possible.
 - EMI during an ESD event can couple from the trace being struck to other nearby unprotected traces, resulting in early system failures.
 - The PCB designer must minimize the possibility of EMI coupling by keeping any unprotected traces away from the protected traces which are between the TVS and the connector.
- Route the protected traces as straight as possible.
- Eliminate any sharp corners on the protected traces between the TVS and the connector by using rounded corners with the largest radii possible.
 - Electric fields tend to build up on corners, increasing EMI coupling.

10.2 Layout Examples

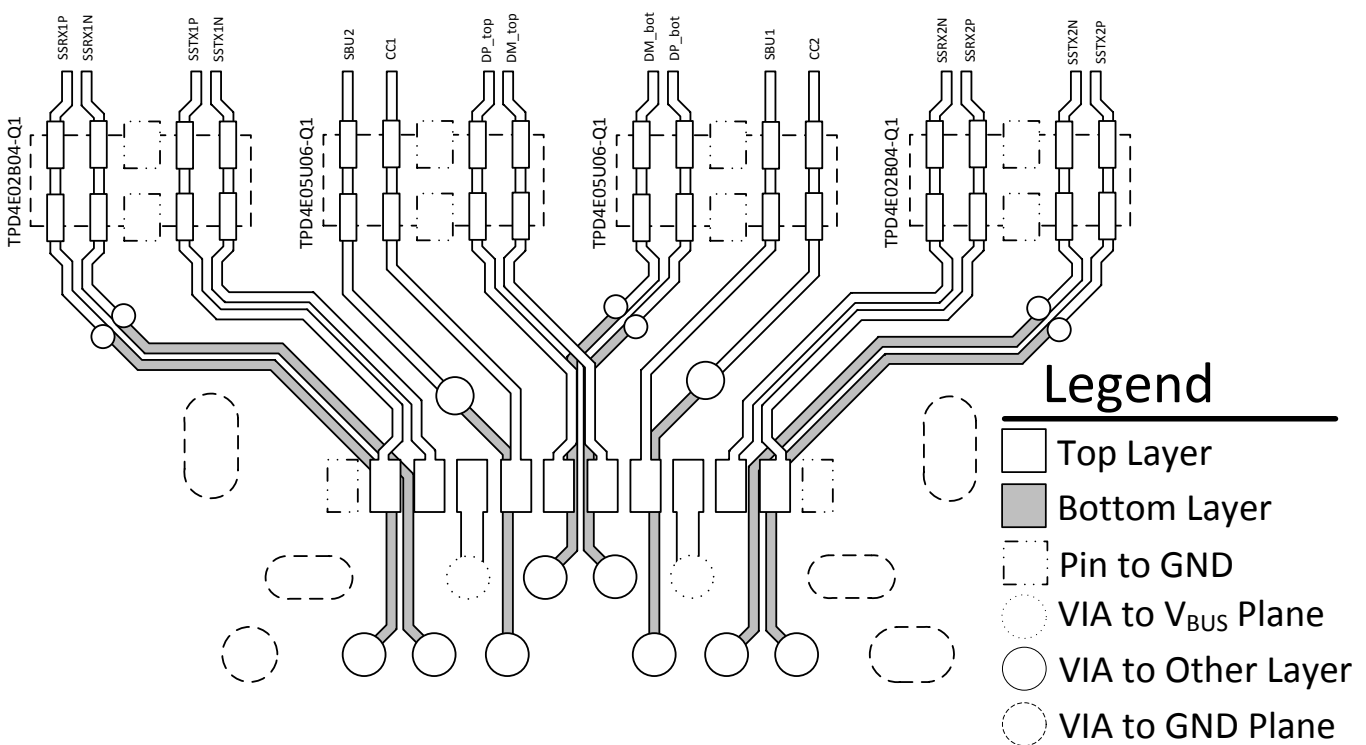







Figure 24. USB Type-C Mid-Mount, Hybrid Connector with One-Sided ESD Layout

Layout Examples (continued)

- Legend**
-  Top Layer
 -  Bottom Layer
 -  Pin to GND
 -  VIA to Other Layer
 -  VIA to GND Plane

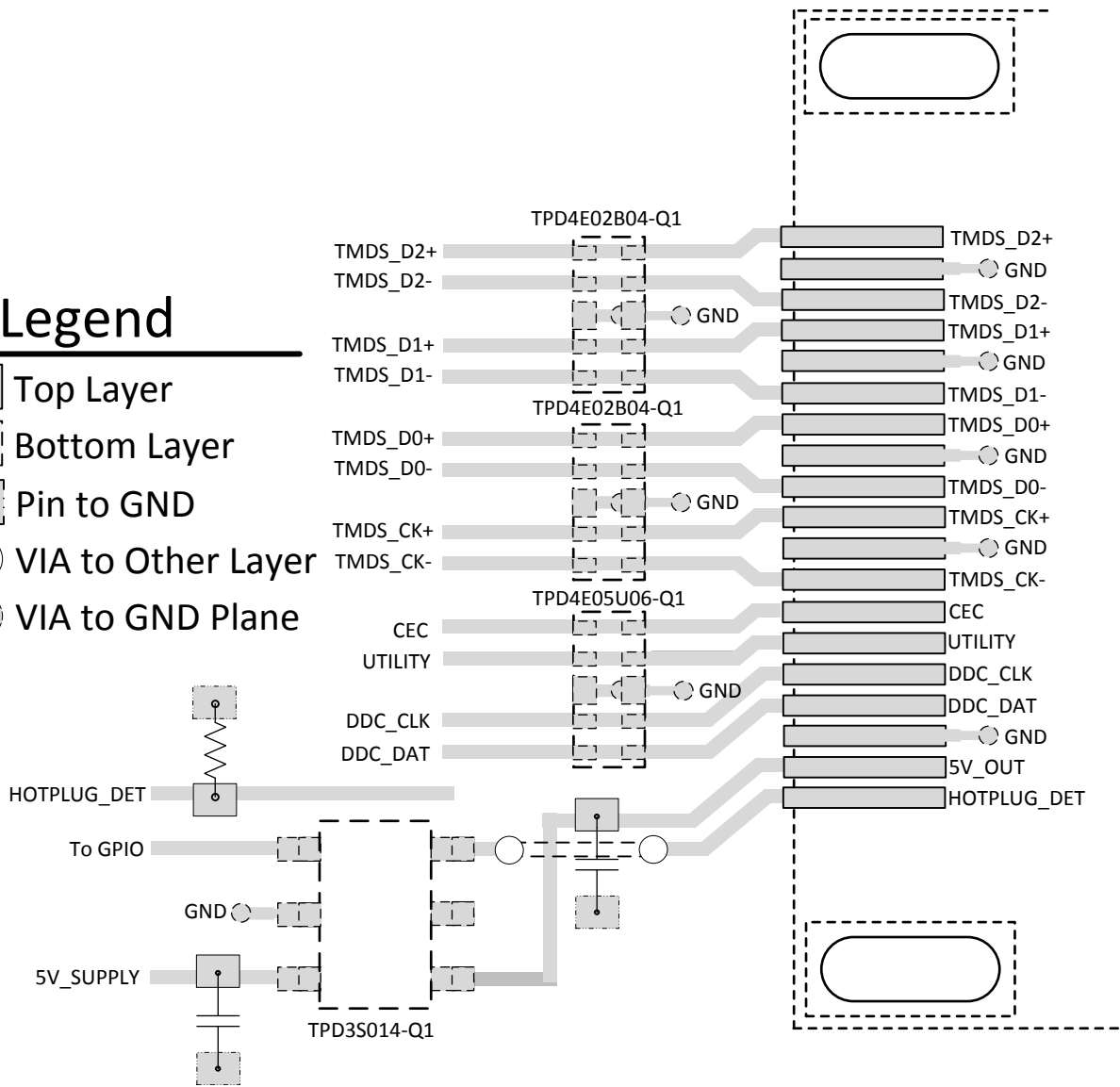

Figure 25. HDMI2.0 Type-A Transmitter Port Layout

11 Device and Documentation Support

11.1 Documentation Support

11.1.1 Related Documentation

For related documentation see the following:

- *Reading and Understanding an ESD Protection Datasheet*, [SLLA305](#)
- *ESD Layout Guide*, [SLVA680](#)
- *Picking ESD Diodes for Ultra High-Speed Data Lines*, [SLVA785](#)
- *TPD4E02B04EVM Users Guide*, [SLVUAH6](#)

11.2 Receiving Notification of Documentation Updates

To receive notification of documentation updates, navigate to the device product folder on ti.com. In the upper right corner, click on *Alert me* to register and receive a weekly digest of any product information that has changed. For change details, review the revision history included in any revised document.

11.3 Community Resources

The following links connect to TI community resources. Linked contents are provided "AS IS" by the respective contributors. They do not constitute TI specifications and do not necessarily reflect TI's views; see TI's [Terms of Use](#).

TI E2E™ Online Community *TI's Engineer-to-Engineer (E2E) Community*. Created to foster collaboration among engineers. At [e2e.ti.com](#), you can ask questions, share knowledge, explore ideas and help solve problems with fellow engineers.

Design Support *TI's Design Support* Quickly find helpful E2E forums along with design support tools and contact information for technical support.

11.4 Trademarks

E2E is a trademark of Texas Instruments.
All other trademarks are the property of their respective owners.

11.5 Electrostatic Discharge Caution



This integrated circuit can be damaged by ESD. Texas Instruments recommends that all integrated circuits be handled with appropriate precautions. Failure to observe proper handling and installation procedures can cause damage.

ESD damage can range from subtle performance degradation to complete device failure. Precision integrated circuits may be more susceptible to damage because very small parametric changes could cause the device not to meet its published specifications.

11.6 Glossary

[SLYZ022](#) — *TI Glossary*.

This glossary lists and explains terms, acronyms, and definitions.

12 Mechanical, Packaging, and Orderable Information

The following pages include mechanical, packaging, and orderable information. This information is the most current data available for the designated devices. This data is subject to change without notice and revision of this document. For browser-based versions of this data sheet, refer to the left-hand navigation.

PACKAGING INFORMATION

Orderable Device	Status (1)	Package Type	Package Drawing	Pins	Package Qty	Eco Plan (2)	Lead finish/ Ball material (6)	MSL Peak Temp (3)	Op Temp (°C)	Device Marking (4/5)	Samples
TPD4E02B04QDQARQ1	ACTIVE	USON	DQA	10	3000	RoHS & Green	NIPDAU	Level-2-260C-1 YEAR	-40 to 125	BQ1	Samples

(1) The marketing status values are defined as follows:

ACTIVE: Product device recommended for new designs.

LIFEBUY: TI has announced that the device will be discontinued, and a lifetime-buy period is in effect.

NRND: Not recommended for new designs. Device is in production to support existing customers, but TI does not recommend using this part in a new design.

PREVIEW: Device has been announced but is not in production. Samples may or may not be available.

OBSOLETE: TI has discontinued the production of the device.

(2) **RoHS:** TI defines "RoHS" to mean semiconductor products that are compliant with the current EU RoHS requirements for all 10 RoHS substances, including the requirement that RoHS substance do not exceed 0.1% by weight in homogeneous materials. Where designed to be soldered at high temperatures, "RoHS" products are suitable for use in specified lead-free processes. TI may reference these types of products as "Pb-Free".

RoHS Exempt: TI defines "RoHS Exempt" to mean products that contain lead but are compliant with EU RoHS pursuant to a specific EU RoHS exemption.

Green: TI defines "Green" to mean the content of Chlorine (Cl) and Bromine (Br) based flame retardants meet JS709B low halogen requirements of <=1000ppm threshold. Antimony trioxide based flame retardants must also meet the <=1000ppm threshold requirement.

(3) MSL, Peak Temp. - The Moisture Sensitivity Level rating according to the JEDEC industry standard classifications, and peak solder temperature.

(4) There may be additional marking, which relates to the logo, the lot trace code information, or the environmental category on the device.

(5) Multiple Device Markings will be inside parentheses. Only one Device Marking contained in parentheses and separated by a "-" will appear on a device. If a line is indented then it is a continuation of the previous line and the two combined represent the entire Device Marking for that device.

(6) Lead finish/Ball material - Orderable Devices may have multiple material finish options. Finish options are separated by a vertical ruled line. Lead finish/Ball material values may wrap to two lines if the finish value exceeds the maximum column width.

Important Information and Disclaimer:The information provided on this page represents TI's knowledge and belief as of the date that it is provided. TI bases its knowledge and belief on information provided by third parties, and makes no representation or warranty as to the accuracy of such information. Efforts are underway to better integrate information from third parties. TI has taken and continues to take reasonable steps to provide representative and accurate information but may not have conducted destructive testing or chemical analysis on incoming materials and chemicals. TI and TI suppliers consider certain information to be proprietary, and thus CAS numbers and other limited information may not be available for release.

In no event shall TI's liability arising out of such information exceed the total purchase price of the TI part(s) at issue in this document sold by TI to Customer on an annual basis.

OTHER QUALIFIED VERSIONS OF TPD4E02B04-Q1 :

- Catalog: [TPD4E02B04](#)

NOTE: Qualified Version Definitions:

- Catalog - TI's standard catalog product

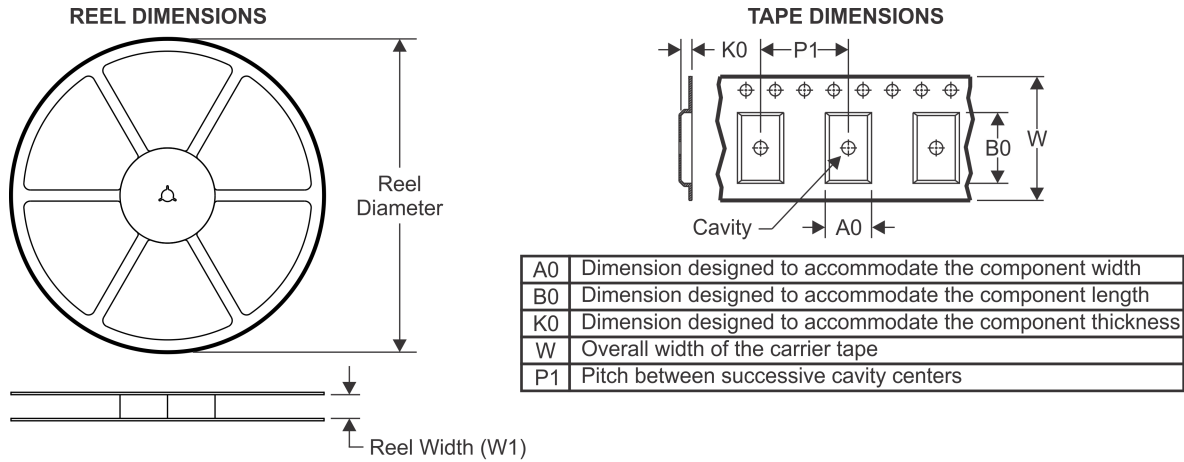
TAPE AND REEL INFORMATION

QUADRANT ASSIGNMENTS FOR PIN 1 ORIENTATION IN TAPE

*All dimensions are nominal

Device	Package Type	Package Drawing	Pins	SPQ	Reel Diameter (mm)	Reel Width W1 (mm)	A0 (mm)	B0 (mm)	K0 (mm)	P1 (mm)	W (mm)	Pin1 Quadrant
TPD4E02B04QDQARQ1	USON	DQA	10	3000	180.0	9.5	1.18	2.68	0.72	4.0	8.0	Q1

TAPE AND REEL BOX DIMENSIONS



*All dimensions are nominal

Device	Package Type	Package Drawing	Pins	SPQ	Length (mm)	Width (mm)	Height (mm)
TPD4E02B04QDQARQ1	USON	DQA	10	3000	189.0	185.0	36.0

EXAMPLE BOARD LAYOUT

DQA0010A

USON - 0.55 mm max height

PLASTIC SMALL OUTLINE - NO LEAD

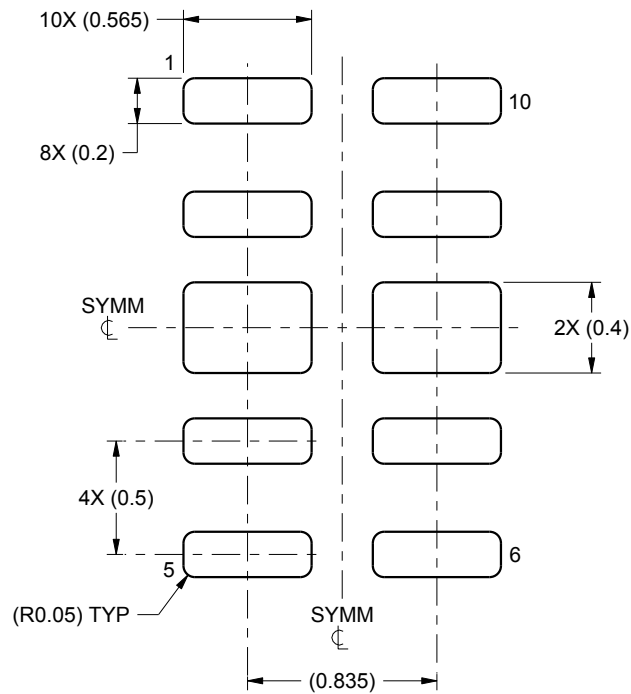

LAND PATTERN EXAMPLE
SCALE:30X

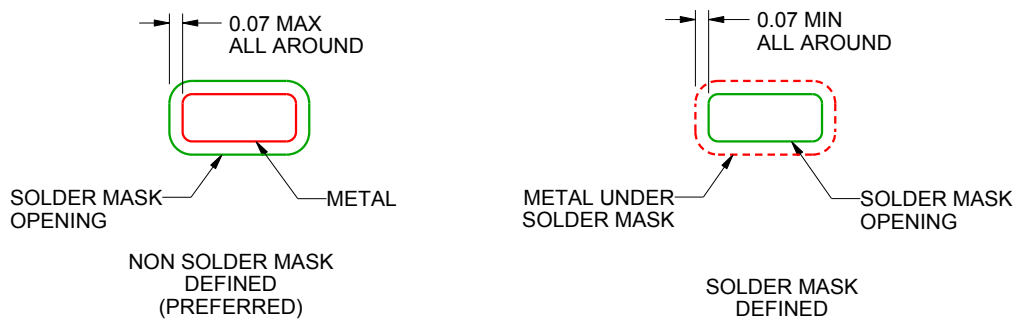

SOLDER MASK DETAILS

4220328/A 12/2015

NOTES: (continued)

3. For more information, see Texas Instruments literature number SLUA271 (www.ti.com/lit/slua271).

IMPORTANT NOTICE AND DISCLAIMER

TI PROVIDES TECHNICAL AND RELIABILITY DATA (INCLUDING DATASHEETS), DESIGN RESOURCES (INCLUDING REFERENCE DESIGNS), APPLICATION OR OTHER DESIGN ADVICE, WEB TOOLS, SAFETY INFORMATION, AND OTHER RESOURCES "AS IS" AND WITH ALL FAULTS, AND DISCLAIMS ALL WARRANTIES, EXPRESS AND IMPLIED, INCLUDING WITHOUT LIMITATION ANY IMPLIED WARRANTIES OF MERCHANTABILITY, FITNESS FOR A PARTICULAR PURPOSE OR NON-INFRINGEMENT OF THIRD PARTY INTELLECTUAL PROPERTY RIGHTS.

These resources are intended for skilled developers designing with TI products. You are solely responsible for (1) selecting the appropriate TI products for your application, (2) designing, validating and testing your application, and (3) ensuring your application meets applicable standards, and any other safety, security, or other requirements. These resources are subject to change without notice. TI grants you permission to use these resources only for development of an application that uses the TI products described in the resource. Other reproduction and display of these resources is prohibited. No license is granted to any other TI intellectual property right or to any third party intellectual property right. TI disclaims responsibility for, and you will fully indemnify TI and its representatives against, any claims, damages, costs, losses, and liabilities arising out of your use of these resources.

TI's products are provided subject to TI's Terms of Sale (www.ti.com/legal/termsofsale.html) or other applicable terms available either on ti.com or provided in conjunction with such TI products. TI's provision of these resources does not expand or otherwise alter TI's applicable warranties or warranty disclaimers for TI products.

Mailing Address: Texas Instruments, Post Office Box 655303, Dallas, Texas 75265
Copyright © 2020, Texas Instruments Incorporated