

具有 2mΩ 精密集成型低电感分流电阻器的 INA253 高电压双向零漂移分流监控器

1 特性

- 精密集成型分流电阻器
 - 分流电阻器: 2mΩ
 - 分流电感: 3nH
 - 分流电阻器容差: 0.1% (最大值)
 - ±15A 持续电流 (–40°C 至 +85°C)
 - 0°C 至 125°C 温度系数: 10ppm/°C
- 高带宽: 350kHz
- 增强型 PWM 抑制
- 出色的 CMRR
 - 直流 CMRR 大于 120dB
 - 90dB AC CMRR (50kHz 时)
- 精度:
 - 增益:
 - 增益误差: 0.4% (最大值)
 - 增益漂移: 45ppm/°C (最大值)
 - 偏移:
 - 失调电流: ±15mA (最大值)
 - 温漂: 125μA/°C (最大值)
- 宽共模范围: –4V 至 +80V
- 可用增益: 100mV/A、200mV/A 和 400mV/A
- 静态电流: 2.4mA (最大值)

2 应用

- 电磁阀控制
- 变速器控制
- 电机控制
- 传动器控制
- 直流/直流转换器
- 远程 I/O 链路控制

3 说明

INA253 是一款电压输出、电流检测放大器，具有一个 2mΩ 的集成型分流电阻器。INA253 可独立于电源电压在 –4V 至 +80V 的宽共模范围内监控双向电流。它具有三个固定增益: 100mV/A、200mV/A 和 400mV/A。通过将精密电阻器和零漂移斩波放大器整合在一起，它可以实现校准等效测量精度、15ppm/°C 的超低温漂和优化的感应电阻器开尔文布局。

INA253 采用了增强型 PWM 抑制电路，可抑制较大的 (dv/dt) 信号，从而实现实时持续电流测量。这种测量对于电机驱动应用中的嵌入式电流测量以及对于电磁阀控制应用均至关重要。

该器件由 2.7 V 至 5.5 V 的单电源供电运行，消耗的最大电源电流为 3mA。所有增益版本都具有扩展的工作温度范围 (–40°C 至 +125°C)，并采用 20 引脚 TSSOP 封装。

器件信息(1)

器件型号	封装	封装尺寸 (标称值)
INA253	TSSOP (20)	6.50mm × 4.40mm

(1) 如需了解所有可用封装，请参阅数据表末尾的封装选项附录。

典型应用

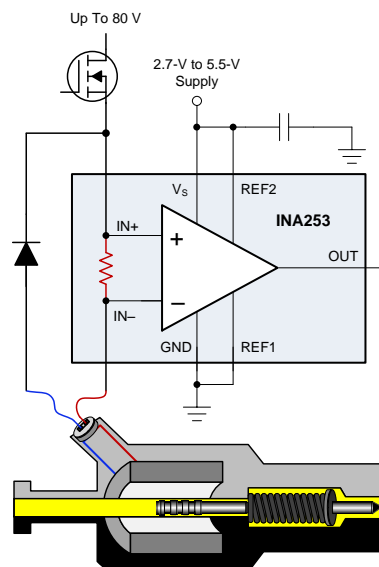

目录

1	特性	1	8.4	Device Functional Modes.....	16
2	应用	1	9	Application and Implementation	19
3	说明	1	9.1	Application Information.....	19
4	修订历史记录	2	9.2	Typical Applications	21
5	Device Comparison Table	3	10	Power Supply Recommendations	27
6	Pin Configuration and Functions	3	11	Layout	27
7	Specifications	4	11.1	Layout Guidelines	27
7.1	Absolute Maximum Ratings	4	11.2	Layout Example	27
7.2	ESD Ratings.....	4	12	器件和文档支持	28
7.3	Recommended Operating Conditions	4	12.1	器件支持	28
7.4	Thermal Information	4	12.2	相关文档	28
7.5	Electrical Characteristics.....	5	12.3	接收文档更新通知	28
7.6	Typical Characteristics	7	12.4	社区资源	28
8	Detailed Description	12	12.5	商标	28
8.1	Overview	12	12.6	静电放电警告	28
8.2	Functional Block Diagram	12	12.7	术语表	28
8.3	Feature Description.....	12	13	机械、封装和可订购信息	28

4 修订历史记录

Changes from Original (July 2018) to Revision A

Page

• 已更改 器件状态从预告信息改为生产数据（正在供货）	1
-----------------------------------	----------

5 Device Comparison Table

PRODUCT	GAIN (mV/A)
INA253A1	100
INA253A2	200
INA253A3	400

6 Pin Configuration and Functions

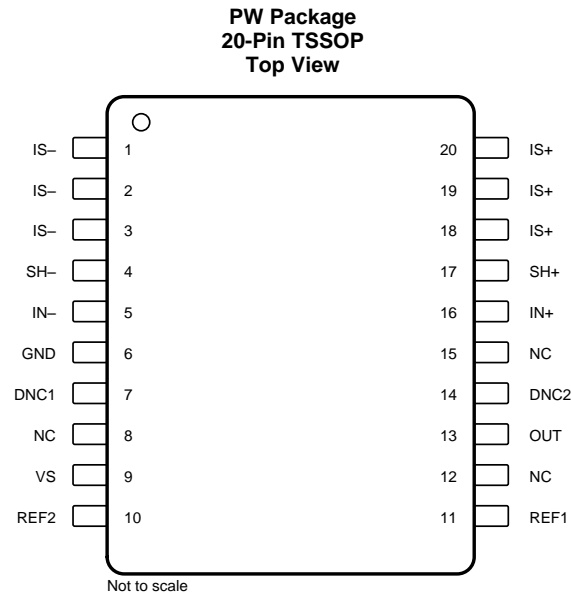

Pin Functions

PIN		I/O	DESCRIPTION
NO.	NAME		
1	IS-	Analog input	Connect to load
2	IS-	Analog input	Connect to load
3	IS-	Analog input	Connect to load
4	SH-	Analog output	Kelvin connection to internal shunt. Connect to IN- if no filtering is needed
5	IN-	Analog input	Voltage input from load side of shunt resistor
6	GND	—	Ground
7	DNC1	—	Do not connect this pin to any potential; leave this pin floating.
8	NC	—	No connect
9	VS	Analog	Power supply, 2.7 V to 5.5 V
10	REF2	Analog input	Reference voltage 2, 0 V to VS
11	REF1	Analog input	Reference voltage 1, 0 V to VS
12	NC	—	No connect
13	OUT	Analog	Output voltage
14	DNC2	—	Do not connect this pin to any potential; leave this pin floating.
15	NC	Analog	Reserved; connect this pin to ground
16	IN+	Analog input	Voltage input from supply side of shunt resistor
17	SH+	Analog output	Kelvin connection to internal shunt. Connect to IN+ if no filtering is needed
18	IS+	Analog input	Connect to supply
19	IS+	Analog input	Connect to supply
20	IS+	Analog input	Connect to supply

7 Specifications

7.1 Absolute Maximum Ratings

 over operating free-air temperature range (unless otherwise noted)⁽¹⁾

		MIN	MAX	UNIT
Supply voltage			6	V
Shunt input current (I_{SENSE})	Continuous		±15	A
Analog inputs (IS+, IS–)	Common-mode	GND – 6	90	V
Analog inputs (V_{IN+}, V_{IN-})	Differential ($V_{IN+} - V_{IN-}$)	–80	80	V
	Common-mode	GND – 6	90	V
Analog inputs (REF1, REF2, NC)		GND – 0.3	$V_S + 0.3$	V
Analog outputs (SH+, SH–)	Common-mode	GND – 6	90	V
Analog output (OUT)		GND – 0.3	$V_S + 0.3$	V
Temperature	Operating, T_A	–55	150	°C
	Junction, T_J		150	°C
	Storage, T_{stg}	–65	150	°C

(1) Stresses beyond those listed under *Absolute Maximum Ratings* may cause permanent damage to the device. These are stress ratings only, which do not imply functional operation of the device at these or any other conditions beyond those indicated under *Recommended Operating Conditions*. Exposure to absolute-maximum-rated conditions for extended periods may affect device reliability.

7.2 ESD Ratings

			VALUE	UNIT
$V_{(ESD)}$	Electrostatic discharge	Human-body model (HBM), per ANSI/ESDA/JEDEC JS-001 ⁽¹⁾	±2000	V
		Charged-device model (CDM), per JEDEC specification JESD22-C101 ⁽²⁾	±1000	

(1) JEDEC document JEP155 states that 500-V HBM allows safe manufacturing with a standard ESD control process.

(2) JEDEC document JEP157 states that 250-V CDM allows safe manufacturing with a standard ESD control process.

7.3 Recommended Operating Conditions

over operating free-air temperature range (unless otherwise noted)

		MIN	NOM	MAX	UNIT
V_{CM}	Common-mode input voltage	–4		80	V
V_S	Operating supply voltage	2.7		5.5	V
T_A	Operating free-air temperature	–40		125	°C

7.4 Thermal Information

THERMAL METRIC ⁽¹⁾		INA253	UNIT
		PW (TSSOP)	
		20 PINS	
$R_{\theta JA}$	Junction-to-ambient thermal resistance	110.6	°C/W
$R_{\theta JC(top)}$	Junction-to-case (top) thermal resistance	54.1	°C/W
$R_{\theta JB}$	Junction-to-board thermal resistance	87.5	°C/W
Ψ_{JT}	Junction-to-top characterization parameter	114.1	°C/W
Ψ_{JB}	Junction-to-board characterization parameter	87.5	°C/W

(1) For more information about traditional and new thermal metrics, see the [Semiconductor and IC Package Thermal Metrics](#) application report.

7.5 Electrical Characteristics

at $T_A = 25^\circ\text{C}$, $V_S = 5\text{ V}$, $I_{\text{SENSE}} = I_{\text{S+}} = 0\text{ A}$, $V_{\text{CM}} = 12\text{ V}$, and $V_{\text{REF1}} = V_{\text{REF2}} = V_S / 2$ (unless otherwise noted)

PARAMETER		TEST CONDITIONS	MIN	TYP	MAX	UNIT	
INPUT							
V_{CM}	Common-mode input range	$V_{\text{IN+}} = -4\text{ V to } +80\text{ V}$, $I_{\text{SENSE}} = 0\text{ A}$, $T_A = -40^\circ\text{C to } +125^\circ\text{C}$	-4		80	V	
CMR	Common-mode rejection	$V_{\text{IN+}} = -4\text{ V to } +80\text{ V}$, $I_{\text{SENSE}} = 0\text{ A}$, $T_A = -40^\circ\text{C to } +125^\circ\text{C}$		± 125	± 500	$\mu\text{A/V}$	
		$f = 50\text{ kHz}$		± 13		mA/V	
I_{OS}	Offset current, input-referred	$I_{\text{SENSE}} = 0\text{ A}$		± 2.5	± 15	mA	
dI_{OS}/dT	Offset current drift	$I_{\text{SENSE}} = 0\text{ A}$, $T_A = -40^\circ\text{C to } +125^\circ\text{C}$		25	125	$\mu\text{A}/^\circ\text{C}$	
PSRR	Power-supply rejection ratio	$V_S = 2.7\text{ V to } 5.5\text{ V}$, $I_{\text{SENSE}} = 0\text{ A}$		± 0.5	± 5	mA/V	
I_{B}	Input bias current	$I_{\text{B+}}$, $I_{\text{B-}}$, $I_{\text{SENSE}} = 0\text{ A}$		90		μA	
	Reference input range		0		V_S	V	
SHUNT RESISTOR							
R_{SHUNT}	Shunt resistance (SH+ to SH-)	Equivalent resistance when used with onboard amplifier	1.998	2	2.002	$\text{m}\Omega$	
		Used as stand-alone resistor ⁽¹⁾	1.9	2	2.1		
	Package resistance	IS+ to IS-		4.5		$\text{m}\Omega$	
	Package inductance	IS+ to IS-		3		nH	
	Resistor temperature coefficient	$T_A = -40^\circ\text{C to } +125^\circ\text{C}$		15		$\text{ppm}/^\circ\text{C}$	
		$T_A = -40^\circ\text{C to } 0^\circ\text{C}$		50			
		$T_A = 0^\circ\text{C to } 125^\circ\text{C}$		10		$\text{ppm}/^\circ\text{C}$	
I_{SENSE}	Maximum continuous current ⁽²⁾	$T_A = -40^\circ\text{C to } +85^\circ\text{C}$			± 15	A	
	Shunt short time overload	$I_{\text{SENSE}} = 30\text{ A}$ for 5 seconds		$\pm 0.05\%$			
	Shunt thermal shock	$-65^\circ\text{C to } +150^\circ\text{C}$, 500 cycles		$\pm 0.1\%$			
	Shunt resistance to solder heat	260°C solder, 10 seconds		$\pm 0.1\%$			
	Shunt high temperature exposure	1000 hours, $T_A = 150^\circ\text{C}$		$\pm 0.15\%$			
	Shunt cold temperature storage	24 hours, $T_A = -65^\circ\text{C}$		$\pm 0.025\%$			
	OUTPUT						
	G	Gain	INA253A1		100		mV/A
INA253A2				200			
INA253A3				400		mV/A	
	System gain error ⁽³⁾	$\text{GND} + 50\text{ mV} \leq V_{\text{OUT}} \leq V_S - 200\text{ mV}$, $T_A = 25^\circ\text{C}$		$\pm 0.05\%$	$\pm 0.4\%$		
		$T_A = -40^\circ\text{C to } +125^\circ\text{C}$			± 45	$\text{ppm}/^\circ\text{C}$	
	Nonlinearity error	$\text{GND} + 10\text{ mV} \leq V_{\text{OUT}} \leq V_S - 200\text{ mV}$		$\pm 0.01\%$			
	Reference divider accuracy	$V_{\text{OUT}} = (V_{\text{REF1}} - V_{\text{REF2}}) / 2$ at $I_{\text{SENSE}} = 0\text{ A}$, $T_A = -40^\circ\text{C to } +125^\circ\text{C}$		0.02%	0.1%		
RVRR	Reference voltage rejection ratio (input-referred)	INA253A2		2.5		mA/V	
		INA253A1, INA253A3		1			
	Maximum capacitive load	No sustained oscillation		1		nF	
VOLTAGE OUTPUT							
	Swing to V_S power-supply rail	$R_L = 10\text{ k}\Omega$ to GND, $T_A = -40^\circ\text{C to } +125^\circ\text{C}$		$V_S - 0.05$	$V_S - 0.2$	V	
	Swing to GND	$R_L = 10\text{ k}\Omega$ to GND, $I_{\text{SENSE}} = 0\text{ A}$, $V_{\text{REF1}} = V_{\text{REF2}} = 0\text{ V}$, $T_A = -40^\circ\text{C to } +125^\circ\text{C}$		$V_{\text{GND}} + 1$	$V_{\text{GND}} + 10$	mV	

- (1) The internal shunt resistor is intended to be used with the internal amplifier and is not intended to be used as a stand-alone resistor. See the [Integrated Shunt Resistor](#) section for more information.
- (2) See [Maximum Continuous Current](#) for additional information on the current derating and review [layout](#) recommendations to improve the current handling capability of the device at higher temperatures.
- (3) System gain error includes amplifier gain error and the integrated sense resistor tolerance. System gain error does not include the stress related characteristics of the integrated sense resistor. These characteristics are described in the [Shunt Resistor](#) section of the [Electrical Characteristics](#) table.

Electrical Characteristics (continued)

 at $T_A = 25\text{ }^\circ\text{C}$, $V_S = 5\text{ V}$, $I_{\text{SENSE}} = I_{\text{S}+} = 0\text{ A}$, $V_{\text{CM}} = 12\text{ V}$, and $V_{\text{REF1}} = V_{\text{REF2}} = V_S / 2$ (unless otherwise noted)

PARAMETER		TEST CONDITIONS	MIN	TYP	MAX	UNIT
FREQUENCY RESPONSE						
BW	Bandwidth ⁽⁴⁾	All gains, –3-dB bandwidth		350		kHz
		All gains, 2% THD+N ⁽⁴⁾		100		kHz
	Output settling time	Settles to 0.5% of final value		10		μs
SR	Slew rate			2.4		V/μs
NOISE (Input Referred)						
	Voltage noise density			40		nV/√Hz
POWER SUPPLY						
V_S	Operating voltage range	$T_A = -40\text{ }^\circ\text{C}$ to $+125\text{ }^\circ\text{C}$	2.7		5.5	V
I_Q	Quiescent current	$I_{\text{SENSE}} = 0\text{ A}$		1.8	2.4	mA
		I_Q vs temperature, $T_A = -40\text{ }^\circ\text{C}$ to $+125\text{ }^\circ\text{C}$			2.6	

 (4) See [Bandwidth](#) section for more details.

7.6 Typical Characteristics

at $T_A = 25^\circ\text{C}$, $V_S = 5\text{ V}$, $V_{IN+} = 12\text{ V}$, and $V_{REF} = V_S / 2$ (unless otherwise noted)



图 1. Input Offset Voltage Production Distribution



图 2. Input Offset Current vs Temperature

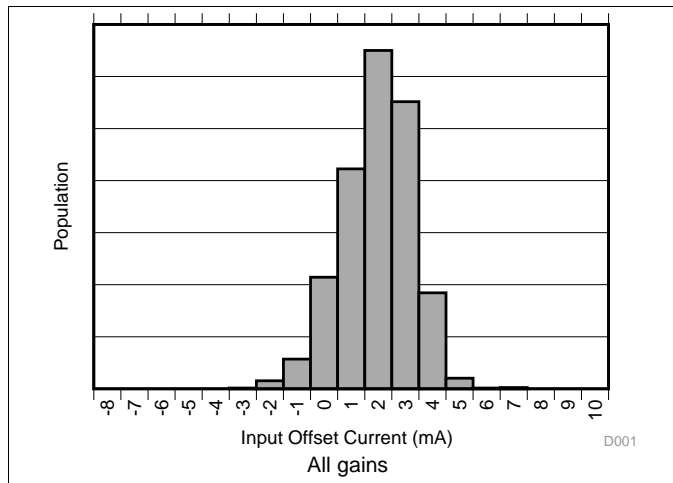

图 3. Common-Mode Rejection Production Distribution

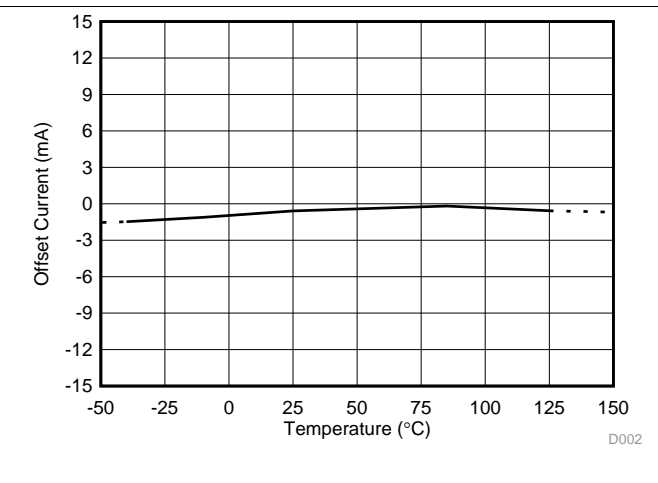

图 4. Common-Mode Rejection Ratio vs Temperature

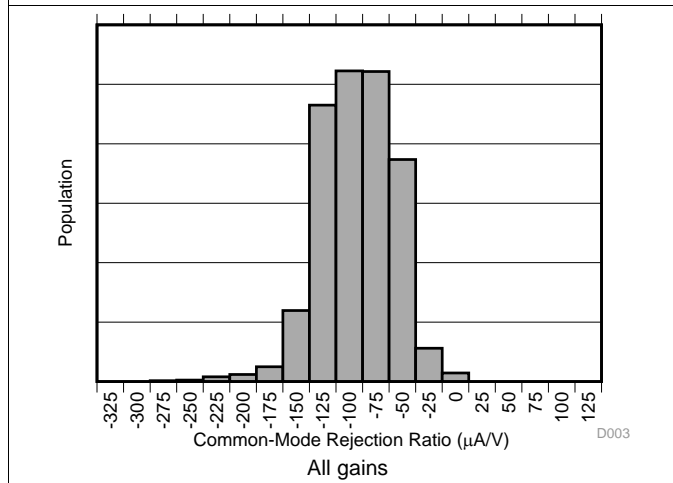

图 5. Power-Supply Rejection Ratio vs Temperature

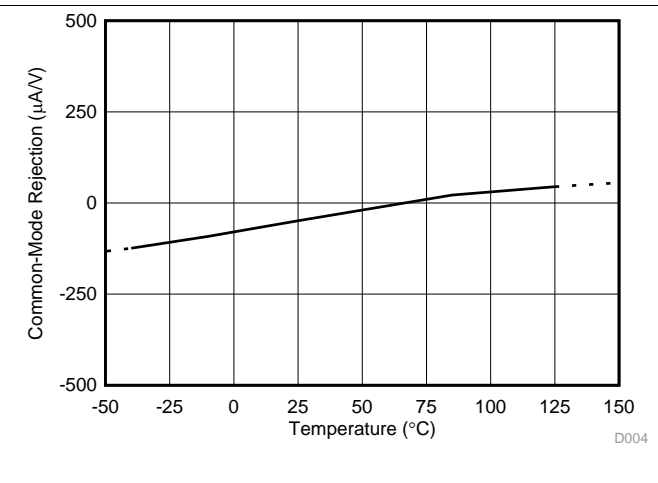

图 6. Gain Error Production Distribution (INA253A1)

Typical Characteristics (接下页)

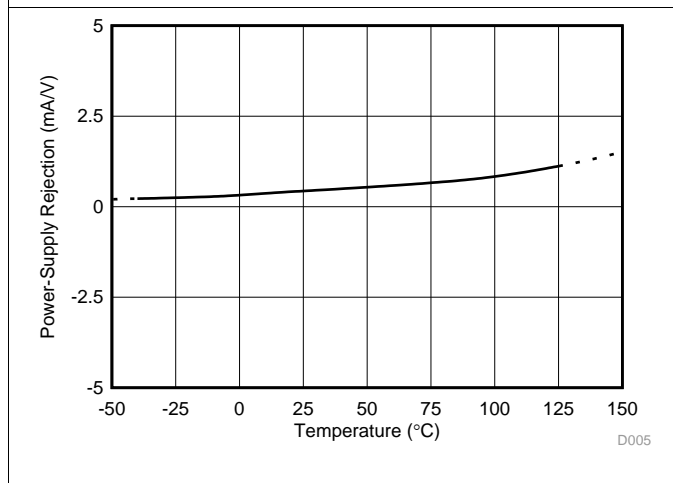
at $T_A = 25^\circ\text{C}$, $V_S = 5\text{ V}$, $V_{IN+} = 12\text{ V}$, and $V_{REF} = V_S / 2$ (unless otherwise noted)

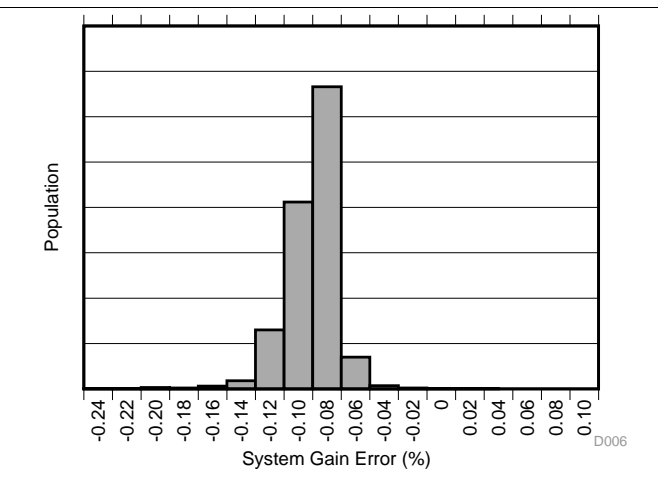
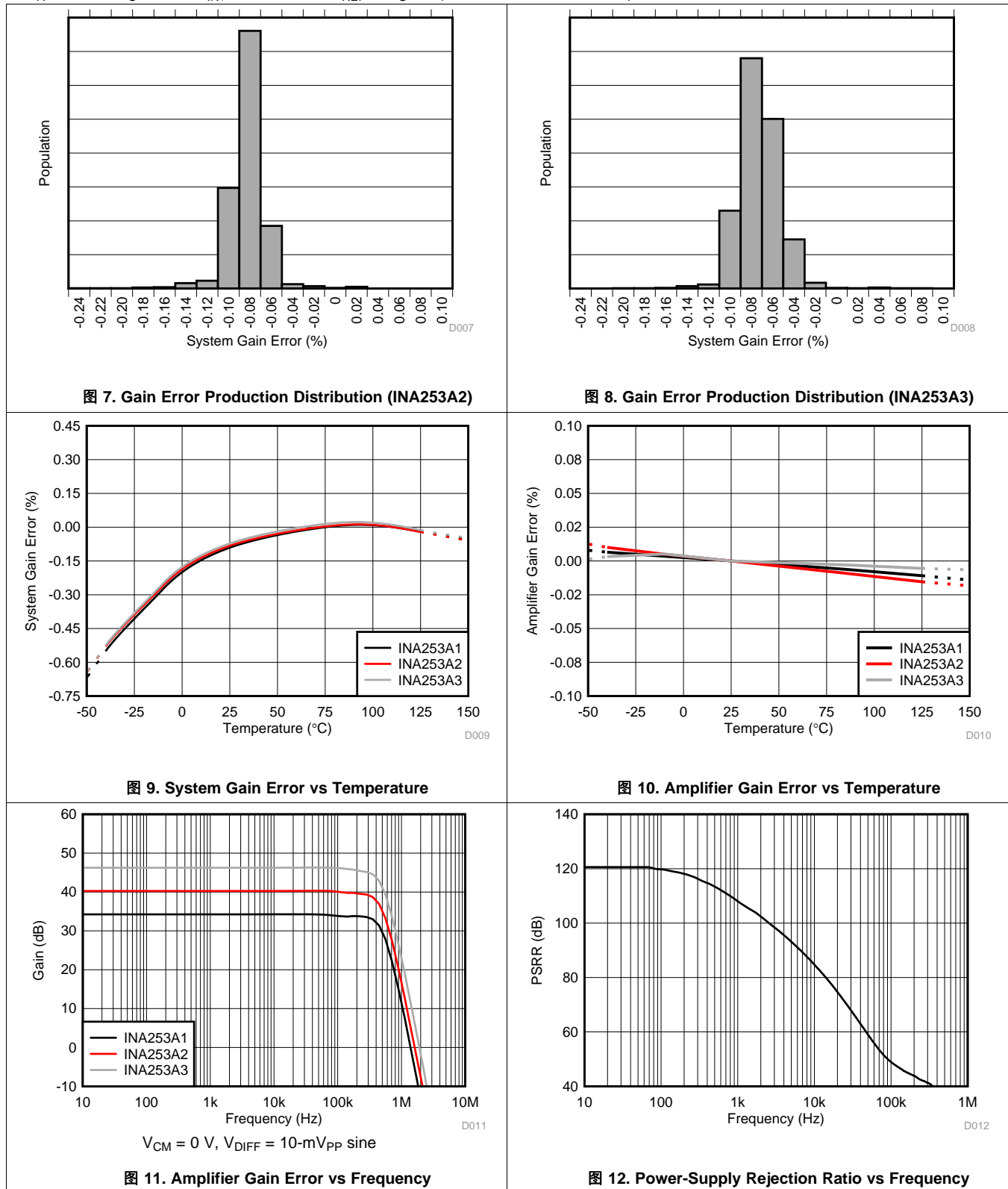

Typical Characteristics (接下页)

at $T_A = 25^\circ\text{C}$, $V_S = 5\text{ V}$, $V_{IN+} = 12\text{ V}$, and $V_{REF} = V_S / 2$ (unless otherwise noted)

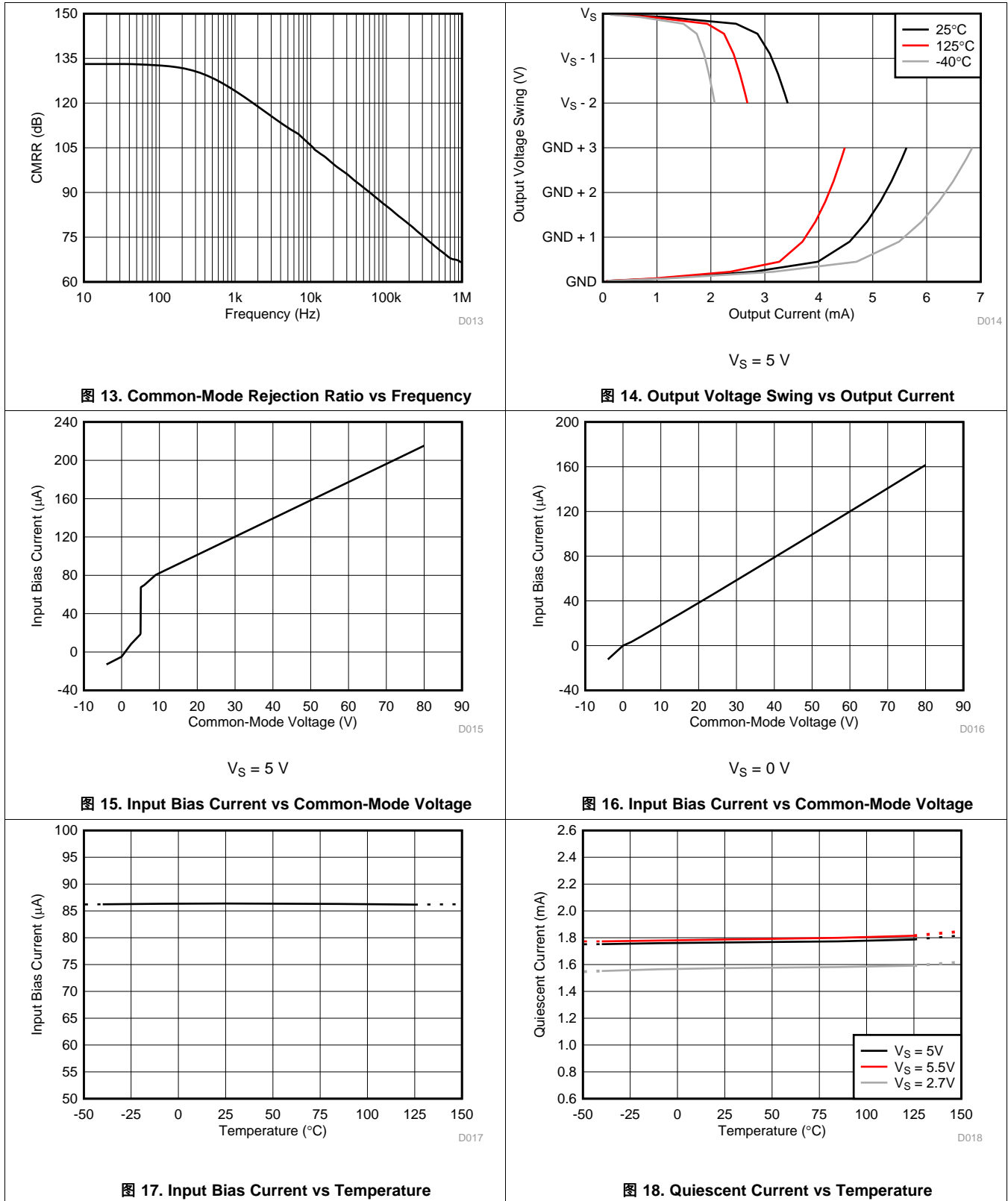

Typical Characteristics (接下页)

at $T_A = 25^\circ\text{C}$, $V_S = 5\text{ V}$, $V_{IN+} = 12\text{ V}$, and $V_{REF} = V_S / 2$ (unless otherwise noted)

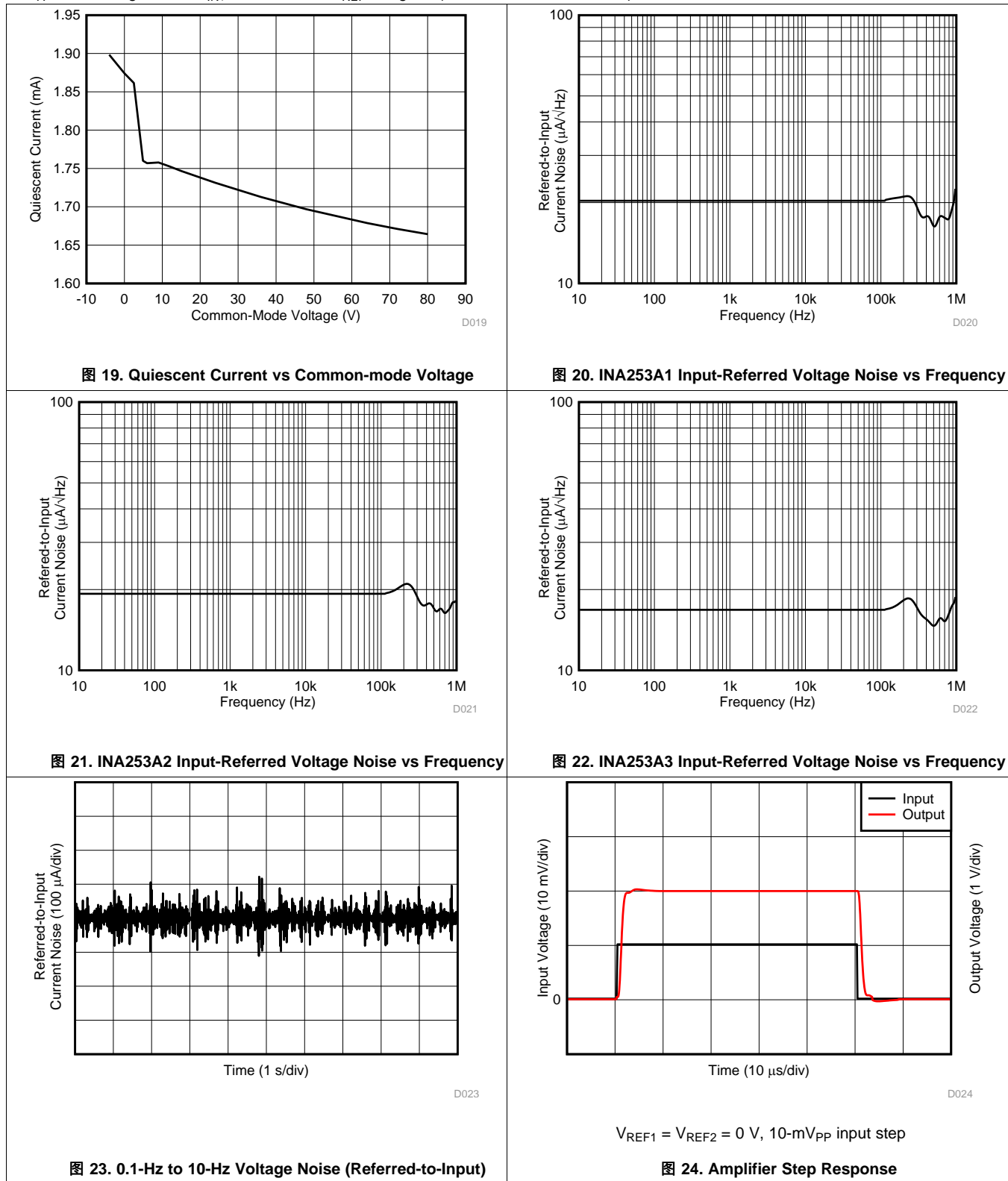

Typical Characteristics (接下页)

at $T_A = 25^\circ\text{C}$, $V_S = 5\text{ V}$, $V_{IN+} = 12\text{ V}$, and $V_{REF} = V_S / 2$ (unless otherwise noted)

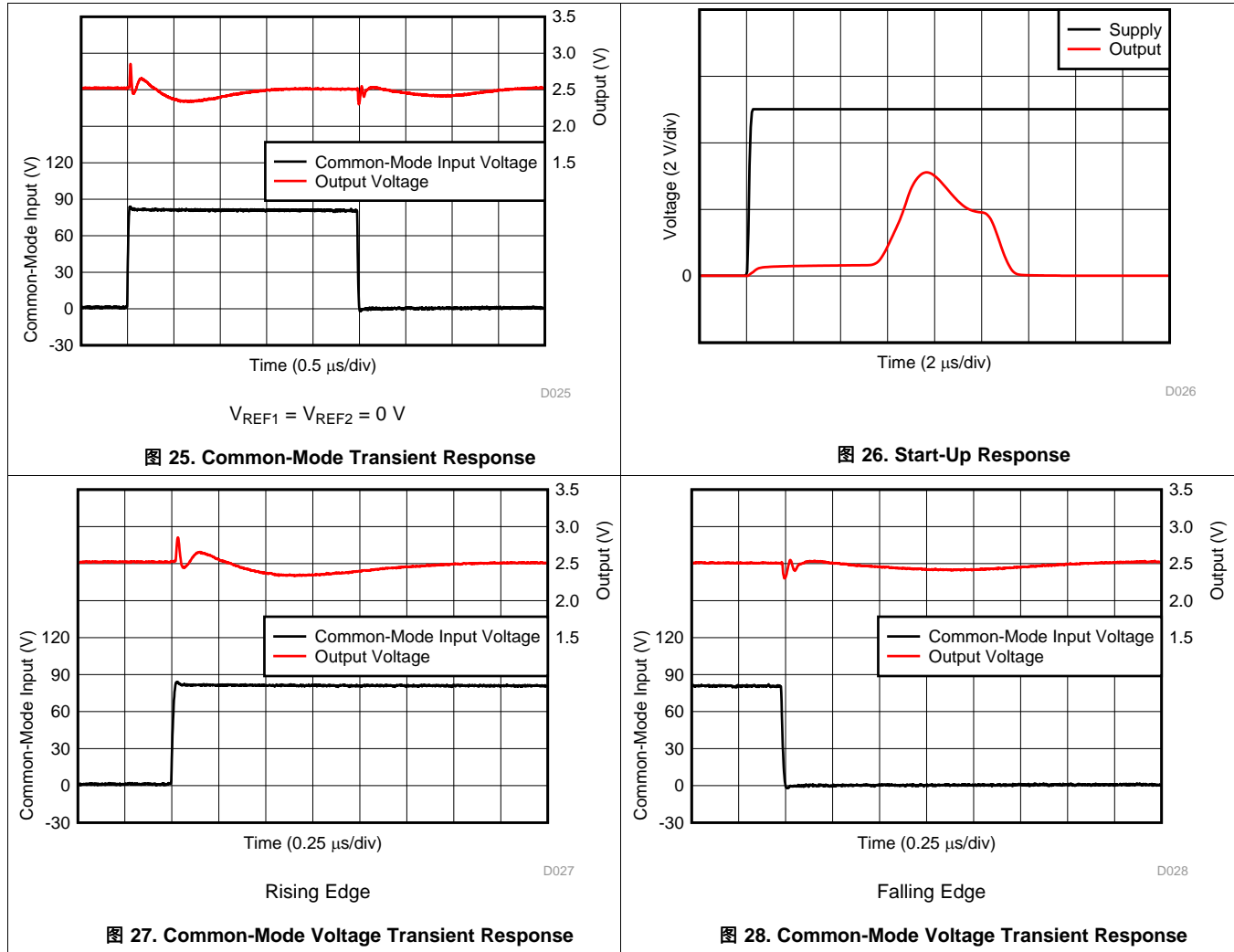

8 Detailed Description

8.1 Overview

The INA253 features a precision, 2-m Ω current-sensing resistor and supports common mode voltages up to 80 V. The internal amplifier features a precision zero-drift topology with excellent common-mode rejection ratio (CMRR). The internal amplifier also features an enhanced pulse-width modulation (PWM) rejection current-sensing amplifier integrated into a single package. High-precision measurements are enabled by matching the shunt resistor value and the current-sensing amplifier gain, thus providing a highly-accurate, system-calibrated method for measuring current. Enhanced PWM rejection reduces the effect of common-mode transients on the output signal that are associated with PWM signals. Multiple gain versions are available to allow for the optimization of the desired full-scale output voltage based on the target current range expected in the application.

8.2 Functional Block Diagram

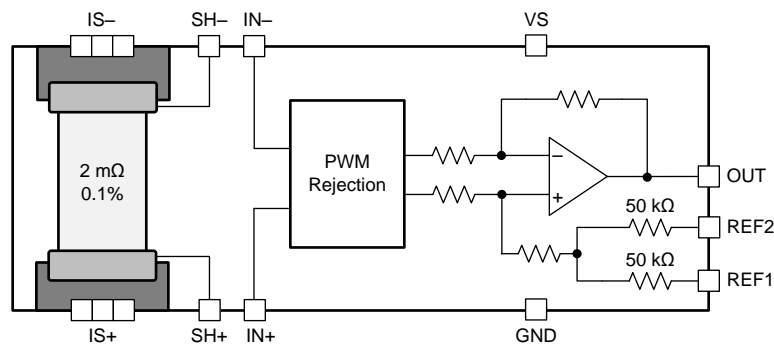

8.3 Feature Description

8.3.1 Integrated Shunt Resistor

The INA253 features a precise, low-drift, current-sensing resistor that provides accurate measurements over the entire specified temperature range of -40°C to $+125^{\circ}\text{C}$. The integrated current-sensing resistor provides measurement stability over temperature, and simplifies printed circuit board (PCB) layout and board constraint difficulties common in high-precision measurements.

The onboard current-sensing resistor is designed as a 4-wire (or Kelvin) connected resistor that enables accurate measurements through a force-sense connection. Connecting the amplifier inputs pins (VIN- and VIN+) to the sense pins of the shunt resistor (SH- and SH+) eliminates many of the parasitic impedances commonly found in typical very-low sensing-resistor level measurements. Although the sense connection of the current-sensing resistor can be accessed through the SH+ and SH- pins, this resistor is not intended to be used as a stand-alone component. The INA253 is system-calibrated to make sure that the current-sensing resistor and current-sensing amplifier are both precisely matched to one another. Use of the shunt resistor without the onboard amplifier results in a current-sensing resistor tolerance of approximately 5%. To achieve the optimized system gain specification, the onboard sensing resistor must be used with the internal current-sensing amplifier.

The INA253 has approximately 4.5 m Ω of package resistance. Of this total package resistance, 2 m Ω is a precisely-controlled resistance from the Kelvin-connected current-sensing resistor used by the amplifier. The power dissipation requirements of the system and package are based on the total 4.5-m Ω package resistance between the IS+ and IS- pins. The heat dissipated across the package when current flows through the device ultimately determines the maximum current that can be safely handled by the package. The current consumption of the silicon is relatively low, leaving the total package resistance to carry the high load current as the primary contributor to the total power dissipation of the package. The maximum safe-operating current level is set to make sure that the heat dissipated across the package is limited so that no damage occurs to the resistor or the package, or that the internal junction temperature of the silicon does not exceed a 150°C limit.

Feature Description (接下页)

External factors, such as ambient temperature, external air flow, and PCB layout, contribute to how effectively the device dissipates heat. The internal heat is developed as a result of the current flowing through the total package resistance of 4.5 mΩ. Under the conditions of no air flow, a maximum ambient temperature of 85°C, and 1-oz. copper input power planes, the INA253 accommodates continuous current levels up to 15 A. 图 29 shows that the current-handling capability is derated at temperatures greater than the 85°C level, with safe operation up to 10 A at a 125°C ambient temperature. With air flow and larger 2-oz. copper input power planes, the INA253 safely accommodates continuous current levels up to 15 A across the entire -40°C to +125°C temperature range.



图 29. Maximum Continuous Current vs Temperature

8.3.2 Short-Circuit Duration

The INA253 features a physical shunt resistance that is able to withstand current levels higher than the continuous handling limit of 15 A without sustaining damage to the current-sensing resistor or the current-sensing amplifier, if the excursions are brief. 图 30 shows the short-circuit duration curve for the INA253.

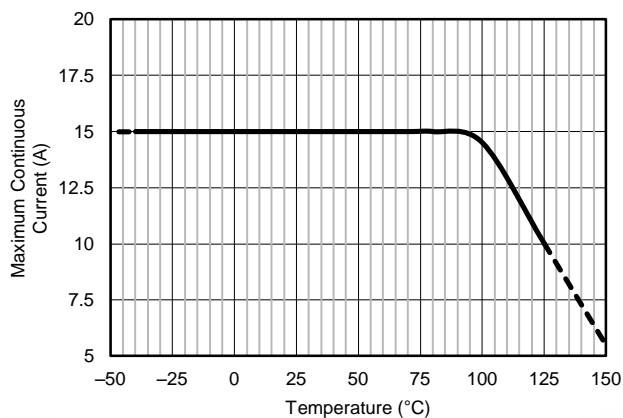

图 30. Short-Circuit Duration

Feature Description (接下页)

8.3.3 Temperature Stability

System calibration is common for many industrial applications in order to eliminate initial component and system-level errors that can be present. A system-level calibration reduces the initial accuracy requirement for many of the individual components because the errors associated with these components are effectively eliminated through the calibration procedure. This calibration enables precise measurements at the temperature in which the system is calibrated. As the system temperature changes because of external ambient changes or self heating, measurement errors are reintroduced. Without accurate temperature compensation used in addition to the initial adjustment, the calibration procedure is not effective. The user must account for temperature-induced changes. One of the primary benefits of the low temperature coefficient of the INA253 (including both the integrated current-sensing resistor and current-sensing amplifier) is that the device measurement remains accurate, even when the temperature changes throughout the specified temperature range of the device.

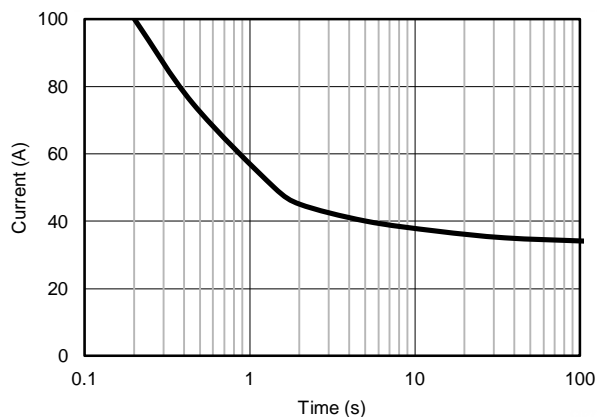
图 31 shows the drift performance for the integrated current-sensing resistor. Use 图 31 to determine the typical variance in the shunt resistor value at various temperatures. As with any resistive element, the tolerance of the component varies when exposed to different temperature conditions. For the current-sensing resistor integrated in the INA253, the resistor does vary slightly more when operated in temperatures ranging from -40°C to 0°C than when operated from 0°C to 125°C . Even in the -40°C to 0°C temperature range, the drift is still low at 25 ppm/ $^{\circ}\text{C}$.



图 31. Sensing Resistor vs Temperature

An additional aspect to consider is that when current flows through the current-sensing resistor, power is dissipated across this component. This dissipated power results in an increase in the internal temperature of the package, including the integrated sensing resistor. This resistor self-heating effect results in an increase of the resistor temperature helping to move the component out of the colder, wider drift temperature region.

8.3.4 Enhanced PWM Rejection Operation

The enhanced PWM rejection feature of the INA253 provides increased attenuation of large common-mode $\Delta V/\Delta t$ transients. Large $\Delta V/\Delta t$ common-mode transients associated with PWM signals are employed in applications such as motor or solenoid drive and switching power supplies. Traditionally, large $\Delta V/\Delta t$ common-mode transients are handled strictly by increasing the amplifier signal bandwidth, which can increase chip size, complexity and ultimately cost. The INA253 is designed with high common-mode rejection techniques to reduce large $\Delta V/\Delta t$ transients before the system is disturbed as a result of these large signals. The high ac CMRR, in conjunction with signal bandwidth, allows the INA253 to provide minimal output transients and ringing compared with standard circuit approaches.

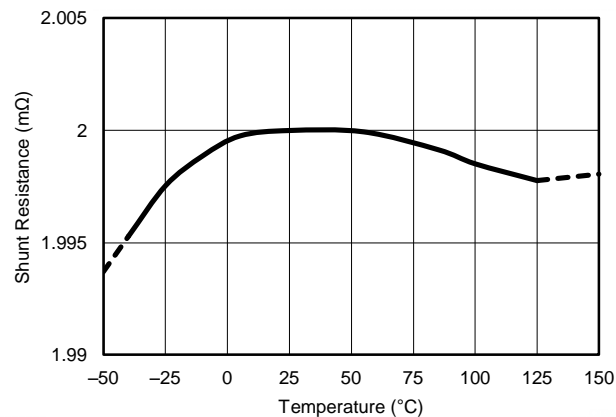
Feature Description (接下页)

8.3.5 Input Signal Bandwidth

The INA253 input signal, which represents the current being measured, is accurately measured with minimal disturbance from large $\Delta V/\Delta t$ common-mode transients as previously described. For PWM signals typically associated with motors, solenoids, and other switching applications, the current being monitored varies at a significantly slower rate than the faster PWM frequency.

The INA253 bandwidth is defined by the -3 -dB bandwidth of the current-sense amplifier inside the device; see the [Electrical Characteristics](#) for more information. The device bandwidth provides fast throughput and fast response required for the rapid detection and processing of overcurrent events. Without the higher bandwidth, protection circuitry may not have adequate response time, and damage may occur to the monitored application or circuit.

图 32 shows the performance profile of the device over frequency. Harmonic distortion increases at the upper end of the amplifier bandwidth with no adverse change in detection of overcurrent events. However, increased distortion at the highest frequencies must be considered when the measured current bandwidth begins to approach the INA253 bandwidth.



图 32. Amplifier Performance Over Frequency

For applications requiring distortion sensitive signals, 图 32 provides information to show that there is an optimal frequency performance range for the amplifier. The full amplifier bandwidth is always available for fast overcurrent events at the same time that the lower-frequency signals are amplified at a low distortion level. The output signal accuracy is reduced for frequencies closer to the maximum bandwidth. Individual requirements determine the acceptable limits of distortion for high-frequency, current-sensing applications. Testing and evaluation in the end application or circuit are required to determine the acceptance criteria, and to validate the performance levels meet the system specifications.

8.4 Device Functional Modes

8.4.1 Adjusting the Output Midpoint With the Reference Pins

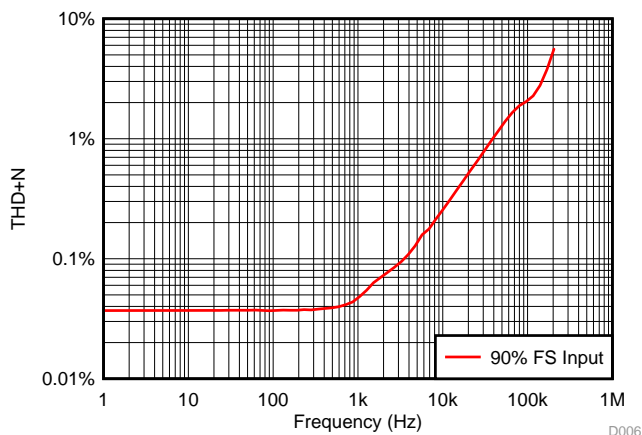
图 33 shows a test circuit for reference-divider accuracy. The INA253 output is configurable to allow for unidirectional or bidirectional operation.

CAUTION

Do not connect the REF1 pin or the REF2 pin to any voltage source lower than GND or higher than V_S .

The output voltage is set by applying a voltage or voltages to the reference voltage inputs, REF1 and REF2. The reference inputs are connected to an internal gain network. There is no operational difference between the two reference pins.



图 33. Adjusting the Output Midpoint

8.4.2 Reference Pin Connections for Unidirectional Current Measurements

Unidirectional operation allows current measurements through a resistive shunt in one direction. For unidirectional operation, connect the device reference pins together and then to the negative rail (see the [Ground Referenced Output](#) section). The required differential input polarity depends on the output voltage setting. The amplifier output moves away from the referenced rail proportional to the current passing through the internal shunt resistor.

8.4.3 Ground Referenced Output

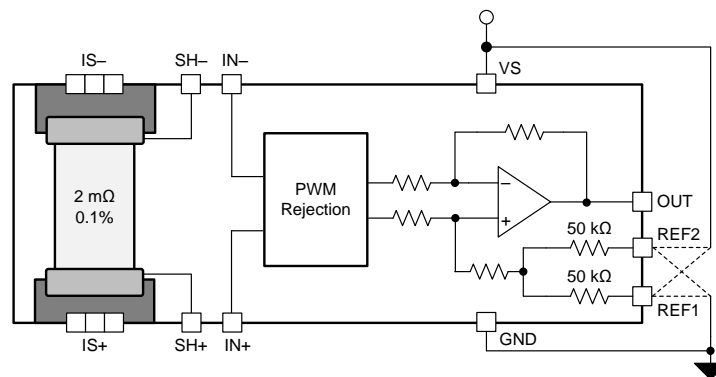
When using the INA253 in unidirectional mode with a ground-referenced output, both reference inputs are connected to ground. 图 34 shows how this configuration takes the output to ground when there is 0-A flowing across the internal shunt.



图 34. Ground-Referenced Output

Device Functional Modes (接下页)

8.4.4 Reference Pin Connections for Bidirectional Current Measurements

Bidirectional operation allows the INA253 to measure currents through a resistive shunt in two directions. For this case, set the output voltage anywhere within the reference input limits. A common configuration is to set the reference inputs at half-scale for equal range in both directions. However, the reference inputs can be set to a voltage other than half-scale when the bidirectional current is nonsymmetrical.

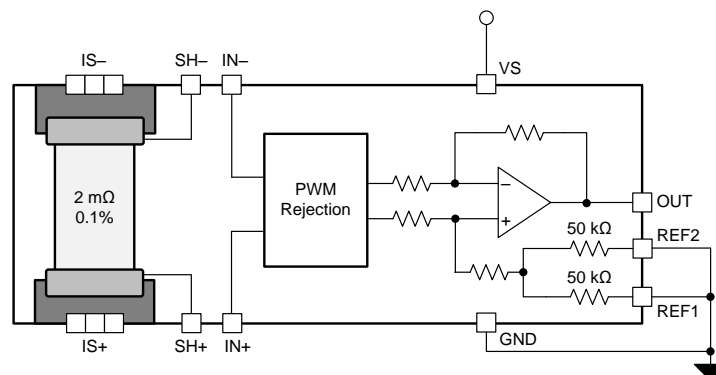
8.4.4.1 Output Set to External Reference Voltage

Connecting both pins together and then to a reference voltage results in an output voltage equal to the reference voltage for the condition of shorted input pins or a 0-V differential input. 图 35 shows this configuration. The output voltage decreases below the reference voltage when the IN+ pin is negative relative to the IN- pin, and increases when the IN+ pin is positive relative to the IN- pin. This technique is the most accurate way to bias the output to a precise voltage.



图 35. External Reference Output

8.4.5 Output Set to Mid-Supply Voltage

图 36 shows that by connecting one reference pin to VS and the other to the GND pin, the output is set at half of the supply when there is no differential input. This method creates a ratiometric offset to the supply voltage, where the output voltage remains at $VS / 2$ when 0 V is applied between the IN+ and IN- inputs.

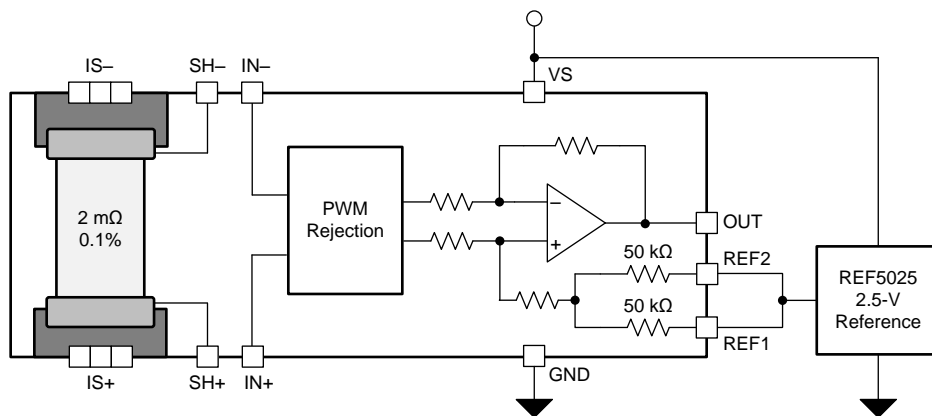

图 36. Mid-Supply Voltage Output

Device Functional Modes (接下页)

8.4.6 Output Set to Mid-External Reference

In this example, an external reference is divided by two by connecting one REF pin to ground and the other REF pin to the reference, as shown in 图 37.

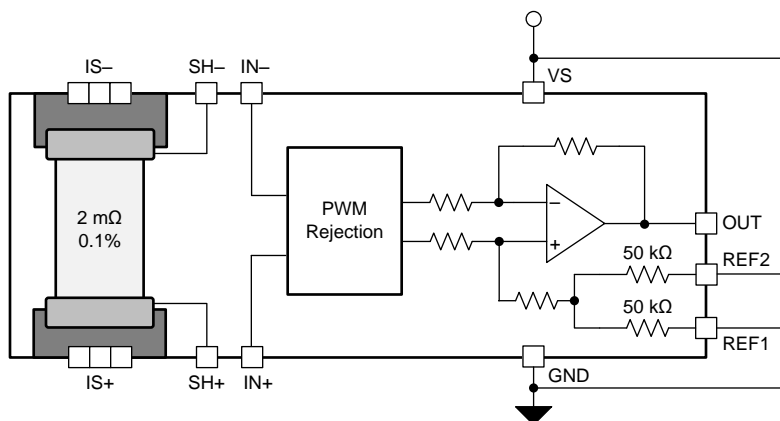

图 37. Mid-External Reference Output

8.4.7 Output Set Using Resistor Divide

The INA253 REF1 and REF2 pins allow for the midpoint of the output voltage to be adjusted for system circuitry connections to analog to digital converters (ADCs) or other amplifiers. The REF pins are designed to be connected directly to supply, ground, or a low-impedance reference voltage. The REF pins can be connected together and biased using a resistor divider to achieve a custom output voltage. If the amplifier is used in this configuration, as shown in 图 38, use the output as a differential signal with respect to the resistor divider voltage. For most accurate results, do not use single-ended measurements at the amplifier output because the internal impedance shifts can adversely affect device performance specifications.

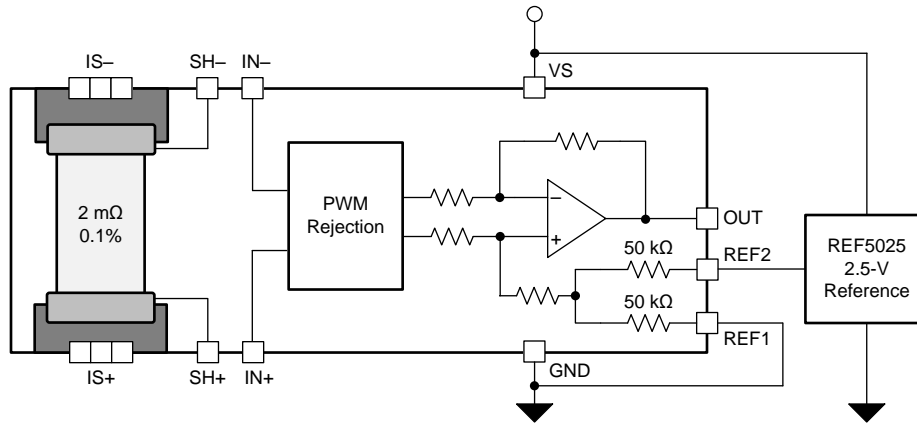

图 38. Setting the Reference Using a Resistor Divider

9 Application and Implementation

注

Information in the following applications sections is not part of the TI component specification, and TI does not warrant its accuracy or completeness. TI's customers are responsible for determining suitability of components for their purposes. Customers should validate and test their design implementation to confirm system functionality.

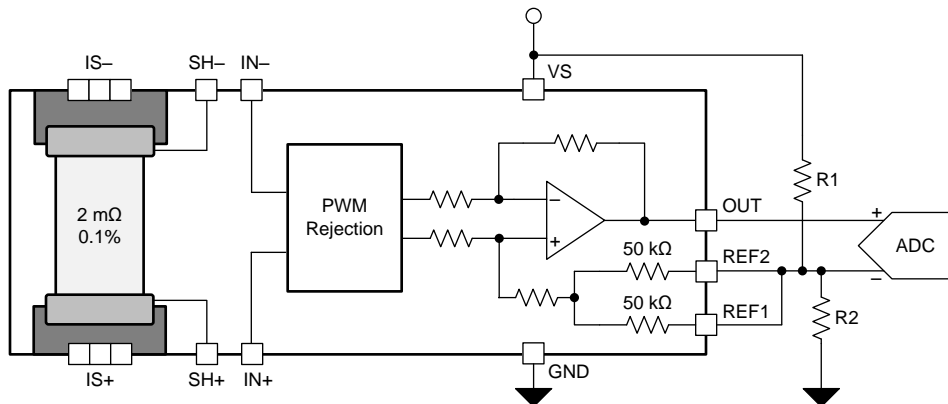
9.1 Application Information

The INA253 measures the voltage developed as current flows across the integrated low inductive current-sensing resistor. The device provides reference pins to configure operation as either unidirectional or bidirectional output swing. When using the INA253 for inline motor current sense or measuring current in an h-bridge, the device is commonly configured for bidirectional operation.

9.1.1 Input Filtering

注

Input filters are not required for accurate measurements using the INA253. For most accurate results, do not use filters at the IN+ and IN- inputs. However, if filter components are used on the input of the amplifier, follow the guidelines in this section to minimize effects on performance.

Based strictly on user design requirements, external filtering of the current signal may be desired. The initial location that can be considered for the filter is at the output of the current amplifier. Although placing the filter at the output satisfies the filtering requirements, this location changes the low output impedance measured by any circuitry connected to the output voltage pin. The other location for filter placement is at the current amplifier input pins. This location also satisfies the filtering requirement, but carefully select the components to minimize the impact on device performance. 图 39 shows a filter placed at the inputs pins.



图 39. Filter at Input Pins

External series resistance provides a source of additional measurement error. Therefore, keep the value of these series resistors to 10-Ω or less in order to reduce loss of accuracy. The internal bias network shown in 图 39 creates a mismatch in input bias currents when a differential voltage is applied between the input pins (see 图 40). If additional external series filter resistors are added to the circuit, a mismatch is created in the voltage drop across the filter resistors. This voltage is a differential error voltage in the shunt resistor voltage. In addition to the absolute resistor value, mismatch resulting from resistor tolerance can significantly impact the error because this value is calculated based on the actual measured resistance.

Application Information (接下页)

图 40. Input Bias Current vs Differential Input Voltage

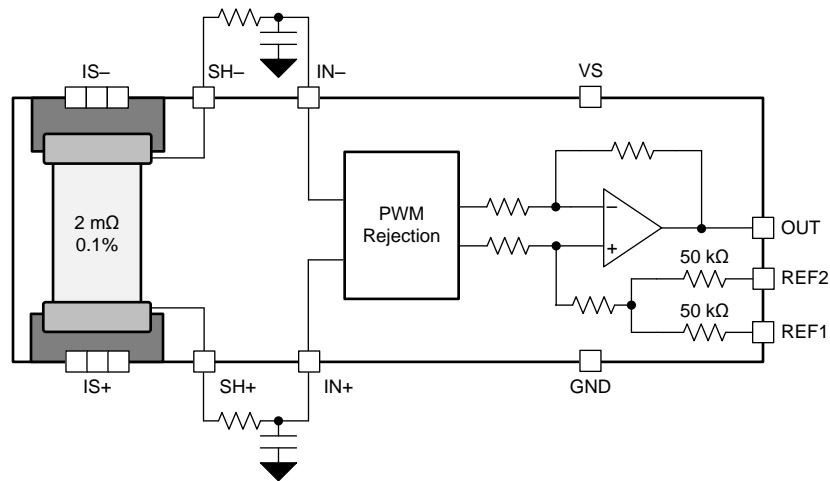
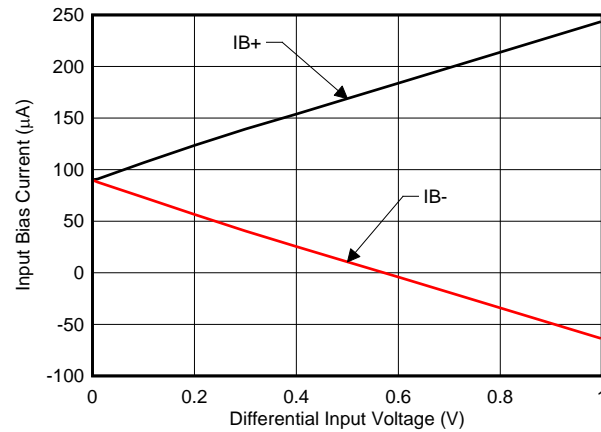
Calculate the measurement error expected from the additional external filter resistors using [公式 1](#).

$$\text{Gain Error (\%)} = 100 - (100 \times \text{Gain Error Factor})$$

where

- Gain Error Factor is calculated using [公式 2](#). (1)

$$\text{Gain Error Factor} = \frac{3000}{R_S + 3000}$$

Where:

- R_S is the external filter resistance value (2)

Calculate the gain error factor, shown in [公式 2](#), in order to determine the gain error introduced by the additional external series resistance. [公式 1](#) calculates the deviation of the shunt voltage resulting from the attenuation and imbalance created by the added external filter resistance. [表 1](#) provides the gain error factor and gain error for several resistor values.

表 1. Gain Error Factor and Gain Error for External Input Resistors

EXTERNAL RESISTANCE (Ω)	GAIN ERROR FACTOR	GAIN ERROR (%)
5	0.998	0.17
10	0.997	0.33
100	0.968	3.23

9.2 Typical Applications

The INA253 offers advantages for multiple applications including the following:

- High common-mode range and excellent CMRR enables direct inline sensing
- Precision low-inductive, low-drift shunt eliminates the need for overtemperature system calibration
- Ultra-low offset and drift eliminates the necessity of calibration
- Wide supply range enables a direct interface with most microprocessors

9.2.1 High-Side, High-Drive, Solenoid Current-Sense Application

Challenges exist in solenoid drive current sensing that are similar to those in motor inline current sensing. In certain topologies, the current-sensing amplifier is exposed to the full-scale PWM voltage between ground and supply. The INA253 is an excellent choice for this type of application. The 2-mΩ integrated shunt with a total system accuracy of 0.2% with a total system drift of 25 ppm/°C provides system accuracy across temperature eliminating the need for tri temperature system calibration.



图 41. Solenoid Drive Application Circuit

9.2.1.1 Design Requirements

For this application, the INA253 measures current in the driver circuit of a 12-V, 500-mA hydraulic valve.

表 2. Design Parameters

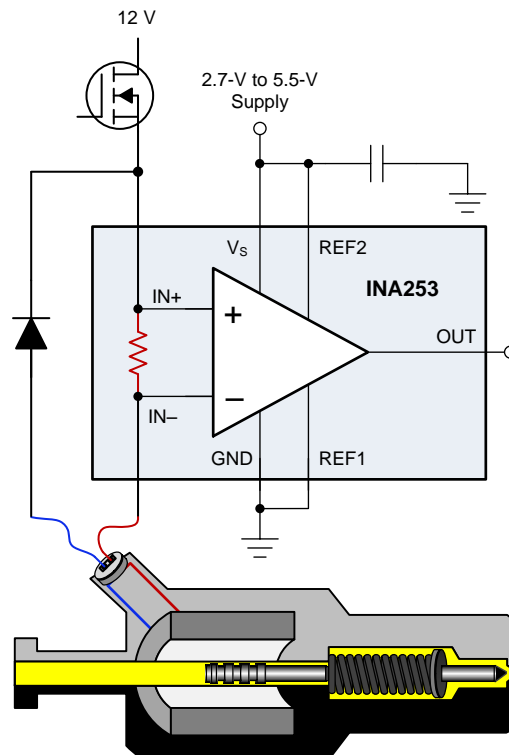
DESIGN PARAMETER	EXAMPLE VALUE
Common-mode voltage	12 V
Maximum sense current	500 mA
Power-supply voltage	3.3 V

9.2.1.2 Detailed Design Procedure

To demonstrate the performance of the device, the INA253, with a gain of 400mV/A, is selected for this design and powered from a 5-V supply.

Using the information in the [Output Set to Mid-Supply Voltage](#) section, the reference point is set to midscale by splitting the supply with REF1 connected to ground and REF2 connected to supply. Alternatively, the reference pins can be tied together and driven with an external precision reference.

9.2.1.3 Application Curve



图 42. Solenoid Drive Current Sense Input and Output Signals

9.2.2 Speaker Enhancements and Diagnostics Using Current Sense Amplifier

CLASS-D audio amplifiers in conjunction with the INA253 provide accurate speaker load current. Speaker load current is used to determine speaker diagnostics, and can further be expanded to measure key speaker parameters, such as speaker coil resistance and speaker real-time ambient temperature.

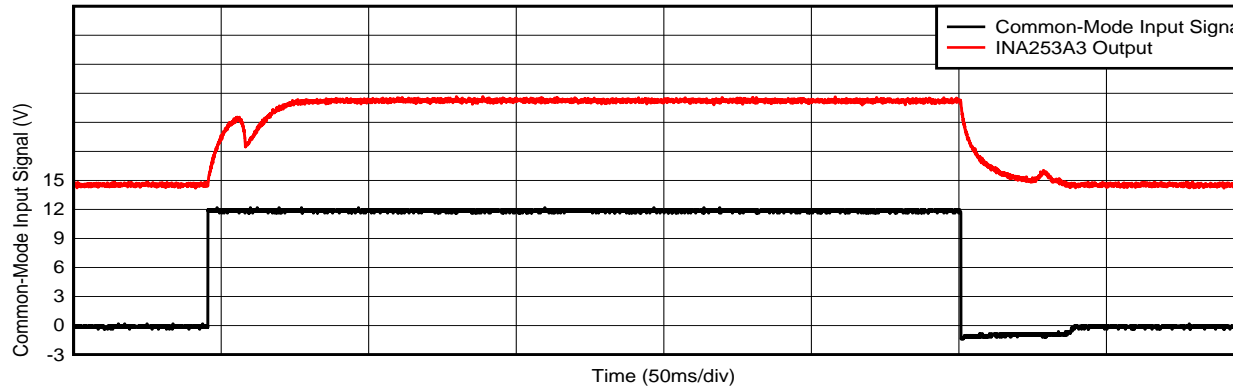

图 43. Current Sensing in a CLASS-D Subsystem

9.2.2.1 Design Requirements

表 3. Design Parameters

DESIGN PARAMETER	EXAMPLE VALUE
Common-mode voltage	24 V
Power-supply voltage	5 V
Maximum rms current	5 A
Frequency sweep	20 Hz to 20 KHz

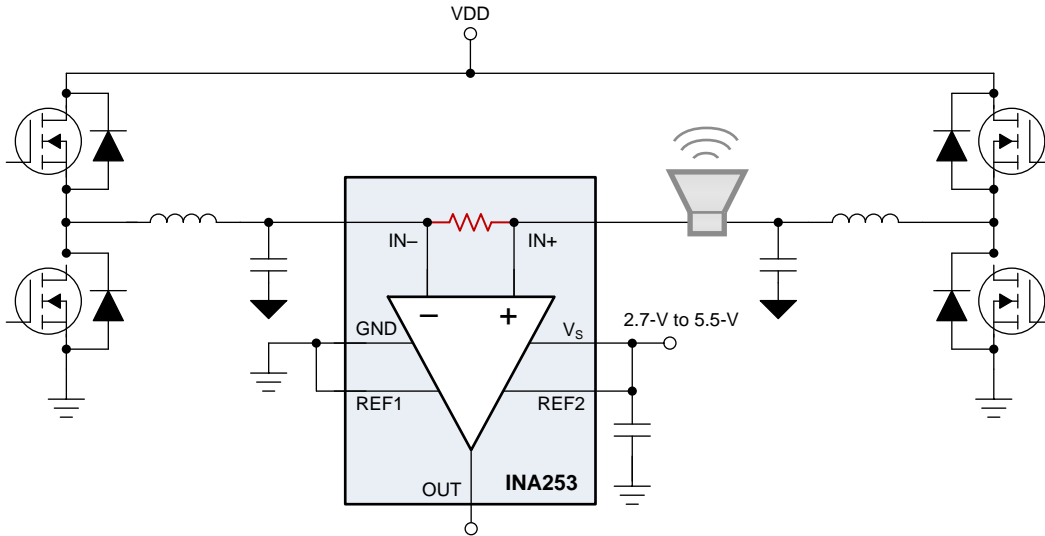
9.2.2.2 Detailed Design Procedure

For this application, the INA253 measures current flowing through the speaker from the CLASS-D amplifier. The integrated shunt of 2 mΩ with an inductance of only 3 nH is an excellent choice for current sensing in speaker applications where low inductance is required. The low-inductive shunt enables accurate current sensing across frequencies over the audio range of 20 hz to 20 kHz.

The INA253 is setup in a bidirectional with the reference set to mid-supply as shown in 图 37. The power supply to INA253 is setup at 5 V. The output of INA253 is set at 2.5 V. The INA253 with a gain of 100 mV/A, the INA253 output for a peak to peak of 10-A current the output of the INA253 will swing from 3.5 V to 1.5 V. The output can be directly connected to ADC input that has a full scale range of 5 V. The INA253 has a low THD+N of 0.1% at 1 kHz that enables distortion measurement of speaker. The INA253 can measure the impedance of the speaker and accurately measure the resonance frequency and peak impedance at resonance frequency. The INA253 can accurately track changes in impedance real time.

9.2.2.3 Application Curve

A typical example output response of speaker of 4-Ω impedance measurement from 20 Hz to 20 kHz is as shown in 图 44.



图 44. Speaker Impedance Measurement

9.2.3 Current Sensing for Remote I/Os in PLC

In industrial remote IOs, there is often one power supply for several ports, as shown in Figure 45. For example, an IO-Link master has one power supply of 24 V 5 A, but eight IO-Link ports, where each port can deliver up to 1 A. The IO-Link master must measure the total current to make sure in order to not overload the power supply. To prevent from overloading the system, each port is only turned on if sufficient headroom in the total system current is available. Figure 45 shows the block diagram of such a system. This example is implemented on TI reference design TIDA-010016. The INA253 is an excellent choice for this design because this device is simple to use, and delivers high accuracy over a wide temperature range. The integrated 2-mΩ shunt has a low voltage drop and therefore low power dissipation.

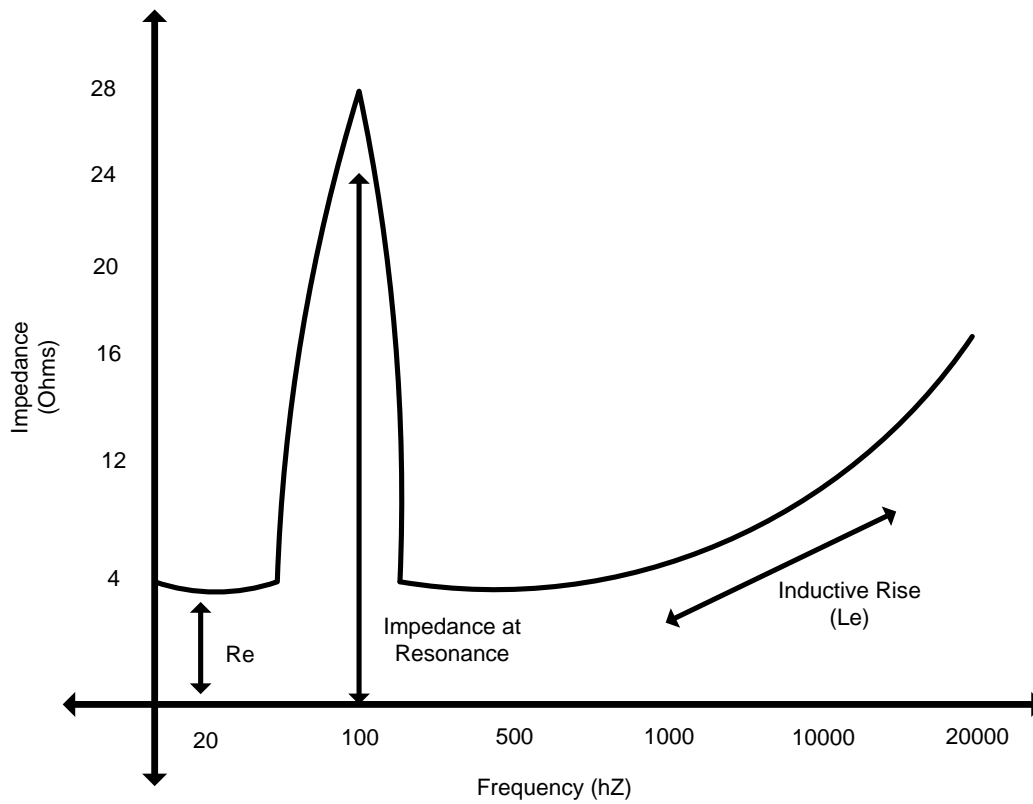

图 45. Current Sensing in Remote I/O

9.2.3.1 Design Requirements

表 4. Design Parameters

DESIGN PARAMETER	EXAMPLE VALUE
Common-mode voltage	24 V
Maximum current	9 A
ADC input voltage	1.8 V
Supply voltage	3.3 V

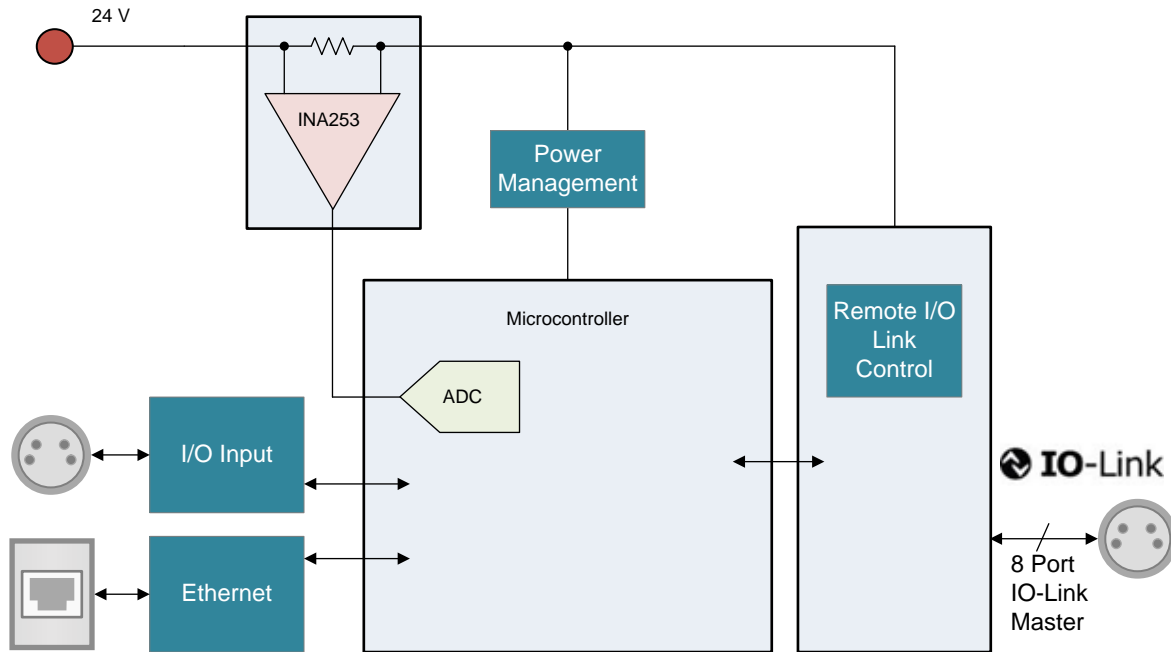
In this design, the current flow is unidirectional; therefore, the REF inputs must be tied to GND. Because of the given ADC input range and current, the 200-mV/A version is chosen.

9.2.3.2 Application Curve

A typical response of INA253 in a remote I/O application is shown in [图 46](#). The common-mode voltage steps from 0 V to 24 V, and the current output across the 24 V power supply is measured using the INA253.



图 46. INA253 Current Sense Output Response in Remote I/O

10 Power Supply Recommendations

The INA253 makes accurate measurements beyond the connected power-supply voltage (V_S) because the inputs (IN+ and IN-) operate anywhere between -4 V and $+80\text{ V}$, independent of V_S . For example, the V_S power supply equals 5 V and the common-mode voltage of the measured shunt can be as high as 80 V . Although the common-mode voltage of the input can be beyond the supply voltage, the output voltage range of the INA253 is constrained to the supply voltage.

Place the power-supply bypass capacitor as close as possible to the supply and ground pins. The recommended value of this bypass capacitor is $0.1\text{ }\mu\text{F}$. Additional decoupling capacitance can be added to compensate for noisy or high-impedance power supplies. If the INA253 output is set to mid-supply, then take extreme care to minimize noise on the power supply.

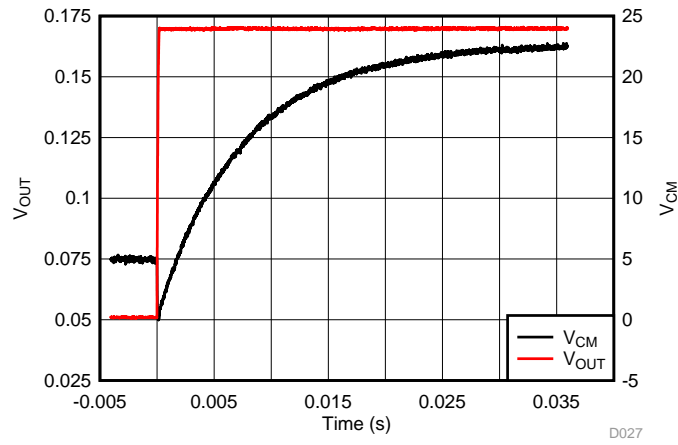
11 Layout

11.1 Layout Guidelines

- This device is specified for current handling of up to 10 A over the entire -40°C to $+125^\circ\text{C}$ temperature range using a 1-oz copper pour for the input power plane, as well as no external airflow passing over the device.
- The primary current-handling limitation for this device is how much heat is dissipated inside the package. Efforts to improve heat transfer out of the package and into the surrounding environment improve the ability of the device to handle currents of up to 15 A over the entire -40°C to $+125^\circ\text{C}$ temperature range.
- Heat transfer improvements primarily involve larger copper power traces and planes with increased copper thickness (2 oz), as well as providing airflow to pass over the device. The INA253 evaluation module (EVM) features a 2-oz copper pour for the planes, and is capable of supporting 15 A at temperatures up to 125°C .
- Place the power-supply bypass capacitor as close as possible to the supply and ground pins. The recommended value of this bypass capacitor is $0.1\text{ }\mu\text{F}$. Additional decoupling capacitance can be added to compensate for noisy or high-impedance power supplies.

11.2 Layout Example



图 47. INA253 Layout Example

12 器件和文档支持

12.1 器件支持

12.1.1 开发支持

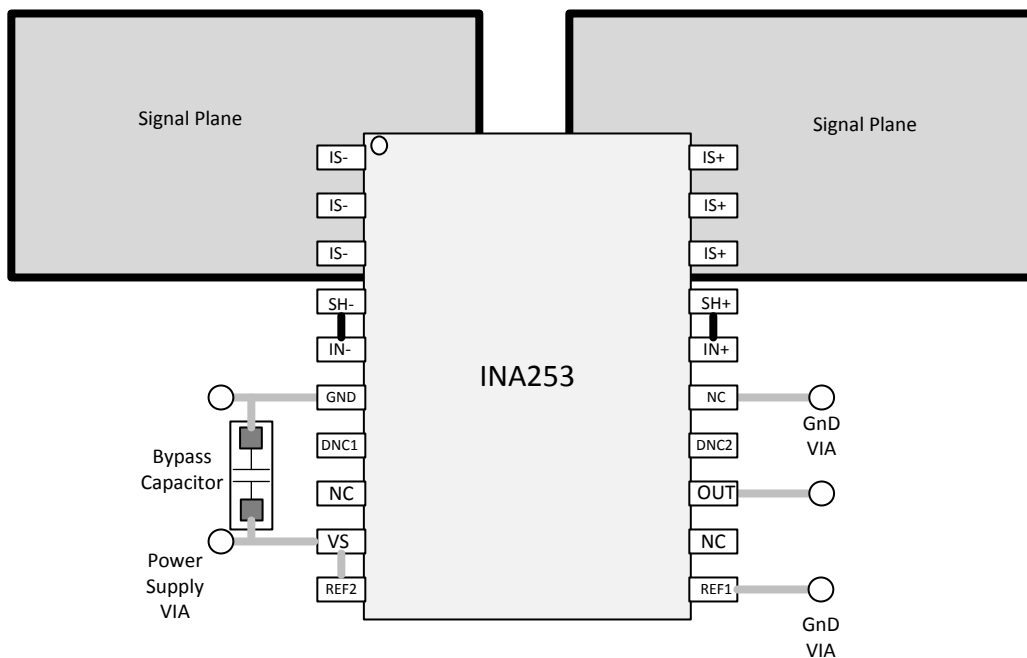
[INA253 评估模块 \(EVM\)](#)

12.2 相关文档

请参阅如下相关文档: [《INA253EVM 用户指南》](#)

12.3 接收文档更新通知

要接收文档更新通知, 请导航至 TI.com.cn 上的器件产品文件夹。单击右上角的通知我进行注册, 即可每周接收产品信息更改摘要。有关更改的详细信息, 请查看任何已修订文档中包含的修订历史记录。

12.4 社区资源

下列链接提供到 TI 社区资源的连接。链接的内容由各个分销商“按照原样”提供。这些内容并不构成 TI 技术规范, 并且不一定反映 TI 的观点; 请参阅 TI 的 [《使用条款》](#)。

TI E2E™ 在线社区 [TI 的工程师对工程师 \(E2E\) 社区](#)。此社区的创建目的在于促进工程师之间的协作。在 e2e.ti.com 中, 您可以咨询问题、分享知识、拓展思路并与同行工程师一道帮助解决问题。

设计支持 [TI 参考设计支持](#) 可帮助您快速查找有帮助的 E2E 论坛、设计支持工具以及技术支持的联系信息。

12.5 商标

E2E is a trademark of Texas Instruments.
All other trademarks are the property of their respective owners.

12.6 静电放电警告



ESD 可能会损坏该集成电路。德州仪器 (TI) 建议通过适当的预防措施处理所有集成电路。如果不遵守正确的处理措施和安装程序, 可能会损坏集成电路。

ESD 的损坏小至导致微小的性能降级, 大至整个器件故障。精密的集成电路可能更容易受到损坏, 这是因为非常细微的参数更改都可能会导致器件与其发布的规格不相符。

12.7 术语表

[SLYZ022](#) — *TI* 术语表。

这份术语表列出并解释术语、缩写和定义。

13 机械、封装和可订购信息

以下页面包含机械、封装和可订购信息。这些信息是指定器件的最新可用数据。数据如有变更, 恕不另行通知, 且不会对此文档进行修订。如需获取此数据表的浏览器版本, 请查阅左侧的导航栏。

PACKAGING INFORMATION

Orderable Device	Status (1)	Package Type	Package Drawing	Pins	Package Qty	Eco Plan (2)	Lead finish/ Ball material (6)	MSL Peak Temp (3)	Op Temp (°C)	Device Marking (4/5)	Samples
INA253A1IPW	ACTIVE	TSSOP	PW	20	70	RoHS & Green	NIPDAU	Level-2-260C-1 YEAR	-40 to 125	I253A1	Samples
INA253A1IPWR	ACTIVE	TSSOP	PW	20	2000	RoHS & Green	NIPDAU	Level-2-260C-1 YEAR	-40 to 125	I253A1	Samples
INA253A2IPW	ACTIVE	TSSOP	PW	20	70	RoHS & Green	NIPDAU	Level-2-260C-1 YEAR	-40 to 125	I253A2	Samples
INA253A2IPWR	ACTIVE	TSSOP	PW	20	2000	RoHS & Green	NIPDAU	Level-2-260C-1 YEAR	-40 to 125	I253A2	Samples
INA253A3IPW	ACTIVE	TSSOP	PW	20	70	RoHS & Green	NIPDAU	Level-2-260C-1 YEAR	-40 to 125	I253A3	Samples
INA253A3IPWR	ACTIVE	TSSOP	PW	20	2000	RoHS & Green	NIPDAU	Level-2-260C-1 YEAR	-40 to 125	I253A3	Samples

(1) The marketing status values are defined as follows:

ACTIVE: Product device recommended for new designs.

LIFEBUY: TI has announced that the device will be discontinued, and a lifetime-buy period is in effect.

NRND: Not recommended for new designs. Device is in production to support existing customers, but TI does not recommend using this part in a new design.

PREVIEW: Device has been announced but is not in production. Samples may or may not be available.

OBSOLETE: TI has discontinued the production of the device.

(2) **RoHS:** TI defines "RoHS" to mean semiconductor products that are compliant with the current EU RoHS requirements for all 10 RoHS substances, including the requirement that RoHS substance do not exceed 0.1% by weight in homogeneous materials. Where designed to be soldered at high temperatures, "RoHS" products are suitable for use in specified lead-free processes. TI may reference these types of products as "Pb-Free".

RoHS Exempt: TI defines "RoHS Exempt" to mean products that contain lead but are compliant with EU RoHS pursuant to a specific EU RoHS exemption.

Green: TI defines "Green" to mean the content of Chlorine (Cl) and Bromine (Br) based flame retardants meet JS709B low halogen requirements of <=1000ppm threshold. Antimony trioxide based flame retardants must also meet the <=1000ppm threshold requirement.

(3) MSL, Peak Temp. - The Moisture Sensitivity Level rating according to the JEDEC industry standard classifications, and peak solder temperature.

(4) There may be additional marking, which relates to the logo, the lot trace code information, or the environmental category on the device.

(5) Multiple Device Markings will be inside parentheses. Only one Device Marking contained in parentheses and separated by a "~" will appear on a device. If a line is indented then it is a continuation of the previous line and the two combined represent the entire Device Marking for that device.

(6) Lead finish/Ball material - Orderable Devices may have multiple material finish options. Finish options are separated by a vertical ruled line. Lead finish/Ball material values may wrap to two lines if the finish value exceeds the maximum column width.

Important Information and Disclaimer: The information provided on this page represents TI's knowledge and belief as of the date that it is provided. TI bases its knowledge and belief on information provided by third parties, and makes no representation or warranty as to the accuracy of such information. Efforts are underway to better integrate information from third parties. TI has taken and continues to take reasonable steps to provide representative and accurate information but may not have conducted destructive testing or chemical analysis on incoming materials and chemicals. TI and TI suppliers consider certain information to be proprietary, and thus CAS numbers and other limited information may not be available for release.

In no event shall TI's liability arising out of such information exceed the total purchase price of the TI part(s) at issue in this document sold by TI to Customer on an annual basis.

TAPE AND REEL INFORMATION

QUADRANT ASSIGNMENTS FOR PIN 1 ORIENTATION IN TAPE



*All dimensions are nominal

Device	Package Type	Package Drawing	Pins	SPQ	Reel Diameter (mm)	Reel Width W1 (mm)	A0 (mm)	B0 (mm)	K0 (mm)	P1 (mm)	W (mm)	Pin1 Quadrant
INA253A1IPWR	TSSOP	PW	20	2000	330.0	16.4	6.95	7.0	1.4	8.0	16.0	Q1
INA253A2IPWR	TSSOP	PW	20	2000	330.0	16.4	6.95	7.0	1.4	8.0	16.0	Q1
INA253A3IPWR	TSSOP	PW	20	2000	330.0	16.4	6.95	7.0	1.4	8.0	16.0	Q1

TAPE AND REEL BOX DIMENSIONS

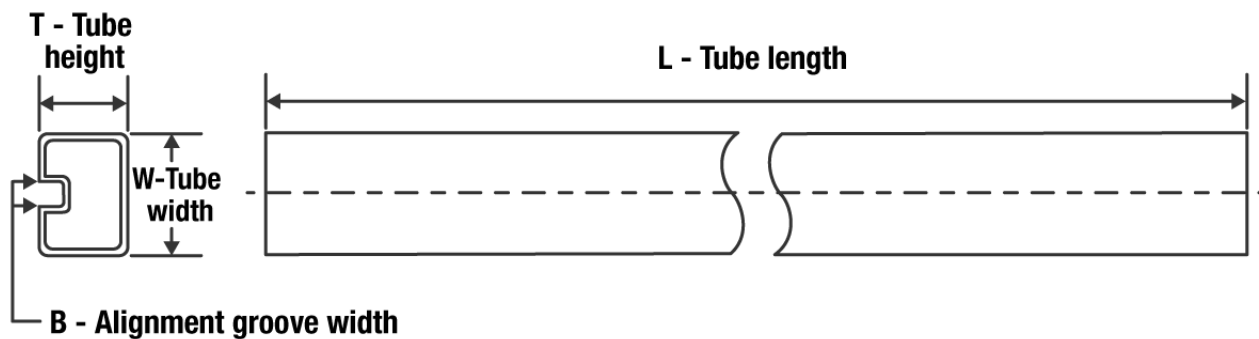

*All dimensions are nominal

Device	Package Type	Package Drawing	Pins	SPQ	Length (mm)	Width (mm)	Height (mm)
INA253A1IPWR	TSSOP	PW	20	2000	853.0	449.0	35.0
INA253A2IPWR	TSSOP	PW	20	2000	853.0	449.0	35.0
INA253A3IPWR	TSSOP	PW	20	2000	853.0	449.0	35.0

TUBE

*All dimensions are nominal

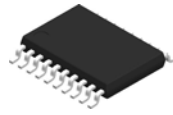
Device	Package Name	Package Type	Pins	SPQ	L (mm)	W (mm)	T (μm)	B (mm)
INA253A1IPW	PW	TSSOP	20	70	530	10.2	3600	3.5
INA253A2IPW	PW	TSSOP	20	70	530	10.2	3600	3.5
INA253A3IPW	PW	TSSOP	20	70	530	10.2	3600	3.5



4220206/A 02/2017

NOTES:

1. All linear dimensions are in millimeters. Any dimensions in parenthesis are for reference only. Dimensioning and tolerancing per ASME Y14.5M.
2. This drawing is subject to change without notice.
3. This dimension does not include mold flash, protrusions, or gate burrs. Mold flash, protrusions, or gate burrs shall not exceed 0.15 mm per side.
4. This dimension does not include interlead flash. Interlead flash shall not exceed 0.25 mm per side.
5. Reference JEDEC registration MO-153.

EXAMPLE BOARD LAYOUT

PW0020A

TSSOP - 1.2 mm max height

SMALL OUTLINE PACKAGE



LAND PATTERN EXAMPLE
EXPOSED METAL SHOWN
SCALE: 10X



SOLDER MASK DETAILS

4220206/A 02/2017

NOTES: (continued)

- 6. Publication IPC-7351 may have alternate designs.
- 7. Solder mask tolerances between and around signal pads can vary based on board fabrication site.

EXAMPLE STENCIL DESIGN

PW0020A

TSSOP - 1.2 mm max height

SMALL OUTLINE PACKAGE



SOLDER PASTE EXAMPLE
BASED ON 0.125 mm THICK STENCIL
SCALE: 10X

4220206/A 02/2017

NOTES: (continued)

8. Laser cutting apertures with trapezoidal walls and rounded corners may offer better paste release. IPC-7525 may have alternate design recommendations.
9. Board assembly site may have different recommendations for stencil design.

重要声明和免责声明

TI“按原样”提供技术和可靠性数据（包括数据表）、设计资源（包括参考设计）、应用或其他设计建议、网络工具、安全信息和其他资源，不保证没有瑕疵且不做任何明示或暗示的担保，包括但不限于对适销性、某特定用途方面的适用性或不侵犯任何第三方知识产权的暗示担保。

这些资源可供使用 TI 产品进行设计的熟练开发人员使用。您将自行承担以下全部责任：(1) 针对您的应用选择合适的 TI 产品，(2) 设计、验证并测试您的应用，(3) 确保您的应用满足相应标准以及任何其他功能安全、信息安全、监管或其他要求。

这些资源如有变更，恕不另行通知。TI 授权您仅可将这些资源用于研发本资源所述的 TI 产品的应用。严禁对这些资源进行其他复制或展示。您无权使用任何其他 TI 知识产权或任何第三方知识产权。您应全额赔偿因在这些资源的使用中对 TI 及其代表造成的任何索赔、损害、成本、损失和债务，TI 对此概不负责。

TI 提供的产品受 [TI 的销售条款](#) 或 [ti.com](#) 上其他适用条款/TI 产品随附的其他适用条款的约束。TI 提供这些资源并不会扩展或以其他方式更改 TI 针对 TI 产品发布的适用的担保或担保免责声明。

TI 反对并拒绝您可能提出的任何其他或不同的条款。

邮寄地址：Texas Instruments, Post Office Box 655303, Dallas, Texas 75265

Copyright © 2022，德州仪器 (TI) 公司