

## THS4532 超低功耗、轨到轨输出、全差分放大器

### 1 特性

- 超低功耗：
  - 电压：2.5V 至 5.5V
  - 电流：250 $\mu$ A
  - 省电模式：0.5 $\mu$ A（典型值）
- 全差分架构
- 带宽：36MHz
- 转换速率：200V/ $\mu$ s
- 总谐波失真 (THD)：1kHz (1V<sub>RMS</sub>, R<sub>L</sub>=2k $\Omega$ ) 时为 -120dBc
- 输入电压噪声：10nV/ $\sqrt{\text{Hz}}$ (f=1kHz)
- 高 DC 精度：
  - V<sub>OS</sub>:  $\pm$ 100 $\mu$ V
  - V<sub>OS</sub>漂移:  $\pm$ 3 $\mu$ V/ $^{\circ}$ C (-40 $^{\circ}$ C 至 +125 $^{\circ}$ C)
  - A<sub>OL</sub>: 114dB
- 轨到轨输出 (RRO)
- 负电源轨输入 (NRI)
- 输出共模控制

### 2 应用

- 低功耗逐次逼近 (SAR)，三角积分模数转换器 (ADC) 驱动器
- 低功耗、高性能：
  - 差分到差分放大器
  - 单端到差分放大器
- 低功耗、宽带宽差分驱动器
- 低功耗、宽带宽差分信号调节
- 高通道数和高功率密度系统

### 3 说明

THS4532 是一款低功耗、全差分放大器，其具有低于负电源轨的输入共模范围以及轨到轨输出。此器件设计用于能耗和功率耗散都十分关键的低功率数据采集系统和高密度应用。

此器件特有精确输出共模控制，此控制可实现驱动模数转换器 (ADC) 时的 dc 耦合。与低于负电源轨和轨到轨输出的输入共模范围相耦合，此控制可只使用 2.5V 至 5V 的单电源轻松实现单端接地基准信号源与逐次逼近 (SAR) 的连接和三角积分 ( $\Delta\Sigma$ ) ADC 的对接。

THS4532 也是一款适用于通用、低功耗差分信号调节应用的实用工具。

该器件在 -40 $^{\circ}$ C 至 125 $^{\circ}$ C 的扩展级工业温度范围内额定运行。该器件提供以下封装选项：

#### 器件信息<sup>(1)</sup>

器件型号	封装	封装尺寸 (标称值)
THS4532	TSSOP	5.00mm x 4.40mm

(1) 如需了解所有可用封装，请见数据表末尾的可订购产品附录。

音频分析仪中的 1kHz 快速傅里叶变换 (FFT) 图

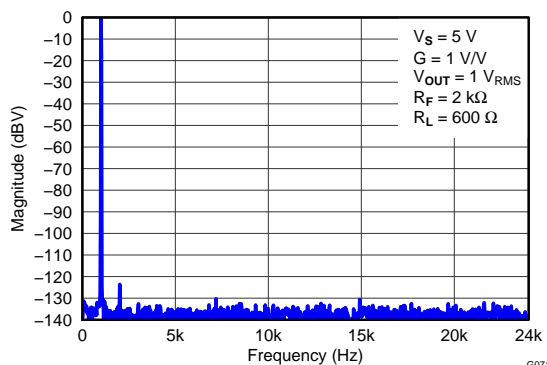

## 目录

<ul style="list-style-type: none"> <li>1 特性 ..... 1</li> <li>2 应用 ..... 1</li> <li>3 说明 ..... 1</li> <li>4 修订历史记录 ..... 2</li> <li>5 <b>Related Products</b> ..... 3</li> <li>6 <b>Pin Configuration and Functions</b> ..... 4</li> <li>7 <b>Specifications</b> ..... 5           <ul style="list-style-type: none"> <li>7.1 Absolute Maximum Ratings ..... 5</li> <li>7.2 ESD Ratings ..... 5</li> <li>7.3 Recommended Operating Conditions ..... 5</li> <li>7.4 Thermal Information ..... 5</li> <li>7.5 Electrical Characteristics: <math>V_S = 2.7\text{ V}</math> ..... 6</li> <li>7.6 Electrical Characteristics: <math>V_S = 5\text{ V}</math> ..... 9</li> <li>7.7 Typical Characteristics ..... 12</li> </ul> </li> <li>8 <b>Detailed Description</b> ..... 25           <ul style="list-style-type: none"> <li>8.1 Overview ..... 25</li> <li>8.2 Functional Block Diagram ..... 25</li> </ul> </li> </ul>	<ul style="list-style-type: none"> <li>8.3 Feature Description ..... 25</li> <li>8.4 Device Functional Modes ..... 28</li> <li>9 <b>Application and Implementation</b> ..... 29           <ul style="list-style-type: none"> <li>9.1 Application Information ..... 29</li> <li>9.2 Typical Applications ..... 37</li> <li>9.3 Systems Examples ..... 41</li> </ul> </li> <li>10 <b>Power Supply Recommendations</b> ..... 47</li> <li>11 <b>Layout</b> ..... 48           <ul style="list-style-type: none"> <li>11.1 Layout Guidelines ..... 48</li> <li>11.2 Layout Example ..... 49</li> </ul> </li> <li>12 器件和文档支持 ..... 53           <ul style="list-style-type: none"> <li>12.1 文档支持 ..... 53</li> <li>12.2 社区资源 ..... 53</li> <li>12.3 商标 ..... 53</li> <li>12.4 静电放电警告 ..... 53</li> <li>12.5 Glossary ..... 53</li> </ul> </li> <li>13 机械、封装和可订购信息 ..... 53</li> </ul>
--	---

## 4 修订历史记录

NOTE: Page numbers for previous revisions may differ from page numbers in the current version.

Changes from Original (February 2013) to Revision A	Page
• 已添加 ESD 额定值表, 建议运行条件, 详细说明部分, 特性描述部分, 器件功能模式部分以及应用和实施部分。电源相关建议部分, 布局部分, 器件和文档支持部分以及机械、封装和可订购信息部分 .....	1
• Changed $V_{OCM} = \text{open To: } V_{OCM} = +V_S/2$ in the test conditions of <i>Electrical Characteristics: <math>V_S = 2.7\text{ V}</math></i> .....	6
• Added Note 3 to the <i>Electrical Characteristics: <math>V_S = 2.7\text{ V}</math></i> table. ....	7
• Changed $V_{OCM} = \text{open To: } V_{OCM} = +V_S/2$ in the test conditions of <i>Electrical Characteristics: <math>V_S = 5\text{ V}</math></i> .....	9
• Changed <i>Typical Characteristics: <math>V_S = 2.7\text{ V}</math></i> Conditions deleted text "Channel 1" .....	13
• Changed <i>Typical Characteristics: <math>V_S = 5\text{ V}</math></i> Conditions deleted text "Channel 1" .....	19

## 5 Related Products

**Table 1. Related Amplifiers**

DEVICE	BW (MHz)	I <sub>Q</sub> (mA)	THD (dBc) at 100 kHz	V <sub>N</sub> (nV/√Hz)	RAIL-TO-RAIL	DUAL PART NUMBERS
<a href="#">THS4531</a>	36	0.25	–104	10	Negative In, Out	<a href="#">THS4532</a>
<a href="#">THS4121</a>	100	16	–79	5.4	Out	
<a href="#">THS4521</a>	145	1.14	–120	4.6	Negative In, Out	<a href="#">THS4522</a>
<a href="#">THS4131</a>	150	16	–107	1.3	No	
<a href="#">THS4520</a>	620	14.2	–107	2	Out	
<a href="#">THS4541</a>	850	10.1	–137	2.2	Negative In, Out	

**Table 2. Related Precision ADCs**

DEVICE	BITS	MAX DATA RATE (kSPS)	NOMINAL SUPPLY (V)	NOMINAL I <sub>CC</sub> (mA) MAX CLK RATE	TYPICAL POWER (mW) MAX CLK RATE
<a href="#">ADS8881</a>	18	1000	5	1.1	5.5
<a href="#">ADS8861</a>	16	1000	3.3	1.67	5.3
<a href="#">ADS8321E</a>	16	100	5	0.9	4.5
<a href="#">ADS7945</a>	14	2000	5	2.32	5.8/ch (dual)
<a href="#">ADS7044</a>	12	1000	3	0.3	0.9

## 6 Pin Configuration and Functions

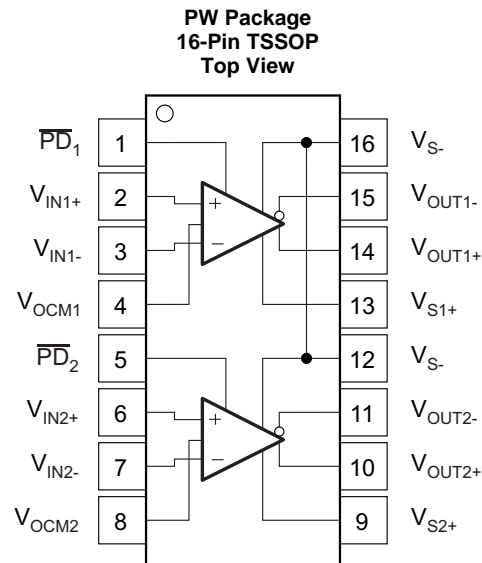

**Pin Functions**

PIN		I/O	DESCRIPTION
NAME	NO.		
$\overline{PD}_1$	1	—	Power-down 1, $\overline{PD}$ = logic low = low power mode, $\overline{PD}$ = logic high = normal operation <b>(PIN MUST BE DRIVEN)</b>
$\overline{PD}_2$	5	—	Amplifier 2 Power-down, $\overline{PD}$ = logic low = low power mode, $\overline{PD}$ = logic high = normal operation <b>(PIN MUST BE DRIVEN)</b>
$V_{IN1+}$	2	I	Noninverting amplifier 1 input
$V_{IN1-}$	3	I	Inverting amplifier 1 input
$V_{IN2+}$	6	I	Noninverting amplifier 2 input
$V_{IN2-}$	7	I	Inverting amplifier 2 input
$V_{OCM1}$	4	I	Common-mode voltage input 1
$V_{OCM2}$	8	I	Common-mode voltage input 2
$V_{OUT1+}$	14	O	Noninverting amplifier 1 output
$V_{OUT1-}$	15	O	Inverting amplifier 1 output
$V_{OUT2+}$	10	O	Noninverting amplifier 2 output
$V_{OUT2-}$	11	O	Inverting amplifier 2 output
$V_{S-}$	12, 16	I	Negative power-supply input. Note $V_{S-}$ tied together on multichannel devices
$V_{S1+}$	13	I	Amplifier 1 positive power-supply input
$V_{S2+}$	9	I	Amplifier 2 positive power-supply input

## 7 Specifications

### 7.1 Absolute Maximum Ratings<sup>(1)</sup>

	MIN	MAX	UNIT
Supply voltage, $V_{S-}$ to $V_{S+}$		5.5	V
Input/output voltage, $V_{IN\pm}$ , $V_{OUT\pm}$ and $V_{OCM}$ pins	$(V_{S-}) - 0.7$	$(V_{S+}) + 0.7$	V
Differential input voltage, $V_{ID}$		1	V
Continuous output current, $I_O$		50	mA
Continuous input current, $I_i$		0.75	mA
Continuous power dissipation	See <a href="#">Thermal Information</a>		
Maximum junction temperature, $T_J$		150	°C
Operating junction temperature, $T_J$	-40	125	°C
Storage temperature, $T_{stg}$	-65	150	°C

- (1) Stresses beyond those listed under *Absolute Maximum Ratings* may cause permanent damage to the device. These are stress ratings only, which do not imply functional operation of the device at these or any other conditions beyond those indicated under *Recommended Operating Conditions*. Exposure to absolute-maximum-rated conditions for extended periods may affect device reliability.

### 7.2 ESD Ratings

		VALUE	UNIT
$V_{(ESD)}$ Electrostatic discharge	Human-body model (HBM), per ANSI/ESDA/JEDEC JS-001 <sup>(1)</sup>	±2500	V
	Charged-device model (CDM), per JEDEC specification JESD22-C101 <sup>(2)</sup>	±500	

- (1) JEDEC document JEP155 states that 500-V HBM allows safe manufacturing with a standard ESD control process.

- (2) JEDEC document JEP157 states that 250-V CDM allows safe manufacturing with a standard ESD control process.

### 7.3 Recommended Operating Conditions

over operating free-air temperature range (unless otherwise noted)

		MIN	NOM	MAX	UNIT
$V_{S+}$	Single-supply voltage	2.7	5	5.4	V
$T_A$	Ambient temperature	-40	25	125	°C

### 7.4 Thermal Information

THERMAL METRIC <sup>(1)</sup>		THS4532	UNIT
		TSSOP (PW)	
		16 PINS	
$R_{\theta JA}$	Junction-to-ambient thermal resistance	122.4	°C/W
$R_{\theta JC(top)}$	Junction-to-case (top) thermal resistance	61.2	
$R_{\theta JB}$	Junction-to-board thermal resistance	66.7	
$\Psi_{JT}$	Junction-to-top characterization parameter	14.4	
$\Psi_{JB}$	Junction-to-board characterization parameter	66.2	
$R_{\theta JC(bot)}$	Junction-to-case (bottom) thermal resistance	N/A	

- (1) For more information about traditional and new thermal metrics, see the *Semiconductor and IC Package Thermal Metrics* application report, [SPRA953](#).

## 7.5 Electrical Characteristics: $V_S = 2.7\text{ V}$

Test conditions at  $T_A = 25^\circ\text{C}$ ,  $V_{S+} = 2.7\text{ V}$ ,  $V_{S-} = 0\text{ V}$ ,  $V_{OCM} = +V_S/2^{(1)}$ ,  $V_{OUT} = 2\text{ V}_{PP}$ ,  $R_F = 2\text{ k}\Omega$ ,  $R_L = 2\text{ k}\Omega$  differential,  $G = 1\text{ V/V}$ , single-ended input, differential output, and input and output referenced to mid-supply, unless otherwise noted.

PARAMETER	TEST CONDITIONS	MIN	TYP	MAX	UNIT	TEST LEVEL <sup>(2)</sup>
<b>AC PERFORMANCE</b>						
Small-signal bandwidth	$V_{OUT} = 100\text{ mV}_{PP}$ , $G = 1$		34		MHz	C
	$V_{OUT} = 100\text{ mV}_{PP}$ , $G = 2$		16			
	$V_{OUT} = 100\text{ mV}_{PP}$ , $G = 5$		6			
	$V_{OUT} = 100\text{ mV}_{PP}$ , $G = 10$		2.7			
Gain-bandwidth product	$V_{OUT} = 100\text{ mV}_{PP}$ , $G = 10$		27		MHz	
Large-signal bandwidth	$V_{OUT} = 2\text{ V}_{PP}$ , $G = 1$		34		MHz	
Bandwidth for 0.1-dB flatness	$V_{OUT} = 2\text{ V}_{PP}$ , $G = 1$		12		MHz	
Slew rate, rise/fall, 25% to 75%	$V_{OUT} = 2\text{-V step}$		190/320		V/ $\mu\text{s}$	
Rise/fall time, 10% to 90%			5.2/6.1		ns	
Settling time to 1%, rise/fall			25/20		ns	
Settling time to 0.1%, rise/fall			60/60		ns	
Settling time to 0.01%, rise/fall			150/110		ns	
Overshoot/undershoot, rise/fall				1/1%		
2nd-order harmonic distortion	$f = 1\text{ kHz}$ , $V_{OUT} = 1\text{ V}_{RMS}$		-122		dBc	
	$f = 10\text{ kHz}$		-127			
	$f = 1\text{ MHz}$		-59			
3rd-order harmonic distortion	$f = 1\text{ kHz}$ , $V_{OUT} = 1\text{ V}_{RMS}$		-130		dBc	
	$f = 10\text{ kHz}$		-135			
	$f = 1\text{ MHz}$		-70			
2nd-order intermodulation distortion	$f = 1\text{ MHz}$ , 200-kHz tone spacing, $V_{OUT}$ envelope = $2\text{ V}_{PP}$		-83		dBc	
3rd-order intermodulation distortion			-81			
Input voltage noise	$f = 1\text{ kHz}$		10		nV/ $\sqrt{\text{Hz}}$	
Voltage noise 1/f corner frequency			45		Hz	
Input current noise	$f = 100\text{ kHz}$		0.25		pA/ $\sqrt{\text{Hz}}$	
Current noise 1/f corner frequency			6.5		kHz	
Overdrive recovery time	Overdrive = 0.5 V		65		ns	
Output balance error	$V_{OUT} = 100\text{ mV}$ , $f = 1\text{ MHz}$		-65		dB	
Closed-loop output impedance	$f = 1\text{ MHz}$ (differential)		2.5		$\Omega$	
Channel-to-channel crosstalk	$f = 10\text{ kHz}$ , measured differentially		-133		dB	

(1) Node set to midsupply externally; 0.1  $\mu\text{F}$

(2) Test levels (all values set by characterization and simulation): (A) 100% tested at  $+25^\circ\text{C}$ ; over temperature limits by characterization and simulation. (B) Not tested in production; limits set by characterization and simulation. (C) Typical value only for information.

**Electrical Characteristics:  $V_S = 2.7\text{ V}$  (continued)**

Test conditions at  $T_A = 25^\circ\text{C}$ ,  $V_{S+} = 2.7\text{ V}$ ,  $V_{S-} = 0\text{ V}$ ,  $V_{OCM} = +V_S/2^{(1)}$ ,  $V_{OUT} = 2\text{ V}_{PP}$ ,  $R_F = 2\text{ k}\Omega$ ,  $R_L = 2\text{ k}\Omega$  differential,  $G = 1\text{ V/V}$ , single-ended input, differential output, and input and output referenced to mid-supply, unless otherwise noted.

PARAMETER	TEST CONDITIONS	MIN	TYP	MAX	UNIT	TEST LEVEL <sup>(2)</sup>
<b>DC PERFORMANCE</b>						
Open-loop voltage gain ( $A_{OL}$ )		100	113		dB	A
Input-referred offset voltage	$T_A = 25^\circ\text{C}$		$\pm 80$	$\pm 400$	$\mu\text{V}$	A
	$T_A = 0^\circ\text{C}$ to $70^\circ\text{C}$			$\pm 715$		B
	$T_A = -40^\circ\text{C}$ to $85^\circ\text{C}$			$\pm 855$		
	$T_A = -40^\circ\text{C}$ to $125^\circ\text{C}$			$\pm 1300$		
Input offset voltage drift <sup>(3)</sup>	$T_A = 0^\circ\text{C}$ to $70^\circ\text{C}$		$\pm 2$	$\pm 7$	$\mu\text{V}/^\circ\text{C}$	B
	$T_A = -40^\circ\text{C}$ to $85^\circ\text{C}$		$\pm 2$	$\pm 7$		
	$T_A = -40^\circ\text{C}$ to $125^\circ\text{C}$		$\pm 3$	$\pm 9$		
Input bias current	$T_A = 25^\circ\text{C}$		200	250	nA	A
	$T_A = 0^\circ\text{C}$ to $70^\circ\text{C}$			275		B
	$T_A = -40^\circ\text{C}$ to $85^\circ\text{C}$			286		
	$T_A = -40^\circ\text{C}$ to $125^\circ\text{C}$			305		
Input bias current drift <sup>(3)</sup>	$T_A = 0^\circ\text{C}$ to $70^\circ\text{C}$		0.45	0.55	nA/ $^\circ\text{C}$	B
	$T_A = -40^\circ\text{C}$ to $85^\circ\text{C}$		0.45	0.55		
	$T_A = -40^\circ\text{C}$ to $125^\circ\text{C}$		0.45	0.55		
Input offset current	$T_A = 25^\circ\text{C}$		$\pm 5$	$\pm 50$	nA	A
	$T_A = 0^\circ\text{C}$ to $70^\circ\text{C}$			$\pm 55$		B
	$T_A = -40^\circ\text{C}$ to $85^\circ\text{C}$			$\pm 57$		
	$T_A = -40^\circ\text{C}$ to $125^\circ\text{C}$			$\pm 60$		
Input offset current drift <sup>(3)</sup>	$T_A = 0^\circ\text{C}$ to $70^\circ\text{C}$		$\pm 0.03$	$\pm 0.1$	nA/ $^\circ\text{C}$	B
	$T_A = -40^\circ\text{C}$ to $85^\circ\text{C}$		$\pm 0.03$	$\pm 0.1$		
	$T_A = -40^\circ\text{C}$ to $125^\circ\text{C}$		$\pm 0.03$	$\pm 0.1$		
<b>INPUT</b>						
Common-mode input low	$T_A = 25^\circ\text{C}$ , CMRR > 87 dB		$V_{S-} - 0.2$	$V_{S-}$	V	A
	$T_A = -40^\circ\text{C}$ to $125^\circ\text{C}$ , CMRR > 87 dB		$V_{S-} - 0.2$	$V_{S-}$		B
Common-mode input high	$T_A = 25^\circ\text{C}$ , CMRR > 87 dB	$V_{S+} - 1.2$	$V_{S+} - 1.1$		V	A
	$T_A = -40^\circ\text{C}$ to $125^\circ\text{C}$ , CMRR > 87 dB	$V_{S+} - 1.2$	$V_{S+} - 1.1$			B
Common-mode rejection ratio		90	116		dB	A
Input impedance common-mode			200    1.2		k $\Omega$    pF	C
Input impedance differential mode			200    1			C
<b>OUTPUT</b>						
Single-ended output voltage: low	$T_A = 25^\circ\text{C}$		$V_{S+} + 0.06$	$V_{S-} + 0.2$	V	A
	$T_A = -40^\circ\text{C}$ to $125^\circ\text{C}$		$V_{S+} + 0.06$	$V_{S-} + 0.2$		B
Single-ended output voltage: high	$T_A = 25^\circ\text{C}$	$V_{S+} - 0.2$	$V_{S+} - 0.11$		V	A
	$T_A = -40^\circ\text{C}$ to $125^\circ\text{C}$	$V_{S+} - 0.2$	$V_{S+} - 0.11$			B
Output saturation voltage: high/low			110/60		mV	C
Linear output current drive	$T_A = 25^\circ\text{C}$	$\pm 15$	$\pm 22$		mA	A
	$T_A = -40^\circ\text{C}$ to $125^\circ\text{C}$	$\pm 15$				B

(3) Input offset voltage drift, input bias current drift, and input offset current drift are average values calculated by taking data at the end points, computing the difference, and dividing by the temperature range.

**Electrical Characteristics:  $V_S = 2.7\text{ V}$  (continued)**

Test conditions at  $T_A = 25^\circ\text{C}$ ,  $V_{S+} = 2.7\text{ V}$ ,  $V_{S-} = 0\text{ V}$ ,  $V_{OCM} = +V_S/2^{(1)}$ ,  $V_{OUT} = 2\text{ V}_{PP}$ ,  $R_F = 2\text{ k}\Omega$ ,  $R_L = 2\text{ k}\Omega$  differential,  $G = 1\text{ V/V}$ , single-ended input, differential output, and input and output referenced to mid-supply, unless otherwise noted.

PARAMETER	TEST CONDITIONS	MIN	TYP	MAX	UNIT	TEST LEVEL <sup>(2)</sup>
<b>POWER SUPPLY</b>						
Specified operating voltage		2.5		5.5	V	B
Quiescent operating current/ch	$T_A = 25^\circ\text{C}$ , $\overline{PD} = V_{S+}$		230	330	$\mu\text{A}$	A
	$T_A = -40^\circ\text{C}$ to $125^\circ\text{C}$ , $\overline{PD} = V_{S+}$		270	370		B
Power-supply rejection (PSRR)		87	108		dB	A
<b>POWER DOWN</b>						
Enable voltage threshold	Specified on above 2.1 V			2.1	V	A
Disable voltage threshold	Specified off below 0.7 V	0.7			V	A
Disable pin bias current	$\overline{PD} = V_{S-} + 0.5\text{ V}$		50	500	nA	A
Power-down quiescent current	$\overline{PD} = V_{S-} + 0.5\text{ V}$		0.5	2	$\mu\text{A}$	A
Turn-on time delay	Time from $\overline{PD} = \text{high}$ to $V_{OUT} = 90\%$ of final value, $R_L = 200\ \Omega$		650		ns	C
Turn-off time delay	Time from $\overline{PD} = \text{low}$ to $V_{OUT} = 10\%$ of original value, $R_L = 200\ \Omega$		20		ns	C
<b>OUTPUT COMMON-MODE VOLTAGE CONTROL (<math>V_{OCM}</math>)</b>						
Small-signal bandwidth	$V_{OCM}$ input = $100\text{ mV}_{PP}$		23		MHz	C
Slew rate	$V_{OCM}$ input = $1\text{ V}_{STEP}$		14		V/ $\mu\text{s}$	C
Gain		0.99	0.996	1.01	V/V	A
Common-mode offset voltage	Offset = output common-mode voltage – $V_{OCM}$ input voltage		$\pm 1$	$\pm 5$	mV	A
$V_{OCM}$ input bias current	$V_{OCM} = (V_{S+} - V_{S-})/2$		$\pm 20$	$\pm 100$	nA	A
$V_{OCM}$ input voltage range		0.8	0.75 to 1.9	1.75	V	A
$V_{OCM}$ input impedance			100    1.6		k $\Omega$    pF	C
Default voltage offset from $(V_{S+} - V_{S-})/2$	Offset = output common-mode voltage – $(V_{S+} - V_{S-})/2$		$\pm 3$	$\pm 10$	mV	A

## 7.6 Electrical Characteristics: $V_S = 5\text{ V}$

Test conditions at  $T_A = +25^\circ\text{C}$ ,  $V_{S+} = 5\text{ V}$ ,  $V_{S-} = 0\text{ V}$ ,  $V_{OCM} = \text{open}$ ,  $V_{OUT} = 2\text{ V}_{PP}$ ,  $R_F = 2\text{ k}\Omega$ ,  $R_L = 2\text{ k}\Omega$  differential,  $G = 1\text{ V/V}$ , single-ended input, differential output, and input and output referenced to mid-supply, unless otherwise noted.

PARAMETER	TEST CONDITIONS	MIN	TYP	MAX	UNIT	TEST LEVEL <sup>(1)</sup>
<b>AC PERFORMANCE</b>						
Small-signal bandwidth	$V_{OUT} = 100\text{ mV}_{PP}$ , $G = 1$		36		MHz	C
	$V_{OUT} = 100\text{ mV}_{PP}$ , $G = 2$		17			
	$V_{OUT} = 100\text{ mV}_{PP}$ , $G = 5$		6			
	$V_{OUT} = 100\text{ mV}_{PP}$ , $G = 10$		2.7			
Gain-bandwidth product	$V_{OUT} = 100\text{ mV}_{PP}$ , $G = 10$		27		MHz	
Large-signal bandwidth	$V_{OUT} = 2\text{ V}_{PP}$ , $G = 1$		36		MHz	
Bandwidth for 0.1-dB flatness	$V_{OUT} = 2\text{ V}_{PP}$ , $G = 1$		15		MHz	
Slew rate, rise/fall, 25% to 75%	$V_{OUT} = 2\text{ V}_{Step}$		220/390		V/ $\mu\text{s}$	
Rise/fall time, 10% to 90%			4.6/5.6		ns	
Settling time to 1%, rise/fall			25/20		ns	
Settling time to 0.1%, rise/fall			60/60		ns	
Settling time to 0.01%, rise/fall			150/110		ns	
Overshoot/undershoot, rise/fall				1/1%		
2nd-order harmonic distortion	$f = 1\text{ kHz}$ , $V_{OUT} = 1\text{ V}_{RMS}$		-122		dBc	C
	$f = 10\text{ kHz}$		-128			
	$f = 1\text{ MHz}$		-60			
3rd-order harmonic distortion	$f = 1\text{ kHz}$ , $V_{OUT} = 1\text{ V}_{RMS}$		-130		dBc	C
	$f = 10\text{ kHz}$		-137			
	$f = 1\text{ MHz}$		-71			
2nd-order intermodulation distortion	$f = 1\text{ MHz}$ , 200-kHz tone spacing,		-85		dBc	
3rd-order intermodulation distortion	$V_{OUT}$ envelope = $2\text{ V}_{PP}$		-83		dBc	
Input voltage noise	$f = 1\text{ kHz}$		10		nV/ $\sqrt{\text{Hz}}$	
Voltage noise 1/f corner frequency			45		Hz	
Input current noise	$f = 100\text{ kHz}$		0.25		pA/ $\sqrt{\text{Hz}}$	
Current noise 1/f corner frequency			6.5		kHz	
Overdrive recovery time	Overdrive = $0.5\text{ V}$		65		ns	
Output balance error	$V_{OUT} = 100\text{ mV}$ , $f = 1\text{ MHz}$		-67		dB	
Closed-loop output impedance	$f = 1\text{ MHz}$ (differential)		2.5		$\Omega$	
Channel-to-channel crosstalk	$f = 10\text{ kHz}$ , measured differentially		-133		dB	

(1) Test levels (all values set by characterization and simulation): (A) 100% tested at  $+25^\circ\text{C}$ ; over temperature limits by characterization and simulation. (B) Not tested in production; limits set by characterization and simulation. (C) Typical value only for information.

**Electrical Characteristics:  $V_S = 5\text{ V}$  (continued)**

Test conditions at  $T_A = +25^\circ\text{C}$ ,  $V_{S+} = 5\text{ V}$ ,  $V_{S-} = 0\text{ V}$ ,  $V_{OCM} = \text{open}$ ,  $V_{OUT} = 2\text{ V}_{PP}$ ,  $R_F = 2\text{ k}\Omega$ ,  $R_L = 2\text{ k}\Omega$  differential,  $G = 1\text{ V/V}$ , single-ended input, differential output, and input and output referenced to mid-supply, unless otherwise noted.

PARAMETER	TEST CONDITIONS	MIN	TYP	MAX	UNIT	TEST LEVEL <sup>(1)</sup>
<b>DC PERFORMANCE</b>						
Open-loop voltage gain ( $A_{OL}$ )		100	114		dB	A
Input-referred offset voltage	$T_A = 25^\circ\text{C}$		$\pm 80$	$\pm 400$	$\mu\text{V}$	A
	$T_A = 0^\circ\text{C}$ to $70^\circ\text{C}$			$\pm 715$		B
	$T_A = -40^\circ\text{C}$ to $85^\circ\text{C}$			$\pm 855$		
	$T_A = -40^\circ\text{C}$ to $125^\circ\text{C}$			$\pm 1300$		
Input offset voltage drift <sup>(2)</sup>	$T_A = 0^\circ\text{C}$ to $70^\circ\text{C}$		$\pm 2$	$\pm 7$	$\mu\text{V}/^\circ\text{C}$	B
	$T_A = -40^\circ\text{C}$ to $85^\circ\text{C}$		$\pm 2$	$\pm 7$		
	$T_A = -40^\circ\text{C}$ to $125^\circ\text{C}$		$\pm 3$	$\pm 9$		
Input bias current	$T_A = 25^\circ\text{C}$		200	250	nA	A
	$T_A = 0^\circ\text{C}$ to $70^\circ\text{C}$			279		B
	$T_A = -40^\circ\text{C}$ to $85^\circ\text{C}$			292		
	$T_A = -40^\circ\text{C}$ to $125^\circ\text{C}$			315		
Input bias current drift <sup>(2)</sup>	$T_A = 0^\circ\text{C}$ to $70^\circ\text{C}$		0.5	0.65	nA/ $^\circ\text{C}$	B
	$T_A = -40^\circ\text{C}$ to $85^\circ\text{C}$		0.5	0.65		
	$T_A = -40^\circ\text{C}$ to $125^\circ\text{C}$		0.5	0.65		
Input offset current	$T_A = 25^\circ\text{C}$		$\pm 5$	$\pm 50$	nA	A
	$T_A = 0^\circ\text{C}$ to $70^\circ\text{C}$			$\pm 55$		B
	$T_A = -40^\circ\text{C}$ to $85^\circ\text{C}$			$\pm 57$		
	$T_A = -40^\circ\text{C}$ to $125^\circ\text{C}$			$\pm 60$		
Input offset current drift <sup>(2)</sup>	$T_A = 0^\circ\text{C}$ to $70^\circ\text{C}$		$\pm 0.03$	$\pm 0.1$	nA/ $^\circ\text{C}$	B
	$T_A = -40^\circ\text{C}$ to $85^\circ\text{C}$		$\pm 0.03$	$\pm 0.1$		
	$T_A = -40^\circ\text{C}$ to $125^\circ\text{C}$		$\pm 0.03$	$\pm 0.1$		
<b>INPUT</b>						
Common-mode input: low	$T_A = 25^\circ\text{C}$ , CMRR > 87 dB		$V_{S-} - 0.2$	$V_{S-}$	V	A
	$T_A = -40^\circ\text{C}$ to $125^\circ\text{C}$ , CMRR > 87 dB		$V_{S-} - 0.2$	$V_{S-}$		B
Common-mode input: high	$T_A = 25^\circ\text{C}$ , CMRR > 87 dB	$V_{S+} - 1.2$	$V_{S+} - 1.1$		V	A
	$T_A = -40^\circ\text{C}$ to $125^\circ\text{C}$ , CMRR > 87 dB	$V_{S+} - 1.2$	$V_{S+} - 1.1$			B
Common-mode rejection ratio		90	116		dB	A
Input impedance common-mode			200    1.2		k $\Omega$    pF	C
Input impedance differential mode			200    1			C
<b>OUTPUT</b>						
Linear output voltage: low	$T_A = 25^\circ\text{C}$		$V_{S-} + 0.1$	$V_{S-} + 0.2$	V	A
	$T_A = -40^\circ\text{C}$ to $125^\circ\text{C}$		$V_{S-} + 0.1$	$V_{S-} + 0.2$	V	B
Linear output voltage: high	$T_A = 25^\circ\text{C}$	$V_{S+} - 0.25$	$V_{S+} - 0.12$		V	A
	$T_A = -40^\circ\text{C}$ to $125^\circ\text{C}$	$V_{S+} - 0.25$	$V_{S+} - 0.12$		V	B
Output saturation voltage: high/low			120/100		mV	C
Linear output current drive	$T_A = 25^\circ\text{C}$	$\pm 15$	$\pm 25$		mA	A
	$T_A = -40^\circ\text{C}$ to $125^\circ\text{C}$	$\pm 15$				B

(2) Input offset voltage drift, input bias current drift, and input offset current drift are average values calculated by taking data at the end points, computing the difference, and dividing by the temperature range.

**Electrical Characteristics:  $V_S = 5\text{ V}$  (continued)**

Test conditions at  $T_A = +25^\circ\text{C}$ ,  $V_{S+} = 5\text{ V}$ ,  $V_{S-} = 0\text{ V}$ ,  $V_{OCM} = \text{open}$ ,  $V_{OUT} = 2\text{ V}_{PP}$ ,  $R_F = 2\text{ k}\Omega$ ,  $R_L = 2\text{ k}\Omega$  differential,  $G = 1\text{ V/V}$ , single-ended input, differential output, and input and output referenced to mid-supply, unless otherwise noted.

PARAMETER	TEST CONDITIONS	MIN	TYP	MAX	UNIT	TEST LEVEL (1)
<b>POWER SUPPLY</b>						
Specified operating voltage		2.5		5.5	V	B
Quiescent operating current/ch	$T_A = 25^\circ\text{C}$ , $\overline{PD} = V_{S+}$		250	350	$\mu\text{A}$	A
	$T_A = -40^\circ\text{C}$ to $125^\circ\text{C}$ , $\overline{PD} = V_{S+}$		290	390		B
Power-supply rejection (PSRR)		87	108		dB	A
<b>POWER DOWN</b>						
Enable voltage threshold	Specified on above 2.1 V			2.1	V	A
Disable voltage threshold	Specified off below 0.7 V	0.7			V	A
Disable pin bias current	$\overline{PD} = V_{S-} + 0.5\text{ V}$		50	500	nA	A
Power-down quiescent current	$\overline{PD} = V_{S-} + 0.5\text{ V}$		0.5	2	$\mu\text{A}$	A
Turn-on time delay	Time from $\overline{PD} = \text{high}$ to $V_{OUT} = 90\%$ of final value, $R_L = 200\ \Omega$		600		ns	C
Turn-off time delay	Time from $\overline{PD} = \text{low}$ to $V_{OUT} = 10\%$ of original value, $R_L = 200\ \Omega$		15		ns	C
<b>OUTPUT COMMON-MODE VOLTAGE CONTROL (<math>V_{OCM}</math>)</b>						
Small-signal bandwidth	$V_{OCM}$ input = $100\text{ mV}_{PP}$		24		MHz	C
Slew rate	$V_{OCM}$ input = $1\text{ V}_{STEP}$		15		V/ $\mu\text{s}$	C
Gain		0.99	0.996	1.01	V/V	A
Common-mode offset voltage	Offset = output common-mode voltage – $V_{OCM}$ input voltage		$\pm 1$	$\pm 5$	mV	A
$V_{OCM}$ input bias current	$V_{OCM} = (V_{S+} - V_{S-})/2$		$\pm 20$	$\pm 120$	nA	A
$V_{OCM}$ input voltage range		0.95	0.75 to 4.15	4.0	V	A
$V_{OCM}$ input impedance			65    0.86		k $\Omega$    pF	C
Default voltage offset from $(V_{S+} - V_{S-})/2$	Offset = output common-mode voltage – $(V_{S+} - V_{S-})/2$		$\pm 3$	$\pm 10$	mV	A

## 7.7 Typical Characteristics

**Table 3. Table of Graphs**

DESCRIPTION	$V_S = 2.7\text{ V}$	$V_S = 5\text{ V}$
Small-signal frequency response	<a href="#">Figure 1</a>	<a href="#">Figure 35</a>
Large-signal frequency response	<a href="#">Figure 2</a>	<a href="#">Figure 36</a>
Large- and small- signal pulse response	<a href="#">Figure 3</a>	<a href="#">Figure 37</a>
Single-ended slew rate vs $V_{OUT}$ step	<a href="#">Figure 4</a>	<a href="#">Figure 38</a>
Differential slew rate vs $V_{OUT}$ step	<a href="#">Figure 5</a>	<a href="#">Figure 39</a>
Overdrive recovery	<a href="#">Figure 6</a>	<a href="#">Figure 40</a>
10-kHz FFT on audio analyzer	<a href="#">Figure 7</a>	<a href="#">Figure 41</a>
Harmonic distortion vs Frequency	<a href="#">Figure 8</a>	<a href="#">Figure 42</a>
Harmonic distortion vs Output voltage at 1 MHz	<a href="#">Figure 9</a>	<a href="#">Figure 43</a>
Harmonic distortion vs Gain at 1 MHz	<a href="#">Figure 10</a>	<a href="#">Figure 44</a>
Harmonic distortion vs Load at 1 MHz	<a href="#">Figure 11</a>	<a href="#">Figure 45</a>
Harmonic distortion vs $V_{OCM}$ at 1 MHz	<a href="#">Figure 12</a>	<a href="#">Figure 46</a>
Two-tone, 2nd and 3rd order intermodulation distortion vs Frequency	<a href="#">Figure 13</a>	<a href="#">Figure 47</a>
Single-ended output voltage swing vs Load resistance	<a href="#">Figure 14</a>	<a href="#">Figure 48</a>
Single-ended output saturation voltage vs Load current	<a href="#">Figure 15</a>	<a href="#">Figure 49</a>
Main amplifier differential output impedance vs Frequency	<a href="#">Figure 16</a>	<a href="#">Figure 50</a>
Frequency response vs $C_{LOAD}$	<a href="#">Figure 17</a>	<a href="#">Figure 51</a>
$R_O$ vs $C_{LOAD}$	<a href="#">Figure 18</a>	<a href="#">Figure 52</a>
Rejection ratio vs Frequency	<a href="#">Figure 19</a>	<a href="#">Figure 53</a>
Crosstalk vs Frequency	<a href="#">Figure 20</a>	<a href="#">Figure 54</a>
Turn-on time	<a href="#">Figure 21</a>	<a href="#">Figure 55</a>
Turn-off time	<a href="#">Figure 22</a>	<a href="#">Figure 56</a>
Input-referred voltage noise and current noise spectral density	<a href="#">Figure 23</a>	<a href="#">Figure 57</a>
Main amplifier differential open-loop gain and phase vs Frequency	<a href="#">Figure 24</a>	<a href="#">Figure 58</a>
Output balance error vs Frequency	<a href="#">Figure 25</a>	<a href="#">Figure 59</a>
$V_{OCM}$ small signal frequency response	<a href="#">Figure 26</a>	<a href="#">Figure 60</a>
$V_{OCM}$ large and small signal pulse response	<a href="#">Figure 27</a>	<a href="#">Figure 61</a>
$V_{OCM}$ input impedance vs frequency	<a href="#">Figure 28</a>	<a href="#">Figure 62</a>
Count vs input offset current	<a href="#">Figure 29</a>	<a href="#">Figure 63</a>
Count vs input offset current temperature drift	<a href="#">Figure 30</a>	<a href="#">Figure 64</a>
Input offset current vs temperature	<a href="#">Figure 31</a>	<a href="#">Figure 65</a>
Count vs input offset voltage	<a href="#">Figure 32</a>	<a href="#">Figure 66</a>
Count vs input offset voltage temperature drift	<a href="#">Figure 33</a>	<a href="#">Figure 67</a>
Input offset voltage vs temperature	<a href="#">Figure 34</a>	<a href="#">Figure 68</a>

7.7.1 Typical Characteristics:  $V_S = 2.7\text{ V}$

$V_{S+} = 2.7\text{ V}$ ,  $V_{S-} = 0\text{ V}$ , CM = open,  $V_{OUT} = 2\text{ Vpp}$ ,  $R_F = 2\text{ k}\Omega$ ,  $R_L = 2\text{ k}\Omega$  Differential,  $G = 1\text{ V/V}$ , Single-Ended Input, Differential Output, Input and Output Referenced to mid-supply unless otherwise noted.

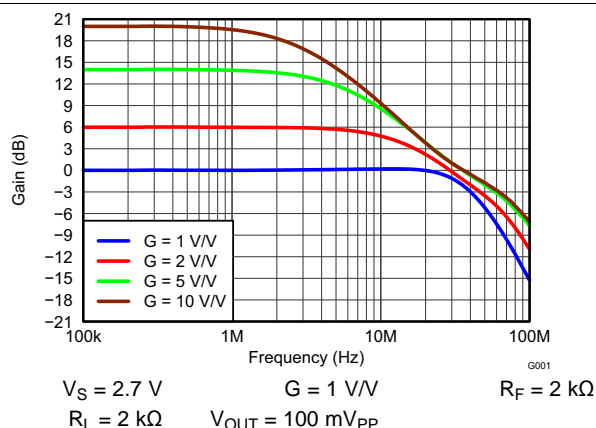

Figure 1. Small-Signal Frequency Response

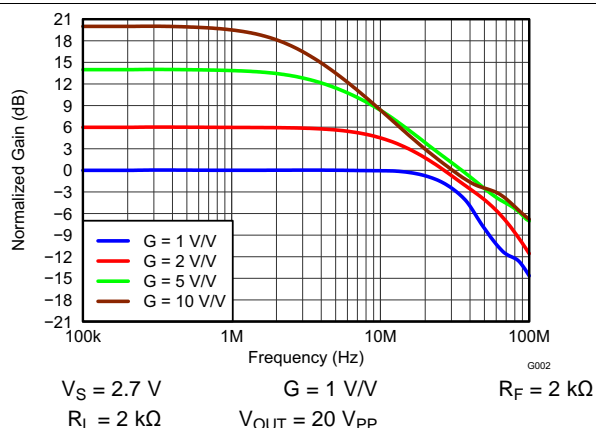

Figure 2. Large-Signal Frequency Response

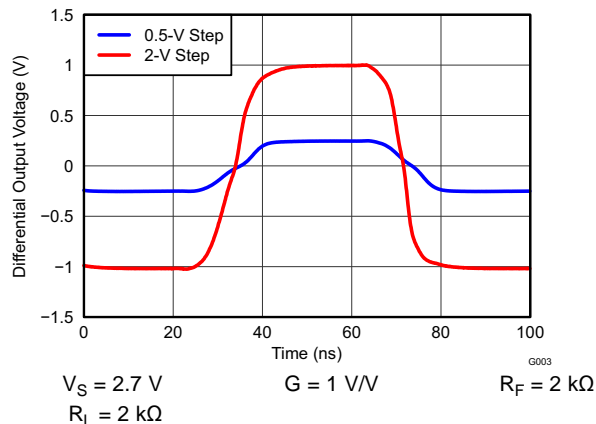

Figure 3. Large- and Small-Signal Pulse Response

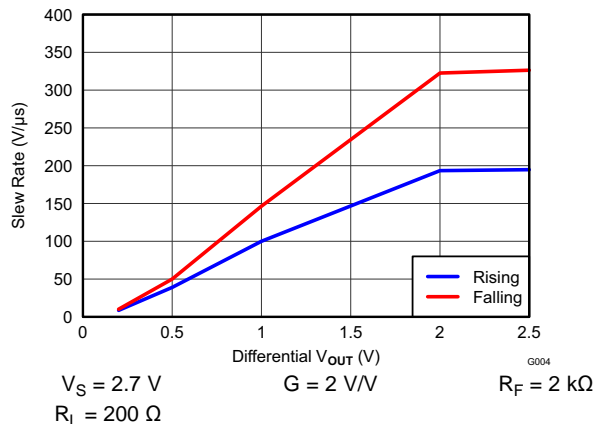

Figure 4. Single-Ended Slew Rate vs  $V_{OUT}$  Step

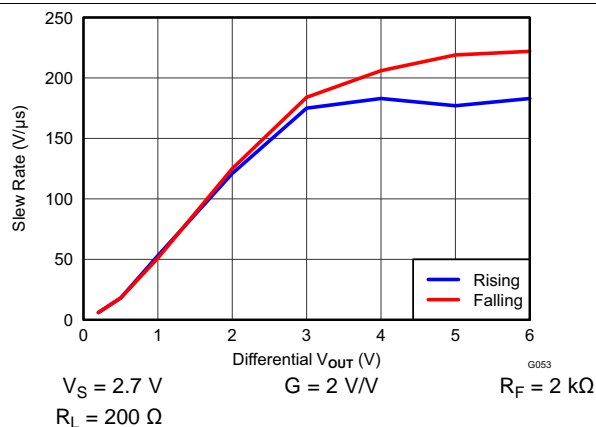

Figure 5. Differential Slew Rate vs  $V_{OUT}$  Step

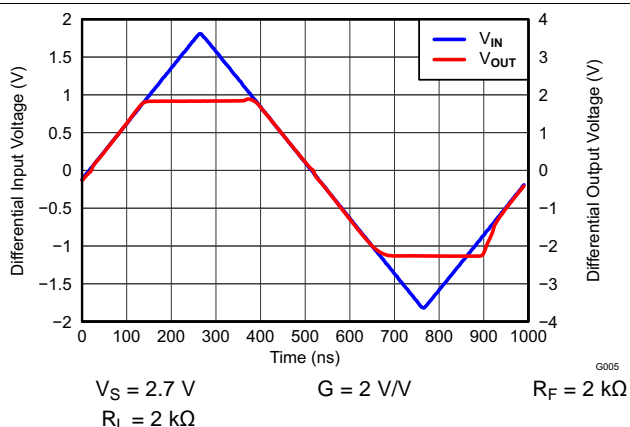
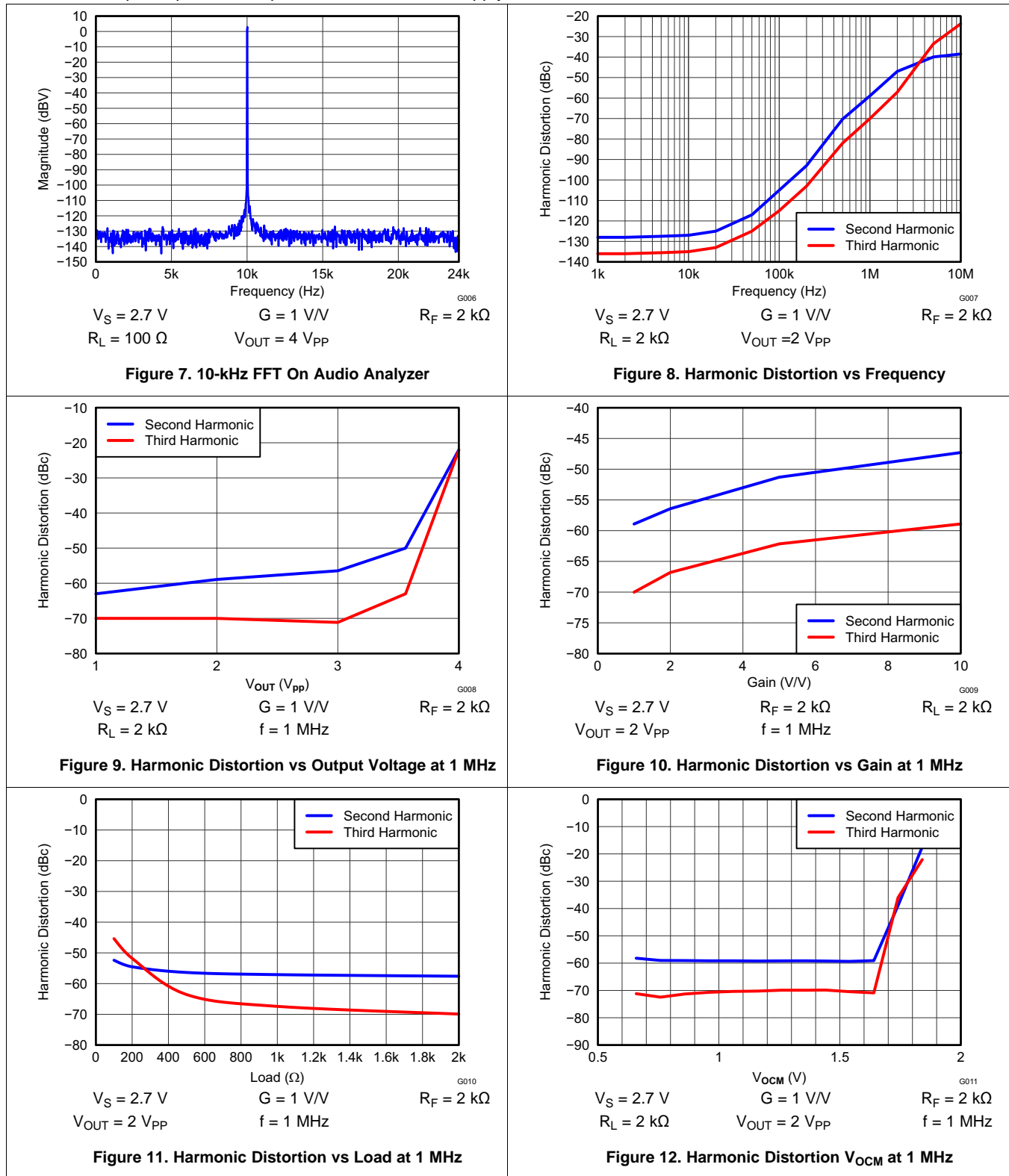

Figure 6. Overdrive Recovery

**Typical Characteristics:  $V_S = 2.7\text{ V}$  (continued)**

$V_{S+} = 2.7\text{ V}$ ,  $V_{S-} = 0\text{ V}$ , CM = open,  $V_{OUT} = 2\text{ V}_{pp}$ ,  $R_F = 2\text{ k}\Omega$ ,  $R_L = 2\text{ k}\Omega$  Differential,  $G = 1\text{ V/V}$ , Single-Ended Input, Differential Output, Input and Output Referenced to mid-supply unless otherwise noted.



Typical Characteristics:  $V_S = 2.7\text{ V}$  (continued)

$V_{S+} = 2.7\text{ V}$ ,  $V_{S-} = 0\text{ V}$ , CM = open,  $V_{OUT} = 2\text{ V}_{PP}$ ,  $R_F = 2\text{ k}\Omega$ ,  $R_L = 2\text{ k}\Omega$  Differential,  $G = 1\text{ V/V}$ , Single-Ended Input, Differential Output, Input and Output Referenced to mid-supply unless otherwise noted.

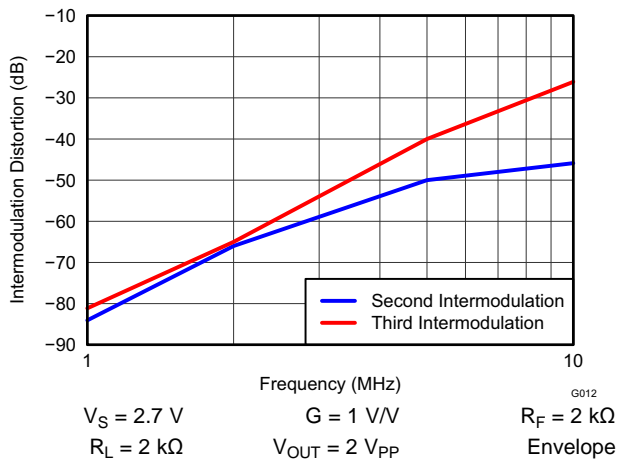

Figure 13. Two-Tone, 2<sup>nd</sup> and 3<sup>rd</sup> Order Intermodulation Distortion vs Frequency

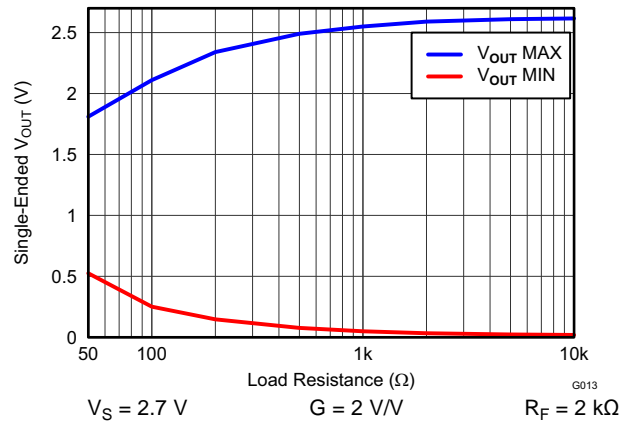

Figure 14. Single-Ended Output Voltage Swing vs Load Resistance

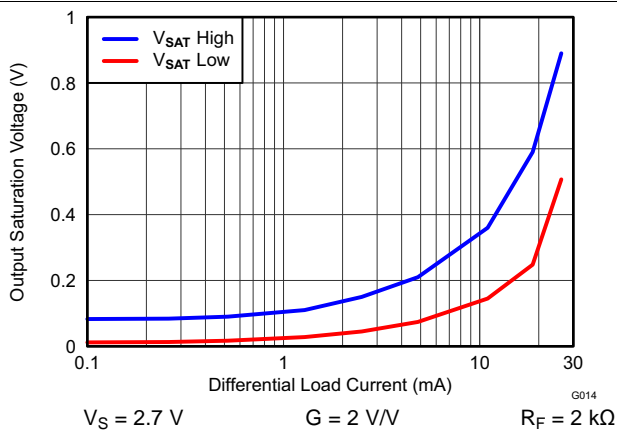

Figure 15. Single-Ended Output Saturation Voltage vs Load Current

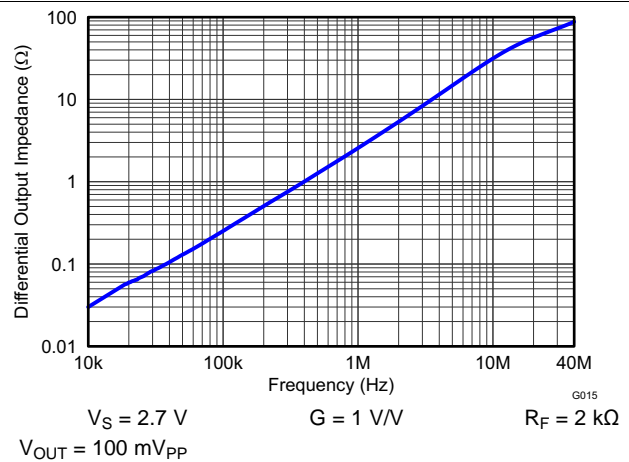

Figure 16. Main Amplifier Differential Output Impedance vs Frequency

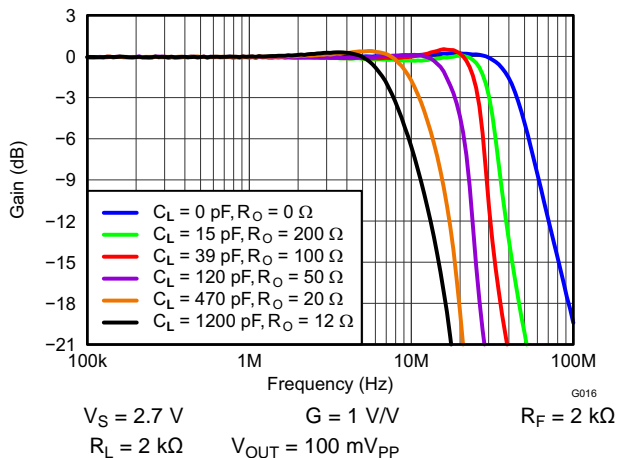

Figure 17. Frequency Response vs  $C_{LOAD}$

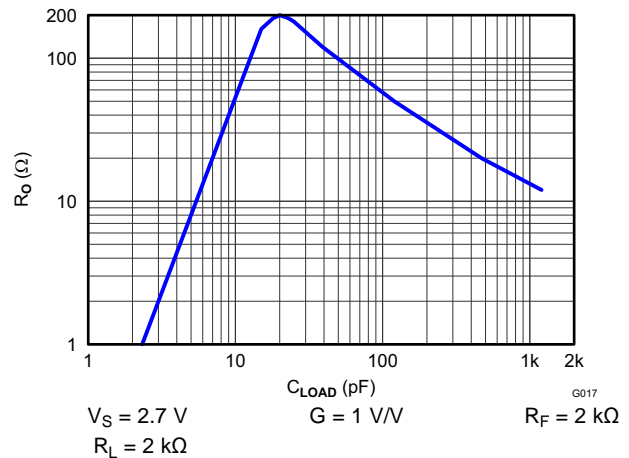
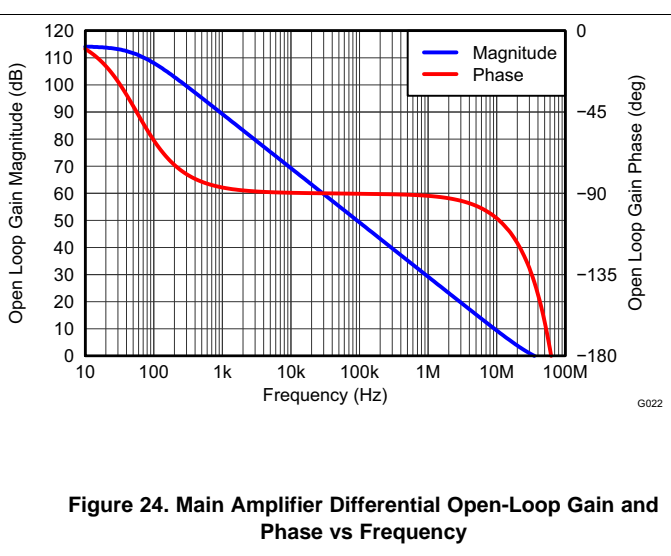
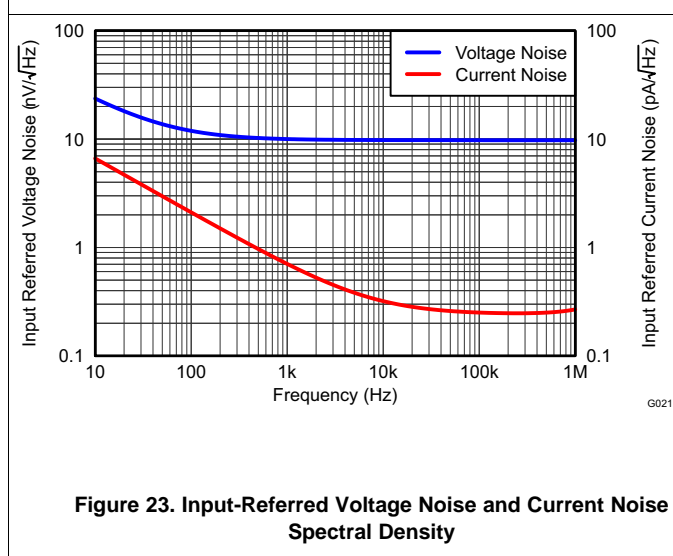
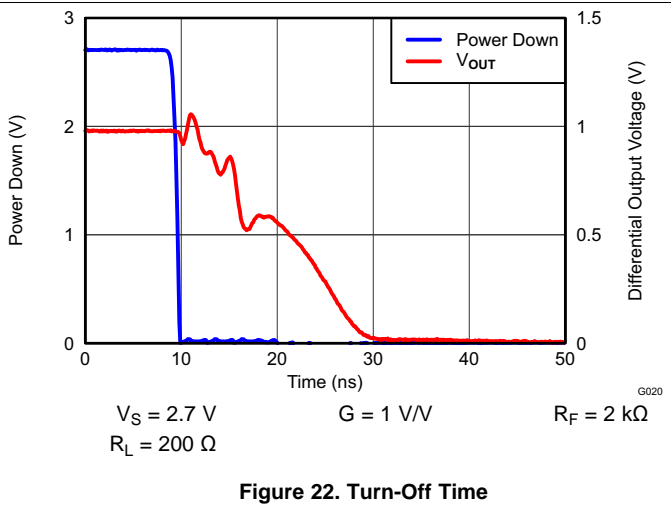
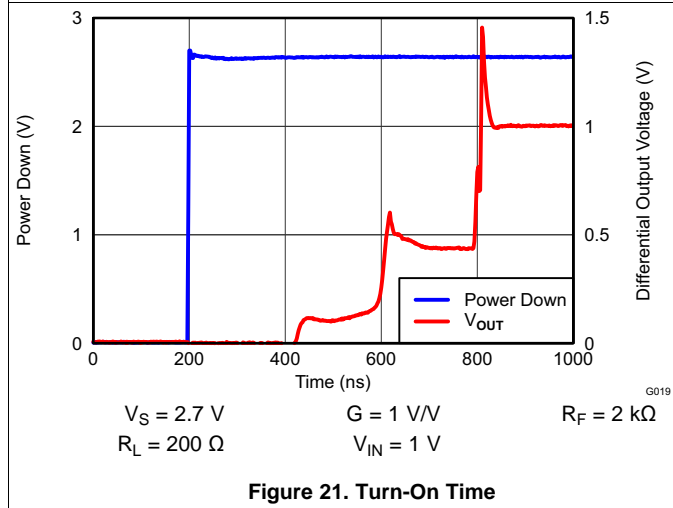
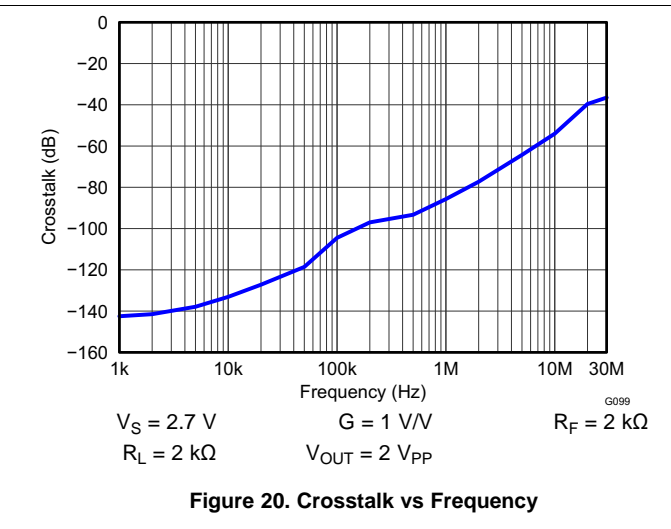
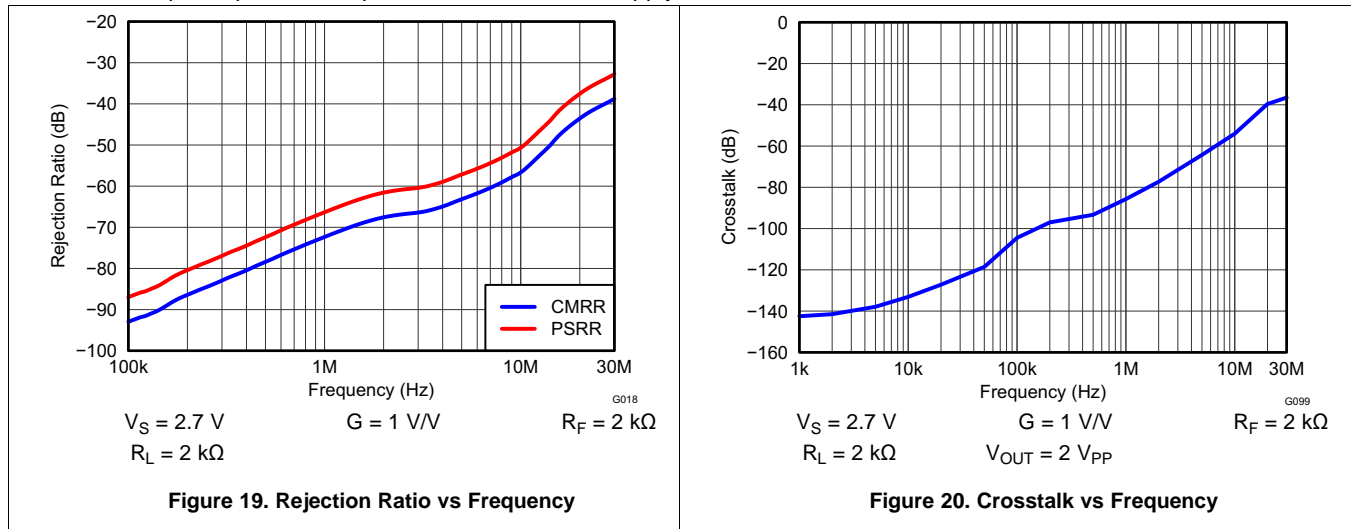

Figure 18.  $R_O$  vs  $C_{LOAD}$

Typical Characteristics:  $V_S = 2.7\text{ V}$  (continued)

$V_{S+} = 2.7\text{ V}$ ,  $V_{S-} = 0\text{ V}$ , CM = open,  $V_{OUT} = 2\text{ Vpp}$ ,  $R_F = 2\text{ k}\Omega$ ,  $R_L = 2\text{ k}\Omega$  Differential,  $G = 1\text{ V/V}$ , Single-Ended Input, Differential Output, Input and Output Referenced to mid-supply unless otherwise noted.



Typical Characteristics:  $V_S = 2.7\text{ V}$  (continued)

$V_{S+} = 2.7\text{ V}$ ,  $V_{S-} = 0\text{ V}$ , CM = open,  $V_{OUT} = 2\text{ Vpp}$ ,  $R_F = 2\text{ k}\Omega$ ,  $R_L = 2\text{ k}\Omega$  Differential,  $G = 1\text{ V/V}$ , Single-Ended Input, Differential Output, Input and Output Referenced to mid-supply unless otherwise noted.

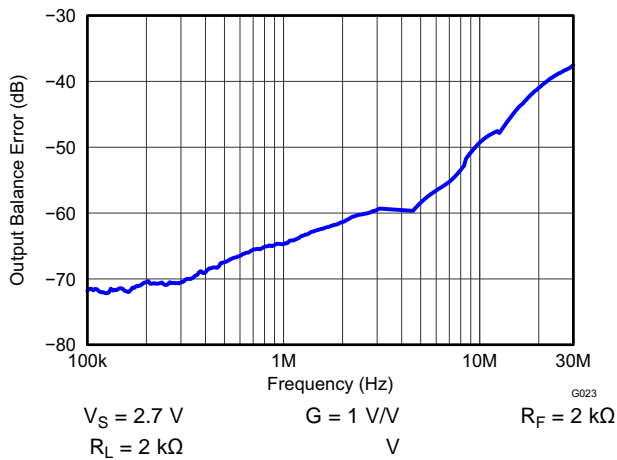

Figure 25. Output Balance Error vs Frequency

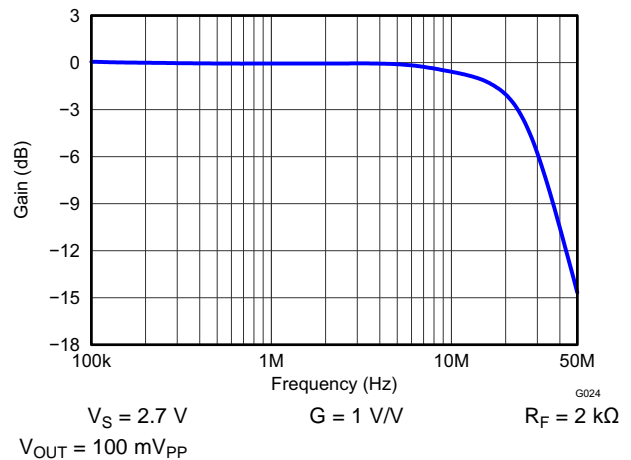

Figure 26.  $V_{OCM}$  Small-Signal Frequency Response

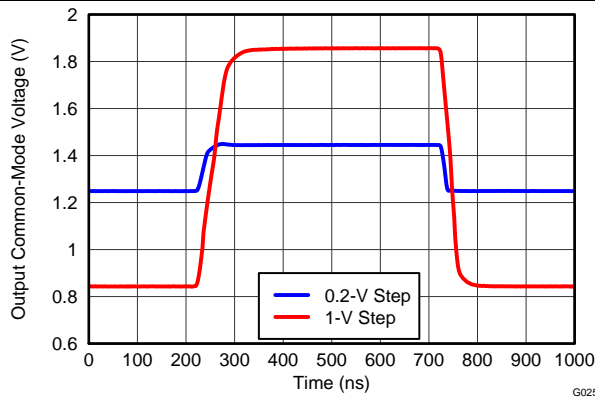

Figure 27.  $V_{OCM}$  Large- and Small Signal Pulse Response

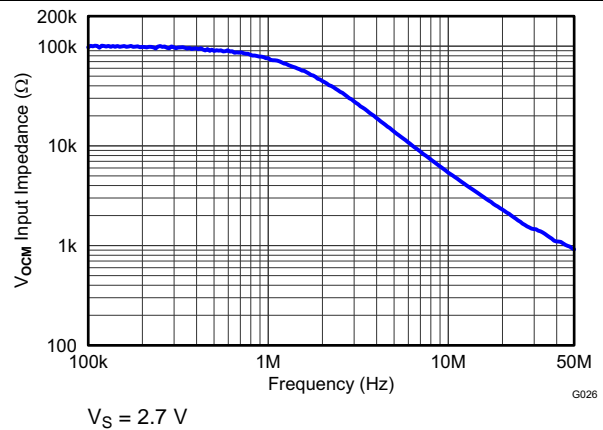

Figure 28.  $V_{OCM}$  Input Impedance vs Frequency

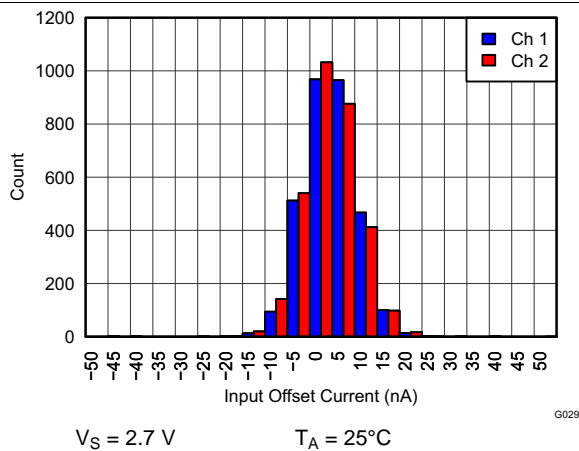

Figure 29. THS4532IPW Input Offset Current Histogram

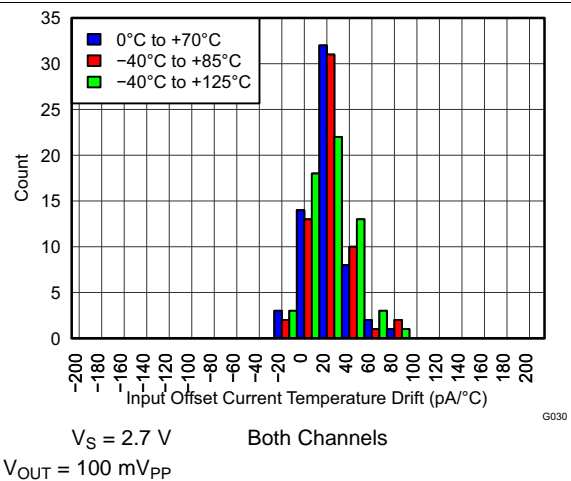

Figure 30. THS4532IPW Input Offset Current Temp Drift Histogram

Typical Characteristics:  $V_S = 2.7\text{ V}$  (continued)

$V_{S+} = 2.7\text{ V}$ ,  $V_{S-} = 0\text{ V}$ , CM = open,  $V_{OUT} = 2\text{ Vpp}$ ,  $R_F = 2\text{ k}\Omega$ ,  $R_L = 2\text{ k}\Omega$  Differential,  $G = 1\text{ V/V}$ , Single-Ended Input, Differential Output, Input and Output Referenced to mid-supply unless otherwise noted.

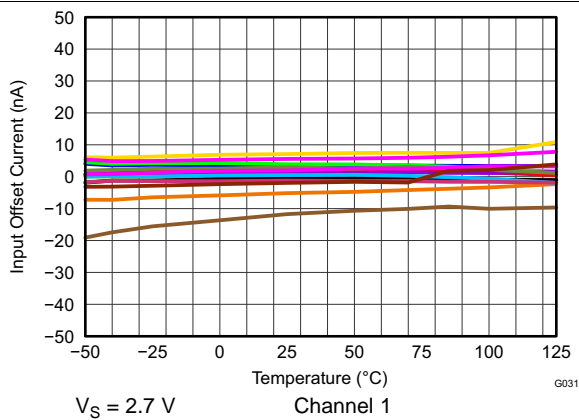

Figure 31. THS4532IPW Input Offset Current vs Temperature

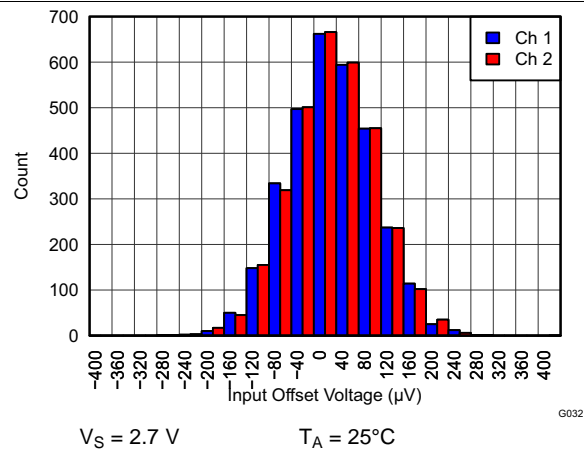

Figure 32. THS4532IPW Input Offset Voltage Histogram

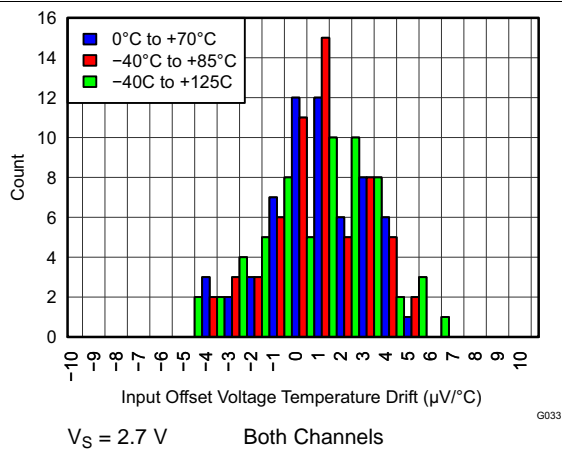

Figure 33. THS4532IPW Input Offset Voltage Temp Drift Histogram

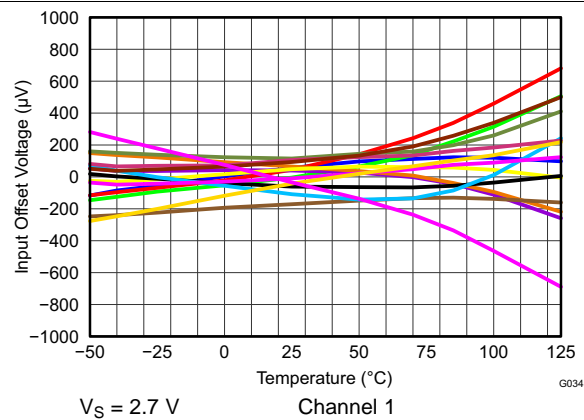

Figure 34. THS4532IPW Input Offset Voltage vs Temperature

7.7.2 Typical Characteristics:  $V_S = 5\text{ V}$

$V_{S+} = 5\text{ V}$ ,  $V_{S-} = 0\text{ V}$ ,  $V_{OCM} = \text{open}$ ,  $V_{OUT} = 2\text{ V}_{pp}$ ,  $R_F = 2\text{ k}\Omega$ ,  $R_L = 2\text{ k}\Omega$  Differential,  $G = 1\text{ V/V}$ , Single-Ended Input, Differential Output, Input and Output Referenced to mid-supply,  $T_A = 25^\circ\text{C}$  unless otherwise noted.

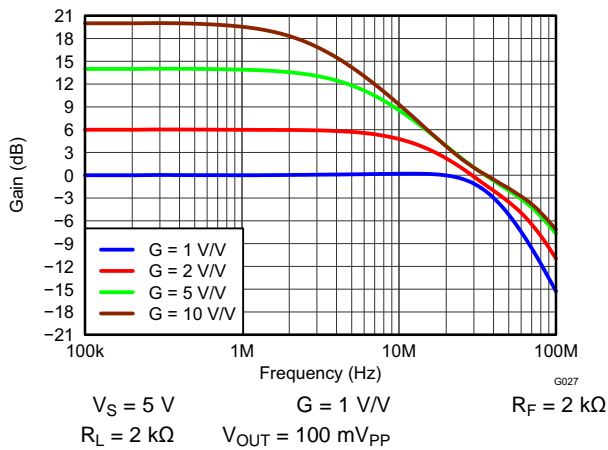

Figure 35. Small-Signal Frequency Response

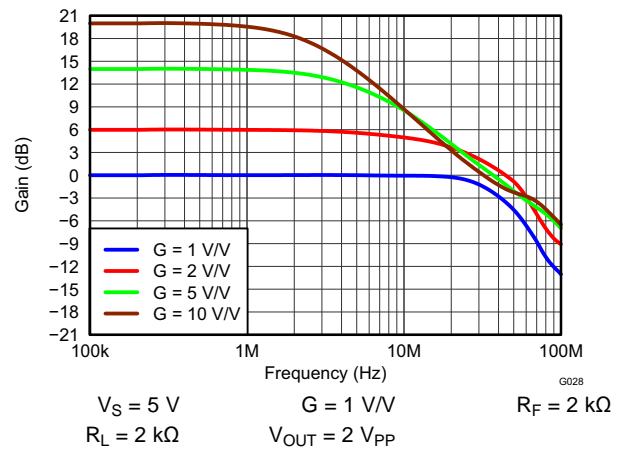

Figure 36. Large-Signal Frequency Response

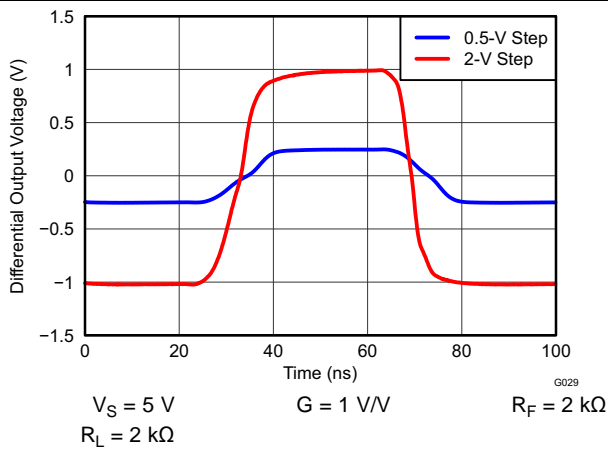

Figure 37. Large- and Small-Signal Pulse Response

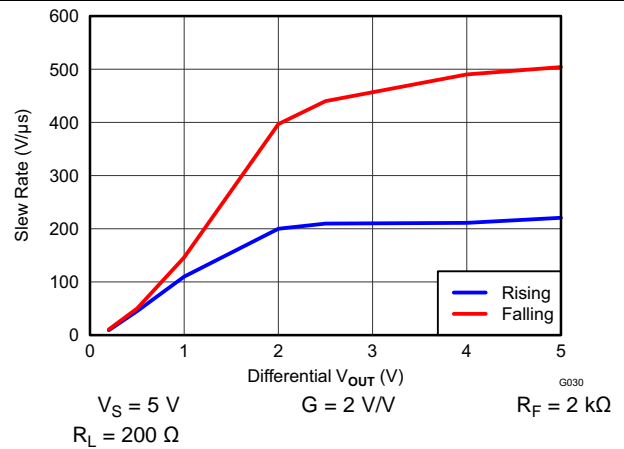

Figure 38. Single-Ended Slew Rate vs  $V_{OUT}$  Step

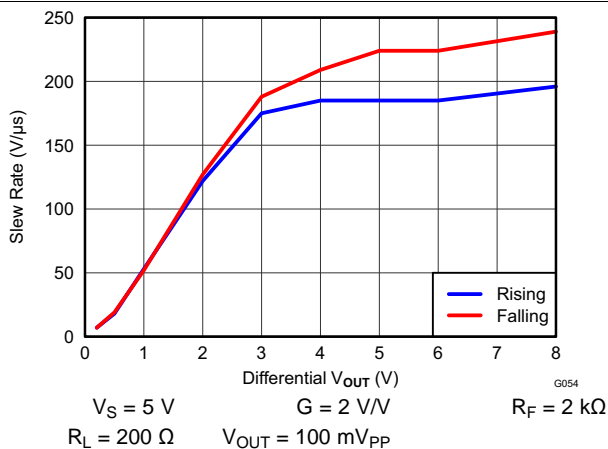

Figure 39. Differential Slew Rate vs  $V_{OUT}$  Step

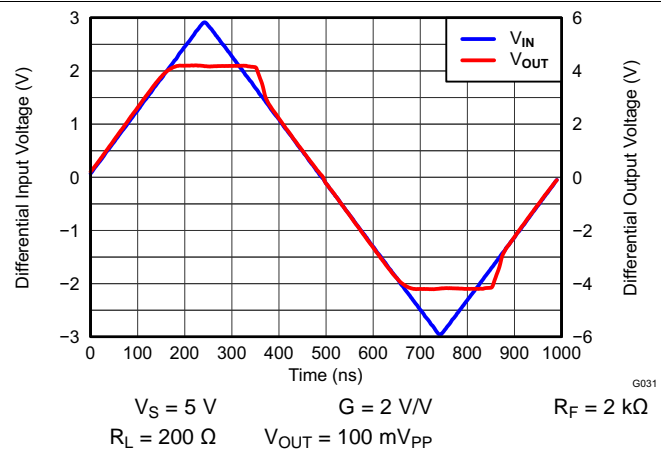
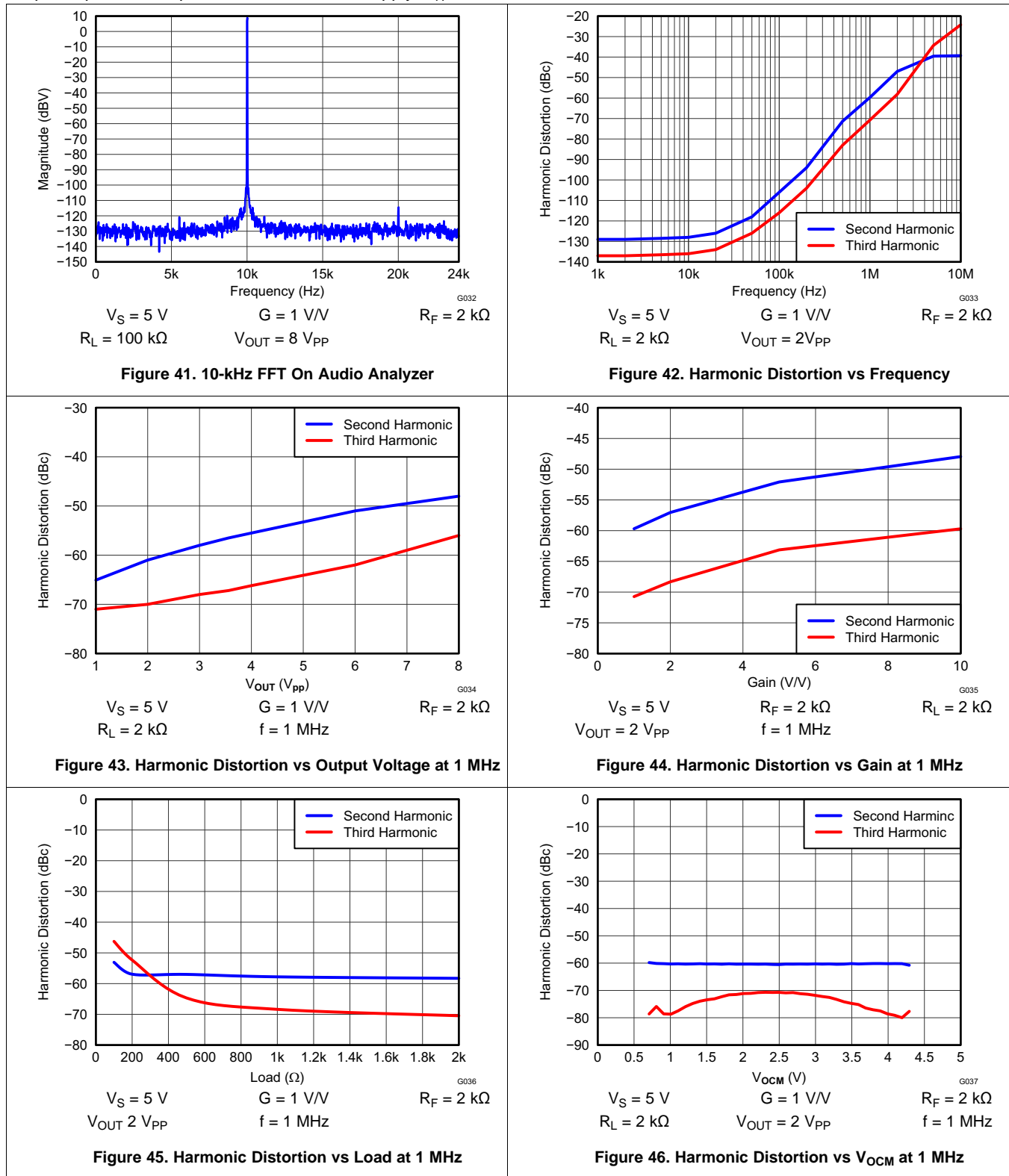

Figure 40. Overdrive Recovery

**Typical Characteristics:  $V_S = 5\text{ V}$  (continued)**

$V_{S+} = 5\text{ V}$ ,  $V_{S-} = 0\text{ V}$ ,  $V_{OCM} = \text{open}$ ,  $V_{OUT} = 2\text{ V}_{pp}$ ,  $R_F = 2\text{ k}\Omega$ ,  $R_L = 2\text{ k}\Omega$  Differential,  $G = 1\text{ V/V}$ , Single-Ended Input, Differential Output, Input and Output Referenced to mid-supply,  $T_A = 25^\circ\text{C}$  unless otherwise noted.



Typical Characteristics:  $V_S = 5\text{ V}$  (continued)

$V_{S+} = 5\text{ V}$ ,  $V_{S-} = 0\text{ V}$ ,  $V_{OCM} = \text{open}$ ,  $V_{OUT} = 2\text{ V}_{PP}$ ,  $R_F = 2\text{ k}\Omega$ ,  $R_L = 2\text{ k}\Omega$  Differential,  $G = 1\text{ V/V}$ , Single-Ended Input, Differential Output, Input and Output Referenced to mid-supply,  $T_A = 25^\circ\text{C}$  unless otherwise noted.

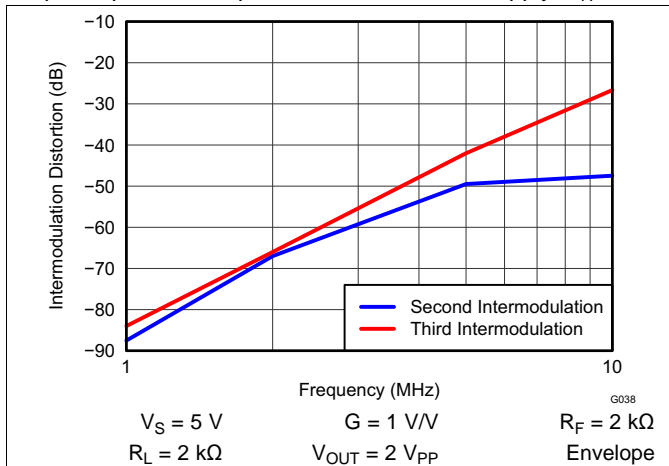

Figure 47. Two-Tone, 2<sup>nd</sup> and 3<sup>rd</sup> Order Intermodulation Distortion vs Frequency

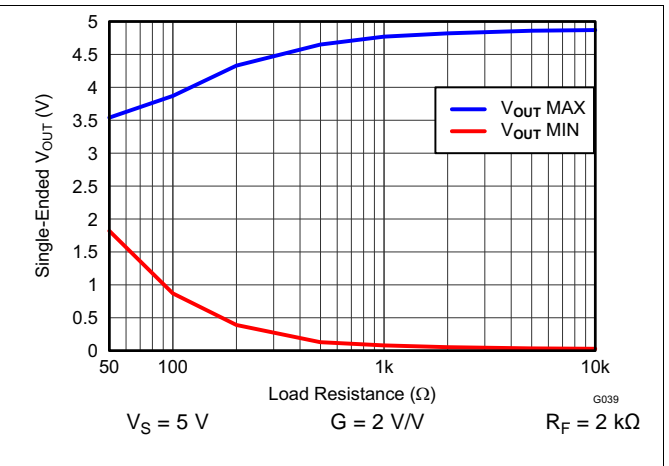

Figure 48. Single-Ended Output Voltage Swing vs Load Resistance

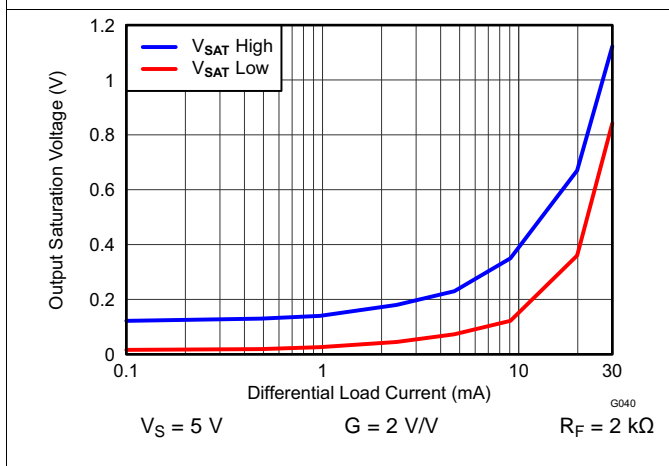

Figure 49. Single-Ended Output Saturation Voltage vs Load Current

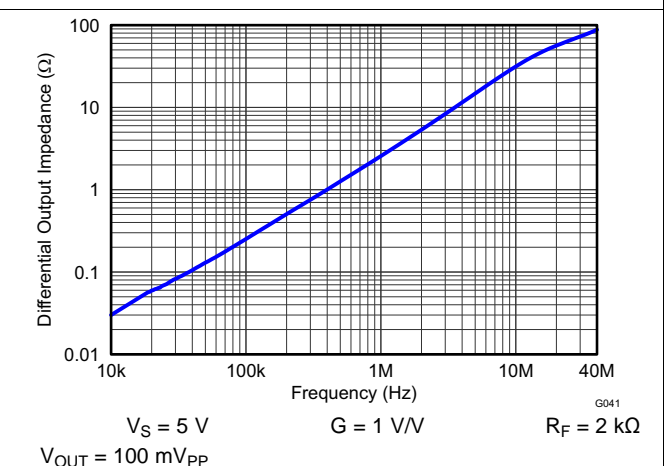

Figure 50. Main Amplifier Differential Output Impedance vs Frequency

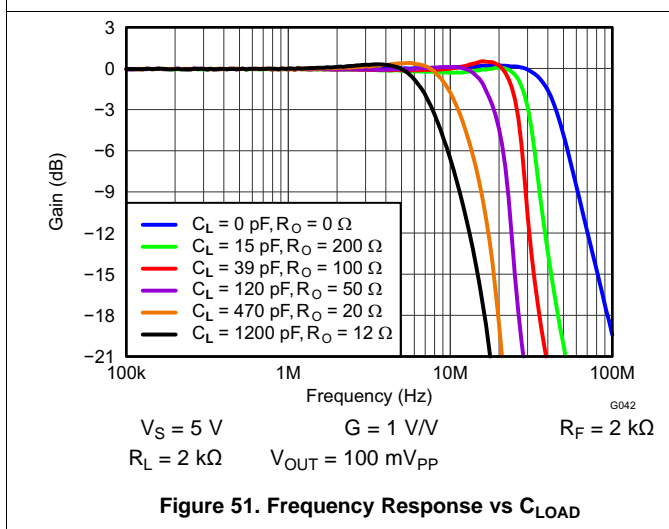

Figure 51. Frequency Response vs  $C_{LOAD}$

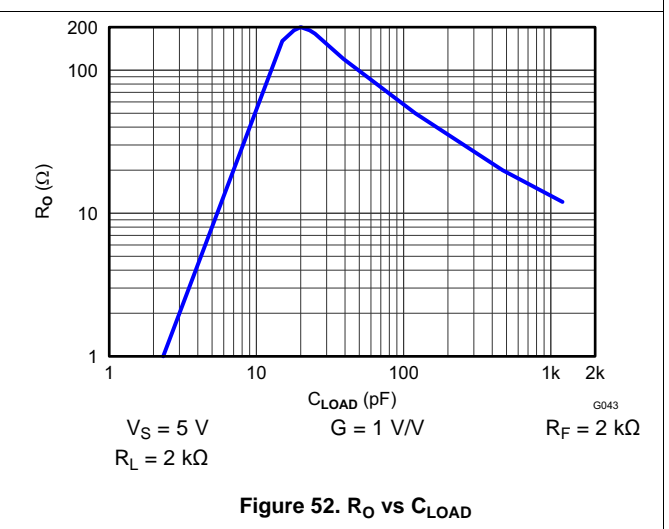
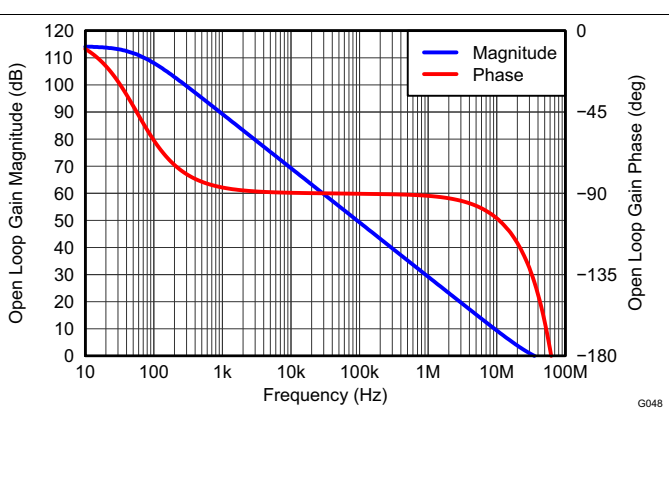
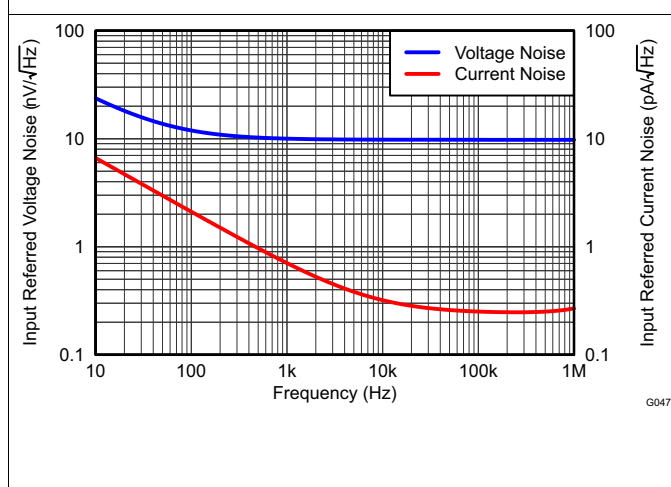
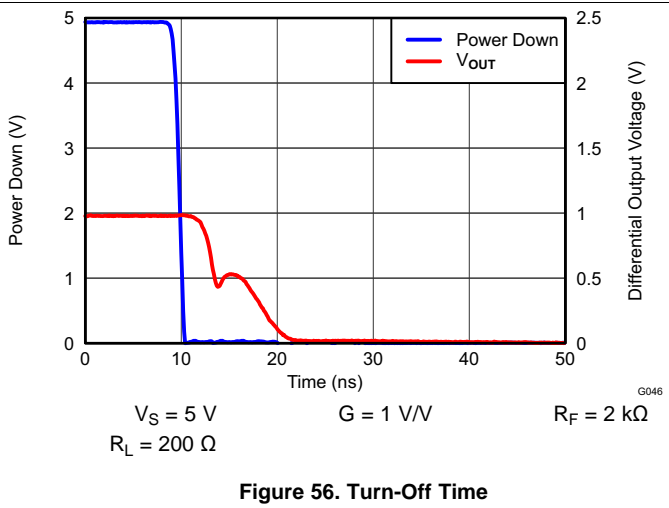
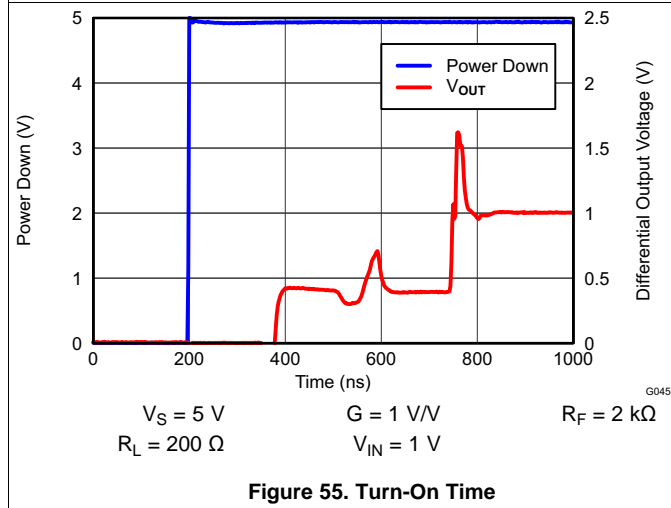
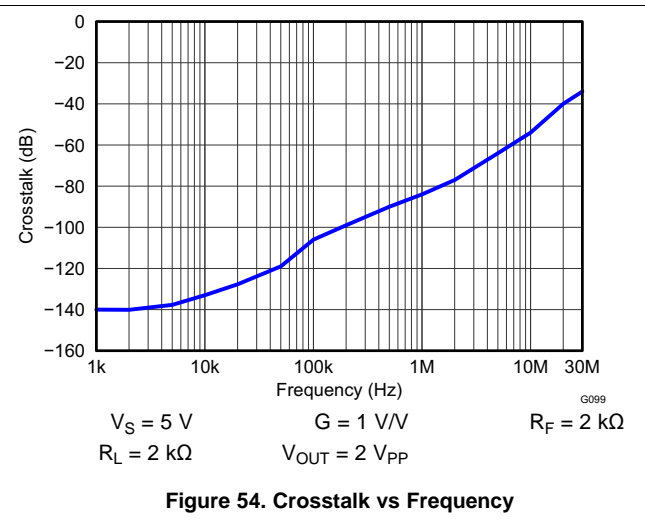
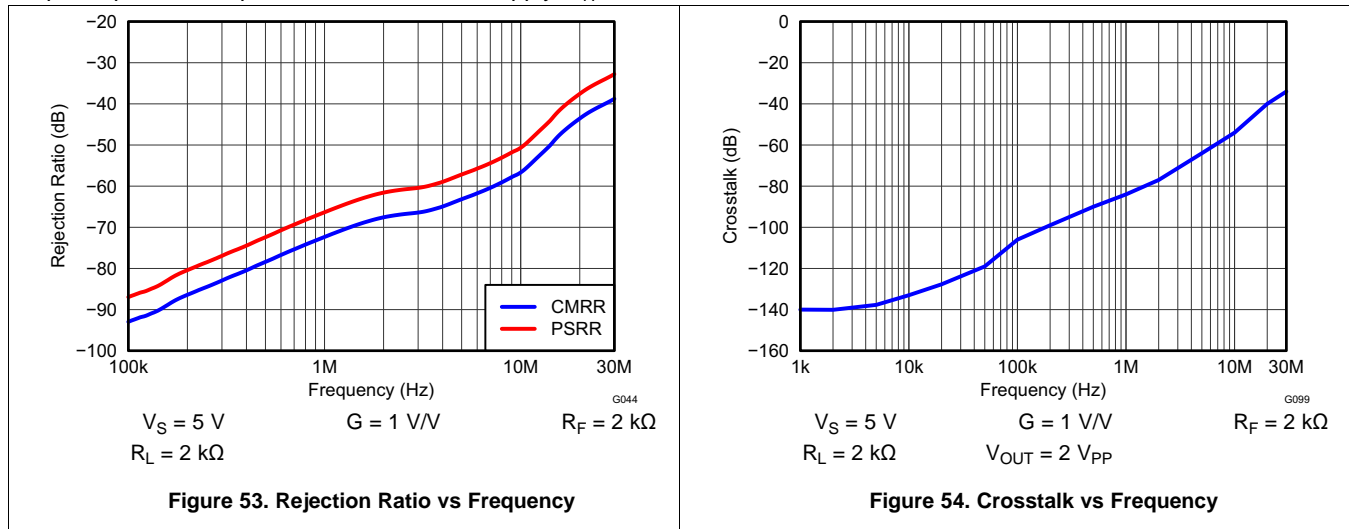

Figure 52.  $R_O$  vs  $C_{LOAD}$

**Typical Characteristics:  $V_S = 5\text{ V}$  (continued)**

$V_{S+} = 5\text{ V}$ ,  $V_{S-} = 0\text{ V}$ ,  $V_{OCM} = \text{open}$ ,  $V_{OUT} = 2\text{ V}_{pp}$ ,  $R_F = 2\text{ k}\Omega$ ,  $R_L = 2\text{ k}\Omega$  Differential,  $G = 1\text{ V/V}$ , Single-Ended Input, Differential Output, Input and Output Referenced to mid-supply,  $T_A = 25^\circ\text{C}$  unless otherwise noted.



Typical Characteristics:  $V_S = 5\text{ V}$  (continued)

$V_{S+} = 5\text{ V}$ ,  $V_{S-} = 0\text{ V}$ ,  $V_{OCM} = \text{open}$ ,  $V_{OUT} = 2\text{ V}_{pp}$ ,  $R_F = 2\text{ k}\Omega$ ,  $R_L = 2\text{ k}\Omega$  Differential,  $G = 1\text{ V/V}$ , Single-Ended Input, Differential Output, Input and Output Referenced to mid-supply,  $T_A = 25^\circ\text{C}$  unless otherwise noted.

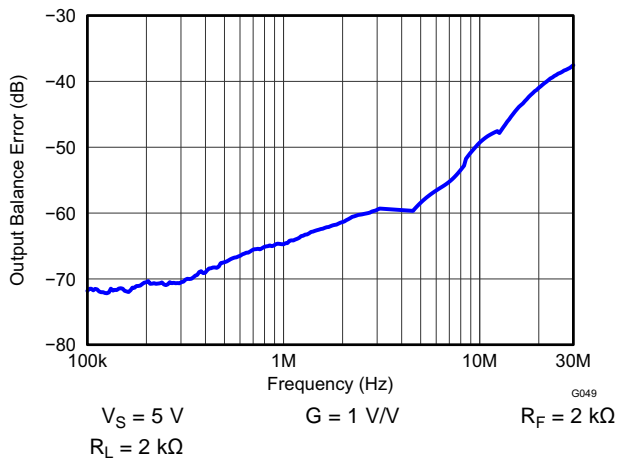

Figure 59. Output Balance Error vs Frequency

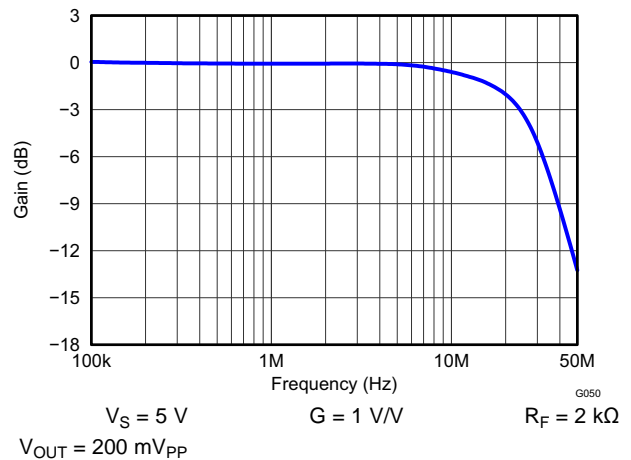

Figure 60.  $V_{OCM}$  Small-Signal Frequency Response

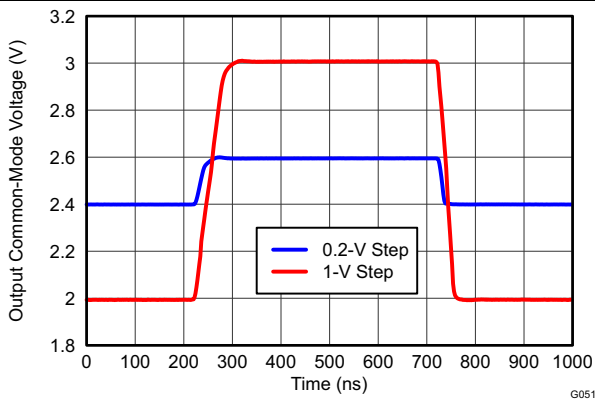

Figure 61.  $V_{OCM}$  Large- and Small Signal Pulse Response

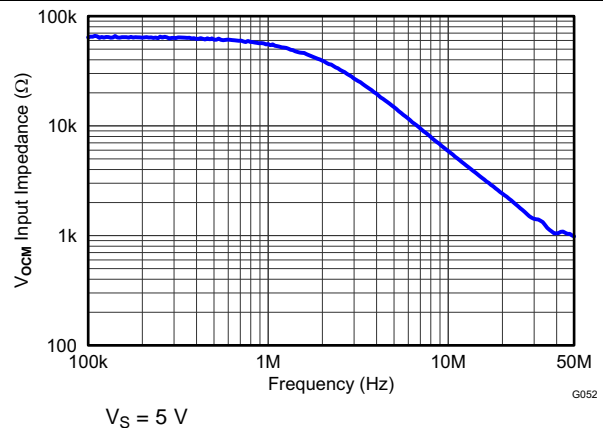

Figure 62.  $V_{OCM}$  Input Impedance vs Frequency

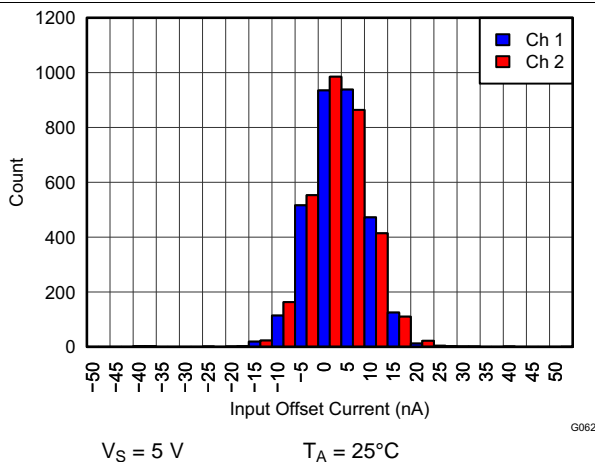

Figure 63. THS4532IPW Input Offset Current Histogram

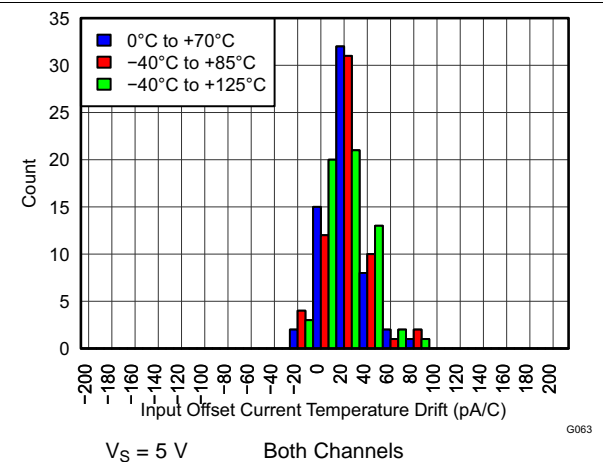

Figure 64. THS4532IPW Input Offset Current Temp Drift Histogram

Typical Characteristics:  $V_S = 5\text{ V}$  (continued)

$V_{S+} = 5\text{ V}$ ,  $V_{S-} = 0\text{ V}$ ,  $V_{OCM} = \text{open}$ ,  $V_{OUT} = 2\text{ V}_{pp}$ ,  $R_F = 2\text{ k}\Omega$ ,  $R_L = 2\text{ k}\Omega$  Differential,  $G = 1\text{ V/V}$ , Single-Ended Input, Differential Output, Input and Output Referenced to mid-supply,  $T_A = 25^\circ\text{C}$  unless otherwise noted.

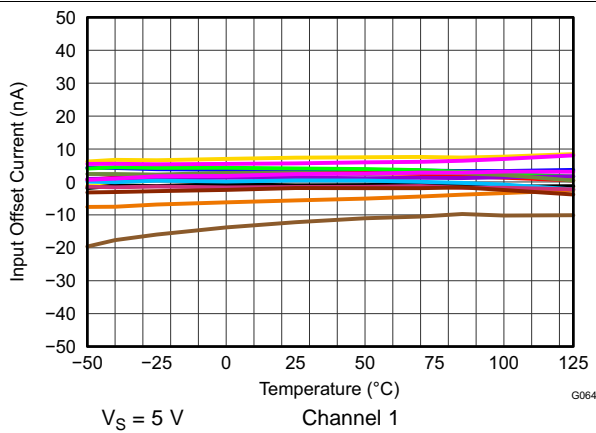

Figure 65. THS4532IPW Input Offset Current vs Temperature

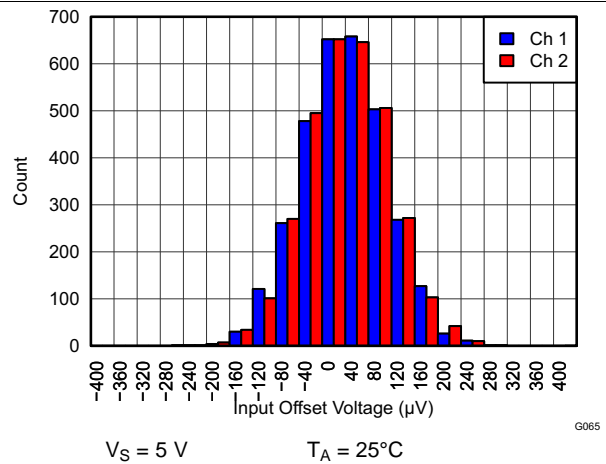

Figure 66. THS4532IPW Input Offset Voltage Histogram

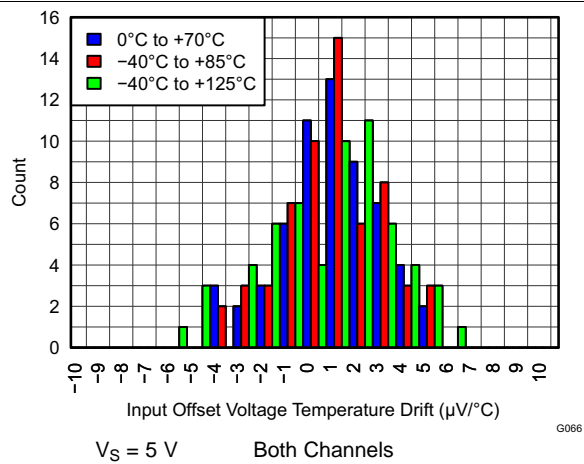

Figure 67. THS4532IPW Input Offset Voltage Temp Drift Histogram

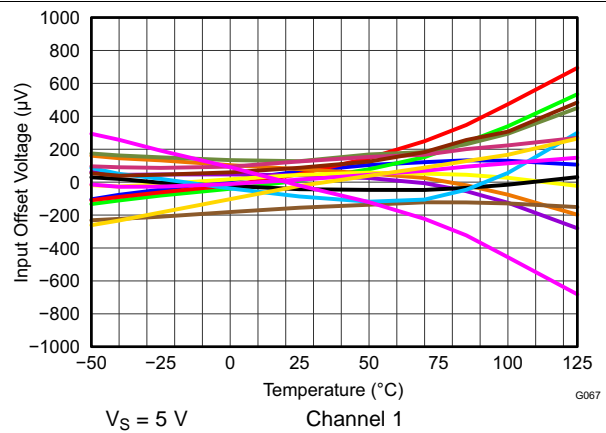

Figure 68. THS4532IPW Input Offset Voltage vs Temperature

## 8 Detailed Description

### 8.1 Overview

As shown in the [Functional Block Diagram](#), the THS4532 device is comprised of three functional blocks: a fully-differential amplifier with high open-loop gain of 114 dB, a servo amplifier to set the common-mode voltage of the output equal to the  $V_{OCM}$  input, and a power-down circuit to greatly reduce the power consumption when the device is idle.

The common-mode voltage servo has impressive performance specifications of  $\pm 1\%$  maximum gain error,  $\pm 5\text{-mV}$  maximum voltage offset, and 24-MHz bandwidth.

### 8.2 Functional Block Diagram

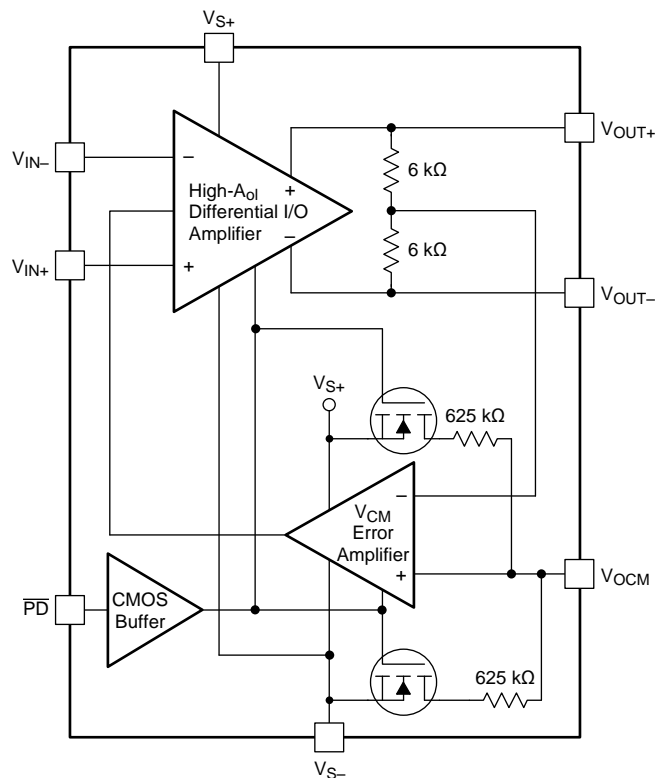

### 8.3 Feature Description

#### 8.3.1 Input Common-Mode Voltage Range

The input common-mode voltage of a fully-differential amplifier is the voltage at the positive and negative (+ and -) input pins of the amplifier.

Do not violate the input common-mode voltage range ( $V_{ICR}$ ) of the amplifier. Assuming the amplifier is in linear operation, the voltage across the input pins is only a few millivolts at most. Therefore, finding the voltage at one input pin determines the input common-mode voltage of the amplifier.

Use [公式 1](#) to calculate the voltage with the negative input as a summing node.

$$\left( V_{OUT+} \times \frac{R_G}{R_G + R_F} \right) + \left( V_{IN-} \times \frac{R_F}{R_G + R_F} \right) \quad (1)$$

To determine the  $V_{ICR}$  of the amplifier, the voltage at the negative input is evaluated at the extremes of  $V_{OUT+}$ .

As the gain of the amplifier increases, the input common-mode voltage becomes closer and closer to the input common-mode voltage of the source.

## Feature Description (接下页)

### 8.3.1.1 Setting the Output Common-Mode Voltage

The output common-mode voltage is set by the voltage at the  $V_{OCM}$  pin and the internal circuit works to maintain the output common-mode voltage as close as possible to this voltage. If left unconnected, the output common-mode is set to mid-supply by internal circuitry, which may be over-driven from an external source. 图 69 is representative of the  $V_{OCM}$  input. The internal  $V_{OCM}$  circuit has about 24-MHz of  $-3$ -dB bandwidth, which is required for best performance, but it is intended to be a DC bias input pin. Bypass capacitors are recommended on this pin to reduce noise. Use 公式 2 to calculate the external current required to overdrive the internal resistor divider.

$$I_{EXT} = \frac{2V_{OCM} - (V_{S+} + V_{S-})}{625 \text{ k}\Omega}$$

where

- $V_{OCM}$  is the voltage applied to the  $V_{OCM}$  pin. (2)



图 69. Simplified  $V_{OCM}$  Input Circuit

## Feature Description (接下页)

### 8.3.2 Power Down

The power down pin is internally connected to a CMOS stage which must be driven to a minimum of 2.1 V to ensure proper high logic.

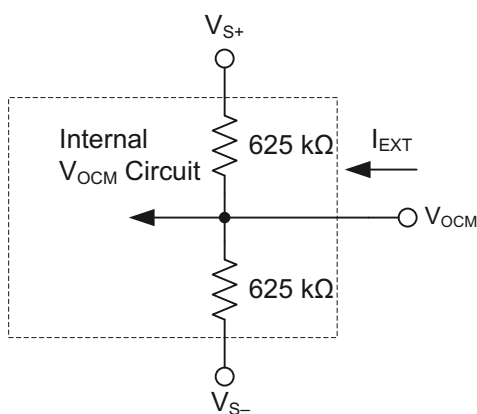

图 70. Simplified Power-Down Internal Circuit

If 1.8-V logic is used to drive the pin, a shoot through current of up to 100  $\mu\text{A}$  may develop in the digital logic causing the overall quiescent current to exceed the 2  $\mu\text{A}$  of maximum disabled quiescent current specified in the [Electrical Characteristics:  \$V\_S = 2.7\text{ V}\$](#) .

To properly interface to 1.8-V logic with minimal increase in additional current draw, a logic-level translator like the SN74AVC1T45 device can be used.

Alternatively, the same function can be achieved using a diode and pullup resistor as shown in 图 71.

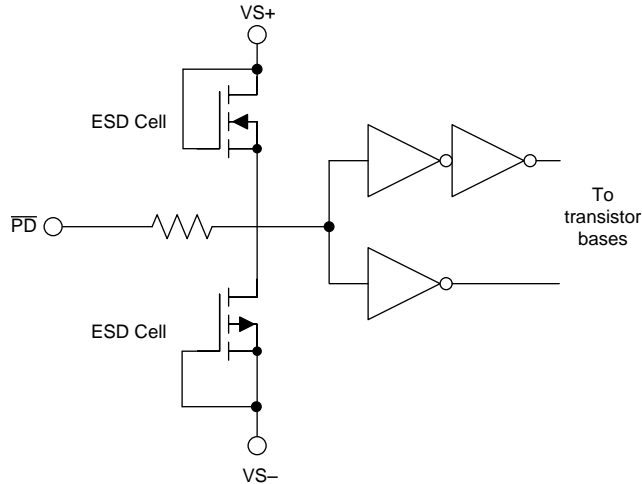

图 71. THS4532 Power Down Interface to 1.8-V Logic Microcontroller

The voltage at the power down pin will be a function of the supply voltage, input logic level, and diode drop. As long as the diode is forward biased, the power down voltage is calculated using 公式 3.

$$V_{PD} = V_L + V_f$$

where

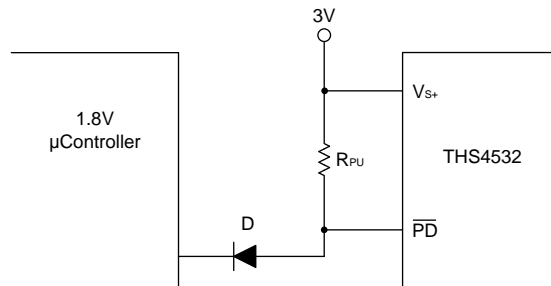
- $V_L$  is the logic level voltage.
- $V_f$  is the forward voltage drop across the diode. (3)

This means for 1.8-V logic, the forward voltage of the diode should be greater than 0.3 V but less than 0.7 V to keep the power down logic level above 2.1 V and less than 0.7 V respectively.

For example, if 1N914 is selected as the diode with a forward voltage of approximately 0.4 V, the translated logic voltages will be 0.4 V for disabled operation and 2.2 V for enabled operation.

## Feature Description (接下页)

Use [公式 4](#) to calculate the additional current draw.

$$i_{PD} = \frac{V_{CC} - (V_L + V_f)}{R_{PU}} \quad (4)$$

[公式 2](#) shows that larger values of RPU result in a smaller additional current. A reasonable value of RPU is 500 kΩ where an additional current draw of 5.2 μA is expected while the device is in operation and 1.6 μA when disabled.

### 8.4 Device Functional Modes

The THS4532 has two functional modes: full-power mode and power-down mode. The power-down mode reduces the quiescent current of the device to 500 nA from a typical value of 290 μA with a 5-V supply.

With a turnon time of only 600 ns and a turnoff time of 15 ns, the power-down mode can be used to greatly reduce the average power consumption of the device without sacrificing system performance.

## 9 Application and Implementation

### 注

Information in the following applications sections is not part of the TI component specification, and TI does not warrant its accuracy or completeness. TI's customers are responsible for determining suitability of components for their purposes. Customers should validate and test their design implementation to confirm system functionality.

### 9.1 Application Information

图 72 shows the general test circuit built on the EVM that was used for testing the THS4532. For simplicity, power supply decoupling is not shown – see [Layout](#) for recommendations. Depending on the test conditions, component values are changed per 表 4 and 表 5, or as otherwise noted. Some of the signal generators used are AC-coupled 50-Ω sources and a 0.22-μF capacitor and 49.9-Ω resistor to ground are inserted across  $R_{IT}$  on the un-driven or alternate input as shown to balance the circuit. A split-power supply is used to ease the interface to common lab test equipment, but if properly biased, the amplifier can be operated single-supply as described in the applications section with no impact on performance. For most of the tests, the devices are tested with single ended input and a transformer on the output to convert the differential output to single ended because common lab test equipment have single ended inputs and outputs. Performance is the same or better with differential input and differential output.



图 72. General Test Circuit

表 4. Gain Component Values for Single-Ended Input<sup>(1)</sup>

GAIN	$R_F$	$R_G$	$R_{IT}$
1 V/V	2 kΩ	2 kΩ	51.1 Ω
2 V/V	2 kΩ	1 kΩ	52.3 Ω
5 V/V	2 kΩ	392 Ω	53.6 Ω
10 V/V	2 kΩ	187 Ω	57.6 Ω

(1) Components are chosen to achieve gain and 50-Ω input termination. Resistor values shown are closest standard values so gains are approximate.

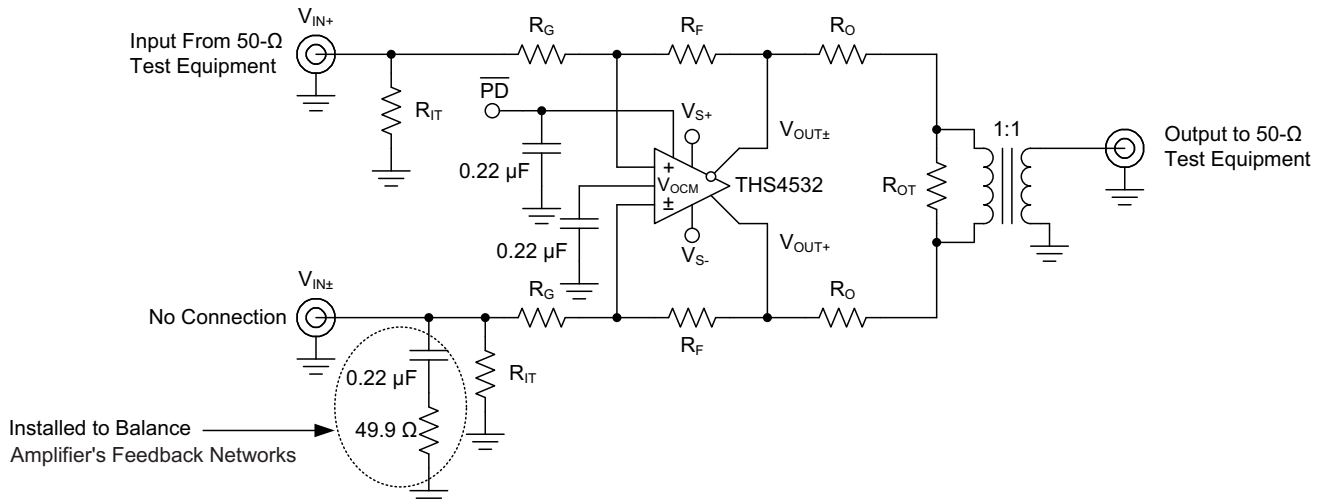
**表 5. Load Component Values For 1:1 Differential to Single-Ended Output Transformer<sup>(1)</sup>**

$R_L$	$R_O$	$R_{OT}$	ATTEN (dB)
100 $\Omega$	25 $\Omega$	open	6
200 $\Omega$	84.5 $\Omega$	71.5 $\Omega$	16.7
500 $\Omega$	237 $\Omega$	56.2 $\Omega$	25.6
1 k $\Omega$	487 $\Omega$	52.3 $\Omega$	31.8
2 k $\Omega$	976 $\Omega$	51.1 $\Omega$	38

(1) The total load includes 50- $\Omega$  termination by the test equipment. Components are chosen to achieve load and 50- $\Omega$  line termination through a 1:1 transformer. Resistor values shown are closest standard values so loads are approximate.

Because of the voltage divider on the output formed by the load component values, the output of the amplifier is attenuated. The column *ATTEN* in 表 5 shows the attenuation expected from the resistor divider. When using a transformer at the output as shown in 图 72, the signal has slightly more loss because of transformer insertion loss, and these numbers are approximate. The standard output load used for most tests is 2 k $\Omega$  with associated 38 dB of loss.

### 9.1.1 Frequency Response and Output Impedance

The circuit shown in 图 72 is used to measure the frequency response of the amplifier.

A network analyzer is used as the signal source and the measurement device. The output impedance of the network analyzer is 50  $\Omega$  and is AC coupled.  $R_{IT}$  and  $R_G$  are selected to impedance match to 50  $\Omega$  and maintain the proper gain. To balance the amplifier, a 49.9- $\Omega$  resistor and blocking capacitor to ground is inserted across  $R_{IT}$  on the alternate input.

The output is routed to the input of the network analyzer through 50- $\Omega$  coax. For a 2k load, 38 dB is added to the measurement to refer back to the output of the amplifier according to 表 5.

For output impedance, the signal is injected at  $V_{OUT}$  with  $V_{IN}$  left open. The voltage drop across the 2x  $R_O$  resistors is measured with a high impedance differential probe and used to calculate the impedance into the output of the amplifier.

### 9.1.2 Distortion

At 1 MHz and above, the circuit shown in 图 72 is used to measure harmonic, intermodulation distortion, and output impedance of the amplifier.

A signal generator is used as the signal source and the output is measured with a spectrum analyzer. The output impedance of the signal generator is 50  $\Omega$  and is AC coupled.  $R_{IT}$  and  $R_G$  are chosen to impedance match to 50  $\Omega$  and maintain the proper gain. To balance the amplifier, a 0.22- $\mu$ F capacitor and 49.9- $\Omega$  resistor to ground is inserted across  $R_{IT}$  on the alternate input. A low-pass filter is inserted in series with the input to reduce harmonics generated by the signal source. The level of the fundamental is measured and then a high-pass filter is inserted at the output to reduce the fundamental so it does not generate distortion in the input of the spectrum analyzer.

Distortion in the audio band is measured using an audio analyzer. Refer to the [Audio Performance](#) section for details.

### 9.1.3 Slew Rate, Transient Response, Settling Time, Overdrive, Output Voltage, and Turnon and Turnoff Time

The circuit shown in 图 73 is used to measure slew rate, transient response, settling time, overdrive recovery, and output voltage swing. Turnon and turnoff times are measured with 50- $\Omega$  input termination on the PD input, by replacing the 0.22- $\mu$ F capacitor with 49.9- $\Omega$  resistor.



图 73. Slew Rate, Transient Response, Settling Time,  $Z_O$ , Overdrive Recovery,  $V_{OUT}$  Swing, and Turn-On and Turn-Off Test Circuit

### 9.1.4 Common-Mode and Power Supply Rejection

The circuit shown in 图 74 is used to measure the CMRR. The signal from the network analyzer is applied common-mode to the input.

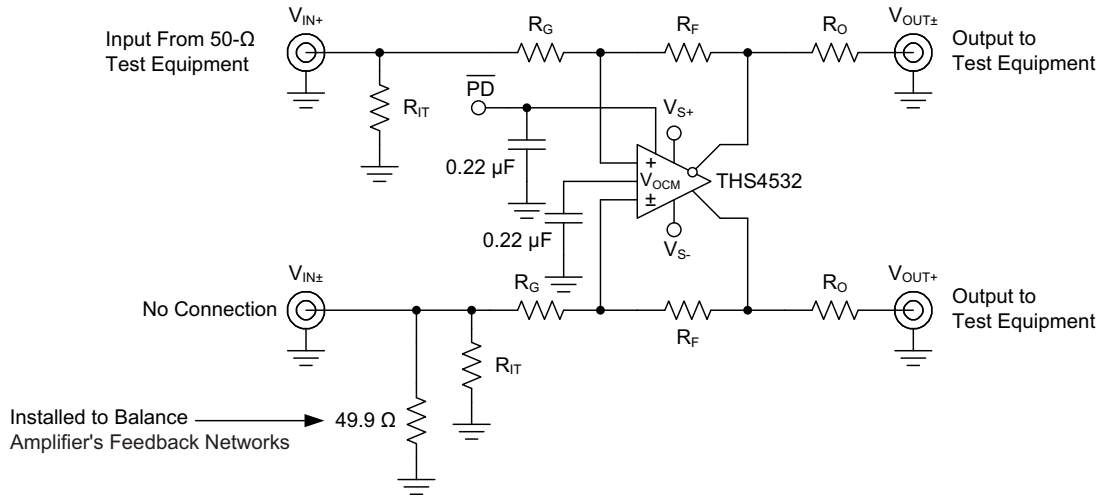

图 74. CMRR Test Circuit

图 75 is used to measure the PSRR of  $V_{S+}$  and  $V_{S-}$ . The power supply is applied to the network DC offset input of the analyzer. For both CMRR and PSRR, the output is probed using a high impedance differential probe across  $R_{OT}$ . The calculated CMRR and PSRR are referred to the input of the device.

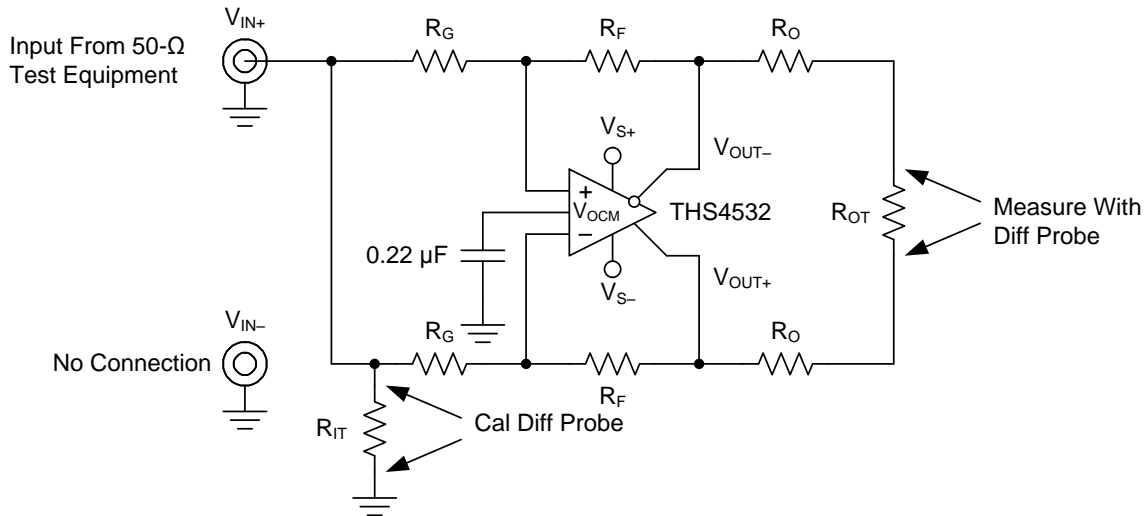

图 75. PSRR Test Circuit

### 9.1.5 V<sub>OCM</sub> Input

The circuit shown in 图 76 is used to measure the transient response, frequency response, and input impedance of the V<sub>OCM</sub> input. For these tests, the cal point is across the 49.9 Ω V<sub>OCM</sub> termination resistor. Transient response and frequency response are measured with R<sub>CM</sub> = 0 Ω and using a high impedance differential probe at the summing junction of the two R<sub>O</sub> resistors, with respect to ground. The input impedance is measured using a high impedance differential probe at the V<sub>OCM</sub> pin and the drop across R<sub>CM</sub> is used to calculate the impedance into the V<sub>OCM</sub> input of the amplifier.

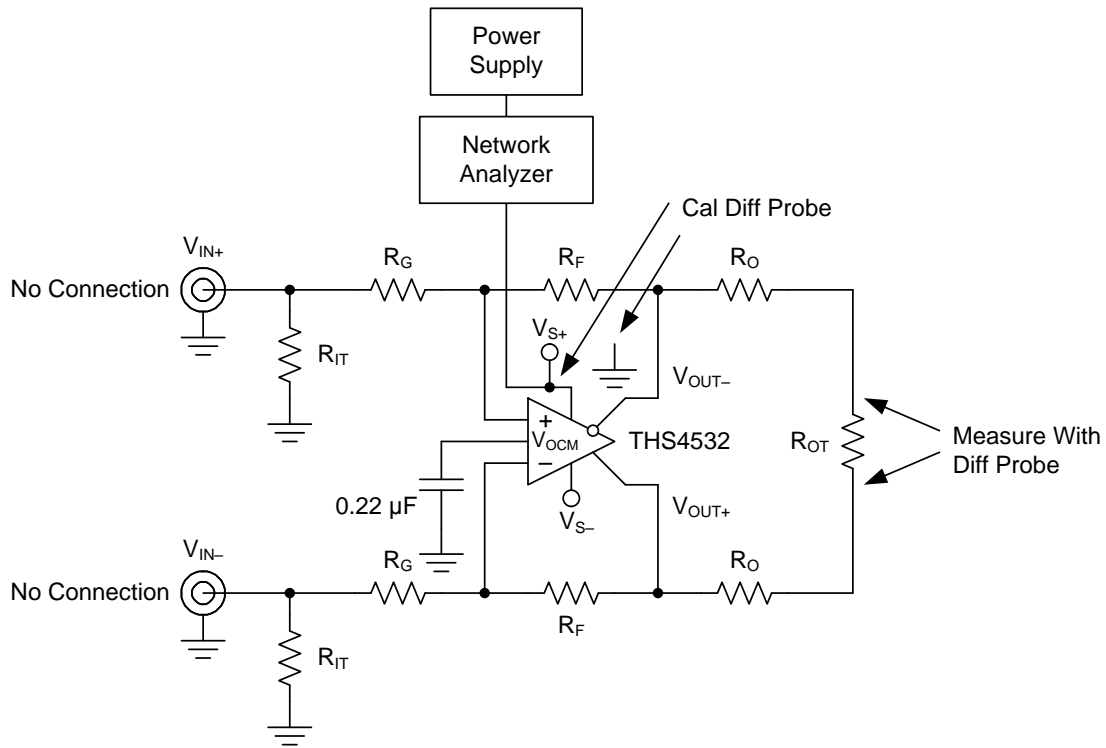

图 76. V<sub>OCM</sub> Input Test Circuit

### 9.1.6 Balance Error

The circuit shown in 图 77 is used to measure the balance error of the main differential amplifier. A network analyzer is used as the signal source and the measurement device. The output impedance of the network analyzer is  $50\ \Omega$  and is DC coupled.  $R_{IT}$  and  $R_G$  are chosen to impedance match to  $50\ \Omega$  and maintain the proper gain. To balance the amplifier, a  $49.9\text{-}\Omega$  resistor to ground is inserted across  $R_{IT}$  on the alternate input. The output is measured using a high impedance differential probe at the summing junction of the two  $R_O$  resistors, with respect to ground.

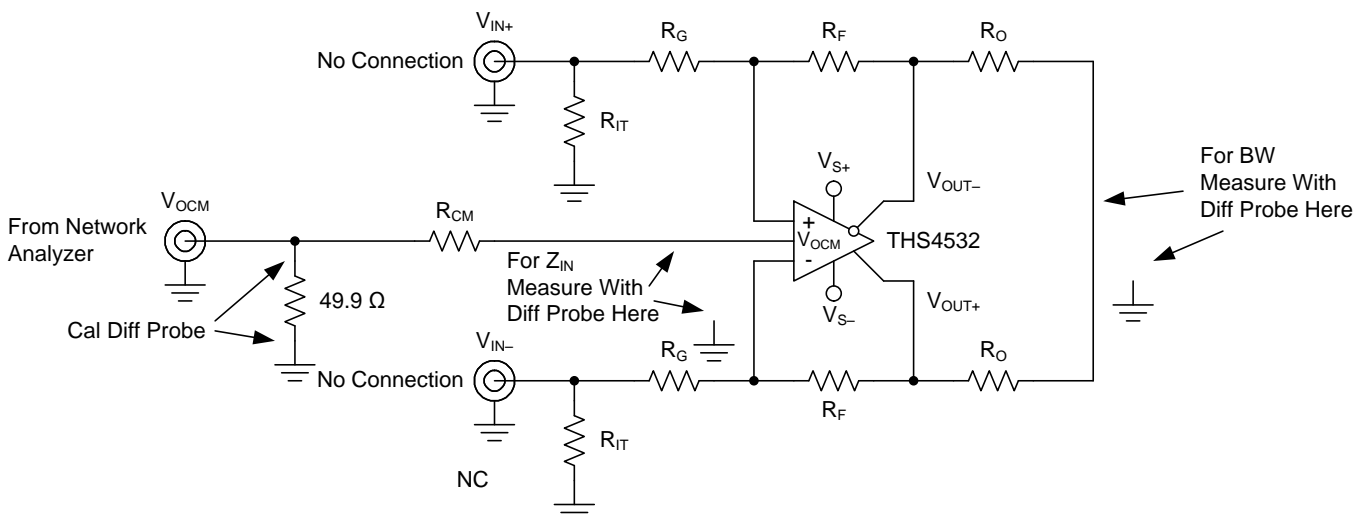

图 77. Balance Error Test Circuit

### 9.1.7 Single-Supply Operation

To facilitate testing with common lab equipment, the THS4532 EVM is built to allow for split-supply operation and most of the data presented in this data sheet was taken with split-supply power inputs. The device is designed for use with single-supply power operation and can easily be used with single-supply power without degrading the performance. The only requirement is to bias the device properly and the specifications in this data sheet are given for single supply operation.

### 9.1.8 Low-Power Applications and the Effects of Resistor Values on Bandwidth

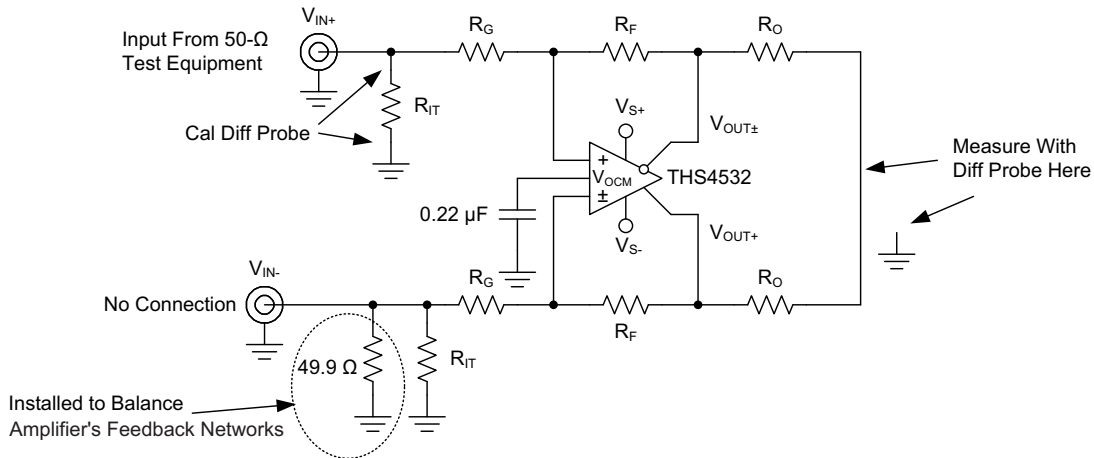
The THS4532 is designed for the nominal value of  $R_F$  to be  $2\text{ k}\Omega$ . This gives excellent distortion performance, maximum bandwidth, best flatness, and best pulse response. It also loads the amplifier. For example; in gain of 1 with  $R_F = R_G = 2\text{ k}\Omega$ ,  $R_G$  to ground, and  $V_{OUT+} = 4\text{ V}$ ,  $1\text{ mA}$  of current will flow through the feedback path to ground. In low power applications, reducing this current is desirable by increasing the gain setting resistors values. Using larger value gain resistors has three primary side effects (other than lower power) because of the interaction with the device and PCB parasitic capacitance:

- Lowers the bandwidth.
- Lowers the phase margin.
  - This causes peaking in the frequency response.
  - This also causes overshoot and ringing in the pulse response.
- Increases the output noise.

图 78 shows the small signal frequency response for gain of 1 with  $R_F$  and  $R_G$  equal to  $2\text{ k}\Omega$ ,  $10\text{ k}\Omega$ , and  $100\text{ k}\Omega$ . The test was done with  $R_L = 2\text{ k}\Omega$ . Because of loading effects of  $R_L$ , lower values may reduce the peaking, but higher values will not have a significant effect.

As expected, larger value gain resistors cause lower bandwidth and peaking in the response (peaking in frequency response is synonymous with overshoot and ringing in pulse response). These effects are caused by the feedback pole created by the summing-junction capacitance and these larger  $R_f$  values.



图 78. THS4532 Frequency Response with Various Gain Setting Resistor Values

### 9.1.9 Driving Capacitive Loads

The THS4532 is designed for a nominal parasitic capacitive load of 2 pF (differentially). When driving capacitive loads greater than this, TI recommends using small resistors ( $R_O$ ) in series with the output as close to the device as possible. Without  $R_O$ , capacitance on the output interacts with the output impedance of the amplifier causing phase shift in the loop gain of the amplifier that reduces the phase margin resulting in:

- Peaking in the frequency response.
- Overshoot, undershoot, and ringing in the time domain response with a pulse or square-wave signal.
- May lead to instability or oscillation.

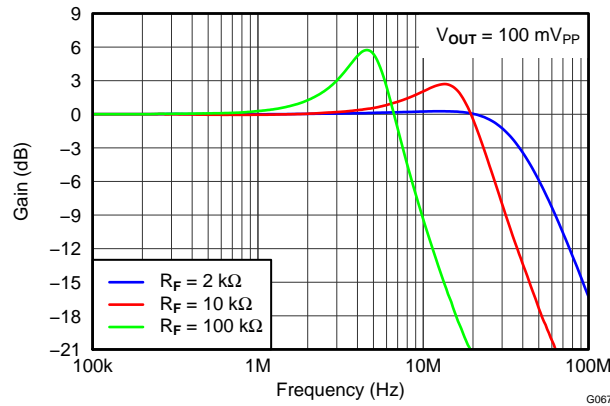
Inserting  $R_O$  compensates the phase shift and restores the phase margin, but it also limits bandwidth. The circuit shown in 图 73 is used to test for best  $R_O$  versus capacitive loads,  $C_L$ , with a capacitance placed differential across the  $V_{OUT+}$  and  $V_{OUT-}$  along with 2-k $\Omega$  load resistor, and the output is measure with a differential probe. 图 79 shows the suggested values of  $R_O$  versus capacitive loads,  $C_L$ , and 图 80 shows the frequency response with various values. Performance is the same on both 2.7-V and 5-V supply.



图 79. Recommended Series Output Resistor vs Capacitive Load for Flat Frequency Response



图 80. Frequency Response for Various  $R_O$  and  $C_L$  Values

### 9.1.10 Audio Performance

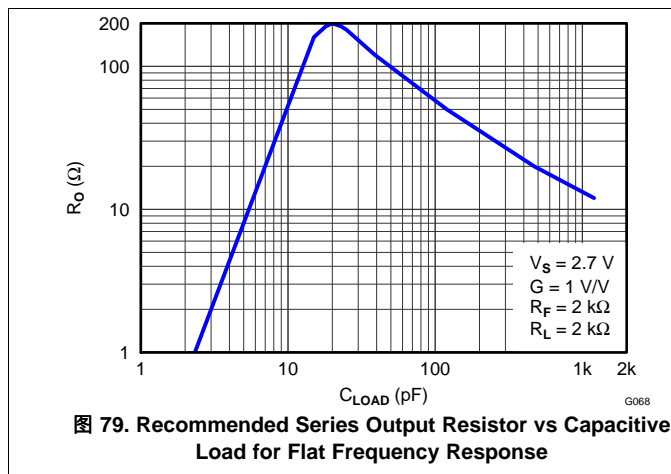
The THS4532 provides excellent audio performance with very low quiescent power. To show performance in the audio band, the device was tested with an audio analyzer. THD+N and FFT tests were run at 1-V<sub>rms</sub> output voltage. Performance is the same on both 2.7-V and 5-V supply. 图 81 is the test circuit used, and 图 82 and 图 83 show performance of the analyzer. In the FFT plot the harmonic spurs are at the testing limit of the analyzer, which means the THS4532 is actually much better than can be directly measured. Because the THS4532 distortion performance cannot be directly measured in the audio band it is estimated from measurement in high noise gain configuration correlated with simulation.

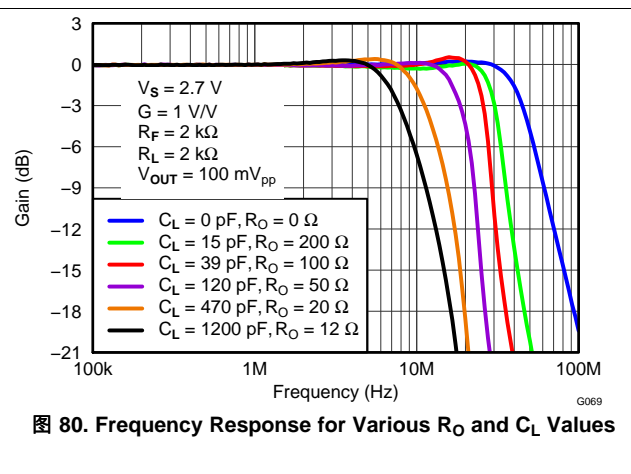

图 81. THS4532 Audio Analyzer Test Circuit



图 82. THD+N on Audio Analyzer, 10 Hz to 24 kHz

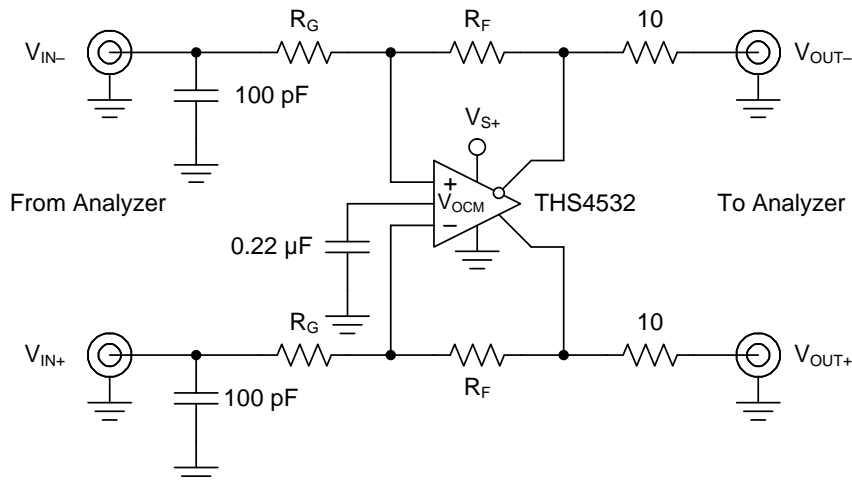

图 83. 1-kHz FFT Plot on Audio Analyzer

### 9.1.11 Audio On and Off Pop Performance

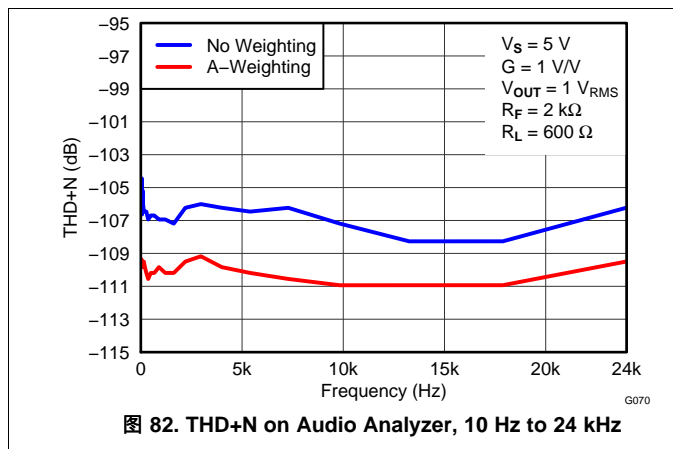
The THS4532 is tested to show on and off pop performance by connecting a speaker between the differential outputs and switching on and off the power supply, and also by using the power down function of the THS4532. Testing was done with and without tones. During these tests no audible pop could be heard.

With no input tone, 图 84 shows the voltage waveforms when switching power on to the THS4532 and 图 85 shows voltage waveforms when turning power off. The transients during power on and off show no audible pop should be heard.

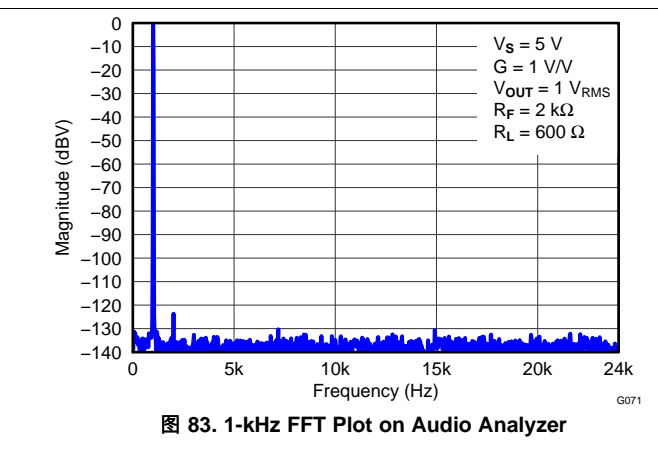
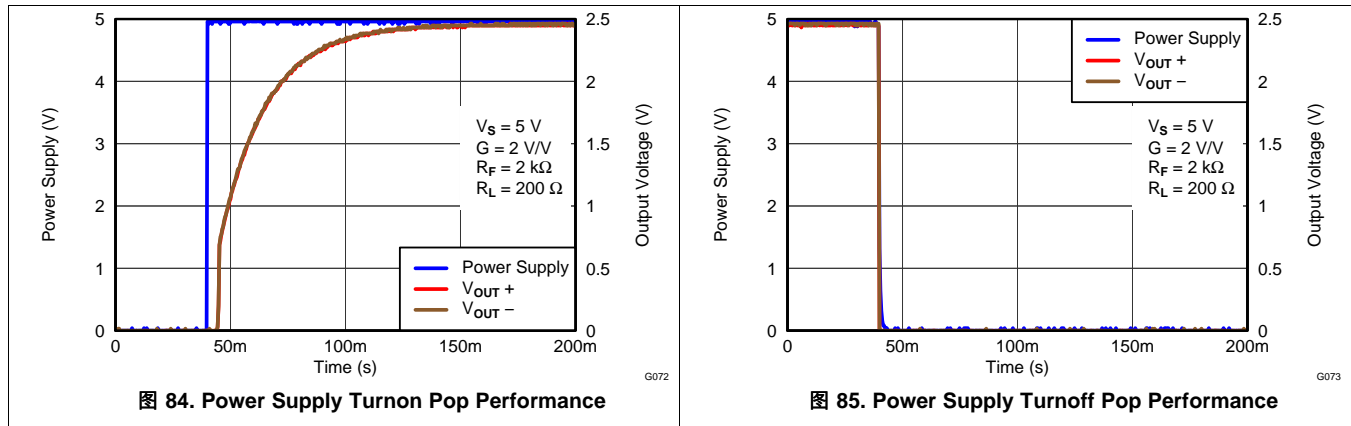

With no input tone, 图 86 shows the voltage waveforms using the  $\overline{\text{PD}}$  pin to enable and disable the THS4532. The transients during power on and off show no audible pop should be heard.

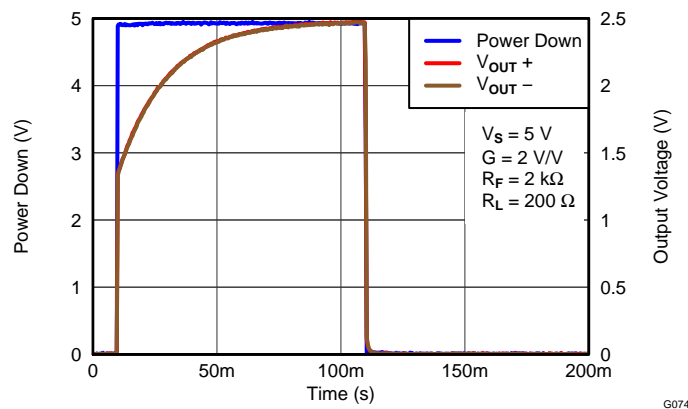

## 9.2 Typical Applications

The following circuits show application information for the THS4532. For simplicity, power-supply decoupling capacitors are not shown in these diagrams; see the [Layout Guidelines](#) section for suggested guidelines. For more details on the use and operation of fully-differential amplifiers, refer to the Application Report *Fully-Differential Amplifiers (SLOA054)*, available for download from the TI website at [www.ti.com](http://www.ti.com).

### 9.2.1 SAR ADC Performance: THS4532 and ADS8321 Combined Performance



图 87. THS4532 and ADS8321 Test Circuit

#### 9.2.1.1 Design Requirements

To show achievable performance with a high performance SAR ADC, the THS4532 is tested as the drive amplifier for the ADS8321. The ADS8321 is a 16-bit, SAR ADC that offers excellent AC and DC performance, with ultra-low power and small size. The circuit shown in 图 87 is used to test the performance. Data was taken using the ADS8321 at 100 kSPS with input frequency of 10 kHz and signal levels 0.5 dB below full scale. The FFT plot of the spectral performance is in 图 88. A summary of the FFT analysis results are in 表 6 along with ADS8321 typical data sheet performance at  $f_s = 100$  kSPS. Refer to its data sheet for more information.

#### 9.2.1.2 Detailed Design Procedure

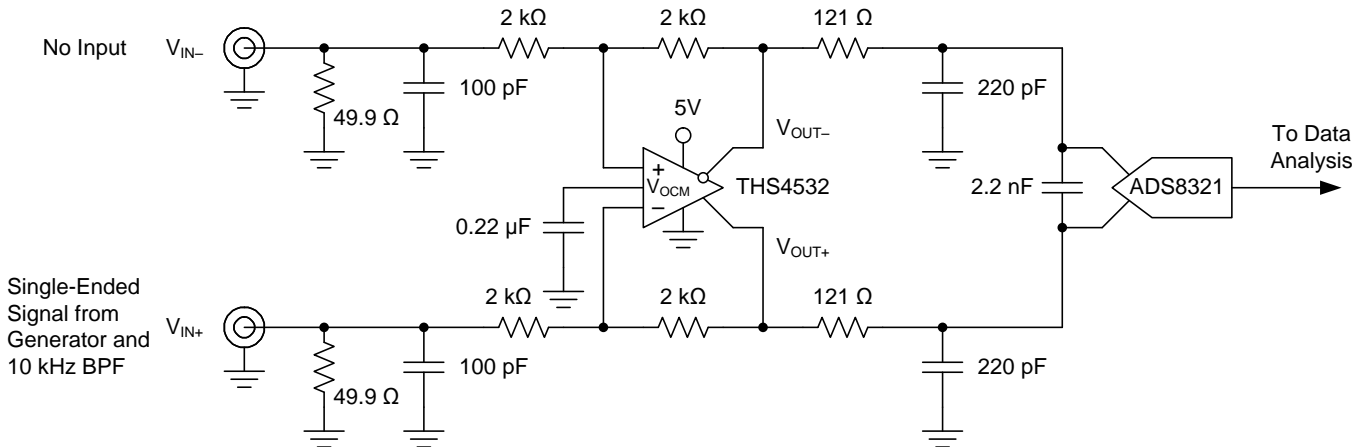
The standard ADS8321 EVM and THS4532 EVM are modified to implement the schematic in 图 87 and used to test the performance of the THS4532 as a drive amplifier. With single supply +5-V supply the output common-mode of the THS4532 defaults to +2.5 V as required at the input of the ADS8321 so the  $V_{OCM}$  input of the THS4532 simply bypassed to GND with 0.22- $\mu$ F capacitor. The summary of results of the FFT analysis versus typical data sheet performance shown in 表 6 show that the THS4532 will make an excellent drive amplifier for this ADC.

**Typical Applications (接下页)**

**9.2.1.3 Application Curve**

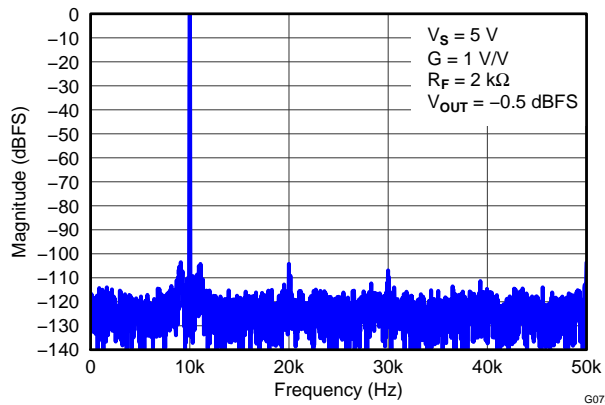

**图 88. THS5432 + ADS8321 1-kHz FFT**

**表 6. 10-kHz FFT Analysis Summary**

CONFIGURATION	TONE	SIGNAL	SNR	THD	SINAD	SFDR
THS5432 + ADS8321	10 kHz	-0.5 dBFS	87 dBc	-96 dBc	87 dBc	100 dBc
ADS8321 Data Sheet (typical)	10 kHz	-0.5 dBFS	87 dBc	-86 dBc	84 dBc	86 dBc

**9.2.2 Audio ADC Driver Performance: THS4532 and PCM4204 Combined Performance**

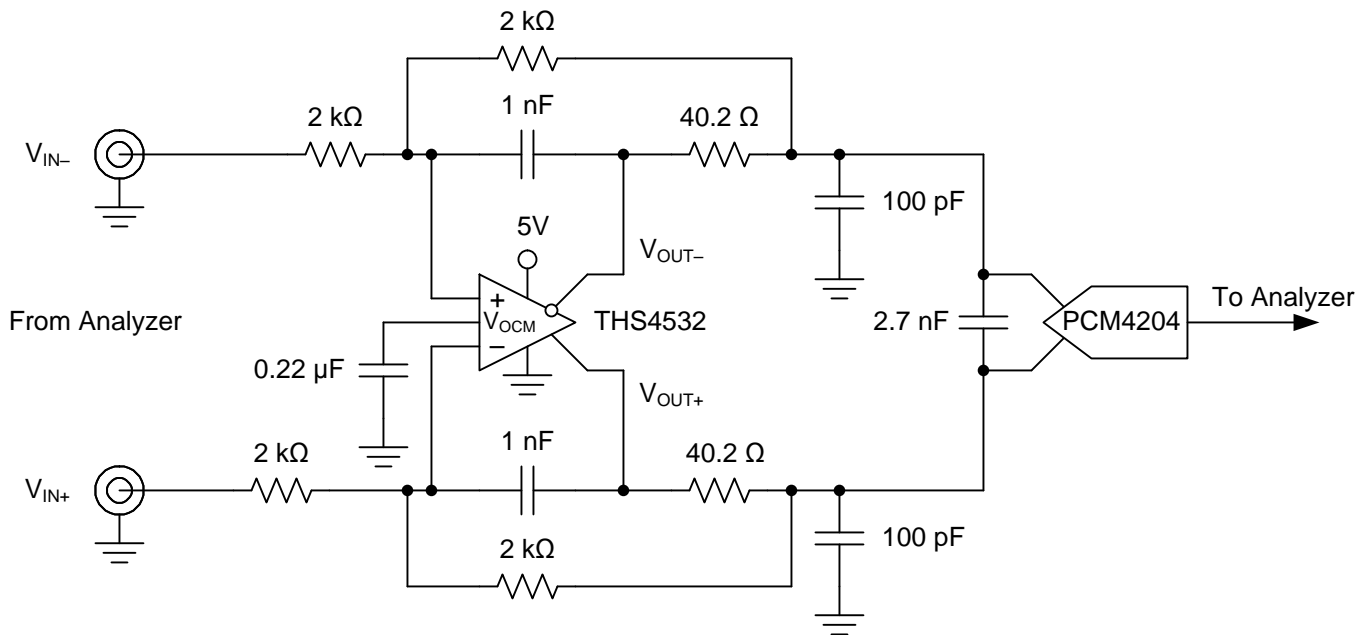

**图 89. THS4532 and PCM4204 Test Circuit**

### 9.2.2.1 Design Requirements

To show achievable performance with a high performance audio ADC, the THS5432 is tested as the drive amplifier for the PCM4204. The PCM4204 is a high-performance, four-channel analog-to-digital converter (ADC) designed for professional and broadcast audio applications. The PCM4204 architecture uses a 1-bit delta-sigma modulator per channel incorporating an advanced dither scheme for improved dynamic performance, and supports PCM output data. The PCM4204 provides flexible serial port interface and many other advanced features. Refer to the PCM4204 data sheet for more information. 图 89 shows the circuit.

### 9.2.2.2 Detailed Design Procedure

The PCM4204 EVM is used to test the audio performance of the THS5432 as a drive amplifier. The standard PCM4204 EVM is provided with 4x OPA1632 fully-differential amplifiers, which use the same pin out as the THS5432. For testing, one of these amplifiers is replaced with a THS5432 device in same package (MSOP), gain changed to 1 V/V, and power supply changed to single supply 5 V. With single supply +5-V supply the output common-mode of the THS5432 defaults to 2.5 V as required at the input of the PCM4204. So the resistor connecting the  $V_{OCM}$  input of the THS5432 to the input common-mode drive from the PCM4204 is optional and no performance change was noted with it connected or removed. The EVM power connections were modified by connecting positive supply inputs, 15 V, 5 VA, and 5 VD, to a 5-V external power supply (EXT 3.3 was not used) and connecting -15 V and all ground inputs to ground on the external power supply so only one external 5-V supply was needed to power all devices on the EVM.

An audio analyzer is used to provide an analog audio input to the EVM and the PCM formatted digital output is read by the digital input on the analyzer. Data was taken at  $f_s = 96$  kHz, and audio output uses PCM format. Other data rates and formats are expected to show similar performance in line with that shown in the data sheet.

### 9.2.2.3 Application Curves

图 90 shows the THD+N vs Frequency with no weighting and 图 91 shows an FFT with 1-kHz input tone. Input signal to the PCM4204 for these tests is -0.5 dBFS. 表 7 summarizes results of testing using the THS5432 + PCM4204 versus typical Data Sheet performance, and show it make an excellent drive amplifier for this ADC.



表 7. 1-kHz AC Analysis: Test Circuit versus PCM4204 Data Sheet Typical Specifications ( $f_s = 96$  KSPS)

CONFIGURATION	TONE	THD + N
THS5432 + PCM4204	1 kHz	-106 dB
PCM4204 Data Sheet (typical)	1 kHz	-103 dB

### 9.2.3 SAR ADC Performance: THS4532 and ADS7945 Combined Performance

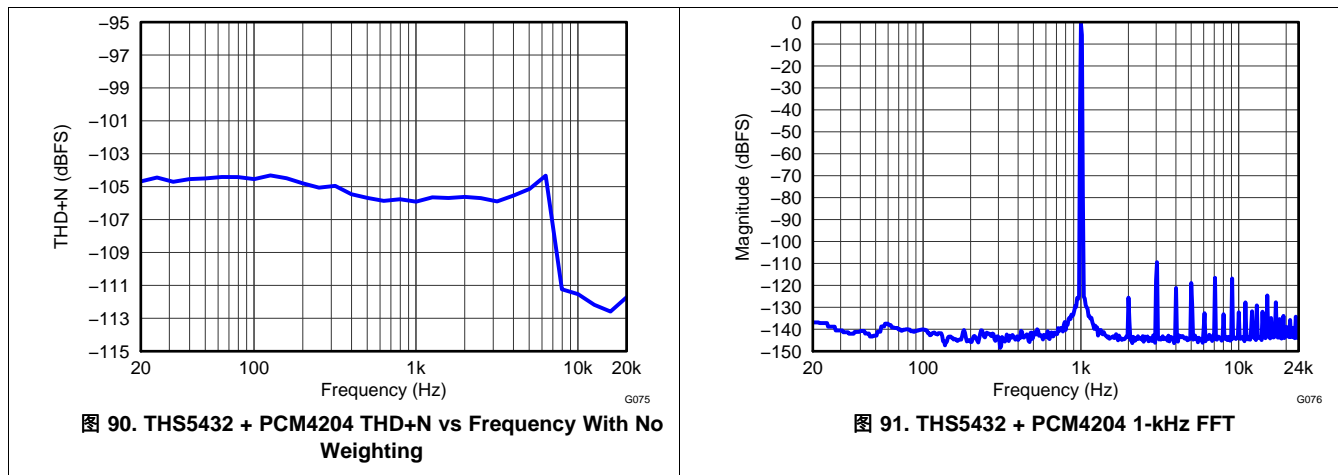

图 92. THS4532 and ADS7945 Test Circuit

#### 9.2.3.1 Design Requirements

To show achievable performance with a high performance SAR ADC, the THS4532 is tested as the drive amplifier for the ADS7945. The ADS7945 is a 14-bit, SAR ADC that offers excellent AC and DC performance, with low power and small size. The circuit shown in 图 92 is used to test the performance. Data was taken using the ADS7945 at 2MSPS with input frequency of 10 kHz and signal level 0.5 dB below full scale. The FFT plot of the spectral performance is in 图 93. A summary of the FFT analysis results are in 表 8 along with ADS7945 typical data sheet performance at  $f_s = 2$  MSPS. Refer to the data sheet for more information.

#### 9.2.3.2 Detailed Design Procedure

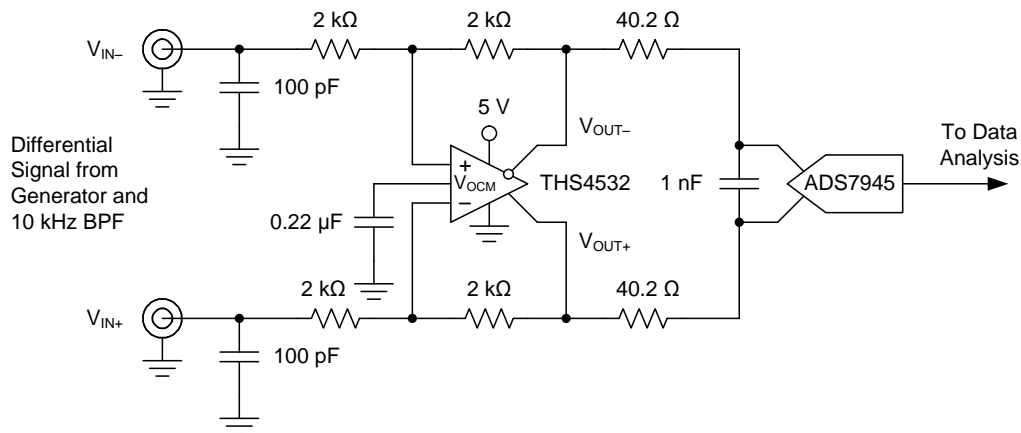
The standard ADS7945 EVM and THS4532 EVM are modified to implement the schematic in 图 92 and used to test the performance of the THS4532 as a drive amplifier. With single supply 5 V supply the output common-mode of the THS4532 defaults to +2.5 V as required at the input of the ADS7945 so the  $V_{OCM}$  input of the THS4532 simply bypassed to GND with 0.22- $\mu$ F capacitor. The summary of results of the FFT analysis versus typical data sheet performance shown in 表 8 show that the THS4532 will make an excellent drive amplifier for this ADC.

#### 9.2.3.3 Application Curve



图 93. THS4532 and ADS7945 Test Circuit

表 8. 10-kHz FFT Analysis Summary

CONFIGURATION	TONE	SIGNAL	SNR	THD	SFDR
THS4532 + ADS7945	10 kHz	-0.5 dBFS	83 dBc	-93 dBc	96 dBc
ADS7945 Data Sheet (typ)	10 kHz	-0.5 dBFS	84 dBc	-92 dBc	94 dBc

### 9.3 Systems Examples

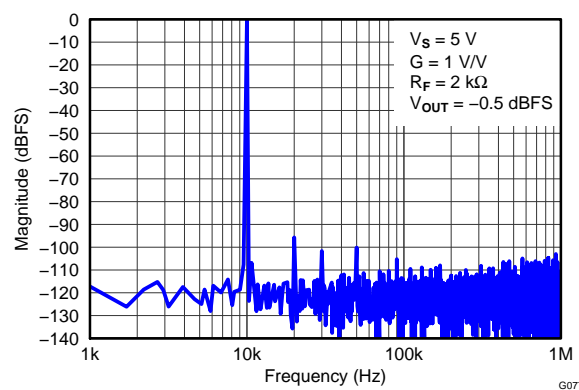
#### 9.3.1 Differential-Input to Differential-Output Amplifier

The THS4532 is a fully-differential amplifier and can be used to amplify differential input signals to differential output signals. A basic block diagram of the circuit is shown in 图 94 ( $V_{OCM}$  and  $\overline{PD}$  inputs not shown). The gain of the circuit is set by  $R_F$  divided by  $R_G$ .



图 94. Differential Input to Differential Output Amplifier

##### 9.3.1.1 AC-Coupled, Differential-Input to Differential-Output Design Issues

There are two typical ways to use the THS4532 family with an AC-coupled differential source. In the first method, the source is differential and can be coupled in through two blocking capacitors. The second method uses either a single-ended or a differential source and couples in through a transformer (or balun). 图 95 shows a typical blocking capacitor approach to a differential input. An optional differential-input termination resistor ( $R_M$ ) is included in this design. This  $R_M$  element allows the input  $R_G$  resistors to be scaled up while still delivering lower differential input impedance to the source. In this example, the  $R_G$  elements sum to show a 500- $\Omega$  differential impedance, while the  $R_M$  element combines in parallel to give a net 100- $\Omega$ , AC-coupled, differential impedance to the source. Again, the design proceeds ideally by selecting the  $R_F$  element values, then the  $R_G$  to set the differential gain, then an  $R_M$  element (if needed) to achieve the target input impedance. Alternatively, the  $R_M$  element can be eliminated, the  $R_G$  elements set to the desired input impedance, and  $R_F$  set to the get the differential gain ( $R_F / R_G$ ).

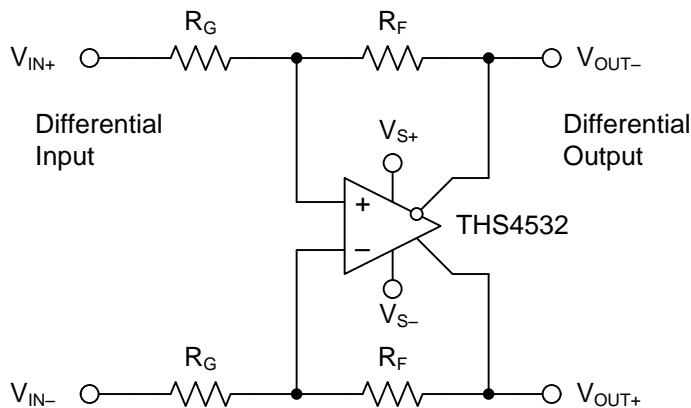

图 95. Example Down-Converting Mixer Delivering an AC-Coupled Differential Signal to the THS4532

The DC biasing here is very simple. The output  $V_{OCM}$  is set by the input control voltage; and because there is no DC-current path for the output common-mode voltage, that DC bias also sets the input pins common-mode operating points.

## Systems Examples (接下页)

### 9.3.2 Single-Ended to Differential FDA Configuration

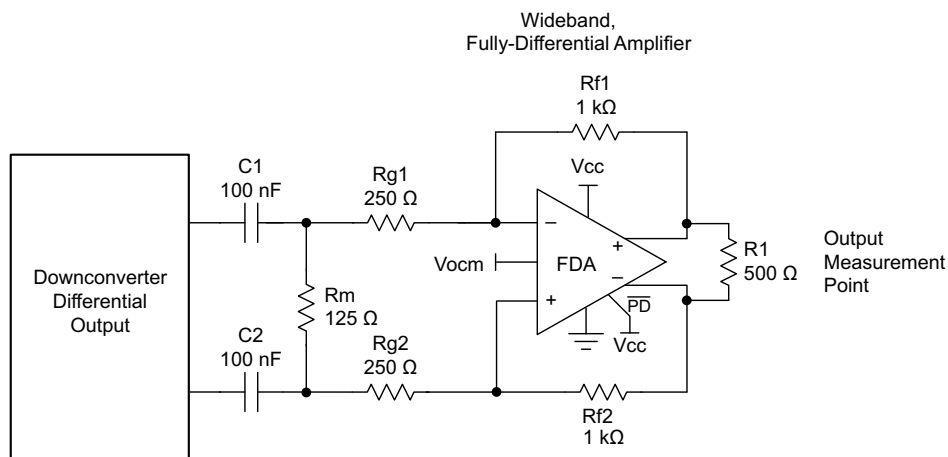
#### 9.3.2.1 Input Impedance

The designs so far have included a source impedance,  $R_S$ , that must be matched by  $R_T$  and  $R_{G1}$ . The total impedance at the junction of  $R_T$  and  $R_{G1}$  for the circuit of 图 99 is the parallel combination of  $R_T$  to ground, and the  $Z_A$  (active impedance) presented by  $R_{G1}$ . The expression for  $Z_A$ , assuming  $R_{G2}$  is set to obtain the differential divider balance, is given by 公式 5:

$$Z_A = R_{G1} \frac{\left(1 + \frac{R_{G1}}{R_{G2}}\right) \left(1 + \frac{R_F}{R_{G1}}\right)}{2 + \frac{R_F}{R_{G2}}} \tag{5}$$

For designs that do not need impedance matching, for instance where the input is driven from the low-impedance output of another amplifier,  $R_{G1} = R_{G2}$  is the single-to-differential design used without an  $R_T$  to ground. Setting  $R_{G1} = R_{G2} = R_G$  in 公式 5 produces 公式 6, which is the input impedance of a simple-input FDA driven from a low-impedance, single-ended source.

$$Z_A = 2R_G \frac{\left(1 + \frac{R_F}{R_G}\right)}{2 + \frac{R_F}{R_G}} \tag{6}$$

In this case, setting a target gain as  $R_F / R_G \equiv \alpha$ , and then setting the desired input impedance allows the  $R_G$  element to be resolved first. Then the  $R_F$  is set to get the target gain. For example, targeting an input impedance of 200  $\Omega$  with a gain of 4 V/V, 公式 7 calculates the  $R_G$  value. Multiplying this required  $R_G$  value by a gain of 4 gives the  $R_F$  value and the design of 图 96.

$$R_G = Z_A \frac{2 + \alpha}{2(1 + \alpha)} \tag{7}$$



图 96. 200- $\Omega$  Input Impedance, Single-Ended to Differential DC-Coupled Design With Gain of 4 V/V

After being designed, this circuit can also be AC-coupled by adding blocking caps in series with the two 120- $\Omega$   $R_G$  resistors. This active input impedance has the advantage of increasing the apparent load to the prior stage using lower resistors values, leading to lower output noise for a given gain target.

**Systems Examples (接下页)**

**9.3.3 Single-Ended Input to Differential Output Amplifier**

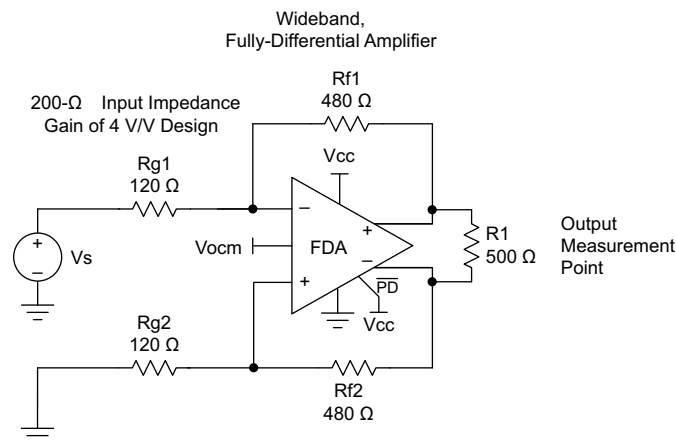
The THS4532 can also be used to amplify and convert single-ended input signals to differential output signals. A basic block diagram of the circuit is shown in 图 97 ( $V_{OCM}$  and  $\overline{PD}$  inputs not shown). The gain of the circuit is again set by  $R_F$  divided by  $R_G$ .

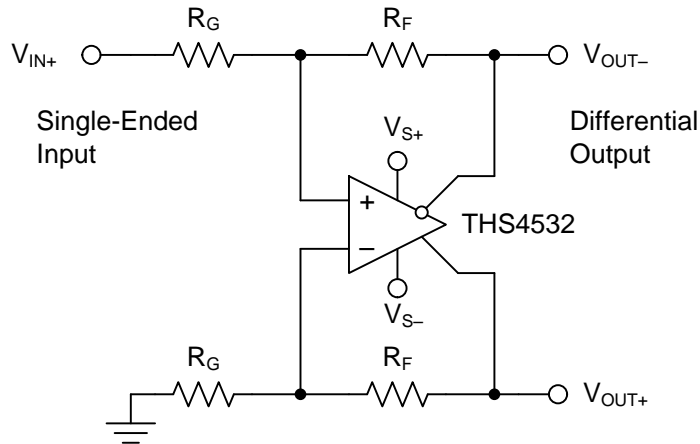

**图 97. Single-Ended Input to Differential Output Amplifier**

## Systems Examples (接下页)

### 9.3.3.1 AC-Coupled Signal Path Considerations for Single-Ended Input to Differential Output Conversion

When the signal path can be AC-coupled, the DC biasing for the THS4532 family becomes a relatively simple task. In all designs, start by defining the output common-mode voltage. The AC-coupling issue can be separated for the input and output sides of an FDA design. The input can be AC-coupled and the output DC-coupled, or the output can be ac-coupled and the input dc-coupled, or they can both be AC-coupled.

One situation where the output might be DC-coupled (for an AC-coupled input), is when driving directly into an ADC where the  $V_{OCM}$  control voltage uses the ADC common-mode reference to directly bias the FDA output common-mode to the required ADC input common-mode. In any case, the design starts by setting the desired  $V_{OCM}$ .

When an AC-coupled path follows the output pins, the best linearity is achieved by operating  $V_{OCM}$  at midsupply. The  $V_{OCM}$  voltage must be within the linear range for the common-mode loop, as specified in the headroom specifications (approximately 0.91 V greater than the negative supply and 1.1 V less than the positive supply). If the output path is also ac-coupled, simply letting the  $V_{OCM}$  control pin float is usually preferred to get a midsupply default  $V_{OCM}$  bias with minimal elements. To limit noise, place a 0.1- $\mu$ F decoupling capacitor on the  $V_{OCM}$  pin to ground.

After  $V_{OCM}$  is defined, check the target output voltage swing to ensure that the  $V_{OCM}$  plus the positive and negative output swing on each side do not clip into the supplies. If the desired output differential swing is defined as  $V_{OPP}$ , divide by 4 to obtain the  $\pm V_P$  swing around  $V_{OCM}$  at each of the two output pins (each pin operates 180° out of phase with the other). Check that  $V_{OCM} \pm V_P$  does not exceed the absolute supply rails for this rail-to-rail output (RRO) device.

Going to the device input pins side, because both the source and balancing resistor on the nonsignal input side are DC-blocked (see [图 98](#)), no common-mode current flows from the output common-mode voltage, thus setting the input common-mode equal to the output common-mode voltage.

This input headroom also sets a limit for higher  $V_{OCM}$  voltages. Because the input  $V_{ICM}$  is the output  $V_{OCM}$  for ac-coupled sources, the 1.2-V minimum headroom for the input pins to the positive supply overrides the 1.1-V headroom limit for the output  $V_{OCM}$ . Also, the input signal moves this input  $V_{ICM}$  around the dc bias point, as described in the section [Resistor Design Equations for the Single-Ended to Differential Configuration of the FDA](#).

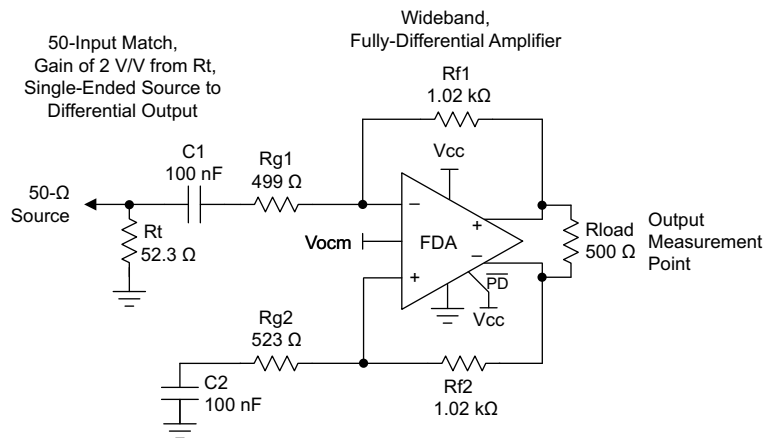

**图 98. AC-Coupled, Single-Ended Source to a Differential Gain of 2 V/V Test Circuit**

## Systems Examples (接下页)

### 9.3.3.2 DC-Coupled Input Signal Path Considerations for Single-Ended to Differential Conversion

The output considerations remain the same as for the AC-coupled design. Again, the input can be DC-coupled while the output is AC-coupled. A DC-coupled input with an AC-coupled output might have some advantages to move the input  $V_{ICM}$  down if the source is ground referenced. When the source is DC-coupled into the THS5432 family (see 图 99), both sides of the input circuit must be DC-coupled to retain differential balance. Normally, the nonsignal input side has an  $R_G$  element biased to whatever the source midrange is expected to be. Providing this midrange reference gives a balanced differential swing around  $V_{OCM}$  at the outputs.

Often,  $R_{G2}$  is simply grounded for DC-coupled, bipolar-input applications. This configuration gives a balanced differential output if the source is swinging around ground. If the source swings from ground to some positive voltage, grounding  $R_{G2}$  gives a unipolar output differential swing from both outputs at  $V_{OCM}$  (when the input is at ground) to one polarity of swing. Biasing  $R_{G2}$  to an expected midpoint for the input signal creates a differential output swing around  $V_{OCM}$ .

One significant consideration for a DC-coupled input is that  $V_{OCM}$  sets up a common-mode bias current from the output back through  $R_F$  and  $R_G$  to the source on both sides of the feedback. Without input balancing networks, the source must sink or source this DC current. After the input signal range and biasing on the other  $R_G$  element is set, check that the voltage divider from  $V_{OCM}$  to  $V_{IN}$  through  $R_F$  and  $R_G$  (and possibly  $R_S$ ) establishes an input  $V_{ICM}$  at the device input pins that is in range.

If the average source is at ground, the negative rail input stage for the THS5432 family is in range for applications using a single positive supply and a positive output  $V_{OCM}$  setting because this DC current lifts the average FDA input summing junctions up off of ground to a positive voltage (the average of the  $V+$  and  $V-$  input pin voltages on the FDA).



图 99. DC-Coupled, Single-Ended-to-Differential, Set for a Gain of 5 V/V

### 9.3.3.3 Resistor Design Equations for the Single-Ended to Differential Configuration of the FDA

The design equations for setting the resistors around an FDA to convert from a single-ended input signal to differential output can be approached from several directions. Here, several critical assumptions are made to simplify the results:

- The feedback resistors are selected first and set equal on the two sides.
- The DC and AC impedances from the summing junctions back to the signal source and ground (or a bias voltage on the nonsignal input side) are set equal to retain feedback divider balance on each side of the FDA.

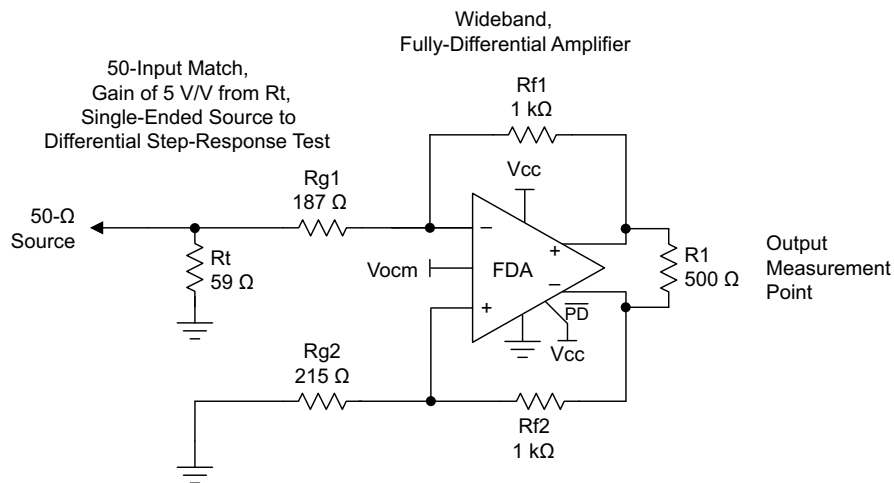
Both of these assumptions are typical for delivering the best dynamic range through the FDA signal path.

## Systems Examples (接下页)

After the feedback resistor values are chosen, the aim is to solve for the  $R_T$  (a termination resistor to ground on the signal input side),  $R_{G1}$  (the input gain resistor for the signal path), and  $R_{G2}$  (the matching gain resistor on the nonsignal input side); see 图 98 and 图 99. The same resistor solutions can be applied to either AC- or DC-coupled paths. Adding blocking capacitors in the input-signal chain is a simple option. Adding these blocking capacitors after the  $R_T$  element (as shown in 图 98) has the advantage of removing any DC currents in the feedback path from the output  $V_{OCM}$  to ground.

Earlier approaches to the solutions for  $R_T$  and  $R_{G1}$  (when the input must be matched to a source impedance,  $R_S$ ) follow an iterative approach. This complexity arises from the active input impedance at the  $R_{G1}$  input. When the FDA is used to convert a single-ended signal to differential, the common-mode input voltage at the FDA inputs must move with the input signal to generate the inverted output signal as a current in the  $R_{G2}$  element. A more recent solution is shown as 公式 8, where a quadratic in  $R_T$  can be solved for an exact value. This quadratic emerges from the simultaneous solution for a matched input impedance and target gain. The only inputs required are:

- The selected  $R_F$  value.
- The target voltage gain ( $A_V$ ) from the input of  $R_T$  to the differential output voltage.
- The desired input impedance at the junction of  $R_T$  and  $R_{G1}$  to match  $R_S$ .

Solving this quadratic for  $R_T$  starts the solution sequence, as shown in 公式 8:

$$R_T^2 - R_T \frac{2R_S(2R_F + \frac{R_S}{2}A_V^2)}{2R_F(2 + A_V) - R_S A_V(4 + A_V)} - \frac{2R_F R_S^2 A_V}{2R_F(2 + A_V) - R_S A_V(4 + A_V)} = 0 \quad (8)$$

Being a quadratic, there are limits to the range of solutions. Specifically, after  $R_F$  and  $R_S$  are chosen, there is physically a maximum gain beyond which 公式 8 starts to solve for negative  $R_T$  values (if input matching is a requirement). With  $R_F$  selected, use 公式 9 to verify that the maximum gain is greater than the desired gain.

$$A_{V(MAX)} = \left( \frac{R_F}{R_S} - 2 \right) \times \left[ 1 + \sqrt{1 + \frac{4 \frac{R_F}{R_S}}{\left( \frac{R_F}{R_S} - 2 \right)^2}} \right] \quad (9)$$

If the achievable  $A_{V(MAX)}$  is less than desired, increase the  $R_F$  value. After  $R_T$  is derived from 公式 8, the  $R_{G1}$  element is given by 公式 10:

$$R_{G1} = \frac{2 \frac{R_F}{A_V} - R_S}{1 + \frac{R_S}{R_T}} \quad (10)$$

Then, the simplest approach is to use a single  $R_{G2} = R_T \parallel R_S + R_{G1}$  on the nonsignal input side. Often, this approach is shown as the separate  $R_{G1}$  and  $R_S$  elements. Using these separate elements provides a better divider match on the two feedback paths, but a single  $R_{G2}$  is often acceptable. A direct solution for  $R_{G2}$  is given as 公式 11:

$$R_{G2} = \frac{2 \frac{R_F}{A_V}}{1 + \frac{R_S}{R_T}} \quad (11)$$

This design proceeds from a target input impedance matched to  $R_S$ , signal gain  $A_V$  from the matched input to the differential output voltage, and a selected  $R_F$  value. The nominal  $R_F$  value chosen for the THS4532 family characterization is 2 kΩ. As discussed previously, going lower improves noise and phase margin, but reduces the total output load impedance possibly degrading harmonic distortion. Going higher increases the output noise, and might reduce the loop-phase margin because of the feedback pole to the input capacitance, but reduces the total loading on the outputs.

## Systems Examples (接下页)

Using 公式 9 到 公式 11 来 sweep 目标增益从 1 到  $A_{V(\text{MAX})} < 10 \text{ V/V}$  给出 表 9, 其中显示了精确值用于  $R_T$ ,  $R_{G1}$ , 和  $R_{G2}$ , 其中一个  $50\text{-}\Omega$  源必须匹配而设置两个反馈电阻器到  $2 \text{ k}\Omega$ 。一个可能的解决方案对于 1% 标准值是显示的, 并且导致实际输入阻抗和增益与 % 误差到目标值也是显示在 表 9。

**表 9.  $R_f = 2 \text{ k}\Omega$ , Matched Input to  $50 \text{ }\Omega$ , Gain of 1 to 10-V/V Single-Ended to Differential<sup>(1)</sup>**

$A_v$	$R_t$ , EXACT ( $\Omega$ )	$R_t$ 1%	$R_{g1}$ , EXACT ( $\Omega$ )	$R_{g1}$ 1%	$R_{g2}$ , EXACT ( $\Omega$ )	$R_{g2}$ 1%	ACTUAL $Z_{IN}$	%ERR TO $R_s$	ACTUAL GAIN	%ERR TO $A_v$
1	51	51.1	1996.5	2000	2021.8	2000	50.1	0.3	0.998	-0.2
2	51.7	52.3	996.9	1000	1022.5	1020	50.5	1.0	1.994	-0.3
3	52.5	52.3	656.1	649	681.7	681	49.7	-0.5	3.032	1.1
4	53.2	53.6	491.5	487	517.4	523	50.2	0.4	4.035	0.9
5	54	53.6	388	392	413.9	412	49.6	-0.9	4.953	-0.9
6	54.7	54.9	322.7	324	348.9	348	49.9	-0.2	5.978	-0.4
7	55.5	54.9	272.9	274	299.1	301	49.1	-1.7	6.974	-0.4
8	56.3	56.2	238.1	237	264.6	267	49.3	-1.3	8.034	0.4
9	57.1	57.6	211.2	210	237.9	237	49.7	-0.6	9.044	0.5
10	57.9	57.6	187.4	187	214.1	215	48.9	-2.3	10.017	0.2

(1)  $R_F = 2 \text{ k}\Omega$ ,  $R_S = 50 \text{ }\Omega$ .

These equations and design flow apply to any FDA. Using the feedback resistor value as a starting point is particularly useful for current-feedback-based FDAs such as the [LMH6554](#), where the value of these feedback resistors determines the frequency response flatness. Similar tables can be built using the equations provided here for other source impedances,  $R_F$  values, and gain ranges.

The TINA model correctly shows this actively-set input impedance in the single-ended to differential configuration, and is a good tool to validate the gains, input impedances, response shapes, and noise issues.

### 9.3.4 Differential Input to Single-Ended Output Amplifier

Fully-differential amplifiers like the THS4532 are not recommended for differential to single-ended conversion. This application is best performed with an instrumentation amplifier or with a standard amplifier configured as a classic differential amplifier. See application section of the [OPA835](#) data sheet ([SLOS713](#)).

## 10 Power Supply Recommendations

The THS4532 is principally intended to operate with a nominal single-supply voltage of 3 V to 5 V. Supply-voltage tolerances are supported with the specified operating range of 2.5 V (10% low on a 3-V nominal supply) and 5.5 V (8% high on a 5-V nominal supply). Supply decoupling is required, as described in [Application and Implementation](#). Split (or bipolar) supplies can be used with the THS4532, as long as the total value across the device remains less than 5.5 V (absolute maximum).

Using a negative supply to deliver a true swing to ground output in driving SAR ADCs may be desired. While the THS4532 quotes a rail-to-rail output, linear operation requires approximately a 200-mV headroom to the supply rails. One easy option for extending the linear output swing to ground is to provide the small negative supply voltage required using the LM7705 fixed  $-230\text{-mV}$ , negative-supply generator. This low-cost, fixed negative-supply generator accepts the 3- to 5-V positive supply input used by the THS4532 and provides a  $-230\text{-mV}$  supply for the negative rail. Using the LM7705 provides an effective solution, as shown in the [Extending Rail-to-Rail Output Range for Fully Differential Amplifiers to Include True Zero Volts](#), TI Designs [TIDU187](#).

## 11 Layout

### 11.1 Layout Guidelines

The THS4532 EVM (SLOU356) should be used as a reference when designing the circuit board. TI recommends following the EVM layout of the external components near to the amplifier, ground plane construction, and power routing as closely as possible. General guidelines are:

1. Signal routing should be direct and as short as possible into and out of the amplifier.
2. The feedback path should be short and direct avoiding vias if possible.
3. Ground or power planes should be removed from directly under the amplifier's input and output pins.
4. A series output resistor is recommended to be placed as near to the output pin as possible. See [图 79](#) for recommended values given expected capacitive load of design.
5. A 2.2- $\mu$ F power supply decoupling capacitor should be placed within 2 inches of the device and can be shared with other amplifiers. For split supply, a capacitor is required for both supplies.
6. A 0.1- $\mu$ F power supply decoupling capacitor should be placed as near to the power supply pins as possible. Preferably within 0.1 inch. For split supply, a capacitor is required for both supplies.
7. The  $\overline{\text{PD}}$  pin uses TTL logic levels referenced to the negative supply voltage ( $V_{\text{S}}$ ). When not used it should be tied to the positive supply to enable the amplifier. When used, it must be actively driven high or low and should not be left in an indeterminate logic state. A bypass capacitor is not required, but can be used for robustness in noisy environments.

## 11.2 Layout Example

图 100 through 图 103 illustrate the PCB layers of the EVM.



图 100. THS4532 EVM Top Layer 1

**Layout Example (接下页)**

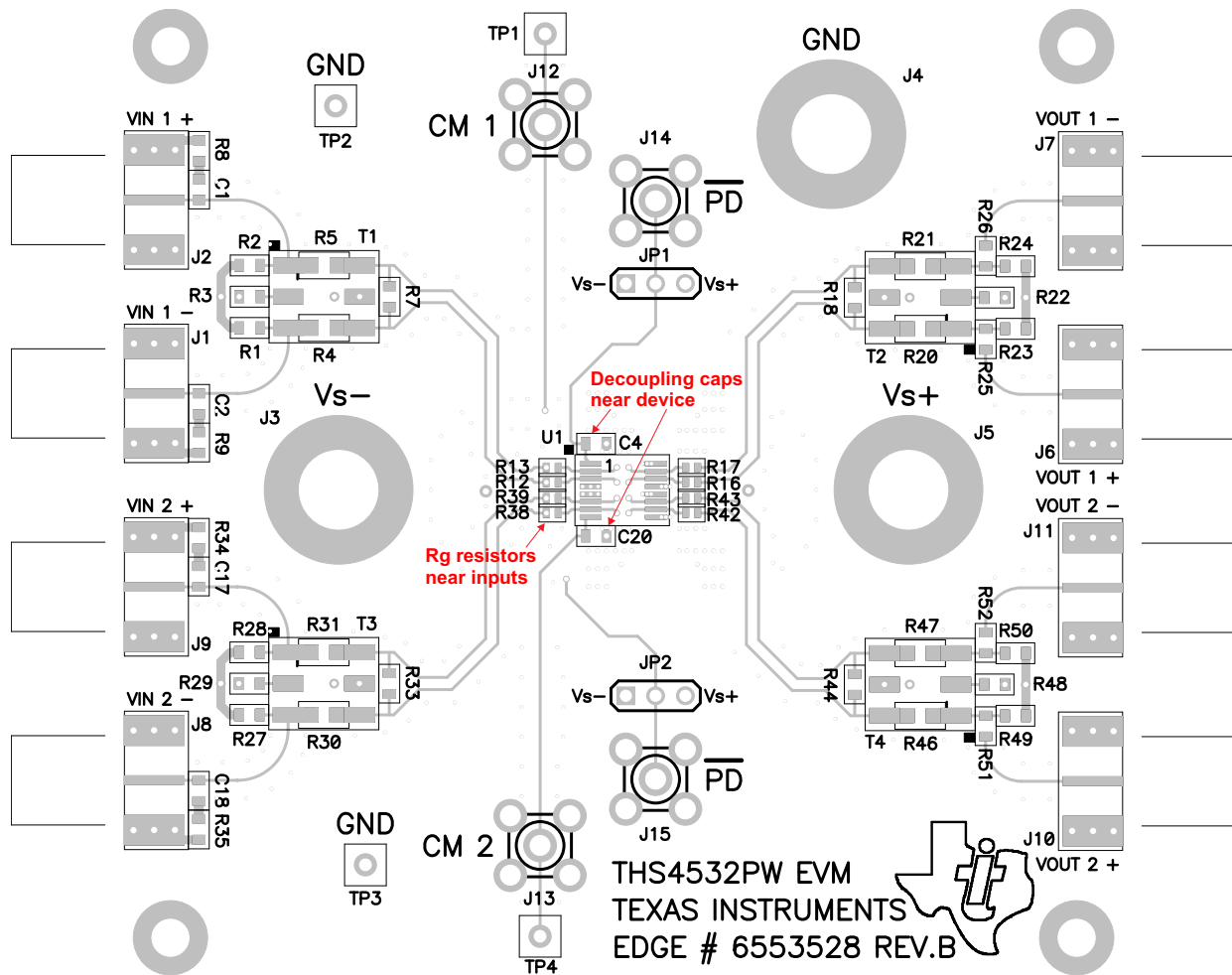
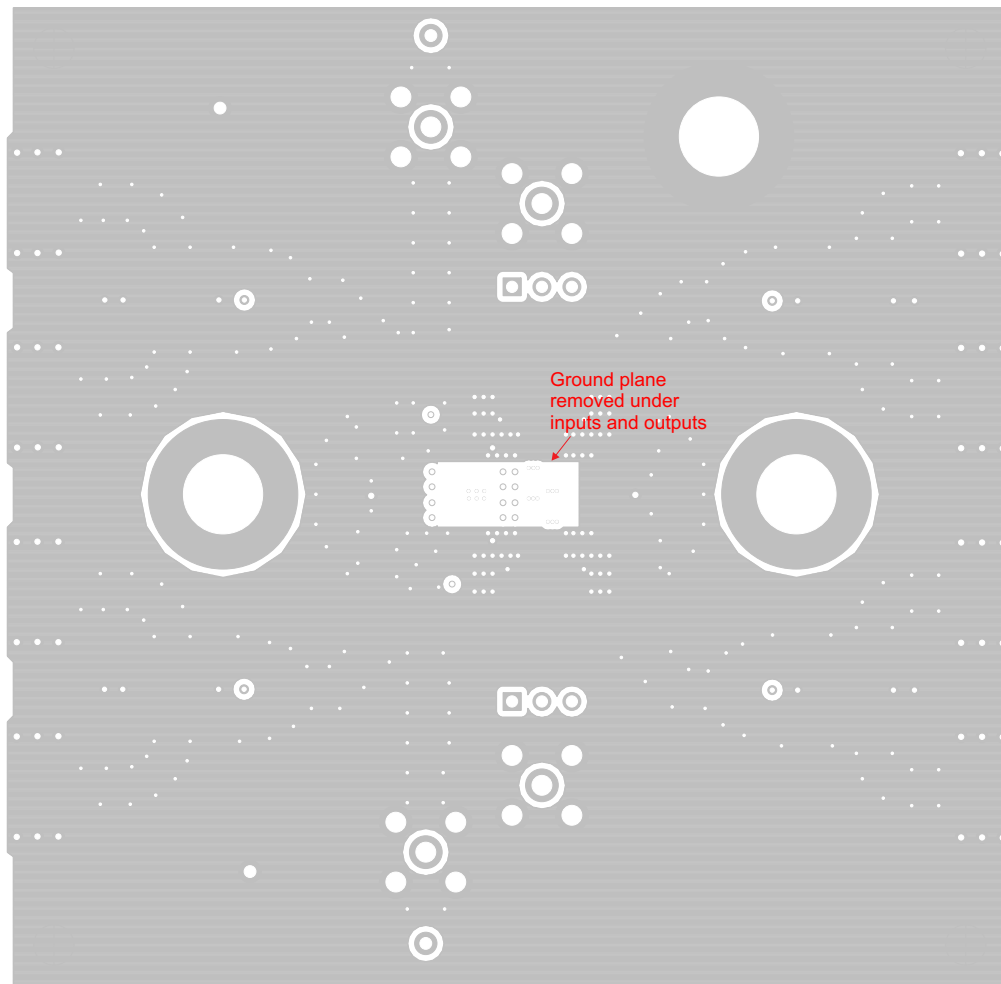

**图 101. THS4532 EVM Ground Layer 2**

Layout Example (接下页)



图 102. THS4532 EVM Ground Layer 3

Layout Example (接下页)

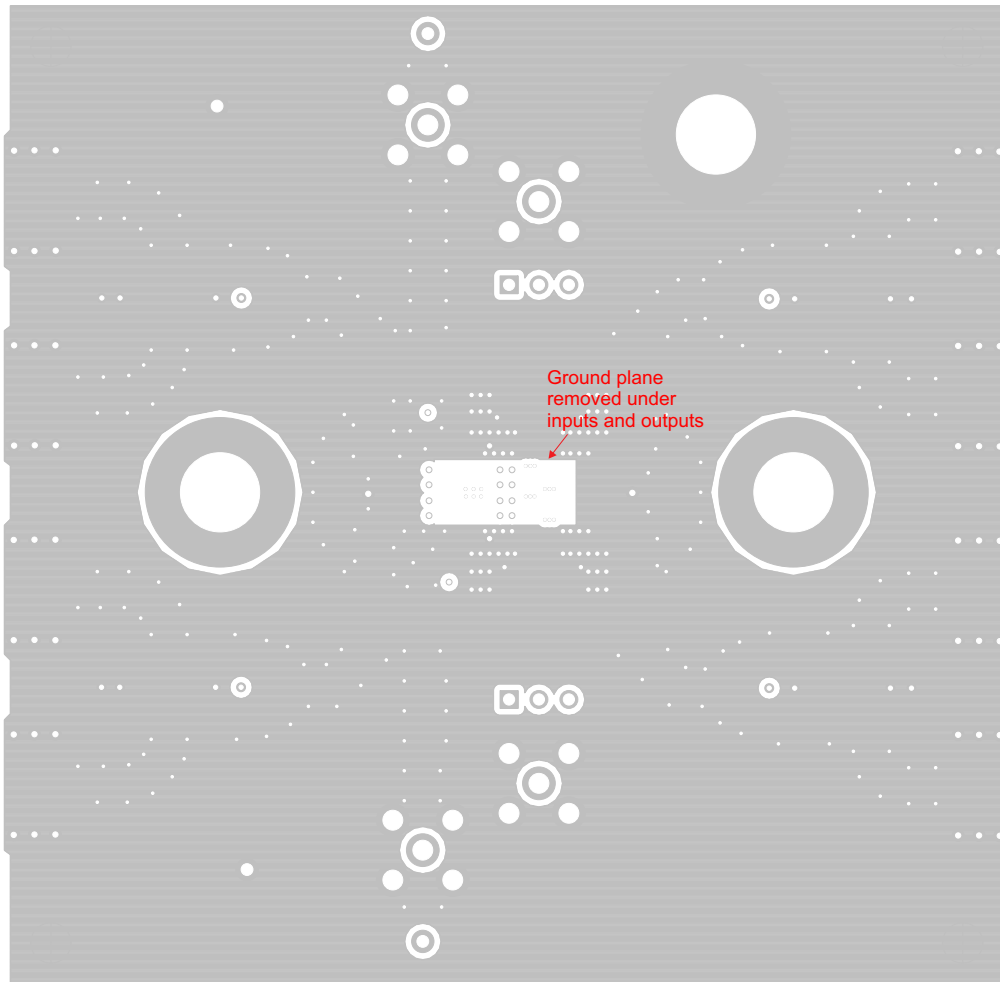

图 103. THS4532 EVM Bottom Layer 4

## 12 器件和文档支持

### 12.1 文档支持

《16 位高速低功耗采样模数转换器》， [SBAS123](#)

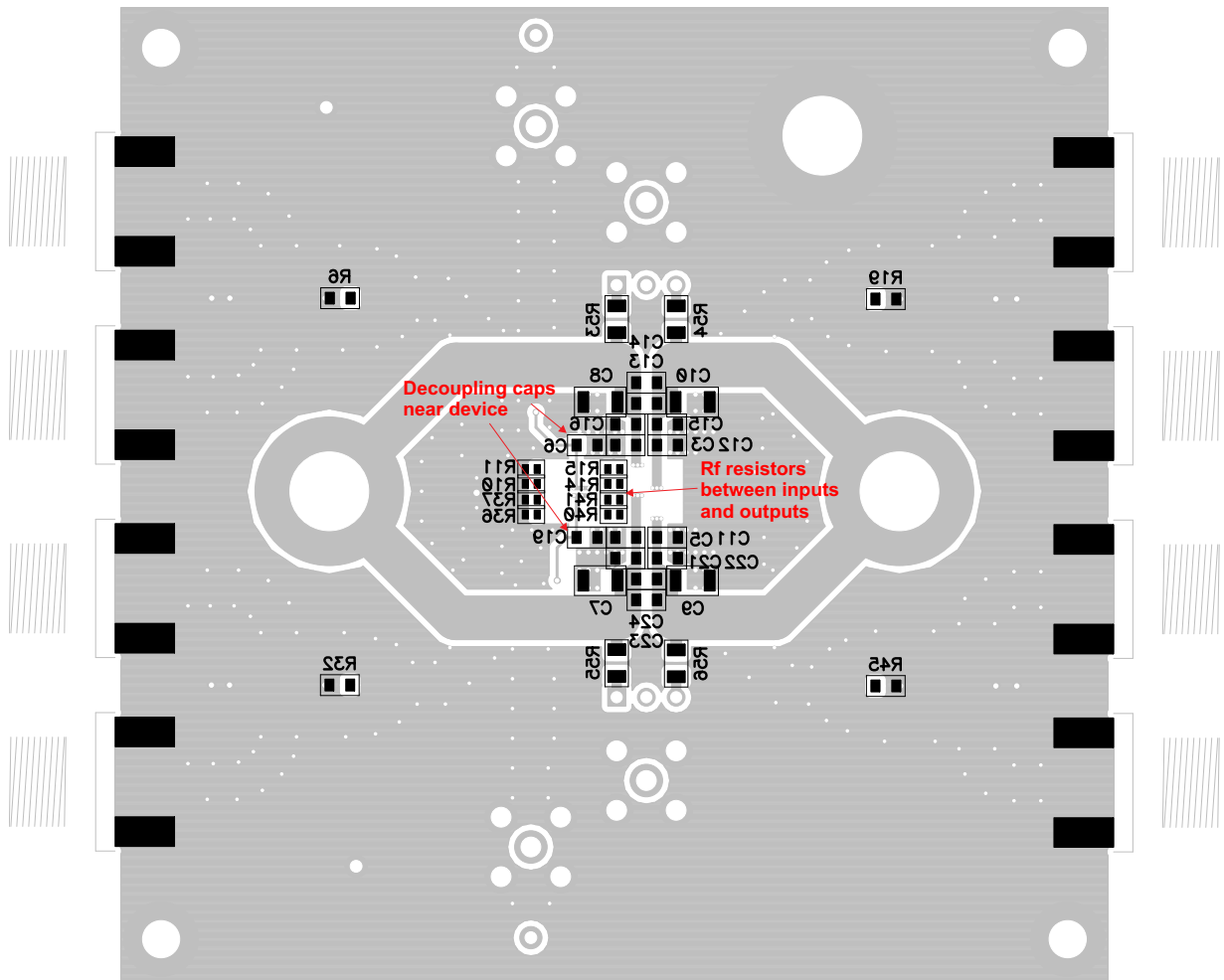
PCM4204: 《高性能 24 位、216kHz 采样四通道音频 A/D 转换器》， [SBAS327](#)

《14位、2MSPS、双通道、差分/单端、超低功耗 ADC》， [SBAS539](#)

《全差分放大器》， [SLOA054](#)

《超低功耗、轨到轨输出、负电源轨输入、VFB 运算放大器》， [SLOS713](#)

《THS4532 EVM 评估模块》， [SLOU358](#)

### 12.2 社区资源

The following links connect to TI community resources. Linked contents are provided "AS IS" by the respective contributors. They do not constitute TI specifications and do not necessarily reflect TI's views; see TI's [Terms of Use](#).

**TI E2E™ Online Community** *TI's Engineer-to-Engineer (E2E) Community*. Created to foster collaboration among engineers. At [e2e.ti.com](http://e2e.ti.com), you can ask questions, share knowledge, explore ideas and help solve problems with fellow engineers.

**Design Support** *TI's Design Support* Quickly find helpful E2E forums along with design support tools and contact information for technical support.

### 12.3 商标

E2E is a trademark of Texas Instruments.

All other trademarks are the property of their respective owners.

### 12.4 静电放电警告



这些装置包含有限的内置 ESD 保护。存储或装卸时，应将导线一起截短或将装置放置于导电泡棉中，以防止 MOS 门极遭受静电损伤。

### 12.5 Glossary

[SLYZ022](#) — *TI Glossary*.

This glossary lists and explains terms, acronyms, and definitions.

## 13 机械、封装和可订购信息

以下页中包括机械、封装和可订购信息。 这些信息是针对指定器件可提供的最新数据。 这些数据会在无通知且不对本文档进行修订的情况下发生改变。 欲获得该数据表的浏览器版本，请查阅左侧的导航栏。

**PACKAGING INFORMATION**

Orderable Device	Status (1)	Package Type	Package Drawing	Pins	Package Qty	Eco Plan (2)	Lead finish/ Ball material (6)	MSL Peak Temp (3)	Op Temp (°C)	Device Marking (4/5)	Samples
THS4532IPW	ACTIVE	TSSOP	PW	16	90	RoHS & Green	NIPDAU	Level-2-260C-1 YEAR	-40 to 125	THS4532	<a href="#">Samples</a>
THS4532IPWR	ACTIVE	TSSOP	PW	16	2000	RoHS & Green	NIPDAU	Level-2-260C-1 YEAR	-40 to 125	THS4532	<a href="#">Samples</a>

(1) The marketing status values are defined as follows:

**ACTIVE:** Product device recommended for new designs.

**LIFEBUY:** TI has announced that the device will be discontinued, and a lifetime-buy period is in effect.

**NRND:** Not recommended for new designs. Device is in production to support existing customers, but TI does not recommend using this part in a new design.

**PREVIEW:** Device has been announced but is not in production. Samples may or may not be available.

**OBsolete:** TI has discontinued the production of the device.

(2) **RoHS:** TI defines "RoHS" to mean semiconductor products that are compliant with the current EU RoHS requirements for all 10 RoHS substances, including the requirement that RoHS substance do not exceed 0.1% by weight in homogeneous materials. Where designed to be soldered at high temperatures, "RoHS" products are suitable for use in specified lead-free processes. TI may reference these types of products as "Pb-Free".

**RoHS Exempt:** TI defines "RoHS Exempt" to mean products that contain lead but are compliant with EU RoHS pursuant to a specific EU RoHS exemption.

**Green:** TI defines "Green" to mean the content of Chlorine (Cl) and Bromine (Br) based flame retardants meet JS709B low halogen requirements of <=1000ppm threshold. Antimony trioxide based flame retardants must also meet the <=1000ppm threshold requirement.

(3) MSL, Peak Temp. - The Moisture Sensitivity Level rating according to the JEDEC industry standard classifications, and peak solder temperature.

(4) There may be additional marking, which relates to the logo, the lot trace code information, or the environmental category on the device.

(5) Multiple Device Markings will be inside parentheses. Only one Device Marking contained in parentheses and separated by a "~" will appear on a device. If a line is indented then it is a continuation of the previous line and the two combined represent the entire Device Marking for that device.

(6) Lead finish/Ball material - Orderable Devices may have multiple material finish options. Finish options are separated by a vertical ruled line. Lead finish/Ball material values may wrap to two lines if the finish value exceeds the maximum column width.

**Important Information and Disclaimer:**The information provided on this page represents TI's knowledge and belief as of the date that it is provided. TI bases its knowledge and belief on information provided by third parties, and makes no representation or warranty as to the accuracy of such information. Efforts are underway to better integrate information from third parties. TI has taken and continues to take reasonable steps to provide representative and accurate information but may not have conducted destructive testing or chemical analysis on incoming materials and chemicals. TI and TI suppliers consider certain information to be proprietary, and thus CAS numbers and other limited information may not be available for release.

In no event shall TI's liability arising out of such information exceed the total purchase price of the TI part(s) at issue in this document sold by TI to Customer on an annual basis.

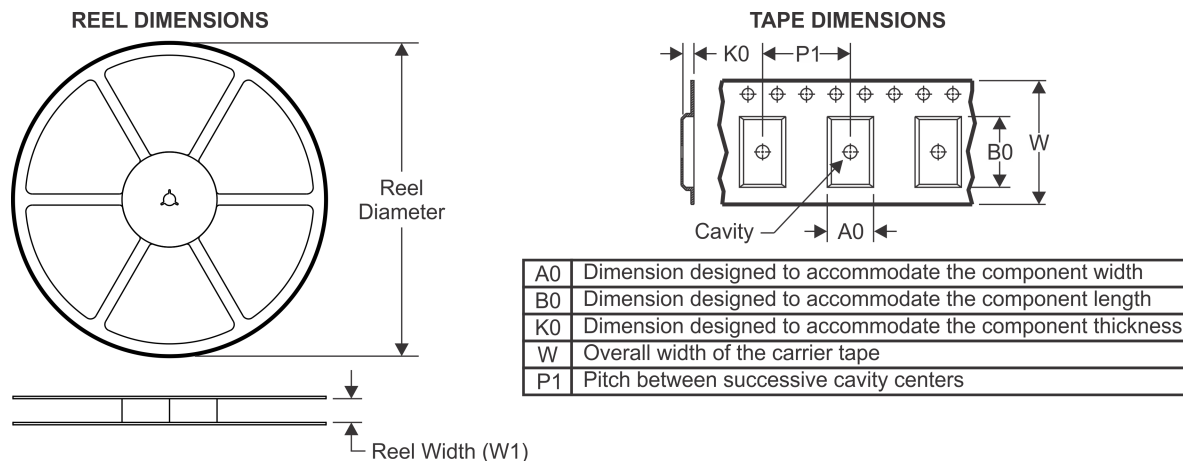
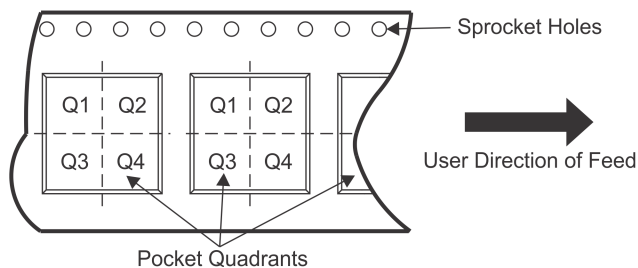

**TAPE AND REEL INFORMATION**

**QUADRANT ASSIGNMENTS FOR PIN 1 ORIENTATION IN TAPE**

\*All dimensions are nominal

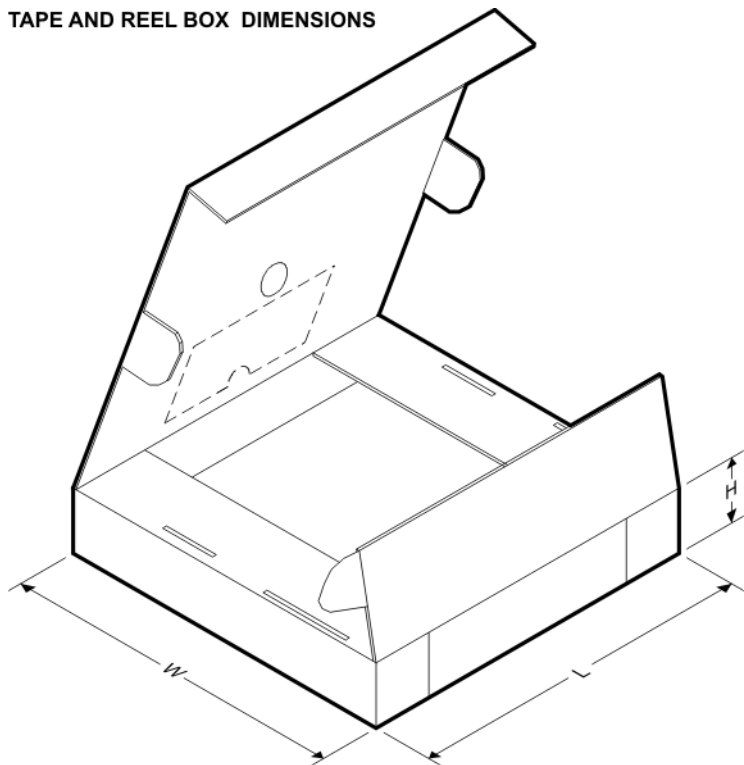
Device	Package Type	Package Drawing	Pins	SPQ	Reel Diameter (mm)	Reel Width W1 (mm)	A0 (mm)	B0 (mm)	K0 (mm)	P1 (mm)	W (mm)	Pin1 Quadrant
THS4532IPWR	TSSOP	PW	16	2000	330.0	12.4	6.9	5.6	1.6	8.0	12.0	Q1

**TAPE AND REEL BOX DIMENSIONS**

\*All dimensions are nominal

Device	Package Type	Package Drawing	Pins	SPQ	Length (mm)	Width (mm)	Height (mm)
THS4532IPWR	TSSOP	PW	16	2000	853.0	449.0	35.0

**TUBE**

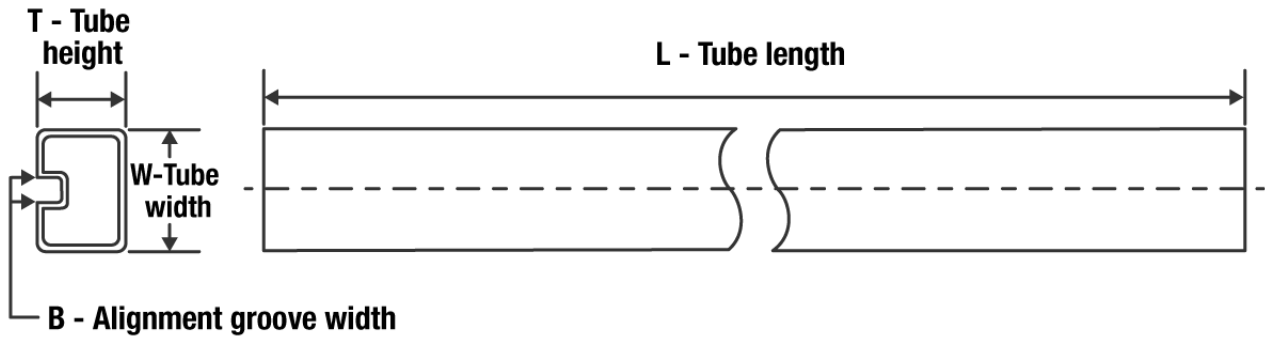

\*All dimensions are nominal

Device	Package Name	Package Type	Pins	SPQ	L (mm)	W (mm)	T (μm)	B (mm)
THS4532IPW	PW	TSSOP	16	90	530	10.2	3600	3.5

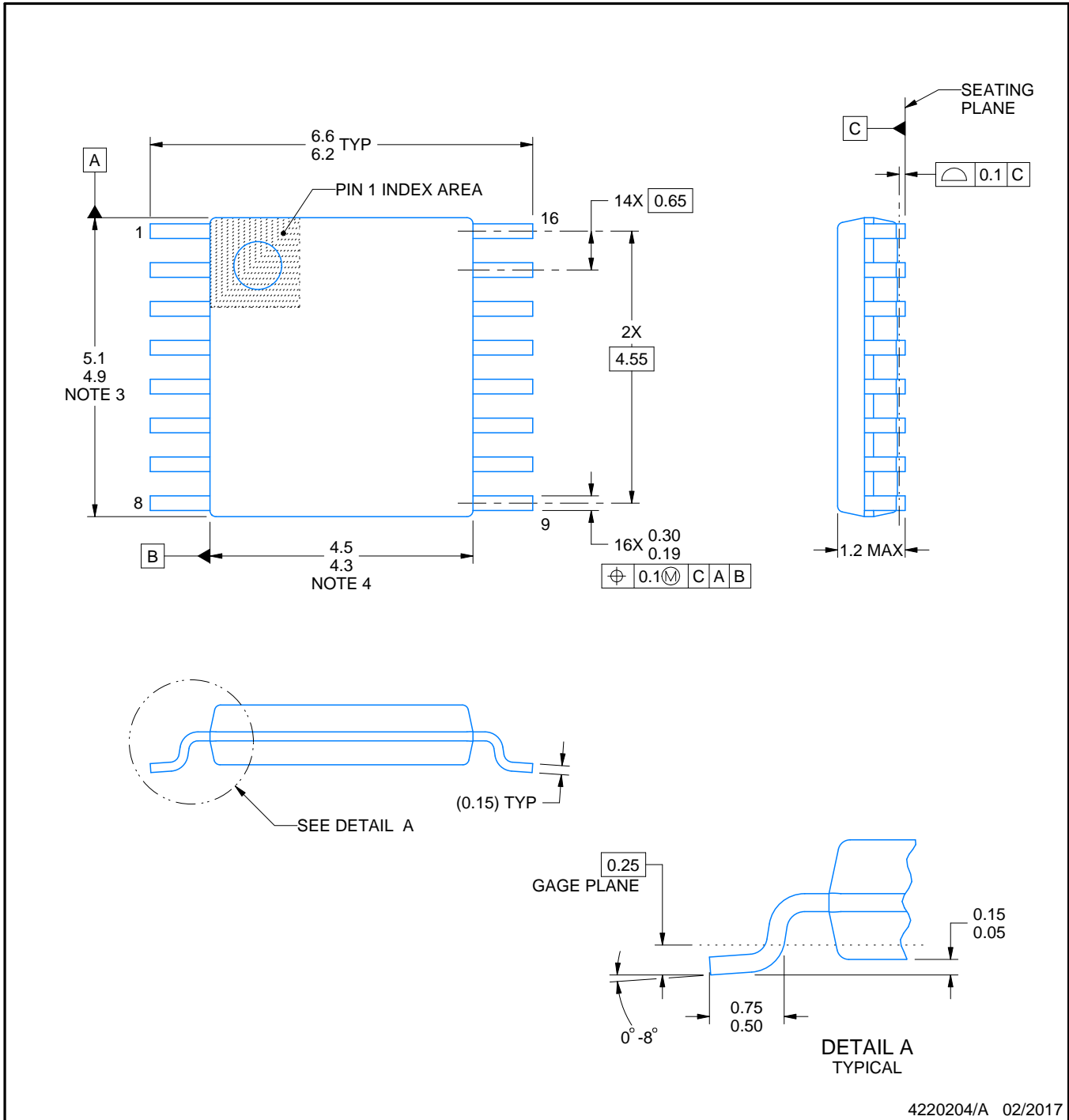
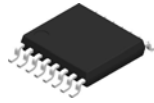

**NOTES:**

1. All linear dimensions are in millimeters. Any dimensions in parenthesis are for reference only. Dimensioning and tolerancing per ASME Y14.5M.
2. This drawing is subject to change without notice.
3. This dimension does not include mold flash, protrusions, or gate burrs. Mold flash, protrusions, or gate burrs shall not exceed 0.15 mm per side.
4. This dimension does not include interlead flash. Interlead flash shall not exceed 0.25 mm per side.
5. Reference JEDEC registration MO-153.

# EXAMPLE BOARD LAYOUT

PW0016A

TSSOP - 1.2 mm max height

SMALL OUTLINE PACKAGE

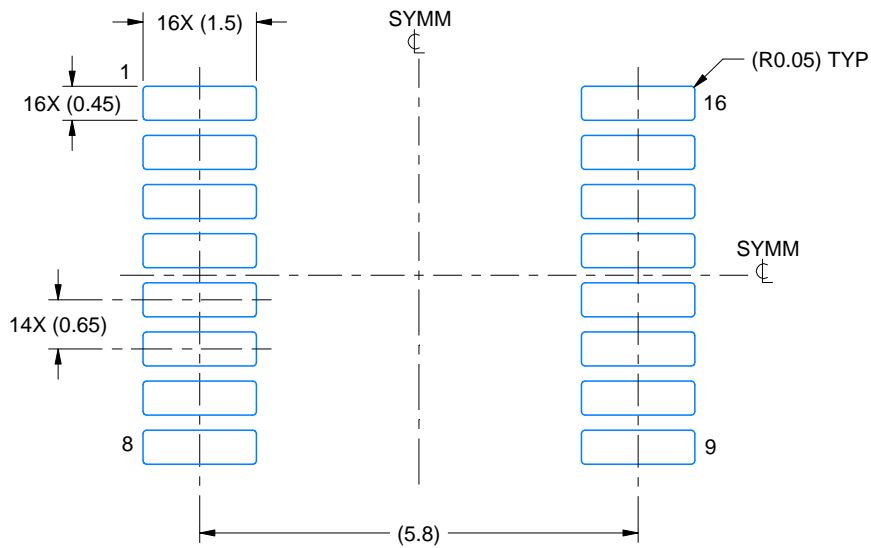

LAND PATTERN EXAMPLE  
EXPOSED METAL SHOWN  
SCALE: 10X

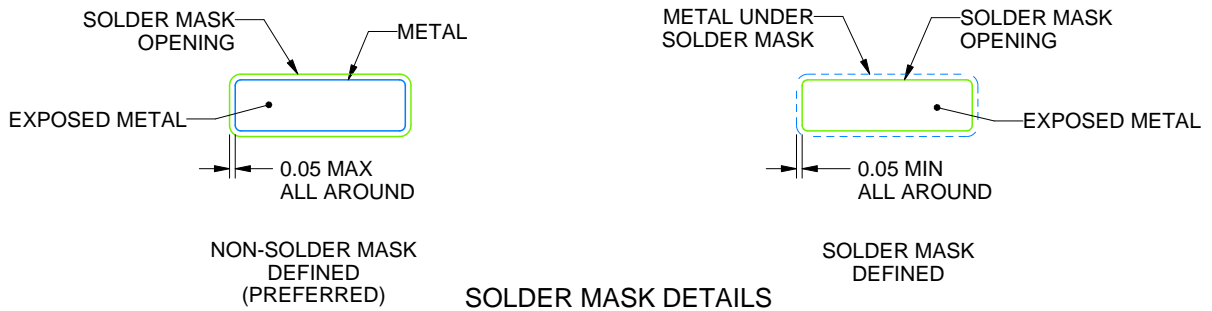

SOLDER MASK DETAILS

4220204/A 02/2017

NOTES: (continued)

- 6. Publication IPC-7351 may have alternate designs.
- 7. Solder mask tolerances between and around signal pads can vary based on board fabrication site.

# EXAMPLE STENCIL DESIGN

PW0016A

TSSOP - 1.2 mm max height

SMALL OUTLINE PACKAGE

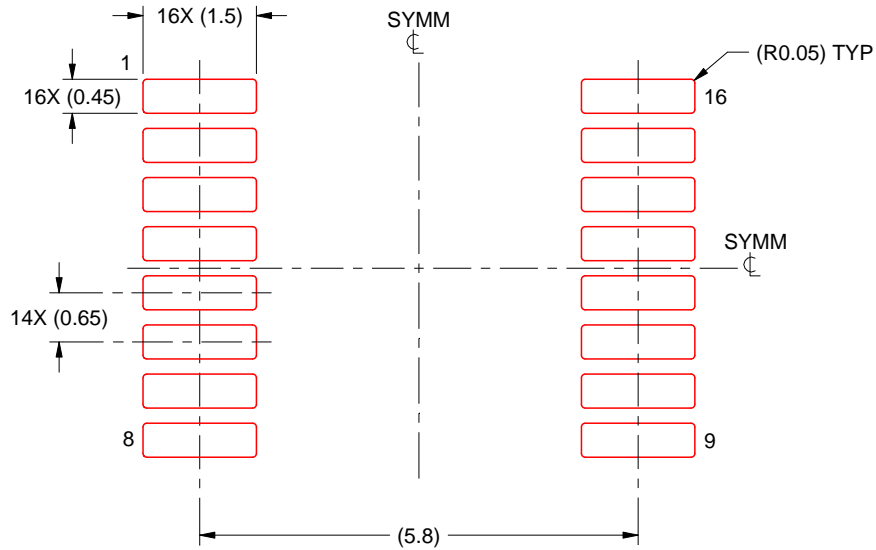

SOLDER PASTE EXAMPLE  
BASED ON 0.125 mm THICK STENCIL  
SCALE: 10X

4220204/A 02/2017

NOTES: (continued)

8. Laser cutting apertures with trapezoidal walls and rounded corners may offer better paste release. IPC-7525 may have alternate design recommendations.
9. Board assembly site may have different recommendations for stencil design.

## 重要声明和免责声明

TI“按原样”提供技术和可靠性数据（包括数据表）、设计资源（包括参考设计）、应用或其他设计建议、网络工具、安全信息和其他资源，不保证没有瑕疵且不做任何明示或暗示的担保，包括但不限于对适销性、某特定用途方面的适用性或不侵犯任何第三方知识产权的暗示担保。

这些资源可供使用 TI 产品进行设计的熟练开发人员使用。您将自行承担以下全部责任：(1) 针对您的应用选择合适的 TI 产品，(2) 设计、验证并测试您的应用，(3) 确保您的应用满足相应标准以及任何其他功能安全、信息安全、监管或其他要求。

这些资源如有变更，恕不另行通知。TI 授权您仅可将这些资源用于研发本资源所述的 TI 产品的应用。严禁对这些资源进行其他复制或展示。您无权使用任何其他 TI 知识产权或任何第三方知识产权。您应全额赔偿因在这些资源的使用中对 TI 及其代表造成的任何索赔、损害、成本、损失和债务，TI 对此概不负责。

TI 提供的产品受 [TI 的销售条款](#) 或 [ti.com](#) 上其他适用条款/TI 产品随附的其他适用条款的约束。TI 提供这些资源并不会扩展或以其他方式更改 TI 针对 TI 产品发布的适用的担保或担保免责声明。

TI 反对并拒绝您可能提出的任何其他或不同的条款。

邮寄地址：Texas Instruments, Post Office Box 655303, Dallas, Texas 75265

Copyright © 2022，德州仪器 (TI) 公司