

TPS6526x 4.5V 至 18V 输入电压、3A/2A/2A 输出电流、三路同步降压转换器

1 特性

- 工作输入电源电压范围 (4.5V 至 18V)
- 反馈基准电压 $0.6V \pm 1\%$
- 最大持续输出电流 3A/2A/2A
- 250kHz 至 2MHz 的可调时钟频率
- 针对每个降压转换器的专用使能和软启动引脚
- 自动加电/断电序列
- 轻载条件下的脉冲跳跃模式 (PSM) (仅限 TPS65261)
- 输出电压电源正常指示器
- 输入电压电源故障指示器
- 热过载保护

2 应用

- 数字电视 (DTV)
- 机顶盒
- 家庭网关和访问点网络
- 无线路由器
- 安全监控
- 销售点 (POS) 机器

3 说明

TPS65261, TPS65261-1 是一款具有 3A/2A/2A 输出电流的单片三路同步步降 (降压) 转换器。4.5V 至 18V 的宽输入电源电压范围包括大多数运行自 5V, 9V, 12V 或者 15V 电源总线的中间总线电压。这个具有恒定频率峰值电流模式控制的转换器被设计用来简化它的应用, 与此同时, 能够使设计人员根据目标应用来优化系统。可使用一个外部电阻器在 250kHz 至 2MHz 之间调整此转换器的开关频率。Buck1 和 Buck 2, 3 之间的 180° 异相运行 (Buck2 和 3 同相运行) 最大限度地减少了对输入滤波器的要求。

在将 MODE 引脚接至 V7V 并且配置 EN1/2/3 引脚时, TPS65261, TPS65261-1 特有一个自动上电时序。此器件还特有一个开漏 RESET 信号来监视断电。

轻负载时, TPS65261 自动运行在脉冲跳跃模式 (PSM), 而 TPS65261-1 运行在强制持续电流模式 (FCC)。PSM 模式通过减少轻负载时的开关损耗来提供高效率, 而 FCC 模式降低噪声灵敏性和射频 (RF) 干扰。

此器件特有过压保护、过流和短路保护以及过热保护。电源正常引脚在任何输出电压在稳压范围之外时被置为有效。

器件信息 (1)

器件型号	封装	封装尺寸 (标称值)
TPS65261, TPS65261-1	VQFN (32)	5.00mm x 5.00mm

(1) 如需了解所有可用封装, 请见数据表末尾的可订购产品附录。

4 典型应用

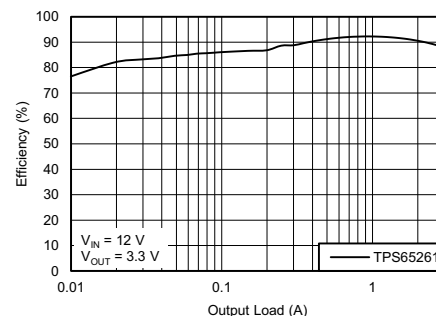
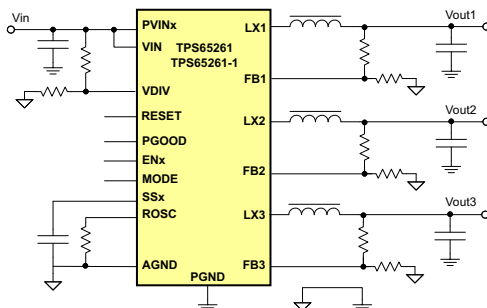

目录

1	特性	1	8.3	Feature Description	13
2	应用	1	8.4	Device Functional Modes	22
3	说明	1	9	Application and Implementation	24
4	典型应用	1	9.1	Application Information	24
5	修订历史记录	2	9.2	Typical Application	24
6	Pin Configuration and Functions	3	10	Power Supply Recommendations	34
7	Specifications	4	11	Layout	34
7.1	Absolute Maximum Ratings	4	11.1	Layout Guidelines	34
7.2	Handling Ratings	5	11.2	Layout Example	35
7.3	Recommended Operating Conditions	5	12	器件和文档支持	36
7.4	Thermal Information	5	12.1	文档支持	36
7.5	Electrical Characteristics	6	12.2	相关链接	36
7.6	Typical Characteristics	8	12.3	商标	36
8	Detailed Description	12	12.4	静电放电警告	36
8.1	Overview	12	12.5	术语表	36
8.2	Functional Block Diagram	13	13	机械封装和可订购信息	36

5 修订历史记录

Changes from Revision A (December 2013) to Revision B

Page

•	Changed Figure 70	35
---	---	----

6 Pin Configuration and Functions

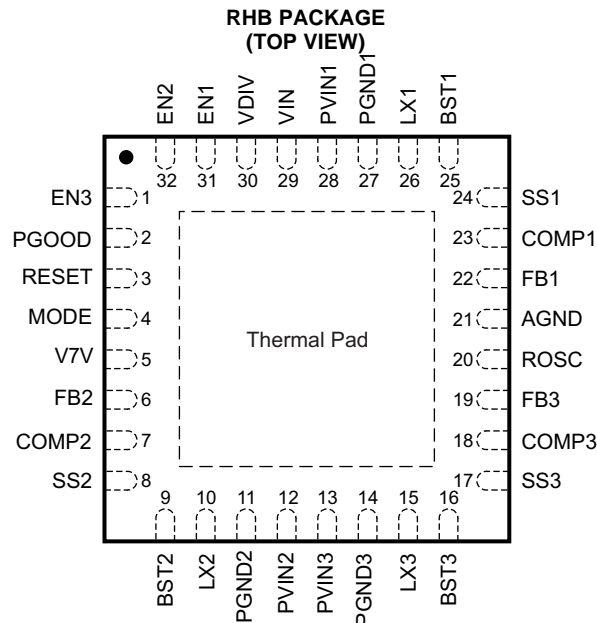

(There is no electric signal down bonded to thermal pad inside IC.
Exposed thermal pad must be soldered to PCB for optimal thermal performance.)

Pin Functions

PIN		DESCRIPTION
NO.	NAME	
1	EN3	Enable for buck3. Float to enable. Can use this pin to adjust the input under-voltage lockout of buck3 with a resistor divider.
2	PGOOD	An open drain output, asserts low if output voltage of any buck beyond regulation range due to thermal shutdown, over-current, under-voltage or ENx shut down.
3	RESET	Open drain power failure output signal.
4	MODE	When high, an automatic power-up/power-down sequence is provided according to states of EN1, EN2 and EN3 pins.
5	V7V	Internal LDO for gate driver and internal controller. Connect a 1 μ F capacitor from the pin to power ground
6	FB2	Feedback Kelvin sensing pin for buck2 output voltage. Connect this pin to buck2 resistor divider.
7	COMP2	Error amplifier output and Loop compensation pin for buck2. Connect a series resistor and capacitor to compensate the control loop of buck2 with peak current PWM mode.
8	SS2	Soft-start and tracking input for buck2. An internal 5 μ A pull-up current source is connected to this pin. The soft-start time can be programmed by connecting a capacitor between this pin and ground.
9	BST2	Boot strapped supply to the high side floating gate driver in buck2. Connect a capacitor (recommend 47nF) from BST2 pin to LX2 pin.
10	LX2	Switching node connection to the inductor and bootstrap capacitor for buck2. The voltage swing at this pin is from a diode voltage below the ground up to PVIN2 voltage.
11	PGND2	Power ground connection of buck2. Connect PGND2 pin as close as practical to the (–) terminal of VIN2 input ceramic capacitor.
12	PVIN2	Input power supply for buck2. Connect PVIN2 pin as close as practical to the (+) terminal of an input ceramic capacitor (suggest 10 μ F).
13	PVIN3	Input power supply for buck3. Connect PVIN3 pin as close as practical to the (+) terminal of an input ceramic capacitor (suggest 10 μ F).
14	PGND3	Power ground connection of buck3. Connect PGND3 pin as close as practical to the (–) terminal of VIN3 input ceramic capacitor.
15	LX3	Switching node connection to the inductor and bootstrap capacitor for buck3. The voltage swing at this pin is from a diode voltage below the ground up to PVIN3 voltage.

Pin Functions (continued)

PIN		DESCRIPTION
NO.	NAME	
16	BST3	Boot strapped supply to the high side floating gate driver in buck3. Connect a capacitor (recommend 47nF) from BST3 pin to LX3 pin.
17	SS3	Soft-start and tracking input for buck3. An internal 5µA pull-up current source is connected to this pin. The soft-start time can be programmed by connecting a capacitor between this pin and ground.
18	COMP3	Error amplifier output and Loop compensation pin for buck3. Connect a series resistor and capacitor to compensate the control loop of buck3 with peak current PWM mode.
19	FB3	Feedback Kelvin sensing pin for buck3 output voltage. Connect this pin to buck3 resistor divider.
20	ROSC	Oscillator frequency programmable pin. Connect an external resistor to set the switching frequency.
21	AGND	Analog ground common to buck controllers and other analog circuits. It must be routed separately from high current power grounds to the (–) terminal of bypass capacitor of input voltage VIN.
22	FB1	Feedback Kelvin sensing pin for buck1 output voltage. Connect this pin to buck1 resistor divider.
23	COMP1	Error amplifier output and Loop compensation pin for buck1. Connect a series resistor and capacitor to compensate the control loop of buck1 with peak current PWM mode.
24	SS1	Soft-start and tracking input for buck1. An internal 5µA pull-up current source is connected to this pin. The soft-start time can be programmed by connecting a capacitor between this pin and ground.
25	BST1	Boot strapped supply to the high side floating gate driver in buck1. Connect a capacitor (recommend 47nF) from BST1 pin to LX1 pin.
26	LX1	Switching node connection to the inductor and bootstrap capacitor for buck1. The voltage swing at this pin is from a diode voltage below the ground up to PVIN1 voltage.
27	PGND1	Power ground connection of Buck1. Connect PGND1 pin as close as practical to the (–) terminal of VIN1 input ceramic capacitor.
28	PVIN1	Input power supply for buck1. Connect PVIN1 pin as close as practical to the (+) terminal of an input ceramic capacitor (suggest 10µF).
29	VIN	Buck controller power supply.
30	VDIV	Input voltage threshold for power failure detection of input voltage.
31	EN1	Enable for buck1. Float to enable. Can use this pin to adjust the input under-voltage lockout of buck1 with a resistor divider.
32	EN2	Enable for buck2. Float to enable. Can use this pin to adjust the input under-voltage lockout of buck2 with a resistor divider.
	PAD	There is no electric signal down bonded to thermal pad inside IC. Exposed thermal pad must be soldered to PCB for optimal thermal performance.

7 Specifications

7.1 Absolute Maximum Ratings

 over operating free-air temperature range (unless otherwise noted) ⁽¹⁾

	MIN	MAX	UNIT
PVIN1, PVIN2, PVIN3, VIN	–0.3	20	V
LX1, LX2, LX3 (Maximum withstand voltage transient < 20 ns)	–1.0	20	V
BST1, BST2, BST3 referenced to LX1, LX2, LX3 pins respectively	–0.3	7	V
EN1, EN2, EN3, PGOOD, V7V, MODE, RESET, VDIV	–0.3	7	V
FB1, FB2, FB3, COMP1, COMP2, COMP3, SS1, SS2, SS3, ROSC	–0.3	3.6	V
AGND, PGND1, PGND2, PGND3	–0.3	0.3	V
Operating junction temperature, T _j	–40	125	°C

- (1) Stresses beyond those listed under *Absolute Maximum Ratings* may cause permanent damage to the device. These are stress ratings only, which do not imply functional operation of the device at these or any other conditions beyond those indicated under *Recommended Operating Conditions*. Exposure to absolute-maximum-rated conditions for extended periods may affect device reliability.

7.2 Handling Ratings

		MIN	MAX	UNIT	
T_{stg}	Storage temperature range	-55	150	°C	
$V_{(ESD)}$	Electrostatic discharge	Human body model (HBM), per ANSI/ESDA/JEDEC JS-001, all pins ⁽¹⁾	-2000	2000	V
		Charged device model (CDM), per JEDEC specification JESD22-C101, all pins ⁽²⁾	-500	500	

(1) JEDEC document JEP155 states that 500-V HBM allows safe manufacturing with a standard ESD control process.

(2) JEDEC document JEP157 states that 250-V CDM allows safe manufacturing with a standard ESD control process.

7.3 Recommended Operating Conditions

over operating free-air temperature range (unless otherwise noted)

		MIN	NOM	MAX	UNIT
	PVIN1, PVIN2, PVIN3, VIN	4.5		18	V
	LX1, LX2, LX3 (Maximum withstand voltage transient < 20 ns)	-0.8		18	V
	BST1, BST2, BST3 referenced to LX1, LX2, LX3 pins respectively	-0.1		6.8	V
	EN1, EN2, EN3, PGOOD, V7V, MODE, RESET, VDIV	-0.1		6.3	V
	FB1, FB2, FB3, COMP1, COMP2, COMP3, SS1, SS2, SS3, ROSC	-0.1		3	V
T_A	Operating junction temperature	-40		85	°C
T_J	Operating junction temperature	-40		125	°C

7.4 Thermal Information

THERMAL METRIC ⁽¹⁾		TPS65261	UNIT
		RHB (32 PINS)	
$R_{\theta JA}$	Junction-to-ambient thermal resistance	31.6	°C/W
$R_{\theta JC(top)}$	Junction-to-case (top) thermal resistance	23.4	
$R_{\theta JB}$	Junction-to-board thermal resistance	6.1	
ψ_{JT}	Junction-to-top characterization parameter	0.2	
ψ_{JB}	Junction-to-board characterization parameter	6.1	
$R_{\theta JC(bot)}$	Junction-to-case (bottom) thermal resistance	0.9	

(1) For more information about traditional and new thermal metrics, see the *IC Package Thermal Metrics* application report, [SPRA953](#).

7.5 Electrical Characteristics

 $T_A = 25^\circ\text{C}$, $V_{IN} = 12\text{ V}$, $f_{SW} = 600\text{ kHz}$ (unless otherwise noted)

PARAMETER		TEST CONDITIONS	MIN	TYP	MAX	UNIT
INPUT SUPPLY VOLTAGE						
V _{IN}	Input voltage range		4.5		18	V
UVLO	VIN under-voltage lockout	VIN rising	4	4.25	4.5	V
		VIN falling	3.5	3.75	4	V
		Hysteresis		500		mV
I _{DDSDN}	Shutdown supply current	EN1=EN2=EN3=MODE=0V		9.2		μA
I _{DDQ_NSW}	Input quiescent current without buck1/2/3 switching	EN1=EN2=EN3=5V, FB1=FB2=FB3=0.8V		605		μA
I _{DDQ_NSW1}		EN1=5V, EN2=EN3=0V, FB1=0.8V		330		μA
I _{DDQ_NSW2}		EN2=5V, EN1=EN3=0V, FB2=0.8V		330		μA
I _{DDQ_NSW3}		EN3=5V, EN1=EN2=0V, FB3=0.8V		330		μA
V _{7V}	V7V LDO output voltage	V _{7V} load current=0A	6	6.3	6.6	V
I _{OCP_V7V}	V7V LDO current limit			175		mA
FEEDBACK VOLTAGE REFERENCE						
V _{FB}	Feedback voltage	V _{COMP} = 1.2 V, T _J = 25°C	0.596	0.6	0.605	V
		V _{COMP} = 1.2 V, T _J = -40°C to 125°C	0.594	0.6	0.606	V
V _{LINEREG_BUCK}	Line regulation-DC	I _{OUT1} = 1.5A, I _{OUT2} = 1A, I _{OUT3} = 1A 5V < P _{VINx} < 18V		0.002		%/V
V _{LOADREG_BUCK}	Load regulation-DC	I _{OUTx} = (10–100%) × I _{OUTx_max}		0.02		%/A
Buck1, Buck2, Buck3						
V _{ENXH}	EN1/2/3 high level input voltage			1.2	1.26	V
V _{ENXL}	EN1/2/3 low level input voltage		1.1	1.15		V
I _{ENX1}	EN1/2/3 pull-up current	ENx = 1V		3.6		μA
I _{ENX2}	EN1/2/3 pull-up current	ENx = 1.5V		6.6		μA
I _{ENhys}	Hysteresis current			3		μA
I _{SSX}	Soft start charging current		4.3	5	6	μA
T _{ON_MIN}	Minimum on time			80	100	ns
G _{m_EA}	Error amplifier trans-conductance	-2 μA < I _{COMPx} < 2 μA		300		μS
G _{m_PS1/2/3}	COMP1/2/3 voltage to inductor current Gm	I _{LX} = 0.5 A		7.4		A/V
I _{LIMIT1}	Buck1 peak inductor current limit		4.33	5.1	6.02	A
I _{LIMITSOURCE1}	Buck1 low side source current limit			4.3		A
I _{LIMITSINK1}	Buck1 low side sink current limit			1.3		A
I _{LIMIT2/3}	Buck2/3 peak inductor current limit		2.6	3.1	3.73	A
I _{LIMITSOURCE2/3}	Buck2/3 low side source current limit			2.7		A
I _{LIMITSINK2/3}	Buck2/3 low side sink current limit			1		A
T _{Hiccup_wait}	Over current wait time			256		cycles
T _{Hiccup_re}	Hiccup time before re-start			8192		cycles
R _{dson_HS1}	Buck1 High-side switch resistance	VIN = 12V		100		mΩ
R _{dson_LS1}	Buck1 low-side switch resistance	VIN = 12V		65		mΩ
R _{dson_HS2}	Buck2 High-side switch resistance	VIN = 12V		140		mΩ
R _{dson_LS2}	Buck2 low-side switch resistance	VIN = 12V		95		mΩ
R _{dson_HS3}	Buck3 High-side switch resistance	VIN = 12V		140		mΩ
R _{dson_LS3}	Buck3 low-side switch resistance	VIN = 12V		95		mΩ

Electrical Characteristics (continued)
 $T_A = 25^\circ\text{C}$, $V_{IN} = 12\text{ V}$, $f_{SW} = 600\text{ kHz}$ (unless otherwise noted)

PARAMETER		TEST CONDITIONS	MIN	TYP	MAX	UNIT
POWER GOOD, MODE, POWER SEQUENCE						
V_{th_PG}	Feedback voltage threshold	FBx under-voltage Falling		92.5		$\%V_{REF}$
		FBx under-voltage Rising		95		$\%V_{REF}$
		FBx over-voltage Rising		107.5		$\%V_{REF}$
		FBx over-voltage Falling		105		$\%V_{REF}$
$T_{DEGLITCH(PG)_F}$	PGOOD falling edge deglitch time		128			cycles
$T_{RDEGLITCH(PG)_R}$	PGOOD rising edge deglitch time		512			cycles
I_{PG}	PGOOD pin leakage			0.05		μA
V_{LOW_PG}	PGOOD pin low voltage	$I_{SINK} = 1\text{ mA}$		0.4		V
V_{MODEH}	MODE high level input voltage			1.2	1.26	V
V_{MODEL}	MODE low level input voltage		1.1	1.15		V
I_{MODE1}	MODE pull-up current	MODE = 1V		3.6		μA
I_{MODE2}	MODE pull-up current	MODE = 1.5V		6.6		μA
$T_{psdelay}$	Delay time between bucks at automatic power sequencing mode	MODE = 1.5V		1024		cycles
POWER FAILURE DETECTOR						
V_{DIVth}	VDIV threshold		1.18	1.23	1.26	V
I_{VDIV}	VDIV pull-up current	VDIV = 1V		1		μA
		VDIV = 1.5V		2		μA
$I_{VDIVhys}$	VDIV hysteresis current			1		μA
$T_{deglitch_R}$	RESET deglitch on the rising edge			534		cycles
$T_{deglitch_F}$	RESET deglitch on the falling edge		12	14	16	cycles
OSCILLATOR						
F_{SW}	Switching frequency	ROSC = 73.2 k Ω	560	600	640	kHz
F_{SW_range}			250		2000	kHz
THERMAL PROTECTION						
T_{TRIP_OTP}	Thermal protection trip point	Temperature rising		160		$^\circ\text{C}$
T_{HYST_OTP}		Hysteresis		20		$^\circ\text{C}$

7.6 Typical Characteristics

$T_A = 25^\circ\text{C}$, $V_{IN} = 12\text{ V}$, $V_{OUT1} = 1.2\text{ V}$, $V_{OUT2} = 3.3\text{ V}$, $V_{OUT3} = 1.8\text{ V}$, $f_{SW} = 600\text{ kHz}$ (unless otherwise noted)

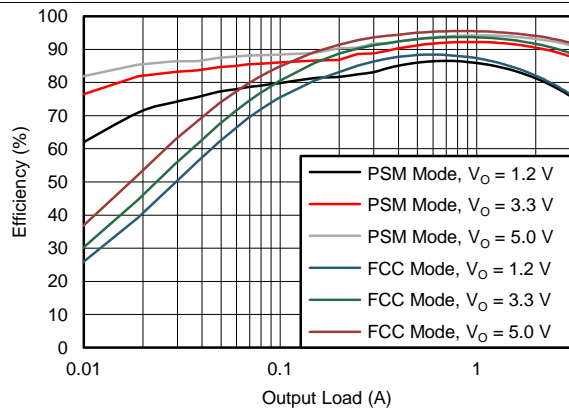

Figure 1. BUCK 1 Efficiency

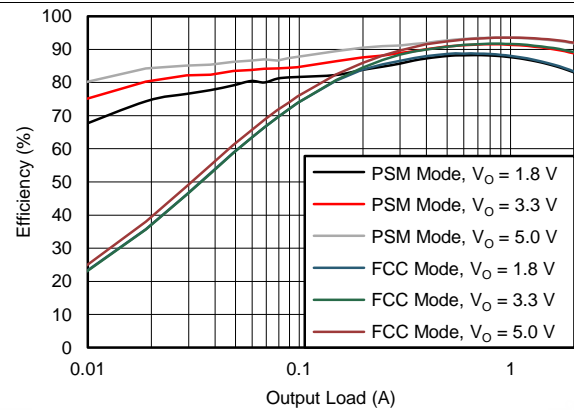

Figure 2. BUCK 2 Efficiency

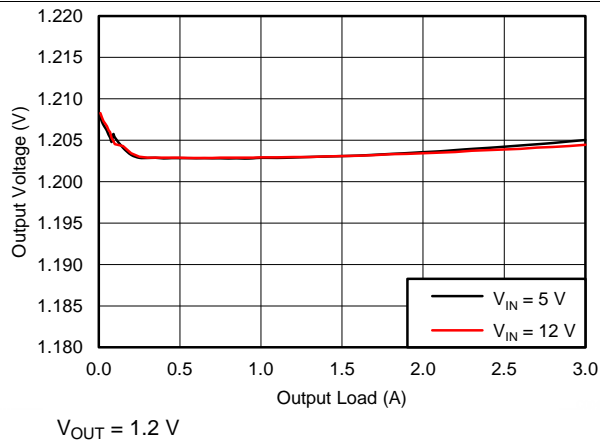

Figure 3. BUCK1, PSM Mode, Load Regulation

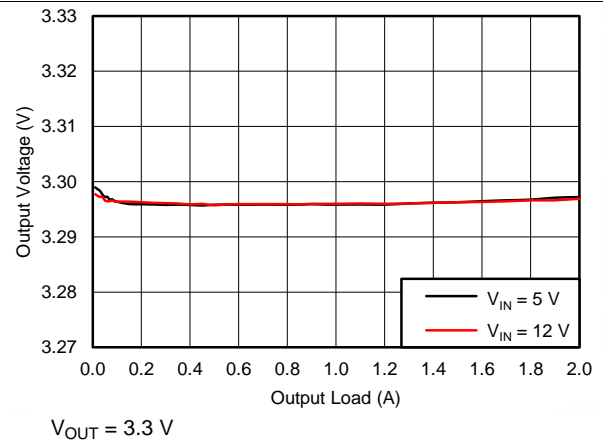

Figure 4. BUCK2, PSM Mode, Load Regulation

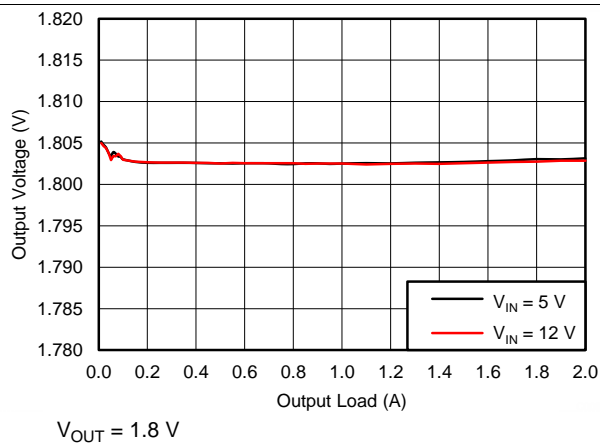

Figure 5. BUCK3, PSM Mode, Load Regulation

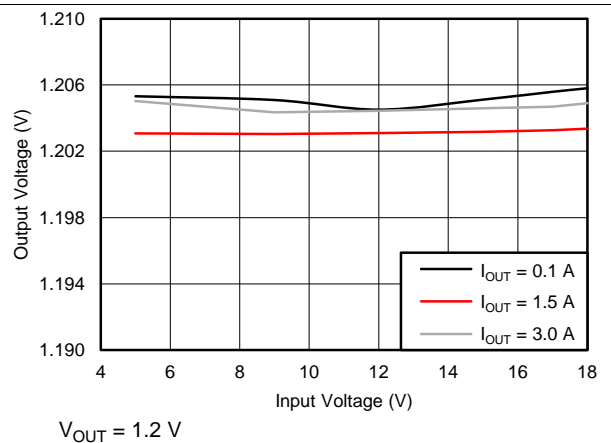

Figure 6. BUCK1, PSM Mode, Line Regulation

Typical Characteristics (continued)

$T_A = 25^\circ\text{C}$, $V_{IN} = 12\text{ V}$, $V_{OUT1} = 1.2\text{ V}$, $V_{OUT2} = 3.3\text{ V}$, $V_{OUT3} = 1.8\text{ V}$, $f_{SW} = 600\text{ kHz}$ (unless otherwise noted)

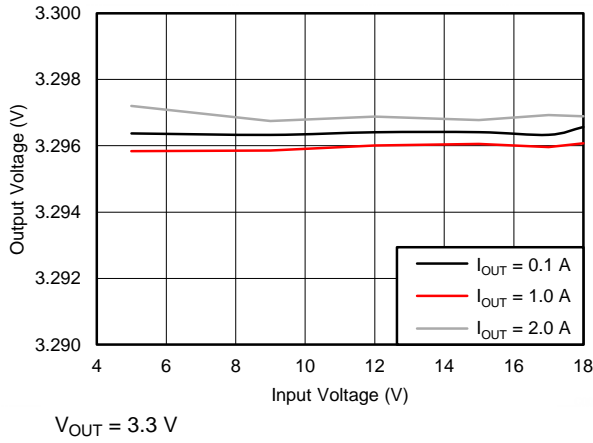

Figure 7. BUCK2, PSM MODE, LINE REGULATION

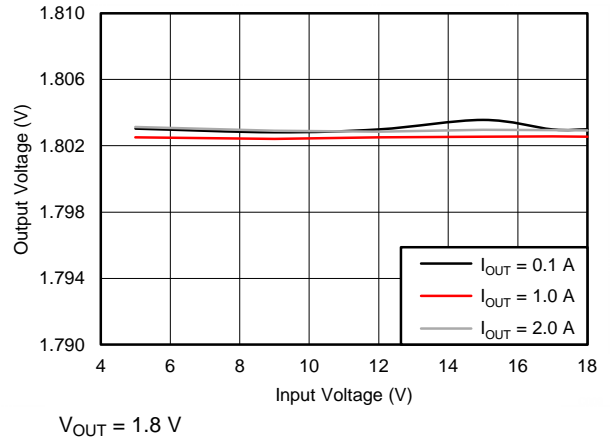

Figure 8. BUCK3, PSM Mode, Line Regulation

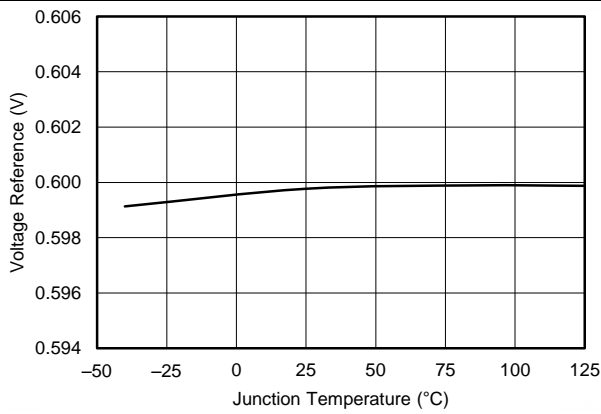

Figure 9. Voltage Reference vs Temperature

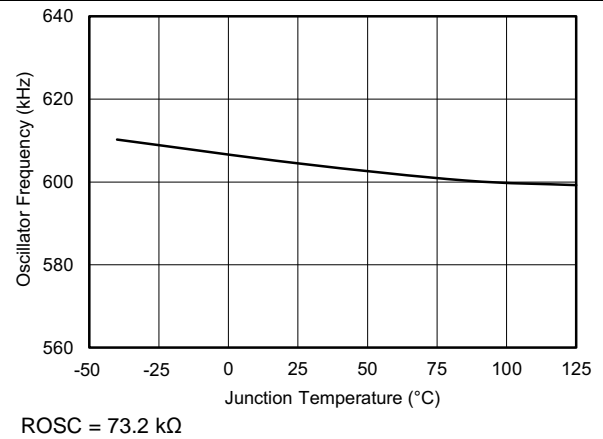

Figure 10. Oscillator Frequency vs Temperature

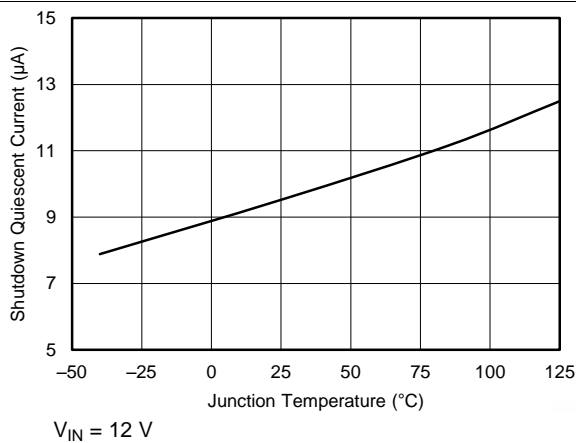

Figure 11. Shutdown Quiescent vs Temperature

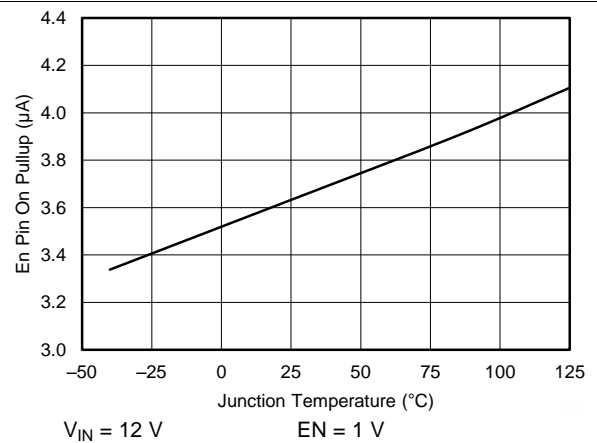

Figure 12. EN Pin Pull-Up Current vs Temperature, EN=1.0V

Typical Characteristics (continued)

$T_A = 25^\circ\text{C}$, $V_{IN} = 12\text{ V}$, $V_{OUT1} = 1.2\text{ V}$, $V_{OUT2} = 3.3\text{ V}$, $V_{OUT3} = 1.8\text{ V}$, $f_{SW} = 600\text{ kHz}$ (unless otherwise noted)

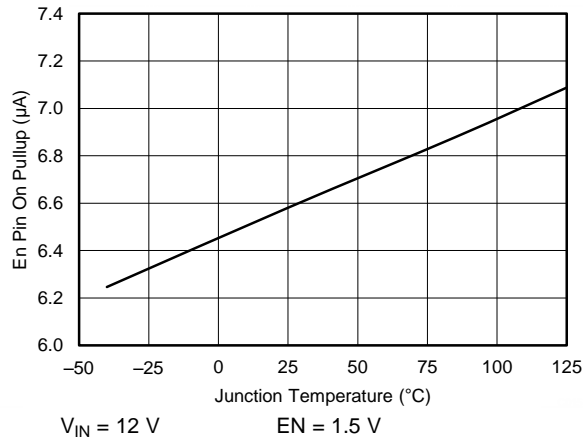

Figure 13. EN Pin Pull-Up Current vs Temperature, EN=1.5V

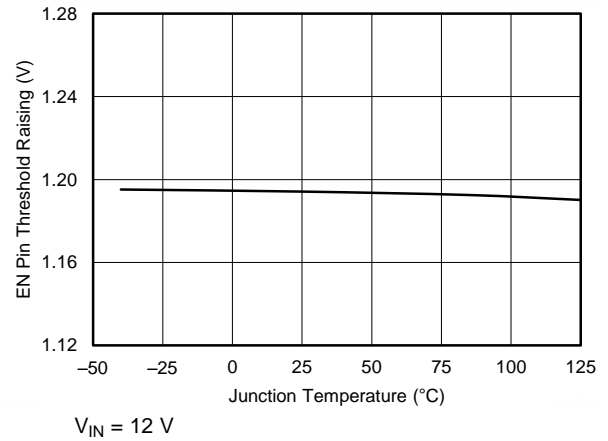

Figure 14. EN Pin Threshold Raising vs Temperature

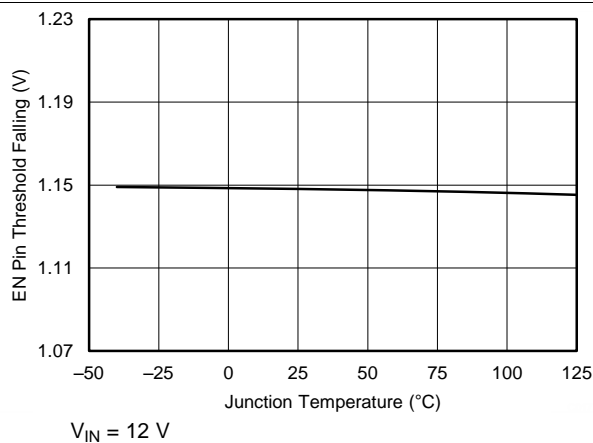

Figure 15. EN Pin Threshold Falling vs Temperature

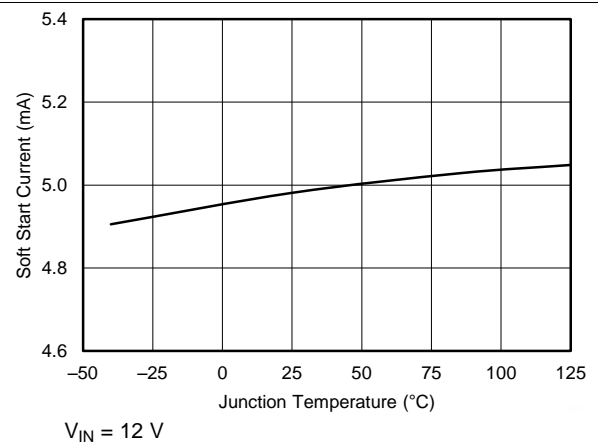

Figure 16. SS Pin Charge Current vs Temperature

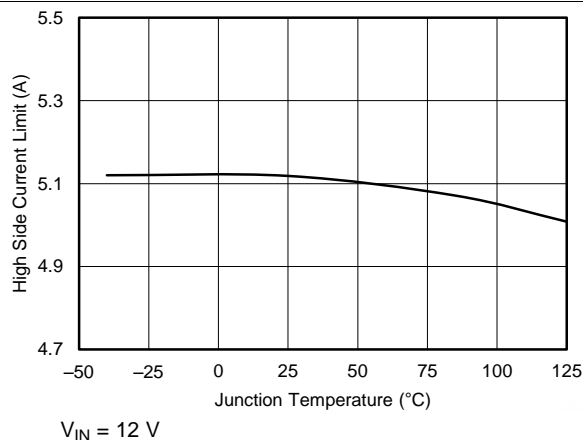

Figure 17. Buck1 High-Side Current Limit vs Temperature

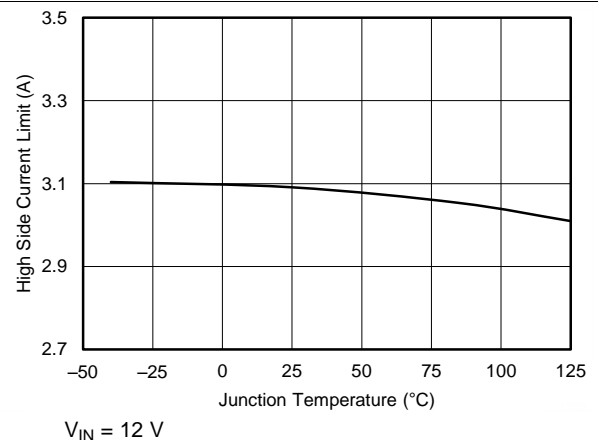

Figure 18. Buck2 High-Side Current Limit vs Temperature

Typical Characteristics (continued)

$T_A = 25^\circ\text{C}$, $V_{IN} = 12\text{ V}$, $V_{OUT1} = 1.2\text{ V}$, $V_{OUT2} = 3.3\text{ V}$, $V_{OUT3} = 1.8\text{ V}$, $f_{SW} = 600\text{ kHz}$ (unless otherwise noted)

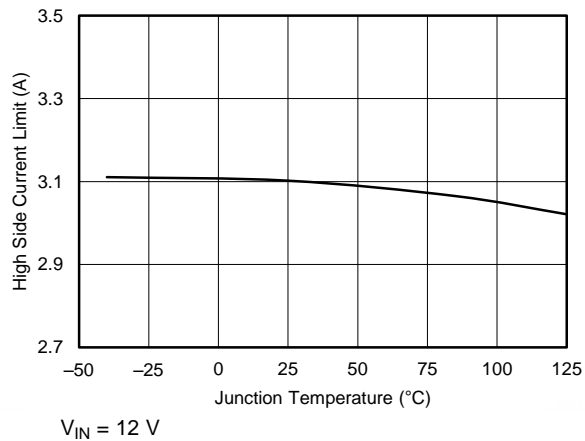

Figure 19. Buck3 High-Side Current Limit vs Temperature

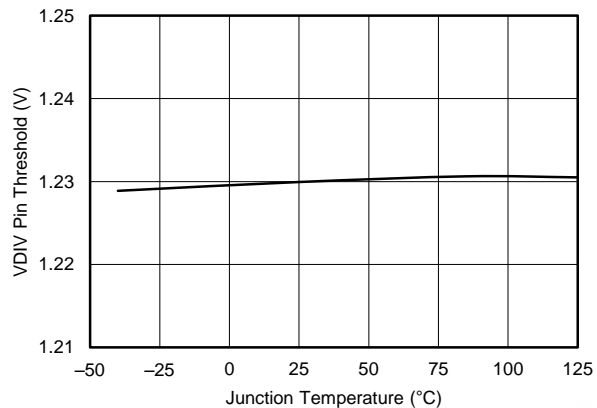

Figure 20. VDIV Pin Threshold vs Temperature

8 Detailed Description

8.1 Overview

The TPS65261, TPS65261-1 is a monolithic triple synchronous step-down (buck) converter with 3A/2A/2A output currents. A wide 4.5V to 18V input supply voltage range encompasses the most intermediate bus voltages operating off 5V, 9V, 12V or 15V power bus. The feedback voltage reference for each buck is 0.6V. Each buck is independent with dedicated enable, soft-start and loop compensation pins.

The TPS65261, TPS65261-1 implements a constant frequency, peak current mode control that simplifies external loop compensation. The wide switching frequency of 250kHz to 2MHz allows optimizing system efficiency, filtering size and bandwidth. The switching frequency can be adjusted with an external resistor connected between ROOSC pin and ground. The switching clock of buck1 is 180° out-of-phase operation from the clocks of buck2 and buck3 channels to reduce input current ripple, input capacitor size and power supply induced noise.

The TPS65261, TPS65261-1 has been designed for safe monotonic startup into pre-biased loads. The default start up is when VIN is typically 4.5V. The ENx pin also can be used to adjust the input voltage under voltage lockout (UVLO) with an external resistor divider. In addition, the ENx pin has an internal 3.6uA current source, so the EN pin can be floating to automatically power up the converters.

The TPS65261, TPS65261-1 reduces the external component count by integrating a bootstrap circuit. The bias voltage for the integrated high-side MOSFET is supplied by a capacitor between the BST and LX pin. A UVLO circuit monitors the bootstrap capacitor voltage VBST-VLX in each buck. When $V_{\text{BST-VLX}}$ voltage drops to the threshold, LX pin is pulled low to recharge the bootstrap capacitor. The TPS65261, TPS65261-1 can operate at 100% duty cycle as long as the bootstrap capacitor voltage is higher than the BOOT-LX UVLO threshold which is typically 2.1V.

The TPS65261, TPS65261-1 features a PGOOD pin to supervise each output voltage of the buck converters. The TPS65261, TPS65261-1 has power good comparators with hysteresis, which monitor the output voltages through feedback voltages. When all bucks are in regulation range and power sequence is done, PGOOD is asserted to high.

The SS (soft start/tracking) pin is used to minimize inrush currents or provide power supply sequencing during power up. A small value capacitor or resistor divider is connected to the pin for soft start or voltage tracking.

At light loading, TPS65261 will automatically operate in pulse skipping mode (PSM) to save power.

The TPS65261, TPS65261-1 is protected from overload and over temperature fault conditions. The converter minimizes excessive output overvoltage transients by taking advantage of the power good comparator. When the output is overvoltage, the high-side MOSFET is turned off until the internal feedback voltage is lower than 105% of the 0.6V reference voltage. The TPS65261, TPS65261-1 implements both high-side MOSFET overload protection and bidirectional low-side MOSFET overload protection to avoid inductor current runaway. If the over current condition has lasted for more than the OC wait time (256 clock cycles), the converter will shut down and re-start after the hiccup time (8192 clock cycles). The TPS65261, TPS65261-1 shuts down if the junction temperature is higher than the thermal shutdown trip point. When the junction temperature drops 20°C typically below the thermal shutdown trip point, the TPS65261, TPS65261-1 will be restarted under control of the soft start circuit automatically.

8.2 Functional Block Diagram

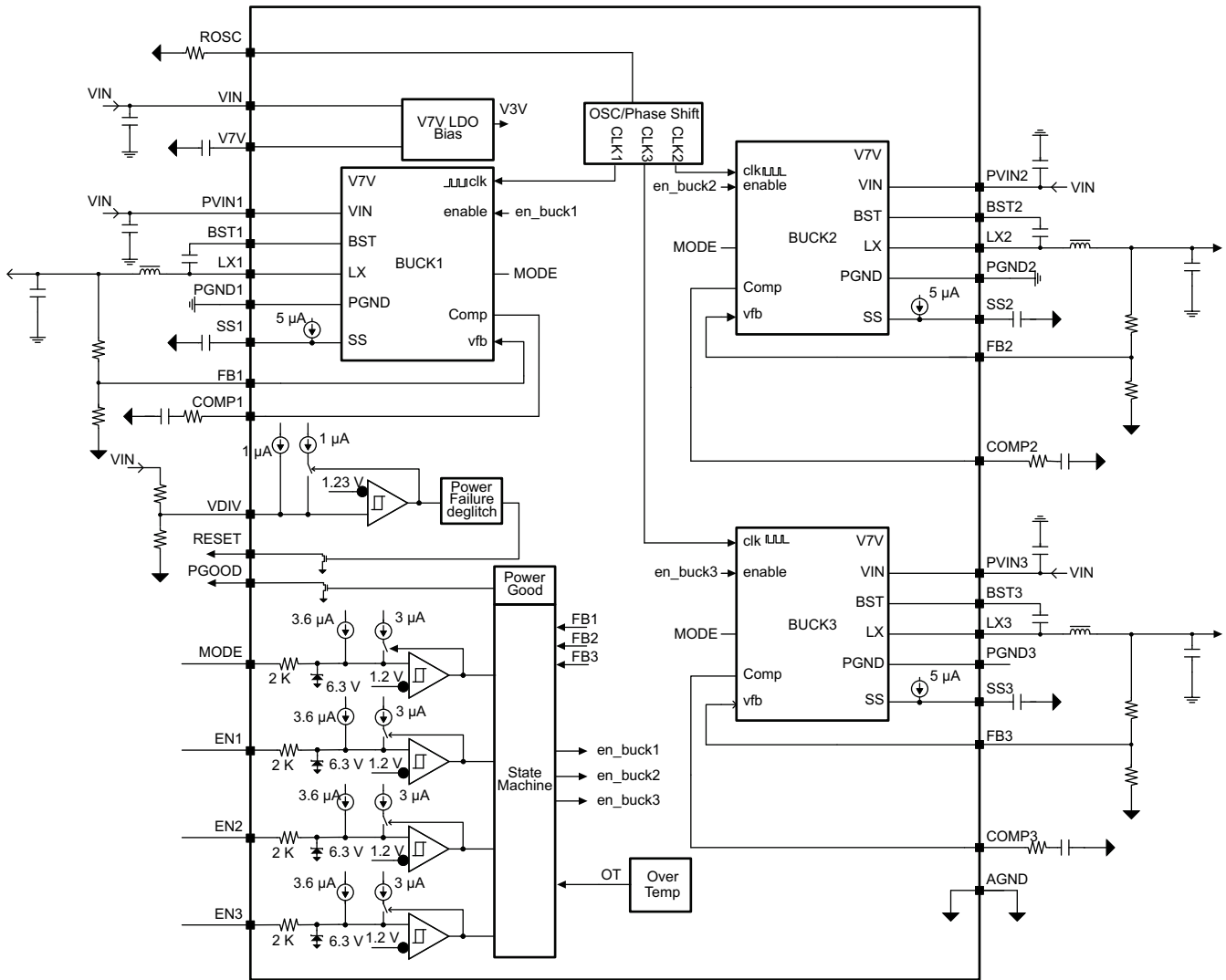

8.3 Feature Description

8.3.1 Adjusting the Output Voltage

The output voltage of each buck is set with a resistor divider from the output of buck to the FB pin. It is recommended to use 1% tolerance or better resistors.

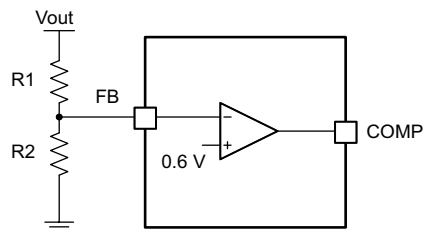

Figure 21. Voltage Divider Circuit

$$R_2 = R_1 \times \frac{0.6}{V_{out} - 0.6}$$

(1)

Feature Description (continued)

To improve efficiency at light loads, consider using larger value resistors. If the values are too high, the regulator is more sensitive to noise. The recommended resistor values are shown in [Table 1](#).

Table 1. Output Resistor Divider Selection

OUTPUT VOLTAGE (V)	R1 (kΩ)	R2 (kΩ)
1	10	15
1.2	10	10
1.5	15	10
1.8	20	10
2.5	31.6	10
3.3	45.3	10
3.3	22.6	4.99
5	73.2	10
5	36.5	4.99

8.3.2 Power Failure Detector

The power failure detector monitors the voltage on VDIV, and sets open-drain output RESET low when VDIV is below 1.23V. There is a glitch on the rising edge, 534 frequency cycles. [Figure 22](#) shows the power failure detector timing diagram.

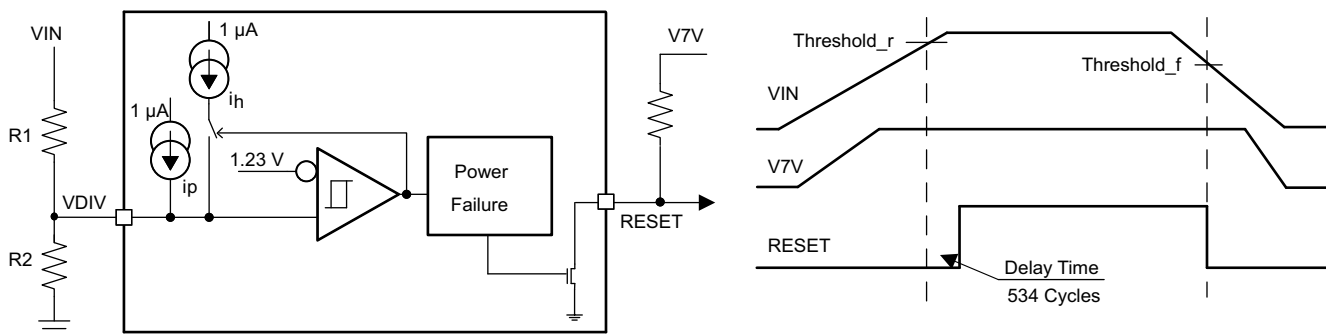

Figure 22. Power Failure Detector Timing Diagram

The thresholds can be calculated using [Equation 2](#) and [Equation 3](#).

$$\text{Threshold}_{-r} = V_{\text{ref}} \left(1 + \frac{R1}{R2} \right) - I_p \times R1 \quad (2)$$

$$\text{Threshold}_{-f} = V_{\text{ref}} \left(1 + \frac{R1}{R2} \right) - (I_p + I_h) \times R1 \quad (3)$$

The divider resistors can be calculated using [Equation 4](#) and [Equation 5](#).

$$R1 = \frac{\text{Threshold}_{-r} - \text{Threshold}_{-f}}{I_h} \quad (4)$$

$$R2 = \frac{V_{\text{ref}}}{\frac{\text{Threshold}_{-r} - V_{\text{ref}}}{\text{Threshold}_{-r} - \text{Threshold}_{-f}} \times I_h + I_p} \quad (5)$$

Where $I_h = 1\mu\text{A}$, $I_p = 1\mu\text{A}$.

8.3.3 Enable and Adjusting Under-Voltage Lockout

The EN1/2/3 pin provides electrical on/off control of the device. Once the EN1/2/3 pin voltage exceeds the threshold voltage, the device starts operation. If each ENx pin voltage is pulled below the threshold voltage, the regulator stops switching and enters low Iq state.

The EN pin has an internal pull-up current source, allowing the user to float the EN pin to enable the device. If an application requires controlling the EN pin, use open drain or open collector output logic to interface with the pin.

The device implements internal UVLO circuitry on the VIN pin. The device is disabled when the VIN pin voltage falls below the internal VIN UVLO threshold. The internal VIN UVLO threshold has a hysteresis of 500mV. If an application requires either a higher UVLO threshold on the VIN pin or a secondary UVLO on the PVINx in split rail applications, then the ENx pin can be configured as shown in [Figure 23](#), [Figure 24](#) and [Figure 25](#). When using the external UVLO function, it is recommended to set the hysteresis to be greater than 500mV.

The EN pin has a small pull-up current I_p which sets the default state of the pin to enable when no external components are connected. The pull-up current is also used to control the voltage hysteresis for the UVLO function since it increases by I_h once the EN pin crosses the enable threshold. The UVLO thresholds can be calculated using [Equation 6](#) and [Equation 7](#).

$$R_1 = \frac{V_{\text{START}} \left(\frac{V_{\text{ENFALLING}}}{V_{\text{ENRISING}}} \right) - V_{\text{STOP}}}{I_p \left(1 - \frac{V_{\text{ENFALLING}}}{V_{\text{ENRISING}}} \right) + I_h} \quad (6)$$

$$R_2 = \frac{R_1 \times V_{\text{ENFALLING}}}{V_{\text{STOP}} - V_{\text{ENFALLING}} + R_1 (I_h + I_p)} \quad (7)$$

Where $I_h = 3\mu\text{A}$, $I_p = 3.6\mu\text{A}$, $V_{\text{ENRISING}} = 1.2\text{V}$, $V_{\text{ENFALLING}} = 1.15\text{V}$.

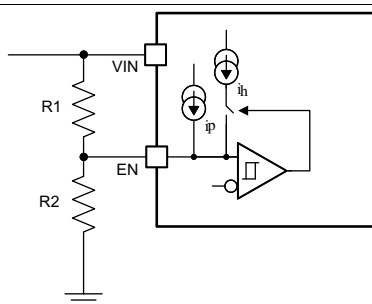

Figure 23. Adjustable VIN Under-voltage Lockout

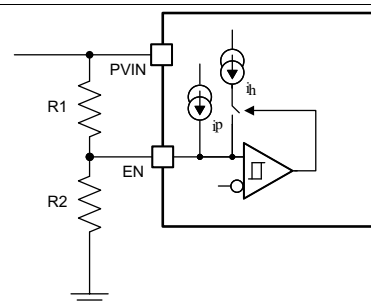
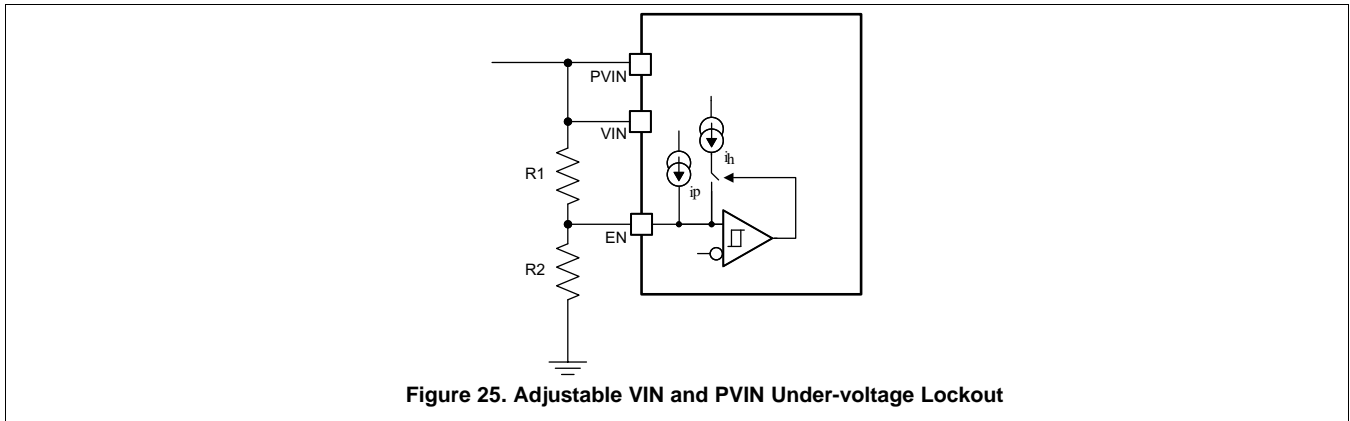

Figure 24. Adjustable PVIN Under-voltage Lockout, VIN > 4.5V



8.3.4 Soft-Start Time

The voltage on the respective SS pin controls the start-up of the buck output. When the voltage on the SS pin is less than the internal 0.6V reference, the TPS65261, TPS65261-1 regulates the internal feedback voltage to the voltage on the SS pin instead of 0.6V. The SS pin can be used to program an external soft-start function or to allow output of the buck to track another supply during start-up. The device has an internal pull-up current source of 5μA (typical) that charges an external soft-start capacitor to provide a linear ramping voltage at the SS pin. The TPS65261, TPS65261-1 regulates the internal feedback voltage to the voltage on the SS pin, allowing VOUT to rise smoothly from 0V to its regulated voltage without inrush current. The soft-start time can be calculated approximately by [Equation 8](#).

$$T_{ss}(ms) = \frac{C_{ss}(nF) \times V_{ref}(V)}{I_{ss}(\mu A)} \quad (8)$$

Many of the common power supply sequencing methods can be implemented using the SSx and ENx pins. [Figure 26](#) shows the method implementing ratio-metric sequencing by connecting the SSx pins of three buck channels together. The regulator outputs ramp up and reach regulation at the same time. When calculating the soft-start time, the pull-up current source must be tripled in [Equation 8](#).

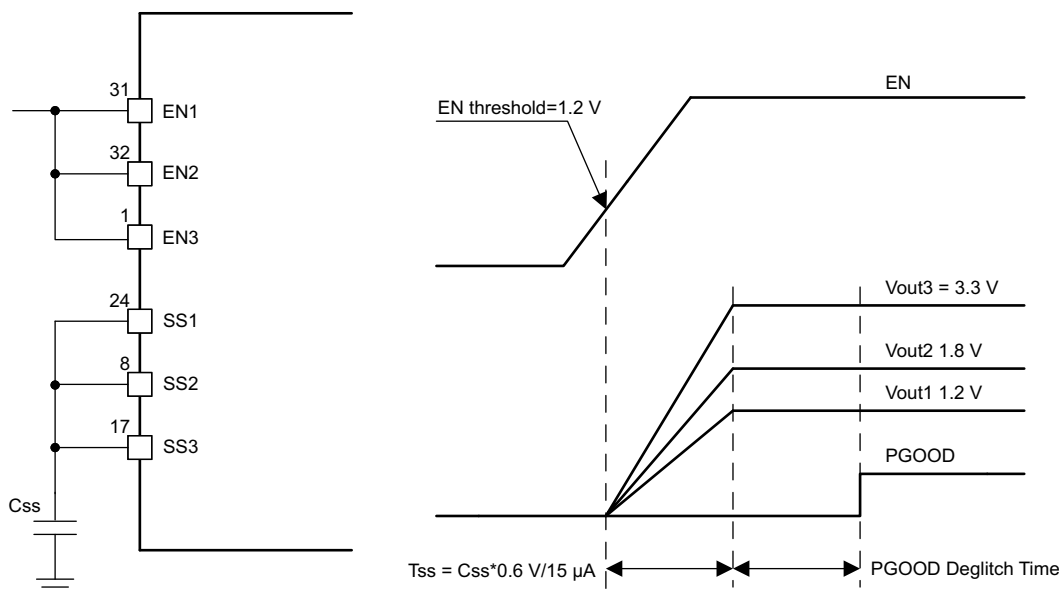

Simultaneous power supply sequencing can be implemented by connecting capacitor to SSx pin, shown in Figure 27. The capacitors can be calculated using Equation 8 and Equation 9.

$$\frac{C_{ss1}}{V_{out1}} = \frac{C_{ss2}}{V_{out2}} = \frac{C_{ss3}}{V_{out3}} \quad (9)$$

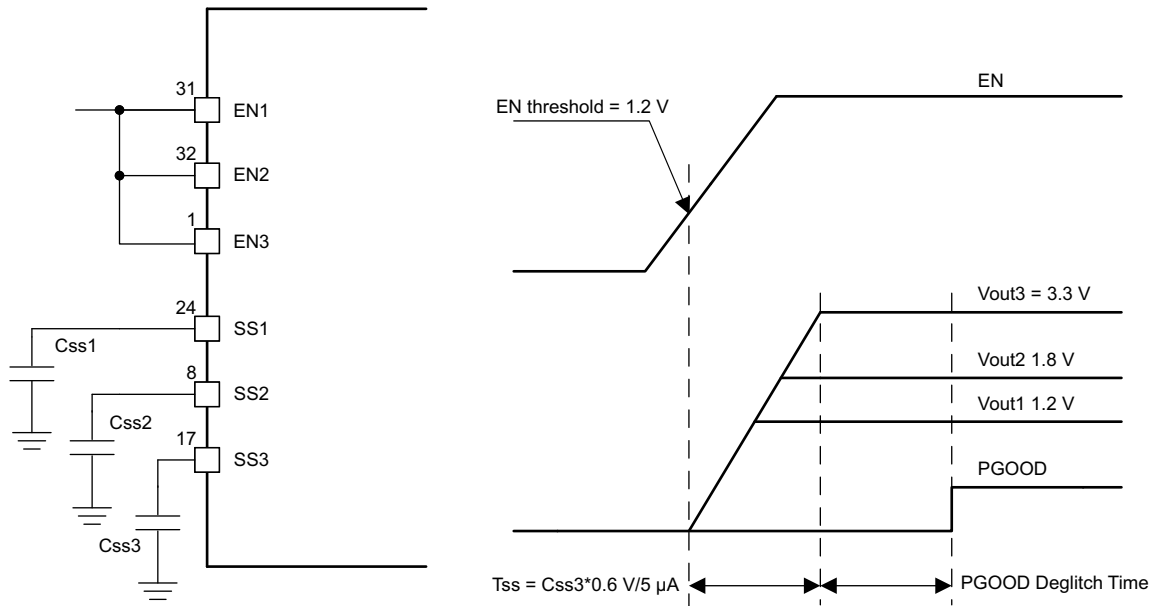

Figure 27. Simultaneous Startup Sequence Using SSx Pins

8.3.5 Power Up Sequencing

TPS65261, TPS65261-1 features a comprehensive sequencing circuit for the 3 bucks. If the MODE pin ties high to V7V, three buck start up and shutdown is in sequence according to different buck enable pin setup. If the MODE pin ties low to ground, three buck on/off is separately controlled by three enable pins.

8.3.5.1 External Power Sequencing

The TPS65261, TPS65261-1 has a dedicated enable pin and soft-start pin for each converter. The converter enable pins are biased by a current source that allows for easy sequencing with the addition of an external capacitor. Disabling the converter with an active pull-down transistor on the ENs pin allows for a predictable power-down timing operation. Figure 28 shows the timing diagram of a typical buck power-up sequence by connecting a capacitor at ENx pin.

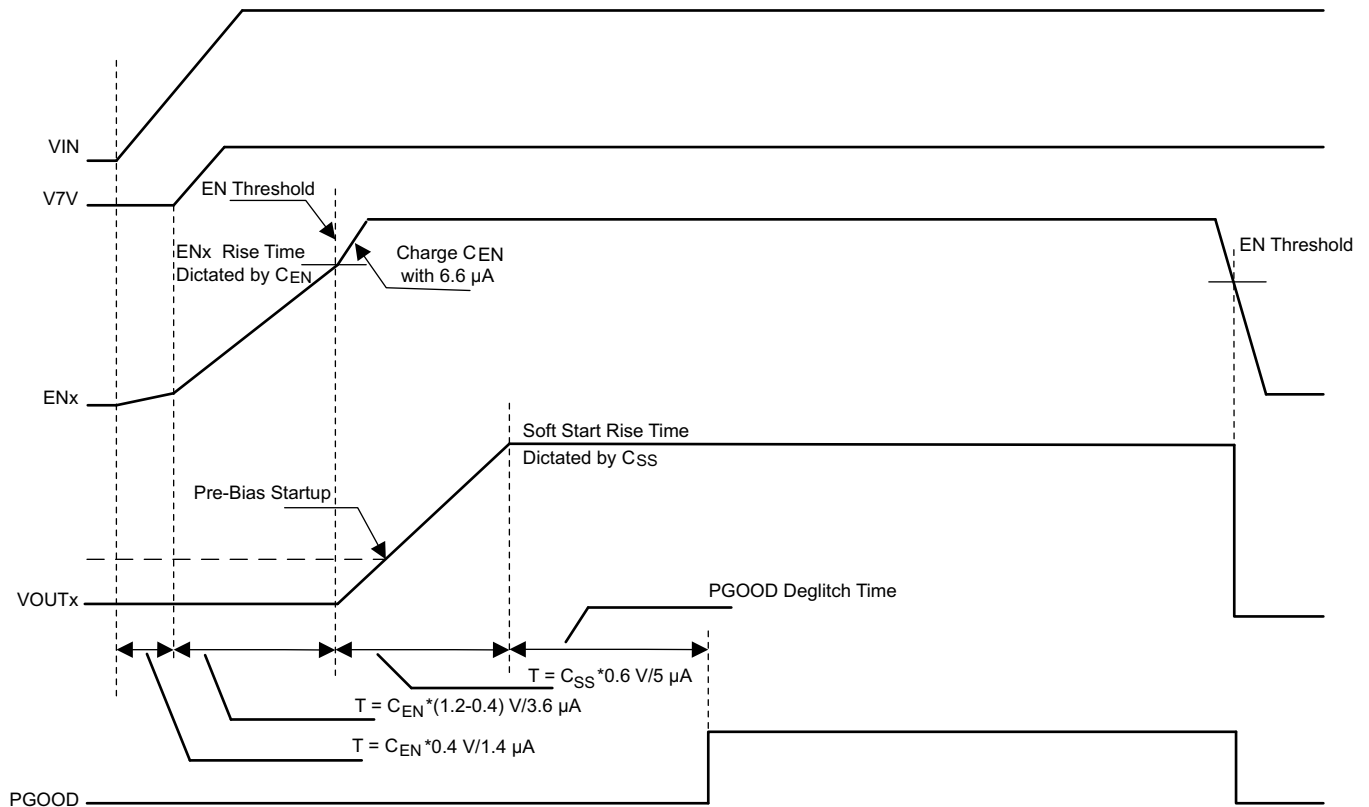
Figure 28. Startup Power Sequence

8.3.5.2 Automatic Power Sequencing

The TPS65261, TPS65261-1 starts with a pre-defined power-up and power-down sequence when the MODE pin ties high to V7V. As shown in Table 2, the sequence is dictated by the different combinations of EN1 and EN2 status. EN3 is used to start/stop the converters. Buck2 and buck3 are identical converters and can be swapped in the system operation to allow for additional sequencing stages. Figure 29 shows the power sequencing when EN1 and EN2 are pulled up high.

Table 2. Power Sequencing

	MODE	EN1	EN2	EN3	Start Sequencing	Shutdown Sequencing
Automatic Power Sequencing	High	High	High	Used to start/stop bucks in sequence	Buck1→Buck2→Buck3	Buck3→Buck2→Buck1
	High	Low	High		Buck2→Buck1→Buck3	Buck3→Buck1→Buck2
	High	High	Low		Buck2→Buck3→Buck1	Buck1→Buck3→Buck2
	High	Low	Low	Reserved	Reserved	Reserved
Externally controlled sequencing	Low	Used to start/stop buck1	Used to start/stop buck2	Used to start/stop buck3	x	x

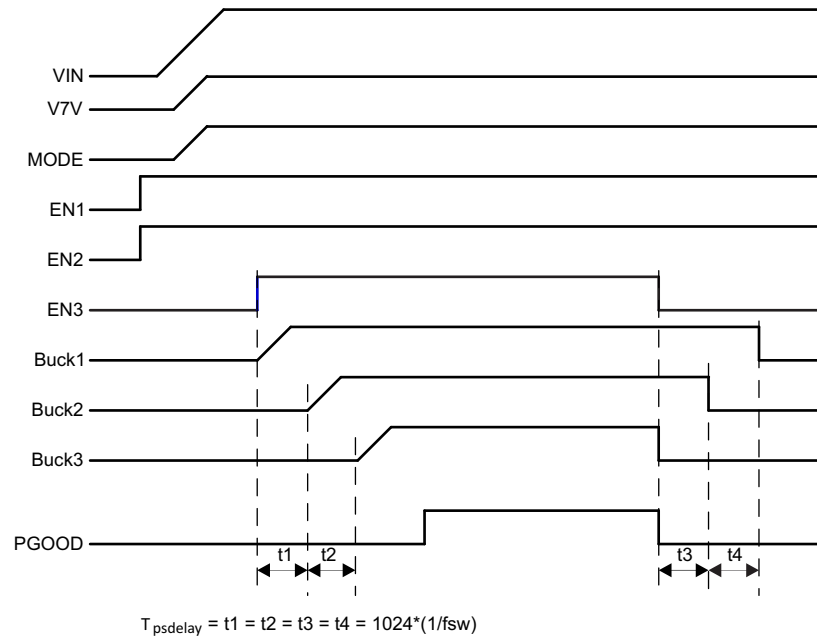

Figure 29. Automatic Power Sequencing

8.3.6 V7V Low Dropout Regulator and Bootstrap

Power for the high-side and low-side MOSFET drivers and most other internal circuitry is derived from the V7V pin. The internal built-in low dropout linear regulator (LDO) supplies 6.3V (typical) from VIN to V7V. A 1µF ceramic capacitor should be connected from V7V pin to power ground.

If the input voltage, VIN, decreases to UVLO threshold voltage, the UVLO comparator detects the V7V pin voltage and forces the converter off.

Each high-side MOSFET driver is biased from the floating bootstrap capacitor, CB, shown in [Figure 30](#), which is normally recharged during each cycle through an internal low-side MOSFET or the body diode of a low-side MOSFET when the high-side MOSFET turns off. The boot capacitor is charged when the BST pin voltage is less than VIN and BST-LX voltage is below regulation. The recommended value of this ceramic capacitor is 47nF. A ceramic capacitor with an X7R or X5R grade dielectric with a voltage rating of 10V or higher is recommended because of the stable characteristics over temperature and voltage. Each low-side MOSFET driver is powered from the V7V pin directly.

To improve drop out, the device is designed to operate at 100% duty cycle as long as the BST to LX pin voltage is greater than the BST-LX UVLO threshold, which is typically 2.1V. When the voltage between BST and LX drops below the BST-LX UVLO threshold, the high-side MOSFET is turned off and the low-side MOSFET is turned on allowing the boot capacitor to be recharged.

8.3.10.1 High-side MOSFET Over Current Protection

The device implements current mode control which uses the COMP pin voltage to control the turn off of the high-side MOSFET and the turn on of the low-side MOSFET on a cycle-by-cycle basis. During each cycle, the switch current and the current reference generated by the COMP pin voltage are compared, when the peak switch current intersects the current reference, the high-side switch is turned off.

8.3.10.2 Low-side MOSFET Over Current Protection

While the low-side MOSFET is turned on, its conduction current is monitored by the internal circuitry. During normal operation, the low-side MOSFET sources current to the load. At the end of every clock cycle, the low-side MOSFET sourcing current is compared to the internally set low-side sourcing current limit. If the low-side sourcing current is exceeded, the high-side MOSFET is not turned on and the low-side MOSFET stays on for the next cycle. The high-side MOSFET is turned on again when the low-side current is below the low-side sourcing current limit at the start of a cycle.

The low-side MOSFET may also sink current from the load. If the low-side sinking current limit is exceeded, the low-side MOSFET is turned off immediately for the rest of that clock cycle. In this scenario both MOSFETs are off until the start of the next cycle.

Furthermore, if an output overload condition (as measured by the COMP pin voltage) has lasted for more than the hiccup wait time which is programmed for 256 switching cycles shown in Figure 31, the device will shut down itself and restart after the hiccup time of 8192 cycles. The hiccup mode helps reduce the device power dissipation under severe overcurrent condition.

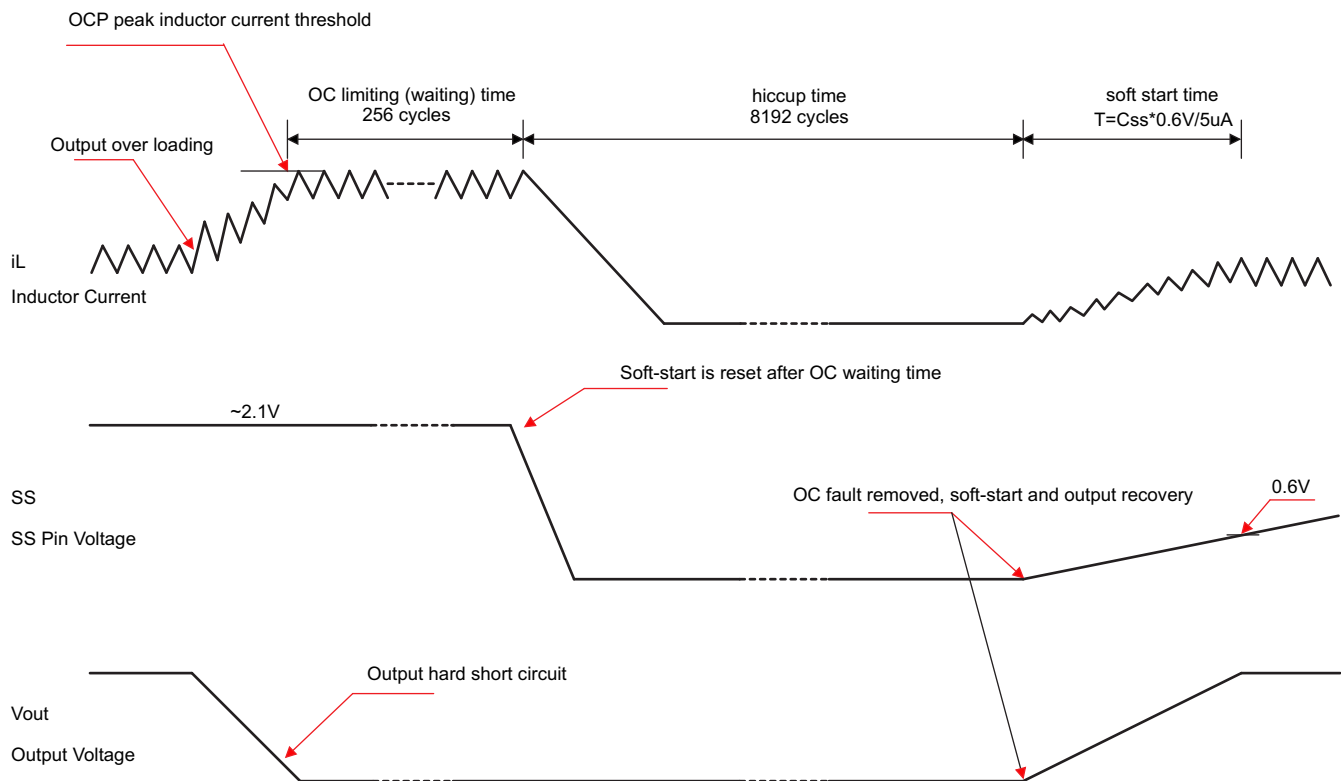

Figure 31. Over Current Protection

8.3.11 Power Good

The PGOOD pin is an open drain output. Once feedback voltage of each buck is between 95% (rising) and 105% (falling) of the internal voltage reference, the PGOOD pin pull-down is de-asserted and the pin floats. It is recommended to use a pull-up resistor between the values of 10kΩ and 100kΩ to a voltage source that is 5.5V or less. The PGOOD is in a defined state once the VIN input voltage is greater than 1V, but with reduced current sinking capability. The PGOOD achieves full current sinking capability once the VIN input voltage is above UVLO threshold, which is 4.25V.

The PGOOD pin is pulled low when any feedback voltage of a buck is lower than 92.5% (falling) or greater than 107.5% (rising) of the nominal internal reference voltage. Also, the PGOOD is pulled low if the input voltage is under-voltage locked up, thermal shutdown is asserted, the EN pin is pulled low or the converter is in a soft-start period.

8.3.12 Adjustable Switching Frequency

The ROSC pin can be used to set the switching frequency by connecting a resistor to GND. The switching frequency of the device is adjustable from 250KHz to 2MHz.

To determine the ROSC resistance for a given switching frequency, use [Equation 10](#) or the curve in [Figure 32](#). To reduce the solution size, set the switching frequency as high as possible, but tradeoffs of the supply efficiency and minimum controllable on time should be considered.

$$f_{\text{osc}} (\text{kHz}) = 39557 \times R(\text{k}\Omega)^{-0.975} \quad (10)$$

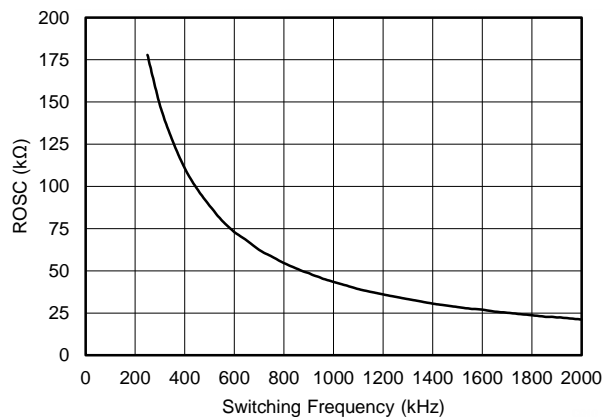

Figure 32. ROSC versus Switching Frequency

8.3.13 Thermal Shutdown

The internal thermal shutdown circuitry forces the device to stop switching if the junction temperature exceeds 160°C typically. The device reinitiates the power up sequence when the junction temperature drops below 140°C typically.

8.4 Device Functional Modes

8.4.1 Pulse Skipping MODE (PSM)

The TPS65261 can enter high efficiency pulse skipping mode (PSM) operation at light load current.

When a controller is enabled for PSM operation, the peak inductor current is sensed and compared with 230mA current typically. Since the integrated current comparator catches the peak inductor current only, the average load current entering PSM varies with applications and external output filters. In PSM, the sensed peak inductor current is clamped at 230mA.

When a controller operates in PSM, the inductor current is not allowed to reverse. The reverse current comparator turns off the low-side MOSFET when the inductor current reaches zero, preventing it from reversing and going negative.

Due to the delay in the circuit and current comparator t_{dly} (typical 50ns at $V_{IN} = 12V$), the real peak inductor current threshold to turn off high-side power MOSFET, could shift higher depending on inductor inductance and input/output voltages. The threshold of peak inductor current to turn off high-side power MOSFET can be calculated by [Equation 11](#).

$$I_{L_{PEAK}} = 230 \text{ mA} + \frac{V_{in} - V_{out}}{L} \times t_{dly} \quad (11)$$

Device Functional Modes (continued)

Once the charge accumulated on the Vout capacitor is more than loading need, COMP pin voltage drops to low voltage driven by the error amplifier. There is an internal comparator at the COMP pin. If COMP voltage is lower than 0.35V, the power stage stops switching to save power.

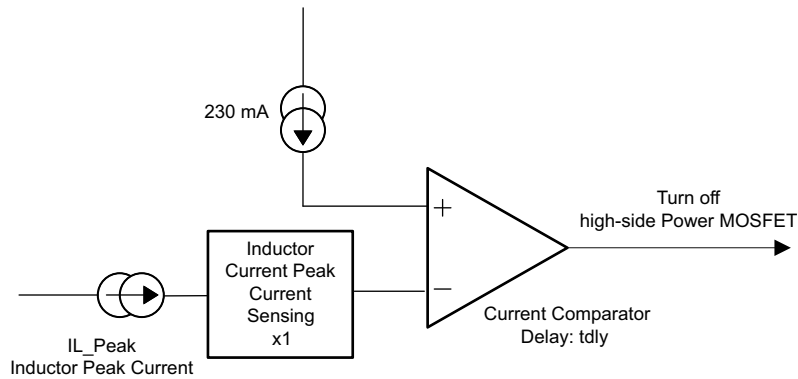

Figure 33. PSM Current Comparator

9 Application and Implementation

9.1 Application Information

The devices are triple synchronous step down dc/dc converters. They are typically used to convert a higher dc voltage to lower dc voltages with continuous available output current of 3A/2A/2A. The following design procedure can be used to select component values for the TPS65261 and TPS65261-1. This section presents a simplified discussion of the design process.

9.2 Typical Application

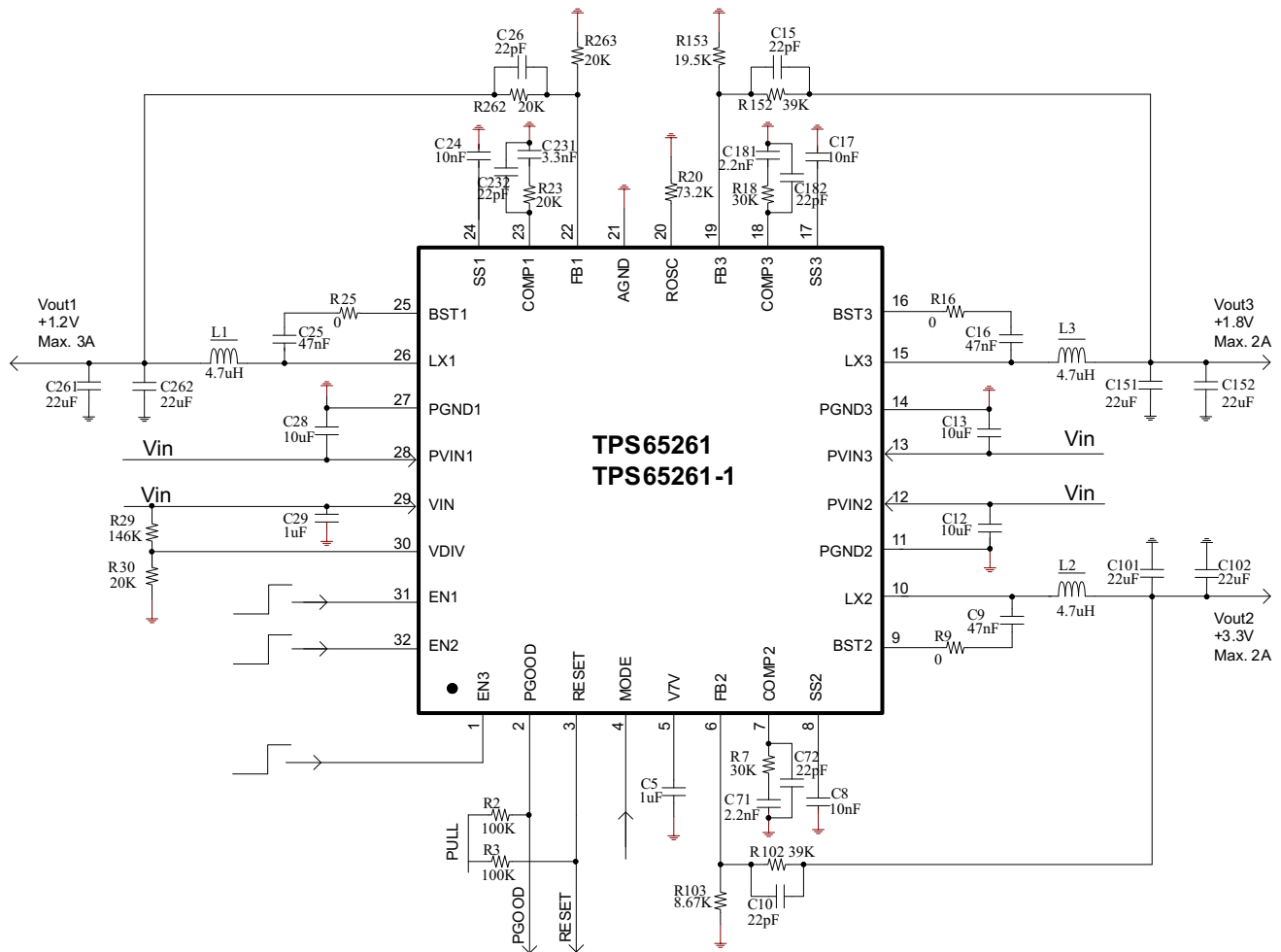

Figure 34. Typical Application Schematic

Typical Application (continued)

9.2.1 Design Requirements

This example details the design of triple synchronous step-down converter. A few parameters must be known in order to start the design process. These parameters are typically determined at the system level. For this example, we start with the following known parameters:

Table 3. Design Parameters

DESIGN PARAMETER	EXAMPLE VALUE
V _{out1}	1.2 V
I _{out1}	3 A
V _{out2}	3.3 V
I _{out2}	2 A
V _{out3}	1.8 V
I _{out3}	2 A
Transient Response 1A Load Step	±5%
Input Voltage	12 V normal, 4.5 V to 18 V
Output Voltage Ripple	±1%
Switching Frequency	600 kHz

9.2.2 Detailed Design Procedure

9.2.2.1 Output Inductor Selection

To calculate the value of the output inductor, use [Equation 12](#). LIR is a coefficient that represents the amount of inductor ripple current relative to the maximum output current. The inductor ripple current is filtered by the output capacitor. Therefore, choosing high inductor ripple currents impact the selection of the output capacitor since the output capacitor must have a ripple current rating equal to or greater than the inductor ripple current. In general, the inductor ripple value is at the discretion of the designer; however, LIR is normally from 0.1 to 0.3 for the majority of applications.

$$L = \frac{V_{in,max} - V_{out}}{I_o \times LIR} \times \frac{V_{out}}{V_{in,max} \times f_{sw}} \quad (12)$$

For the output filter inductor, it is important that the RMS current and saturation current ratings not be exceeded. The RMS and peak inductor current can be found from [Equation 14](#) and [Equation 15](#).

$$I_{ripple} = \frac{V_{in,max} - V_{out}}{L} \times \frac{V_{out}}{V_{in,max} \times f_{sw}} \quad (13)$$

$$I_{Lrms} = \sqrt{I_o^2 + \frac{\left(\frac{V_{out} \times (V_{in,max} - V_{out})}{V_{in,max} \times L \times f_{sw}} \right)^2}{12}} \quad (14)$$

$$I_{Lpeak} = I_o + \frac{I_{ripple}}{2} \quad (15)$$

The current flowing through the inductor is the inductor ripple current plus the output current. During power up, faults or transient load conditions, the inductor current can increase above the calculated peak inductor current level calculated above. In transient conditions, the inductor current can increase up to the switch current limit of the device. For this reason, the most conservative approach is to specify an inductor with a saturation current rating equal to or greater than the switch current limit rather than the peak inductor current.

9.2.2.2 Output Capacitor Selection

There are three primary considerations for selecting the value of the output capacitor. The output capacitor determines the modulator pole, the output voltage ripple, and how the regulator responds to a large change in load current. The output capacitance needs to be selected based on the most stringent of these three criteria.

The desired response to a large change in the load current is the first criteria. The output capacitor needs to supply the load with current when the regulator cannot. This situation would occur if there are desired hold-up times for the regulator where the output capacitor must hold the output voltage above a certain level for a specified amount of time after the input power is removed. The regulator is also temporarily not able to supply sufficient output current if there is a large, fast increase in the current needs of the load such as a transition from no load to full load. The regulator usually needs two or more clock cycles for the control loop to see the change in load current and output voltage and adjust the duty cycle to react to the change. The output capacitor must be sized to supply the extra current to the load until the control loop responds to the load change. The output capacitance must be large enough to supply the difference in current for 2 clock cycles while only allowing a tolerable amount of drop in the output voltage. Equation 16 shows the minimum output capacitance necessary to accomplish this.

$$C_o = \frac{2 \times \Delta I_{out}}{f_{sw} \times \Delta V_{out}} \quad (16)$$

Where ΔI_{out} is the change in output current, f_{sw} is the regulators switching frequency and ΔV_{out} is the allowable change in the output voltage.

Equation 17 calculates the minimum output capacitance needed to meet the output voltage ripple specification. Where f_{sw} is the switching frequency, V_{ripple} is the maximum allowable output voltage ripple, and I_{ripple} is the inductor ripple current.

$$C_o > \frac{1}{8 \times f_{sw}} \times \frac{1}{\frac{V_{ripple}}{I_{ripple}}} \quad (17)$$

Equation 18 calculates the maximum ESR an output capacitor can have to meet the output voltage ripple specification.

$$R_{esr} < \frac{V_{ripple}}{I_{ripple}} \quad (18)$$

Additional capacitance de-ratings for aging, temperature and DC bias should be factored in, which increases this minimum value. Capacitors generally have limits to the amount of ripple current they can handle without failing or producing excess heat. An output capacitor that can support the inductor ripple current must be specified. Some capacitor data sheets specify the root mean square (RMS) value of the maximum ripple current. Equation 19 can be used to calculate the RMS ripple current the output capacitor needs to support.

$$I_{corms} = \frac{V_{out} \times (V_{inmax} - V_{out})}{\sqrt{12} \times V_{inmax} \times L \times f_{sw}} \quad (19)$$

9.2.2.3 Input Capacitor Selection

The TPS65261, TPS65261-1 requires a high quality ceramic, type X5R or X7R, input decoupling capacitor of at least 10 μ F of effective capacitance on the PVIN input voltage pins. In some applications, additional bulk capacitance may also be required for the PVIN input. The effective capacitance includes any DC bias effects. The voltage rating of the input capacitor must be greater than the maximum input voltage. The capacitor must also have a ripple current rating greater than the maximum input current ripple of The TPS65261, TPS65261-1. The input ripple current can be calculated using Equation 20.

$$I_{inrms} = I_{out} \times \sqrt{\frac{V_{out}}{V_{inmin}} \times \frac{(V_{inmin} - V_{out})}{V_{inmin}}} \quad (20)$$

The value of a ceramic capacitor varies significantly over temperature and the amount of DC bias applied to the capacitor. The capacitance variations due to temperature can be minimized by selecting a dielectric material that is stable over temperature. X5R and X7R ceramic dielectrics are usually selected for power regulator capacitors because they have a high capacitance to volume ratio and are fairly stable over temperature. The output capacitor must also be selected with the DC bias taken into account. The capacitance value of a capacitor decreases as the DC bias across a capacitor increases. The input capacitance value determines the input ripple voltage of the regulator. The input voltage ripple can be calculated using Equation 21.

$$\Delta V_{in} = \frac{I_{outmax} \times 0.25}{C_{in} \times f_{sw}} \quad (21)$$

9.2.2.4 Loop Compensation

The TPS65261, TPS65261-1 incorporates a peak current mode control scheme. The error amplifier is a trans-conductance amplifier with a gain of 300 μS . A typical type II compensation circuit adequately delivers a phase margin between 60° and 90°. C_b adds a high frequency pole to attenuate high frequency noise when needed. To calculate the external compensation components, follow these steps.

1. Select switching frequency f_{sw} that is appropriate for application depending on L and C sizes, output ripple, and EMI. Switching frequency between 500kHz to 1MHz gives best trade-off between performance and cost. To optimize efficiency, lower switching frequency is desired.
2. Set up cross over frequency, f_c , which is typically between 1/5 and 1/20 of f_{sw} .
3. R_C can be determined by

$$R_C = \frac{2\pi \times f_c \times V_o \times C_o}{G_{m_EA} \times V_{ref} \times G_{m_PS}} \quad (22)$$

Where G_{m_EA} is the error amplifier gain (300 μS), G_{m_PS} is the power stage voltage to current conversion gain (7.4A/V).

4. Calculate C_C by placing a compensation zero at or before the dominant pole $\left(f_p = \frac{1}{C_o \times R_L \times 2\pi} \right)$.

$$C_C = \frac{R_L \times C_o}{R_C} \quad (23)$$

5. Optional C_b can be used to cancel the zero from the ESR associated with C_o .

$$C_b = \frac{R_{ESR} \times C_o}{R_C} \quad (24)$$

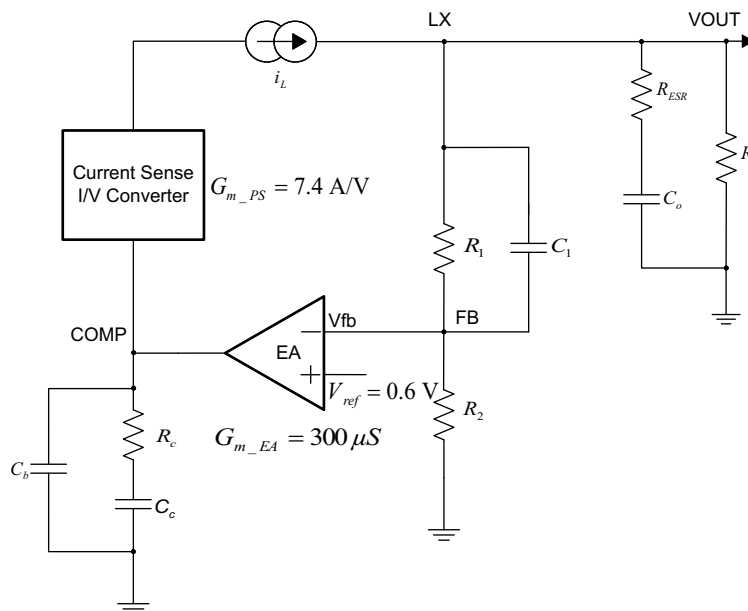

Figure 35. DC/DC Loop Compensation

9.2.3 Application Curves

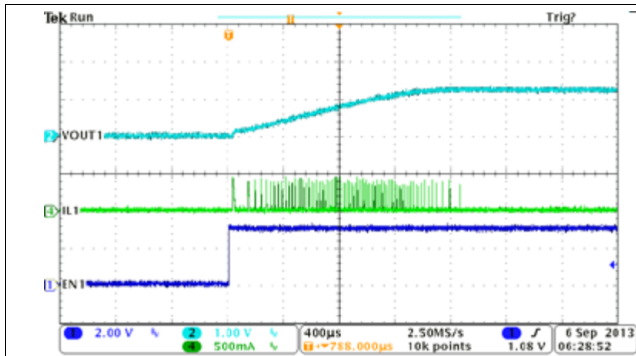

Figure 36. BUCK1, Soft-Start with No Load

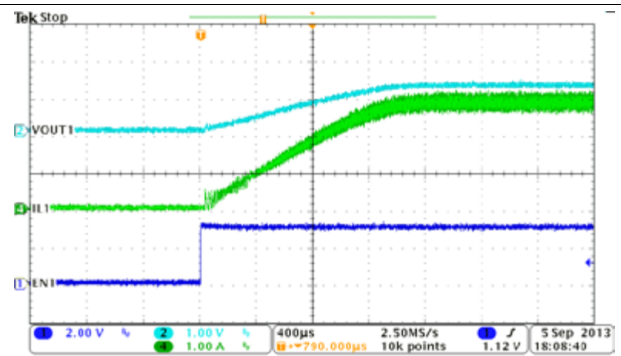

Figure 37. BUCK1, Soft-Start with Full Load

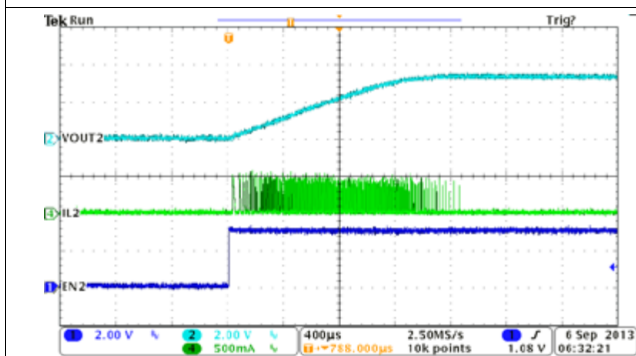

Figure 38. BUCK2, Soft-Start with No Load

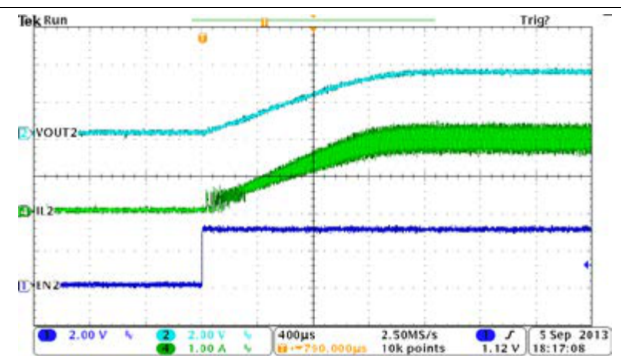

Figure 39. BUCK2, Soft-Start with Full Load

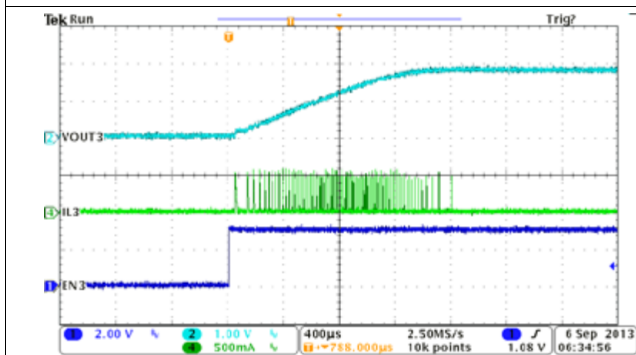

Figure 40. BUCK3, Soft-Start with No Load

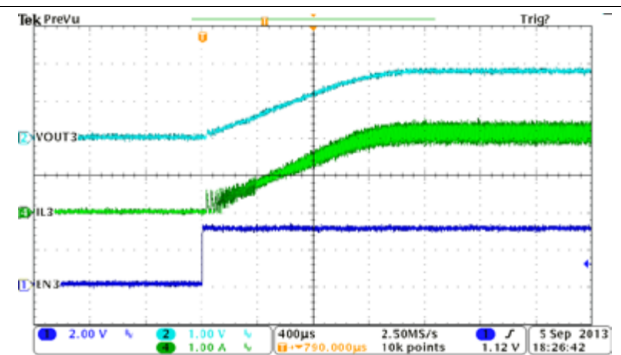

Figure 41. BUCK3, Soft-Start with Full Load

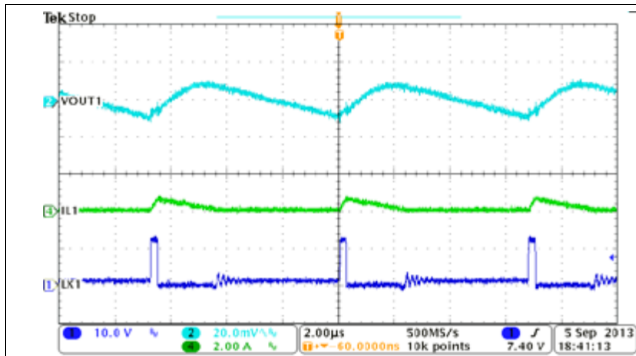

Figure 42. BUCK1, PSM Mode, Steady State Operation at Light Load

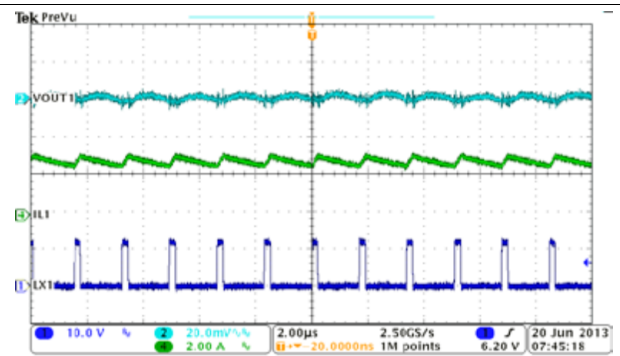

Figure 43. BUCK1, Steady State Operation with Full Load

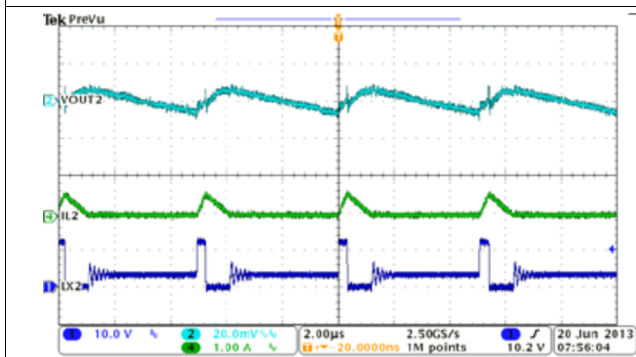

Figure 44. BUCK2, PSM Mode, Steady State Operation at Light Load

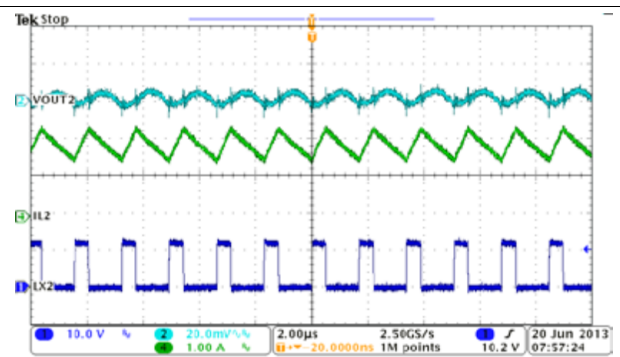

Figure 45. BUCK2, Steady State Operation with Full Load

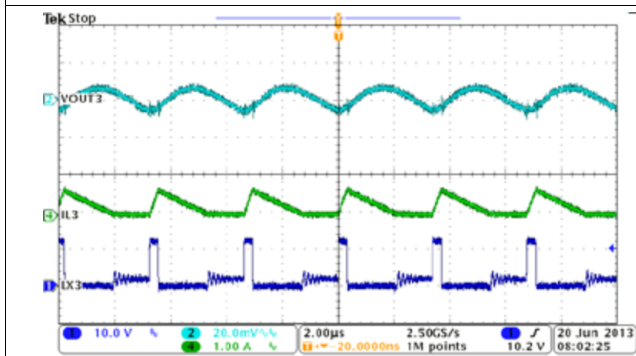

Figure 46. BUCK3, PSM Mode, Steady State Operation with Light Load

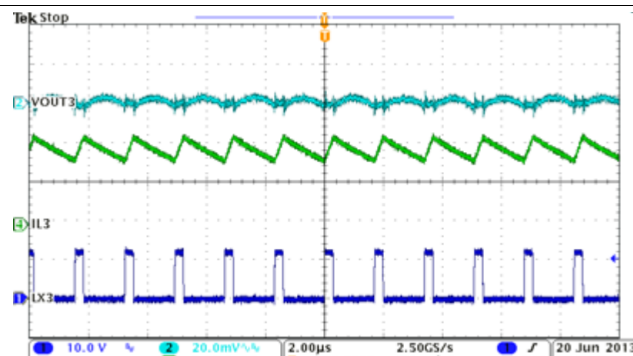

Figure 47. BUCK3, Steady State Operation with Full Load

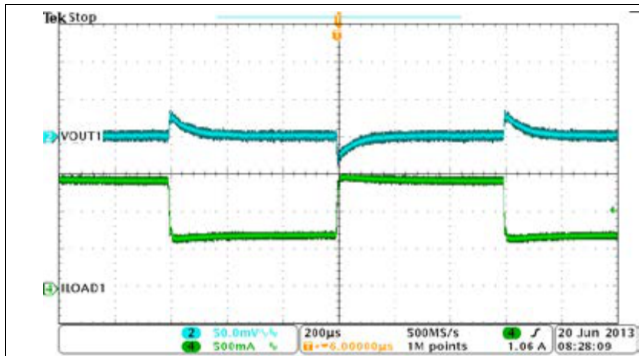

Figure 48. BUCK1, Load Transient, 0.75A to 1.5A SR=0.25A/µs

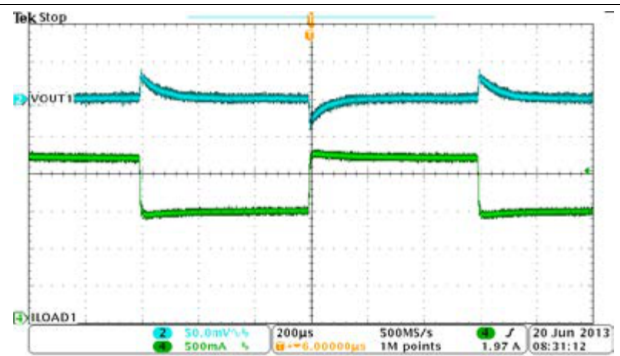

Figure 49. BUCK1, Load Transient, 1.5A to 2.25A SR=0.25A/µs

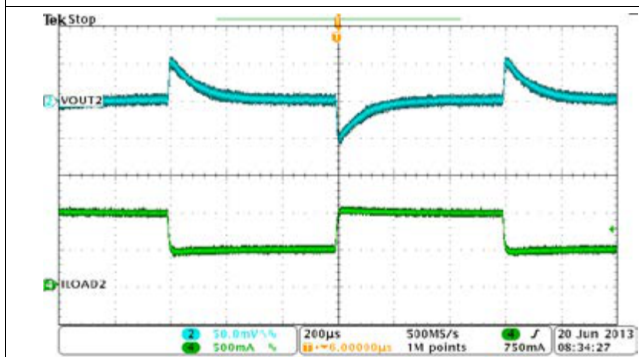

Figure 50. BUCK2, Load Transient, 0.5A to 1.0A SR=0.25A/µs

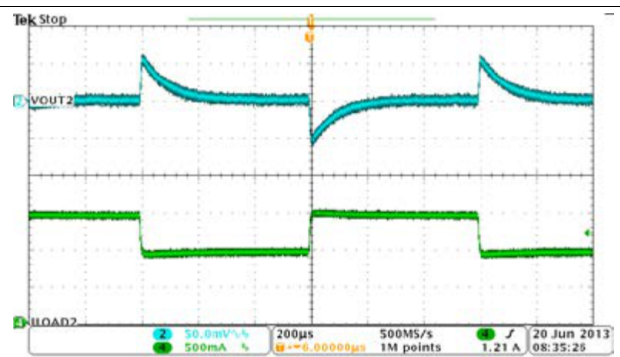

Figure 51. BUCK2, Load Transient, 1.0A to 1.5A SR=0.25A/µs

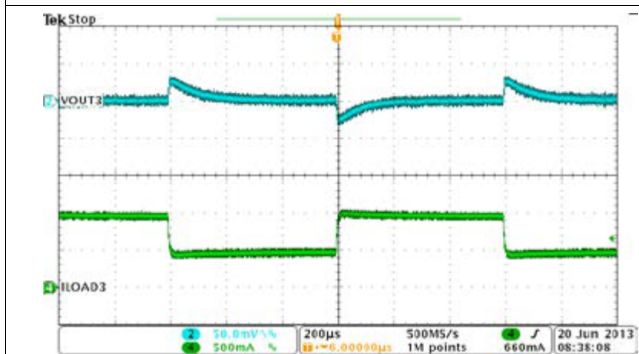

Figure 52. BUCK3, Load Transient, 0.5A to 1.0A SR=0.25A/µs

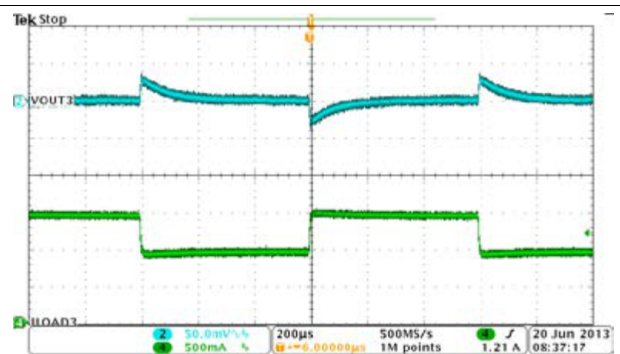

Figure 53. BUCK3, Load Transient, 1.0A to 1.5A SR=0.25A/µs

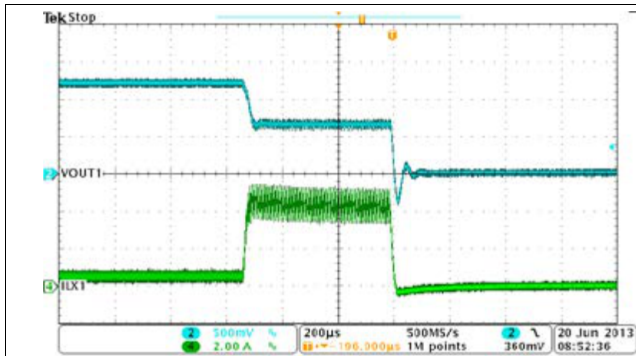

Figure 54. BUCK1, Over Current Protection

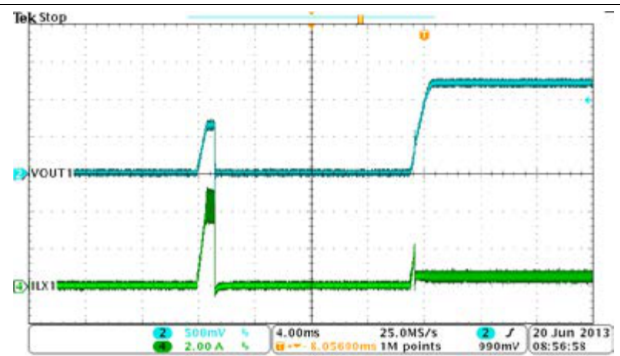

Figure 55. BUCK1, Hiccup and Recovery

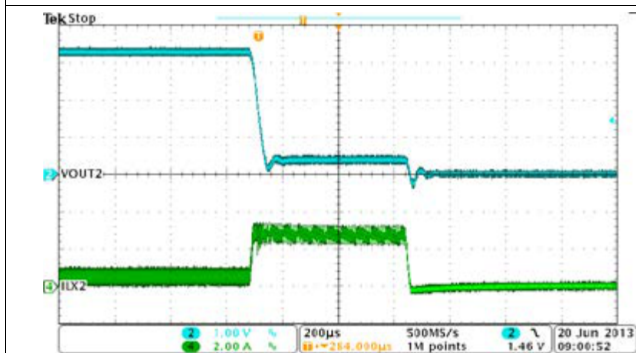

Figure 56. BUCK2, Over Current Protection

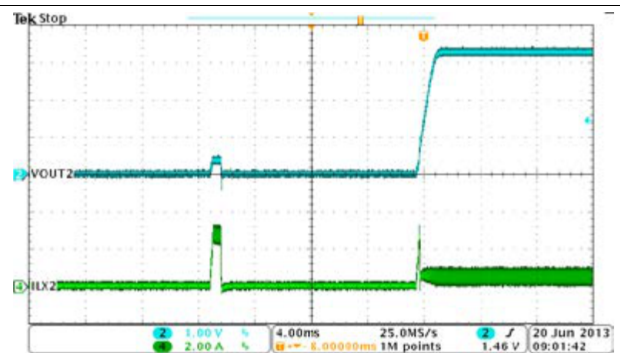

Figure 57. BUCK2, Hiccup and Recovery

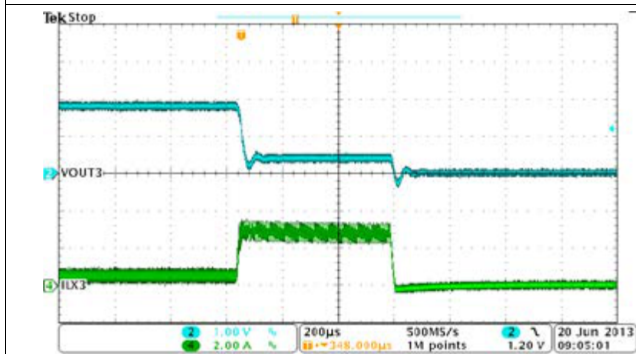

Figure 58. BUCK3, Over Current Protection

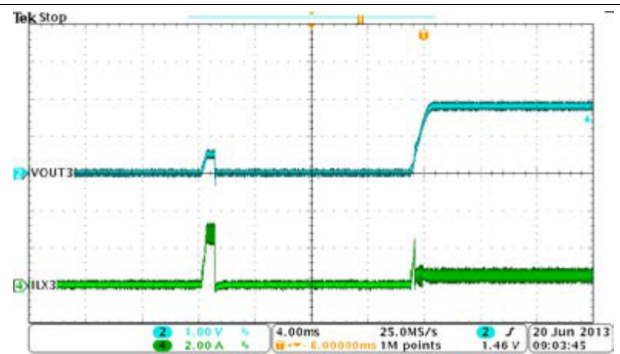

Figure 59. BUCK3, Hiccup and Recovery

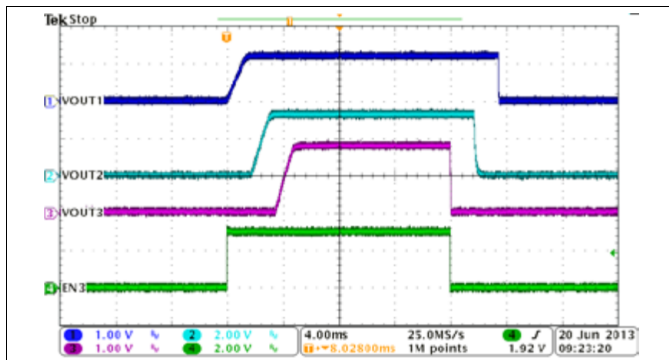

Figure 60. Automatic Power Sequencing, MODE=EN1=EN2=HIGH

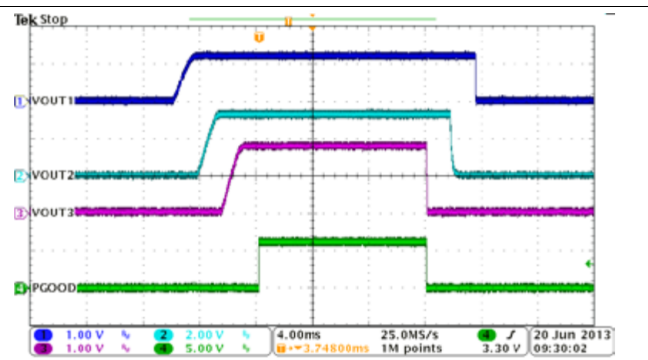

Figure 61. Automatic Power Sequencing, MODE=EN1=EN2=HIGH

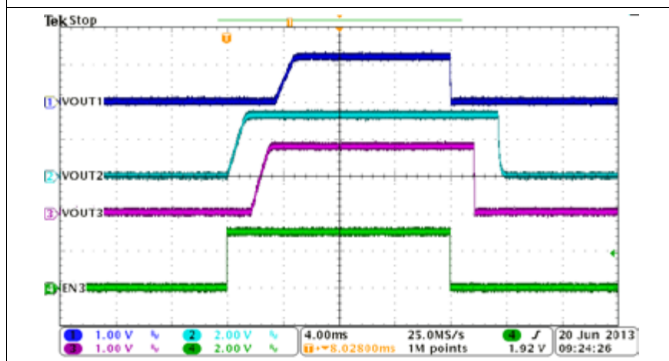

Figure 62. Automatic Power Sequencing, MODE=EN1=HIGH, EN2=LOW

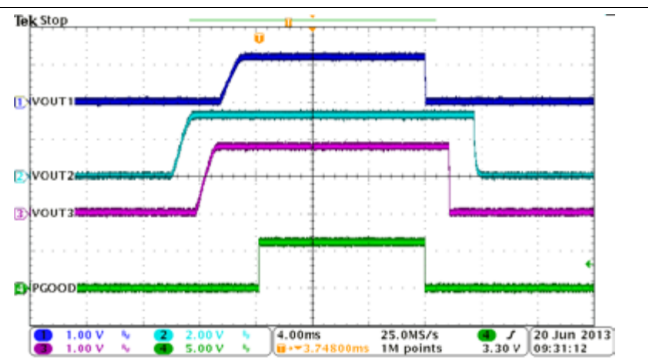

Figure 63. Automatic Power Sequencing, MODE=EN1=HIGH, EN2=LOW

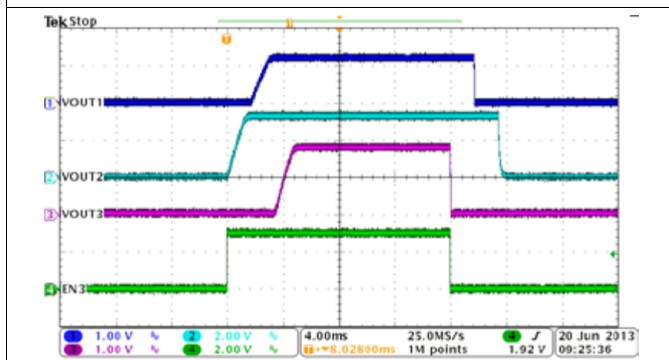

Figure 64. Automatic Power Sequencing, MODE=EN2=HIGH, EN1=LOW

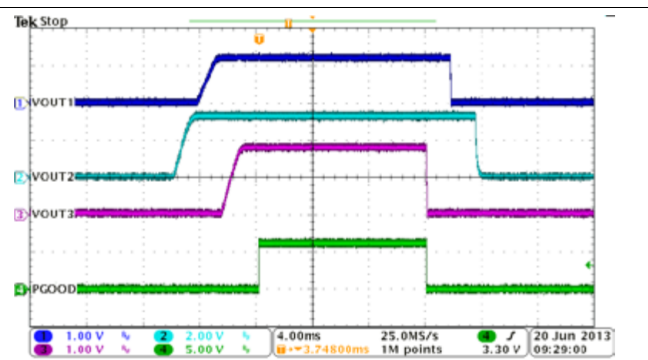

Figure 65. Automatic Power Sequencing, MODE=EN2=HIGH, EN1=LOW

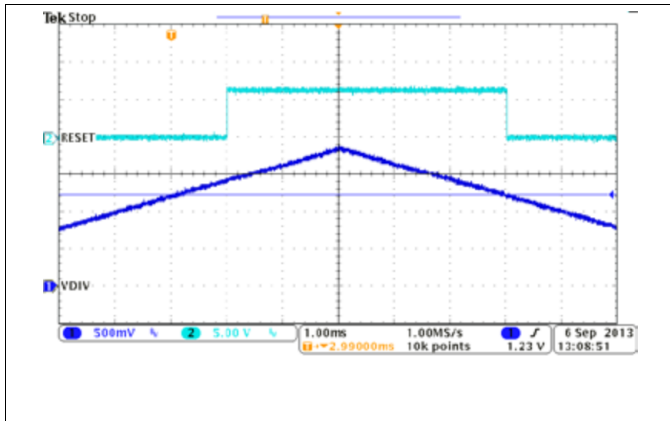

Figure 66. Trigger Voltage 1.23V, Reset vs VDIV

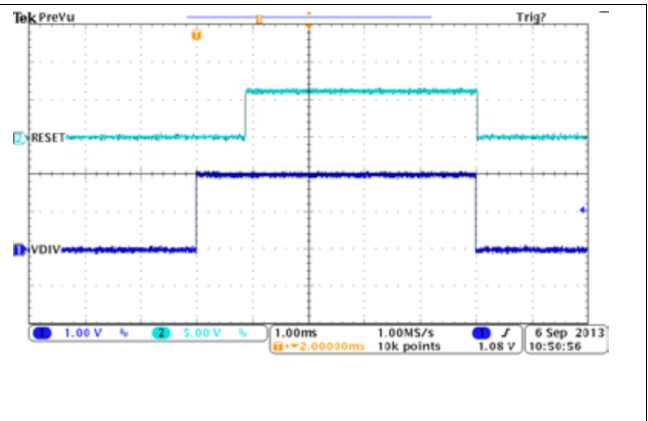

Figure 67. Deglitch Time, Reset vs VDIV

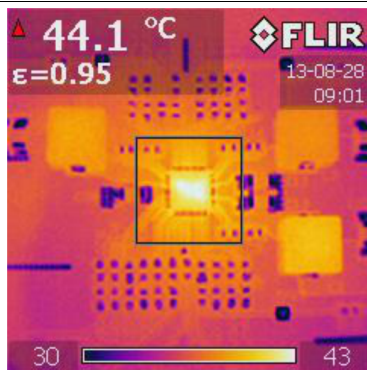

Figure 68. Thermal Signature of TPS65261EVM

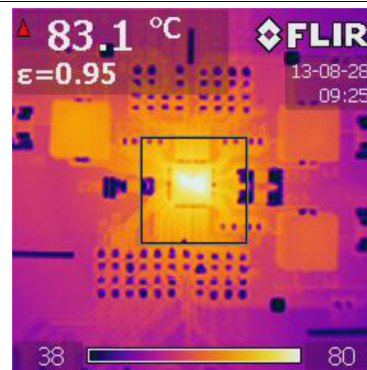

Figure 69. Thermal Signature of TPS65261EVM

10 Power Supply Recommendations

The devices are designed to operate from an input voltage supply range between 4.5 V and 18 V. This input power supply should be well regulated. If the input supply is located more than a few inches from the TPS65261 or TPS65261-1 converter additional bulk capacitance may be required in addition to the ceramic bypass capacitors. An electrolytic capacitor with a value of 47 μ F is a typical choice.

11 Layout

11.1 Layout Guidelines

The TPS65261, TPS65261-1 can be laid out on 2-layer PCB, illustrated in [Figure 70](#).

Layout is a critical portion of good power supply design. See [Figure 70](#) for a PCB layout example. The top contains the main power traces for PVIN, VOUT, and LX. Also on the top layer are connections for the remaining pins of the TPS65261, TPS65261-1 and a large top side area filled with ground. The top layer ground area should be connected to the bottom layer ground using vias at the input bypass capacitor, the output filter capacitor and directly under the TPS65261, TPS65261-1 device to provide a thermal path from the exposed thermal pad land to ground. The bottom layer acts as ground plane connecting analog ground and power ground.

For operation at full rated load, the top side ground area together with the bottom side ground plane must provide adequate heat dissipating area. There are several signals paths that conduct fast changing currents or voltages that can interact with stray inductance or parasitic capacitance to generate noise or degrade the power supplies performance. To help eliminate these problems, the PVIN pin should be bypassed to ground with a low ESR ceramic bypass capacitor with X5R or X7R dielectric. Care should be taken to minimize the loop area formed by the bypass capacitor connections, the PVIN pins and the ground connections. The VIN pin must also be bypassed to ground using a low ESR ceramic capacitor with X5R or X7R dielectric.

Since the LX connection is the switching node, the output inductor should be located close to the LX pins, and the area of the PCB conductor minimized to prevent excessive capacitive coupling. The output filter capacitor ground should use the same power ground trace as the PVIN input bypass capacitor. Try to minimize this conductor length while maintaining adequate width. The small signal components should be grounded to the analog ground path.

The FB and COMP pins are sensitive to noise so the resistors and capacitors should be located as close as possible to the IC and routed with minimal lengths of trace. The additional external components can be placed approximately as shown.

11.2 Layout Example

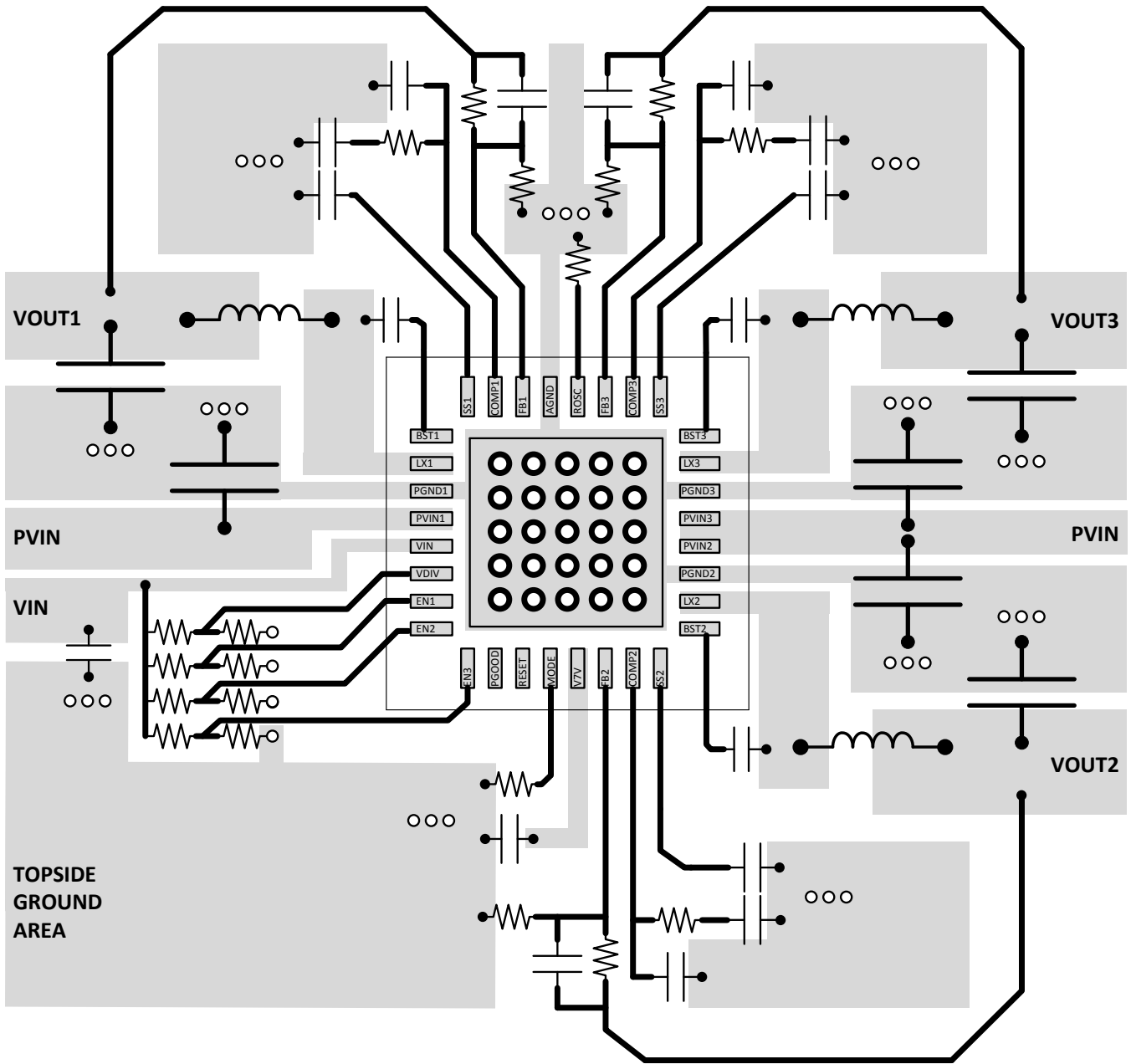

- 0.010 in. Diameter Thermal VIA to Ground Plane
- VIA to Ground Plane

Figure 70. PCB Layout

12 器件和文档支持

12.1 文档支持

12.1.1 相关器件

器件型号	说明	备注
TPS65262	4.5V 至 18V 三路降压，具有双路可调 LDO	三路降压 3A/1A/1A 输出电流，双路 LDO 100mA/200mA 输出电流，自动电源排序
TPS65263	4.5V 至 18V 三路降压，具有 I2C 接口	三路降压 3A/2A/2A 输出电流，I2C 控制的动态电压调节 (DVS)
TPS65651-1/2/3	4.5V 至 18V 三路降压，具有多种 PGOOD 去毛刺脉冲时间	三路降压 3A/2A/2A 输出电流，支持 1s、32ms 和 256ms 三种 PGOOD 去毛刺脉冲时间，可通过外部电阻调节限流设置
TPS65287	4.5V 至 18V 三路降压，具有电源开关和按钮控制	三路降压 3A/2A/2A 输出电流，最高 2.1A USB 电源，可通过外部电阻进行过流设置，可通过按钮控制智能系统上电/掉电操作
TPS65288	4.5V 至 18V 三路降压，具有双电源开关	三路降压 3A/2A/2A 输出电流，2 个 USB 电源开关，限流典型值为 1.2A（出厂时提供 0.8/1.0/1.4/1.6/1.8/2.0/2.2A 多种电流供选择调整）

12.2 相关链接

以下表格列出了快速访问链接。范围包括技术文档、支持与社区资源、工具和软件，并且可以快速访问样片或购买链接。

表 4. 相关链接

器件	产品文件夹	样片与购买	技术文档	工具与软件	支持与社区
TPS65261	请单击此处	请单击此处	请单击此处	请单击此处	请单击此处
TPS65261-1	请单击此处	请单击此处	请单击此处	请单击此处	请单击此处

12.3 商标

All trademarks are the property of their respective owners.

12.4 静电放电警告



这些装置包含有限的内置 ESD 保护。存储或装卸时，应将导线一起截短或将装置放置于导电泡棉中，以防止 MOS 门极遭受静电损伤。

12.5 术语表

[SLYZ022](#) — TI 术语表。

这份术语表列出并解释术语、首字母缩略词和定义。

13 机械封装和可订购信息

以下页中包括机械封装和可订购信息。这些信息是针对指定器件可提供的最新数据。这些数据会在无通知且不对本文档进行修订的情况下发生改变。欲获得该数据表的浏览器版本，请查阅左侧的导航栏。

重要声明

德州仪器(TI)及其下属子公司有权根据 JESD46 最新标准,对所提供的产品和服务进行更正、修改、增强、改进或其它更改,并有权根据 JESD48 最新标准中止提供任何产品和服务。客户在下订单前应获取最新的相关信息,并验证这些信息是否完整且是最新的。所有产品的销售都遵循在订单确认时所提供的TI 销售条款与条件。

TI 保证其所销售的组件的性能符合产品销售时 TI 半导体产品销售条件与条款的适用规范。仅在 TI 保证的范围内,且 TI 认为有必要时才会使用测试或其它质量控制技术。除非适用法律做出了硬性规定,否则没有必要对每种组件的所有参数进行测试。

TI 对应用帮助或客户产品设计不承担任何义务。客户应对其使用 TI 组件的产品和应用自行负责。为尽量减小与客户产品和应用相关的风险,客户应提供充分的设计与操作安全措施。

TI 不对任何 TI 专利权、版权、屏蔽作品权或其它与使用了 TI 组件或服务的组合设备、机器或流程相关的 TI 知识产权中授予的直接或隐含权限作出任何保证或解释。TI 所发布的与第三方产品或服务有关的信息,不能构成从 TI 获得使用这些产品或服务的许可、授权、或认可。使用此类信息可能需要获得第三方的专利权或其它知识产权方面的许可,或是 TI 的专利权或其它知识产权方面的许可。

对于 TI 的产品手册或数据表中 TI 信息的重要部分,仅在没有对内容进行任何篡改且带有相关授权、条件、限制和声明的情况下才允许进行复制。TI 对此类篡改过的文件不承担任何责任或义务。复制第三方的信息可能需要服从额外的限制条件。

在转售 TI 组件或服务时,如果对该组件或服务参数的陈述与 TI 标明的参数相比存在差异或虚假成分,则会失去相关 TI 组件或服务的所有明示或暗示授权,且这是不正当的、欺诈性商业行为。TI 对任何此类虚假陈述均不承担任何责任或义务。

客户认可并同意,尽管任何应用相关信息或支持仍可能由 TI 提供,但他们将独立负责满足与其产品及其在应用中使用的 TI 产品相关的所有法律、法规和安全相关要求。客户声明并同意,他们具备制定与实施安全措施所需的全部专业技术和知识,可预见故障的危险后果、监测故障及其后果、降低有可能造成人身伤害的故障的发生机率并采取适当的补救措施。客户将全额赔偿因在此类安全关键应用中使用任何 TI 组件而对 TI 及其代理造成的任何损失。

在某些场合中,为了推进安全相关应用有可能对 TI 组件进行特别的促销。TI 的目标是利用此类组件帮助客户设计和创立其特有的可满足适用的功能安全性标准和要求的终端产品解决方案。尽管如此,此类组件仍然服从这些条款。

TI 组件未获得用于 FDA Class III (或类似的生命攸关医疗设备)的授权许可,除非各方授权官员已经达成了专门管控此类使用的特别协议。

只有那些 TI 特别注明属于军用等级或“增强型塑料”的 TI 组件才是设计或专门用于军事/航空应用或环境的。购买者认可并同意,对并非指定面向军事或航空航天用途的 TI 组件进行军事或航空航天方面的应用,其风险由客户单独承担,并且由客户独立负责满足与此类使用相关的所有法律和法规要求。

TI 已明确指定符合 ISO/TS16949 要求的产品,这些产品主要用于汽车。在任何情况下,因使用非指定产品而无法达到 ISO/TS16949 要求, TI 不承担任何责任。

	产品		应用
数字音频	www.ti.com.cn/audio	通信与电信	www.ti.com.cn/telecom
放大器和线性器件	www.ti.com.cn/amplifiers	计算机及周边	www.ti.com.cn/computer
数据转换器	www.ti.com.cn/dataconverters	消费电子	www.ti.com.cn/consumer-apps
DLP® 产品	www.dlp.com	能源	www.ti.com.cn/energy
DSP - 数字信号处理器	www.ti.com.cn/dsp	工业应用	www.ti.com.cn/industrial
时钟和计时器	www.ti.com.cn/clockandtimers	医疗电子	www.ti.com.cn/medical
接口	www.ti.com.cn/interface	安防应用	www.ti.com.cn/security
逻辑	www.ti.com.cn/logic	汽车电子	www.ti.com.cn/automotive
电源管理	www.ti.com.cn/power	视频和影像	www.ti.com.cn/video
微控制器 (MCU)	www.ti.com.cn/microcontrollers		
RFID 系统	www.ti.com.cn/rfidsys		
OMAP应用处理器	www.ti.com/omap		
无线连通性	www.ti.com.cn/wirelessconnectivity	德州仪器在线技术支持社区	www.deyisupport.com

邮寄地址: 上海市浦东新区世纪大道1568号, 中建大厦32楼邮政编码: 200122
Copyright © 2015, 德州仪器半导体技术(上海)有限公司

PACKAGING INFORMATION

Orderable Device	Status (1)	Package Type	Package Drawing	Pins	Package Qty	Eco Plan (2)	Lead finish/ Ball material (6)	MSL Peak Temp (3)	Op Temp (°C)	Device Marking (4/5)	Samples
TPS65261-1RHBR	ACTIVE	VQFN	RHB	32	3000	RoHS & Green	NIPDAU	Level-2-260C-1 YEAR	-40 to 85	TPS 65261-1	Samples
TPS65261-1RHBT	ACTIVE	VQFN	RHB	32	250	RoHS & Green	NIPDAU	Level-2-260C-1 YEAR	-40 to 85	TPS 65261-1	Samples
TPS65261RHBR	ACTIVE	VQFN	RHB	32	3000	RoHS & Green	NIPDAU	Level-2-260C-1 YEAR	-40 to 85	TPS 65261	Samples
TPS65261RHBT	ACTIVE	VQFN	RHB	32	250	RoHS & Green	NIPDAU	Level-2-260C-1 YEAR	-40 to 85	TPS 65261	Samples

(1) The marketing status values are defined as follows:

ACTIVE: Product device recommended for new designs.

LIFEBUY: TI has announced that the device will be discontinued, and a lifetime-buy period is in effect.

NRND: Not recommended for new designs. Device is in production to support existing customers, but TI does not recommend using this part in a new design.

PREVIEW: Device has been announced but is not in production. Samples may or may not be available.

OBSELETE: TI has discontinued the production of the device.

(2) **RoHS:** TI defines "RoHS" to mean semiconductor products that are compliant with the current EU RoHS requirements for all 10 RoHS substances, including the requirement that RoHS substance do not exceed 0.1% by weight in homogeneous materials. Where designed to be soldered at high temperatures, "RoHS" products are suitable for use in specified lead-free processes. TI may reference these types of products as "Pb-Free".

RoHS Exempt: TI defines "RoHS Exempt" to mean products that contain lead but are compliant with EU RoHS pursuant to a specific EU RoHS exemption.

Green: TI defines "Green" to mean the content of Chlorine (Cl) and Bromine (Br) based flame retardants meet JS709B low halogen requirements of <=1000ppm threshold. Antimony trioxide based flame retardants must also meet the <=1000ppm threshold requirement.

(3) MSL, Peak Temp. - The Moisture Sensitivity Level rating according to the JEDEC industry standard classifications, and peak solder temperature.

(4) There may be additional marking, which relates to the logo, the lot trace code information, or the environmental category on the device.

(5) Multiple Device Markings will be inside parentheses. Only one Device Marking contained in parentheses and separated by a "~" will appear on a device. If a line is indented then it is a continuation of the previous line and the two combined represent the entire Device Marking for that device.

(6) Lead finish/Ball material - Orderable Devices may have multiple material finish options. Finish options are separated by a vertical ruled line. Lead finish/Ball material values may wrap to two lines if the finish value exceeds the maximum column width.

Important Information and Disclaimer:The information provided on this page represents TI's knowledge and belief as of the date that it is provided. TI bases its knowledge and belief on information provided by third parties, and makes no representation or warranty as to the accuracy of such information. Efforts are underway to better integrate information from third parties. TI has taken and

continues to take reasonable steps to provide representative and accurate information but may not have conducted destructive testing or chemical analysis on incoming materials and chemicals. TI and TI suppliers consider certain information to be proprietary, and thus CAS numbers and other limited information may not be available for release.

In no event shall TI's liability arising out of such information exceed the total purchase price of the TI part(s) at issue in this document sold by TI to Customer on an annual basis.

TAPE AND REEL INFORMATION

QUADRANT ASSIGNMENTS FOR PIN 1 ORIENTATION IN TAPE

*All dimensions are nominal

Device	Package Type	Package Drawing	Pins	SPQ	Reel Diameter (mm)	Reel Width W1 (mm)	A0 (mm)	B0 (mm)	K0 (mm)	P1 (mm)	W (mm)	Pin1 Quadrant
TPS65261-1RHBR	VQFN	RHB	32	3000	330.0	12.4	5.3	5.3	1.1	8.0	12.0	Q2
TPS65261-1RHBR	VQFN	RHB	32	3000	330.0	12.4	5.25	5.25	1.1	8.0	12.0	Q2
TPS65261-1RHBT	VQFN	RHB	32	250	180.0	12.5	5.25	5.25	1.1	8.0	12.0	Q2
TPS65261-1RHBT	VQFN	RHB	32	250	180.0	12.4	5.3	5.3	1.1	8.0	12.0	Q2
TPS65261RHBR	VQFN	RHB	32	3000	330.0	12.4	5.3	5.3	1.1	8.0	12.0	Q2
TPS65261RHBR	VQFN	RHB	32	3000	330.0	12.4	5.25	5.25	1.1	8.0	12.0	Q2
TPS65261RHBT	VQFN	RHB	32	250	180.0	12.5	5.25	5.25	1.1	8.0	12.0	Q2
TPS65261RHBT	VQFN	RHB	32	250	180.0	12.4	5.3	5.3	1.1	8.0	12.0	Q2

TAPE AND REEL BOX DIMENSIONS

*All dimensions are nominal

Device	Package Type	Package Drawing	Pins	SPQ	Length (mm)	Width (mm)	Height (mm)
TPS65261-1RHBR	VQFN	RHB	32	3000	367.0	367.0	35.0
TPS65261-1RHBR	VQFN	RHB	32	3000	338.0	355.0	50.0
TPS65261-1RHBT	VQFN	RHB	32	250	205.0	200.0	33.0
TPS65261-1RHBT	VQFN	RHB	32	250	210.0	185.0	35.0
TPS65261RHBR	VQFN	RHB	32	3000	367.0	367.0	35.0
TPS65261RHBR	VQFN	RHB	32	3000	338.0	355.0	50.0
TPS65261RHBT	VQFN	RHB	32	250	338.0	355.0	50.0
TPS65261RHBT	VQFN	RHB	32	250	210.0	185.0	35.0

GENERIC PACKAGE VIEW

RHB 32

VQFN - 1 mm max height

5 x 5, 0.5 mm pitch

PLASTIC QUAD FLATPACK - NO LEAD

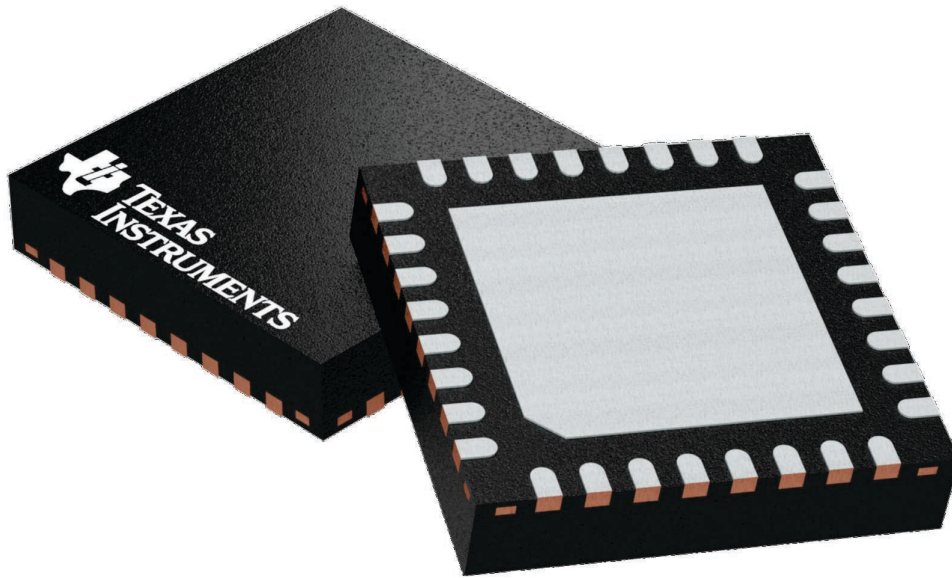

Images above are just a representation of the package family, actual package may vary.
Refer to the product data sheet for package details.

4224745/A

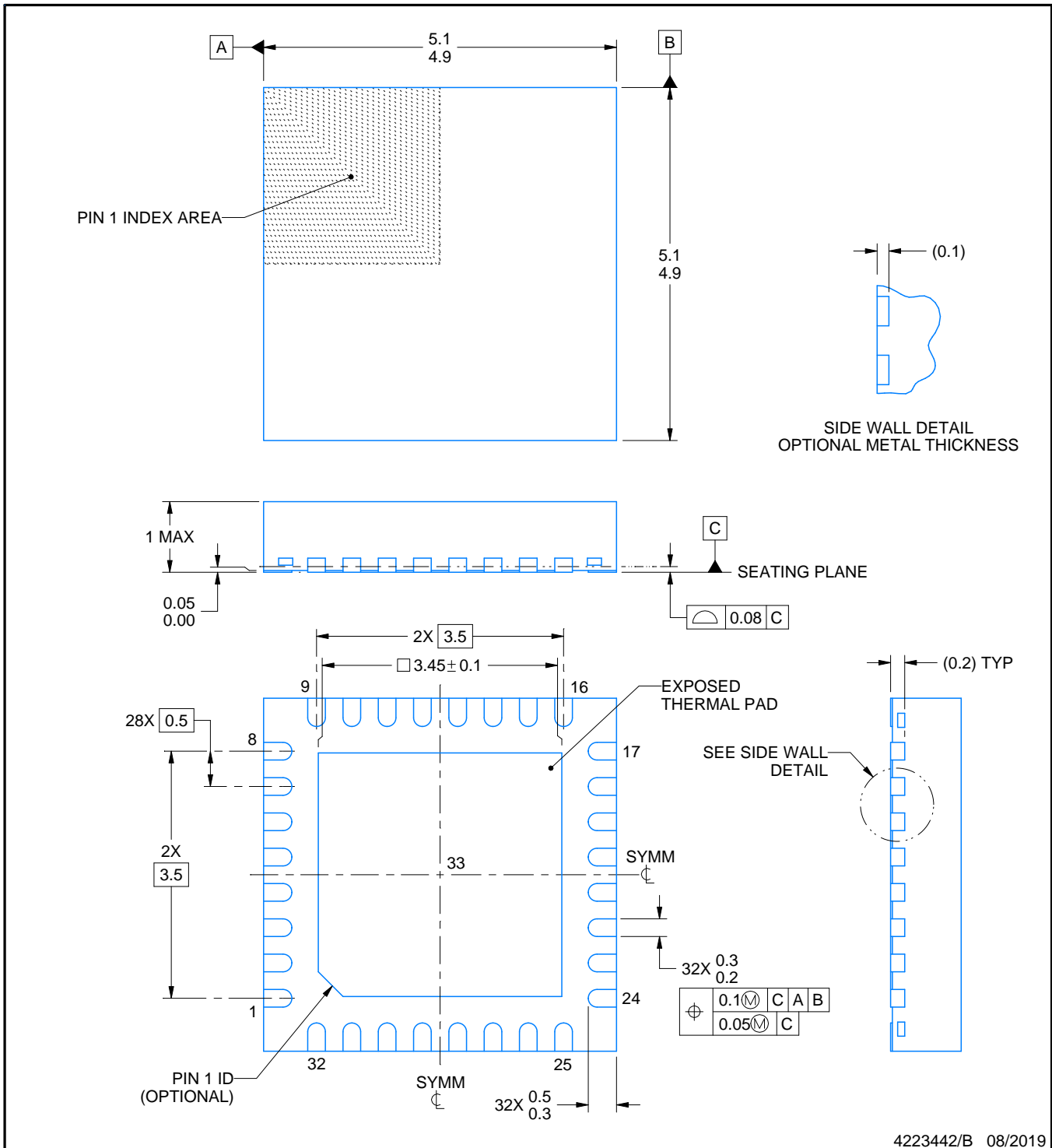
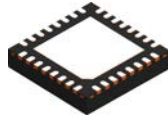

4223442/B 08/2019

NOTES:

1. All linear dimensions are in millimeters. Any dimensions in parenthesis are for reference only. Dimensioning and tolerancing per ASME Y14.5M.
2. This drawing is subject to change without notice.
3. The package thermal pad must be soldered to the printed circuit board for thermal and mechanical performance.

EXAMPLE BOARD LAYOUT

RHB0032E

VQFN - 1 mm max height

PLASTIC QUAD FLATPACK - NO LEAD

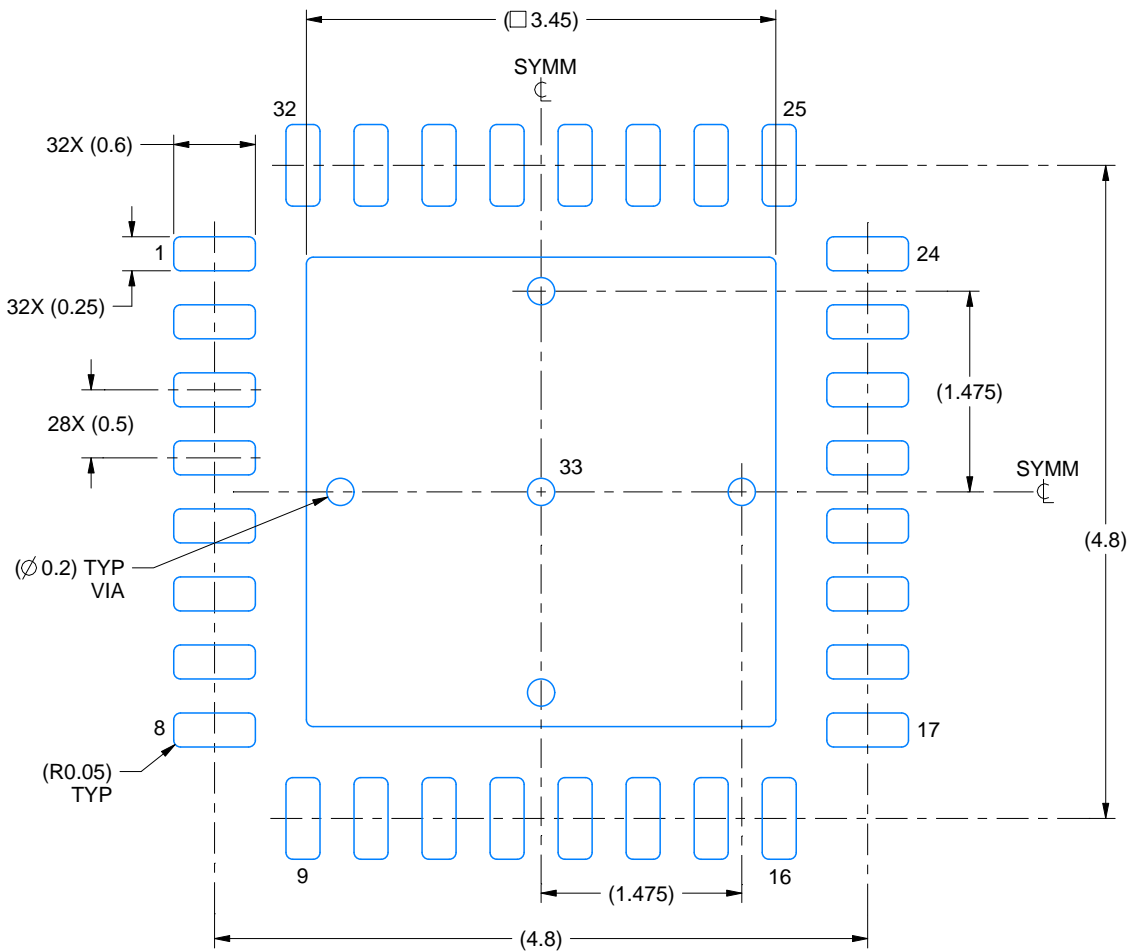

LAND PATTERN EXAMPLE
SCALE:18X

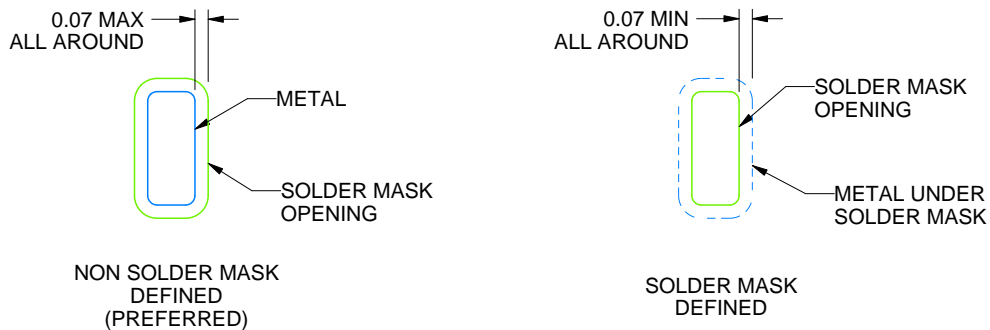

SOLDER MASK DETAILS

4223442/B 08/2019

NOTES: (continued)

- This package is designed to be soldered to a thermal pad on the board. For more information, see Texas Instruments literature number SLUA271 (www.ti.com/lit/sluea271).
- Vias are optional depending on application, refer to device data sheet. If any vias are implemented, refer to their locations shown on this view. It is recommended that vias under paste be filled, plugged or tented.

EXAMPLE STENCIL DESIGN

RHB0032E

VQFN - 1 mm max height

PLASTIC QUAD FLATPACK - NO LEAD

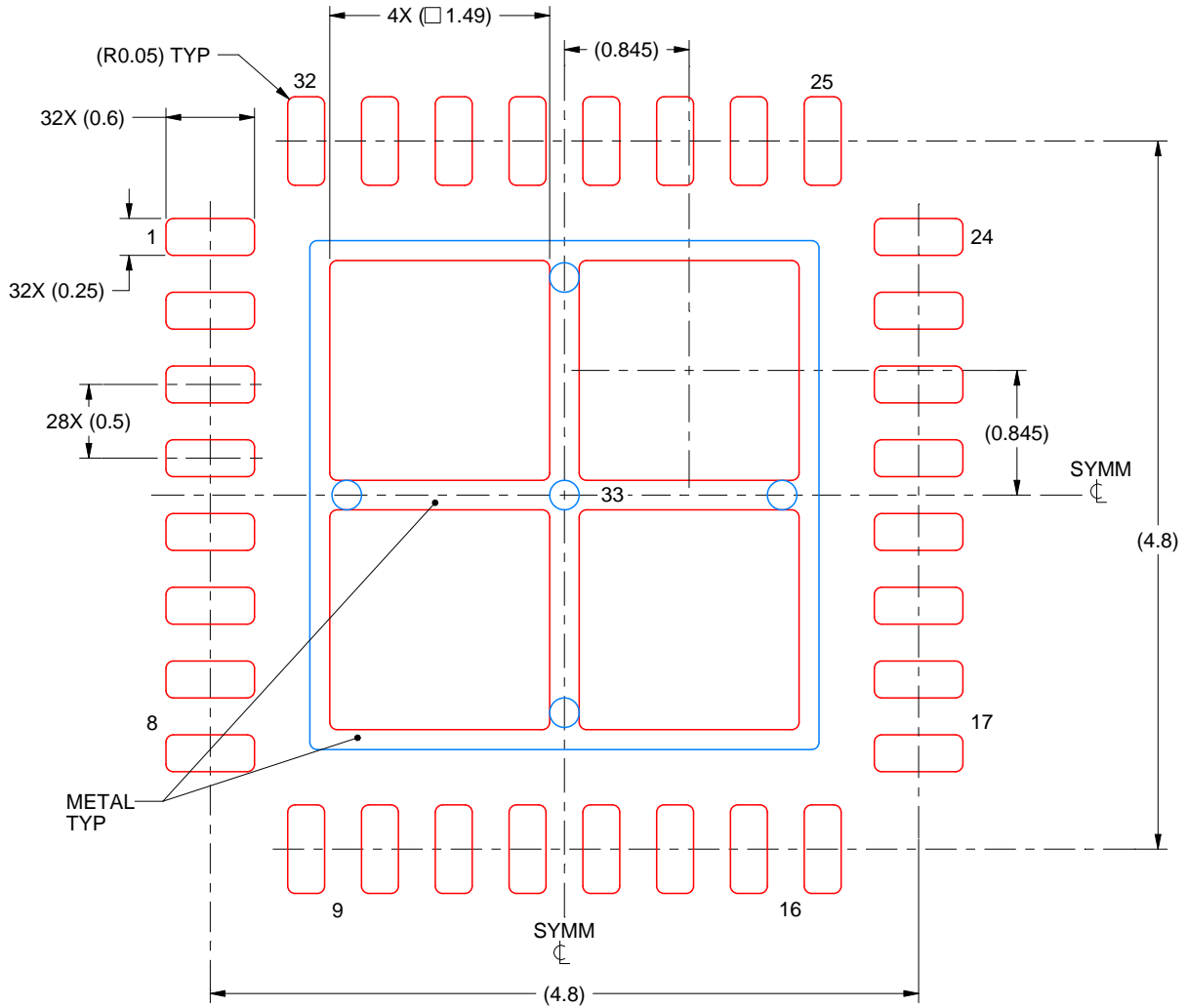

SOLDER PASTE EXAMPLE
 BASED ON 0.125 mm THICK STENCIL

EXPOSED PAD 33:
 75% PRINTED SOLDER COVERAGE BY AREA UNDER PACKAGE
 SCALE:20X

4223442/B 08/2019

NOTES: (continued)

6. Laser cutting apertures with trapezoidal walls and rounded corners may offer better paste release. IPC-7525 may have alternate design recommendations.

重要声明和免责声明

TI 均以“原样”提供技术性及其可靠性数据（包括数据表）、设计资源（包括参考设计）、应用或其他设计建议、网络工具、安全信息和其他资源，不保证其中不含任何瑕疵，且不做任何明示或暗示的担保，包括但不限于对适销性、适合某特定用途或不侵犯任何第三方知识产权的暗示担保。

所述资源可供专业开发人员应用TI 产品进行设计使用。您将对以下行为独自承担全部责任：(1) 针对您的应用选择合适的TI 产品；(2) 设计、验证并测试您的应用；(3) 确保您的应用满足相应标准以及任何其他安全、安保或其他要求。所述资源如有变更，恕不另行通知。TI 对您使用所述资源的授权仅限于开发资源所涉及TI 产品的相关应用。除此之外不得复制或展示所述资源，也不提供其它TI 或任何第三方的知识产权授权许可。如因使用所述资源而产生任何索赔、赔偿、成本、损失及债务等，TI 对此概不负责，并且您须赔偿由此对TI 及其代表造成的损害。

TI 所提供产品均受TI 的销售条款 (<http://www.ti.com.cn/zh-cn/legal/termsofsale.html>) 以及ti.com.cn 上或随附TI 产品提供的其他可适用条款的约束。TI 提供所述资源并不扩展或以其他方式更改TI 针对TI 产品所发布的可适用的担保范围或担保免责声明。

邮寄地址：上海市浦东新区世纪大道 1568 号中建大厦 32 楼，邮政编码：200122

Copyright © 2020 德州仪器半导体技术（上海）有限公司