

# TPS22968-Q1 5.5V、4A、27mΩ 导通电阻负载开关

## 1 特性

- 集成双通道负载开关
  - 符合汽车应用要求:
    - 器件温度 1 级 (工作环境温度范围:  $-40^{\circ}\text{C}$  至  $125^{\circ}\text{C}$ )
  - 输入电压范围: 0.8V 至 5.5V
  - VBIAS 电压范围: 2.5V 至 5.5V
  - 导通电阻
    - $V_{\text{IN}} = 5\text{V}$  ( $V_{\text{BIAS}} = 5\text{V}$ ) 时,  $R_{\text{ON}} = 29\text{m}\Omega$
    - $V_{\text{IN}} = 3.3\text{V}$  ( $V_{\text{BIAS}} = 5\text{V}$ ) 时,  $R_{\text{ON}} = 27\text{m}\Omega$
    - $V_{\text{IN}} = 1.8\text{V}$  ( $V_{\text{BIAS}} = 5\text{V}$ ) 时,  $R_{\text{ON}} = 26\text{m}\Omega$
  - 每通道最大 4A 持续开关电流
  - 低静态电流
    - $V_{\text{BIAS}} = 5\text{V}$  时为  $58\mu\text{A}$  (双通道)
  - 低控制输入阈值支持使用 1.2/1.8/2.5/3.3V 逻辑器件
  - 可通过 CT 引脚<sup>(1)</sup> 配置上升时间
  - 快速输出放电 (QOD)<sup>(2)</sup>
  - 10 引脚晶圆级小外形无引线 (WSON) 封装, 具有可湿性侧面
  - 静电放电 (ESD) 性能经测试符合 JEDEC STD 标准
    - $\pm 2\text{kV}$  人体模型 (HBM) 和  $\pm 1\text{kV}$  器件充电模型 (CDM)
  - 锁断性能达 100mA, 符合 JESD 78 II 类规范的要求
  - 通用输入输出 (GPIO) 使能 - 高电平有效
- (1) 有关 CT 值与上升时间的关系, 请参见 [Adjustable Rise Time](#)
- (2) 此特性通过一个  $270\Omega$  电阻将开关的输出放电至接地 (GND), 从而防止输出悬空。

## 2 应用

- 汽车电子产品
- 信息娱乐
- 仪表盘
- ADAS

## 3 说明

TPS22968-Q1 是一款具有可配置上升时间的小型双通道负载开关。此器件包含两个可在 0.8 至 5.5V 输入电压范围内运行的 N 通道 MOSFET, 并且每通道可支持最大 4A 的持续电流。每个开关可由一个打开/关闭输入 (ON1 和 ON2) 独立控制, 此输入可与低压控制信号直接对接。TPS22968-Q1 包含一个  $270\Omega$  片上负载电阻, 用于在此开关被关闭时进行快速输出放电。

TPS22968-Q1 采用节省空间的小型封装 (DMG), 并且具有可湿性侧面和集成散热焊盘。可湿性侧面支持目视焊接检查。器件在自然通风环境下的额定运行温度范围为  $40^{\circ}\text{C}$  至  $125^{\circ}\text{C}$ 。

器件信息<sup>(1)</sup>

器件型号	封装	封装尺寸 (标称值)
TPS22968-Q1	WSON (10)	2.00mm x 3.00mm

(1) 要了解所有可用封装, 请见数据表末尾的可订购产品附录。

典型应用电路原理图

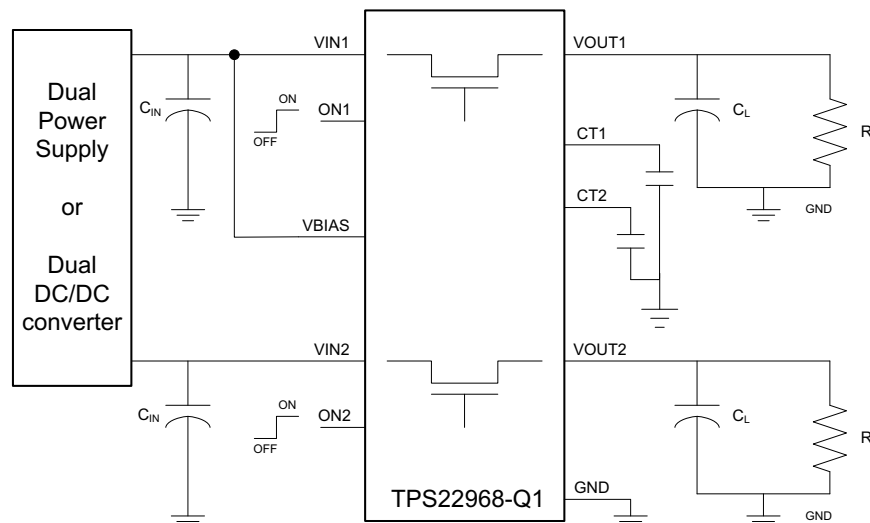

## 目录

<b>1 特性</b> ..... 1 <b>2 应用</b> ..... 1 <b>3 说明</b> ..... 1 <b>4 修订历史记录</b> ..... 2 <b>5 Pin Configuration and Functions</b> ..... 3 <b>6 Specifications</b> ..... 4 6.1 Absolute Maximum Ratings ..... 4 6.2 ESD Ratings ..... 4 6.3 Recommended Operating Conditions ..... 4 6.4 Thermal Information ..... 5 6.5 Electrical Characteristics ( $V_{BIAS} = 5\text{ V}$ ) ..... 5 6.6 Electrical Characteristics ( $V_{BIAS} = 3.3\text{ V}$ ) ..... 6 6.7 Electrical Characteristics ( $V_{BIAS} = 2.5\text{ V}$ ) ..... 7 6.8 Switching Characteristics ..... 8 6.9 Typical DC Characteristics ..... 9 6.10 Typical AC Characteristics ..... 11 <b>7 Parameter Measurement Information</b> ..... 14 <b>8 Detailed Description</b> ..... 15	8.1 Overview ..... 15 8.2 Functional Block Diagram ..... 15 8.3 Feature Description ..... 16 8.4 Device Functional Modes ..... 16 <b>9 Application and Implementation</b> ..... 17 9.1 Application Information ..... 17 9.2 Typical Application ..... 20 <b>10 Power Supply Recommendations</b> ..... 22 <b>11 Layout</b> ..... 22 11.1 Layout Guidelines ..... 22 11.2 Layout Example ..... 23 11.3 Thermal Considerations ..... 24 <b>12 器件和文档支持</b> ..... 25 12.1 商标 ..... 25 12.2 静电放电警告 ..... 25 12.3 术语表 ..... 25 <b>13 机械封装和可订购信息</b> ..... 25
---	---

## 4 修订历史记录

### Changes from Original (November 2014) to Revision A

Page

<ul style="list-style-type: none"> <li>• 已将器件状态更改为量产数据 ..... 1</li> </ul>	1
---	---

## 5 Pin Configuration and Functions

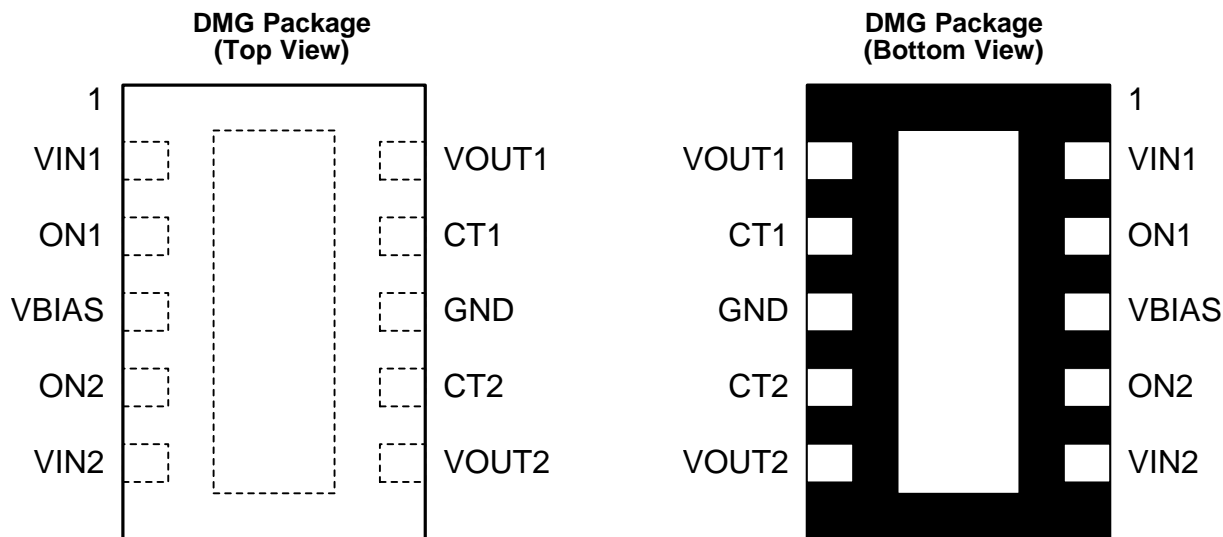

### Pin Functions

PIN		I/O	DESCRIPTION
NAME	NO.		
VIN1	1	I	Switch 1 input. Bypass this input with a ceramic capacitor to GND.
ON1	2	I	Active-high switch 1 control input. Do not leave floating.
VBIAS	3	I	Bias voltage. Power supply to the device. Recommended voltage range for this pin is 2.5 to 5.5 V. See <a href="#">VIN and VBIAS Voltage Range</a> .
ON2	4	I	Active-high switch 2 control input. Do not leave floating.
VIN2	5	I	Switch 2 input. Bypass this input with a ceramic capacitor to GND.
VOUT2	6	O	Switch 2 output
CT2	7	O	Switch 2 slew rate control. Can be left floating.
GND	8	—	Ground
CT1	9	O	Switch 1 slew rate control. Can be left floating.
VOUT1	10	O	Switch 1 output
Thermal Pad	—	—	Thermal pad (exposed center pad) to alleviate thermal stress. Tie to GND. See <a href="#">Layout Guidelines</a> .

## 6 Specifications

### 6.1 Absolute Maximum Ratings

Over operating free-air temperature (unless otherwise noted)<sup>(1)</sup> <sup>(2)</sup>

		MIN	MAX	UNIT
V <sub>IN1,2</sub>	Input voltage	-0.3	6	V
V <sub>BIAS</sub>	Bias voltage	-0.3	6	V
V <sub>OUT1,2</sub>	Output voltage	-0.3	6	V
V <sub>ON1,2</sub>	ON voltage	-0.3	6	V
I <sub>MAX</sub>	Maximum continuous switch current per channel, T <sub>A</sub> = 50 °C		4	A
I <sub>PLS</sub>	Maximum pulsed switch current, pulse <300 μs, 2% duty cycle		6	A
T <sub>J</sub>	Maximum junction temperature		150	°C
T <sub>LEAD</sub>	Maximum lead temperature (10-s soldering time)		300	°C
T <sub>stg</sub>	Storage temperature	-65	150	°C

- (1) Stresses beyond those listed under *Absolute Maximum Ratings* may cause permanent damage to the device. These are stress ratings only, and functional operation of the device at these or any other conditions beyond those indicated under *Recommended Operating Conditions* is not implied. Exposure to absolute-maximum-rated conditions for extended periods may affect device reliability.
- (2) All voltage values are with respect to network ground terminal.

### 6.2 ESD Ratings

			VALUE	UNIT
V <sub>(ESD)</sub>	Electrostatic discharge	Human Body Model (HBM), per ANSI/ESDA/JEDEC JS-001, all pins <sup>(1)</sup>	±2000	V
		Charged-Device Model (CDM), per JEDEC specification JESD22-C101, all pins <sup>(2)</sup>	±1000	

- (1) JEDEC document JEP155 states that 500-V HBM allows safe manufacturing with a standard ESD control process.
- (2) JEDEC document JEP157 states that 250-V CDM allows safe manufacturing with a standard ESD control process.

### 6.3 Recommended Operating Conditions

			MIN	MAX	UNIT
V <sub>IN1,2</sub>	Input voltage range		0.8	V <sub>BIAS</sub>	V
V <sub>BIAS</sub>	Bias voltage range		2.5	5.5	V
V <sub>ON1,2</sub>	ON voltage range		0	5.5	V
V <sub>OUT1,2</sub>	Output voltage range			V <sub>IN</sub>	V
V <sub>IH, ON1,2</sub>	High-level input voltage, ON1,2	V <sub>BIAS</sub> = 2.5 to 5.5 V	1.2	5.5	V
V <sub>IL, ON1,2</sub>	Low-level input voltage, ON1,2	V <sub>BIAS</sub> = 2.5 to 5.5 V	0	0.5	V
C <sub>IN1,2</sub>	Input capacitor		1 <sup>(1)</sup>		μF
T <sub>A</sub>	Operating free-air temperature <sup>(2)</sup>		-40	125	°C

- (1) Refer to [Application Information](#).
- (2) In applications where high power dissipation and/or poor package thermal resistance is present, the maximum ambient temperature may have to be derated. Maximum ambient temperature [T<sub>A(max)</sub>] is dependent on the maximum operating junction temperature [T<sub>J(max)</sub>], the maximum power dissipation of the device in the application [P<sub>D(max)</sub>], and the junction-to-ambient thermal resistance of the part/package in the application (R<sub>θJA</sub>), as given by the following equation: T<sub>A(max)</sub> = T<sub>J(max)</sub> - (R<sub>θJA</sub> × P<sub>D(max)</sub>).

## 6.4 Thermal Information

THERMAL METRIC <sup>(1) (2)</sup>		TPS22968-Q1	UNIT
		DMG (10 PINS)	
R <sub>θJA</sub>	Junction-to-ambient thermal resistance	55.6	°C/W
R <sub>θJC(top)</sub>	Junction-to-case (top) thermal resistance	71.0	
R <sub>θJB</sub>	Junction-to-board thermal resistance	21.7	
ψ <sub>JT</sub>	Junction-to-top characterization parameter	1.9	
ψ <sub>JB</sub>	Junction-to-board characterization parameter	21.7	
R <sub>θJC(bot)</sub>	Junction-to-case (bottom) thermal resistance	7.3	

(1) For more information about traditional and new thermal metrics, see the *IC Package Thermal Metrics* application report, [SPRA953](#).

(2) For thermal estimates of this device based on PCB copper area, see the [TI PCB Thermal Calculator](#).

## 6.5 Electrical Characteristics (V<sub>BIAS</sub> = 5 V)

V<sub>BIAS</sub> = 5 V. Typical values are for T<sub>A</sub> = 25°C, unless otherwise noted

PARAMETER		TEST CONDITIONS	T <sub>A</sub>	MIN	TYP	MAX	UNIT
<b>POWER SUPPLIES AND CURRENTS</b>							
I <sub>Q</sub> , V <sub>BIAS</sub>	V <sub>BIAS</sub> quiescent current (both channels)	I <sub>OUT1</sub> = I <sub>OUT2</sub> = 0 A, V <sub>IN1,2</sub> = V <sub>ON1,2</sub> = V <sub>BIAS</sub> = 5 V	-40°C to 85°C	58	70		μA
			-40°C to 125°C			70	
I <sub>Q</sub> , V <sub>BIAS</sub>	V <sub>BIAS</sub> quiescent current (single channel)	I <sub>OUT1</sub> = I <sub>OUT2</sub> = 0 A, V <sub>ON2</sub> = 0 V, V <sub>IN1,2</sub> = V <sub>ON1</sub> = V <sub>BIAS</sub> = 5.0 V	-40°C to 85°C	58	68		μA
			-40°C to 125°C			68	
I <sub>SD</sub> , V <sub>BIAS</sub>	V <sub>BIAS</sub> shutdown current	V <sub>ON1,2</sub> = 0 V, V <sub>OUT1,2</sub> = 0 V	-40°C to 85°C	1	2		μA
			-40°C to 125°C			2	
I <sub>SD</sub> , V <sub>IN1,2</sub>	V <sub>IN1,2</sub> shutdown current (per channel)	V <sub>ON1,2</sub> = 0 V, V <sub>OUT1,2</sub> = 0 V	V <sub>IN1,2</sub> = 5 V	-40°C to 85°C	0.5	8	μA
				-40°C to 125°C		36	
			V <sub>IN1,2</sub> = 3.3 V	-40°C to 85°C	0.1	3	
				-40°C to 125°C		13	
			V <sub>IN1,2</sub> = 1.8 V	-40°C to 85°C	0.07	2	
				-40°C to 125°C		6	
I <sub>ON1,2</sub>	ON pin input leakage current	V <sub>ON</sub> = 5.5 V	-40°C to 125°C			0.1	μA
<b>RESISTANCE CHARACTERISTICS</b>							
R <sub>ON</sub>	ON-state resistance	I <sub>OUT</sub> = -200 mA, V <sub>BIAS</sub> = 5 V	V <sub>IN</sub> = 5 V	25°C	29	35	mΩ
				-40°C to 85°C		40	
				-40°C to 125°C		43	
			V <sub>IN</sub> = 3.3 V	25°C	27	32	mΩ
				-40°C to 85°C		36	
				-40°C to 125°C		40	
			V <sub>IN</sub> = 1.8 V	25°C	26	32	mΩ
				-40°C to 85°C		36	
				-40°C to 125°C		39	
			V <sub>IN</sub> = 1.2 V	25°C	26	32	mΩ
				-40°C to 85°C		36	
				-40°C to 125°C		39	
V <sub>IN</sub> = 0.8 V	25°C	26	32	mΩ			
	-40°C to 85°C		36				
	-40°C to 125°C		39				
R <sub>PD</sub>	Output pulldown resistance	V <sub>IN</sub> = 5 V, V <sub>ON</sub> = 0 V, I <sub>OUT</sub> = 5 mA	-40°C to 125°C	270	320		Ω

## 6.6 Electrical Characteristics ( $V_{BIAS} = 3.3\text{ V}$ )

 $V_{BIAS} = 3.3\text{ V}$ . Typical values are for  $T_A = 25^\circ\text{C}$ , unless otherwise noted

PARAMETER		TEST CONDITIONS	$T_A$	MIN	TYP	MAX	UNIT	
<b>POWER SUPPLIES AND CURRENTS</b>								
$I_Q, V_{BIAS}$	$V_{BIAS}$ quiescent current (both channels)	$I_{OUT1} = I_{OUT2} = 0\text{ A}$ , $V_{IN1,2} = V_{ON1,2} = V_{BIAS} = 3.3\text{ V}$	$-40^\circ\text{C}$ to $85^\circ\text{C}$		27	40	$\mu\text{A}$	
			$-40^\circ\text{C}$ to $125^\circ\text{C}$			40		
$I_Q, V_{BIAS}$	$V_{BIAS}$ quiescent current (single channel)	$I_{OUT1} = I_{OUT2} = 0\text{ A}$ , $V_{ON2} = 0\text{ V}$ , $V_{IN1,2} = V_{ON1} = V_{BIAS} = 3.3\text{ V}$	$-40^\circ\text{C}$ to $85^\circ\text{C}$		27	40	$\mu\text{A}$	
			$-40^\circ\text{C}$ to $125^\circ\text{C}$			40		
$I_{SD}, V_{BIAS}$	$V_{BIAS}$ shutdown current	$V_{ON1,2} = 0\text{ V}$ , $V_{OUT1,2} = 0\text{ V}$	$-40^\circ\text{C}$ to $85^\circ\text{C}$		0.5	1	$\mu\text{A}$	
			$-40^\circ\text{C}$ to $125^\circ\text{C}$			1		
$I_{SD}, V_{IN1,2}$	$V_{IN1,2}$ shutdown current (per channel)	$V_{ON1,2} = 0\text{ V}$ , $V_{OUT1,2} = 0\text{ V}$	$V_{IN1,2} = 3.3\text{ V}$	$-40^\circ\text{C}$ to $85^\circ\text{C}$		0.1	3	$\mu\text{A}$
				$-40^\circ\text{C}$ to $125^\circ\text{C}$			13	
			$V_{IN1,2} = 1.8\text{ V}$	$-40^\circ\text{C}$ to $85^\circ\text{C}$		0.07	2	
				$-40^\circ\text{C}$ to $125^\circ\text{C}$			6	
			$V_{IN1,2} = 1.2\text{ V}$	$-40^\circ\text{C}$ to $85^\circ\text{C}$		0.05	1	
				$-40^\circ\text{C}$ to $125^\circ\text{C}$			4	
$V_{IN1,2} = 0.8\text{ V}$	$-40^\circ\text{C}$ to $85^\circ\text{C}$		0.04	1				
	$-40^\circ\text{C}$ to $125^\circ\text{C}$			4				
$I_{ON1,2}$	ON pin input leakage current	$V_{ON} = 5.5\text{ V}$	$-40^\circ\text{C}$ to $125^\circ\text{C}$			0.1	$\mu\text{A}$	
<b>RESISTANCE CHARACTERISTICS</b>								
$R_{ON}$	ON-state resistance	$I_{OUT} = -200\text{ mA}$ , $V_{BIAS} = 3.3\text{ V}$	$V_{IN} = 3.3\text{ V}$	$25^\circ\text{C}$		32	38	$\text{m}\Omega$
				$-40^\circ\text{C}$ to $85^\circ\text{C}$			44	
				$-40^\circ\text{C}$ to $125^\circ\text{C}$			48	
			$V_{IN} = 1.8\text{ V}$	$25^\circ\text{C}$		28	33	$\text{m}\Omega$
				$-40^\circ\text{C}$ to $85^\circ\text{C}$			38	
				$-40^\circ\text{C}$ to $125^\circ\text{C}$			42	
			$V_{IN} = 1.2\text{ V}$	$25^\circ\text{C}$		27	33	$\text{m}\Omega$
				$-40^\circ\text{C}$ to $85^\circ\text{C}$			38	
				$-40^\circ\text{C}$ to $125^\circ\text{C}$			41	
			$V_{IN} = 0.8\text{ V}$	$25^\circ\text{C}$		27	32	$\text{m}\Omega$
				$-40^\circ\text{C}$ to $85^\circ\text{C}$			37	
				$-40^\circ\text{C}$ to $125^\circ\text{C}$			40	
$R_{PD}$	Output pulldown resistance	$V_{IN} = 3.3\text{ V}$ , $V_{ON} = 0\text{ V}$ , $I_{OUT} = 5\text{ mA}$	$-40^\circ\text{C}$ to $125^\circ\text{C}$		270	320	$\Omega$	

## 6.7 Electrical Characteristics ( $V_{BIAS} = 2.5\text{ V}$ )

 $V_{BIAS} = 2.5\text{ V}$ . Typical values are for  $T_A = 25^\circ\text{C}$ , unless otherwise noted

PARAMETER		TEST CONDITIONS	$T_A$	MIN	TYP	MAX	UNIT		
<b>POWER SUPPLIES AND CURRENTS</b>									
$I_Q, V_{BIAS}$	$V_{BIAS}$ quiescent current (both channels)	$I_{OUT1} = I_{OUT2} = 0$ , $V_{IN1,2} = V_{ON1,2} = V_{BIAS} = 2.5\text{ V}$	$-40^\circ\text{C}$ to $85^\circ\text{C}$	19	27		$\mu\text{A}$		
			$-40^\circ\text{C}$ to $125^\circ\text{C}$			27			
$I_Q, V_{BIAS}$	$V_{BIAS}$ quiescent current (single channel)	$I_{OUT1} = I_{OUT2} = 0$ , $V_{ON2} = 0\text{ V}$ , $V_{IN1,2} = V_{ON1} = V_{BIAS} = 2.5\text{ V}$	$-40^\circ\text{C}$ to $85^\circ\text{C}$	19	27		$\mu\text{A}$		
			$-40^\circ\text{C}$ to $125^\circ\text{C}$			27			
$I_{SD}, V_{BIAS}$	$V_{BIAS}$ shutdown current	$V_{ON1,2} = 0\text{ V}$ , $V_{OUT1,2} = 0\text{ V}$	$-40^\circ\text{C}$ to $85^\circ\text{C}$	0.4	1		$\mu\text{A}$		
			$-40^\circ\text{C}$ to $125^\circ\text{C}$			1			
$I_{SD}, V_{IN1,2}$	$V_{IN1,2}$ shutdown current (per channel)	$V_{ON1,2} = 0\text{ V}$ , $V_{OUT1,2} = 0\text{ V}$	$V_{IN1,2} = 2.5\text{ V}$	$-40^\circ\text{C}$ to $85^\circ\text{C}$	0.1	2		$\mu\text{A}$	
				$-40^\circ\text{C}$ to $125^\circ\text{C}$			9		
			$V_{IN1,2} = 1.8\text{ V}$	$-40^\circ\text{C}$ to $85^\circ\text{C}$		0.07	2		
				$-40^\circ\text{C}$ to $125^\circ\text{C}$			6		
			$V_{IN1,2} = 1.2\text{ V}$	$-40^\circ\text{C}$ to $85^\circ\text{C}$		0.05	1		
				$-40^\circ\text{C}$ to $125^\circ\text{C}$			4		
			$V_{IN1,2} = 0.8\text{ V}$	$-40^\circ\text{C}$ to $85^\circ\text{C}$		0.04	1		
				$-40^\circ\text{C}$ to $125^\circ\text{C}$			4		
$I_{ON1,2}$	ON pin input leakage current	$V_{ON} = 5.5\text{ V}$	$-40^\circ\text{C}$ to $125^\circ\text{C}$			0.1	$\mu\text{A}$		
<b>RESISTANCE CHARACTERISTICS</b>									
$R_{ON}$	ON-state resistance	$I_{OUT} = -200\text{ mA}$ , $V_{BIAS} = 2.5\text{ V}$	$V_{IN} = 2.5\text{ V}$	$25^\circ\text{C}$	39	45	$\text{m}\Omega$		
				$-40^\circ\text{C}$ to $85^\circ\text{C}$		52			
				$-40^\circ\text{C}$ to $125^\circ\text{C}$		57			
			$V_{IN} = 1.8\text{ V}$	$25^\circ\text{C}$	34	39	$\text{m}\Omega$		
				$-40^\circ\text{C}$ to $85^\circ\text{C}$		46			
				$-40^\circ\text{C}$ to $125^\circ\text{C}$		50			
			$V_{IN} = 1.2\text{ V}$	$25^\circ\text{C}$	31	37	$\text{m}\Omega$		
				$-40^\circ\text{C}$ to $85^\circ\text{C}$		42			
				$-40^\circ\text{C}$ to $125^\circ\text{C}$		46			
			$V_{IN} = 0.8\text{ V}$	$25^\circ\text{C}$	30	35	$\text{m}\Omega$		
				$-40^\circ\text{C}$ to $85^\circ\text{C}$		41			
				$-40^\circ\text{C}$ to $125^\circ\text{C}$		44			
$R_{PD}$	Output pulldown resistance	$V_{IN} = 2.5\text{ V}$ , $V_{ON} = 0\text{ V}$ , $I_{OUT} = 5\text{ mA}$	$-40^\circ\text{C}$ to $125^\circ\text{C}$		270	320	$\Omega$		

## 6.8 Switching Characteristics

PARAMETER		TEST CONDITIONS	MIN	TYP	MAX	UNIT
<b><math>V_{IN} = V_{ON} = V_{BIAS} = 5\text{ V}</math>, <math>T_A = 25\text{ }^\circ\text{C}</math> (unless otherwise noted)</b>						
$t_{ON}$	Turn-on time	$R_L = 10\ \Omega$ , $C_L = 0.1\ \mu\text{F}$ , $CT = 1000\ \text{pF}$		1150		$\mu\text{s}$
$t_{OFF}$	Turn-off time	$R_L = 10\ \Omega$ , $C_L = 0.1\ \mu\text{F}$ , $CT = 1000\ \text{pF}$		4		
$t_R$	$V_{OUT}$ rise time	$R_L = 10\ \Omega$ , $C_L = 0.1\ \mu\text{F}$ , $CT = 1000\ \text{pF}$		1400		
$t_F$	$V_{OUT}$ fall time	$R_L = 10\ \Omega$ , $C_L = 0.1\ \mu\text{F}$ , $CT = 1000\ \text{pF}$		2		
$t_D$	ON delay time	$R_L = 10\ \Omega$ , $C_L = 0.1\ \mu\text{F}$ , $CT = 1000\ \text{pF}$		469		
<b><math>V_{IN} = 0.8\text{ V}</math>, <math>V_{ON} = V_{BIAS} = 5\text{ V}</math>, <math>T_A = 25\text{ }^\circ\text{C}</math> (unless otherwise noted)</b>						
$t_{ON}$	Turn-on time	$R_L = 10\ \Omega$ , $C_L = 0.1\ \mu\text{F}$ , $CT = 1000\ \text{pF}$		514		$\mu\text{s}$
$t_{OFF}$	Turn-off time	$R_L = 10\ \Omega$ , $C_L = 0.1\ \mu\text{F}$ , $CT = 1000\ \text{pF}$		31		
$t_R$	$V_{OUT}$ rise time	$R_L = 10\ \Omega$ , $C_L = 0.1\ \mu\text{F}$ , $CT = 1000\ \text{pF}$		271		
$t_F$	$V_{OUT}$ fall time	$R_L = 10\ \Omega$ , $C_L = 0.1\ \mu\text{F}$ , $CT = 1000\ \text{pF}$		2		
$t_D$	ON delay time	$R_L = 10\ \Omega$ , $C_L = 0.1\ \mu\text{F}$ , $CT = 1000\ \text{pF}$		382		
<b><math>V_{IN} = 3.3\text{ V}</math>, <math>V_{ON} = 5\text{ V}</math>, <math>V_{BIAS} = 3.3\text{ V}</math>, <math>T_A = 25\text{ }^\circ\text{C}</math> (unless otherwise noted)</b>						
$t_{ON}$	Turn-on time	$R_L = 10\ \Omega$ , $C_L = 0.1\ \mu\text{F}$ , $CT = 1000\ \text{pF}$		1455		$\mu\text{s}$
$t_{OFF}$	Turn-off time	$R_L = 10\ \Omega$ , $C_L = 0.1\ \mu\text{F}$ , $CT = 1000\ \text{pF}$		5		
$t_R$	$V_{OUT}$ rise time	$R_L = 10\ \Omega$ , $C_L = 0.1\ \mu\text{F}$ , $CT = 1000\ \text{pF}$		1592		
$t_F$	$V_{OUT}$ fall time	$R_L = 10\ \Omega$ , $C_L = 0.1\ \mu\text{F}$ , $CT = 1000\ \text{pF}$		2		
$t_D$	ON delay time	$R_L = 10\ \Omega$ , $C_L = 0.1\ \mu\text{F}$ , $CT = 1000\ \text{pF}$		681		
<b><math>V_{IN} = 0.8\text{ V}</math>, <math>V_{ON} = 5\text{ V}</math>, <math>V_{BIAS} = 3.3\text{ V}</math>, <math>T_A = 25\text{ }^\circ\text{C}</math> (unless otherwise noted)</b>						
$t_{ON}$	Turn-on time	$R_L = 10\ \Omega$ , $C_L = 0.1\ \mu\text{F}$ , $CT = 1000\ \text{pF}$		805		$\mu\text{s}$
$t_{OFF}$	Turn-off time	$R_L = 10\ \Omega$ , $C_L = 0.1\ \mu\text{F}$ , $CT = 1000\ \text{pF}$		31		
$t_R$	$V_{OUT}$ rise time	$R_L = 10\ \Omega$ , $C_L = 0.1\ \mu\text{F}$ , $CT = 1000\ \text{pF}$		455		
$t_F$	$V_{OUT}$ fall time	$R_L = 10\ \Omega$ , $C_L = 0.1\ \mu\text{F}$ , $CT = 1000\ \text{pF}$		2		
$t_D$	ON delay time	$R_L = 10\ \Omega$ , $C_L = 0.1\ \mu\text{F}$ , $CT = 1000\ \text{pF}$		577		
<b><math>V_{IN} = 2.5\text{ V}</math>, <math>V_{ON} = 5\text{ V}</math>, <math>V_{BIAS} = 2.5\text{ V}</math>, <math>T_A = 25\text{ }^\circ\text{C}</math> (unless otherwise noted)</b>						
$t_{ON}$	Turn-on time	$R_L = 10\ \Omega$ , $C_L = 0.1\ \mu\text{F}$ , $CT = 1000\ \text{pF}$		1800		$\mu\text{s}$
$t_{OFF}$	Turn-off time	$R_L = 10\ \Omega$ , $C_L = 0.1\ \mu\text{F}$ , $CT = 1000\ \text{pF}$		6		
$t_R$	$V_{OUT}$ rise time	$R_L = 10\ \Omega$ , $C_L = 0.1\ \mu\text{F}$ , $CT = 1000\ \text{pF}$		1830		
$t_F$	$V_{OUT}$ fall time	$R_L = 10\ \Omega$ , $C_L = 0.1\ \mu\text{F}$ , $CT = 1000\ \text{pF}$		2		
$t_D$	ON delay time	$R_L = 10\ \Omega$ , $C_L = 0.1\ \mu\text{F}$ , $CT = 1000\ \text{pF}$		909		
<b><math>V_{IN} = 0.8\text{ V}</math>, <math>V_{ON} = 5\text{ V}</math>, <math>V_{BIAS} = 2.5\text{ V}</math>, <math>T_A = 25\text{ }^\circ\text{C}</math> (unless otherwise noted)</b>						
$t_{ON}$	Turn-on time	$R_L = 10\ \Omega$ , $C_L = 0.1\ \mu\text{F}$ , $CT = 1000\ \text{pF}$		1140		$\mu\text{s}$
$t_{OFF}$	Turn-off time	$R_L = 10\ \Omega$ , $C_L = 0.1\ \mu\text{F}$ , $CT = 1000\ \text{pF}$		28		
$t_R$	$V_{OUT}$ rise time	$R_L = 10\ \Omega$ , $C_L = 0.1\ \mu\text{F}$ , $CT = 1000\ \text{pF}$		664		
$t_F$	$V_{OUT}$ fall time	$R_L = 10\ \Omega$ , $C_L = 0.1\ \mu\text{F}$ , $CT = 1000\ \text{pF}$		2		
$t_D$	ON delay time	$R_L = 10\ \Omega$ , $C_L = 0.1\ \mu\text{F}$ , $CT = 1000\ \text{pF}$		798		

### 6.9 Typical DC Characteristics

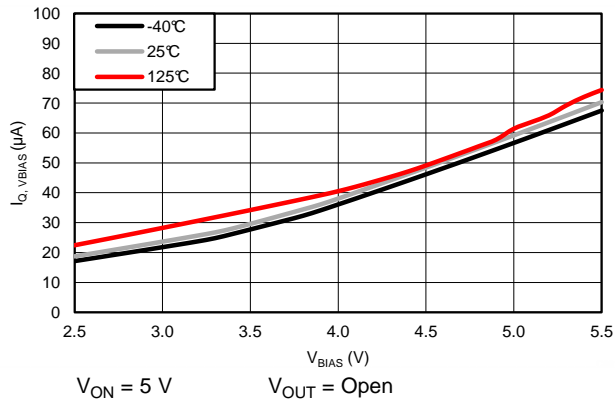

Figure 1.  $I_{Q, VBIAS}$  vs  $V_{BIAS}$  (Single Channel)

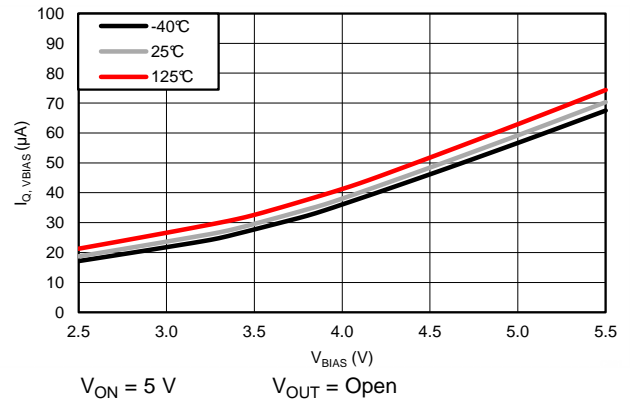

Figure 2.  $I_{Q, VBIAS}$  vs  $V_{BIAS}$  (Dual Channel)

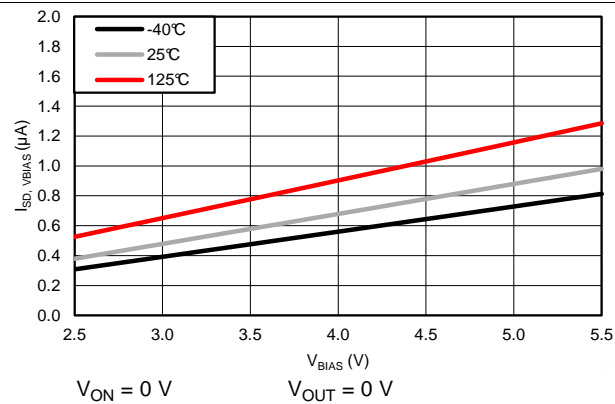

Figure 3.  $I_{SD, VBIAS}$  vs  $V_{BIAS}$

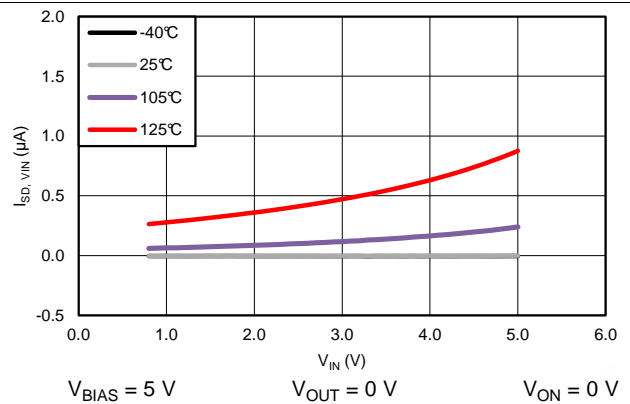

Figure 4.  $I_{SD, VIN}$  vs  $V_{IN}$  (One Channel)

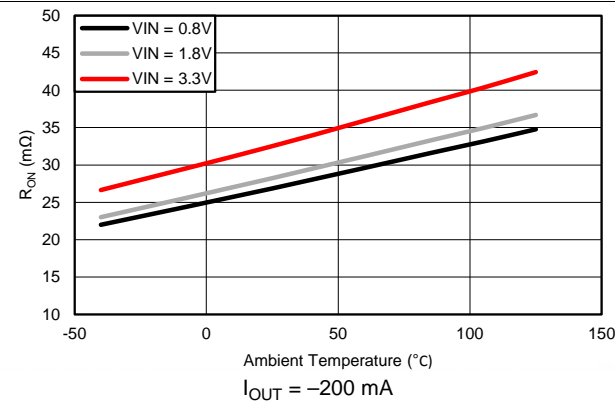

Figure 5.  $R_{ON}$  vs Ambient Temperature,  $V_{BIAS} = 3.3V$

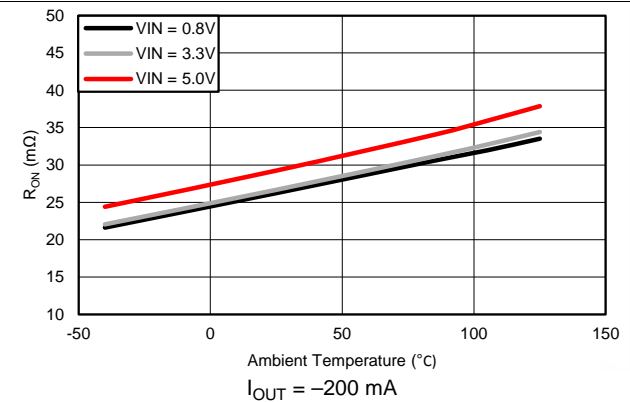

Figure 6.  $R_{ON}$  vs Ambient Temperature,  $V_{BIAS} = 5V$

Typical DC Characteristics (continued)

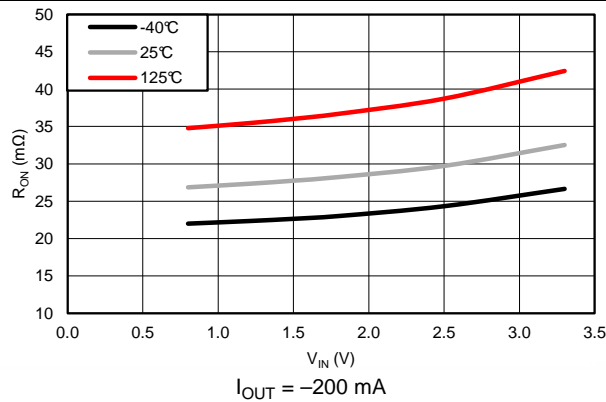

Figure 7.  $R_{ON}$  vs  $V_{IN}$ ,  $V_{BIAS} = 3.3$  V

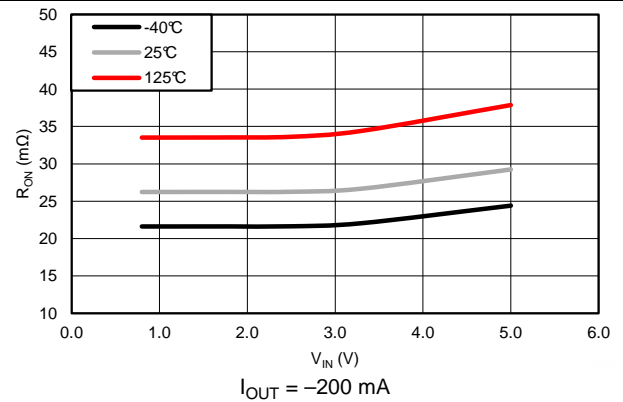

Figure 8.  $R_{ON}$  vs  $V_{IN}$ ,  $V_{BIAS} = 5$  V

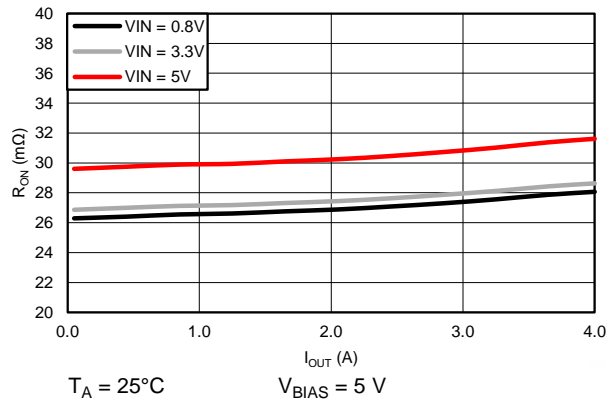

Figure 9.  $R_{ON}$  vs  $I_{OUT}$

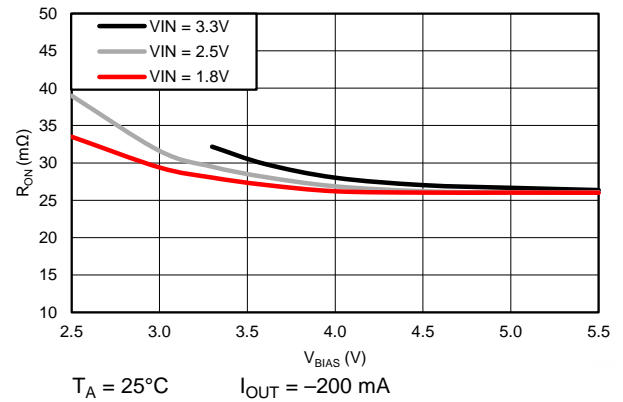

Figure 10.  $R_{ON}$  vs  $V_{BIAS}$

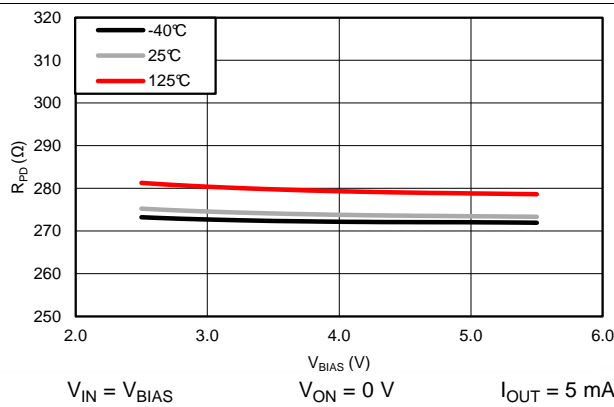

Figure 11.  $R_{PD}$  vs  $V_{BIAS}$

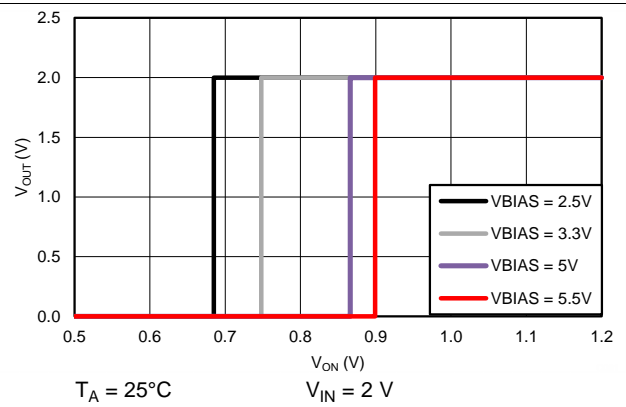

Figure 12.  $V_{OUT}$  vs  $V_{ON}$

### 6.10 Typical AC Characteristics

$C_{IN} = 1 \mu F$ ,  $C_L = 0.1 \mu F$ ,  $R_L = 10 \Omega$ ,  $C_T = 1 \text{ nF}$  (unless otherwise specified)

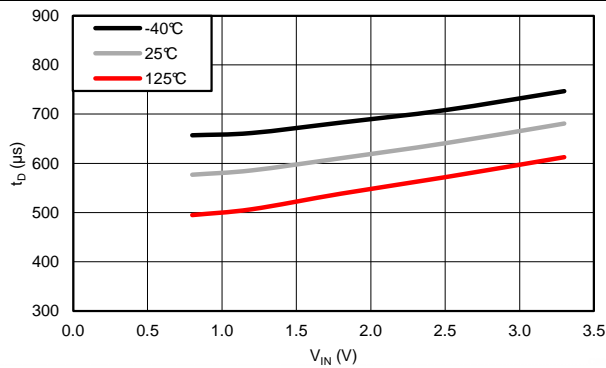

Figure 13.  $t_D$  vs  $V_{IN}$ ,  $V_{BIAS} = 3.3 \text{ V}$

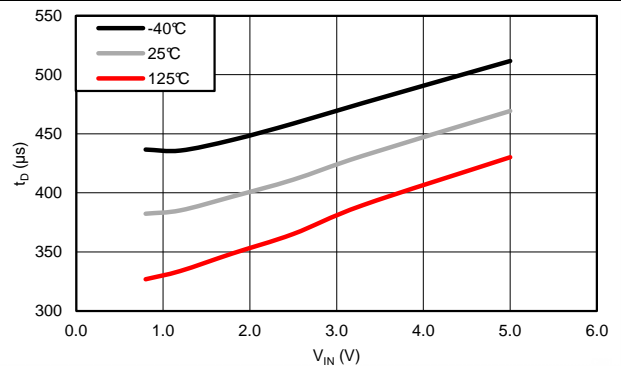

Figure 14.  $t_D$  vs  $V_{IN}$ ,  $V_{BIAS} = 5 \text{ V}$

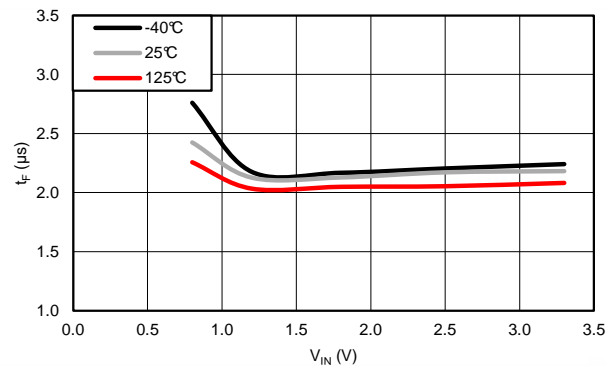

Figure 15.  $t_F$  vs  $V_{IN}$ ,  $V_{BIAS} = 3.3 \text{ V}$

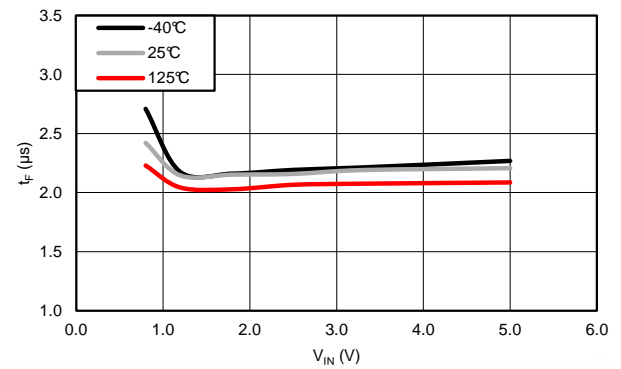

Figure 16.  $t_F$  vs  $V_{IN}$ ,  $V_{BIAS} = 5 \text{ V}$

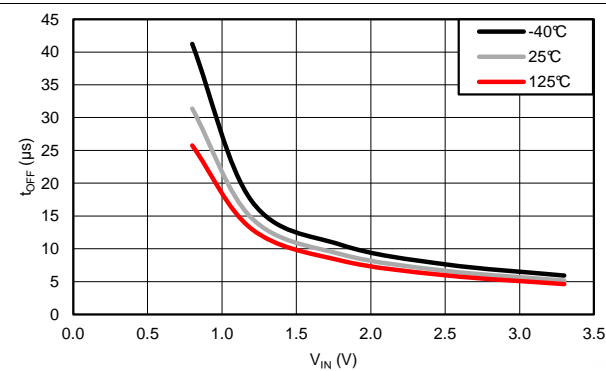

Figure 17.  $t_{OFF}$  vs  $V_{IN}$ ,  $V_{BIAS} = 3.3 \text{ V}$

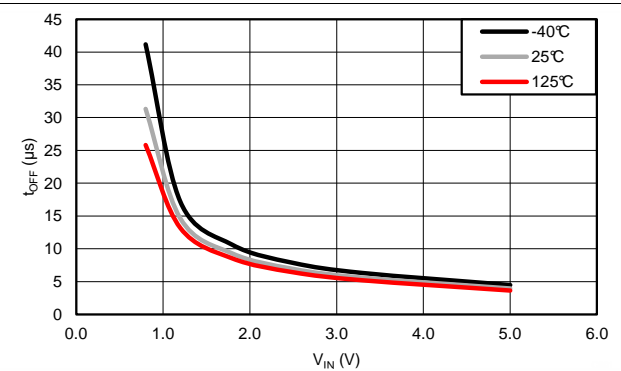

Figure 18.  $t_{OFF}$  vs  $V_{IN}$ ,  $V_{BIAS} = 5 \text{ V}$

Typical AC Characteristics (continued)

$C_{IN} = 1 \mu F$ ,  $C_L = 0.1 \mu F$ ,  $R_L = 10 \Omega$ ,  $C_T = 1 \text{ nF}$  (unless otherwise specified)

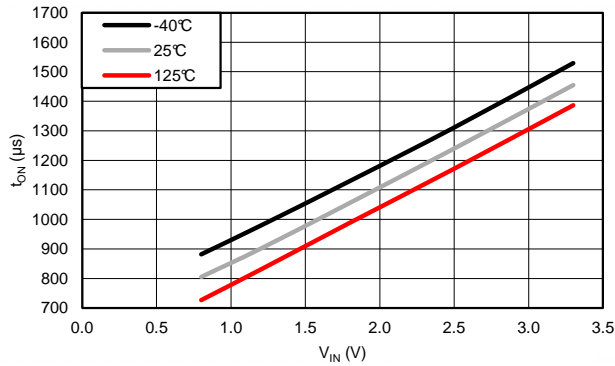

Figure 19.  $t_{ON}$  vs  $V_{IN}$ ,  $V_{BIAS} = 3.3 \text{ V}$

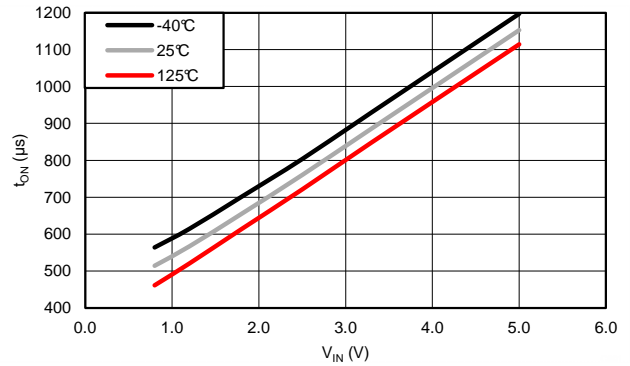

Figure 20.  $t_{ON}$  vs  $V_{IN}$ ,  $V_{BIAS} = 5 \text{ V}$

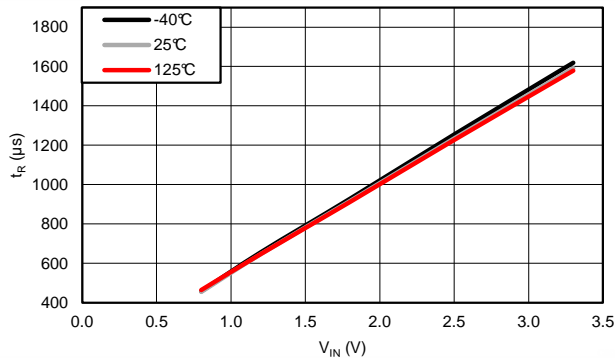

Figure 21.  $t_R$  vs  $V_{IN}$ ,  $V_{BIAS} = 3.3 \text{ V}$

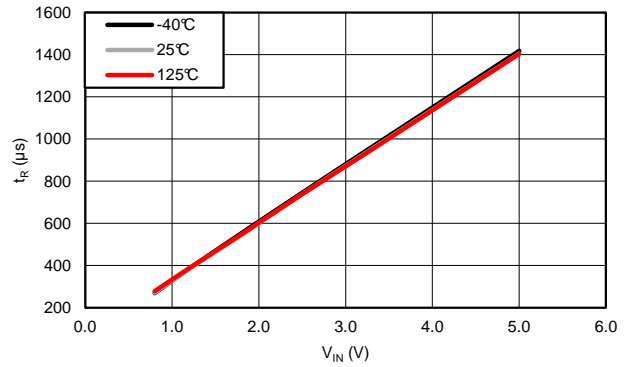

Figure 22.  $t_R$  vs  $V_{IN}$ ,  $V_{BIAS} = 5 \text{ V}$

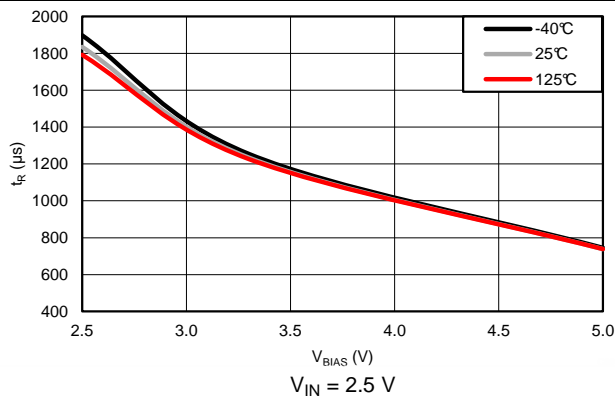

Figure 23.  $t_R$  vs  $V_{BIAS}$

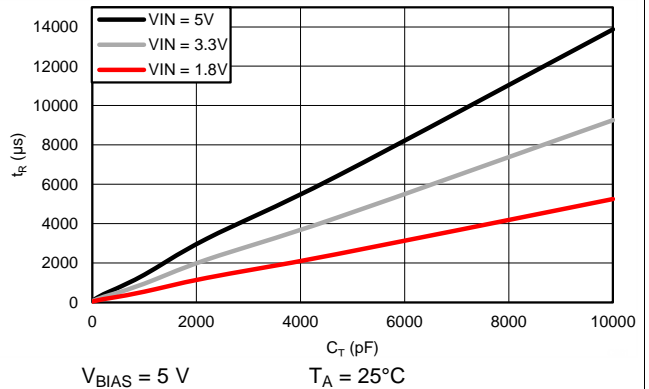

Figure 24.  $t_R$  vs  $C_T$

Typical AC Characteristics (continued)

$C_{IN} = 1 \mu\text{F}$ ,  $C_L = 0.1 \mu\text{F}$ ,  $R_L = 10 \Omega$ ,  $C_T = 1 \text{ nF}$  (unless otherwise specified)

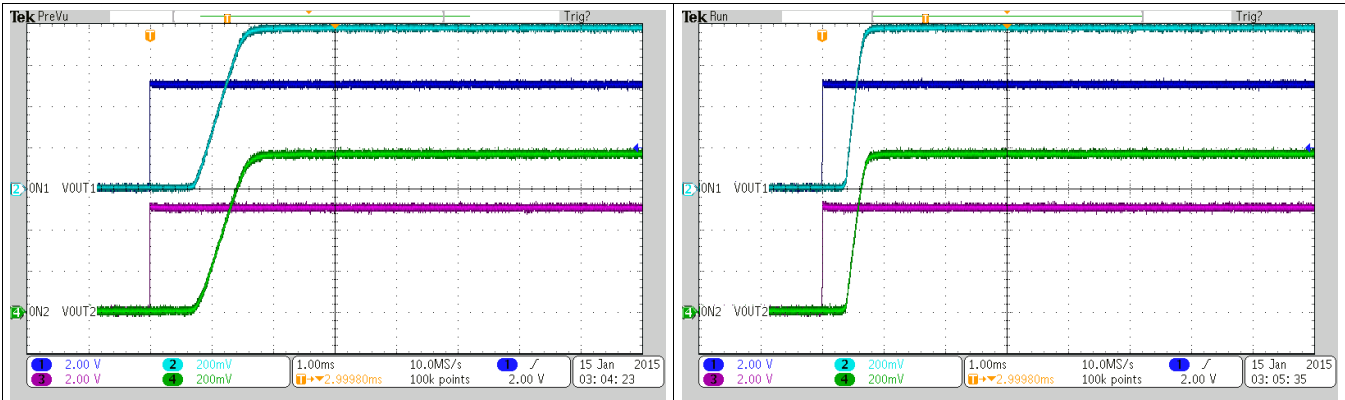

Figure 25. Turn-On Response Time ( $V_{IN} = 0.8 \text{ V}$ ,  $V_{BIAS} = 2.5 \text{ V}$ )

Figure 26. Turn-On Response Time ( $V_{IN} = 0.8 \text{ V}$ ,  $V_{BIAS} = 5 \text{ V}$ )

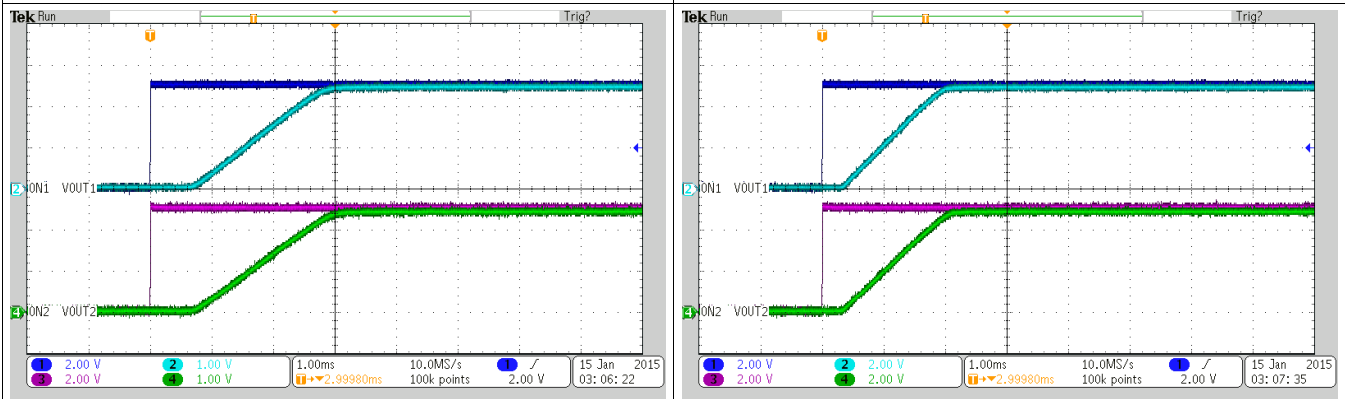

Figure 27. Turn-On Response Time ( $V_{IN} = 2.5 \text{ V}$ ,  $V_{BIAS} = 2.5 \text{ V}$ )

Figure 28. Turn-On Response Time ( $V_{IN} = 5 \text{ V}$ ,  $V_{BIAS} = 5 \text{ V}$ )

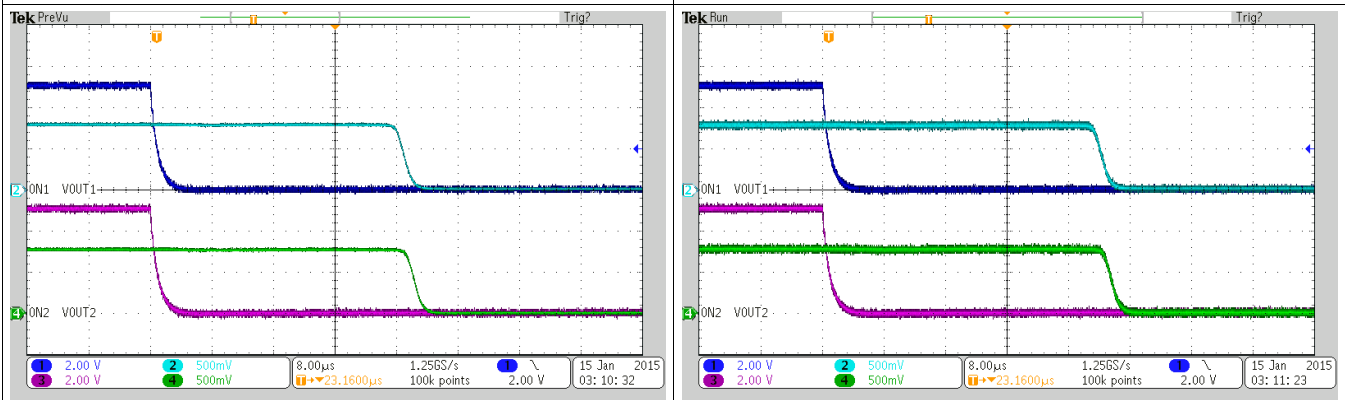

Figure 29. Turn-Off Response Time ( $V_{IN} = 0.8 \text{ V}$ ,  $V_{BIAS} = 2.5 \text{ V}$ )

Figure 30. Turn-Off Response Time ( $V_{IN} = 0.8 \text{ V}$ ,  $V_{BIAS} = 5 \text{ V}$ )

Typical AC Characteristics (continued)

$C_{IN} = 1 \mu F$ ,  $C_L = 0.1 \mu F$ ,  $R_L = 10 \Omega$ ,  $C_T = 1 \text{ nF}$  (unless otherwise specified)

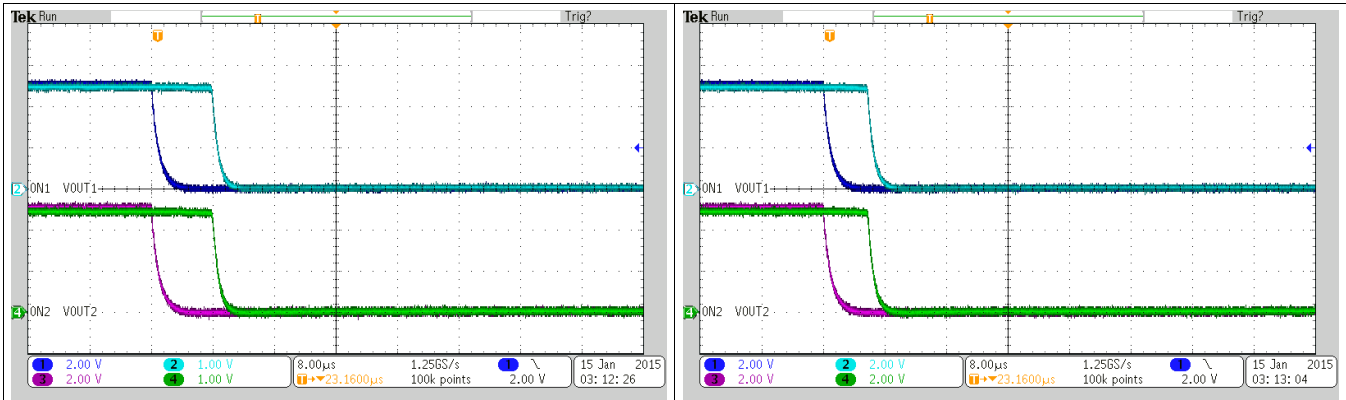
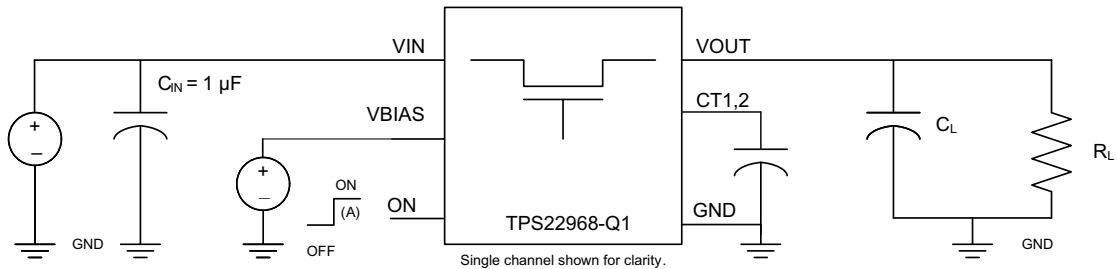

Figure 31. Turn-Off Response Time ( $V_{IN} = 2.5 \text{ V}$ ,  $V_{BIAS} = 2.5 \text{ V}$ )

Figure 32. Turn-Off Response Time ( $V_{IN} = 5 \text{ V}$ ,  $V_{BIAS} = 5 \text{ V}$ )

7 Parameter Measurement Information



Test Circuit

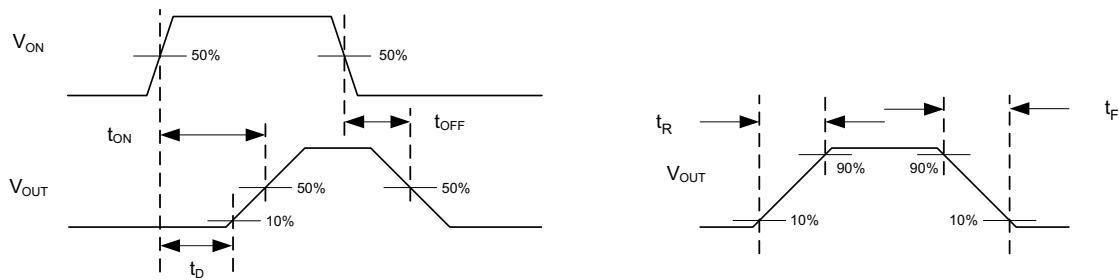

Timing Waveforms

A. Rise and fall times of the control signal is 100 ns.

Figure 33. Test Circuit and Timing Waveforms

## 8 Detailed Description

### 8.1 Overview

The device is a 5.5-V, 4-A, dual-channel ultra-low  $R_{ON}$  load switch with controlled turn on. The device contains two N-channel MOSFETs. Each channel can support a maximum continuous current of 4 A. Each channel is controlled by an on/off GPIO-compatible input. The ON pin must be connected and cannot be left floating. The device is designed to control the turn-on rate and therefore the inrush current. By controlling the inrush current, power supply sag can be reduced during turn-on. The slew rate for each channel is set by connecting a capacitor to GND on the CT pins.

The slew rate is proportional to the capacitor on the CT pin. Refer to [Adjustable Rise Time](#) to determine the correct CT value for a desired rise time.

The internal circuitry is powered by the VBIAS pin, which supports voltages from 2.5 to 5.5 V. This circuitry includes the charge pump, QOD, and control logic. For these internal blocks to function correctly, a voltage between 2.5 and 5.5 V must be supplied to VBIAS.

When a voltage is supplied to VBIAS and the ON1, 2 pin goes low, the QOD turns on. This connects VOUT1, 2 to GND through an on-chip resistor. The typical pulldown resistance ( $R_{PD}$ ) is 270  $\Omega$ .

### 8.2 Functional Block Diagram

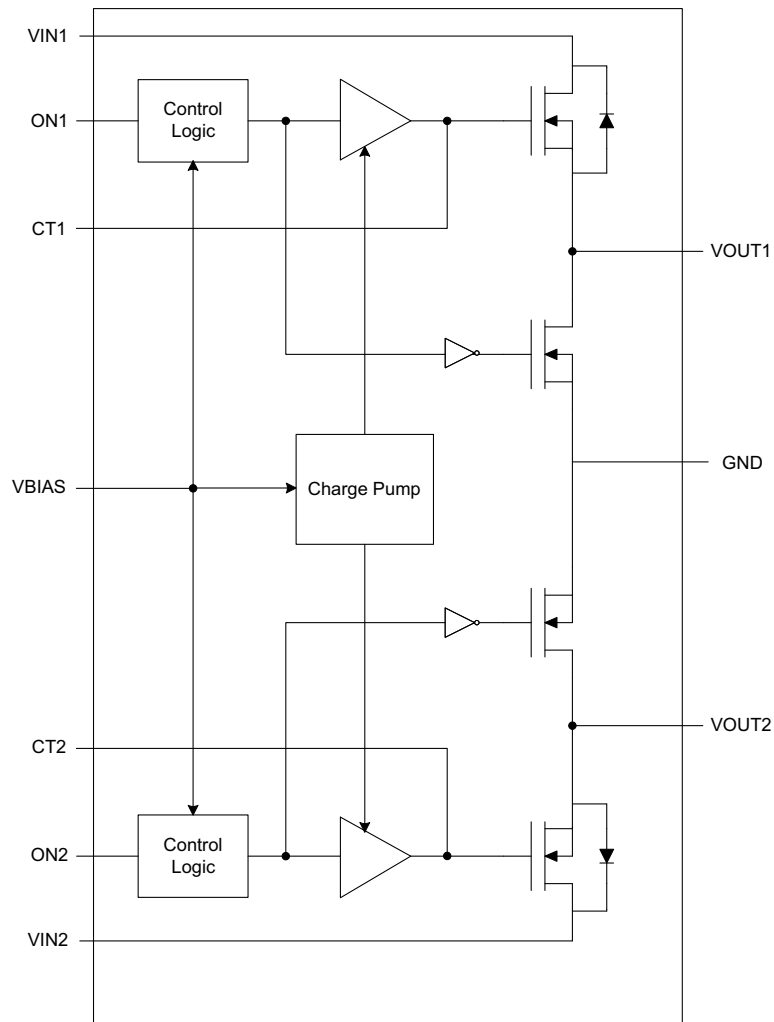

## 8.3 Feature Description

### 8.3.1 ON/OFF Control

The ON pins control the state of the switch. Asserting ON high enables the switch. ON is active high and has a low threshold, making it capable of interfacing with low-voltage signals. The ON pin is compatible with standard GPIO logic threshold. It can be used with any microcontroller with 1.2-V or higher GPIO voltage. This pin cannot be left floating and must be tied either high or low for proper functionality.

### 8.3.2 Quick Output Discharge (QOD)

The TPS22968-Q1 includes a QOD feature. When the switch is disabled, a discharge resistor is connected between VOUT and GND. This resistor has a typical value of 270  $\Omega$  and prevents the output from floating while the switch is disabled.

### 8.3.3 Adjustable Rise Time

A capacitor to GND on the CT pins sets the slew rate for each channel. The capacitor to GND on the CT pins should be rated for 25 V and above. An approximate formula for the relationship between CT and slew rate with  $V_{BIAS} = 5\text{ V}$  is:

$$SR = 0.35 \times CT + 25$$

where

- SR = slew rate (in  $\mu\text{s/V}$ )
- CT = the capacitance value on the CT pin (in pF)
- The units for the constant 25 is in  $\mu\text{s/V}$ .

(1)

Rise time can be calculated by multiplying the input voltage by the slew rate. [Table 1](#) contains rise time values measured on a typical device.

**Table 1. Rise Time Table**

CTx (pF)	Rise Time ( $\mu\text{s}$ ) <sup>(1)</sup> <sup>(2)</sup>					
	$V_{IN} = 5\text{ V}$	$V_{IN} = 3.3\text{ V}$	$V_{IN} = 2.5\text{ V}$	$V_{IN} = 1.8\text{ V}$	$V_{IN} = 1.2\text{ V}$	$V_{IN} = 0.8\text{ V}$
0	84	63	52	43	35	27
220	418	285	223	168	122	88
470	711	479	372	276	196	139
1000	1405	952	738	545	385	271
2200	3236	2174	1684	1246	876	615
4700	6415	4306	3317	2454	1725	1217
10000	13872	9261	7150	5253	3694	2591

(1) 10% - 90%,  $C_L = 0.1\ \mu\text{F}$ ,  $C_{IN} = 1\ \mu\text{F}$ ,  $R_L = 10\ \Omega$ ,  $V_{BIAS} = 5\text{ V}$

(2) Typical values at 25°C with a 25-V X7R 10% ceramic capacitor on CT

## 8.4 Device Functional Modes

**Table 2. Functional Table**

ONx	VINx to VOUTx	VOUTx to GND
L	Off	On
H	On	Off

## 9 Application and Implementation

### NOTE

Information in the following applications sections is not part of the TI component specification, and TI does not warrant its accuracy or completeness. TI's customers are responsible for determining suitability of components for their purposes. Customers should validate and test their design implementation to confirm system functionality.

### 9.1 Application Information

This section highlights some of the design considerations for implementing this device in various applications. A PSPICE model for this device is also available on the [product page](#) for further aid.

#### 9.1.1 Input Capacitor (Optional)

To limit the voltage drop on the input supply caused by transient inrush currents when the switch turns on into a discharged load capacitor, a capacitor must be placed between VIN and GND. A 1- $\mu$ F ceramic capacitor,  $C_{IN}$ , placed close to the pins, is usually sufficient. Higher values of  $C_{IN}$  can be used to further reduce the voltage drop during high-current applications. When switching heavy loads, TI recommends to have an input capacitor about 10x higher than the output capacitor to avoid excessive voltage drop.

#### 9.1.2 Output Capacitor (Optional)

Due to the integrated body diode in the NMOS switch, TI highly recommends a  $C_{IN}$  greater than  $C_L$ . A  $C_L$  greater than  $C_{IN}$  can cause the voltage on VOUT to exceed VIN when the system supply is removed. This could result in current flow through the body diode from VOUT to VIN. TI recommends a  $C_{IN}$  to  $C_L$  ratio of 10 to 1 for minimizing VIN dip caused by inrush currents during startup.

#### 9.1.3 VIN and VBIAS Voltage Range

For optimal  $R_{ON}$  performance, make sure  $V_{IN} \leq V_{BIAS}$ . The device is still functional if  $V_{IN} > V_{BIAS}$ , but it will exhibit  $R_{ON}$  greater than what is listed in the [Electrical Characteristics \( \$V\_{BIAS} = 5\text{ V}\$ \)](#) and [Electrical Characteristics \( \$V\_{BIAS} = 2.5\text{ V}\$ \)](#). See [Figure 34](#) for an example of a typical device. Notice the increasing  $R_{ON}$  as  $V_{IN}$  exceeds  $V_{BIAS}$  voltage. Be sure to never exceed the maximum voltage rating for  $V_{IN}$  and  $V_{BIAS}$ .

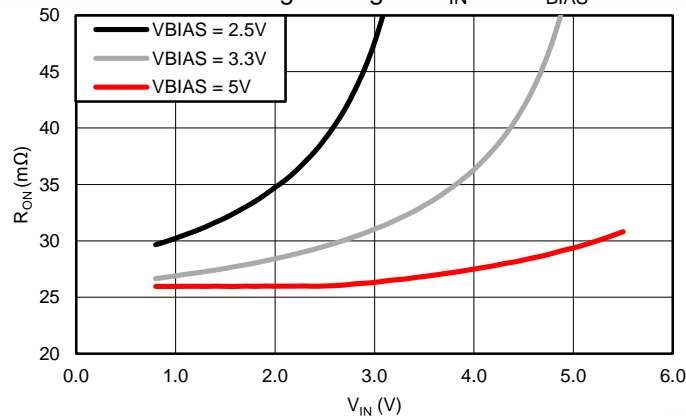

$T_A = 25^\circ\text{C}$

$I_{OUT} = -200\text{ mA}$

Figure 34.  $R_{ON}$  vs  $V_{IN}$

## Application Information (continued)

### 9.1.3.1 Parallel Configuration

To increase the current capabilities and lower the  $R_{ON}$  by approximately 50%, both channels can be placed in parallel as shown in Figure 35 (parallel configuration). With this configuration, the CT1 and CT2 pins can be tied together to use one capacitor, CT, as shown in Figure 35. With a single CT capacitor, the rise time will be half of the typical rise-time value. Refer to the Table 1 for typical timing values.

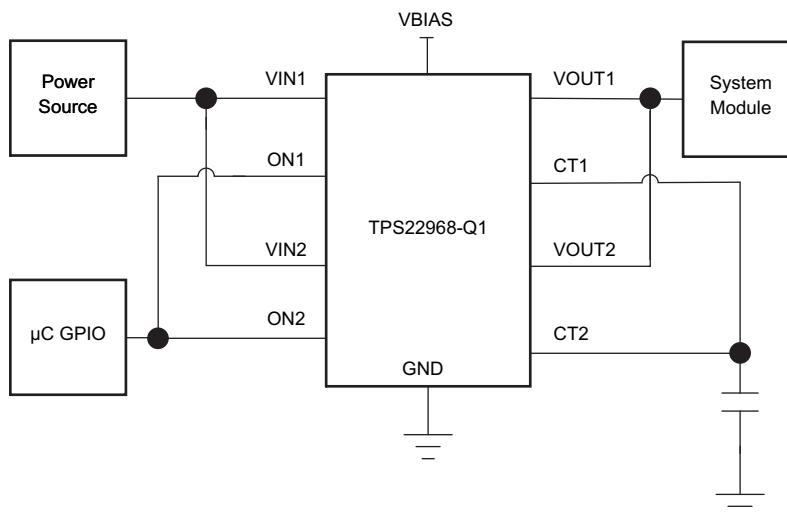

**Figure 35. Parallel Configuration Schematic**

### 9.1.3.2 Standby Power Reduction

TPS22968-Q1 can help to reduce the standby power consumption of a module. Some loads will consume a non-trivial amount of power when turned off. If the power to the load is removed by the load switch, the standby power consumption can be significantly reduced.

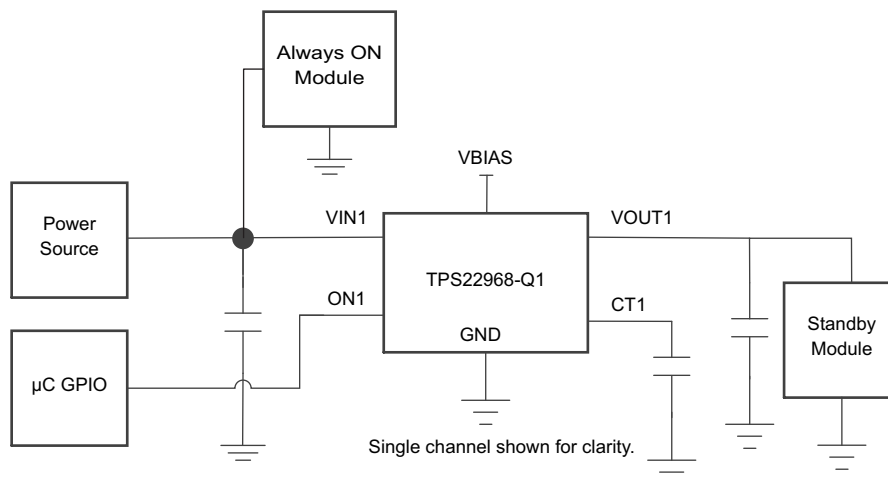
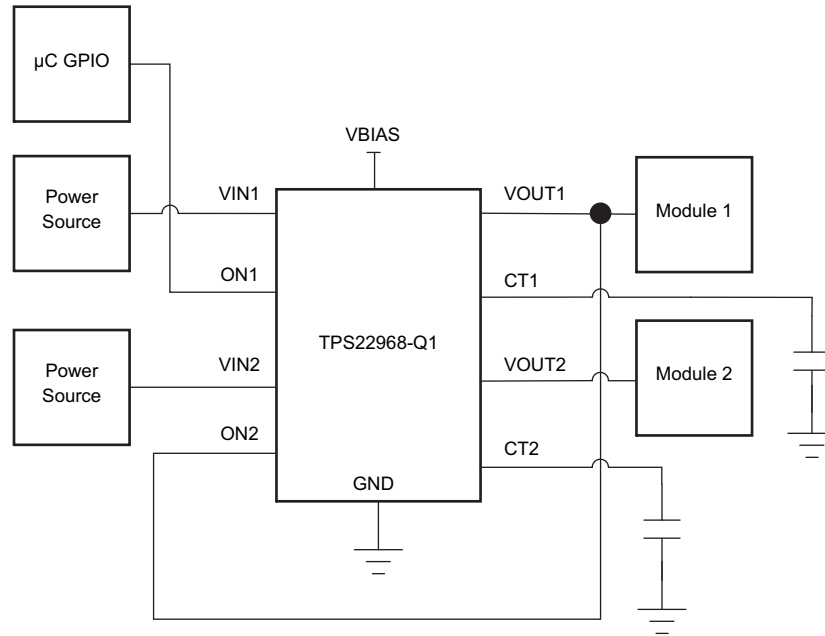

**Figure 36. Standby Power Reduction Schematic**

## Application Information (continued)

### 9.1.3.3 Power Supply Sequencing Without a GPIO Input

In many end equipments, there is a need to power up various modules in a predetermined manner. TPS22968-Q1 can solve the problem of power sequencing without adding any complexity to the overall system.



A. VIN1 must be greater  $V_{IH}$ .

**Figure 37. Power Sequencing Without a GPIO Input Schematic**

### 9.1.3.4 Reverse Current Blocking

In certain applications, it may be desirable to have reverse current blocking. Reverse current blocking prevents current from flowing from the output to the input of the load switch when the device is disabled. With the following configuration, the TPS22968-Q1 can be converted into a single-channel switch with reverse current blocking. In this configuration, VIN1 or VIN2 can be used as the input and VIN2 or VIN1 is the output.

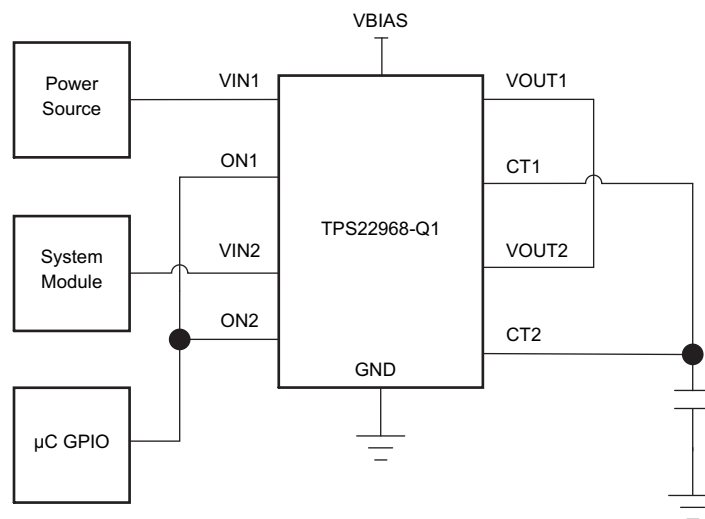

**Figure 38. Reverse Current Blocking Schematic**

## 9.2 Typical Application

This application demonstrates how the TPS22968-Q1 can be used to power a downstream load with a large capacitance. The example in [Figure 39](#) is powering a 22- $\mu\text{F}$  capacitive output load.

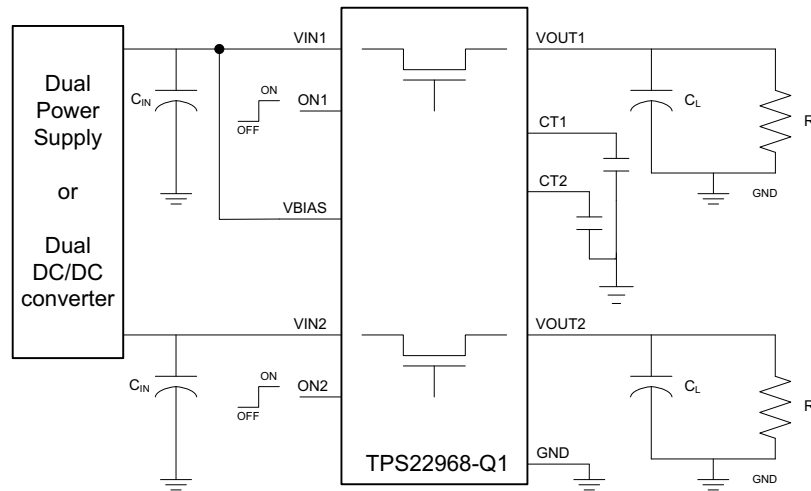

**Figure 39. Typical Application Schematic for Powering a Downstream Module**

### 9.2.1 Design Requirements

For this design example, use the following as the input parameters.

**Table 3. Design Parameters**

DESIGN PARAMETER	EXAMPLE VALUE
$V_{IN}$	3.3 V
$V_{BIAS}$	5.0 V
Output capacitance ( $C_L$ )	22 $\mu\text{F}$
Allowable inrush current on VOUT	0.400 A

### 9.2.2 Detailed Design Procedure

To begin the design process, the designer needs to know the following:

- $V_{IN}$  voltage
- $V_{BIAS}$  voltage
- Output capacitance ( $C_L$ )
- Allowable inrush current on VOUT due to  $C_L$  capacitor

#### 9.2.2.1 Inrush Current

To determine how much inrush current will be caused by the  $C_L$  capacitor, use [Equation 2](#).

$$I_{INRUSH} = C_L \times \frac{dV_{OUT}}{dt}$$

where

- $I_{INRUSH}$  = amount of inrush current caused by  $C_L$
- $C_L$  = capacitance on VOUT
- $dt = V_{OUT}$  rise time
- $dV_{OUT}$  = increase in  $V_{OUT}$  during the rise time (2)

Inrush current is proportional to rise time. The rise time is adjustable by use of the CT capacitor. The appropriate rise time can be calculated using the design requirements and the inrush current equation ([Equation 2](#)).

$$400 \text{ mA} = 22 \mu\text{F} \times 3.3 \text{ V} / dt \quad (3)$$

$$dt = 182 \mu\text{s} \quad (4)$$

To ensure an inrush current of less than 400 mA, choose a CT capacitor value that will yield a rise time of more than 182  $\mu$ s. See the oscilloscope captures in the [Application Curves](#) for an example of how the CT capacitor can be used to reduce inrush current. See [Table 1](#) for correlation between rise times and CT values.

An appropriate  $C_L$  value should be placed on VOUT such that the  $I_{MAX}$  and  $I_{PLS}$  specifications of the device are not violated.

### 9.2.3 Application Curves

The two scope captures below show how the CT capacitor can be used to reduce inrush current.

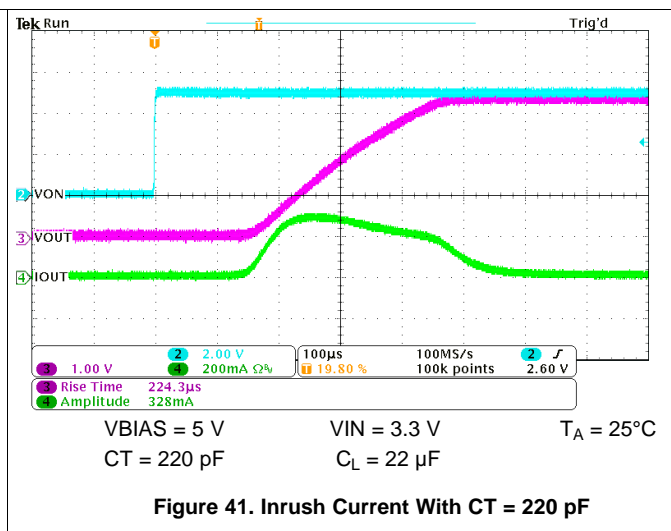
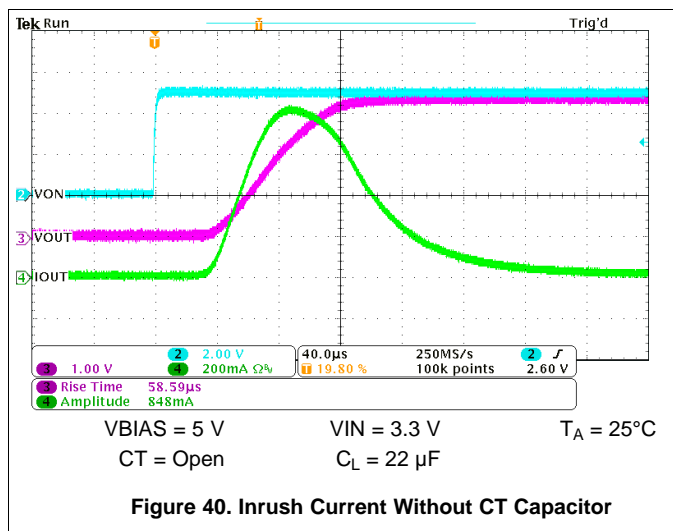

## 10 Power Supply Recommendations

The device is designed to operate from a  $V_{BIAS}$  range of 2.5 to 5.5 V and  $V_{IN}$  range of 0.8 to 5.5 V. This supply must be well regulated and placed as close to the device pin as possible with the recommended 1- $\mu$ F bypass capacitor. If the supply is located more than a few inches from the device pins, additional bulk capacitance may be required in addition to the ceramic bypass capacitors. If additional bulk capacitance is required, an electrolytic, tantalum, or ceramic capacitor of 10  $\mu$ F may be sufficient.

## 11 Layout

### 11.1 Layout Guidelines

- $V_{IN}$  and  $V_{OUT}$  traces should be as short and wide as possible to accommodate for high current.
- Use vias under the exposed thermal pad for thermal relief for high current operation.
- $V_{INx}$  pins should be bypassed to ground with low-ESR ceramic bypass capacitors. The typical recommended bypass capacitance is 1- $\mu$ F ceramic with X5R or X7R dielectric. This capacitor should be placed as close to the device pins as possible.
- $V_{OUTx}$  pins should be bypassed to ground with low-ESR ceramic bypass capacitors. The typical recommended bypass capacitance is one-tenth of the  $V_{INx}$  bypass capacitor of X5R or X7R dielectric rating. This capacitor should be placed as close to the device pins as possible.
- The  $V_{BIAS}$  pin should be bypassed to ground with low-ESR ceramic bypass capacitors. The typical recommended bypass capacitance is 0.1- $\mu$ F ceramic with X5R or X7R dielectric.
- The  $CTx$  capacitors should be placed as close to the device pins as possible. The typical recommended  $CTx$  capacitance is a capacitor of X5R or X7R dielectric rating with a rating of 25 V or higher.

## 11.2 Layout Example

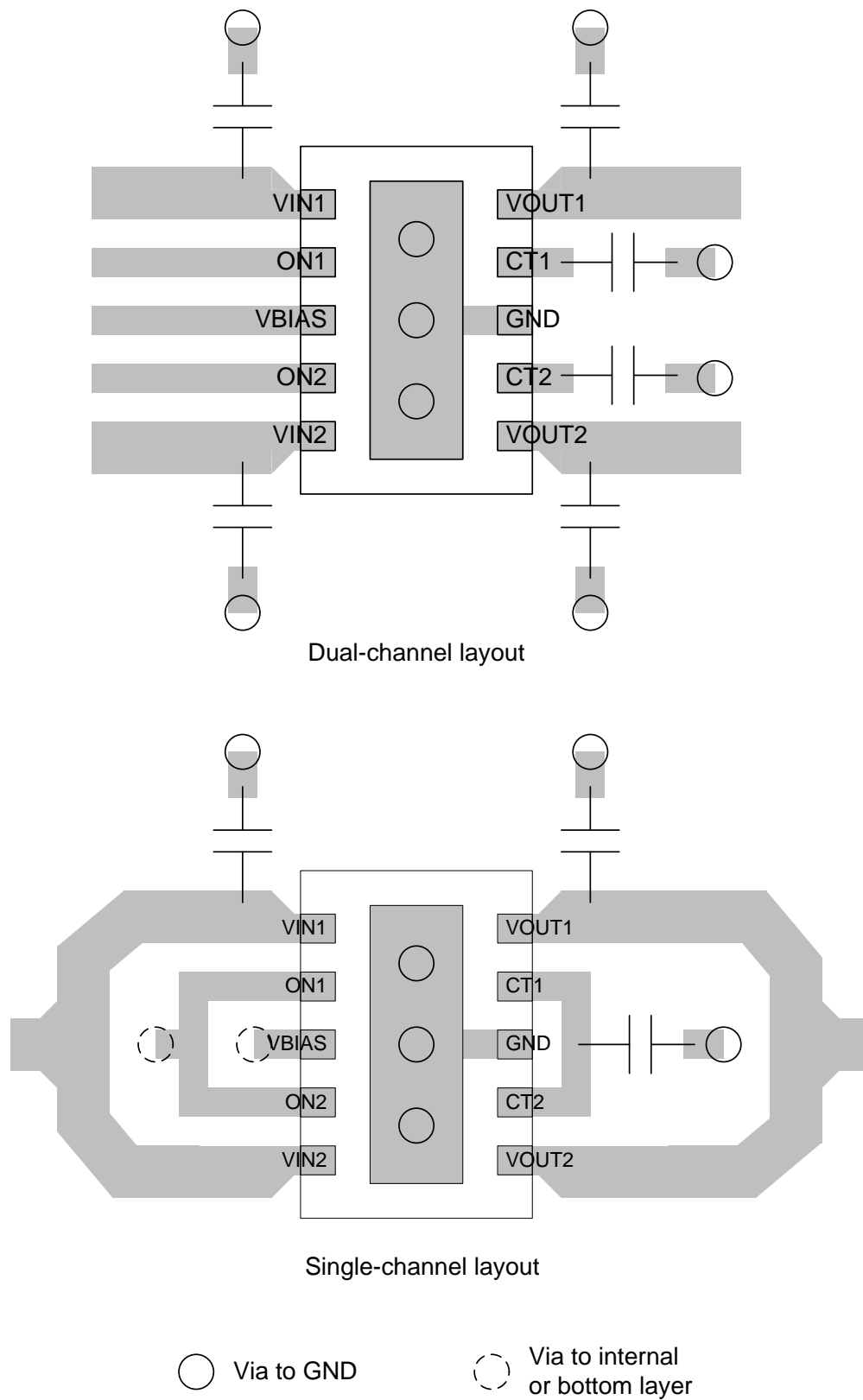

Figure 42. Layout Schematic

### 11.3 Thermal Considerations

The maximum IC junction temperature should be restricted to 150°C under normal operating conditions. To calculate the maximum allowable dissipation,  $P_{D(max)}$  for a given ambient temperature, use [Equation 5](#).

$$P_{D(MAX)} = \frac{T_{J(MAX)} - T_A}{R_{\theta JA}}$$

where

- $P_{D(max)}$  = maximum allowable power dissipation
- $T_{J(max)}$  = maximum allowable junction temperature (150°C for the TPS22968-Q1)
- $T_A$  = ambient temperature of the device
- $R_{\theta JA}$  = junction to air thermal impedance. See [Thermal Information](#). This parameter is highly dependent upon board layout. (5)

Following are two examples demonstrating how to use the above information: For  $V_{BIAS} = 5\text{ V}$ ,  $V_{IN} = 5\text{ V}$ , the maximum allowable ambient temperature with a 3-A load through each channel can be determined by using the following calculations.

#### NOTE

When calculating power dissipation in the switch, it is important to use the correct  $R_{ON}$  value.  $R_{ON}$  is dependent on the junction temperature of the device.

$$P_D = I^2 \times R \times 2 \text{ (multiplied by 2 because there are two channels)} \quad (6)$$

$$2 \times I^2 \times R = \frac{T_{J(MAX)} - T_A}{R_{\theta JA}} \quad (7)$$

$$T_A = T_{J(MAX)} - R_{\theta JA} \times 2 \times I^2 \times R \quad (8)$$

$$T_A = 150^\circ\text{C} - 55.6^\circ\text{C/W} \times 2 \times (3\text{ A})^2 \times 45\text{ m}\Omega = 105^\circ\text{C} \quad (9)$$

For  $V_{BIAS} = 5\text{ V}$ ,  $V_{IN} = 5\text{ V}$ , the maximum continuous current for an ambient temperature of 85°C with the same current flowing through each channel can be determined by using the following calculation:

$$2 \times I^2 \times R = \frac{T_{J(MAX)} - T_A}{R_{\theta JA}} \quad (10)$$

$$I = \sqrt{\frac{T_{J(MAX)} - T_A}{2 \times R \times R_{\theta JA}}} \quad (11)$$

$$I = \sqrt{\frac{150^\circ\text{C} - 85^\circ\text{C}}{2 \times 45\text{ m}\Omega \times 55.6^\circ\text{C/W}}} = 3.6\text{ A} \quad (12)$$

## 12 器件和文档支持

### 12.1 商标

All trademarks are the property of their respective owners.

### 12.2 静电放电警告



这些装置包含有限的内置 ESD 保护。存储或装卸时，应将导线一起截短或将装置放置于导电泡棉中，以防止 MOS 门极遭受静电损伤。

### 12.3 术语表

[SLYZ022](#) — TI 术语表。

这份术语表列出并解释术语、首字母缩略词和定义。

## 13 机械封装和可订购信息

以下页中包括机械封装和可订购信息。 这些信息是针对指定器件可提供的最新数据。 这些数据会在无通知且不对本文档进行修订的情况下发生改变。 欲获得该数据表的浏览器版本，请查阅左侧的导航栏。

## 重要声明

德州仪器(TI)及其下属子公司有权根据 JESD46 最新标准,对所提供的产品和服务进行更正、修改、增强、改进或其它更改,并有权根据 JESD48 最新标准中止提供任何产品和服务。客户在下订单前应获取最新的相关信息,并验证这些信息是否完整且是最新的。所有产品的销售都遵循在订单确认时所提供的TI 销售条款与条件。

TI 保证其所销售的组件的性能符合产品销售时 TI 半导体产品销售条件与条款的适用规范。仅在 TI 保证的范围内,且 TI 认为有必要时才会使用测试或其它质量控制技术。除非适用法律做出了硬性规定,否则没有必要对每种组件的所有参数进行测试。

TI 对应用帮助或客户产品设计不承担任何义务。客户应对其使用 TI 组件的产品和应用自行负责。为尽量减小与客户产品和应用相关的风险,客户应提供充分的设计与操作安全措施。

TI 不对任何 TI 专利权、版权、屏蔽作品权或其它与使用了 TI 组件或服务的组合设备、机器或流程相关的 TI 知识产权中授予的直接或隐含权限作出任何保证或解释。TI 所发布的与第三方产品或服务有关的信息,不能构成从 TI 获得使用这些产品或服务的许可、授权、或认可。使用此类信息可能需要获得第三方的专利权或其它知识产权方面的许可,或是 TI 的专利权或其它知识产权方面的许可。

对于 TI 的产品手册或数据表中 TI 信息的重要部分,仅在没有对内容进行任何篡改且带有相关授权、条件、限制和声明的情况下才允许进行复制。TI 对此类篡改过的文件不承担任何责任或义务。复制第三方的信息可能需要服从额外的限制条件。

在转售 TI 组件或服务时,如果对该组件或服务参数的陈述与 TI 标明的参数相比存在差异或虚假成分,则会失去相关 TI 组件或服务的所有明示或暗示授权,且这是不正当的、欺诈性商业行为。TI 对任何此类虚假陈述均不承担任何责任或义务。

客户认可并同意,尽管任何应用相关信息或支持仍可能由 TI 提供,但他们将独立负责满足与其产品及其在应用中使用的 TI 产品相关的所有法律、法规和安全相关要求。客户声明并同意,他们具备制定与实施安全措施所需的全部专业技术和知识,可预见故障的危险后果、监测故障及其后果、降低有可能造成人身伤害的故障的发生机率并采取适当的补救措施。客户将全额赔偿因在此类安全关键应用中使用任何 TI 组件而对 TI 及其代理造成的任何损失。

在某些场合中,为了推进安全相关应用有可能对 TI 组件进行特别的促销。TI 的目标是利用此类组件帮助客户设计和创立其特有的可满足适用的功能安全性标准和要求的终端产品解决方案。尽管如此,此类组件仍然服从这些条款。

TI 组件未获得用于 FDA Class III (或类似的生命攸关医疗设备)的授权许可,除非各方授权官员已经达成了专门管控此类使用的特别协议。

只有那些 TI 特别注明属于军用等级或“增强型塑料”的 TI 组件才是设计或专门用于军事/航空应用或环境的。购买者认可并同意,对并非指定面向军事或航空航天用途的 TI 组件进行军事或航空航天方面的应用,其风险由客户单独承担,并且由客户独立负责满足与此类使用相关的所有法律和法规要求。

TI 已明确指定符合 ISO/TS16949 要求的产品,这些产品主要用于汽车。在任何情况下,因使用非指定产品而无法达到 ISO/TS16949 要求, TI 不承担任何责任。

	产品		应用
数字音频	<a href="http://www.ti.com.cn/audio">www.ti.com.cn/audio</a>	通信与电信	<a href="http://www.ti.com.cn/telecom">www.ti.com.cn/telecom</a>
放大器和线性器件	<a href="http://www.ti.com.cn/amplifiers">www.ti.com.cn/amplifiers</a>	计算机及周边	<a href="http://www.ti.com.cn/computer">www.ti.com.cn/computer</a>
数据转换器	<a href="http://www.ti.com.cn/dataconverters">www.ti.com.cn/dataconverters</a>	消费电子	<a href="http://www.ti.com.cn/consumer-apps">www.ti.com.cn/consumer-apps</a>
DLP® 产品	<a href="http://www.dlp.com">www.dlp.com</a>	能源	<a href="http://www.ti.com.cn/energy">www.ti.com.cn/energy</a>
DSP - 数字信号处理器	<a href="http://www.ti.com.cn/dsp">www.ti.com.cn/dsp</a>	工业应用	<a href="http://www.ti.com.cn/industrial">www.ti.com.cn/industrial</a>
时钟和计时器	<a href="http://www.ti.com.cn/clockandtimers">www.ti.com.cn/clockandtimers</a>	医疗电子	<a href="http://www.ti.com.cn/medical">www.ti.com.cn/medical</a>
接口	<a href="http://www.ti.com.cn/interface">www.ti.com.cn/interface</a>	安防应用	<a href="http://www.ti.com.cn/security">www.ti.com.cn/security</a>
逻辑	<a href="http://www.ti.com.cn/logic">www.ti.com.cn/logic</a>	汽车电子	<a href="http://www.ti.com.cn/automotive">www.ti.com.cn/automotive</a>
电源管理	<a href="http://www.ti.com.cn/power">www.ti.com.cn/power</a>	视频和影像	<a href="http://www.ti.com.cn/video">www.ti.com.cn/video</a>
微控制器 (MCU)	<a href="http://www.ti.com.cn/microcontrollers">www.ti.com.cn/microcontrollers</a>		
RFID 系统	<a href="http://www.ti.com.cn/rfidsys">www.ti.com.cn/rfidsys</a>		
OMAP应用处理器	<a href="http://www.ti.com/omap">www.ti.com/omap</a>		
无线连通性	<a href="http://www.ti.com.cn/wirelessconnectivity">www.ti.com.cn/wirelessconnectivity</a>	德州仪器在线技术支持社区	<a href="http://www.deyisupport.com">www.deyisupport.com</a>

邮寄地址: 上海市浦东新区世纪大道1568号, 中建大厦32楼邮政编码: 200122  
Copyright © 2015, 德州仪器半导体技术(上海)有限公司

**PACKAGING INFORMATION**

Orderable Device	Status (1)	Package Type	Package Drawing	Pins	Package Qty	Eco Plan (2)	Lead finish/ Ball material (6)	MSL Peak Temp (3)	Op Temp (°C)	Device Marking (4/5)	Samples
TPS22968NQDMGRQ1	ACTIVE	WSON	DMG	10	3000	RoHS & Green	SN	Level-3-260C-168 HR	-40 to 125	11C	<a href="#">Samples</a>
TPS22968NQDMGTQ1	ACTIVE	WSON	DMG	10	250	RoHS & Green	SN	Level-3-260C-168 HR	-40 to 125	11C	<a href="#">Samples</a>
TPS22968QDMGRQ1	ACTIVE	WSON	DMG	10	3000	RoHS & Green	SN	Level-3-260C-168 HR	-40 to 125	SIV	<a href="#">Samples</a>
TPS22968QDMGTQ1	ACTIVE	WSON	DMG	10	250	RoHS & Green	SN	Level-3-260C-168 HR	-40 to 125	SIV	<a href="#">Samples</a>

(1) The marketing status values are defined as follows:

**ACTIVE:** Product device recommended for new designs.

**LIFEBUY:** TI has announced that the device will be discontinued, and a lifetime-buy period is in effect.

**NRND:** Not recommended for new designs. Device is in production to support existing customers, but TI does not recommend using this part in a new design.

**PREVIEW:** Device has been announced but is not in production. Samples may or may not be available.

**OBSOLETE:** TI has discontinued the production of the device.

(2) **RoHS:** TI defines "RoHS" to mean semiconductor products that are compliant with the current EU RoHS requirements for all 10 RoHS substances, including the requirement that RoHS substance do not exceed 0.1% by weight in homogeneous materials. Where designed to be soldered at high temperatures, "RoHS" products are suitable for use in specified lead-free processes. TI may reference these types of products as "Pb-Free".

**RoHS Exempt:** TI defines "RoHS Exempt" to mean products that contain lead but are compliant with EU RoHS pursuant to a specific EU RoHS exemption.

**Green:** TI defines "Green" to mean the content of Chlorine (Cl) and Bromine (Br) based flame retardants meet JS709B low halogen requirements of <=1000ppm threshold. Antimony trioxide based flame retardants must also meet the <=1000ppm threshold requirement.

(3) MSL, Peak Temp. - The Moisture Sensitivity Level rating according to the JEDEC industry standard classifications, and peak solder temperature.

(4) There may be additional marking, which relates to the logo, the lot trace code information, or the environmental category on the device.

(5) Multiple Device Markings will be inside parentheses. Only one Device Marking contained in parentheses and separated by a "-" will appear on a device. If a line is indented then it is a continuation of the previous line and the two combined represent the entire Device Marking for that device.

(6) Lead finish/Ball material - Orderable Devices may have multiple material finish options. Finish options are separated by a vertical ruled line. Lead finish/Ball material values may wrap to two lines if the finish value exceeds the maximum column width.

**Important Information and Disclaimer:** The information provided on this page represents TI's knowledge and belief as of the date that it is provided. TI bases its knowledge and belief on information provided by third parties, and makes no representation or warranty as to the accuracy of such information. Efforts are underway to better integrate information from third parties. TI has taken and

continues to take reasonable steps to provide representative and accurate information but may not have conducted destructive testing or chemical analysis on incoming materials and chemicals. TI and TI suppliers consider certain information to be proprietary, and thus CAS numbers and other limited information may not be available for release.

In no event shall TI's liability arising out of such information exceed the total purchase price of the TI part(s) at issue in this document sold by TI to Customer on an annual basis.

**TAPE AND REEL INFORMATION**

**QUADRANT ASSIGNMENTS FOR PIN 1 ORIENTATION IN TAPE**

\*All dimensions are nominal

Device	Package Type	Package Drawing	Pins	SPQ	Reel Diameter (mm)	Reel Width W1 (mm)	A0 (mm)	B0 (mm)	K0 (mm)	P1 (mm)	W (mm)	Pin1 Quadrant
TPS22968NQDMGRQ1	WSON	DMG	10	3000	179.0	8.4	2.3	3.2	1.0	4.0	8.0	Q1
TPS22968NQDMGTQ1	WSON	DMG	10	250	179.0	8.4	2.3	3.2	1.0	4.0	8.0	Q1
TPS22968QDMGRQ1	WSON	DMG	10	3000	179.0	8.4	2.3	3.2	1.0	4.0	8.0	Q1
TPS22968QDMGTQ1	WSON	DMG	10	250	179.0	8.4	2.3	3.2	1.0	4.0	8.0	Q1

**TAPE AND REEL BOX DIMENSIONS**

\*All dimensions are nominal

Device	Package Type	Package Drawing	Pins	SPQ	Length (mm)	Width (mm)	Height (mm)
TPS22968NQDMGRQ1	WSON	DMG	10	3000	213.0	191.0	35.0
TPS22968NQDMGTQ1	WSON	DMG	10	250	213.0	191.0	35.0
TPS22968QDMGRQ1	WSON	DMG	10	3000	213.0	191.0	35.0
TPS22968QDMGTQ1	WSON	DMG	10	250	213.0	191.0	35.0

# DMG0010A



# PACKAGE OUTLINE

## WSON - 0.8 mm max height

PLASTIC SMALL OUTLINE - NO LEAD

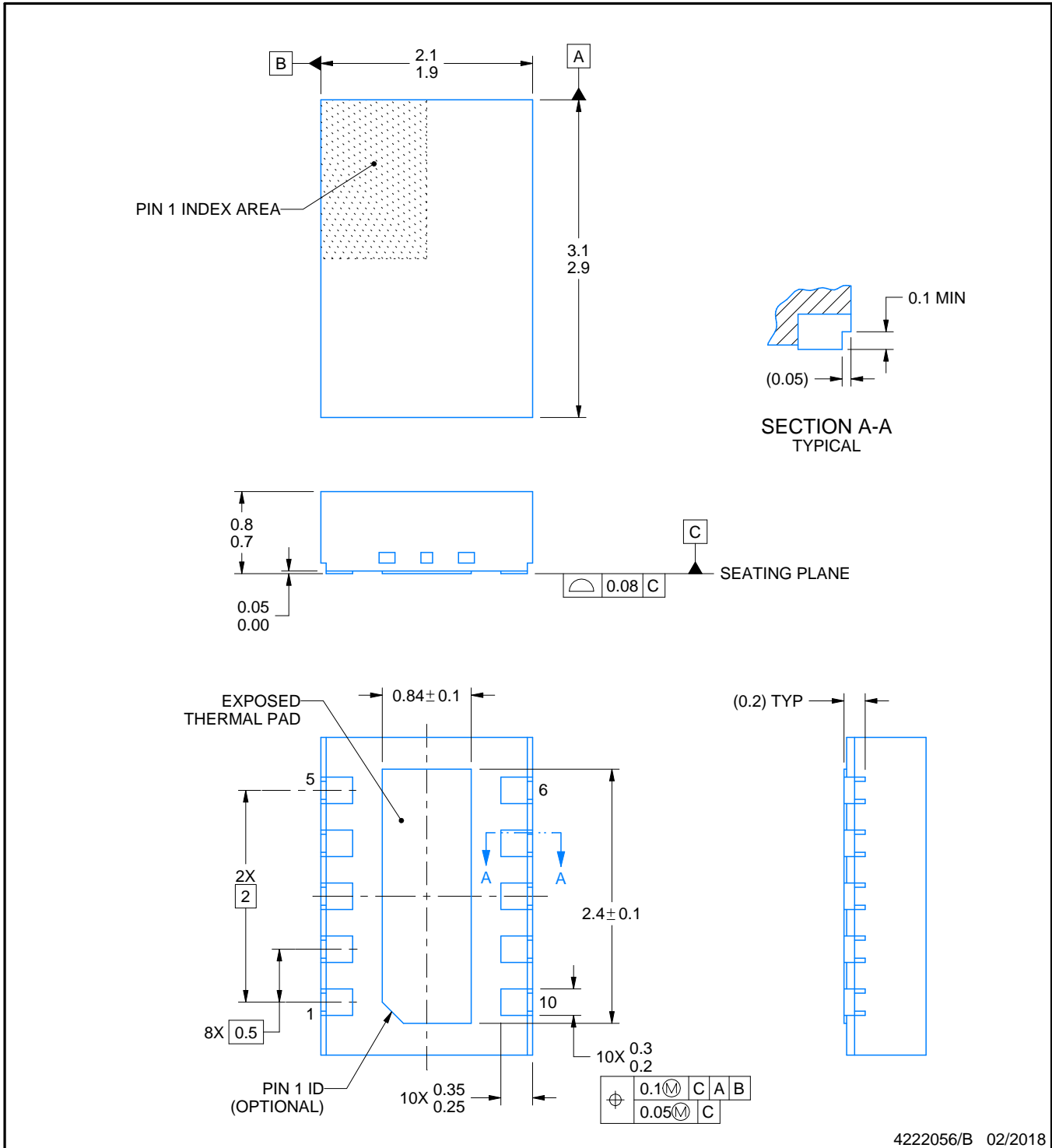

4222056/B 02/2018

**NOTES:**

1. All linear dimensions are in millimeters. Any dimensions in parenthesis are for reference only. Dimensioning and tolerancing per ASME Y14.5M.
2. This drawing is subject to change without notice.
3. The package thermal pad must be soldered to the printed circuit board for thermal and mechanical performance.

# EXAMPLE BOARD LAYOUT

DMG0010A

WSON - 0.8 mm max height

PLASTIC SMALL OUTLINE - NO LEAD

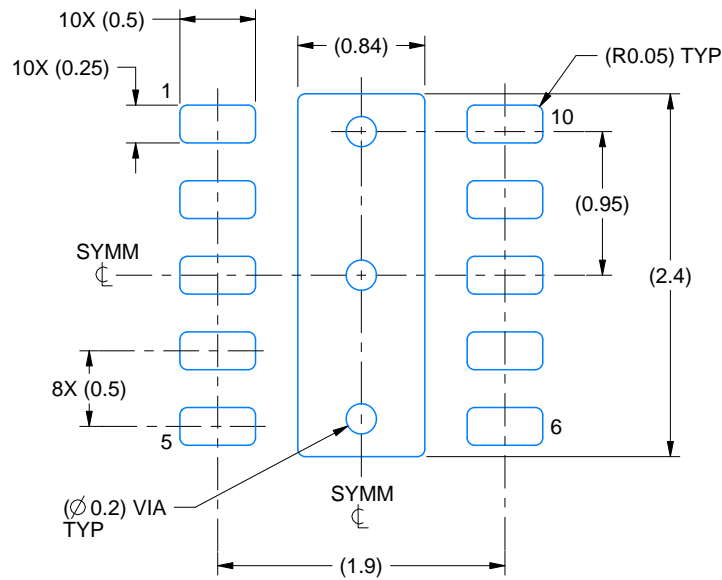

LAND PATTERN EXAMPLE  
EXPOSED METAL SHOWN  
SCALE:20X

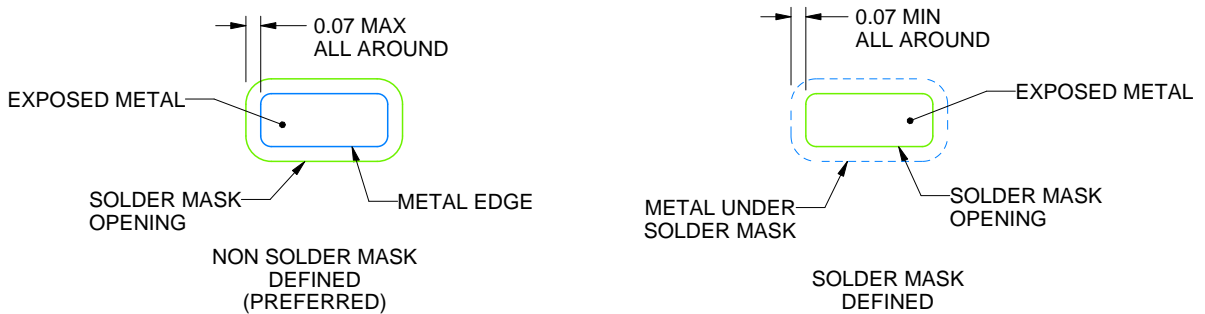

SOLDER MASK DETAILS

4222056/B 02/2018

NOTES: (continued)

4. This package is designed to be soldered to a thermal pad on the board. For more information, see Texas Instruments literature number SLUA271 ([www.ti.com/lit/slua271](http://www.ti.com/lit/slua271)).



## 重要声明和免责声明

TI 提供技术和可靠性数据（包括数据表）、设计资源（包括参考设计）、应用或其他设计建议、网络工具、安全信息和其他资源，不保证没有瑕疵且不做任何明示或暗示的担保，包括但不限于对适销性、某特定用途方面的适用性或不侵犯任何第三方知识产权的暗示担保。

这些资源可供使用 TI 产品进行设计的熟练开发人员使用。您将自行承担以下全部责任：(1) 针对您的应用选择合适的 TI 产品，(2) 设计、验证并测试您的应用，(3) 确保您的应用满足相应标准以及任何其他安全、安保或其他要求。这些资源如有变更，恕不另行通知。TI 授权您仅可将这些资源用于研发本资源所述的 TI 产品的应用。严禁对这些资源进行其他复制或展示。您无权使用任何其他 TI 知识产权或任何第三方知识产权。您应全额赔偿因在这些资源的使用中对 TI 及其代表造成的任何索赔、损害、成本、损失和债务，TI 对此概不负责。

TI 提供的产品受 TI 的销售条款 (<https://www.ti.com.cn/zh-cn/legal/termsofsale.html>) 或 [ti.com.cn](https://www.ti.com.cn) 上其他适用条款/TI 产品随附的其他适用条款的约束。TI 提供这些资源并不会扩展或以其他方式更改 TI 针对 TI 产品发布的适用的担保或担保免责声明。

邮寄地址：上海市浦东新区世纪大道 1568 号中建大厦 32 楼，邮政编码：200122

Copyright © 2021 德州仪器半导体技术（上海）有限公司