

DRV8899-Q1 Automotive Stepper Driver with Integrated Current Sense and 1/256 Micro-Stepping

1 Features

- AEC-Q100 Qualified for Automotive
- Up to 1/256 microstepping
- Integrated current sense functionality
 - No sense resistors required
- Smart tune decay technology, Fixed slow, and mixed decay options
- 4.5 to 45-V Operating supply voltage range
- Pin to pin $R_{DS(ON)}$ variants:
 - **DRV8889/A-Q1**: 900 m Ω HS + LS at 25°C
 - **DRV8899-Q1**: 1200 m Ω HS + LS at 25°C
- High current capacity per bridge
 - **DRV8889/A-Q1**: 2.4-A peak, 1.5-A full-scale
 - **DRV8899-Q1**: 1.7-A peak, 1-A full-scale
- TRQ_DAC bits to scale full-scale current
- Configurable off-time PWM chopping
- Simple STEP/DIR interface
- SPI with daisy chain support
- Low-current sleep mode (2 μ A)
- Programmable output slew rate
- Spread spectrum clocking to minimize EMI
- Protection features
 - VM undervoltage lockout
 - Overcurrent protection
 - Open load detection
 - Overtemperature warning and shutdown
 - Undertemperature warning
 - Fault condition indication pin (nFAULT)
- **Functional Safety-Capable**
 - [Documentation available to aid functional safety system design](#)

2 Applications

- [Automotive bipolar stepper motors](#)
- [Headlight position adjustment](#)
- [Head-up display \(HUD\)](#)
- [HVAC stepper motors](#)
- [Electronic fuel injection \(EFI\)](#)

3 Description

The DRV8899-Q1 is a fully integrated stepper motor driver, supporting up to 1 A full scale current with an internal microstepping indexer, smart tune decay technology, and integrated current sensing. With a simple step/dir interface to manage the direction and step rate, DRV8899-Q1 supports up to 1/256 levels of microstepping to enable a smooth motion profile. Integrated current sensing eliminates the need

for two external resistors, saving board space and cost. DRV8899-Q1 provides 8 decay mode options including: smart tune, slow, and mixed decay options. Smart tune automatically adjusts for optimal current regulation performance and compensates for any motor variation and aging effects. The device also includes an integrated torque DAC which allows for the controller to scale the output current through SPI without needing to scale the VREF voltage reference. A low-power sleep mode is provided for very low standby current using an nSLEEP pin. The device features full duplex, 4-wire synchronous SPI communication, with daisy chain support for up to 63 devices connected in series, for configurability and detailed fault reporting. View our full portfolio of [stepper motor drivers](#) on ti.com.

Device Information

| PART NUMBER (1) | PACKAGE | BODY SIZE (NOM) |
|-----------------|-------------------------------|-------------------|
| DRV8899QWRGERQ1 | VQFN (24) (Wettable Flank) | 4.00 mm × 4.00 mm |

(1) For all available packages, see the orderable addendum at the end of the data sheet.

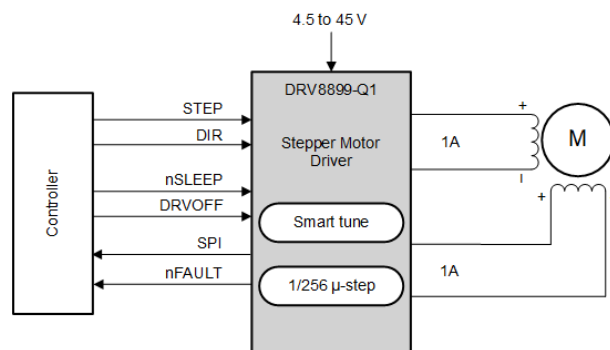

Simplified Schematic



Table of Contents

| | | | |
|--|----|--|----|
| 1 Features | 1 | 7.5 Programming..... | 36 |
| 2 Applications | 1 | 7.6 Register Maps..... | 41 |
| 3 Description | 1 | 8 Application and Implementation | 49 |
| 4 Revision History | 2 | 8.1 Application Information..... | 49 |
| 5 Pin Configuration and Functions | 3 | 8.2 Typical Application..... | 49 |
| Pin Functions..... | 3 | 9 Power Supply Recommendations | 59 |
| 6 Specifications | 5 | 9.1 Bulk Capacitance..... | 59 |
| 6.1 Absolute Maximum Ratings..... | 5 | 10 Layout | 60 |
| 6.2 ESD Ratings..... | 5 | 10.1 Layout Guidelines..... | 60 |
| 6.3 Recommended Operating Conditions..... | 6 | 10.2 Layout Example..... | 61 |
| 6.4 Thermal Information..... | 6 | 11 Device and Documentation Support | 62 |
| 6.5 Electrical Characteristics..... | 7 | 11.1 Documentation Support..... | 62 |
| 6.6 SPI Timing Requirements..... | 8 | 11.2 Receiving Notification of Documentation Updates.. | 62 |
| 6.7 Indexer Timing Requirements..... | 10 | 11.3 Support Resources..... | 62 |
| 6.8 Typical Characteristics..... | 11 | 11.4 Trademarks..... | 62 |
| 7 Detailed Description | 12 | 11.5 Electrostatic Discharge Caution..... | 62 |
| 7.1 Overview..... | 12 | 11.6 Glossary..... | 62 |
| 7.2 Functional Block Diagram..... | 13 | 12 Mechanical, Packaging, and Orderable | |
| 7.3 Feature Description..... | 14 | Information | 62 |
| 7.4 Device Functional Modes..... | 35 | | |

4 Revision History

NOTE: Page numbers for previous revisions may differ from page numbers in the current version.

| Changes from Revision A (August 2020) to Revision B (April 2021) | Page |
|---|-------------|
| • Added Functional Safety information | 1 |
| • Fixed typo in Absolute Maximum Ratings table..... | 5 |
| • Updated <i>Full Step with 100% Current</i> table..... | 15 |
| • Removed duplicate package drawings..... | 62 |

| Changes from Revision * (November 2019) to Revision A (August 2020) | Page |
|--|-------------|
| • Changed Device status to Production Data | 1 |

5 Pin Configuration and Functions

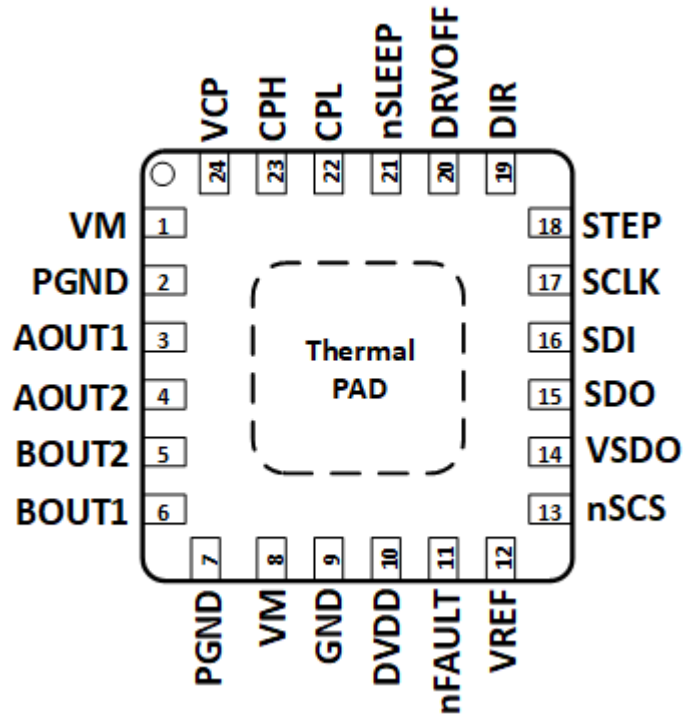

Figure 5-1. WRGE Package 24-Pin VQFN With Exposed Thermal Pad Top View

Pin Functions

| PIN | | I/O | TYPE | DESCRIPTION |
|--------|------|-----|-----------|---|
| NAME | NO. | | | |
| AOUT1 | 3 | O | Output | Winding A output. Connect to stepper motor winding. |
| AOUT2 | 4 | O | Output | Winding A output. Connect to stepper motor winding. |
| PGND | 2, 7 | — | Power | Power ground. Both PGND pins are shorted internally. Connect to system ground on PCB. |
| BOUT1 | 6 | O | Output | Winding B output. Connect to stepper motor winding |
| BOUT2 | 5 | O | Output | Winding B output. Connect to stepper motor winding |
| CPH | 23 | — | Power | Charge pump switching node. Connect a X7R, 0.022- μ F, VM-rated ceramic capacitor from CPH to CPL. |
| CPL | 22 | | | |
| DIR | 19 | I | Input | Direction input. Logic level sets the direction of stepping; internal pulldown resistor. |
| DRVOFF | 20 | I | Input | Logic high to disable device outputs; logic low to enable; internal pullup to DVDD. |
| DVDD | 10 | | Power | Logic supply voltage. Connect a X7R, 0.47- μ F, 6.3-V or 10-V rated ceramic capacitor to GND. |
| GND | 9 | — | Power | Device ground. Connect to system ground. |
| VREF | 12 | I | Input | Current set reference input. Maximum value 2.2 V. DVDD can be used to provide VREF through a resistor divider. |
| SCLK | 17 | I | Input | Serial clock input. Serial data is shifted out and captured on the corresponding rising and falling edge on this pin. |
| SDI | 16 | I | Input | Serial data input. Data is captured on the falling edge of the SCLK pin |
| SDO | 15 | O | Push Pull | Serial data output. Data is shifted out on the rising edge of the SCLK pin. |

| PIN | | I/O | TYPE | DESCRIPTION |
|--------|------|-----|------------|--|
| NAME | NO. | | | |
| STEP | 18 | I | Input | Step input. A rising edge causes the indexer to advance one step; internal pulldown resistor. |
| VCP | 24 | — | Power | Charge pump output. Connect a X7R, 0.22- μ F, 16-V ceramic capacitor to VM. |
| VM | 1, 8 | — | Power | Power supply. Connect to motor supply voltage and bypass to GND with two 0.01- μ F ceramic capacitors (one for each pin) plus a bulk capacitor rated for VM. |
| VSDO | 14 | | Power | Supply pin for SDO output. Connect to 5-V or 3.3-V depending on the desired logic level. |
| nFAULT | 11 | O | Open Drain | Fault indication. Pulled logic low with fault condition; open-drain output requires an external pullup resistor. |
| nSCS | 13 | I | Input | Serial chip select. An active low on this pin enables the serial interface communications. Internal pullup to DVDD. |
| nSLEEP | 21 | I | Input | Sleep mode input. Logic high to enable device; logic low to enter low-power sleep mode; internal pulldown resistor. |
| PAD | - | - | - | Thermal pad. Connect to system ground. |

6 Specifications

6.1 Absolute Maximum Ratings

over operating free-air temperature range (unless otherwise noted) 1

| | MIN | MAX | UNIT |
|---|--------------------|----------|------|
| Power supply voltage (VM) | -0.3 | 50 | V |
| Charge pump voltage (VCP, CPH) | -0.3 | VM + 7 | V |
| Charge pump negative switching pin (CPL) | -0.3 | VM | V |
| nSLEEP pin (nSLEEP) | -0.3 | VM | V |
| Internal regulator voltage (DVDD) | -0.3 | 5.75 | V |
| SDO output reference voltage (VSDO) | -0.3 | 5.75 | V |
| Control pin voltage (STEP, DIR, DRVOFF, nFAULT, SDI, SDO, SCLK, nSCS) | -0.3 | 5.75 | V |
| Open drain output current (nFAULT) | 0 | 10 | mA |
| Reference input pin voltage (VREF) | -0.3 | 5.75 | V |
| Continuous phase node pin voltage (AOUT1, AOUT2, BOUT1, BOUT2) | -1.0 | VM + 1.0 | V |
| Transient 100 ns phase node pin voltage (AOUT1, AOUT2, BOUT1, BOUT2) | -3.0 | VM + 3.0 | V |
| Peak drive current (AOUT1, AOUT2, BOUT1, BOUT2) | Internally Limited | | A |
| Operating ambient temperature, T _A | -40 | 125 | °C |
| Operating junction temperature, T _J | -40 | 150 | °C |
| Storage temperature, T _{stg} | -65 | 150 | °C |

- Stresses beyond those listed under *Absolute Maximum Ratings* may cause permanent damage to the device. These are stress ratings only, which do not imply functional operation of the device at these or any other conditions beyond those indicated under *Recommended Operating Conditions*. Exposure to absolute-maximum-rated conditions for extended periods may affect device reliability.

6.2 ESD Ratings

| | | VALUE | UNIT |
|--------------------|-------------------------|--|------|
| V _(ESD) | Electrostatic discharge | Human body model (HBM), per AEC Q100-002 (1) | V |
| | | Charged device model (CDM), per AEC Q100-011 | |

- AECQ100-002 indicates that HBM stressing shall be in accordance with the ANSI/ESDA/JEDEC JS-001 specification.

6.3 Recommended Operating Conditions

over operating free-air temperature range (unless otherwise noted) 1

| | | MIN | MAX | UNIT |
|------------|--|------|---------|------|
| V_{VM} | Supply voltage range for normal (DC) operation | 4.5 | 45 | V |
| V_I | Logic level input voltage | 0 | 5.5 | V |
| V_{SDO} | SDO buffer supply voltage | 2.9 | 5.5 | V |
| V_{VREF} | VREF voltage | 0.05 | 2.2 | V |
| f_{STEP} | Applied STEP signal (STEP) | 0 | 100 (2) | kHz |
| I_{FS} | Motor full-scale current (xOUTx) | 0 | 1 (3) | A |
| I_{rms} | Motor RMS current (xOUTx) | 0 | 0.7 (3) | A |
| T_A | Operating ambient temperature | -40 | 125 | °C |
| T_J | Operating junction temperature | -40 | 150 | °C |

6.4 Thermal Information

| THERMAL METRIC 1 | | DRV8899-Q1 | UNIT |
|----------------------|--|------------|------|
| | | RGE (VQFN) | |
| | | 24 PINS | |
| $R_{\theta JA}$ | Junction-to-ambient thermal resistance | 40.7 | °C/W |
| $R_{\theta JC(top)}$ | Junction-to-case (top) thermal resistance | 31.1 | °C/W |
| $R_{\theta JB}$ | Junction-to-board thermal resistance | 17.9 | °C/W |
| ψ_{JT} | Junction-to-top characterization parameter | 0.6 | °C/W |
| ψ_{JB} | Junction-to-board characterization parameter | 17.8 | °C/W |
| $R_{\theta JC(bot)}$ | Junction-to-case (bottom) thermal resistance | 4.3 | °C/W |

- For more information about traditional and new thermalmetrics, see the [Semiconductor and IC Package Thermal Metrics application report](#)

6.5 Electrical Characteristics

Over recommended operating conditions unless otherwise noted. Typical limits apply for $T_J = 25^\circ\text{C}$ and $V_{VM} = 13.5\text{ V}$

| PARAMETER | | TEST CONDITIONS | MIN | TYP | MAX | UNIT |
|--|---------------------------------|---|-----|--------|-----|---------------|
| POWER SUPPLIES (VM, DVDD, VSDO) | | | | | | |
| I_{VM} | VM operating supply current | DRVOFF = 0, nSLEEP = 1, No output | | 5 | 7 | mA |
| I_{VMQ} | VM sleep mode supply current | nSLEEP = 0 | | 2 | 4 | μA |
| t_{SLEEP} | Sleep time | nSLEEP = 0 to sleep-mode | 75 | | | μs |
| t_{RESET} | nSLEEP reset pulse | nSLEEP low to only clear fault registers | 18 | | 35 | μs |
| t_{WAKE} | Wake-up time | nSLEEP = 1 to output transition | | 0.6 | 0.9 | ms |
| t_{ON} | Turn-on time | VM > UVLO to output transition | | 0.6 | 0.9 | ms |
| V_{DVDD} | Internal regulator voltage | No external load, $6\text{ V} < V_{VM} < 45\text{ V}$ | 4.5 | 5 | 5.5 | V |
| CHARGE PUMP (VCP, CPH, CPL) | | | | | | |
| V_{VCP} | VCP operating voltage | | | VM + 5 | | V |
| $f_{(VCP)}$ | Charge pump switching frequency | $V_{VM} > UVLO$; nSLEEP = 1 | | 400 | | kHz |
| LOGIC-LEVEL INPUTS (STEP, DIR, nSLEEP, nSCS, SCLK, SDI, DRVOFF) | | | | | | |
| V_{IL} | Input logic-low voltage | | 0 | | 0.6 | V |
| V_{IH} | Input logic-high voltage | | 1.5 | | 5.5 | V |
| V_{HYS} | Input logic hysteresis | | | 150 | | mV |
| I_{IL1} | Input logic-low current | $V_{IN} = 0\text{ V}$ (nSCS, DRVOFF) | 8 | | 12 | μA |
| I_{IL2} | Input logic-low current | $V_{IN} = 0\text{ V}$ | -1 | | 1 | μA |
| I_{IH1} | Input logic-high current | $V_{IN} = DVDD$ (nSCS, DRVOFF) | | | 500 | nA |
| I_{IH2} | Input logic-high current | $V_{IN} = 5\text{ V}$ | | | 50 | μA |
| PUSH-PULL OUTPUT (SDO) | | | | | | |
| $R_{PD,SDO}$ | Internal pull-down resistance | 5mA load, with respect to GND | | 40 | 75 | Ω |
| $R_{PU,SDO}$ | Internal pull-up resistance | 5mA load, with respect to VSDO | | 30 | 60 | Ω |
| I_{SDO} | SDO Leakage Current | SDO = VSDO and 0V | -1 | | 1 | μA |
| CONTROL OUTPUTS (nFAULT) | | | | | | |
| V_{OL} | Output logic-low voltage | $I_O = 5\text{ mA}$ | | | 0.4 | V |
| I_{OH} | Output logic-high leakage | $V_{VM} = 13.5\text{ V}$ | -1 | | 1 | μA |

Over recommended operating conditions unless otherwise noted. Typical limits apply for $T_J = 25^\circ\text{C}$ and $V_{VM} = 13.5\text{ V}$

| PARAMETER | | TEST CONDITIONS | MIN | TYP | MAX | UNIT |
|--|-------------------------------------|--|------|--------|------|------------------|
| MOTOR DRIVER OUTPUTS (AOUT1, AOUT2, BOUT1, BOUT2) | | | | | | |
| $R_{DS(ONH)}$ | High-side FET on resistance | $T_J = 25^\circ\text{C}, I_O = -1\text{ A}$ | | 600 | 730 | m Ω |
| | | $T_J = 125^\circ\text{C}, I_O = -1\text{ A}$ | | 900 | 1100 | m Ω |
| | | $T_J = 150^\circ\text{C}, I_O = -1\text{ A}$ | | 1040 | 1250 | m Ω |
| $R_{DS(ONL)}$ | Low-side FET on resistance | $T_J = 25^\circ\text{C}, I_O = -1\text{ A}$ | | 600 | 730 | m Ω |
| | | $T_J = 125^\circ\text{C}, I_O = -1\text{ A}$ | | 900 | 1100 | m Ω |
| | | $T_J = 150^\circ\text{C}, I_O = -1\text{ A}$ | | 1040 | 1250 | m Ω |
| t_{SR} | Output slew rate | SR = 00b, VM = 13.5 V, $I_O = 0.5\text{ A}$ | | 10 | | V/ μs |
| | | SR = 01b, VM = 13.5 V, $I_O = 0.5\text{ A}$ | | 35 | | |
| | | SR = 10b, VM = 13.5 V, $I_O = 0.5\text{ A}$ | | 50 | | |
| | | SR = 11b, VM = 13.5 V, $I_O = 0.5\text{ A}$ | | 105 | | |
| PWM CURRENT CONTROL (VREF) | | | | | | |
| K_V | Transimpedance gain | | | 2.2 | | V/A |
| t_{OFF} | PWM off-time | TOFF = 00b | | 7 | | μs |
| | | TOFF = 01b | | 16 | | |
| | | TOFF = 10b | | 24 | | |
| | | TOFF = 11b | | 32 | | |
| ΔI_{TRIP} | Current trip accuracy | $I_O = 1\text{ A}, 10\%$ to 30% current setting | -13 | | 10 | % |
| | | $I_O = 1\text{ A}, 30\%$ to 100% current setting | -8 | | 8 | |
| $I_{O,CH}$ | AOUT and BOUT current matching | $I_O = 1\text{ A}$ | -2.5 | | 2.5 | % |
| PROTECTION CIRCUITS | | | | | | |
| V_{UVLO} | VM UVLO lockout | VM falling, UVLO falling | 4.15 | 4.25 | 4.35 | V |
| | | VM rising, UVLO rising | 4.25 | 4.35 | 4.45 | |
| $V_{UVLO,HYS}$ | Undervoltage hysteresis | Rising to falling threshold | | 100 | | mV |
| V_{RST} | VM UVLO reset | VM falling, device reset, no SPI communications | | | 3.9 | V |
| V_{CPUV} | Charge pump undervoltage | VCP falling; CPUV report | | VM + 2 | | V |
| I_{OCP} | Overcurrent protection | Current through any FET | 1.7 | | | A |
| t_{OCP} | Overcurrent deglitch time | $V_{VM} < 37\text{ V}$ | | 3 | | μs |
| | | $V_{VM} \geq 37\text{ V}$ | | 0.5 | | |
| t_{RETRY} | Overcurrent retry time | OCP_MODE = 1b | | 4 | | ms |
| t_{OL} | Open load detection time | EN_OL = 1b | | | 200 | ms |
| I_{OL} | Open load current threshold | | | 30 | | mA |
| T_{OTW} | Overtemperature warning | Die temperature T_J | 135 | 150 | 165 | $^\circ\text{C}$ |
| T_{UTW} | Undertemperature warning | Die temperature T_J | -25 | -10 | 5 | $^\circ\text{C}$ |
| T_{OTSD} | Thermal shutdown | Die temperature T_J | 150 | 165 | 180 | $^\circ\text{C}$ |
| T_{HYS_OTSD} | Thermal shutdown hysteresis | Die temperature T_J | | 20 | | $^\circ\text{C}$ |
| T_{HYS_OTW} | Overtemperature warning hysteresis | Die temperature T_J | | 20 | | $^\circ\text{C}$ |
| T_{HYS_UTW} | Undertemperature warning hysteresis | Die temperature T_J | | 10 | | $^\circ\text{C}$ |

6.6 SPI Timing Requirements

| | | MIN | NOM | MAX | UNIT |
|---------------|---------------------------|-----|-----|-----|------|
| $t_{(READY)}$ | SPI ready, VM > V_{RST} | | 1 | | ms |

| | | MIN | NOM | MAX | UNIT |
|------------------|--|-----|-----|-----|---------|
| $t_{(CLK)}$ | SCLK minimum period | 100 | | | ns |
| $t_{(CLKH)}$ | SCLK minimum high time | 50 | | | ns |
| $t_{(CLKL)}$ | SCLK minimum low time | 50 | | | ns |
| $t_{su(SDI)}$ | SDI input setup time | 20 | | | ns |
| $t_{h(SDI)}$ | SDI input hold time | 30 | | | ns |
| $t_{d(SDO)}$ | SDO output delay time, SCLK high to SDO valid, $C_L = 20$ pF | | | 30 | ns |
| $t_{su(nSCS)}$ | nSCS input setup time | 50 | | | ns |
| $t_{h(nSCS)}$ | nSCS input hold time | 50 | | | ns |
| $t_{(HI_nSCS)}$ | nSCS minimum high time before active low | | | 2 | μ s |
| $t_{dis(nSCS)}$ | nSCS disable time, nSCS high to SDO high impedance | | 10 | | ns |

6.7 Indexer Timing Requirements

Over recommended operating conditions unless otherwise noted. Typical limits apply for $T_J = 25^\circ\text{C}$ and $V_{VM} = 13.5\text{ V}$

| NO. | | | MIN | MAX | UNIT |
|-----|--------------------------|--------------------------------|-----|--------------------|------|
| 1 | f_{STEP} | Step frequency | | 500 ⁽¹⁾ | kHz |
| 2 | $t_{\text{WH(STEP)}}$ | Pulse duration, STEP high | 970 | | ns |
| 3 | $t_{\text{WL(STEP)}}$ | Pulse duration, STEP low | 970 | | ns |
| 4 | $t_{\text{SU(DIR, Mx)}}$ | Setup time, DIR to STEP rising | 200 | | ns |
| 5 | $t_{\text{H(DIR, Mx)}}$ | Hold time, DIR to STEP rising | 200 | | ns |

(1) STEP input can operate up to 500 kHz, but system bandwidth is limited by the motor load.

6.8 Typical Characteristics

Over recommended operating conditions (unless otherwise noted)

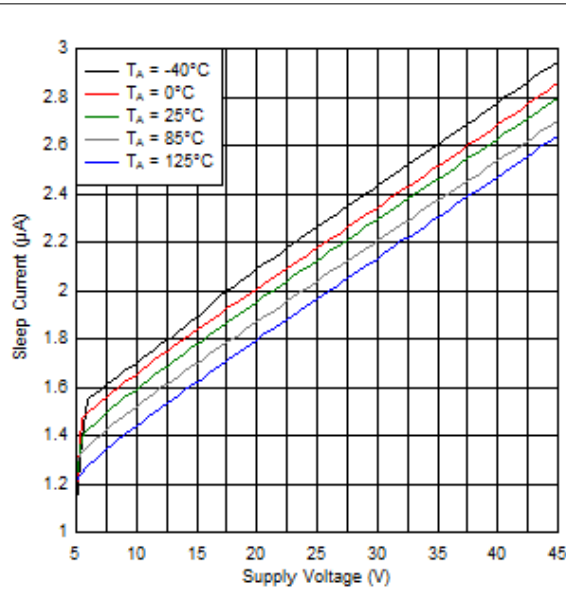

Figure 6-1. Sleep Current over VM

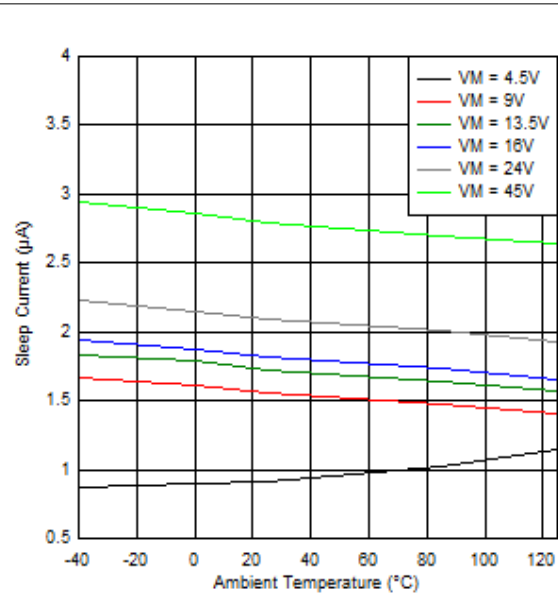

Figure 6-2. Sleep Current over Temperature

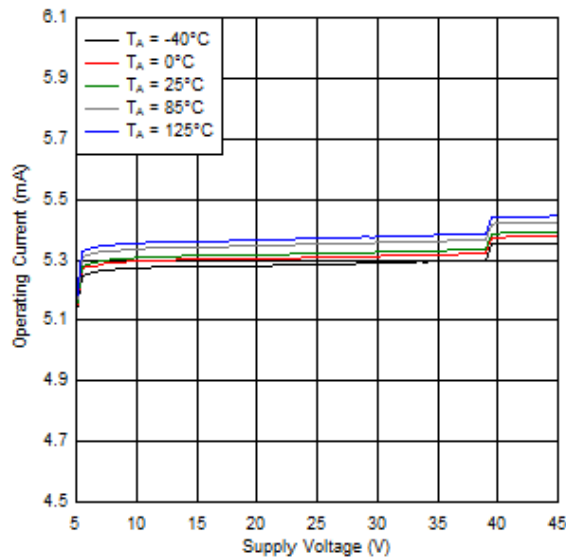

Figure 6-3. Operating Current over VM

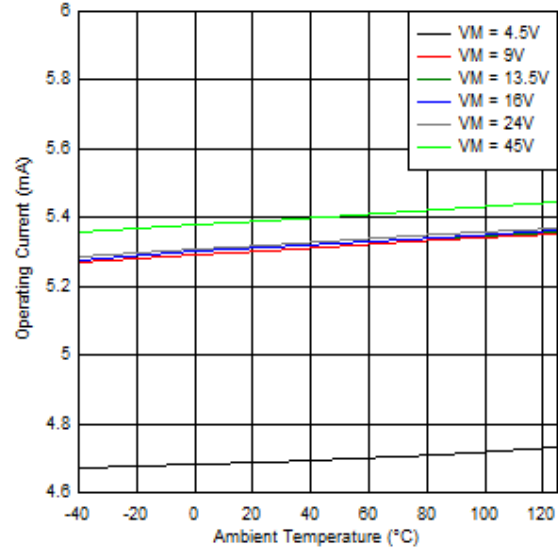

Figure 6-4. Operating Current over Temperature

7 Detailed Description

7.1 Overview

The DRV8899-Q1 device is an integrated motor-driver solution for bipolar stepper motors. The device integrates two N-channel power MOSFET H-bridges, integrated current sense and regulation circuitry, and a microstepping indexer. The DRV8899-Q1 device can be powered with a supply voltage from 4.5 to 45 V and is capable of providing an output current up to 1.7-A peak, 1-A full-scale, or 0.7-A root mean square (rms). The actual full-scale and rms current depends on the ambient temperature, supply voltage, and PCB thermal capability.

The device uses an integrated current-sense architecture which eliminates the need for two external power sense resistors. This architecture removes the power dissipated in the sense resistors by using a current mirror approach and using the internal power MOSFETs for current sensing. The current regulation set point is adjusted by the voltage at the VREF pin. These features reduces external component cost, board PCB size, and system power consumption.

A simple STEP/DIR interface allows for an external controller to manage the direction and step rate of the stepper motor. The internal indexer can execute high-accuracy microstepping without requiring the external controller to manage the winding current level. The indexer is capable of full step, half step, and 1/4, 1/8, 1/16, 1/32, 1/64, 1/128 and 1/256 microstepping. In addition to a standard half stepping mode, a noncircular half stepping mode is available for increased torque output at higher motor RPM.

The current regulation is configurable between several decay modes. The decay mode can be selected as a slow-mixed, mixed decay, smart tune Ripple Control, or smart tune Dynamic Decay current regulation scheme. The slow-mixed decay mode uses slow decay on increasing steps and mixed decay on decreasing steps. The smart tune decay modes automatically adjust for optimal current regulation performance and compensate for motor variation and aging effects. Smart tune Ripple Control uses a variable off-time, ripple control scheme to minimize distortion of the motor winding current. Smart tune Dynamic Decay uses a fixed off-time, dynamic decay percentage scheme to minimize distortion of the motor winding current while also minimizing frequency content.

The device integrates a spread spectrum clocking feature for both the internal digital oscillator and internal charge pump. This feature combined with output slew rate control minimizes the radiated emissions from the device.

A torque DAC feature allows the controller to scale the output current without needing to scale the VREF voltage reference. The torque DAC is accessed using a digital input pin which allows the controller to save system power by decreasing the motor current consumption when high output torque is not required.

A low-power sleep mode is included which allows the system to save power when not actively driving the motor.

7.2 Functional Block Diagram

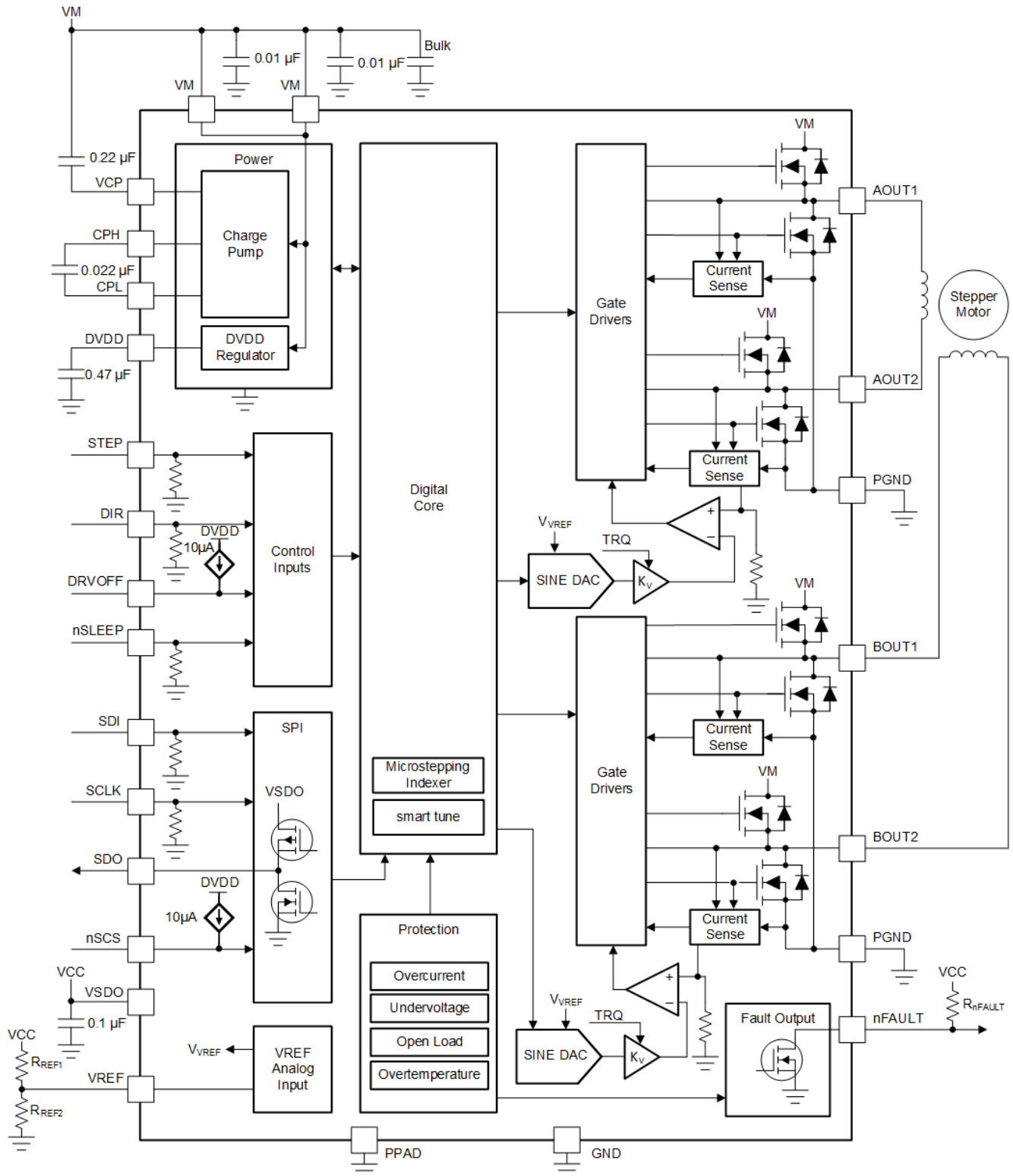

7.3 Feature Description

Table 7-1 lists the recommended external components for the DRV8899-Q1 device.

Table 7-1. DRV8899-Q1 External Components

| COMPONENT | PIN 1 | PIN 2 | RECOMMENDED |
|------------------------------|--------------------|--------|---|
| C _{VM1} | VM | GND | Two X7R, 0.01- μ F, VM-rated ceramic capacitors |
| C _{VM2} | VM | GND | Bulk, VM-rated capacitor |
| C _{VCP} | VCP | VM | X7R, 0.22- μ F, 16-V ceramic capacitor |
| C _{SW} | CPH | CPL | X7R, 0.022- μ F, VM-rated ceramic capacitor |
| C _{DVDD} | DVDD | GND | X7R, 0.47- μ F to 1- μ F, 6.3-V ceramic capacitor |
| R _{nFAULT} | VCC ⁽¹⁾ | nFAULT | >4.7-k Ω resistor |
| R _{REF1} | VREF | VCC | Resistor to limit chopping current. It is recommended that the value of parallel combination of R _{REF1} and R _{REF2} should be less than 50-k Ω . |
| R _{REF2} (Optional) | VREF | GND | |

(1) VCC is not a pin on the DRV8899-Q1 device, but a VCC supply voltage pullup is required for open-drain output nFAULT; nFAULT may be pulled up to DVDD

7.3.1 Stepper Motor Driver Current Ratings

Stepper motor drivers can be classified using three different numbers to describe the output current: peak, rms, and full-scale.

7.3.1.1 Peak Current Rating

The peak current in a stepper driver is limited by the overcurrent protection trip threshold I_{OCP}. The peak current describes any transient duration current pulse, for example when charging capacitance, when the overall duty cycle is very low. In general the minimum value of I_{OCP} specifies the peak current rating of the stepper motor driver.

For the DRV8899-Q1 device, the peak current rating is 1.7 A per bridge.

7.3.1.2 rms Current Rating

The rms (average) current is determined by the thermal considerations of the IC. The rms current is calculated based on the R_{DS(ON)}, rise and fall time, PWM frequency, device quiescent current, and package thermal performance in a typical system at 25°C. The actual operating rms current may be higher or lower depending on heatsinking and ambient temperature.

For the DRV8899-Q1 device, the rms current rating is 0.7 A per bridge.

7.3.1.3 Full-Scale Current Rating

The full-scale current describes the top of the sinusoid current waveform while microstepping. Because the sinusoid amplitude is related to the rms current, the full-scale current is also determined by the thermal considerations of the device. The full-scale current rating is approximately $\sqrt{2} \times I_{RMS}$.

For the DRV8899-Q1 device, the full-scale current rating is 1 A per bridge.

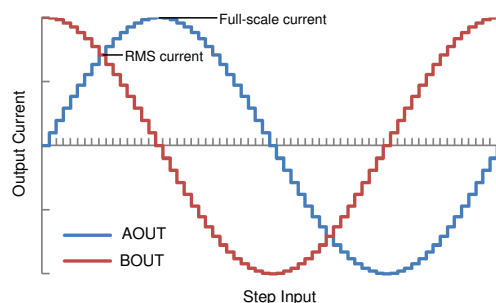

Figure 7-1. Full-Scale and RMS Current

7.3.2 PWM Motor Drivers

The device has drivers for two full H-bridges to drive the two windings of a bipolar stepper motor. Figure 7-2 shows a block diagram of the circuitry.

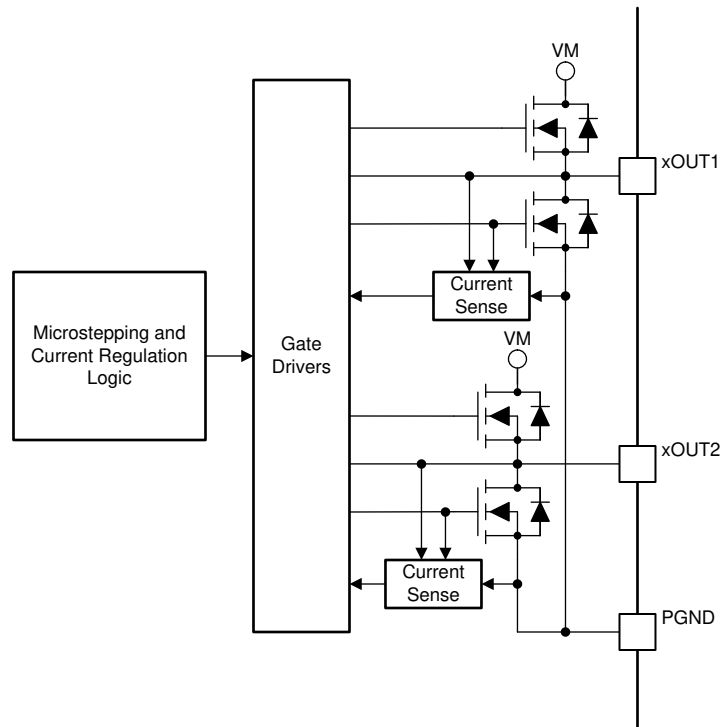

Figure 7-2. PWM Motor Driver Block Diagram

7.3.3 Microstepping Indexer

Built-in indexer logic in the device allows a number of different step modes. The MICROSTEP_MODE bits in the SPI register are used to configure the step mode as shown in Table 7-2.

Table 7-2. Microstepping Settings

| MICROSTEP_MODE | STEP MODE |
|----------------|--|
| 0000b | Full step (2-phase excitation) with 100% current |
| 0001b | Full step (2-phase excitation) with 71% current |
| 0010b | Non-circular 1/2 step |
| 0011b | 1/2 step |
| 0100b | 1/4 step |
| 0101b | 1/8 step |
| 0110b | 1/16 step |
| 0111b | 1/32 step |
| 1000b | 1/64 step |
| 1001b | 1/128 step |
| 1010b | 1/256 step |

Table 7-3 shows the relative current and step directions for full-step (71% current), 1/2 step, 1/4 step and 1/8 step operation. Higher microstepping resolutions follow the same pattern. The AOUT current is the sine of the electrical angle and the BOUT current is the cosine of the electrical angle. Positive current is defined as current flowing from the xOUT1 pin to the xOUT2 pin while driving.

At each rising edge of the STEP input the indexer travels to the next state in the table. The direction is shown with the DIR pin logic high. If the DIR pin is logic low, the sequence is reversed.

Note

If the step mode is changed on the fly while stepping, the indexer advances to the next valid state for the new step mode setting at the rising edge of STEP.

Note

While DIR = 0 and the electrical angle is at a full step angle (45, 135, 225, or 315 degrees), two rising edge pulses on the STEP pin are required in order to advance the indexer after changing from any microstep mode to the full step mode. The first pulse will induce no change in the electrical angle, the second pulse will move the indexer to the next full step angle.

The home state is an electrical angle of 45°. This state is entered after power-up, after exiting logic undervoltage lockout, or after exiting sleep mode.

Table 7-3. Relative Current and Step Directions

| 1/8 STEP | 1/4 STEP | 1/2 STEP | FULL STEP 71% | AOUT CURRENT (% FULL-SCALE) | BOUT CURRENT (% FULL-SCALE) | ELECTRICAL ANGLE (DEGREES) |
|----------|----------|----------|------------------|--------------------------------|--------------------------------|-------------------------------|
| 1 | 1 | 1 | | 0 | 100 | 0 |
| 2 | | | | 20 | 98 | 11 |
| 3 | 2 | | | 38 | 92 | 23 |
| 4 | | | | 56 | 83 | 34 |
| 5 | 3 | 2 | 1 | 71 | 71 | 45 |
| 6 | | | | 83 | 56 | 56 |
| 7 | 4 | | | 92 | 38 | 68 |
| 8 | | | | 98 | 20 | 79 |
| 9 | 5 | 3 | | 100 | 0 | 90 |
| 10 | | | | 98 | -20 | 101 |
| 11 | 6 | | | 92 | -38 | 113 |
| 12 | | | | 83 | -56 | 124 |
| 13 | 7 | 4 | 2 | 71 | -71 | 135 |
| 14 | | | | 56 | -83 | 146 |
| 15 | 8 | | | 38 | -92 | 158 |
| 16 | | | | 20 | -98 | 169 |
| 17 | 9 | 5 | | 0 | -100 | 180 |
| 18 | | | | -20 | -98 | 191 |
| 19 | 10 | | | -38 | -92 | 203 |
| 20 | | | | -56 | -83 | 214 |
| 21 | 11 | 6 | 3 | -71 | -71 | 225 |
| 22 | | | | -83 | -56 | 236 |
| 23 | 12 | | | -92 | -38 | 248 |
| 24 | | | | -98 | -20 | 259 |
| 25 | 13 | 7 | | -100 | 0 | 270 |
| 26 | | | | -98 | 20 | 281 |
| 27 | 14 | | | -92 | 38 | 293 |
| 28 | | | | -83 | 56 | 304 |
| 29 | 15 | 8 | 4 | -71 | 71 | 315 |

Table 7-3. Relative Current and Step Directions (continued)

| 1/8 STEP | 1/4 STEP | 1/2 STEP | FULL STEP 71% | AOUT CURRENT (% FULL-SCALE) | BOUT CURRENT (% FULL-SCALE) | ELECTRICAL ANGLE (DEGREES) |
|----------|----------|----------|------------------|--------------------------------|--------------------------------|-------------------------------|
| 30 | | | | -56 | 83 | 326 |
| 31 | 16 | | | -38 | 92 | 338 |
| 32 | | | | -20 | 98 | 349 |

Table 7-4 shows the full step operation with 100% full-scale current. This stepping mode consumes more power than full-step mode with 71% current, but provides a higher torque at high motor RPM.

Table 7-4. Full Step with 100% Current

| FULL STEP 100% | AOUT CURRENT (% FULL-SCALE) | BOUT CURRENT (% FULL-SCALE) | ELECTRICAL ANGLE (DEGREES) |
|-------------------|--------------------------------|--------------------------------|-------------------------------|
| 1 | 100 | 100 | 45 |
| 2 | 100 | -100 | 135 |
| 3 | -100 | -100 | 225 |
| 4 | -100 | 100 | 315 |

Table 7-5 shows the noncircular 1/2-step operation. This stepping mode consumes more power than circular 1/2-step operation, but provides a higher torque at high motor RPM.

Table 7-5. Non-Circular 1/2-Stepping Current

| NON-CIRCULAR 1/2-STEP | AOUT CURRENT (% FULL-SCALE) | BOUT CURRENT (% FULL-SCALE) | ELECTRICAL ANGLE (DEGREES) |
|-----------------------|--------------------------------|--------------------------------|-------------------------------|
| 1 | 0 | 100 | 0 |
| 2 | 100 | 100 | 45 |
| 3 | 100 | 0 | 90 |
| 4 | 100 | -100 | 135 |
| 5 | 0 | -100 | 180 |
| 6 | -100 | -100 | 225 |
| 7 | -100 | 0 | 270 |
| 8 | -100 | 100 | 315 |

7.3.4 Controlling VREF with an MCU DAC

In some cases, the full-scale output current may need to be changed between many different values, depending on motor speed and loading. The voltage of the VREF pin can be adjusted in the system to change the full-scale current.

In this mode of operation, as the DAC voltage increases, the full-scale regulation current increases as well. For proper operation, the output of the DAC should not rise above 2.2 V.

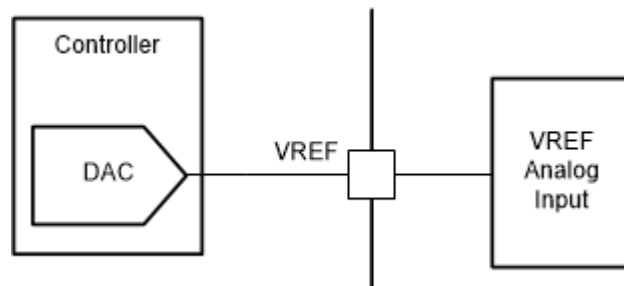

Figure 7-3. Controlling VREF with a DAC Resource

The VREF pin can also be adjusted using a PWM signal and low-pass filter. The R-C time constant for the low-pass filter should be longer than 10 times the period of the PWM signal.

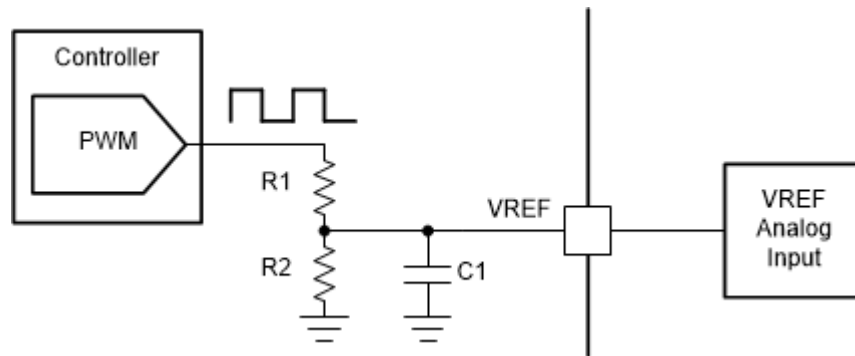

Figure 7-4. Controlling VREF With a PWM Resource

7.3.5 Current Regulation

The current through the motor windings is regulated by a PWM current-regulation circuit. When an H-bridge is enabled, current rises through the winding at a rate dependent on the DC voltage, inductance of the winding, and the magnitude of the back EMF present. When the current hits the current regulation threshold, the bridge enters a decay mode for a period of time determined by the TOFF register setting and the selected decay mode to decrease the current. After the off-time expires, the bridge is re-enabled, starting another PWM cycle.

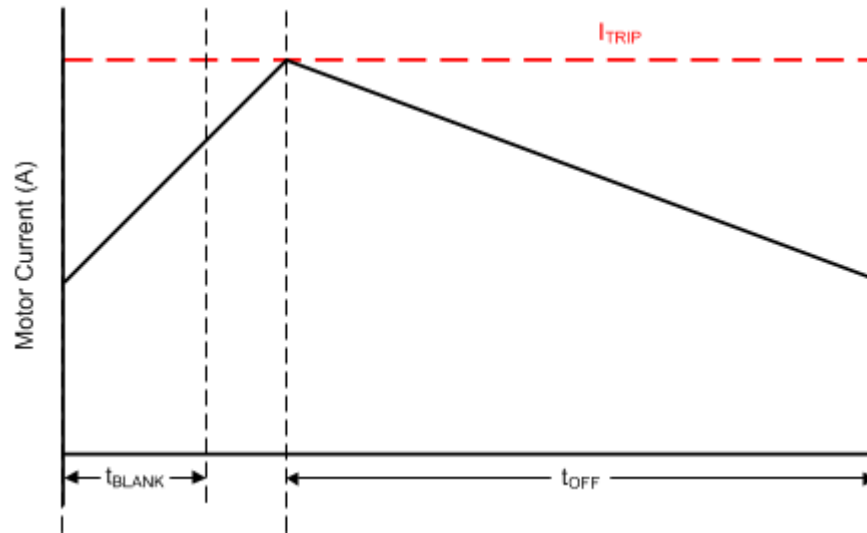

Figure 7-5. Current Chopping Waveform

The PWM regulation current is set by a comparator which monitors the voltage across the current sense MOSFETs in parallel with the low-side power MOSFETs. The current sense MOSFETs are biased with a reference current that is the output of a current-mode sine-weighted DAC whose full-scale reference current is set by the voltage at the VREF pin. In addition, the TRQ_DAC register can further scale the reference current.

Use Equation 1 to calculate the full-scale regulation current.

$$I_{FS} (A) = \frac{V_{REF} (V)}{K_V (V/A)} \times TRQ_DAC (\%) = \frac{V_{REF} (V) \times TRQ_DAC (\%)}{2.2 (V/A)} \quad (1)$$

The TRQ_DAC is adjusted via the SPI register. Table 7-6 lists the current scalar value for different inputs.

Table 7-6. Torque DAC Settings

| TRQ_DAC | CURRENT SCALAR (TRQ) |
|---------|----------------------|
| 0000b | 100% |
| 0001b | 93.75% |
| 0010b | 87.5% |
| 0011b | 81.25% |
| 0100b | 75% |
| 0101b | 68.75% |
| 0110b | 62.5 |
| 0111b | 56.25% |
| 1000b | 50% |
| 1001b | 43.75% |
| 1010b | 37.5% |

Table 7-6. Torque DAC Settings (continued)

| TRQ_DAC | CURRENT SCALAR (TRQ) |
|---------|----------------------|
| 1011b | 31.25% |
| 1100b | 25% |
| 1101b | 18.75% |
| 1110b | 12.5% |
| 1111b | 6.25% |

7.3.6 Decay Modes

During PWM current chopping, the H-bridge is enabled to drive through the motor winding until the PWM current chopping threshold is reached. This is shown in Figure 7-6, Item 1.

Once the chopping current threshold is reached, the H-bridge can operate in two different states, fast decay or slow decay. In fast decay mode, once the PWM chopping current level has been reached, the H-bridge reverses state to allow winding current to flow in a reverse direction. The opposite FETs are turned on; as the winding current approaches zero, the bridge is disabled to prevent any reverse current flow. Fast decay mode is shown in Figure 7-6, item 2. In slow decay mode, winding current is re-circulated by enabling both of the low-side FETs in the bridge. This is shown in Figure 7-6, Item 3.

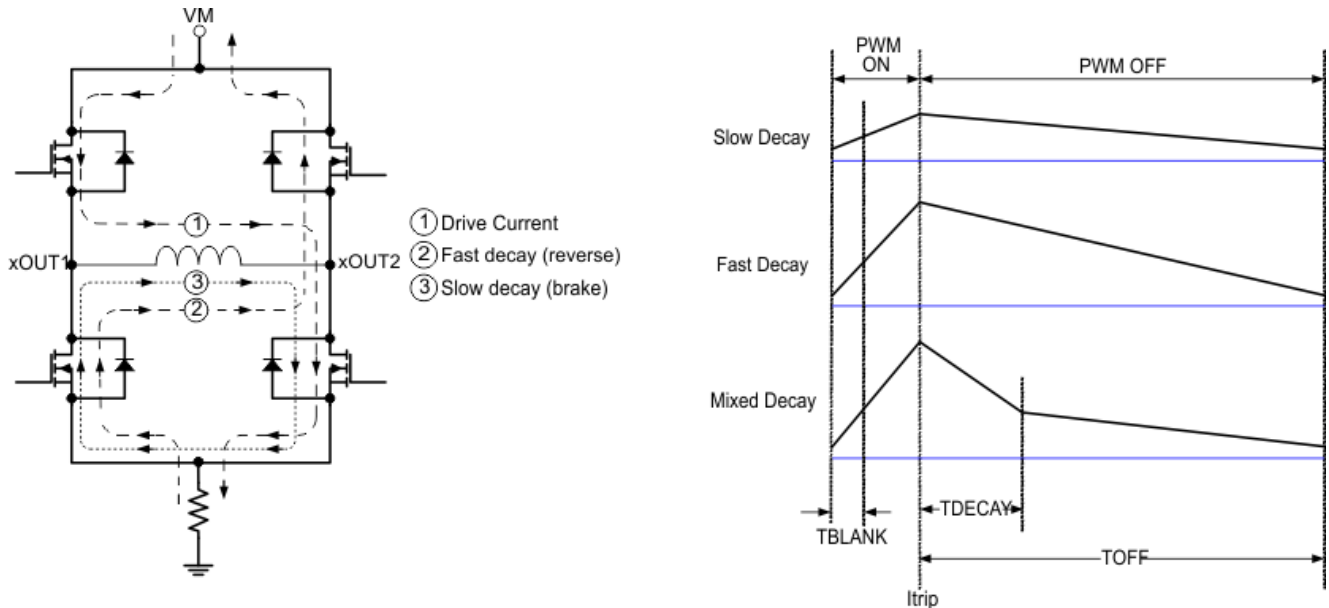

Figure 7-6. Decay Modes

The decay mode is selected by the DECAY register as shown in Table 7-7.

Table 7-7. Decay Mode Settings

| DECAY | INCREASING STEPS | DECREASING STEPS |
|----------------|---------------------------|---------------------------|
| 000b | Slow decay | Slow decay |
| 001b | Slow decay | Mixed decay: 30% fast |
| 010b | Slow decay | Mixed decay: 60% fast |
| 011b | Slow decay | Fast decay |
| 100b | Mixed decay: 30% fast | Mixed decay: 30% fast |
| 101b | Mixed decay: 60% fast | Mixed decay: 60% fast |
| 110b | Smart tune Dynamic Decay | Smart tune Dynamic Decay |
| 111b (default) | Smart tune Ripple Control | Smart tune Ripple Control |

Figure 7-7 defines increasing and decreasing current. For the slow-mixed decay mode, the decay mode is set as slow during increasing current steps and mixed decay during decreasing current steps. In full step and noncircular 1/2-step operation, the decay mode corresponding to decreasing steps is always used.

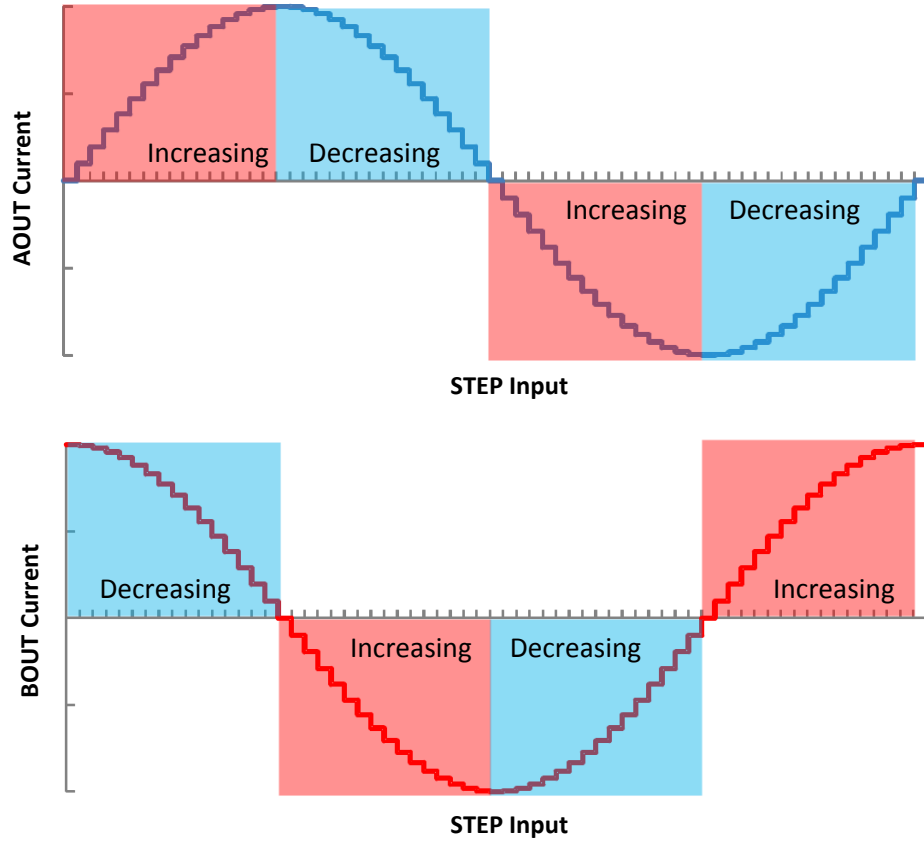

Figure 7-7. Definition of Increasing and Decreasing Steps

7.3.6.1 Slow Decay for Increasing and Decreasing Current

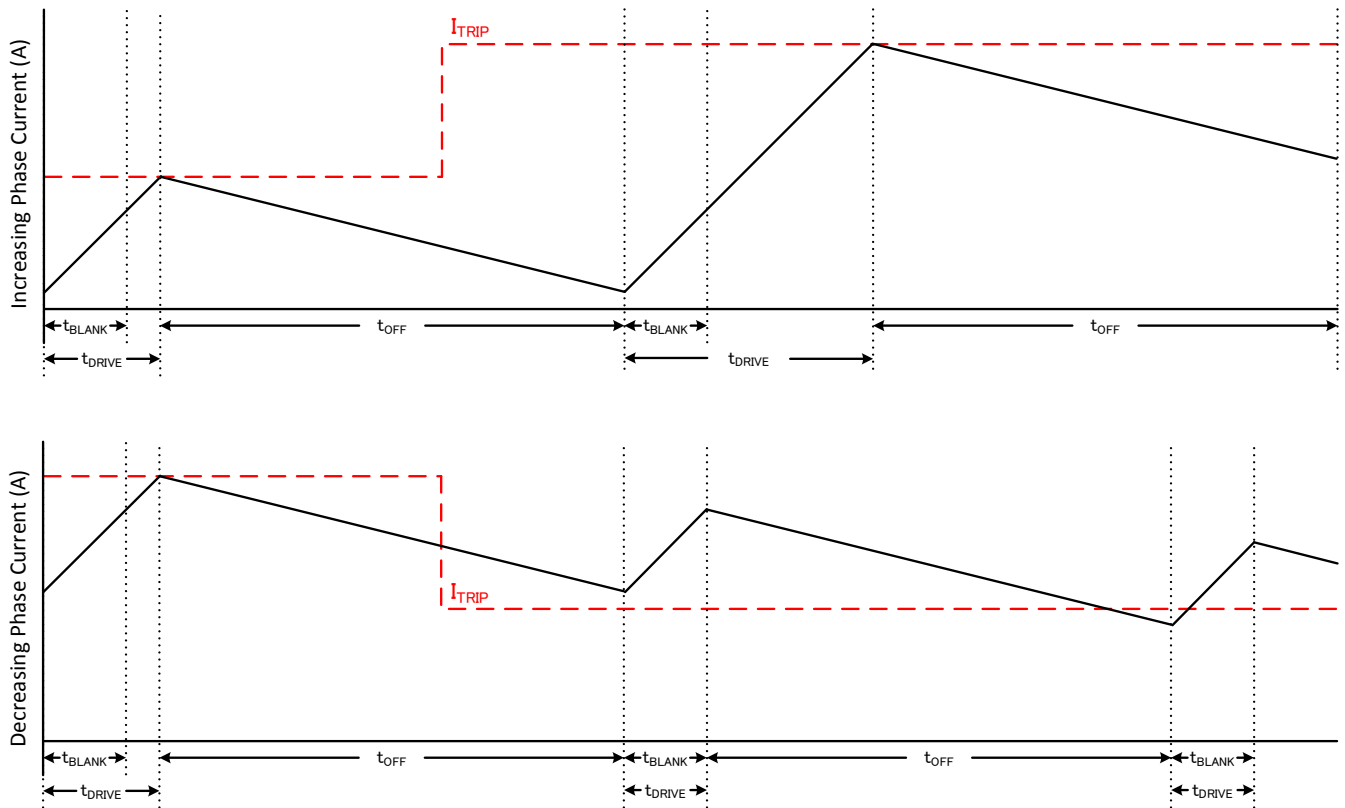

Figure 7-8. Slow/Slow Decay Mode

During slow decay, both of the low-side FETs of the H-bridge are turned on, allowing the current to be recirculated.

Slow decay exhibits the least current ripple of the decay modes for a given t_{OFF} . However on decreasing current steps, slow decay will take a long time to settle to the new I_{TRIP} level because the current decreases very slowly. If the current at the end of the off time is above the I_{TRIP} level, slow decay will be extended for another off time duration and so on, till the current at the end of the off time is below I_{TRIP} level.

In cases where current is held for a long time (no input in the STEP pin) or at very low stepping speeds, slow decay may not properly regulate current because no back-EMF is present across the motor windings. In this state, motor current can rise very quickly, and may require a large off-time. In some cases this may cause a loss of current regulation, and a more aggressive decay mode is recommended.

7.3.6.2 Slow Decay for Increasing Current, Mixed Decay for Decreasing Current

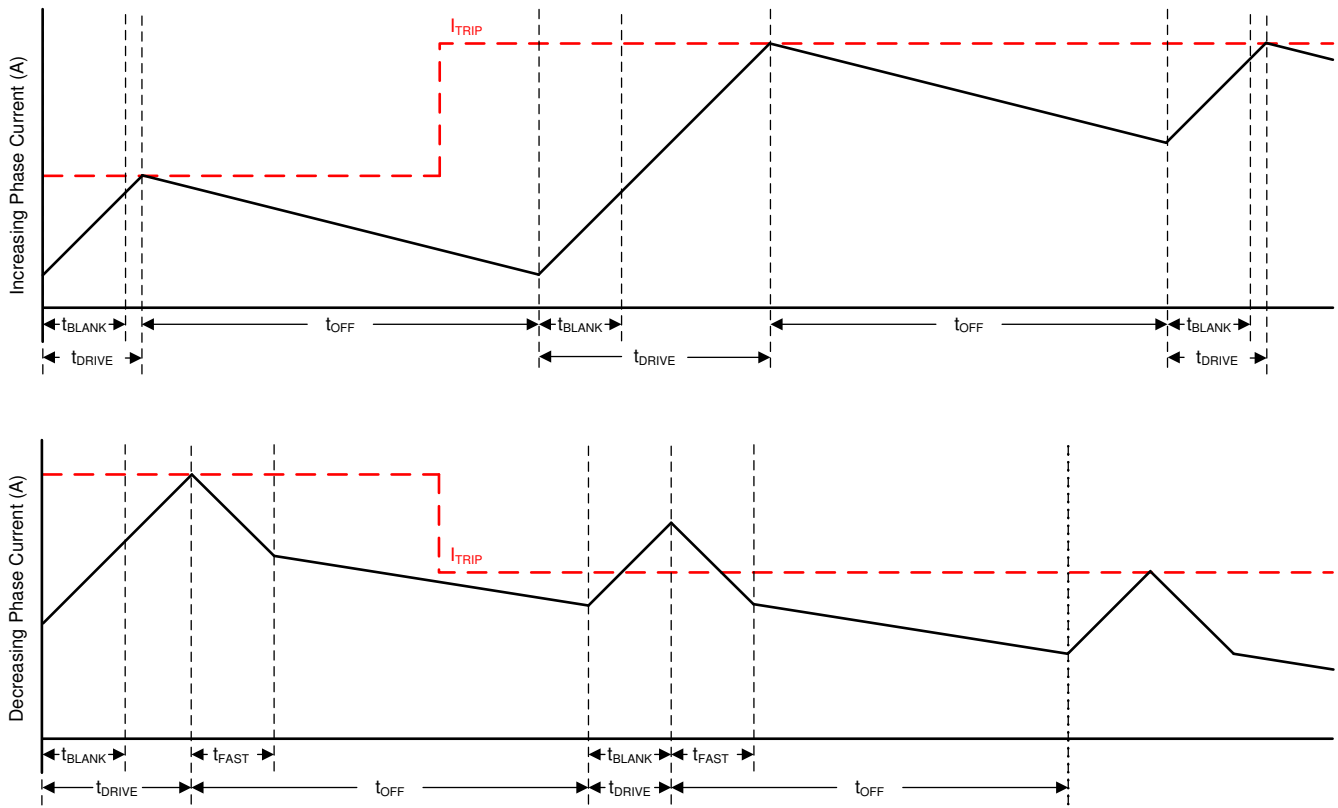
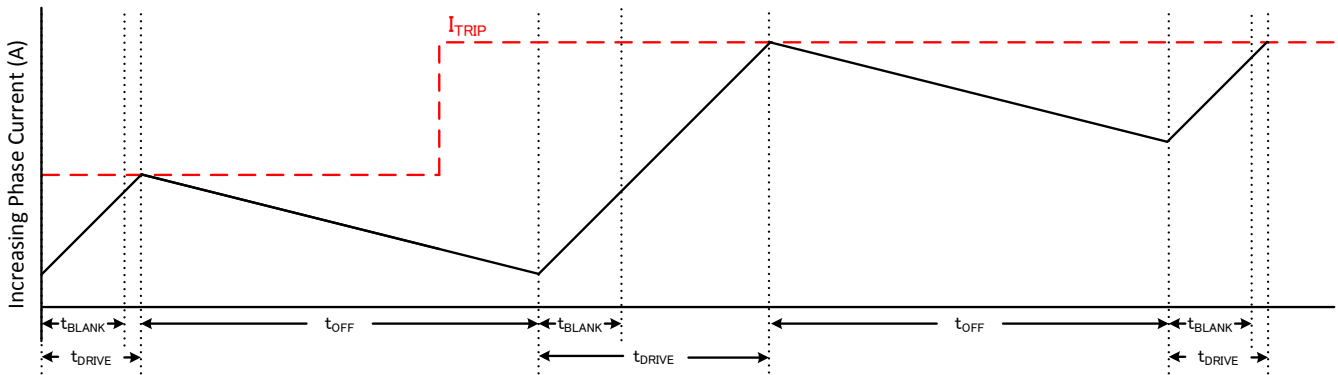

Figure 7-9. Slow-Mixed Decay Mode

Mixed decay begins as fast decay for a time, followed by slow decay for the remainder of the t_{OFF} time. In this mode, mixed decay only occurs during decreasing current. Slow decay is used for increasing current.

This mode exhibits the same current ripple as slow decay for increasing current, because for increasing current, only slow decay is used. For decreasing current, the ripple is larger than slow decay, but smaller than fast decay. On decreasing current steps, mixed decay settles to the new I_{TRIP} level faster than slow decay.

7.3.6.3 Mode 4: Slow Decay for Increasing Current, Fast Decay for Decreasing current



Please note that these graphs are not the same scale; t_{OFF} is the same

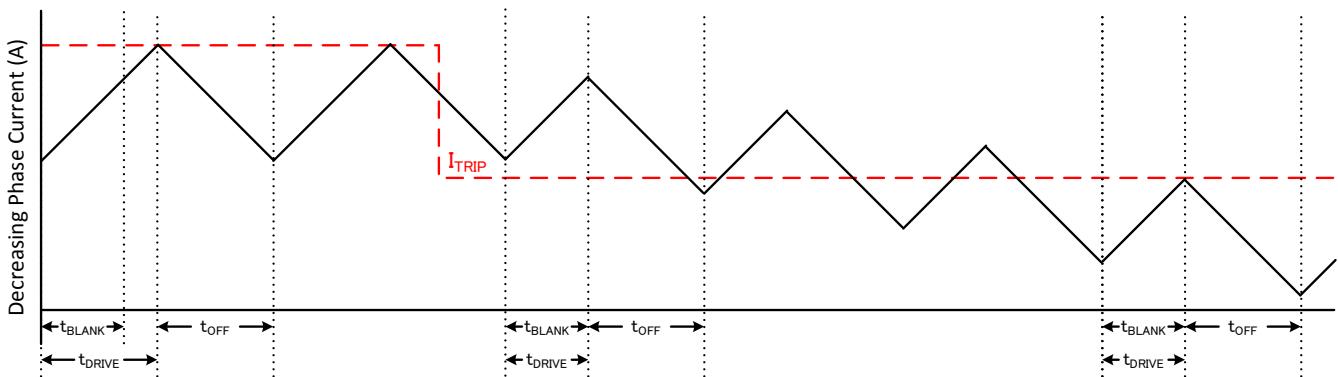

Figure 7-10. Slow/Fast Decay Mode

During fast decay, the polarity of the H-bridge is reversed. The H-bridge will be turned off as current approaches zero in order to prevent current flow in the reverse direction. In this mode, fast decay only occurs during decreasing current. Slow decay is used for increasing current.

Fast decay exhibits the highest current ripple of the decay modes for a given t_{OFF} . Transition time on decreasing current steps is much faster than slow decay since the current is allowed to decrease much faster.

7.3.6.4 Mixed Decay for Increasing and Decreasing Current

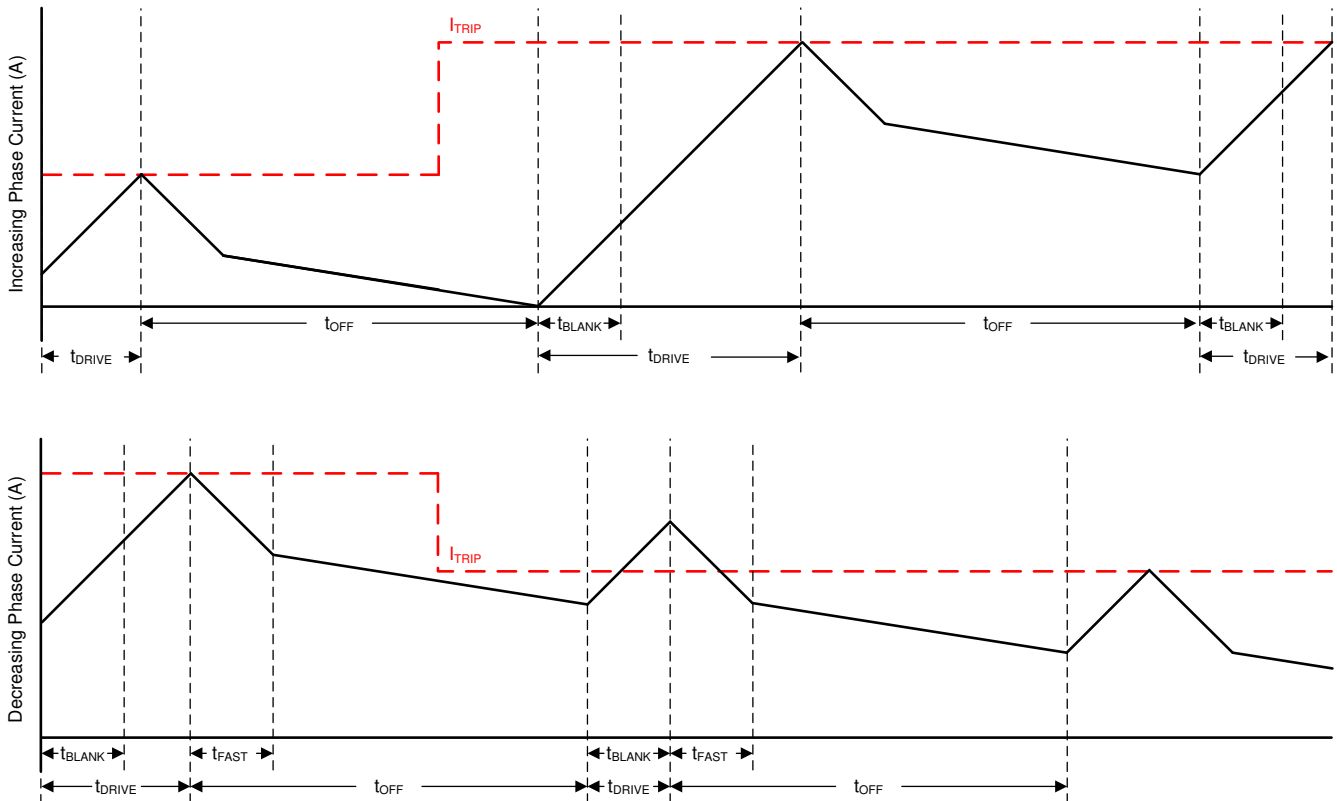

Figure 7-11. Mixed-Mixed Decay Mode

Mixed decay begins as fast decay for a time, followed by slow decay for the remainder of t_{OFF} . In this mode, mixed decay occurs for both increasing and decreasing current steps.

This mode exhibits ripple larger than slow decay, but smaller than fast decay. On decreasing current steps, mixed decay settles to the new I_{TRIP} level faster than slow decay.

In cases where current is held for a long time (no input in the STEP pin) or at very low stepping speeds, slow decay may not properly regulate current because no back-EMF is present across the motor windings. In this state, motor current can rise very quickly, and requires an excessively large off-time. Increasing or decreasing mixed decay mode allows the current level to stay in regulation when no back-EMF is present across the motor windings.

7.3.6.5 Smart tune Dynamic Decay

The smart tune current regulation schemes are advanced current-regulation control methods compared to traditional fixed off-time current regulation schemes. Smart tune current regulation schemes help the stepper motor driver adjust the decay scheme based on operating factors such as the ones listed as follows:

- Motor winding resistance and inductance
- Motor aging effects
- Motor dynamic speed and load
- Motor supply voltage variation
- Motor back-EMF difference on rising and falling steps
- Step transitions
- Low-current versus high-current di/dt

The device provides two different smart tune current regulation modes, named smart tune Dynamic Decay and smart tune Ripple Control.

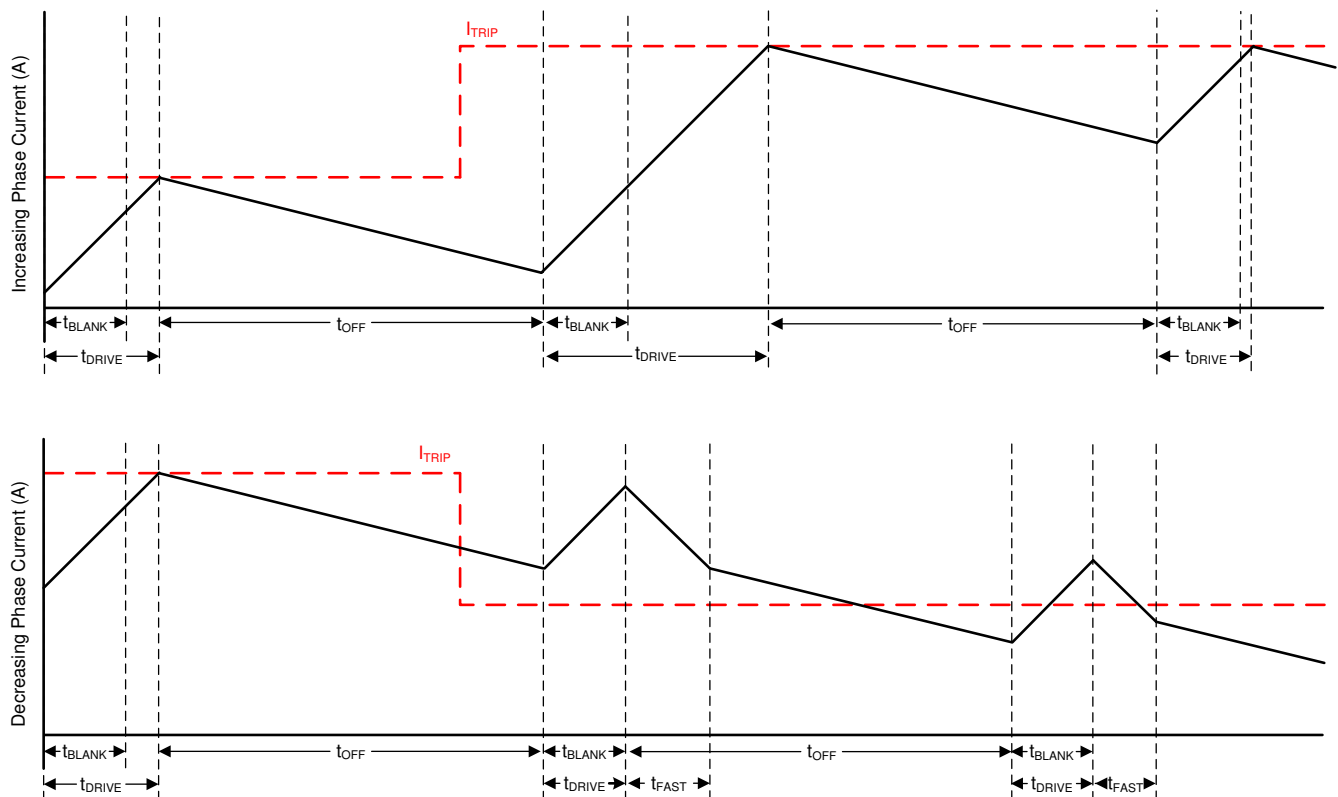

Figure 7-12. Smart tune Dynamic Decay Mode

Smart tune Dynamic Decay greatly simplifies the decay mode selection by automatically configuring the decay mode between slow, mixed, and fast decay. In mixed decay, smart tune dynamically adjusts the fast decay percentage of the total mixed decay time. This feature eliminates motor tuning by automatically determining the best decay setting that results in the lowest ripple for the motor.

The decay mode setting is optimized iteratively each PWM cycle. If the motor current overshoots the target trip level, then the decay mode becomes more aggressive (add fast decay percentage) on the next cycle to prevent regulation loss. If a long drive time must occur to reach the target trip level, the decay mode becomes less aggressive (remove fast decay percentage) on the next cycle to operate with less ripple and more efficiently. On falling steps, smart tune Dynamic Decay automatically switches to fast decay to reach the next step quickly.

Smart tune Dynamic Decay is optimal for applications that require minimal current ripple but want to maintain a fixed frequency in the current regulation scheme.

7.3.6.6 Smart tune Ripple Control

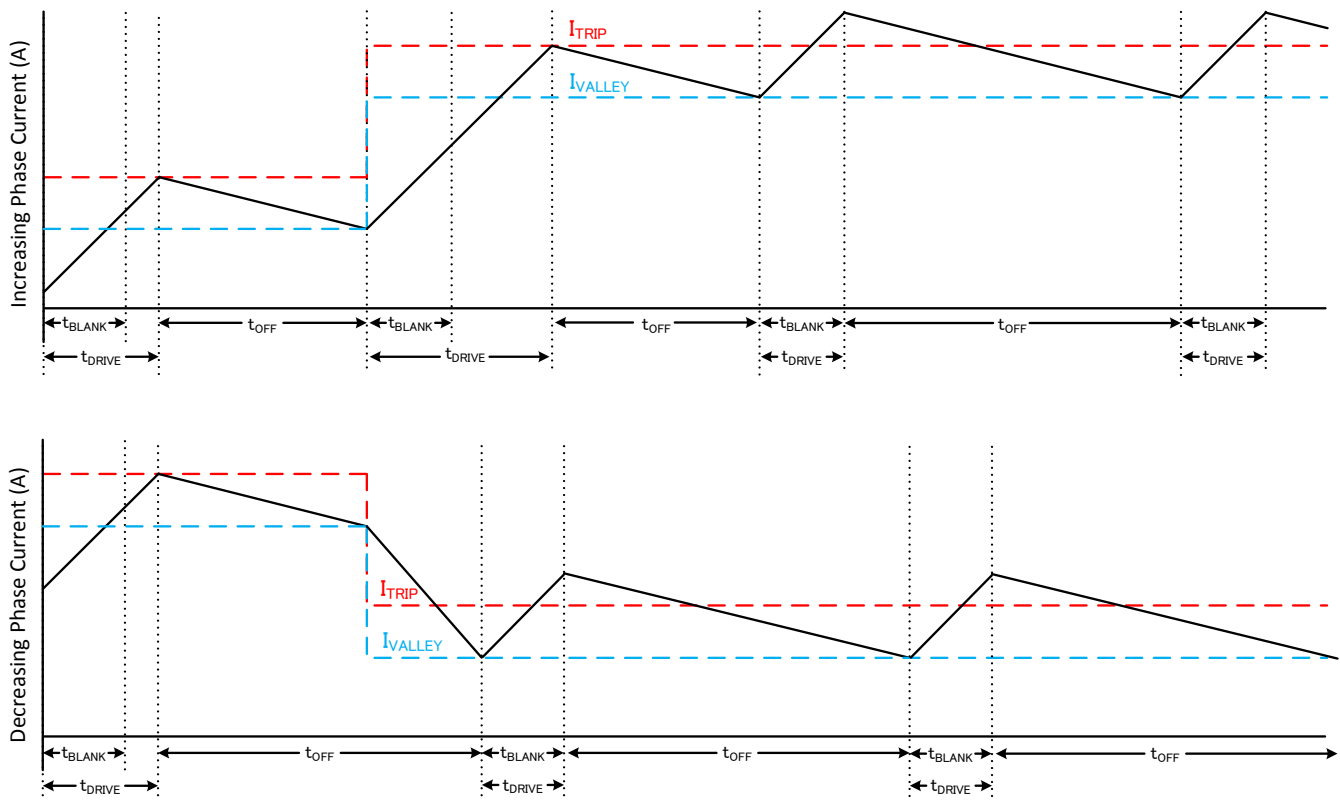

Figure 7-13. Smart tune Ripple Control Decay Mode

Smart tune Ripple Control operates by setting an I_{VALLEY} level alongside the I_{TRIP} level. When the current level reaches I_{TRIP} , instead of entering slow decay until the t_{OFF} time expires, the driver enters slow decay until I_{VALLEY} is reached. Slow decay operates similar to mode 1 in which both low-side MOSFETs are turned on allowing the current to recirculate. In this mode, t_{OFF} varies depending on the current level and operating conditions.

This method allows much tighter regulation of the current level increasing motor efficiency and system performance. Smart tune Ripple Control can be used in systems that can tolerate a variable off-time regulation scheme to achieve small current ripple in the current regulation.

7.3.7 Blanking Time

After the current is enabled (start of drive phase) in an H-bridge, the current sense comparator is ignored for a period of time (t_{BLANK}) before enabling the current-sense circuitry. The blanking time also sets the minimum drive time of the PWM. When the device goes into a drive phase at the end of a slow-decay phase, the blanking time is roughly 500 ns. If the device goes into drive phase at the end of a fast-decay phase, the approximate blanking time is as shown in the following table -

Table 7-8. Blanking Time

| SLEW_RATE | Blanking Time (t_{BLANK}) |
|-----------|-------------------------------|
| 00b | 5.6 μ s |
| 01b | 2 μ s |
| 10b | 1.5 μ s |
| 11b | 860 ns |

7.3.8 Charge Pump

A charge pump is integrated to supply a high-side N-channel MOSFET gate-drive voltage. The charge pump requires a capacitor between the VM and VCP pins to act as the storage capacitor. Additionally a ceramic capacitor is required between the CPH and CPL pins to act as the flying capacitor.

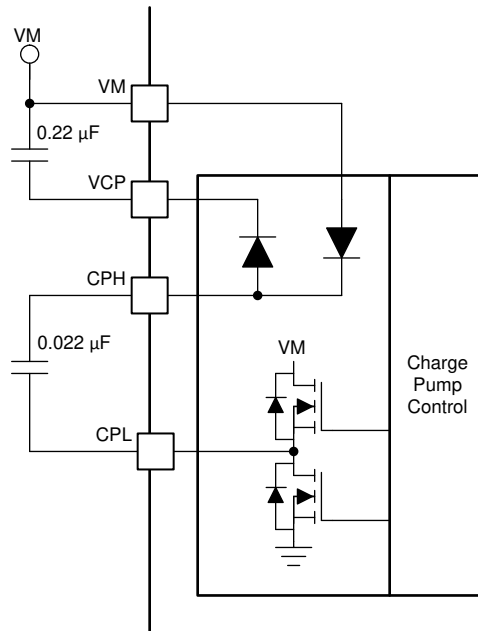

Figure 7-14. Charge Pump Block Diagram

7.3.9 Linear Voltage Regulators

A linear voltage regulator is integrated into the device. The DVDD regulator can be used to provide a reference voltage. DVDD can supply a maximum of 2 mA load. For proper operation, bypass the DVDD pin to GND using a ceramic capacitor.

The DVDD output is nominally 5-V. When the DVDD LDO current load exceeds 2 mA, the output voltage drops significantly.

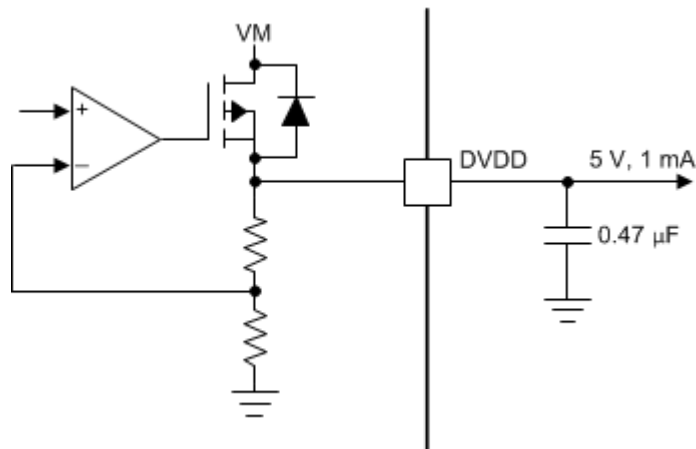

Figure 7-15. Linear Voltage Regulator Block Diagram

If logic level inputs must be tied permanently high, tying the input to the DVDD pin instead of an external regulator is preferred. This method saves power when the VM pin is not applied or in sleep mode: the DVDD regulator is disabled and current does not flow through the input pulldown resistors. For reference, logic level inputs have a typical pulldown of 200 k Ω .

The nSLEEP pin cannot be tied to DVDD, else the device will never exit sleep mode.

7.3.10 Logic Level Pin Diagrams

Figure 7-16 shows the input structure for the logic-level pins STEP, DIR, nSLEEP, SDI, and SCLK.

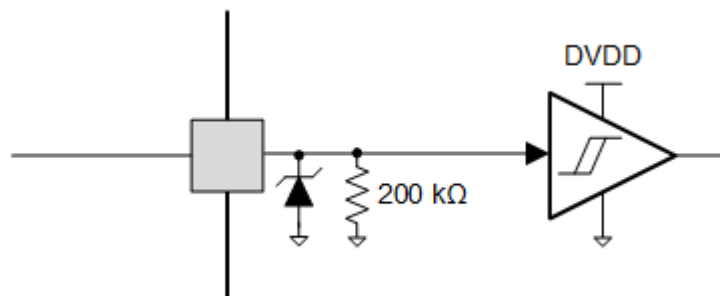

Figure 7-16. Logic-Level Input Pin Diagram

Figure 7-17 shows the input structure for the logic-level pins DRVOFF, and nSCS.

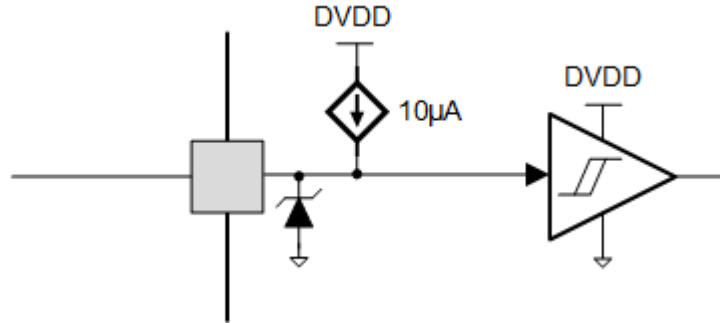

Figure 7-17. Logic-Level with Internal Pull-up Input Pin Diagram

7.3.10.1 nFAULT Pin

The nFAULT pin has an open-drain output and should be pulled up to a 5-V or 3.3-V supply. When a fault is detected, the nFAULT pin is logic low. nFAULT pin will be high after power-up. For a 5-V pullup, the nFAULT pin can be tied to the DVDD pin with a resistor. For a 3.3-V pullup, an external 3.3-V supply must be used.

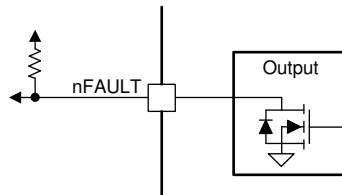

Figure 7-18. nFAULT Pin

7.3.11 Protection Circuits

The device is fully protected against supply undervoltage, charge pump undervoltage, output overcurrent, device overtemperature, and open load events.

7.3.11.1 VM Undervoltage Lockout (UVLO)

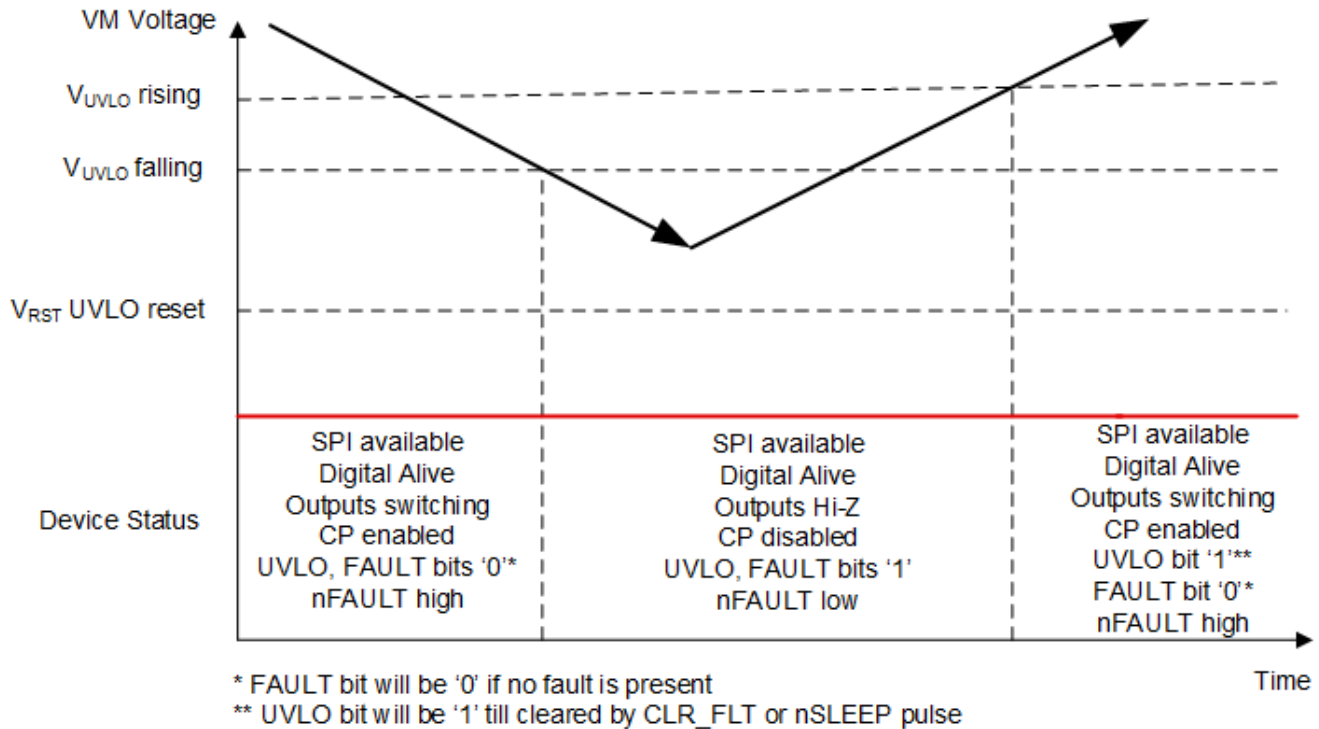

Figure 7-19. Supply Voltage Ramp Profile

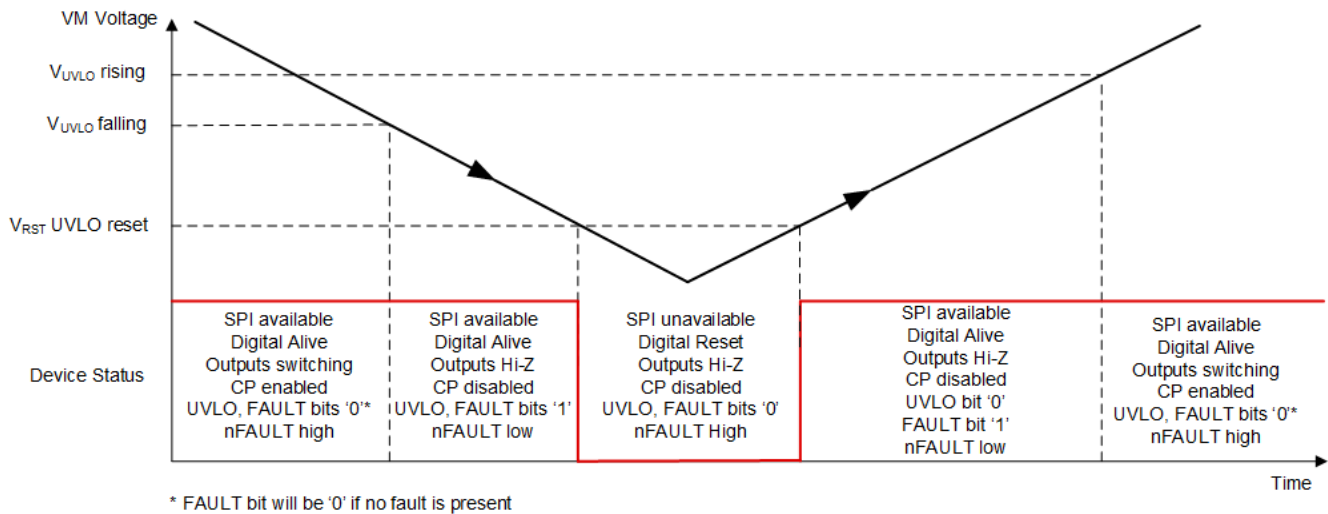

Figure 7-20. Supply Voltage Ramp Profile

If at any time the voltage on the VM pin falls below the UVLO falling threshold voltage, all the outputs are disabled (High-Z) and the charge pump (CP) is disabled. Normal operation resumes (motor driver and charge pump) when the VM voltage recovers above the UVLO rising threshold voltage.

When the voltage on the VM pin falls below the UVLO falling threshold voltage (4.25 V typical), but is above the VM UVLO reset voltage (V_{RST} , 3.9 V maximum), SPI communication is available, the digital core of the device is alive, the FAULT and UVLO bits are made high in the SPI registers and the nFAULT pin is driven low, as shown in Figure 7-19. From this condition, if the VM voltage recovers above the UVLO rising threshold voltage (4.35 V

typical), nFAULT pin is released (is pulled-up to the external voltage), and the FAULT bit is reset, but the UVLO bit remains latched high until cleared through the CLR_FLT bit or an nSLEEP reset pulse.

When the voltage on the VM pin falls below the VM UVLO reset voltage (V_{RST} , 3.9 V maximum), SPI communication is unavailable, the digital core is shutdown, the FAULT and UVLO bits are low and the nFAULT pin is high. During the subsequent power-up, when the VM voltage exceeds the V_{RST} voltage, the digital core comes alive, UVLO bit stays low but the FAULT bit is made high; and the nFAULT pin is pulled low, as shown in Figure 7-20. When the VM voltage exceeds the VM UVLO rising threshold, FAULT bit is reset, UVLO bit stays low and the nFAULT pin is pulled high.

7.3.11.2 VCP Undervoltage Lockout (CPUV)

If at any time the voltage on the VCP pin falls below the CPUV voltage, all the outputs are disabled, and the nFAULT pin is driven low. The charge pump remains active during this condition. The FAULT and CPUV bits are made high in the SPI registers. Normal operation resumes (motor-driver operation starts, nFAULT released and FAULT bit is made low) when the VCP undervoltage condition is removed. The CPUV bit remains set until it is cleared through the CLR_FLT bit or an nSLEEP reset pulse.

7.3.11.3 Overcurrent Protection (OCP)

An analog current-limit circuit on each FET limits the current through the FET by removing the gate drive. If this current limit persists for longer than the t_{OCP} time, the FETs in that particular H-bridge are disabled and the nFAULT pin is driven low. The FAULT and OCP bits are latched high in the SPI registers. For xOUTx to VM short, corresponding OCP_LSx_x bit goes high in the DIAG Status 1 register. Similarly, for xOUTx to ground short, corresponding OCP_HSx_x bit goes high. For example, for AOUT1 to VM short, OCP_LS1_A bit goes high; and for BOUT2 to ground short, the OCP_HS2_B bit goes high. The charge pump remains active during this condition. The overcurrent protection can operate in two different modes: latched shutdown and automatic retry.

7.3.11.3.1 Latched Shutdown (OCP_MODE = 0b)

In this mode, after an OCP event, the relevant outputs are disabled and the nFAULT pin is driven low. Normal operation resumes after sending a CLR_FLT command, or an nSLEEP reset pulse or a power cycling. This is the default mode for an OCP event for the device.

7.3.11.3.2 Automatic Retry (OCP_MODE = 1b)

In this mode, after an OCP event, the relevant outputs are disabled and the nFAULT pin is driven low. Normal operation resumes automatically (motor-driver operation starts, nFAULT released and FAULT bit goes low) after the t_{RETRY} time has elapsed and the fault condition is removed.

7.3.11.4 Open-Load Detection (OL)

If the winding current in any coil drops below the open load current threshold (I_{OL}) and the I_{TRIP} level set by the indexer, and if this condition persists for more than the open load detection time (t_{OL}), an open-load condition is detected. The EN_OL bit must be '1' to enable open load detection. When an open load fault is detected, the OL and FAULT bits are latched high in the SPI register and the nFAULT pin is driven low. If the OL_A bit is high, it indicates an open load fault in winding A, between AOUT1 and AOUT2. Similarly, an open load fault between BOUT1 and BOUT2 causes the OL_B bit to go high. Normal operation resumes and the nFAULT line is released when the open load condition is removed and a clear faults command has been issued either through the CLR_FLT bit or an nSLEEP reset pulse. The fault also clears when the device is power cycled or comes out of sleep mode.

If the motor is held at a position corresponding to 0°, 90°, 180° or 270° electrical angles, for more than the open load detection time, open load fault will be flagged, as one of the coil current is zero. This situation does not arise in full-step mode, because the coil currents are never zero.

7.3.11.5 Thermal Shutdown (OTSD)

If the die temperature exceeds the thermal shutdown limit (T_{OTSD}) all MOSFETs in the H-bridge are disabled, and the nFAULT pin is driven low. The charge pump is disabled in this condition. In addition, the FAULT, TF

and OTS bits are latched high. This protection feature cannot be disabled. The overtemperature protection can operate in two different modes: latched shutdown and automatic recovery.

7.3.11.5.1 Latched Shutdown (OTSD_MODE = 0b)

In this mode, after a OTSD event all the outputs are disabled and the nFAULT pin is driven low. The FAULT, TF and OTS bits are latched high in the SPI register. Normal operation resumes after sending a CLR_FLT command, or an nSLEEP reset pulse or a power cycling. This mode is the default mode for a OTSD event.

7.3.11.5.2 Automatic Recovery (OTSD_MODE = 1b)

In this mode, after a OTSD event all the outputs are disabled and the nFAULT pin is driven low. The FAULT, TF and OTS bits are latched high in the SPI register. Normal operation resumes (motor-driver operation starts, nFAULT line released and FAULT bit goes low) when the junction temperature falls below the overtemperature threshold limit minus the hysteresis ($T_{OTSD} - T_{HYS_OTSD}$). The TF and OTS bits remains latched high indicating that a thermal event occurred until a clear faults command is issued either through the CLR_FLT bit or an nSLEEP reset pulse.

7.3.11.6 Overtemperature Warning (OTW)

If the die temperature exceeds the trip point of the overtemperature warning (T_{OTW}), the OTW and TF bits are set in the SPI register. The device performs no additional action and continues to function. When the die temperature falls below the hysteresis point (T_{HYS_OTW}) of the overtemperature warning, the OTW and TF bits clear automatically. The OTW bit can also be configured to report on the nFAULT pin, and set the FAULT bit in the device, by setting the TW_REP bit to 1b through the SPI registers. The charge pump remains active during this condition.

7.3.11.7 Undertemperature Warning (UTW)

If the die temperature falls below the trip point of the undertemperature warning (T_{UTW}), the UTW and TF bits are set in the SPI register. The device performs no additional action and continues to function. When the die temperature exceeds the hysteresis point (T_{HYS_UTW}) of the undertemperature warning, the UTW and TF bits clear automatically. The UTW bit can also be configured to report on the nFAULT pin, and set the FAULT bit in the device, by setting the TW_REP bit to 1b through the SPI registers. The charge pump remains active during this condition.

Table 7-9. Fault Condition Summary

| FAULT | CONDITION | CONFIGURATION | ERROR REPORT | H-BRIDGE | CHARGE PUMP | INDEXER | LOGIC | RECOVERY |
|--------------------------------|---------------------------------------|-------------------|--------------|-----------|-------------|-----------|---------------------------|--|
| VM undervoltage (UVLO) | $VM < V_{UVLO}$ (max 4.35 V) | — | nFAULT / SPI | Disabled | Disabled | Disabled | Reset ($V_{VM} < 3.9$ V) | Automatic: $VM > V_{UVLO}$ (max 4.45 V) |
| VCP undervoltage (CPUV) | $VCP < V_{CPUV}$ (typ VM + 2.25 V) | — | nFAULT / SPI | Disabled | Operating | Operating | Operating | $VCP > V_{CPUV}$ (typ VM + 2.7 V) |
| Overcurrent (OCP) | $I_{OUT} > I_{OCP}$ (min 1.7 A) | OCP_MOD E = 0b | nFAULT / SPI | Disabled | Operating | Operating | Operating | Latched: CLR_FLT / nSLEEP |
| | | OCP_MOD E = 1b | nFAULT / SPI | Disabled | Operating | Operating | Operating | Automatic retry: t_{RETRY} |
| Open Load (OL) | No load detected | EN_OL = 1b | nFAULT / SPI | Operating | Operating | Operating | Operating | Report only |
| Overtemperature Warning (OTW) | $T_J > T_{OTW}$ | TW_REP = 1b | nFAULT / SPI | Operating | Operating | Operating | Operating | Automatic: $T_J < T_{OTW} - T_{HYS_OTW}$ |
| | | TW_REP = 0b | SPI | Operating | Operating | Operating | Operating | |
| Undertemperature Warning (UTW) | $T_J < T_{UTW}$ | TW_REP = 1b | nFAULT / SPI | Operating | Operating | Operating | Operating | Automatic: $T_J > T_{UTW} + T_{HYS_UTW}$ |
| | | TW_REP = 0b | SPI | Operating | Operating | Operating | Operating | |

Table 7-9. Fault Condition Summary (continued)

| FAULT | CONDITION | CONFIGURATION | ERROR REPORT | H-BRIDGE | CHARGE PUMP | INDEXER | LOGIC | RECOVERY |
|-------------------------|------------------|--------------------|-----------------|----------|-------------|-----------|-----------|---|
| Thermal Shutdown (OTSD) | $T_J > T_{OTSD}$ | OTSD_MO DE = 0b | nFAULT / SPI | Disabled | Disabled | Operating | Operating | Latched: CLR_FLT / nSLEEP |
| | | OTSD_MO DE = 1b | SPI | Disabled | Disabled | Operating | Operating | Automatic: $T_J < T_{OTSD} - T_{HYS_OTSD}$ |

7.4 Device Functional Modes

7.4.1 Sleep Mode (nSLEEP = 0)

The device state is managed by the nSLEEP pin. When the nSLEEP pin is low, the device enters a low-power sleep mode. In sleep mode, all the internal MOSFETs are disabled, the DVDD regulator is disabled, the charge pump is disabled, and the SPI is disabled. The t_{SLEEP} time must elapse after a falling edge on the nSLEEP pin before the device enters sleep mode. The device is brought out of sleep automatically if the nSLEEP pin is brought high. The t_{WAKE} time must elapse before the device is ready for inputs.

7.4.2 Disable Mode (nSLEEP = 1, DRVOFF = 1)

The DRVOFF pin is used to enable or disable the half bridges in the device. When the DRVOFF pin is high, the output drivers are disabled in the Hi-Z state.

The DIS_OUT bit can also be used to disable the output drivers. When the DIS_OUT bit is '1', the output drivers are disabled in the Hi-Z state. DIS_OUT is OR'ed with DRVOFF pin.

Table 7-10. Conditions to Enable or Disable Output Drivers

| nSLEEP | DRVOFF | DIS_OUT | H-BRIDGE |
|--------|------------|------------|-----------|
| 0 | Don't Care | Don't Care | Disabled |
| 1 | 0 | 0 | Operating |
| 1 | 0 | 1 | Disabled |
| 1 | 1 | 0 | Disabled |
| 1 | 1 | 1 | Disabled |

7.4.3 Operating Mode (nSLEEP = 1, DRVOFF = 0)

When the nSLEEP pin is high, the DRVOFF pin is low, and $VM > UVLO$, the device enters the active mode. The t_{WAKE} time must elapse before the device is ready for inputs.

7.4.4 nSLEEP Reset Pulse

In addition to the CLR_FLT bit in the SPI register, a latched fault can be cleared through a quick nSLEEP pulse. This pulse width must be greater than 18 μs and shorter than 35 μs . If nSLEEP is low for longer than 35 μs but less than 75 μs , the faults are cleared and the device may or may not shutdown, as shown in the timing diagram (see Figure 7-21). This reset pulse resets any SPI faults and does not affect the status of the charge pump or other functional blocks.

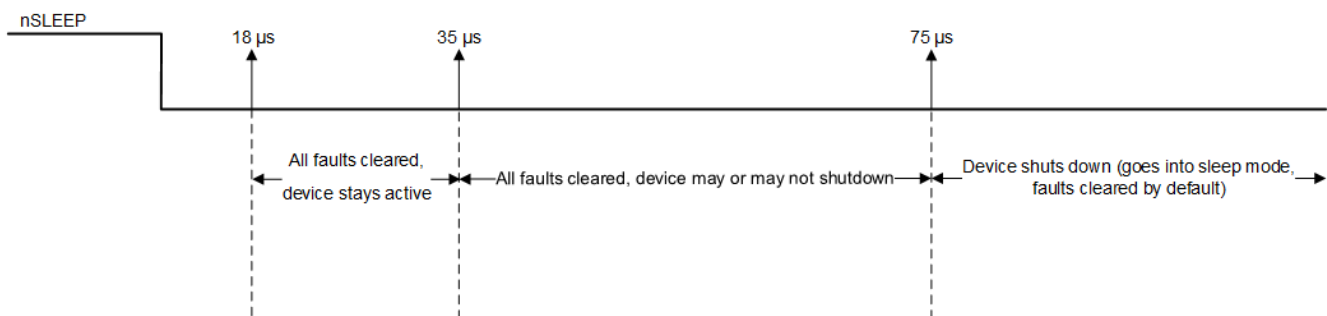

Figure 7-21. nSLEEP Reset Pulse

Table 7-11 lists a summary of the functional modes.

Table 7-11. Functional Modes Summary

| CONDITION | | CONFIGURATION | H-BRIDGE | DVDD Regulator | CHARGE PUMP | INDEXER | LOGIC |
|------------|-------------------|----------------------------------|-----------|----------------|-------------|-----------|-----------|
| Sleep mode | 4.5 V < VM < 45 V | nSLEEP pin = 0 | Disabled | Disbaled | Disabled | Disabled | Disabled |
| Operating | 4.5 V < VM < 45 V | nSLEEP pin = 1 DRVOFF pin = 0 | Operating | Operating | Operating | Operating | Operating |
| Disabled | 4.5 V < VM < 45 V | nSLEEP pin = 1 DRVOFF pin = 1 | Disabled | Operating | Operating | Operating | Operating |

7.5 Programming

7.5.1 Serial Peripheral Interface (SPI) Communication

The device SPI has full duplex, 4-wire synchronous communication. This section describes the SPI protocol, the command structure, and the control and status registers. The device can be connected with the MCU in the following configurations:

- One slave device
- Multiple slave devices in parallel connection
- Multiple slave devices in series (daisy chain) connection

7.5.1.1 SPI Format

The SDI input data word is 16 bits long and consists of the following format:

- 1 read or write bit, W (bit 14)
- 5 address bits, A (bits 13 through 9)
- 8 data bits, D (bits 7 through 0)

The SDO output-data word is 16 bits long and the first 8 bits make up the Status Register (S1). The Report word (R1) is the content of the register being accessed.

For a write command (W0 = 0), the response word on the SDO pin is the data currently in the register being written to.

For a read command (W0 = 1), the response word is the data currently in the register being read.

Table 7-12. SDI Input Data Word Format

| R/W | | ADDRESS | | | | | | DON'T CARE | DATA | | | | | | | |
|-----|-----|---------|-----|-----|-----|----|----|------------|------|----|----|----|----|----|----|--|
| B15 | B14 | B13 | B12 | B11 | B10 | B9 | B8 | B7 | B6 | B5 | B4 | B3 | B2 | B1 | B0 | |
| 0 | W0 | A4 | A3 | A2 | A1 | A0 | X | D7 | D6 | D5 | D4 | D3 | D2 | D1 | D0 | |

Table 7-13. SDO Output Data Word Format

| STATUS | | | | | | | | REPORT | | | | | | | |
|--------|-----|------|------|-----|------|----|----|--------|----|----|----|----|----|----|----|
| B15 | B14 | B13 | B12 | B11 | B10 | B9 | B8 | B7 | B6 | B5 | B4 | B3 | B2 | B1 | B0 |
| 1 | 1 | UVLO | CPUV | OCV | RSVD | TF | OL | D7 | D6 | D5 | D4 | D3 | D2 | D1 | D0 |

7.5.1.2 SPI for a Single Slave Device

The SPI is used to set device configurations, operating parameters, and read out diagnostic information. The SPI operates in slave mode. The SPI input-data (SDI) word consists of a 16-bit word, with 8 bits command and 8 bits of data. The SPI output data (SDO) word consists of 8 bits of status register with fault status indication and 8 bits of register data. Figure 7-22 shows the data sequence between the MCU and the SPI slave driver.

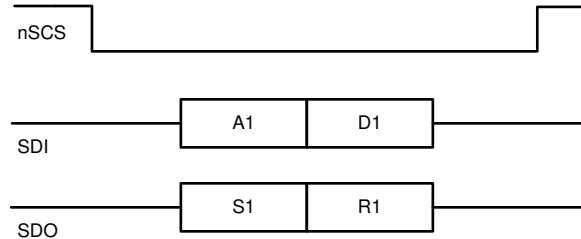

Figure 7-22. SPI Transaction Between MCU and the device

A valid frame must meet the following conditions:

- The SCLK pin must be low when the nSCS pin goes low and when the nSCS pin goes high.
- The nSCS pin should be taken high for at least 500 ns between frames.
- When the nSCS pin is asserted high, any signals at the SCLK and SDI pins are ignored, and the SDO pin is in the high-impedance state (Hi-Z).
- Full 16 SCLK cycles must occur.
- Data is captured on the falling edge of the clock and data is driven on the rising edge of the clock.
- The most-significant bit (MSB) is shifted in and out first.
- If the data word sent to SDI pin is less than 16 bits or more than 16 bits, a frame error occurs and the data word is ignored.
- For a write command, the existing data in the register being written to is shifted out on the SDO pin following the 8-bit command data.

7.5.1.3 SPI for Multiple Slave Devices in Parallel Configuration

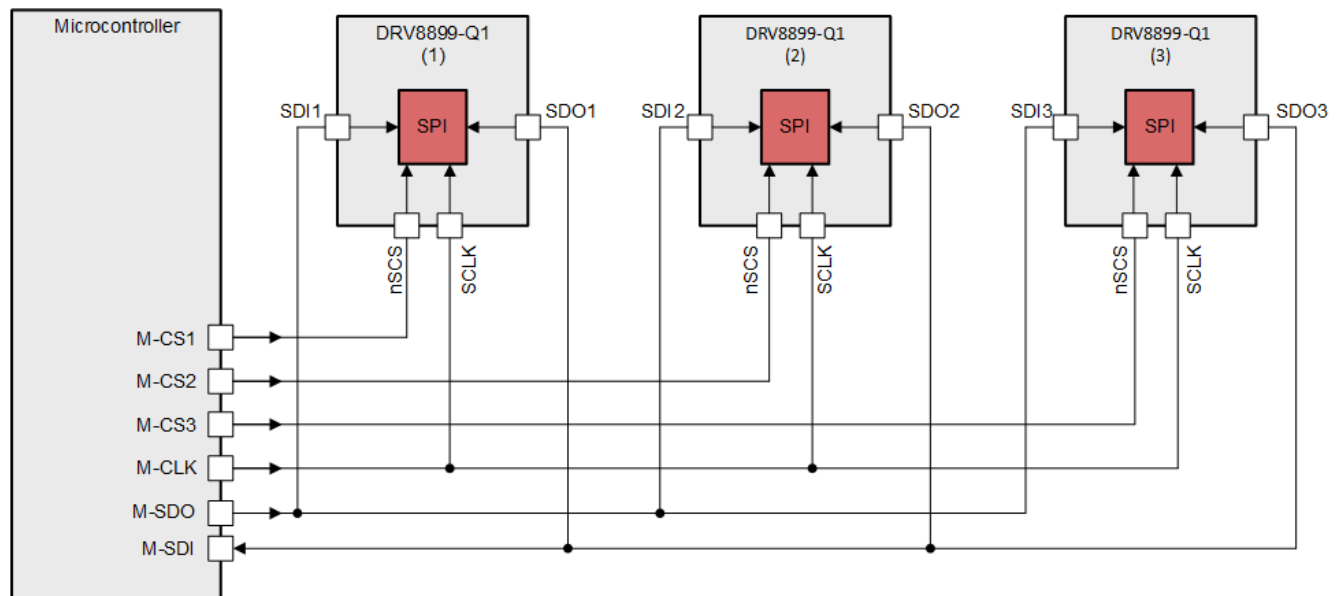

Figure 7-23. Three DRV8899-Q1 Devices Connected in Parallel Configuration

7.5.1.4 SPI for Multiple Slave Devices in Daisy Chain Configuration

The DRV8899-Q1 device can be connected in a daisy chain configuration to keep GPIO ports available when multiple devices are communicating to the same MCU. [Figure 7-24](#) shows the topology when three devices are connected in series.

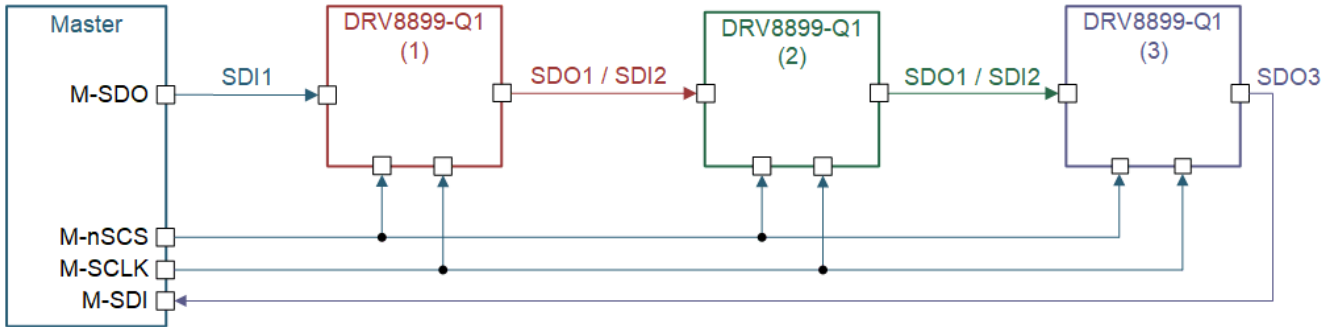

Figure 7-24. Three DRV8899-Q1 Devices Connected in Daisy Chain

The first device in the chain receives data from the MCU in the following format for 3-device configuration: 2 bytes of header (HDRx) followed by 3 bytes of address (Ax) followed by 3 bytes of data (Dx).

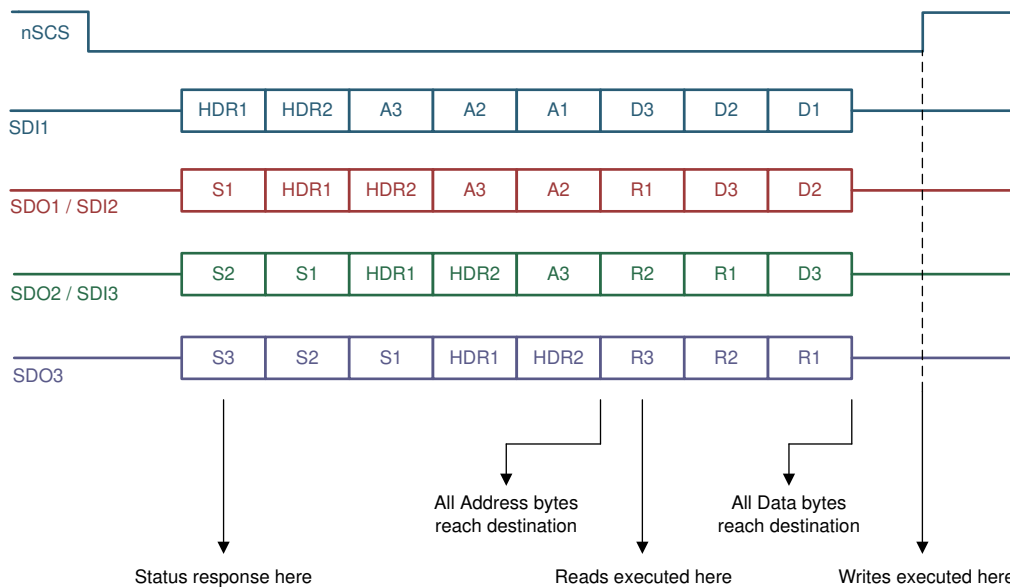

Figure 7-25. SPI Frame With Three Devices

After the data has been transmitted through the chain, the MCU receives the data string in the following format for 3-device configuration: 3 bytes of status (Sx) followed by 2 bytes of header followed by 3 bytes of report (Rx).

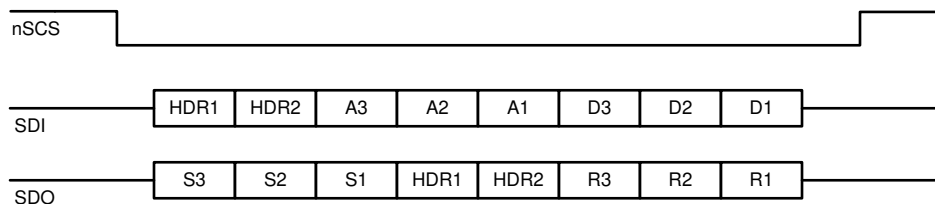

Figure 7-26. SPI Data Sequence for Three Devices

The header bytes contain information of the number of devices connected in the chain, and a global clear fault command that will clear the fault registers of all the devices on the rising edge of the chip select (nSCS) signal. Header values N5 through N0 are 6 bits dedicated to show the number of devices in the chain. Up to 63 devices can be connected in series for each daisy chain connection.

The 5 LSBs of the HDR2 register are don't care bits that can be used by the MCU to determine integrity of the daisy chain connection. Header bytes must start with 1 and 0 for the two MSBs.

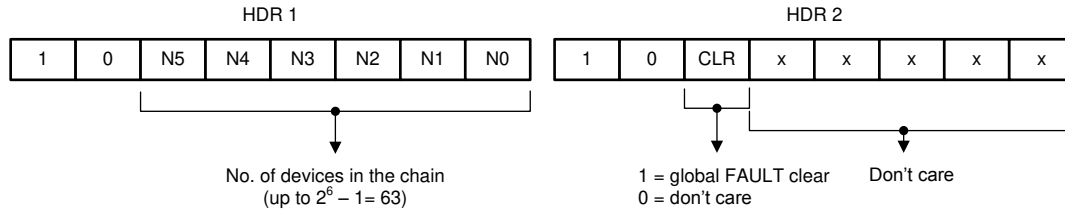

Figure 7-27. Header Bytes

The status byte provides information about the fault status register for each device in the daisy chain so that the MCU does not have to initiate a read command to read the fault status from any particular device. This keeps additional read commands for the MCU and makes the system more efficient to determine fault conditions flagged in a device. Status bytes must start with 1 and 1 for the two MSBs.

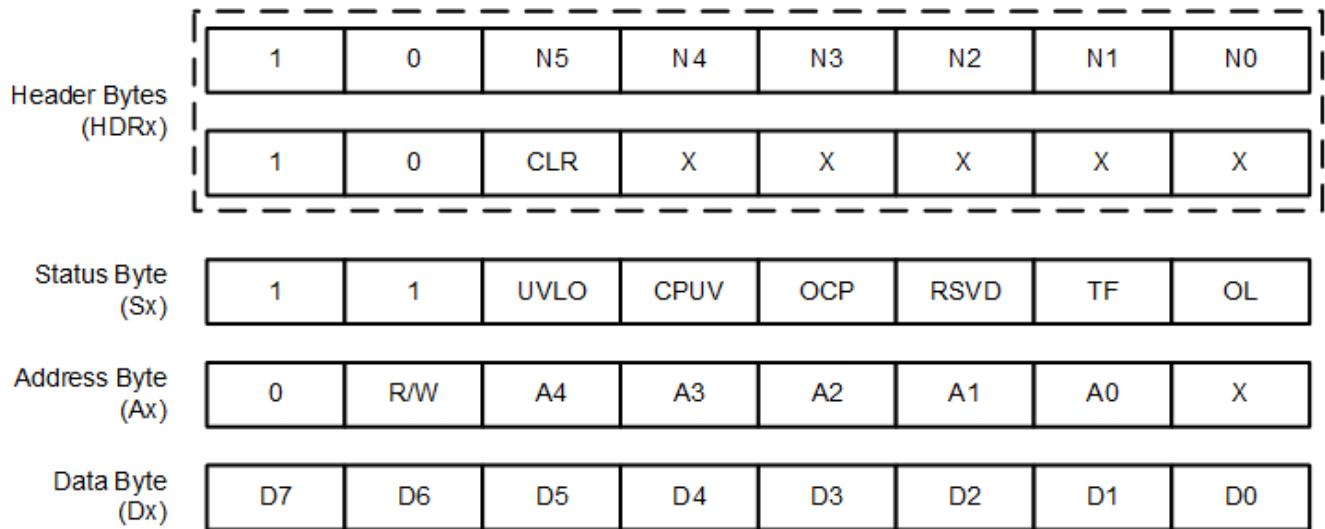

Figure 7-28. Contents of Header, Status, Address, and Data Bytes for DRV8899-Q1

When data passes through a device, it determines the position of itself in the chain by counting the number of status bytes it receives followed by the first header byte. For example, in this 3-device configuration, device 2 in the chain receives two status bytes before receiving the HDR1 byte which is then followed by the HDR2 byte.

From the two status bytes, the data can determine that its position is second in the chain. From the HDR2 byte, the data can determine how many devices are connected in the chain. In this way, the data only loads the relevant address and data byte in its buffer and bypasses the other bits. This protocol allows for faster communication without adding latency to the system for up to 63 devices in the chain.

The address and data bytes remain the same with respect to a 1-device connection. The report bytes (R1 through R3), as shown in [Figure 7-26](#), are the content of the register being accessed.

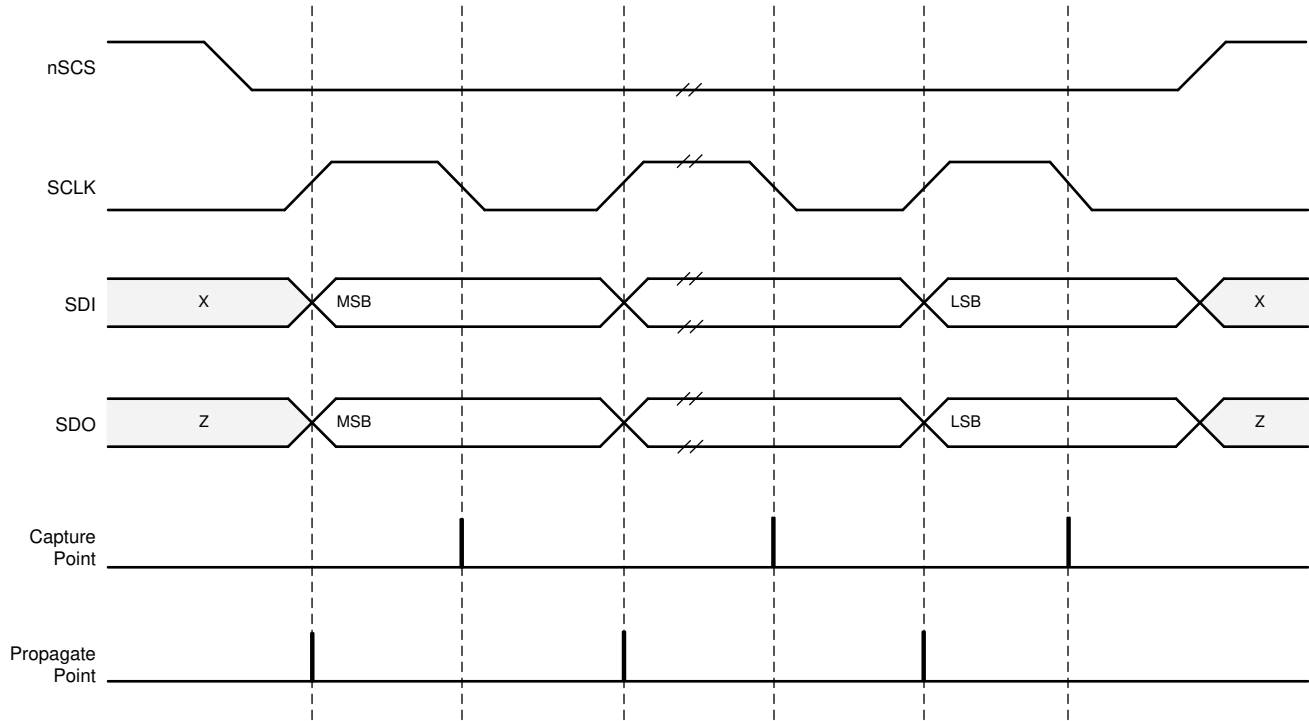

Figure 7-29. SPI Transaction

7.6 Register Maps

[Memory Map](#) lists the memory-mapped registers for the DRV8899-Q1 device. All register addresses not listed in [Memory Map](#) should be considered as reserved locations and the register contents should not be modified.

Table 7-14. Memory Map

| Register Name | 7 | 6 | 5 | 4 | 3 | 2 | 1 | 0 | Access Type | Address |
|---------------|---------------|------------|-----------|------------|----------------------|-----------------|-----------|-----------|-------------|---------|
| FAULT Status | FAULT | SPI_ERROR | UVLO | CPUV | OCF | RSVD | TF | OL | R | 0x00 |
| DIAG Status 1 | OCF_LS2_B | OCF_HS2_B | OCF_LS1_B | OCF_HS1_B | OCF_LS2_A | OCF_HS2_A | OCF_LS1_A | OCF_HS1_A | R | 0x01 |
| DIAG Status 2 | UTW | OTW | OTS | RSVD | | | OL_B | OL_A | R | 0x02 |
| CTRL1 | TRQ_DAC [3:0] | | | RSVD | | SLEW_RATE [1:0] | | | RW | 0x03 |
| CTRL2 | DIS_OUT | RSVD | | TOFF [1:0] | | DECAY [2:0] | | | RW | 0x04 |
| CTRL3 | DIR | STEP | SPI_DIR | SPI_STEP | MICROSTEP_MODE [3:0] | | | | RW | 0x05 |
| CTRL4 | CLR_FLT | LOCK [2:0] | | | EN_OL | OCF_MODE | OTSD_MODE | TW_REP | RW | 0x06 |
| CTRL5 | RSVD | | | | | | | | RW | 0x07 |
| CTRL6 | RSVD | | | | | | | | RW | 0x08 |
| CTRL7 | RSVD | | | | | | | | R | 0x09 |
| CTRL8 | RSVD | | | | REV_ID [3:0] | | | | R | 0x0A |

The differences between the register maps of the DRV8889-Q1 and DRV8889A-Q1 are - DRV8889A-Q1 has OL_TIME [1:0] and EN_SR_BLANK bits in CTRL5 register to program open-load detection time and slow-decay to drive mode blanking time. Also, the default value of the DIS_OUT bit in CTRL2 register is different in DRV8889A-Q1.

Complex bit access types are encoded to fit into small table cells. [Table 7-15](#) shows the codes that are used for access types in this section.

Table 7-15. Access Type Codes

| Access Type | Code | Description |
|------------------------|------|--|
| Read Type | | |
| R | R | Read |
| Write Type | | |
| W | W | Write |
| Reset or Default Value | | |
| -n | | Value after reset or the default value |

7.6.1 Status Registers

The status registers are used to reporting warning and fault conditions. Status registers are read-only registers

Table 7-16 lists the memory-mapped registers for the status registers. All register offset addresses not listed in Table 7-16 should be considered as reserved locations and the register contents should not be modified.

Table 7-16. Status Registers Summary Table

| Address | Register Name | Section |
|---------|---------------|--------------------|
| 0x00 | FAULT status | Go |
| 0x01 | DIAG status 1 | Go |
| 0x02 | DIAG status 2 | Go |

7.6.2 FAULT Status Register Name (address = 0x00)

FAULT status is shown in Figure 7-30 and described in Figure 7-30.

Read-only

Figure 7-30. FAULT Status Register

| 7 | 6 | 5 | 4 | 3 | 2 | 1 | 0 |
|-------|-----------|------|------|------|------|------|------|
| FAULT | SPI_ERROR | UVLO | CPUV | OCP | RSVD | TF | OL |
| R-0b | R-0b | R-0b | R-0b | R-0b | R-0b | R-0b | R-0b |

Table 7-17. FAULT Status Register Field Descriptions

| Bit | Field | Type | Default | Description |
|-----|-----------|------|---------|--|
| 7 | FAULT | R | 0b | When nFAULT pin is at 1, FAULT bit is 0. When nFAULT pin is at 0, FAULT bit is 1. |
| 6 | SPI_ERROR | R | 0b | Indicates SPI protocol errors, such as more SCLK pulses than are required or SCLK is absent even though nSCS is low. Becomes high in fault and the nFAULT pin is driven low. Normal operation resumes when the protocol error is removed and a clear faults command has been issued either through the CLR_FLT bit or an nSLEEP reset pulse. |
| 5 | UVLO | R | 0b | Indicates an undervoltage lockout fault condition. |
| 4 | CPUV | R | 0b | Indicates charge pump undervoltage fault condition. |
| 3 | OCP | R | 0b | Indicates overcurrent fault condition |
| 2 | RSVD | R | 0b | Reserved. |
| 1 | TF | R | 0b | Logic OR of the overtemperature warning, undertemperature warning and overtemperature shutdown. |
| 0 | OL | R | 0b | Indicates open-load condition. |

7.6.3 DIAG Status 1 (address = 0x01)

DIAG Status 1 is shown in Figure 7-31 and described in Table 7-18.

Read-only

Figure 7-31. DIAG Status 1 Register

| 7 | 6 | 5 | 4 | 3 | 2 | 1 | 0 |
|-----------|-----------|-----------|-----------|-----------|-----------|-----------|-----------|
| OCP_LS2_B | OCP_HS2_B | OCP_LS1_B | OCP_HS1_B | OCP_LS2_A | OCP_HS2_A | OCP_LS1_A | OCP_HS1_A |
| R-0b | R-0b | R-0b | R-0b | R-0b | R-0b | R-0b | R-0b |

Table 7-18. DIAG Status 1 Register Field Descriptions

| Bit | Field | Type | Default | Description |
|-----|-----------|------|---------|---|
| 7 | OCP_LS2_B | R | 0b | Indicates overcurrent fault on the low-side FET of half bridge 2 in BOUT |
| 6 | OCP_HS2_B | R | 0b | Indicates overcurrent fault on the high-side FET of half bridge 2 in BOUT |
| 5 | OCP_LS1_B | R | 0b | Indicates overcurrent fault on the low-side FET of half bridge 1 in BOUT |
| 4 | OCP_HS1_B | R | 0b | Indicates overcurrent fault on the high-side FET of half bridge 1 in BOUT |
| 3 | OCP_LS2_A | R | 0b | Indicates overcurrent fault on the low-side FET of half bridge 2 in AOUT |
| 2 | OCP_HS2_A | R | 0b | Indicates overcurrent fault on the high-side FET of half bridge 2 in AOUT |
| 1 | OCP_LS1_A | R | 0b | Indicates overcurrent fault on the low-side FET of half bridge 1 in AOUT |
| 0 | OCP_HS1_A | R | 0b | Indicates overcurrent fault on the high-side FET of half bridge 1 in AOUT |

7.6.4 DIAG Status 2 (address = 0x02)

DIAG Status 2 is shown in [Figure 7-32](#) and described in [Table 7-19](#).

Read-only

Figure 7-32. DIAG Status 2 Register

| 7 | 6 | 5 | 4 | 3 | 2 | 1 | 0 |
|------|------|------|--------|---|---|------|------|
| UTW | OTW | OTS | RSVD | | | OL_B | OL_A |
| R-0b | R-0b | R-0b | R-000b | | | R-0b | R-0b |

Table 7-19. DIAG Status 2 Register Field Descriptions

| Bit | Field | Type | Default | Description |
|-----|-------|------|---------|---------------------------------------|
| 7 | UTW | R | 0b | Indicates undertemperature warning. |
| 6 | OTW | R | 0b | Indicates overtemperature warning. |
| 5 | OTS | R | 0b | Indicates overtemperature shutdown. |
| 4-2 | RSVD | R | 000b | Reserved. |
| 1 | OL_B | R | 0b | Indicates open-load detection on BOUT |
| 0 | OL_A | R | 0b | Indicates open-load detection on AOUT |

7.6.5 Control Registers

The IC control registers are used to configure the device. Status registers are read and write capable.

[Table 7-20](#) lists the memory-mapped registers for the control registers. All register offset addresses not listed in [Table 7-20](#) should be considered as reserved locations and the register contents should not be modified.

Table 7-20. Control Registers Summary Table

| Address | Register Name | Section |
|---------|---------------|--------------------|
| 0x03 | CTRL1 | Go |
| 0x04 | CTRL2 | Go |

Table 7-20. Control Registers Summary Table (continued)

| Address | Register Name | Section |
|---------|---------------|--------------------|
| 0x05 | CTRL3 | Go |
| 0x06 | CTRL4 | Go |
| 0x07 | CTRL5 | Go |
| 0x08 | CTRL6 | Go |
| 0x09 | CTRL7 | Go |

7.6.6 CTRL1 Control Register (address = 0x03)

CTRL1 control is shown in [Figure 7-33](#) and described in [Table 7-21](#).

Read/Write

Figure 7-33. CTRL1 Control Register

| 7 | 6 | 5 | 4 | 3 | 2 | 1 | 0 |
|---------------|---|---|---|---------|---|-----------------|---|
| TRQ_DAC [3:0] | | | | RSVD | | SLEW_RATE [1:0] | |
| R/W-0000b | | | | R/W-00b | | R/W-00b | |

Table 7-21. CTRL1 Control Register Field Descriptions

| Bit | Field | Type | Default | Description |
|-----|-----------------|------|---------|---|
| 7-4 | TRQ_DAC [3:0] | R/W | 0000b | 0000b = 100% 0001b = 93.75% 0010b = 87.5% 0011b = 81.25% 0100b = 75% 0101b = 68.75% 0110b = 62.5% 0111b = 56.25% 1000b = 50% 1001b = 43.75% 1010b = 37.5% 1011b = 31.25% 1100b = 25% 1101b = 18.75% 1110b = 12.5% 1111b = 6.25% |
| 3-2 | RSVD | R/W | 00b | Reserved |
| 1-0 | SLEW_RATE [1:0] | R/W | 00b | 00b = 10-V/μs 01b = 35-V/μs 10b = 50-V/μs 11b = 105-V/μs |

7.6.7 CTRL2 Control Register (address = 0x04)

CTRL2 is shown in [Figure 7-34](#) and CTRL2 Control Register for DRV8889A-Q1 and described in [Table 7-22](#).

Read/Write

Figure 7-34. CTRL2 Control Register for DRV8889-Q1

| 7 | 6 | 5 | 4 | 3 | 2 | 1 | 0 |
|---------|------|---|------------|---|-------------|---|---|
| DIS_OUT | RSVD | | TOFF [1:0] | | DECAY [2:0] | | |

Figure 7-34. CTRL2 Control Register for DRV8889-Q1 (continued)

| | | | |
|--------|---------|---------|----------|
| R/W-0b | R/W-00b | R/W-01b | R/W-111b |
|--------|---------|---------|----------|

Table 7-22. CTRL2 Control Register Field Descriptions for DRV8889-Q1

| Bit | Field | Type | Default | Description |
|-----|-------------|------|-------------------------------------|--|
| 7 | DIS_OUT | R/W | 0b (DRV8889-Q1) 1b (DRV8889A-Q1) | Write '1' to Hi-Z all outputs. Write '0' to enable all outputs. OR'ed with DRVOFF pin. To prevent false OL detection, ensure OL fault detection is disabled by writing '0' to EN_OL bit, before making the outputs Hi-Z by writing '1' to DIS_OUT. |
| 6-5 | RSVD | R/W | 00b | Reserved |
| 4-3 | TOFF [1:0] | R/W | 01b | 00b = 7 μ s 01b = 16 μs 10b = 24 μ s 11b = 32 μ s |
| 2-0 | DECAY [2:0] | R/W | 111b | 000b = Increasing SLOW, decreasing SLOW 001b = Increasing SLOW, decreasing MIXED 30% 010b = Increasing SLOW, decreasing MIXED 60% 011b = Increasing SLOW, decreasing FAST 100b = Increasing MIXED 30%, decreasing MIXED 30% 101b = Increasing MIXED 60%, decreasing MIXED 60% 110b = Smart tune Dynamic Decay 111b = Smart tune Ripple Control |

7.6.8 CTRL3 Control Register (address = 0x05)

CTRL3 is shown in [Figure 7-35](#) and described in [Table 7-23](#).

Read/Write

Figure 7-35. CTRL3 Control Register

| | | | | | | | |
|--------|--------|---------|----------|----------------------|---|---|---|
| 7 | 6 | 5 | 4 | 3 | 2 | 1 | 0 |
| DIR | STEP | SPI_DIR | SPI_STEP | MICROSTEP_MODE [3:0] | | | |
| R/W-0b | R/W-0b | R/W-0b | R/W-0b | R/W-0000b | | | |

Table 7-23. CTRL3 Control Register Field Descriptions

| Bit | Field | Type | Default | Description |
|-----|----------|------|---------|--|
| 7 | DIR | R/W | 0b | Direction input. Logic '1' sets the direction of stepping, when SPI_DIR = 1. |
| 6 | STEP | R/W | 0b | Step input. Logic '1' causes the indexer to advance one step, when SPI_STEP = 1. This bit is self-clearing, automatically becomes '0' after writing '1'. |
| 5 | SPI_DIR | R/W | 0b | 0b = Outputs follow input pin for DIR 1b = Outputs follow SPI registers DIR |
| 4 | SPI_STEP | R/W | 0b | 0b = Outputs follow input pin for STEP 1b = Outputs follow SPI registers STEP |

Table 7-23. CTRL3 Control Register Field Descriptions (continued)

| Bit | Field | Type | Default | Description |
|-----|----------------------|------|---------|---|
| 3-0 | MICROSTEP_MODE [3:0] | R/W | 0000b | 0000b = Full step (2-phase excitation) with 100% current 0001b = Full step (2-phase excitation) with 71% current 0010b = Non-circular 1/2 step 0011b = 1/2 step 0100b = 1/4 step 0101b = 1/8 step 0110b = 1/16 step 0111b = 1/32 step 1000b = 1/64 step 1001b = 1/128 step 1010b = 1/256 step 1011b to 1111b = Reserved |

7.6.9 CTRL4 Control Register (address = 0x06)

CTRL4 is shown in [Figure 7-36](#) and described in [Table 7-24](#).

Read/Write

Figure 7-36. CTRL4 Control Register

| 7 | 6 | 5 | 4 | 3 | 2 | 1 | 0 |
|---------|------------|---|---|--------|----------|-----------|--------|
| CLR_FLT | LOCK [2:0] | | | EN_OL | OCP_MODE | OTSD_MODE | TW_REP |
| R/W-0b | R/W-011b | | | R/W-0b | R/W-0b | R/W-0b | R/W-0b |

Table 7-24. CTRL4 Control Register Field Descriptions

| Bit | Field | Type | Default | Description |
|-----|------------|------|---------|--|
| 7 | CLR_FLT | R/W | 0b | Write '1' to this bit to clear all latched fault bits. This bit automatically resets after being written. |
| 6-4 | LOCK [2:0] | R/W | 011b | Write 110b to lock the settings by ignoring further register writes except to these bits and address 0x06h bit 7 (CLR_FLT). Writing any sequence other than 110b has no effect when unlocked. Write 011b to this register to unlock all registers. Writing any sequence other than 011b has no effect when locked. |
| 3 | EN_OL | R/W | 0b | Write '1' to enable open load detection |
| 2 | OCP_MODE | R/W | 0b | 0b = Overcurrent condition causes a latched fault 1b = Overcurrent condition causes an automatic retrying fault |
| 1 | OTSD_MODE | R/W | 0b | 0b = Overtemperature condition will cause latched fault 1b = Overtemperature condition will cause automatic recovery fault |
| 0 | TW_REP | R/W | 0b | 0b = Overtemperature or undertemperature warning is not reported on the nFAULT line 1b = Overtemperature or undertemperature warning is reported on the nFAULT line |

7.6.10 CTRL5 Control Register (address = 0x07)

CTRL5 control is shown in [Figure 7-37](#) and described in [Table 7-25](#).

Read/Write

Figure 7-37. CTRL5 Control Register

| | | | | | | | |
|---------------|---|---|---|---|---|---|---|
| 7 | 6 | 5 | 4 | 3 | 2 | 1 | 0 |
| RSVD | | | | | | | |
| R/W-00001000b | | | | | | | |

Table 7-25. CTRL5 Control Register Field Descriptions

| Bit | Field | Type | Default | Description |
|-----|-------|------|-----------|--|
| 7-0 | RSVD | R/W | 00001000b | Reserved. Should always be '00001000'. |

7.6.11 CTRL6 Control Register (address = 0x08)

CTRL6 is shown in [Figure 7-38](#) and described in [Table 7-26](#).

Read/Write

Figure 7-38. CTRL6 Control Register

| | | | | | | | |
|---------------|---|---|---|---|---|---|---|
| 7 | 6 | 5 | 4 | 3 | 2 | 1 | 0 |
| RSVD | | | | | | | |
| R/W-00001111b | | | | | | | |

Table 7-26. CTRL6 Control Register Field Descriptions

| Bit | Field | Type | Default | Description |
|-----|-------|------|-----------|-------------|
| 7-0 | RSVD | R/W | 00001111b | Reserved. |

7.6.12 CTRL7 Control Register (address = 0x09)

CTRL7 is shown in [Figure 7-39](#) and described in [Table 7-27](#).

Read-only

Figure 7-39. CTRL7 Control Register

| | | | | | | | |
|-------------|---|---|---|---|---|---|---|
| 7 | 6 | 5 | 4 | 3 | 2 | 1 | 0 |
| RSVD | | | | | | | |
| R-11111111b | | | | | | | |

Table 7-27. CTRL7 Control Register Field Descriptions

| Bit | Field | Type | Default | Description |
|-----|-------|------|-----------|-------------|
| 7-0 | RSVD | R | 11111111b | Reserved. |

7.6.13 CTRL8 Control Register (address = 0x0A)

CTRL8 is shown in [Figure 7-40](#) and described in [Table 7-28](#).

Read-only

Figure 7-40. CTRL8 Control Register

| | | | | | | | |
|---------|---|---|---|--------------|---|---|---|
| 7 | 6 | 5 | 4 | 3 | 2 | 1 | 0 |
| RSVD | | | | REV_ID [3:0] | | | |
| R-0000b | | | | R-0010b | | | |

Table 7-28. CTRL8 Control Register Field Descriptions

| Bit | Field | Type | Default | Description |
|-----|-------|------|---------|-------------|
| 7-4 | RSVD | R | 0000b | Reserved |

Table 7-28. CTRL8 Control Register Field Descriptions (continued)

| Bit | Field | Type | Default | Description |
|-----|--------|------|---------|--|
| 3-0 | REV_ID | R | 0010b | Silicon Revision Identification. 0000b indicates 1 st Prototype Revision. 0001b indicates 2 nd Prototype Revision. 0010b indicates Production Revision. |

8 Application and Implementation

Note

Information in the following applications sections is not part of the TI component specification, and TI does not warrant its accuracy or completeness. TI's customers are responsible for determining suitability of components for their purposes. Customers should validate and test their design implementation to confirm system functionality.

8.1 Application Information

The DRV8899-Q1 device is used in bipolar stepper control.

8.2 Typical Application

The following design procedure can be used to configure the DRV8899-Q1 device.

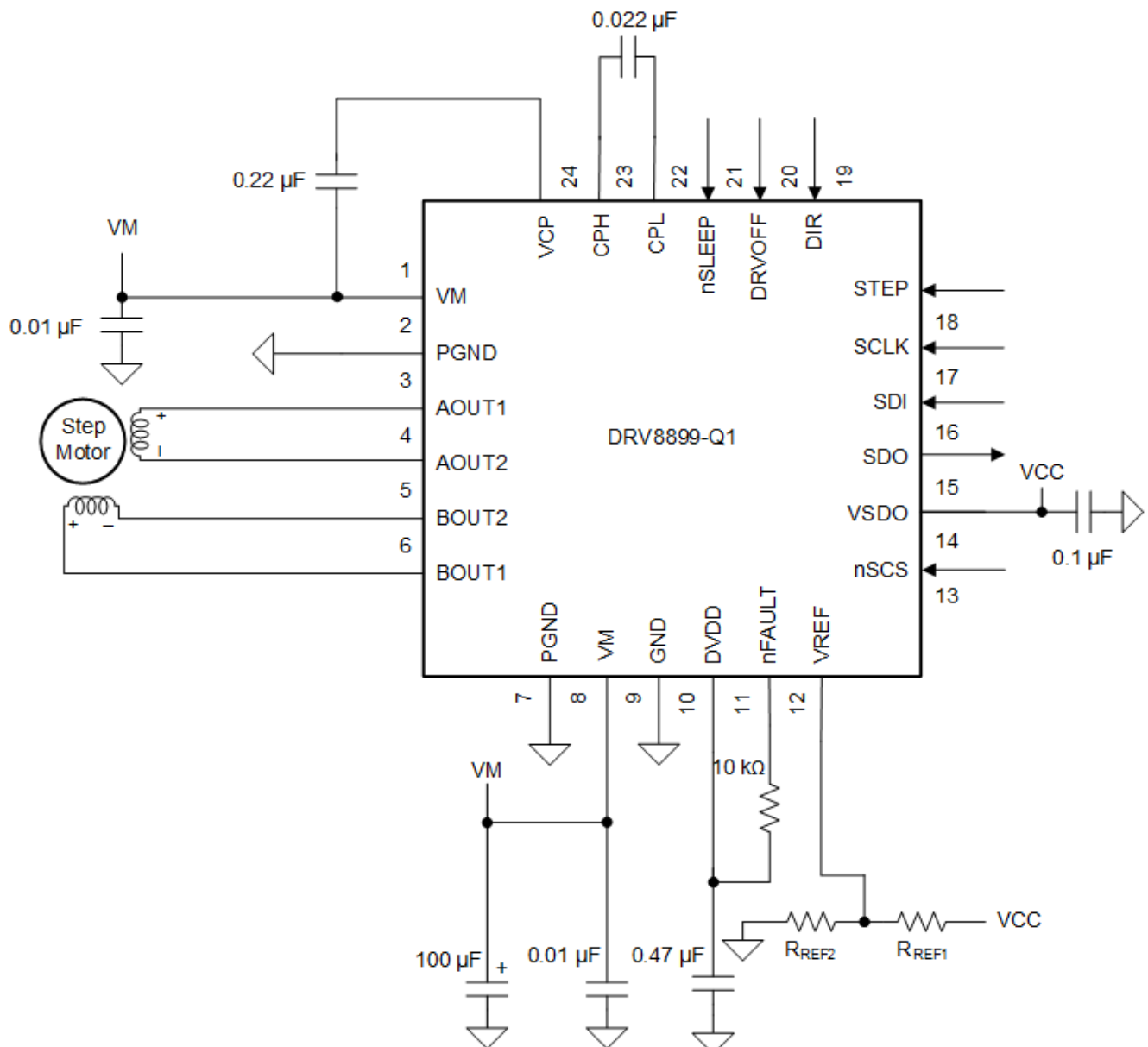

Figure 8-1. Typical Application Schematic (VQFN package)

8.2.1 Design Requirements

Table 8-1 lists the design input parameters for a typical adaptive headlight application.

Table 8-1. Design Parameters

| DESIGN PARAMETER | REFERENCE | EXAMPLE VALUE |
|----------------------------|-------------------|--------------------------------|
| Supply voltage | VM | 9 V to 16 V, 13.5 V Nominal |
| Motor winding resistance | R _L | 7.7 Ω/phase |
| Motor full step angle | θ _{step} | 15°/step |
| Target microstepping level | n _m | 1/8 step |
| Target motor speed | v | 300 rpm |
| Target full-scale current | I _{FS} | 500 mA |

8.2.2 Detailed Design Procedure

8.2.2.1 Stepper Motor Speed

The first step in configuring the device requires the desired motor speed and microstepping level. If the target application requires a constant speed, then a square wave with frequency f_{step} must be applied to the STEP pin. If the target motor speed is too high, the motor does not spin. Make sure that the motor can support the target speed. Use Equation 2 to calculate f_{step} for a desired motor speed (v), microstepping level (n_m), and motor full step angle (θ_{step})

$$f_{\text{step}} \text{ (steps / s)} = \frac{v \text{ (rpm)} \times 360 \text{ (}^\circ \text{ / rot)}}{\theta_{\text{step}} \text{ (}^\circ \text{ / step)} \times n_m \text{ (steps / microstep)} \times 60 \text{ (s / min)}} \quad (2)$$

The value of θ_{step} can be found in the stepper motor data sheet, or written on the motor.

For example, the motor in this adaptive headlight application is required to rotate at 15°/step for a target of 300 rpm at 1/8 microstep mode. Using Equation 2, f_{step} can be calculated as 960 Hz.

For the DRV8899-Q1 device, the microstepping level is set by the MICROSTEP_MODE bits in the SPI register and can be any of the settings listed in Table 8-2. Higher microstepping results in a smoother motor motion and less audible noise, but increases switching losses and requires a higher f_{step} to achieve the same motor speed.

Table 8-2. Microstepping Indexer Settings

| MICROSTEP_MODE | STEP MODE |
|----------------|--|
| 0000b | Full step (2-phase excitation) with 100% current |
| 0001b | Full step (2-phase excitation) with 71% current |
| 0010b | Non-circular 1/2 step |
| 0011b | 1/2 step |
| 0100b | 1/4 step |
| 0101b | 1/8 step |
| 0110b | 1/16 step |
| 0111b | 1/32 step |
| 1000b | 1/64 step |
| 1001b | 1/128 step |
| 1010b | 1/256 step |

8.2.2.2 Current Regulation

In a stepper motor, the full-scale current (I_{FS}) is the maximum current driven through either winding. This quantity depends on the VREF voltage and the TRQ_DAC setting.

The maximum allowable voltage on the VREF pin is 2.2 V. DVDD can be used to provide VREF through a resistor divider.

During stepping, I_{FS} defines the current chopping threshold (I_{TRIP}) for the maximum current step.

$$I_{FS} (A) = \frac{V_{REF} (V)}{K_v (V/A)} \times TRQ_DAC (\%) = \frac{V_{REF} (V) \times TRQ_DAC (\%)}{2.2 (V/A)} \quad (3)$$

8.2.2.3 Decay Modes

The device supports eight different decay modes, as shown in Table 7-7. The current through the motor windings is regulated using an adjustable fixed-time-off scheme which means that after any drive phase, when a motor winding current has hit the current chopping threshold (I_{TRIP}), the device places the winding in one of the eight decay modes for t_{OFF} . After t_{OFF} , a new drive phase starts.

8.2.3 Application Curves

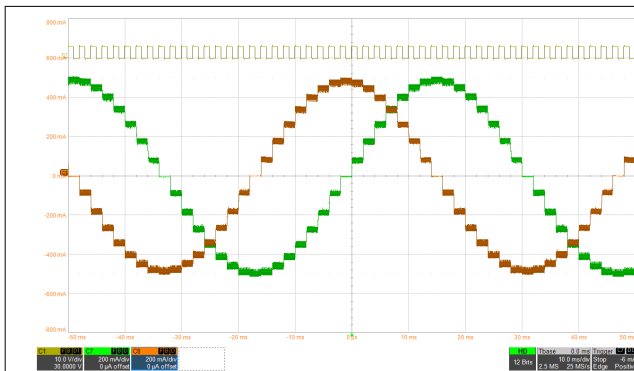

Figure 8-2. 1/8 Microstepping With Mixed30-Mixed30 Decay

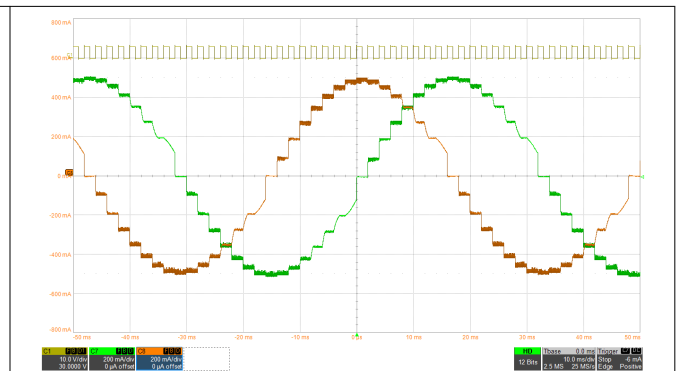

Figure 8-3. 1/8 Microstepping With Slow-Slow Decay

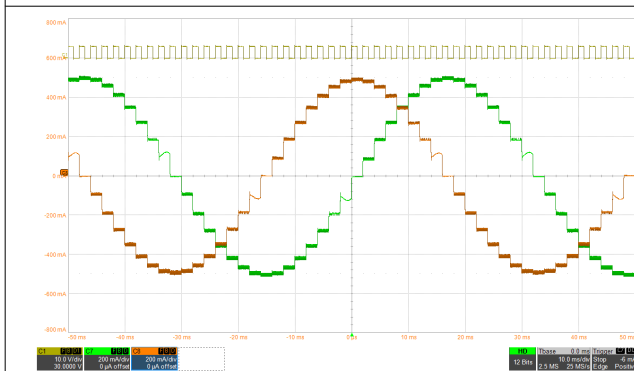

Figure 8-4. 1/8 Microstepping With smart tune Ripple Control Decay

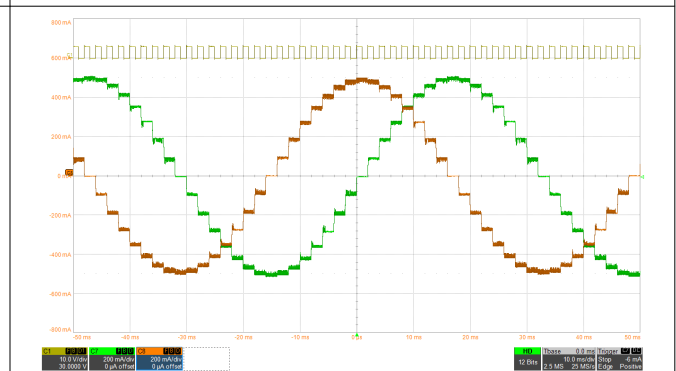

Figure 8-5. 1/8 Microstepping With smart tune Dynamic Decay

8.2.4 Thermal Application

This section presents the power dissipation calculation and junction temperature estimation of the DRV8899-Q1.

8.2.4.1 Power Dissipation

The total power dissipation in the DRV8899-Q1 constitutes of three main components - conduction loss (P_{COND}), switching loss (P_{SW}) and power loss due to quiescent current consumption (P_Q).

8.2.4.1.1 Conduction Loss

The current path for a motor connected in full-bridge is through the high-side FET of one half-bridge and low-side FET of the other half-bridge. The conduction loss (P_{COND}) depends on the motor rms current (I_{RMS}) and high-side ($R_{DS(ONH)}$) and low-side ($R_{DS(ONL)}$) on-state resistances as shown in [Equation 4](#).

$$P_{COND} = 2 \times (I_{RMS})^2 \times (R_{DS(ONH)} + R_{DS(ONL)}) \quad (4)$$

The conduction loss for the typical application shown in [Section 8.2.1](#) is calculated in [Equation 5](#).

$$P_{COND} = 2 \times (I_{RMS})^2 \times (R_{DS(ONH)} + R_{DS(ONL)}) = 2 \times (500\text{-mA} / \sqrt{2})^2 \times (0.6\text{-}\Omega + 0.6\text{-}\Omega) = 300\text{-mW} \quad (5)$$

Note

This power calculation is highly dependent on the device temperature which significantly effects the high-side and low-side on-resistance of the FETs. For more accurate calculation, consider the dependency of on-resistance of FETs with device temperature.

8.2.4.1.2 Switching Loss

The power loss due to the PWM switching frequency depends on the slew rate (t_{SR}), supply voltage, motor RMS current and the PWM switching frequency. The switching losses in each H-bridge during rise-time and fall-time are calculated as shown in [Equation 6](#) and [Equation 7](#).

$$P_{SW_RISE} = 0.5 \times V_{VM} \times I_{RMS} \times t_{RISE_PWM} \times f_{PWM} \quad (6)$$

$$P_{SW_FALL} = 0.5 \times V_{VM} \times I_{RMS} \times t_{FALL_PWM} \times f_{PWM} \quad (7)$$

Both t_{RISE_PWM} and t_{FALL_PWM} can be approximated as V_{VM} / t_{SR} . After substituting the values of various parameters, and assuming 105 V/ μ s slew rate and 30-kHz PWM frequency, the switching losses in each H-bridge are calculated as shown below -

$$P_{SW_RISE} = 0.5 \times 13.5\text{-V} \times (500\text{-mA} / \sqrt{2}) \times (13.5\text{-V} / 105 \text{ V}/\mu\text{s}) \times 30\text{-kHz} = 9.2\text{-mW} \quad (8)$$

$$P_{SW_FALL} = 0.5 \times 13.5\text{-V} \times (500\text{-mA} / \sqrt{2}) \times (13.5\text{-V} / 105 \text{ V}/\mu\text{s}) \times 30\text{-kHz} = 9.2\text{-mW} \quad (9)$$

The total switching loss (P_{SW}) is calculated as twice the sum of rise-time (P_{SW_RISE}) switching loss and fall-time (P_{SW_FALL}) switching loss as shown below -

$$P_{SW} = 2 \times (P_{SW_RISE} + P_{SW_FALL}) = 2 \times (9.2\text{-mW} + 9.2\text{-mW}) = 36.8\text{-mW} \quad (10)$$

Note

The rise-time (t_{RISE}) and the fall-time (t_{FALL}) are calculated based on typical values of the slew rate (t_{SR}). This parameter is expected to change based on the supply-voltage, temperature and device to device variation.

The switching loss is inversely proportional to the output slew rate. 10 V/ μ s slew rate will result in approximately ten times higher switching loss than 105 V/ μ s slew rate. However, lower slew rates tend to result in better EMC performance of the driver. A careful trade-off analysis needs to be performed to arrive at an appropriate slew rate for an application.

The switching loss is directly proportional to the PWM switching frequency. The PWM frequency in an application will depend on the supply voltage, inductance of the motor coil, back emf voltage and OFF time or the ripple current (for smart tune ripple control decay mode).

8.2.4.1.3 Power Dissipation Due to Quiescent Current

The power dissipation due to the quiescent current consumed by the power supply is calculated as shown below -

$$P_Q = V_{VM} \times I_{VM} \quad (11)$$

Substituting the values, quiescent power loss can be calculated as shown below -

$$P_Q = 13.5\text{-V} \times 5\text{-mA} = 67.5\text{-mW} \quad (12)$$

Note

The quiescent power loss is calculated using the typical operating supply current (I_{VM}) which is dependent on supply-voltage, temperature and device to device variation.

8.2.4.1.4 Total Power Dissipation

The total power dissipation (P_{TOT}) is calculated as the sum of conduction loss, switching loss and the quiescent power loss as shown in [Equation 13](#).

$$P_{TOT} = P_{COND} + P_{SW} + P_Q = 300\text{-mW} + 36.8\text{-mW} + 67.5\text{-mW} = 404.3\text{-mW} \quad (13)$$

8.2.4.2 PCB Types

Thermal analysis in this section is focused for the 2-layer and 4-layer PCB with two different copper thickness (1-oz and 2-oz) and six different copper areas (1-cm², 2-cm², 4-cm², 8-cm², 16-cm² and 32-cm²), for both HTSSOP and VQFN packages.

[Figure 8-10](#) and [Figure 8-11](#) show the top-layer which is applicable for both 2/4-layer PCB, for HTSSOP and VQFN packages respectively. The top-layer, mid-layer-1 and bottom-layer of the PCB is filled with ground plane, whereas, the mid-layer-2 is filled with power plane.

For the HTSSOP, 4 x 3 array of thermal vias with 300 μ m drill diameter and 25 μ m Cu plating were placed below the device package. For the VQFN, 2 x 2 array of thermal vias with 300 μ m drill diameter and 25 μ m Cu plating were placed below the device package. Thermal vias contacted top-layer, bottom-layer, and mid-layer-1 (ground plane) if applicable. The mid-layers and the bottom-layer were modeled with size A * A for both 2-layer and 4-layer designs. For the VQFN package, there was no copper on top layer outside of device land area.

The thickness of copper for different PCB layers in different PCB types is summarized in [Table 8-3](#). The PCB dimension (A) for different PCB copper area is summarized in [Table 8-4](#) for the HTSSOP package, and in [Table 8-5](#) for the VQFN package.

Table 8-3. PCB Type and Copper Thickness

| PCB Type | Copper Thickness | Top Layer | Bottom Layer | Mid-Layer 1 | Mid-Layer 2 |
|----------|------------------|-----------|--------------|-------------|-------------|
| 2-Layer | 1-oz PCB | 1-oz | 1-oz | N/A | |
| | 2-oz PCB | 2-oz | 2-oz | | |
| 4-Layer | 1-oz PCB | 1-oz | 1-oz | 1-oz | 1-oz |
| | 2-oz PCB | 2-oz | 2-oz | 1-oz | 1-oz |

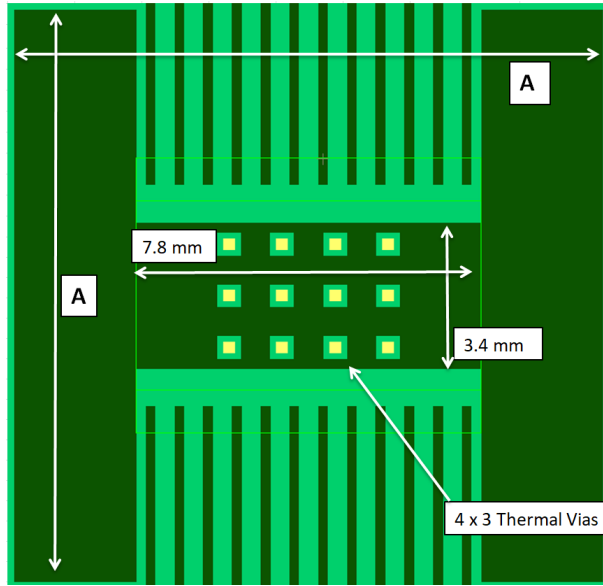

Figure 8-10. PCB - Top Layer (4/2-Layer PCB) for HTSSOP Package

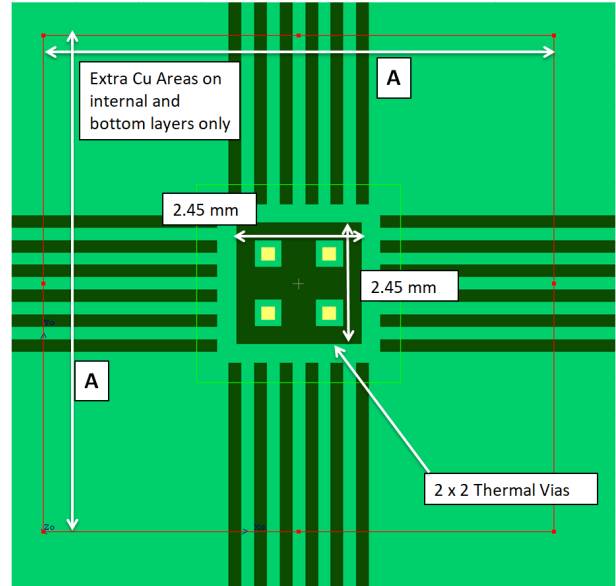

Figure 8-11. PCB - Top Layer (4/2-Layer PCB) for VQFN Package

Table 8-4. PCB Dimension for HTSSOP package

| COPPER AREA (cm ²) | DIMENSION (A) (mm) |
|--------------------------------|--------------------|
| 1 cm ² | 13.31 mm |
| 2 cm ² | 17.64 mm |
| 4 cm ² | 23.62 mm |
| 8 cm ² | 31.98 mm |
| 16 cm ² | 43.76 mm |
| 32 cm ² | 60.36 mm |

Table 8-5. PCB Dimension for VQFN package

| COPPER AREA (cm ²) | DIMENSION (A) (mm) |
|--------------------------------|--------------------|
| 1 cm ² | 10.00 mm |
| 2 cm ² | 14.14 mm |
| 4 cm ² | 20.00 mm |
| 8 cm ² | 28.28 mm |
| 16 cm ² | 40.00 mm |
| 32 cm ² | 56.57 mm |

8.2.4.3 Thermal Parameters for HTSSOP Package

The variation of thermal parameters such as the $R_{\theta JA}$ (Junction-to-Ambient Thermal Resistance) and Ψ_{JB} (Junction-to-Board Characterization Parameter) is highly dependent on the PCB type, package type, copper thickness and the copper pad area.

Figure 8-12 and Figure 8-13 show the variation of the $R_{\theta JA}$ (Junction-to-Ambient Thermal Resistance) and Ψ_{JB} (Junction-to-Board Characterization Parameter) with copper-pad area for 2-layer PCB, for the HTSSOP package. As shown in these curves, the thermal resistance is lower for the higher copper thickness PCB and the higher copper pad-area.

Similarly, Figure 8-14 and Figure 8-15 show the variation of the $R_{\theta JA}$ and Ψ_{JB} with copper-pad area for 4-layer PCB respectively, for the HTSSOP package.

Note

The thermal parameters ($R_{\theta JA}$ (Junction-to-Ambient Thermal Resistance) and Ψ_{JB} (Junction-to-Board Characterization Parameter)) are calculated considering the ambient temperature of 25°C and with 2-W power evenly dissipated between high-side and low-side FET's. The thermal parameters calculated considering the power dissipation at the actual location of the power-FETs rather than an averaged estimation.

The thermal parameters are highly dependent on the external conditions such as altitude, package geometry etc. Refer to [Application Report](#) for more details.

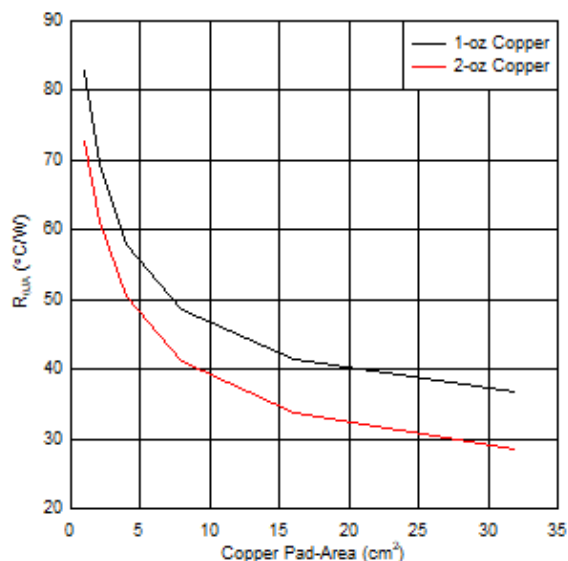

Figure 8-12. 2-Layer PCB Junction-to-Ambient Thermal Resistance ($R_{\theta JA}$) vs Copper Area

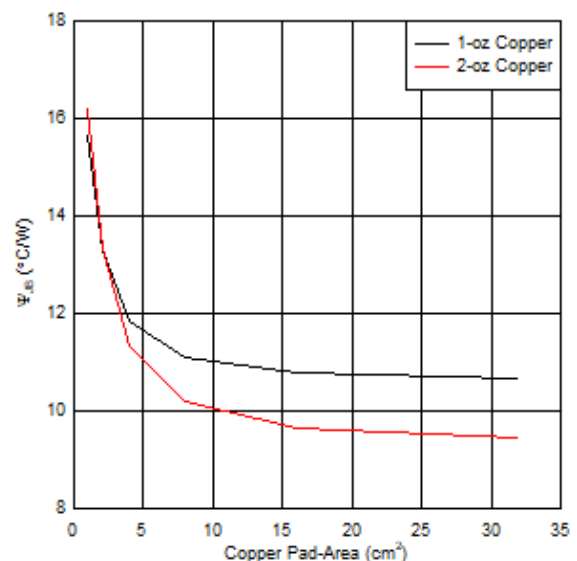
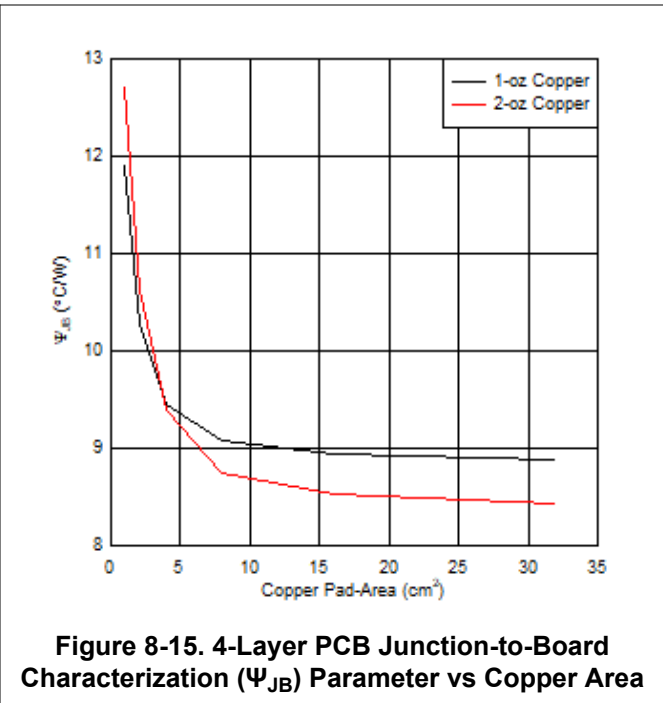
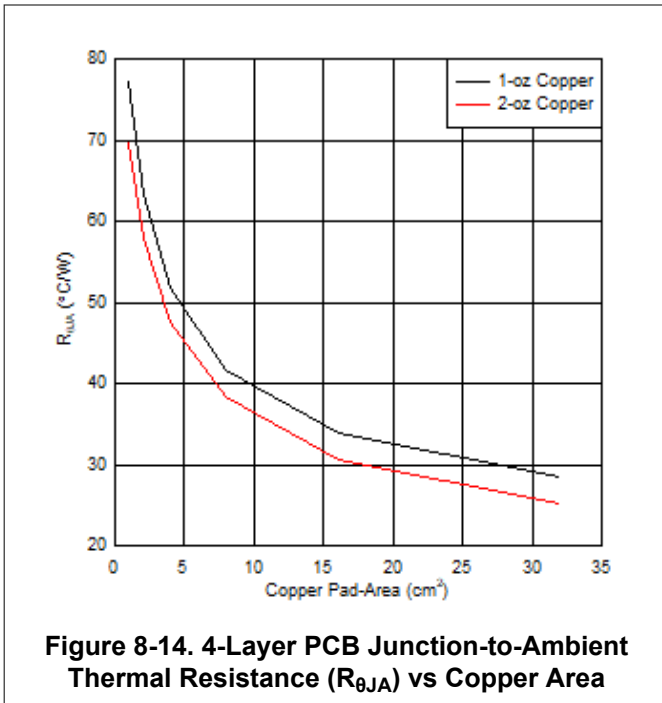

Figure 8-13. 2-Layer PCB Junction-to-Board Characterization Parameter (Ψ_{JB}) vs Copper Area



8.2.4.4 Thermal Parameters for VQFN Package

Figure 8-16 and Figure 8-17 show the variation of the $R_{\theta JA}$ (Junction-to-Ambient Thermal Resistance) and Ψ_{JB} (Junction-to-Board Characterization Parameter) with copper-pad area for 2-layer PCB, for the VQFN package. As shown in these curves, the thermal resistance is lower for the higher copper thickness PCB and the higher copper pad-area.

Similarly, Figure 8-18 and Figure 8-19 show the variation of the $R_{\theta JA}$ and Ψ_{JB} with copper-pad area for 4-layer PCB respectively, for the VQFN package.

Note

The thermal parameters ($R_{\theta JA}$ (Junction-to-Ambient Thermal Resistance) and Ψ_{JB} (Junction-to-Board Characterization Parameter)) are calculated considering the ambient temperature of 25°C and with 2-W power evenly dissipated between high-side and low-side FET's. The thermal parameters calculated considering the power dissipation at the actual location of the power-FETs rather than an averaged estimation.

The thermal parameters are highly dependent on the external conditions such as altitude, package geometry etc. Refer to [Application Report](#) for more details.

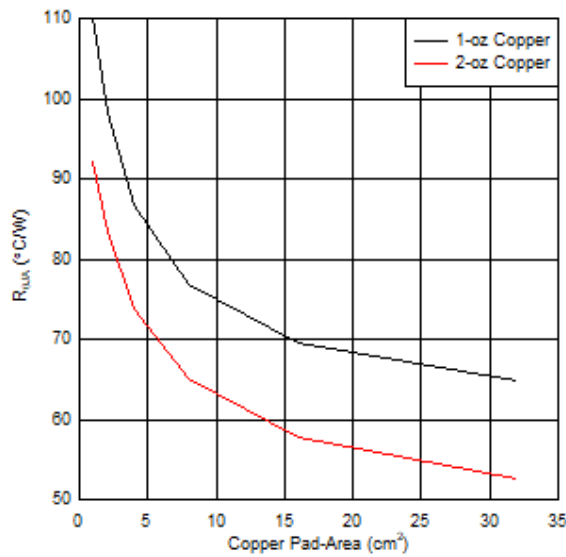

Figure 8-16. 2-Layer PCB Junction-to-Ambient Thermal Resistance (R_{θJA}) vs Copper Area

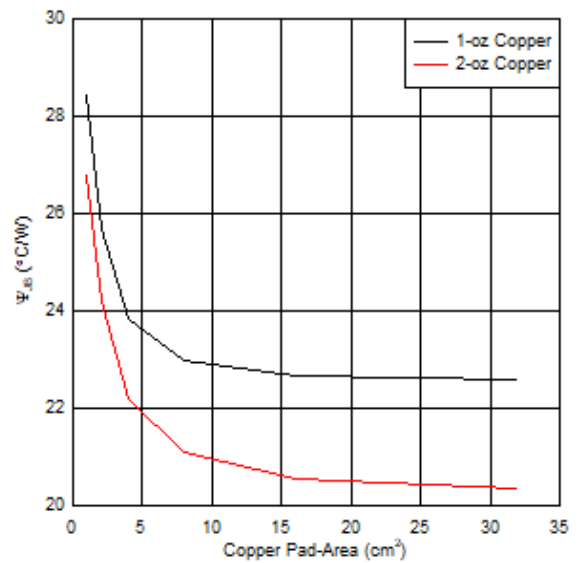

Figure 8-17. 2-Layer PCB Junction-to-Board Characterization Parameter (Ψ_{JB}) vs Copper Area

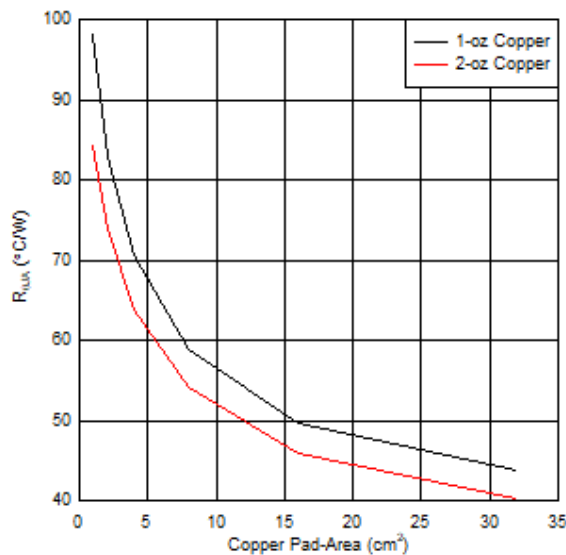

Figure 8-18. 4-Layer PCB Junction-to-Ambient Thermal Resistance (R_{θJA}) vs Copper Area

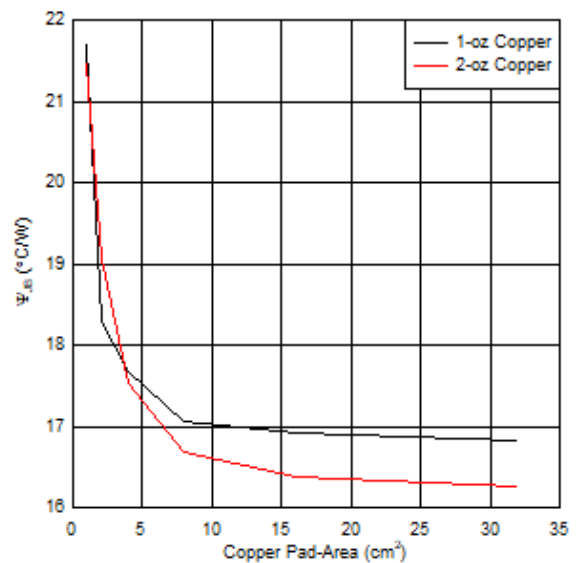

Figure 8-19. 4-Layer PCB Junction-to-Board Characterization (Ψ_{JB}) Parameter vs Copper Area

8.2.4.5 Device Junction Temperature Estimation

For an ambient temperature of T_A and total power dissipation (P_{TOT}), the junction temperature (T_J) is calculated as shown in the following equation. T_J = T_A + (P_{TOT} × R_{θJA})

Considering a JEDEC standard 4-layer PCB, the junction-to-ambient thermal resistance (R_{θJA}) is 40.7 °C/W for the VQFN package.

The junction temperature is calculated as shown below -

$$T_J = 25^{\circ}\text{C} + (0.4043\text{-W} \times 40.7^{\circ}\text{C/W}) = 41.46^{\circ}\text{C} \tag{14}$$

9 Power Supply Recommendations

The device is designed to operate from an input voltage supply (VM) range from 4.5 V to 45 V. A 0.01- μF ceramic capacitor rated for VM must be placed at each VM pin as close to the device as possible. In addition, a bulk capacitor must be included on VM.

9.1 Bulk Capacitance

Having appropriate local bulk capacitance is an important factor in motor drive system design. It is generally beneficial to have more bulk capacitance, while the disadvantages are increased cost and physical size.

The amount of local capacitance needed depends on a variety of factors, including:

- The highest current required by the motor system
- The power supply's capacitance and ability to source current
- The amount of parasitic inductance between the power supply and motor system
- The acceptable voltage ripple
- The type of motor used (brushed DC, brushless DC, stepper)
- The motor braking method

The inductance between the power supply and motor drive system will limit the rate current can change from the power supply. If the local bulk capacitance is too small, the system will respond to excessive current demands or dumps from the motor with a change in voltage. When adequate bulk capacitance is used, the motor voltage remains stable and high current can be quickly supplied.

The data sheet generally provides a recommended value, but system-level testing is required to determine the appropriate sized bulk capacitor.

The voltage rating for bulk capacitors should be higher than the operating voltage, to provide margin for cases when the motor transfers energy to the supply.

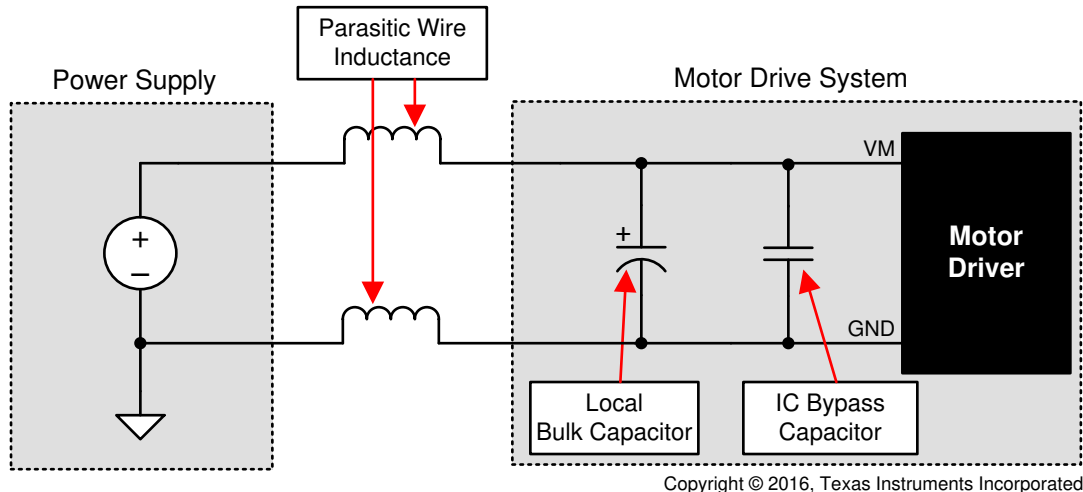

Copyright © 2016, Texas Instruments Incorporated

Figure 9-1. Example Setup of Motor Drive System With External Power Supply

10 Layout

10.1 Layout Guidelines

The VM pin should be bypassed to GND using a low-ESR ceramic bypass capacitor with a recommended value of 0.01 μF rated for VM. This capacitor should be placed as close to the VM pin as possible with a thick trace or ground plane connection to the device GND pin.

The VM pin must be bypassed to ground using a bulk capacitor rated for VM. This component can be an electrolytic capacitor.

A low-ESR ceramic capacitor must be placed in between the CPL and CPH pins. A value of 0.022 μF rated for VM is recommended. Place this component as close to the pins as possible.

A low-ESR ceramic capacitor must be placed in between the VM and VCP pins. A value of 0.22 μF rated for 16 V is recommended. Place this component as close to the pins as possible.

Bypass the DVDD pin to ground with a low-ESR ceramic capacitor. A value of 0.47 μF rated for 6.3 V is recommended. Place this bypassing capacitor as close to the pin as possible.

The thermal PAD must be connected to system ground.

10.2 Layout Example

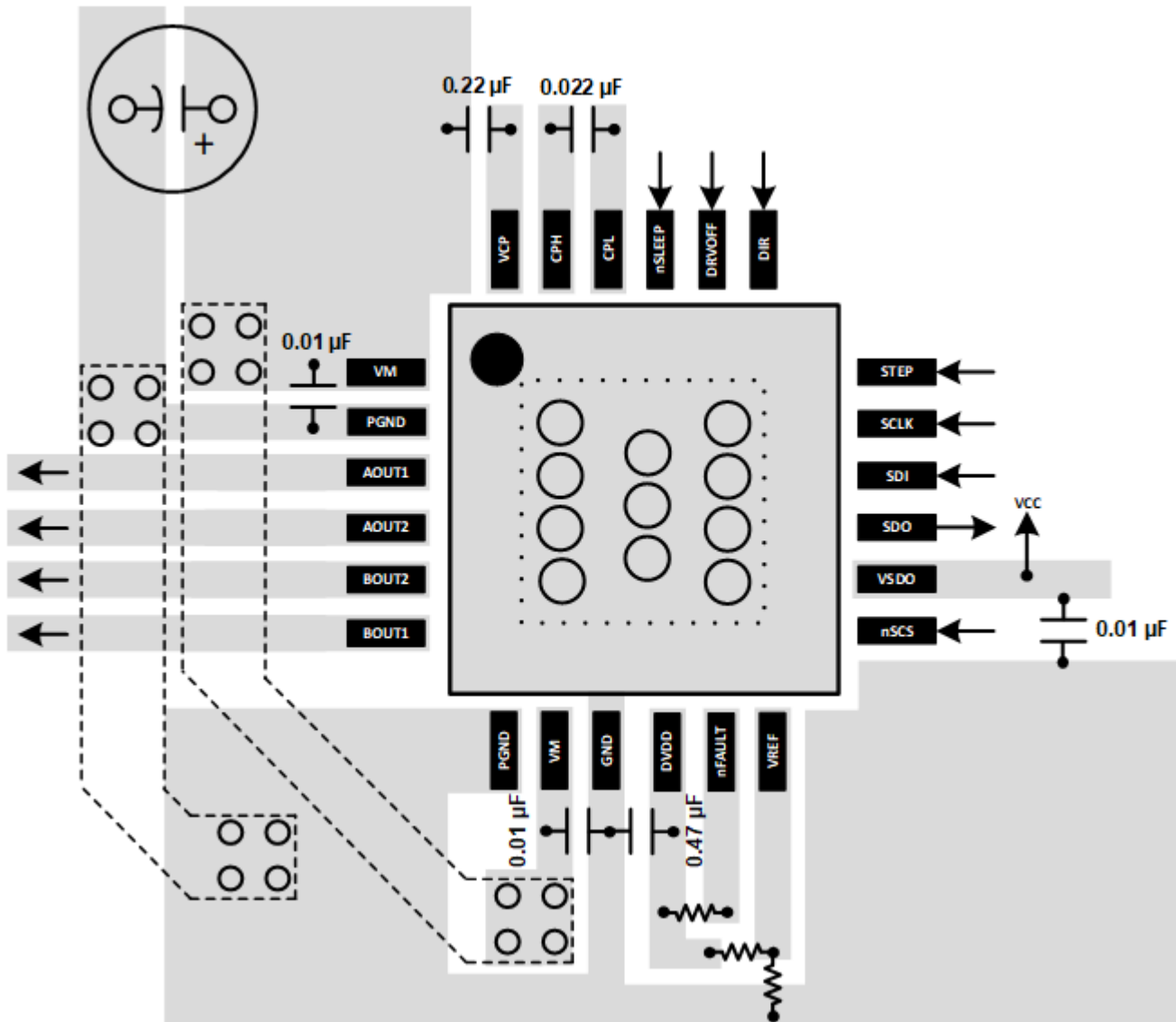

Figure 10-1. QFN Layout Recommendation

11 Device and Documentation Support

11.1 Documentation Support

11.1.1 Related Documentation

For related documentation see the following:

- Texas Instruments, [DRV8899-Q1 Functional Safety FIT Rate, FMD and Pin FMA](#)
- Texas Instruments, [Calculating Motor Driver Power Dissipation](#) application report
- Texas Instruments, [Current Recirculation and Decay Modes](#) application report
- Texas Instruments, [How AutoTune™ regulates current in stepper motors](#) white paper
- Texas Instruments, [Industrial Motor Drive Solution Guide](#)
- Texas Instruments, [PowerPAD™ Made Easy](#) application report
- Texas Instruments, [PowerPAD™ Thermally Enhanced Package](#) application report
- Texas Instruments, [Stepper motors made easy with AutoTune™](#) white paper
- Texas Instruments, [Understanding Motor Driver Current Ratings](#) application report
- Texas Instruments, [Motor Drives Layout Guide](#) application report
- Texas Instruments, [DRV8899-Q1 Evaluation Module \(EVM\)](#) tool folder

11.2 Receiving Notification of Documentation Updates

To receive notification of documentation updates, navigate to the device product folder on ti.com. Click on *Subscribe to updates* to register and receive a weekly digest of any product information that has changed. For change details, review the revision history included in any revised document.

11.3 Support Resources

[TI E2E™ support forums](#) are an engineer's go-to source for fast, verified answers and design help — straight from the experts. Search existing answers or ask your own question to get the quick design help you need.

Linked content is provided "AS IS" by the respective contributors. They do not constitute TI specifications and do not necessarily reflect TI's views; see TI's [Terms of Use](#).

11.4 Trademarks

TI E2E™ is a trademark of Texas Instruments.

All trademarks are the property of their respective owners.

11.5 Electrostatic Discharge Caution



This integrated circuit can be damaged by ESD. Texas Instruments recommends that all integrated circuits be handled with appropriate precautions. Failure to observe proper handling and installation procedures can cause damage.

ESD damage can range from subtle performance degradation to complete device failure. Precision integrated circuits may be more susceptible to damage because very small parametric changes could cause the device not to meet its published specifications.

11.6 Glossary

[TI Glossary](#) This glossary lists and explains terms, acronyms, and definitions.

12 Mechanical, Packaging, and Orderable Information

The following pages include mechanical, packaging, and orderable information. This information is the most current data available for the designated devices. This data is subject to change without notice and revision of this document. For browser-based versions of this data sheet, refer to the left-hand navigation.

RGE0024N

PACKAGE OUTLINE
VQFN - 1 mm max height

PLASTIC QUAD FLATPACK-NO LEAD

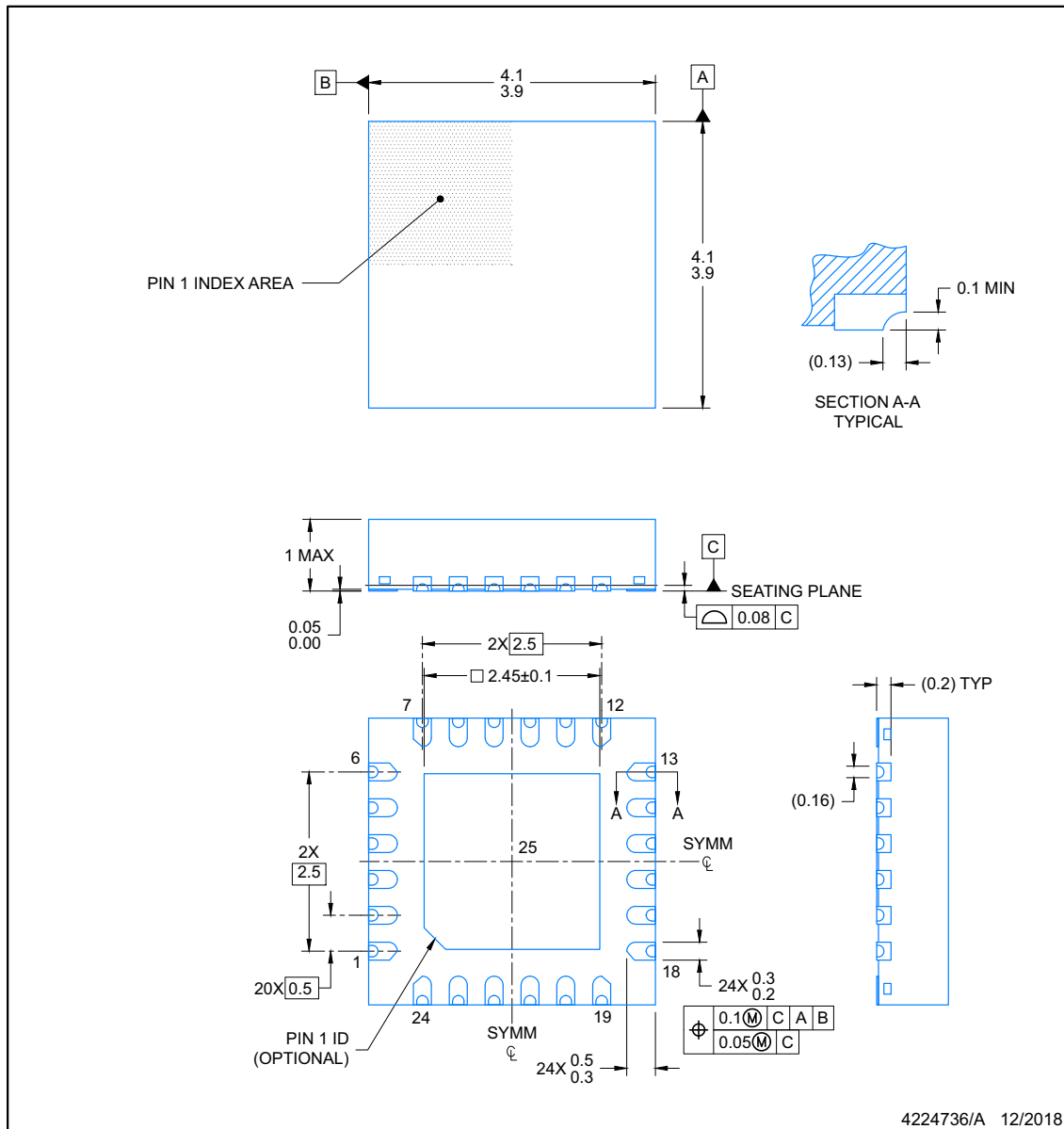

NOTES:

1. All linear dimensions are in millimeters. Any dimensions in parenthesis are for reference only. Dimensioning and tolerancing per ASME Y14.5M.
2. This drawing is subject to change without notice.
3. The package thermal pad must be soldered to the printed circuit board for optimal thermal and mechanical performance.

EXAMPLE BOARD LAYOUT

VQFN - 1 mm max height

RGE0024N

PLASTIC QUAD FLATPACK-NO LEAD

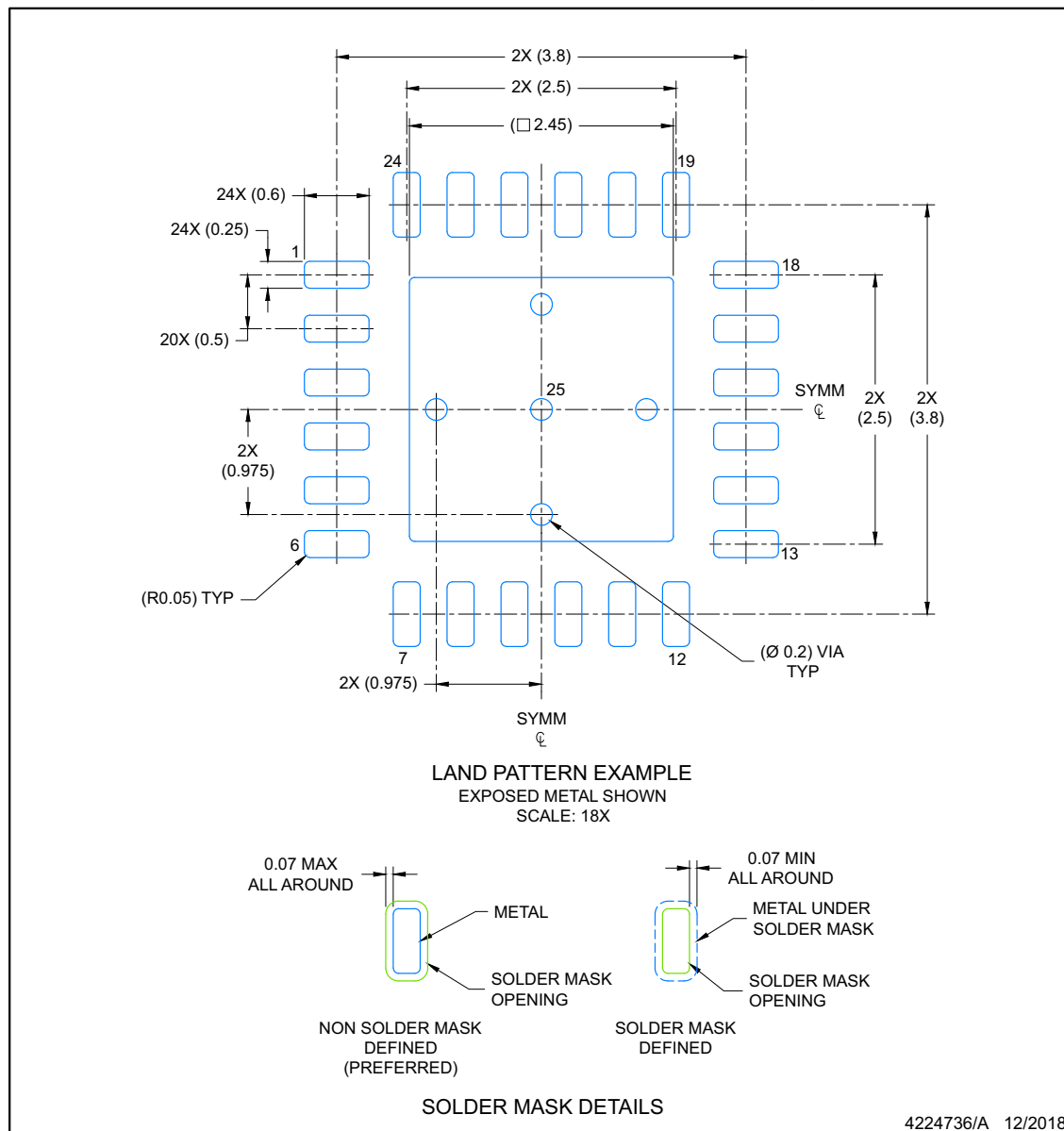

NOTES: (continued)

4. This package is designed to be soldered to a thermal pad on the board. For more information, see Texas Instruments literature number SLUA271 (www.ti.com/lit/sluea271).
5. Vias are optional depending on application, refer to device data sheet. If any vias are implemented, refer to their locations shown on this view. It is recommended that vias under paste be filled, plugged or tented.

EXAMPLE STENCIL DESIGN

RGE0024N

VQFN - 1 mm max height

PLASTIC QUAD FLATPACK-NO LEAD

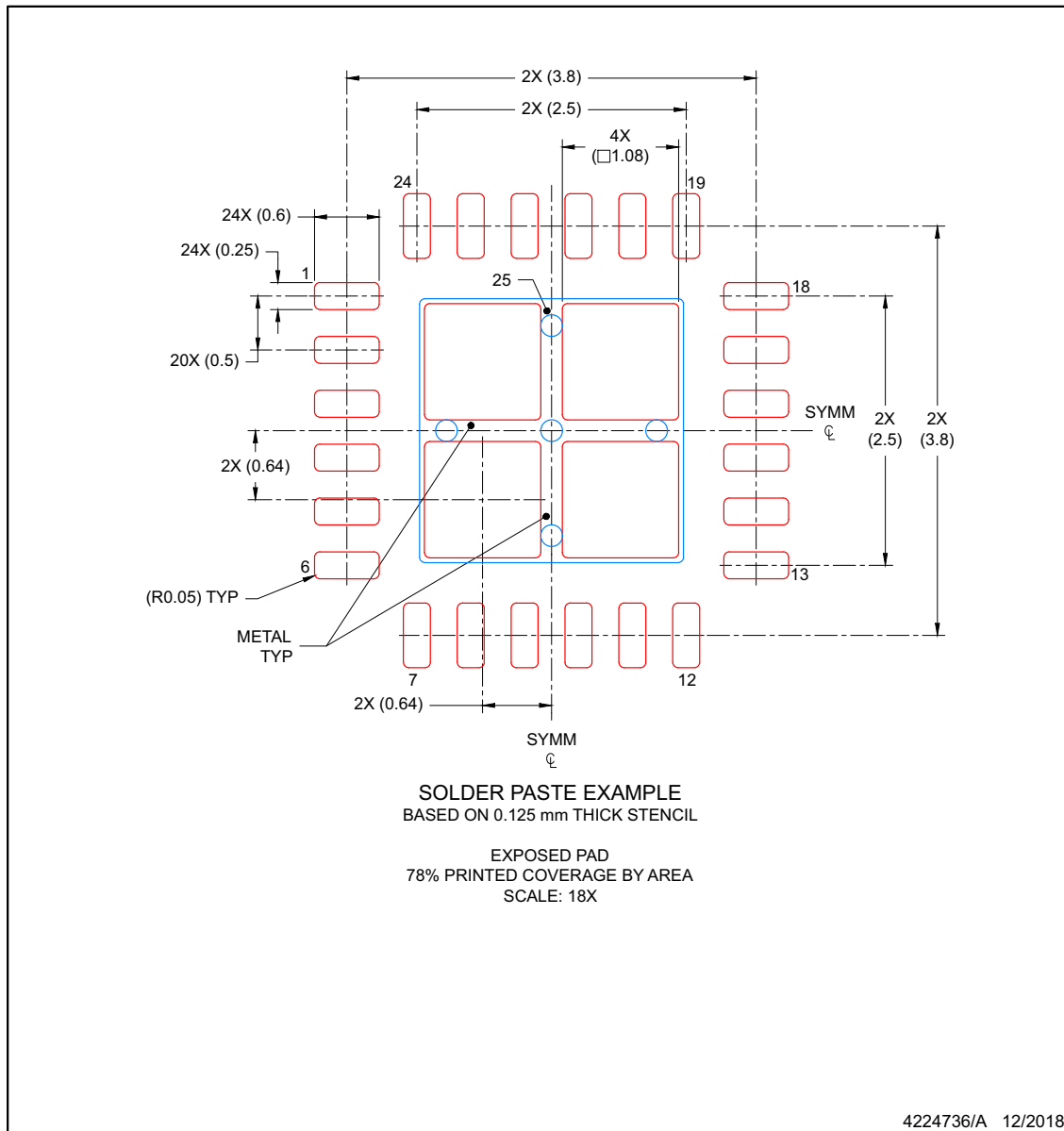

NOTES: (continued)

6. Laser cutting apertures with trapezoidal walls and rounded corners may offer better paste release. IPC-7525 may have alternate design recommendations.

PACKAGING INFORMATION

| Orderable Device | Status (1) | Package Type | Package Drawing | Pins | Package Qty | Eco Plan (2) | Lead finish/ Ball material (6) | MSL Peak Temp (3) | Op Temp (°C) | Device Marking (4/5) | Samples |
|------------------|---------------|--------------|-----------------|------|-------------|-----------------|--------------------------------------|----------------------|--------------|-------------------------|---|
| DRV8899QWRGERQ1 | ACTIVE | VQFN | RGE | 24 | 3000 | RoHS & Green | NIPDAU | Level-2-260C-1 YEAR | -40 to 125 | DRV 8899 |  |

(1) The marketing status values are defined as follows:

ACTIVE: Product device recommended for new designs.

LIFEBUY: TI has announced that the device will be discontinued, and a lifetime-buy period is in effect.

NRND: Not recommended for new designs. Device is in production to support existing customers, but TI does not recommend using this part in a new design.

PREVIEW: Device has been announced but is not in production. Samples may or may not be available.

OBsolete: TI has discontinued the production of the device.

(2) **RoHS:** TI defines "RoHS" to mean semiconductor products that are compliant with the current EU RoHS requirements for all 10 RoHS substances, including the requirement that RoHS substance do not exceed 0.1% by weight in homogeneous materials. Where designed to be soldered at high temperatures, "RoHS" products are suitable for use in specified lead-free processes. TI may reference these types of products as "Pb-Free".

RoHS Exempt: TI defines "RoHS Exempt" to mean products that contain lead but are compliant with EU RoHS pursuant to a specific EU RoHS exemption.

Green: TI defines "Green" to mean the content of Chlorine (Cl) and Bromine (Br) based flame retardants meet JS709B low halogen requirements of <=100ppm threshold. Antimony trioxide based flame retardants must also meet the <=1000ppm threshold requirement.

(3) MSL, Peak Temp. - The Moisture Sensitivity Level rating according to the JEDEC industry standard classifications, and peak solder temperature.

(4) There may be additional marking, which relates to the logo, the lot trace code information, or the environmental category on the device.

(5) Multiple Device Markings will be inside parentheses. Only one Device Marking contained in parentheses and separated by a "~" will appear on a device. If a line is indented then it is a continuation of the previous line and the two combined represent the entire Device Marking for that device.

(6) Lead finish/Ball material - Orderable Devices may have multiple material finish options. Finish options are separated by a vertical ruled line. Lead finish/Ball material values may wrap to two lines if the finish value exceeds the maximum column width.

Important Information and Disclaimer:The information provided on this page represents TI's knowledge and belief as of the date that it is provided. TI bases its knowledge and belief on information provided by third parties, and makes no representation or warranty as to the accuracy of such information. Efforts are underway to better integrate information from third parties. TI has taken and continues to take reasonable steps to provide representative and accurate information but may not have conducted destructive testing or chemical analysis on incoming materials and chemicals. TI and TI suppliers consider certain information to be proprietary, and thus CAS numbers and other limited information may not be available for release.

In no event shall TI's liability arising out of such information exceed the total purchase price of the TI part(s) at issue in this document sold by TI to Customer on an annual basis.

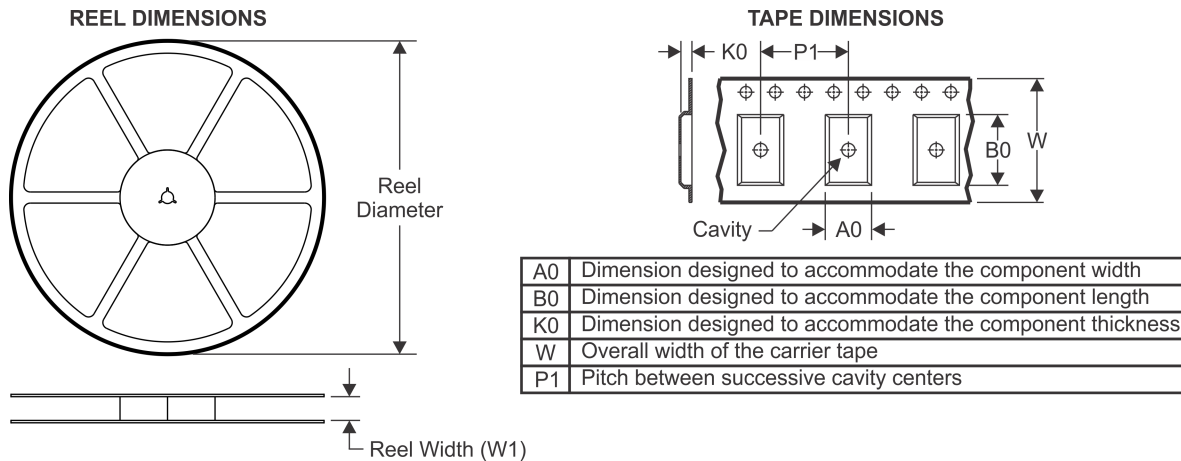
TAPE AND REEL INFORMATION

QUADRANT ASSIGNMENTS FOR PIN 1 ORIENTATION IN TAPE

*All dimensions are nominal

| Device | Package Type | Package Drawing | Pins | SPQ | Reel Diameter (mm) | Reel Width W1 (mm) | A0 (mm) | B0 (mm) | K0 (mm) | P1 (mm) | W (mm) | Pin1 Quadrant |
|-----------------|--------------|-----------------|------|------|--------------------|--------------------|---------|---------|---------|---------|--------|---------------|
| DRV8899QWRGERQ1 | VQFN | RGE | 24 | 3000 | 330.0 | 12.4 | 4.25 | 4.25 | 1.15 | 8.0 | 12.0 | Q2 |

TAPE AND REEL BOX DIMENSIONS



*All dimensions are nominal

| Device | Package Type | Package Drawing | Pins | SPQ | Length (mm) | Width (mm) | Height (mm) |
|-----------------|--------------|-----------------|------|------|-------------|------------|-------------|
| DRV8899QWRGERQ1 | VQFN | RGE | 24 | 3000 | 367.0 | 367.0 | 35.0 |

RGE 24

GENERIC PACKAGE VIEW

VQFN - 1 mm max height

PLASTIC QUAD FLATPACK - NO LEAD

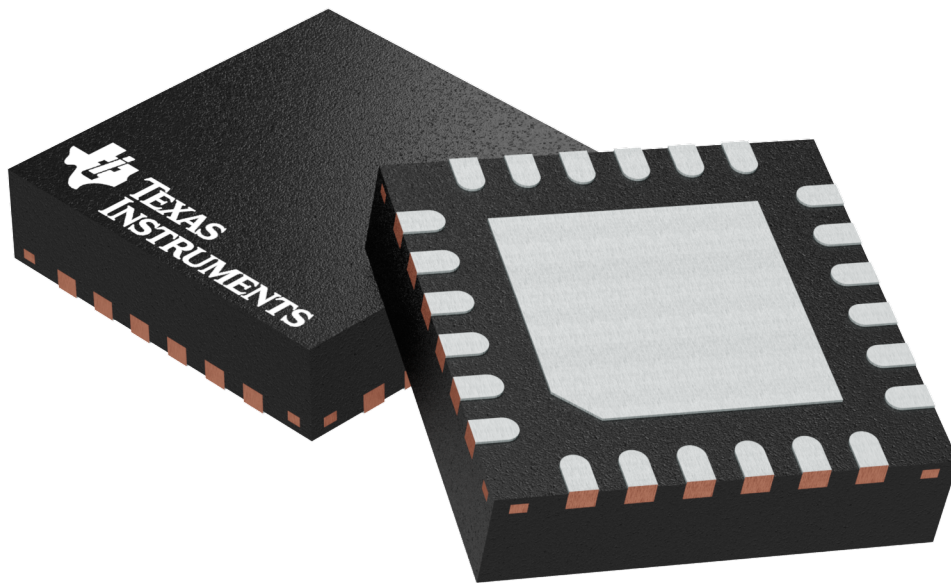

Images above are just a representation of the package family, actual package may vary.
Refer to the product data sheet for package details.

4204104/H

IMPORTANT NOTICE AND DISCLAIMER

TI PROVIDES TECHNICAL AND RELIABILITY DATA (INCLUDING DATASHEETS), DESIGN RESOURCES (INCLUDING REFERENCE DESIGNS), APPLICATION OR OTHER DESIGN ADVICE, WEB TOOLS, SAFETY INFORMATION, AND OTHER RESOURCES "AS IS" AND WITH ALL FAULTS, AND DISCLAIMS ALL WARRANTIES, EXPRESS AND IMPLIED, INCLUDING WITHOUT LIMITATION ANY IMPLIED WARRANTIES OF MERCHANTABILITY, FITNESS FOR A PARTICULAR PURPOSE OR NON-INFRINGEMENT OF THIRD PARTY INTELLECTUAL PROPERTY RIGHTS.

These resources are intended for skilled developers designing with TI products. You are solely responsible for (1) selecting the appropriate TI products for your application, (2) designing, validating and testing your application, and (3) ensuring your application meets applicable standards, and any other safety, security, or other requirements. These resources are subject to change without notice. TI grants you permission to use these resources only for development of an application that uses the TI products described in the resource. Other reproduction and display of these resources is prohibited. No license is granted to any other TI intellectual property right or to any third party intellectual property right. TI disclaims responsibility for, and you will fully indemnify TI and its representatives against, any claims, damages, costs, losses, and liabilities arising out of your use of these resources.

TI's products are provided subject to TI's Terms of Sale (<https://www.ti.com/legal/termsofsale.html>) or other applicable terms available either on [ti.com](https://www.ti.com) or provided in conjunction with such TI products. TI's provision of these resources does not expand or otherwise alter TI's applicable warranties or warranty disclaimers for TI products.

Mailing Address: Texas Instruments, Post Office Box 655303, Dallas, Texas 75265
Copyright © 2021, Texas Instruments Incorporated