

采用小型封装且具有 ±15kV IEC ESD 保护功能的 TRSF3221E 3V 至 5.5V 单通道 RS-232 1Mbit/s 线路驱动器和接收器

1 特性

- 为 RS-232 引脚提供 ESD 保护
 - ±15kV 人体放电模型 (HBM)
 - ±8kV IEC 61000-4-2 接触放电
 - ±15kV IEC 61000-4-2 气隙放电
- 由 3V 至 5.5V V_{CC} 电源供电
- 速率高达 1Mbit/s
 - 低速引脚兼容器件 (250kbit/s) - TRS3221E
- 采用近似于芯片级封装的 16 引脚 VQFN (RGT, 比 TSSOP 封装小 82%)
- 低待机电流: 1 μA (典型值)
- 外部电容器: 4 × 0.1 μF
- 接受 5V 逻辑输入及 3.3V 电源
- 自动断电功能可自动禁用驱动器以节省能耗

2 应用

- 工业 PC
- 有线网络
- 数据中心和企业级计算
- 电池供电型系统
- PDA
- 笔记本电脑
- 便携式计算机
- 掌上电脑
- 手持设备

3 说明

TRSF3221E 包含一个线路驱动器、一个线路接收器和一个具有引脚对引脚 (串行端口连接引脚, 包括 GND) ±15kV IEC ESD 保护功能的双电荷泵电路。TRSF3221E 可在异步通信控制器和串行端口连接器之间提供电气接口。电荷泵和四个小型外部电容器支持由 3V 至 5.5V 单电源供电。TRSF3221E 以高达 1Mbit/s 的数据信号传输速率运行, 驱动器输出电压摆率为 24V/μs 至 150V/μs。

串行端口处于非活动状态时, 可提供灵活的电源管理控制选项。当 FORCEON 为低电平且 FORCEOFF 为高电平时, 自动断电功能启用。在这种运行模式下, 如果 TRSF3221E 在接收器输入端未感应到有效的 RS-232 信号, 则会禁用驱动器输出。如果 FORCEOFF 设定为低电平且使能 (EN) 输入为高电平, 则驱动器和接收器均关闭, 且电源电流降低至 1 μA。断开串行端口的连接或关闭外围驱动器会导致发生自动断电情况。当 FORCEON 和 FORCEOFF 均为高电平时可禁用自动断电。启用自动断电的情况下, 向接收器输入施加有效信号时, 器件会自动激活。INVALID 输出会通知用户接收器输入端是否存在 RS-232 信号。如果接收器输入电压大于 2.7V 或小于 -2.7V, 或者介于 -0.3V 至 0.3V 之间的时间少于 30 μs, 则 INVALID 为高电平 (有效数据)。如果接收器输入电压在 -0.3V 至 0.3V 之间的时间超过 30 μs, 则 INVALID 为低电平 (无效数据)。

有关接收器输入电平的信息, 请参阅图 7-5。

器件信息

器件型号	封装 ⁽¹⁾	封装尺寸 (标称值)
TRSF3221E	DB (SSOP)	6.20mm x 5.30mm
	PW (TSSOP)	5.00mm x 4.40mm
	RGT (VQFN)	3.00mm x 3.00mm

(1) 如需了解所有可用封装, 请参阅数据表末尾的可订购产品附录。

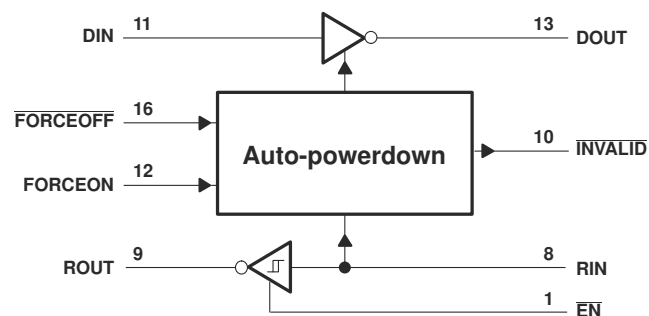

逻辑图 (正逻辑)



Table of Contents

1 特性	1	8 Detailed Description	12
2 应用	1	8.1 Overview.....	12
3 说明	1	8.2 Functional Block Diagram.....	12
4 Revision History	2	8.3 Feature Description.....	12
5 Pin Configuration and Functions	3	8.4 Device Functional Modes.....	13
6 Specifications	4	9 Application and Implementation	14
6.1 Absolute Maximum Ratings.....	4	9.1 Application Information.....	14
6.2 ESD Ratings.....	4	10 Power Supply Recommendations	15
6.3 ESD Ratings, IEC Specifications.....	4	11 Layout	16
6.4 Recommended Operating Conditions.....	5	11.1 Layout Guidelines.....	16
6.5 Thermal Resistance Characteristics.....	5	11.2 Layout Example.....	16
6.6 Electrical Characteristics.....	5	12 Device and Documentation Support	17
6.7 Electrical Characteristics, Driver.....	6	12.1 接收文档更新通知.....	17
6.8 Switching Characteristics, Driver.....	6	12.2 支持资源.....	17
6.9 Electrical Characteristics, Receiver.....	7	12.3 Trademarks.....	17
6.10 Switching Characteristics, Receiver.....	7	12.4 Electrostatic Discharge Caution.....	17
6.11 Electrical Characteristics, Auto-Powerdown.....	8	12.5 术语表.....	17
6.12 Switching Characteristics, Auto-Powerdown.....	8	13 Mechanical, Packaging, and Orderable Information	17
6.13 Typical Characteristics.....	8		
7 Parameter Measurement Information	9		

4 Revision History

注：以前版本的页码可能与当前版本的页码不同

Changes from Revision A (May 2021) to Revision B (July 2021)	Page
• 更改了 <i>应用</i> 列表.....	1
• Changed the table note for the <i>ESD Ratings - IEC Specifications</i> table to make it also applicable to PW package.....	4
• Changed the thermal information for PW package.....	5

Changes from Revision * (August 2007) to Revision A (May 2021)	Page
• 添加了“器件信息”表、“ESD 等级”表、“特性说明”部分、“器件功能模式”、“应用和实施”部分、“电源相关建议”部分、“布局”部分、“器件和文档支持”部分以及“机械、封装和可订购信息”部分.....	1

5 Pin Configuration and Functions



表 5-1. Pin Functions

NAME	PIN		I/O ⁽¹⁾	DESCRIPTION
	DB or PW	RGT		
EN	1	14	--	
C1+	2	16	-	Positive lead of C1 capacitor
V+	3	15	O	Positive charge pump output for storage capacitor only
C1-	4	1	-	Negative lead of C1 capacitor
C2+	5	2	-	Positive lead of C2 capacitor
C2-	6	3	-	Negative lead of C2 capacitor
V-	7	4	O	Negative charge pump output for storage capacitor only
RIN	8	5	I	RS232 line data input (from remote RS232 system)
ROUT	9	6	O	Logic data output (to UART)
INVALID	10	7		
DIN	11	8	I	Logic data input (from UART)
FORCEON	12	9		
DOUT	13	10	O	RS232 line data output (to remote RS232 system)
GRD	14	11	-	Ground
V _{CC}	15	12	-	Supply Voltage, Connect to external 3-V to 5.5-V power supply
FORCEOFF	16	13		
Thermal Pad	-	Yes	-	Exposed thermal pad. Can be connected to GND or left floating.

(1) Signal Types: I = Input, O = Output, I/O = Input or Output.

6 Specifications

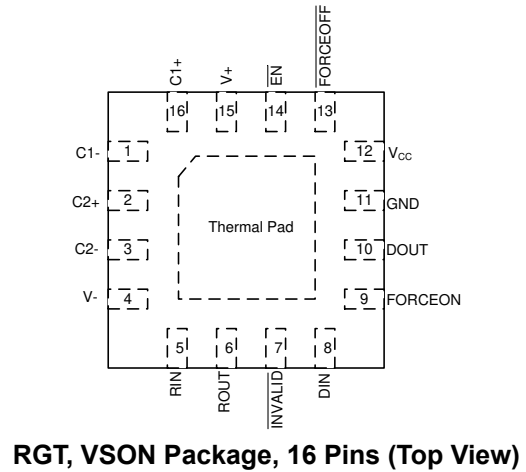
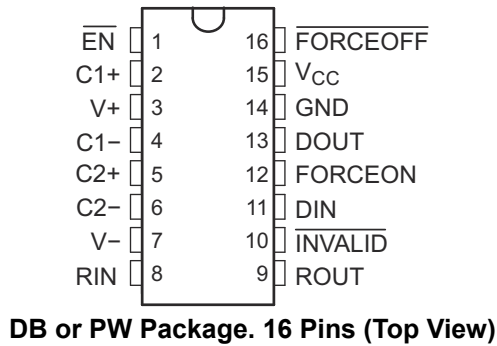
6.1 Absolute Maximum Ratings

over operating free-air temperature range (unless otherwise noted) See (1)

		MIN	MAX	UNIT	
V _{CC}	Supply voltage range ⁽²⁾	- 0.3	6	V	
V+	Positive output supply voltage range ⁽²⁾	- 0.3	7	V	
V-	Negative output supply voltage range ⁽²⁾	0.3	- 7	V	
V+ - V-	Supply voltage difference ⁽²⁾		13	V	
V _I	Input voltage range	Driver (FORCEOFF, FORCEON, EN)	- 0.3	6	V
		Receiver	- 25	25	
V _O	Output voltage range	Driver	- 13.2	13.2	V
		Receiver (INVALID)	- 0.3	V _{CC} + 0.3	
T _J	Operating virtual junction temperature		150	°C	
T _{stg}	Storage temperature range	- 65	150	°C	

- (1) Stresses beyond those listed under "absolute maximum ratings" may cause permanent damage to the device. These are stress ratings only, and functional operation of the device at these or any other conditions beyond those indicated under "recommended operating conditions" is not implied. Exposure to absolute-maximum-rated conditions for extended periods may affect device reliability.
- (2) All voltages are with respect to network GND.

6.2 ESD Ratings

		VALUE	UNIT	
V _(ESD)	Electrostatic discharge	Human-body model (HBM), per ANSI/ESDA/JEDEC JS-001 ⁽¹⁾	±3000	V
		Charged-device model (CDM), per JEDEC specification JESD22-C101 ⁽²⁾	±1500	

- (1) JEDEC document JEP155 states that 500-V HBM allows safe manufacturing with a standard ESD control process.
- (2) JEDEC document JEP157 states that 250-V CDM allows safe manufacturing with a standard ESD control process.

6.3 ESD Ratings, IEC Specifications

PIN NAME	TEST CONDITIONS	TYP	UNIT
RIN, DOUT	HBM	±15	kV
	IEC 61000-4-2 Contact Discharge ⁽¹⁾	±8	
	IEC 61000-4-2 Air-Gap Discharge ⁽¹⁾	±15	

- (1) For the RGT and PW package only, a minimum of 1-μF capacitor is required between VCC and GND to meet the specified IEC-ESD level.

6.4 Recommended Operating Conditions

See 图 9-1 and (1)

			MIN	NOM	MAX	UNIT
Supply voltage		$V_{CC} = 3.3\text{ V}$	3	3.3	3.6	V
		$V_{CC} = 5\text{ V}$	4.5	5	5.5	
V_{IH}	Driver and control high-level input voltage	DIN, FORCEOFF, FORCEON, EN	$V_{CC} = 3.3\text{ V}$	2		V
			$V_{CC} = 5\text{ V}$	2.4		
V_{IL}	Driver and control low-level input voltage	DIN, FORCEOFF, FORCEON, EN			0.8	V
V_I	Driver and control input voltage	DIN, FORCEOFF, FORCEON	0	5.5		V
V_I	Receiver input voltage		-25	25		V
T_A	Operating free-air temperature	TRSF3221EI	-40	85		°C
		TRSF3221EC	0	70		

(1) Test conditions are $C1 - C4 = 0.1\ \mu\text{F}$ at $V_{CC} = 3.3\text{ V} \pm 0.3\text{ V}$; $C1 = 0.047\ \mu\text{F}$, $C2 - C4 = 0.33\ \mu\text{F}$ at $V_{CC} = 5\text{ V} \pm 0.5\text{ V}$.

6.5 Thermal Resistance Characteristics

THERMAL METRIC ⁽¹⁾		TRSF3221E			UNIT
		DB (SSOP)	PW (TSSOP)	RGT (VQFN)	
		16 Pins	16 Pins	16 Pins	
$R_{\theta JA}$	Junction-to-ambient thermal resistance	82	110.9	58.8	°C/W
$R_{\theta JC(top)}$	Junction-to-case (top) thermal resistance	45.7	41.7	55.8	°C/W
$R_{\theta JB}$	Junction-to-board thermal resistance	44.4	57.2	23.8	°C/W
ψ_{JT}	Junction-to-top characterization parameter	11.0	4.2	1.7	°C/W
ψ_{JB}	Junction-to-board characterization parameter	43.8	56.6	23.7	°C/W
$R_{\theta JC(bot)}$	Junction-to-case (bottom) thermal resistance	N/A	N/A	9	°C/W

(1) For more information about traditional and new thermal metrics, see the [Semiconductor and IC package thermal metrics](#) application report.

6.6 Electrical Characteristics

over recommended ranges of supply voltage and operating free-air temperature (unless otherwise noted)

(see 图 9-1)

PARAMETER		TEST CONDITIONS ⁽¹⁾	MIN	TYP ⁽²⁾	MAX	UNIT
I_I	Input leakage current	FORCEOFF, FORCEON, EN		±0.01	±1	μA
I_{CC}	Supply current ($T_A = 25^\circ\text{C}$)	Auto-powerdown disabled	No load, FORCEOFF and FORCEON at V_{CC}	0.3	1	mA
		Powered off	No load, FORCEOFF at GND	1	10	
		Auto-powerdown enabled	No load, FORCEOFF at V_{CC} , FORCEON at GND, All RIN are open or grounded	1	10	μA

(1) Test conditions are $C1 - C4 = 0.1\ \mu\text{F}$ at $V_{CC} = 3.3\text{ V} \pm 0.3\text{ V}$; $C1 = 0.047\ \mu\text{F}$, $C2 - C4 = 0.33\ \mu\text{F}$ at $V_{CC} = 5\text{ V} \pm 0.5\text{ V}$.

(2) All typical values are at $V_{CC} = 3.3\text{ V}$ or $V_{CC} = 5\text{ V}$, and $T_A = 25^\circ\text{C}$.

6.7 Electrical Characteristics, Driver

over recommended ranges of supply voltage and operating free-air temperature (unless otherwise noted)

(see [Figure 9-1](#))

PARAMETER	TEST CONDITIONS ⁽¹⁾	MIN	TYP ⁽²⁾	MAX	UNIT	
V _{OH}	High-level output voltage	DOUT at R _L = 3 kΩ to GND, DIN = GND		5	5.4	V
V _{OL}	Low-level output voltage	DOUT at R _L = 3 kΩ to GND, DIN = V _{CC}		-5	-5.4	V
I _{IH}	High-level input current	V _I = V _{CC}		±0.01	±1	μA
I _{IL}	Low-level input current	V _I at GND		±0.01	±1	μA
I _{OS}	Short-circuit output current ⁽³⁾	V _{CC} = 3.6 V, V _O = 0 V		±35	±60	mA
		V _{CC} = 5.5 V, V _O = 0 V		±35	±90	
r _o	Output resistance	V _{CC} , V ₊ , and V ₋ = 0 V, V _O = ±2 V		300	10M	Ω
I _{off}	Output leakage current	FORCEOFF = GND, V _O = ±12 V, V _{CC} = 3 V to 3.6 V				±25
		V _O = ±10 V, V _{CC} = 4.5 V to 5.5 V				±25

(1) Test conditions are C₁ - C₄ = 0.1 μF at V_{CC} = 3.3 V ± 0.3 V; C₁ = 0.047 μF, C₂ - C₄ = 0.33 μF at V_{CC} = 5 V ± 0.5 V.

(2) All typical values are at V_{CC} = 3.3 V or V_{CC} = 5 V, and T_A = 25°C.

(3) Short-circuit durations must be controlled to prevent exceeding the device absolute power dissipation ratings, and not more than one output can be shorted at a time.

6.8 Switching Characteristics, Driver

over recommended ranges of supply voltage and operating free-air temperature (unless otherwise noted)

(see [Figure 9-1](#))

PARAMETER	TEST CONDITIONS ⁽¹⁾	MIN	TYP ⁽²⁾	MAX	UNIT		
Maximum data rate (see Figure 7-1)	R _L = 3 kΩ	C _L = 1000 pF		250	kbit/s		
		C _L = 250 pF, V _{CC} = 3 V to 4.5 V		1000			
		C _L = 1000 pF, V _{CC} = 4.5 V to 5.5 V		1000			
t _{sk(p)}	Pulse skew ⁽³⁾	C _L = 250 pF	R _L = 3 kΩ Figure 7-2	RGT Package	25	ns	
		C _L = 150 pF to 2500 pF,	R _L = 3 kΩ to 7 kΩ, See Figure 7-2	DB or PW package	100		
SR(tr)	Slew rate, transition region (see Figure 7-1)	V _{CC} = 3.3 V,	R _L = 3 kΩ to 7 kΩ,	C _L = 150 pF to 1000 pF	18	150	V/μs

(1) Test conditions are C₁ - C₄ = 0.1 μF at V_{CC} = 3.3 V ± 0.3 V; C₁ = 0.047 μF, C₂ - C₄ = 0.33 μF at V_{CC} = 5 V ± 0.5 V.

(2) All typical values are at V_{CC} = 3.3 V or V_{CC} = 5 V, and T_A = 25°C.

(3) Pulse skew is defined as |t_{PLH} - t_{PHL}| of each channel of the same device.

6.9 Electrical Characteristics, Receiver

over recommended ranges of supply voltage and operating free-air temperature (unless otherwise noted)
(see [图 9-1](#))

PARAMETER		TEST CONDITIONS ⁽¹⁾	MIN	TYP ⁽²⁾	MAX	UNIT
V _{OH}	High-level output voltage	I _{OH} = - 1 mA	V _{CC} - 0.6 V	V _{CC} - 0.1 V		V
V _{OL}	Low-level output voltage	I _{OL} = 1.6 mA			0.4	V
V _{IT+}	Positive-going input threshold voltage	V _{CC} = 3.3 V		1.6	2.4	V
		V _{CC} = 5 V		1.9	2.4	
V _{IT-}	Negative-going input threshold voltage	V _{CC} = 3.3 V	0.6	1.1		V
		V _{CC} = 5 V	0.8	1.4		
V _{hys}	Input hysteresis (V _{IT+} - V _{IT-})			0.5		V
I _{off}	Output leakage current	FORCEOFF = 0 V		±0.05	±10	μ A
r _i	Input resistance	V _I = ±3 V to ±25 V	3	5	7	kΩ

- (1) Test conditions are C1 - C4 = 0.1 μ F at V_{CC} = 3.3 V ± 0.3 V; C1 = 0.047 μ F, C2 - C4 = 0.33 μ F at V_{CC} = 5 V ± 0.5 V.
(2) All typical values are at V_{CC} = 3.3 V or V_{CC} = 5 V, and T_A = 25°C.

6.10 Switching Characteristics, Receiver

over recommended ranges of supply voltage and operating free-air temperature (unless otherwise noted)
(see [图 9-1](#))

PARAMETER		TEST CONDITIONS ⁽¹⁾	TYP ⁽²⁾	UNIT	
t _{PLH}	Propagation delay time, low- to high-level output	C _L = 150 pF, See 图 7-3	RGT package	100	ns
			DB or PW package	150	
t _{PHL}	Propagation delay time, high- to low-level output	C _L = 150 pF, See 图 7-3	RGT package	125	ns
			DB or PW package	150	
t _{en}	Output enable time	C _L = 150 pF, R _L = 3 kΩ, See 图 7-4	200	ns	
t _{dis}	Output disable time	C _L = 150 pF, R _L = 3 kΩ, See 图 7-4	200	ns	
t _{sk(p)}	Pulse skew ⁽³⁾	See 图 7-3	RGT package	25	ns
			DB or PW package	50	

- (1) Test conditions are C1 - C4 = 0.1 μ F at V_{CC} = 3.3 V ± 0.3 V; C1 = 0.047 μ F, C2 - C4 = 0.33 μ F at V_{CC} = 5 V ± 0.5 V.
(2) All typical values are at V_{CC} = 3.3 V or V_{CC} = 5 V, and T_A = 25°C.
(3) Pulse skew is defined as |t_{PLH} - t_{PHL}| of each channel of the same device.

6.11 Electrical Characteristics, Auto-Powerdown

over recommended ranges of supply voltage and operating free-air temperature (unless otherwise noted)
(see 图 7-5)

PARAMETER		TEST CONDITIONS		MIN	MAX	UNIT
V_{T+} (valid)	Receiver input threshold for $\overline{\text{INVALID}}$ high-level output voltage	FORCEON = GND,	FORCEOFF = V_{CC}		2.7	V
V_{T-} (valid)	Receiver input threshold for $\overline{\text{INVALID}}$ high-level output voltage	FORCEON = GND,	FORCEOFF = V_{CC}	- 2.7		V
V_{T} (invalid)	Receiver input threshold for $\overline{\text{INVALID}}$ low-level output voltage	FORCEON = GND,	FORCEOFF = V_{CC}	- 0.3	0.3	V
V_{OH}	$\overline{\text{INVALID}}$ high-level output voltage	$I_{OH} = - 1 \text{ mA}$, FORCEON = GND,	FORCEOFF = V_{CC}	$V_{CC} - 0.6$		V
V_{OL}	$\overline{\text{INVALID}}$ low-level output voltage	$I_{OL} = 1.6 \text{ mA}$, FORCEON = GND,	FORCEOFF = V_{CC}		0.4	V

6.12 Switching Characteristics, Auto-Powerdown

over recommended ranges of supply voltage and operating free-air temperature (unless otherwise noted)
(see 图 7-5)

PARAMETER		TYP ⁽¹⁾	UNIT
t_{valid}	Propagation delay time, low- to high-level output	1	μs
t_{invalid}	Propagation delay time, high- to low-level output	30	μs
t_{en}	Supply enable time	100	μs

(1) All typical values are at $V_{CC} = 3.3 \text{ V}$ or $V_{CC} = 5 \text{ V}$, and $T_A = 25^\circ\text{C}$.

6.13 Typical Characteristics

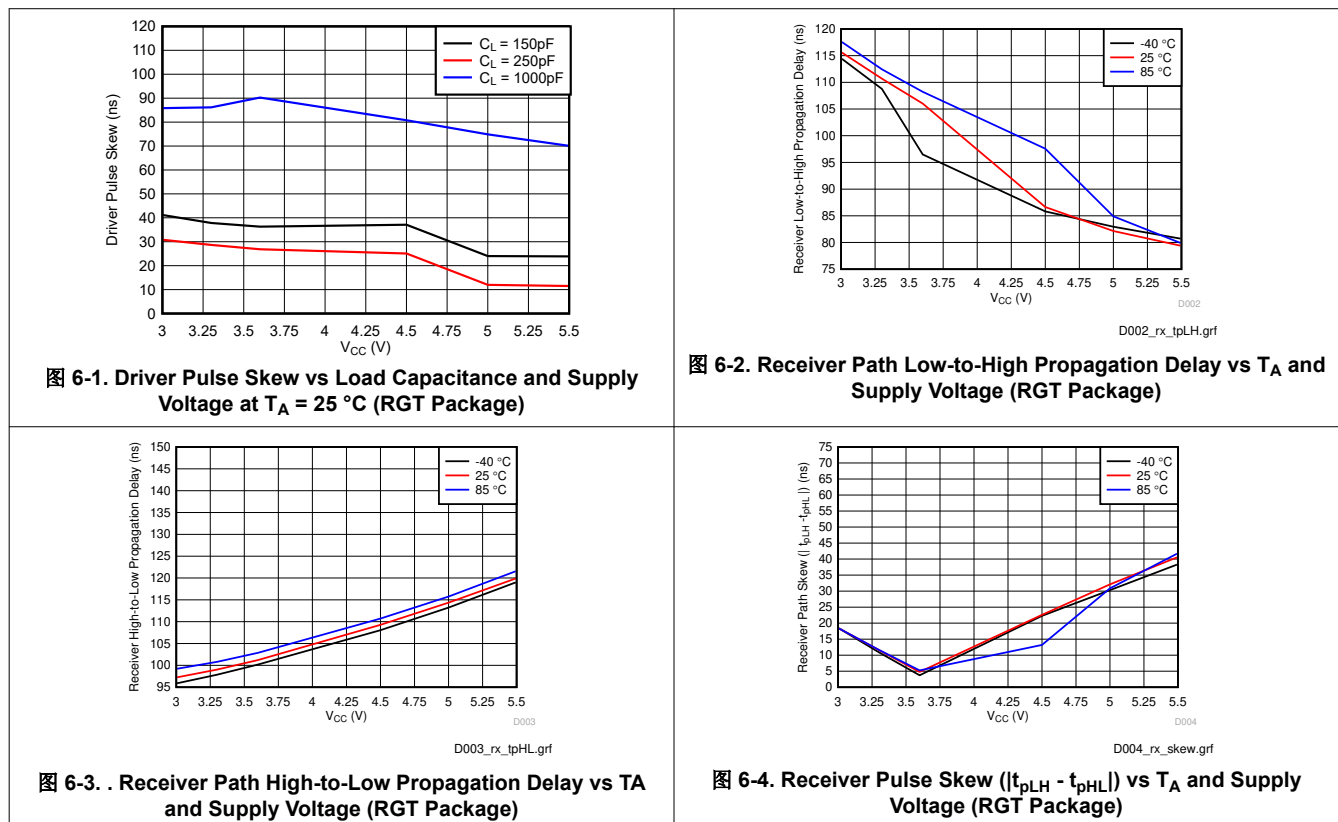

7 Parameter Measurement Information

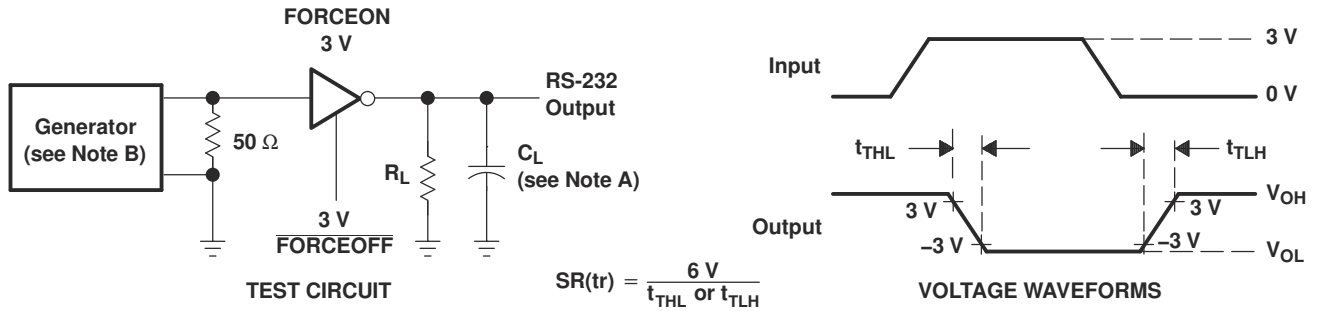

- NOTES: A. C_L includes probe and jig capacitance.
B. The pulse generator has the following characteristics: PRR = 250 kbit/s, $Z_O = 50\ \Omega$, 50% duty cycle, $t_r \leq 10\text{ ns}$, $t_f \leq 10\text{ ns}$.

图 7-1. Driver Slew Rate

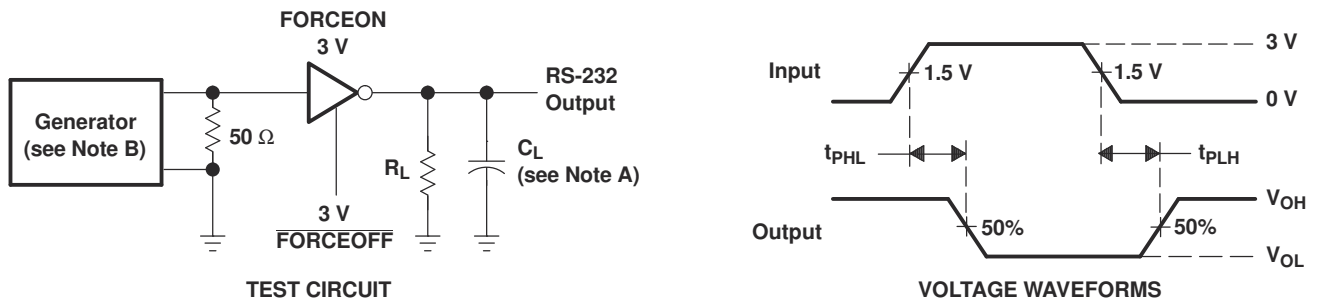

- NOTES: A. C_L includes probe and jig capacitance.
B. The pulse generator has the following characteristics: PRR = 250 kbit/s, $Z_O = 50\ \Omega$, 50% duty cycle, $t_r \leq 10\text{ ns}$, $t_f \leq 10\text{ ns}$.

图 7-2. Driver Pulse Skew

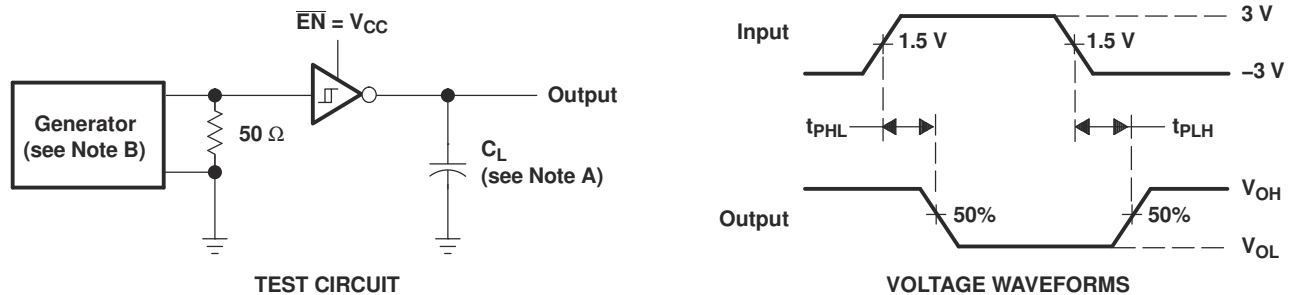

- NOTES: A. C_L includes probe and jig capacitance.
B. The pulse generator has the following characteristics: $Z_O = 50\ \Omega$, 50% duty cycle, $t_r \leq 10\text{ ns}$, $t_f \leq 10\text{ ns}$.

图 7-3. Receiver Propagation Delay Times

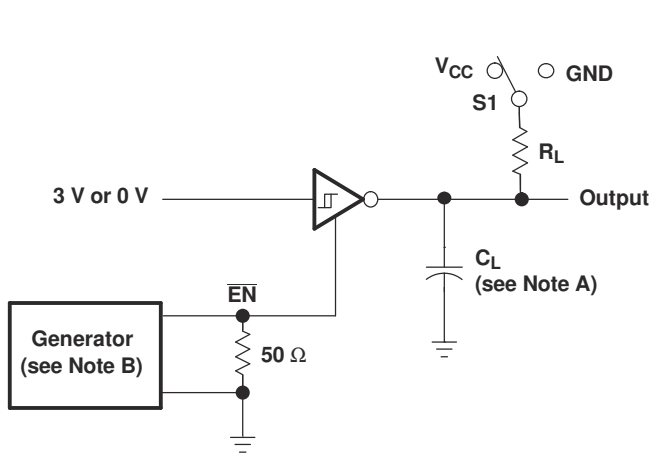

TEST CIRCUIT

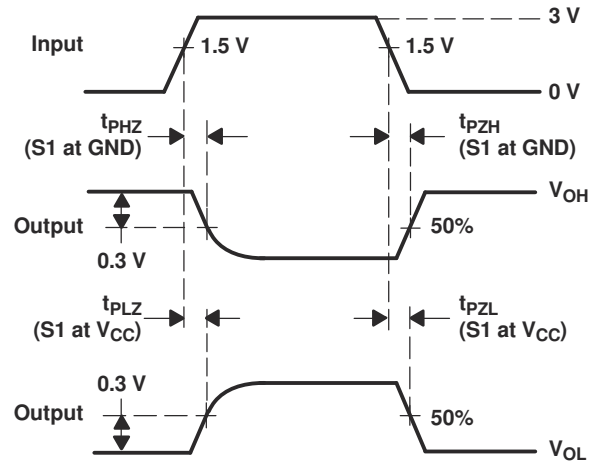

VOLTAGE WAVEFORMS

- NOTES:
- A. C_L includes probe and jig capacitance.
 - B. The pulse generator has the following characteristics: $Z_O = 50 \Omega$, 50% duty cycle, $t_r \leq 10 \text{ ns}$, $t_f \leq 10 \text{ ns}$.
 - C. t_{PLZ} and t_{PHZ} are the same as t_{dis} .
 - D. t_{PZL} and t_{PZH} are the same as t_{en} .

图 7-4. Receiver Enable and Disable Times

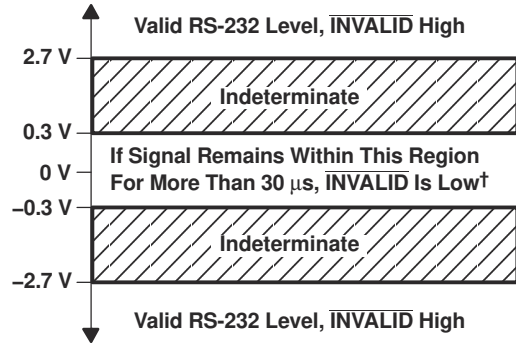
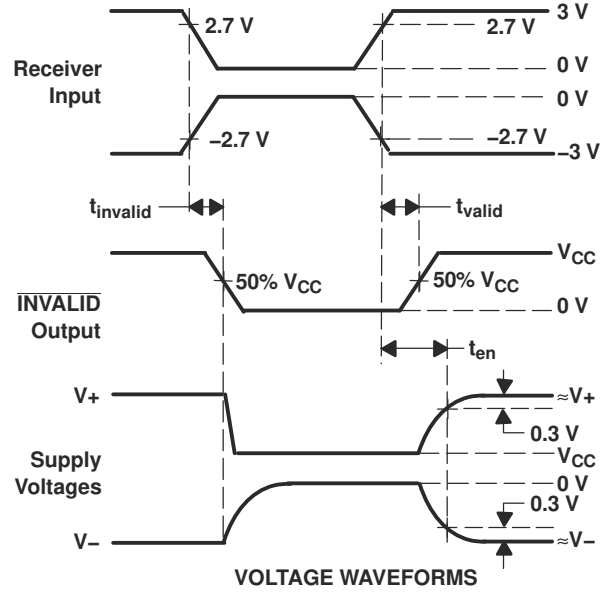
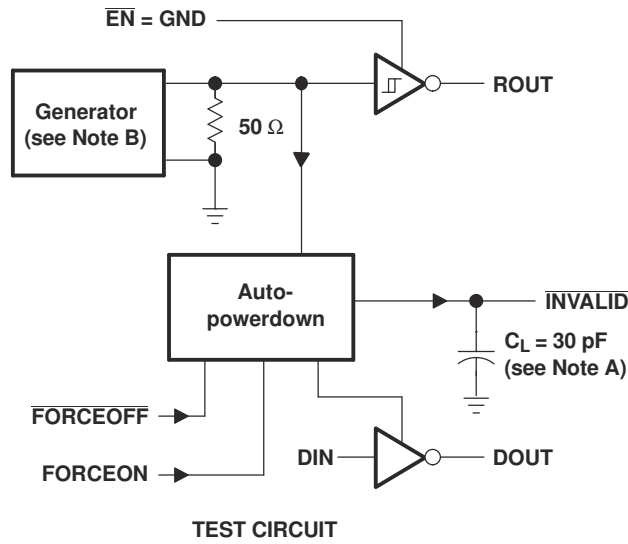

† Auto-powerdown disables drivers and reduces supply current to 1 μ A.

- NOTES: A. C_L includes probe and jig capacitance.
B. The pulse generator has the following characteristics: PRR = 5 kbit/s, $Z_O = 50 \Omega$, 50% duty cycle, $t_r \leq 10$ ns, $t_f \leq 10$ ns.

图 7-5. INVALID Propagation Delay Times and Driver Enabling Time

8 Detailed Description

8.1 Overview

The TRSF3221E consists of one line driver, one line receiver, and a dual charge-pump circuit with ± 15 -kV IEC ESD protection pin to pin (serial-port connection pins, including GND). The TRSF3221E provides the electrical interface between an asynchronous communication controller and the serial-port connector. The charge pump and four small external capacitors allow operation from a single 3-V to 5.5-V supply. The TRSF3221E operates at data signaling rates up to 1 Mbit/s and a driver output slew rate of 24 V/ μ s to 150 V/ μ s.

Flexible control options for power management are available when the serial port is inactive. The auto-powerdown feature functions when FORCEON is low and FORCEOFF is high. During this mode of operation, if the TRSF3221E does not sense a valid RS-232 signal on the receiver input, the driver output is disabled. If FORCEOFF is set low and the enable (EN) input is high, both the driver and receiver are shut off, and the supply current is reduced to 1 μ A. Disconnecting the serial port or turning off the peripheral drivers causes the auto-powerdown condition to occur. Auto-powerdown can be disabled when FORCEON and FORCEOFF are high. With auto-powerdown enabled, the device is activated automatically when a valid signal is applied to the receiver input. The INVALID output notifies the user if an RS-232 signal is present at the receiver input. INVALID is high (valid data) if the receiver input voltage is greater than 2.7 V or less than -2.7 V, or has been between -0.3 V and 0.3 V for less than 30 μ s. INVALID is low (invalid data) if the receiver input voltage is between -0.3 V and 0.3 V for more than 30 μ s.

Outputs are protected against shorts to ground.

8.2 Functional Block Diagram



图 8-1. Logic Diagram (Positive Logic)

8.3 Feature Description

The power block increases, inverts, and regulates voltage at V+ and V- pins using a charge pump that requires four external capacitors. Auto-power-down feature for driver is controlled by FORCEON and FORCEOFF inputs. Receiver is controlled by EN input. When MAX3221E is unpowered, it can be safely connected to an active remote RS-232 device.

The driver interfaces the standard logic level to RS232 voltage levels. The DIN input must be valid high or low.

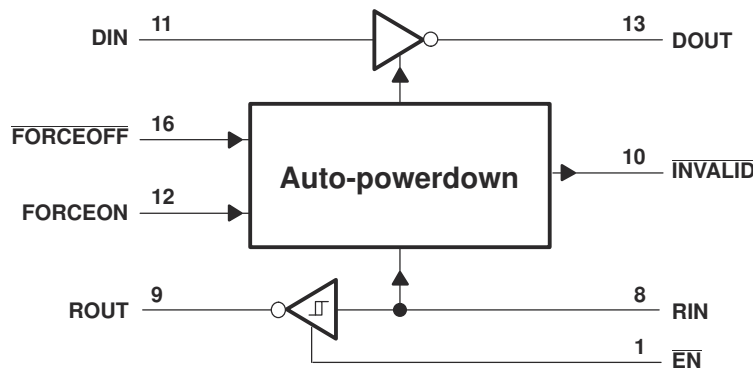
The receiver interfaces RS-232 levels to standard logic levels. An open input results in a high output on ROUT. RIN input includes an internal standard RS-232 load. A logic high input on the EN pin shuts down the receiver output.

8.4 Device Functional Modes

Functional Tables, Each Driver

INPUTS ⁽¹⁾				OUTPUT DOUT	DRIVER STATUS
DIN	FORCEON	FORCEOFF	VALID RIN RS-232 LEVEL		
X	X	L	X	Z	Powered off
L	H	H	X	H	Normal operation with auto-powerdown disabled
H	H	H	X	L	
L	L	H	Yes	H	Normal operation with auto-powerdown enabled
H	L	H	Yes	L	
L	L	H	No	Z	Powered off by auto-powerdown feature
H	L	H	No	Z	

(1) H = high level, L = low level, X = irrelevant, Z = high impedance

Each Receiver

INPUTS ⁽¹⁾			OUTPUT ROUT
RIN	EN	VALID RIN RS-232 LEVEL	
L	L	X	H
H	L	X	L
X	H	X	Z
Open	L	No	H

(1) H = high level, L = low level, X = irrelevant, Z = high impedance (off), Open = disconnected input or connected driver off

9 Application and Implementation

Note

以下应用部分中的信息不属于 TI 器件规格的范围，TI 不担保其准确性和完整性。TI 的客户应负责确定器件是否适用于其应用。客户应验证并测试其设计，以确保系统功能。

9.1 Application Information

The TRSF3221E line driver and receiver is a specialized device for 3-V to 5.5-V RS-232 communication applications. This application is a generic implementation of this device with all required external components. For proper operation, add capacitors as shown in 表 9-1.

9.1.1 Typical Application

ROUT and DIN connect to UART or general purpose logic lines. FORCEON and FORCEOFF may be connected to general purpose logic lines or tied to ground or VCC. INVALID may be connected to a general purpose logic line or left unconnected. RIN and DOUT lines connect to a RS-232 connector or cable. DIN, FORCEON, and FORCEOFF inputs must not be left unconnected.

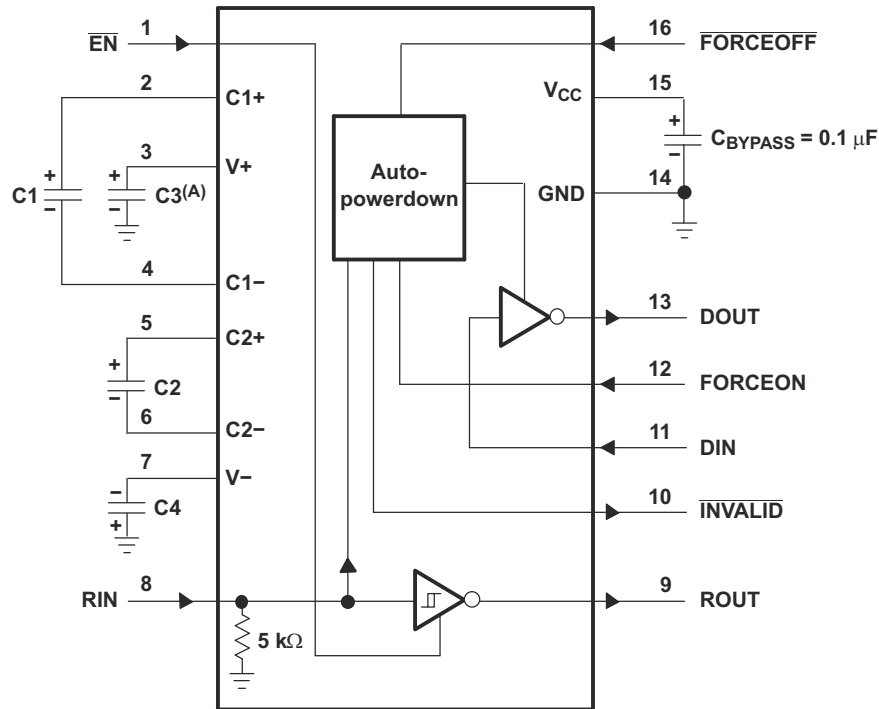

- A. C3 can be connected to V_{CC} or GND.
- B. Resistor values shown are nominal.
- C. Nonpolarized ceramic capacitors are acceptable. If polarized tantalum or electrolytic capacitors are used, they must be connected as shown.

图 9-1. Typical Operating Circuit and Capacitor Values

表 9-1. V_{CC} vs Capacitor Values

V _{CC}	C1	C2, C3, C4
3.3 V ± 0.3 V	0.1 μF	0.1 μF
5 V ± 0.5 V	0.047 μF	0.33 μF
3 V to 5.5 V	0.1 μF	0.47 μF

9.1.1.1 Design Requirements

- Recommended VCC is 3.3 V or 5 V - 3 V to 5.5 V is also possible
- Maximum recommended bit rate is 1 Mbps
- Use capacitors as shown in 图 9-1 and 表 9-1

9.1.1.2 Detailed Design Procedure

For proper operation:

- DIN, FORCEOFF and FORCEON inputs must be connected to valid low or high logic levels
- Select capacitor values based on VCC level for best performance

ROUT and DIN connect to UART or general purpose logic lines. FORCEON and FORCEOFF may be connected general purpose logic lines or tied to ground or VCC. INVALID may be connected to a general purpose logic line or left unconnected. RIN and DOUT lines connect to a RS232 connector or cable. DIN, FORCEON, and FORCEOFF inputs must not be left unconnected.

9.1.2 Application Performance Plot



图 9-2. 1 Mbps Driver to Receiver Loopback Timing Waveform, VCC = 3.3 V

10 Power Supply Recommendations

VCC must be between 3 V and 5.5 V. Charge pump capacitors must be chosen using [VCC vs Capacitor Values](#).

11 Layout

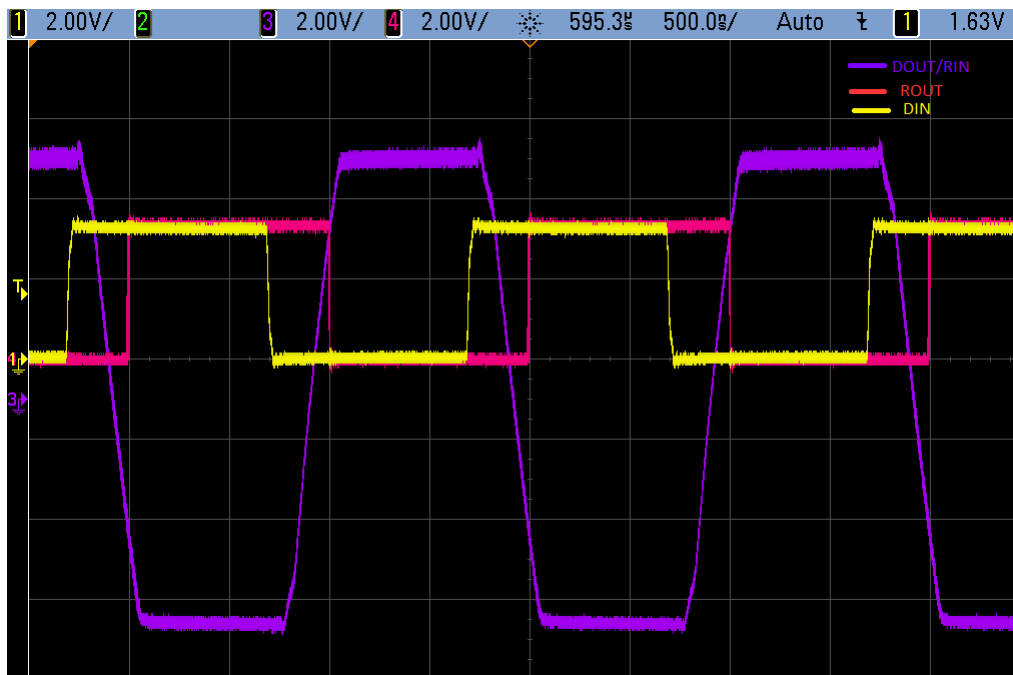
11.1 Layout Guidelines

Keep the external capacitor traces short. This is more important on C1 and C2 nodes, which have the fastest rise and fall times.

11.2 Layout Example



图 11-1. Layout Diagram

12 Device and Documentation Support

12.1 接收文档更新通知

要接收文档更新通知，请导航至 ti.com 上的器件产品文件夹。点击 [订阅更新](#) 进行注册，即可每周接收产品信息更改摘要。有关更改的详细信息，请查看任何已修订文档中包含的修订历史记录。

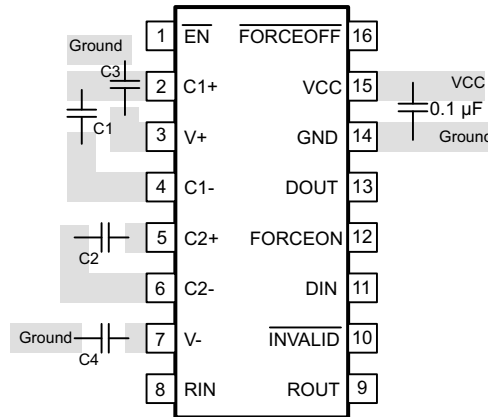
12.2 支持资源

TI E2E™ 支持论坛是工程师的重要参考资料，可直接从专家获得快速、经过验证的解答和设计帮助。搜索现有解答或提出自己的问题可获得所需的快速设计帮助。

链接的内容由各个贡献者“按原样”提供。这些内容并不构成 TI 技术规范，并且不一定反映 TI 的观点；请参阅 TI 的《[使用条款](#)》。

12.3 Trademarks

TI E2E™ is a trademark of Texas Instruments.

所有商标均为其各自所有者的财产。

12.4 Electrostatic Discharge Caution



This integrated circuit can be damaged by ESD. Texas Instruments recommends that all integrated circuits be handled with appropriate precautions. Failure to observe proper handling and installation procedures can cause damage.

ESD damage can range from subtle performance degradation to complete device failure. Precision integrated circuits may be more susceptible to damage because very small parametric changes could cause the device not to meet its published specifications.

12.5 术语表

TI 术语表 本术语表列出并解释了术语、首字母缩略词和定义。

13 Mechanical, Packaging, and Orderable Information

The following pages include mechanical, packaging, and orderable information. This information is the most current data available for the designated devices. This data is subject to change without notice and revision of this document. For browser-based versions of this data sheet, refer to the left-hand navigation.

重要声明和免责声明

TI 提供技术和可靠性数据 (包括数据表)、设计资源 (包括参考设计)、应用或其他设计建议、网络工具、安全信息和其他资源, 不保证没有瑕疵且不做任何明示或暗示的担保, 包括但不限于对适销性、某特定用途方面的适用性或不侵犯任何第三方知识产权的暗示担保。

这些资源可供使用 TI 产品进行设计的熟练开发人员使用。您将自行承担以下全部责任: (1) 针对您的应用选择合适的 TI 产品, (2) 设计、验证并测试您的应用, (3) 确保您的应用满足相应标准以及任何其他安全、安保或其他要求。这些资源如有变更, 恕不另行通知。TI 授权您仅可将这些资源用于研发本资源所述的 TI 产品的应用。严禁对这些资源进行其他复制或展示。您无权使用任何其他 TI 知识产权或任何第三方知识产权。您应全额赔偿因在这些资源的使用中对 TI 及其代表造成的任何索赔、损害、成本、损失和债务, TI 对此概不负责。

TI 提供的产品受 TI 的销售条款 (<https://www.ti.com/legal/termsofsale.html>) 或 [ti.com](https://www.ti.com) 上其他适用条款/TI 产品随附的其他适用条款的约束。TI 提供这些资源并不会扩展或以其他方式更改 TI 针对 TI 产品发布的适用的担保或担保免责声明。

邮寄地址: Texas Instruments, Post Office Box 655303, Dallas, Texas 75265
Copyright © 2021, 德州仪器 (TI) 公司

PACKAGING INFORMATION

Orderable Device	Status (1)	Package Type	Package Drawing	Pins	Package Qty	Eco Plan (2)	Lead finish/ Ball material (6)	MSL Peak Temp (3)	Op Temp (°C)	Device Marking (4/5)	Samples
TRSF3221ECDB	ACTIVE	SSOP	DB	16	80	RoHS & Green	NIPDAU	Level-1-260C-UNLIM	0 to 70	RT21EC	Samples
TRSF3221ECDBG4	ACTIVE	SSOP	DB	16	80	RoHS & Green	NIPDAU	Level-1-260C-UNLIM	0 to 70	RT21EC	Samples
TRSF3221ECDBR	ACTIVE	SSOP	DB	16	2000	RoHS & Green	NIPDAU	Level-1-260C-UNLIM	0 to 70	RT21EC	Samples
TRSF3221ECDBRG4	ACTIVE	SSOP	DB	16	2000	RoHS & Green	NIPDAU	Level-1-260C-UNLIM	0 to 70	RT21EC	Samples
TRSF3221ECPW	NRND	TSSOP	PW	16	90	RoHS & Green	NIPDAU	Level-1-260C-UNLIM	0 to 70	RT21EC	
TRSF3221ECPWR	ACTIVE	TSSOP	PW	16	2000	RoHS & Green	NIPDAU	Level-1-260C-UNLIM	0 to 70	RT21EC	Samples
TRSF3221EIDBR	ACTIVE	SSOP	DB	16	2000	RoHS & Green	NIPDAU	Level-1-260C-UNLIM	-40 to 85	RT21EI	Samples
TRSF3221EIPW	NRND	TSSOP	PW	16	90	RoHS & Green	NIPDAU	Level-1-260C-UNLIM	-40 to 85	RT21EI	
TRSF3221EIPWR	ACTIVE	TSSOP	PW	16	2000	RoHS & Green	NIPDAU	Level-1-260C-UNLIM	-40 to 85	RT21EI	Samples
TRSF3221EIPWRG4	ACTIVE	TSSOP	PW	16	2000	RoHS & Green	NIPDAU	Level-1-260C-UNLIM	-40 to 85	RT21EI	Samples
TRSF3221EIRGTR	ACTIVE	VQFN	RGT	16	3000	RoHS & Green	NIPDAU	Level-2-260C-1 YEAR	-40 to 85	F3221	Samples

(1) The marketing status values are defined as follows:

ACTIVE: Product device recommended for new designs.

LIFEBUY: TI has announced that the device will be discontinued, and a lifetime-buy period is in effect.

NRND: Not recommended for new designs. Device is in production to support existing customers, but TI does not recommend using this part in a new design.

PREVIEW: Device has been announced but is not in production. Samples may or may not be available.

OBSELETE: TI has discontinued the production of the device.

(2) **RoHS:** TI defines "RoHS" to mean semiconductor products that are compliant with the current EU RoHS requirements for all 10 RoHS substances, including the requirement that RoHS substance do not exceed 0.1% by weight in homogeneous materials. Where designed to be soldered at high temperatures, "RoHS" products are suitable for use in specified lead-free processes. TI may reference these types of products as "Pb-Free".

RoHS Exempt: TI defines "RoHS Exempt" to mean products that contain lead but are compliant with EU RoHS pursuant to a specific EU RoHS exemption.

Green: TI defines "Green" to mean the content of Chlorine (Cl) and Bromine (Br) based flame retardants meet JS709B low halogen requirements of <=1000ppm threshold. Antimony trioxide based flame retardants must also meet the <=1000ppm threshold requirement.

(3) MSL, Peak Temp. - The Moisture Sensitivity Level rating according to the JEDEC industry standard classifications, and peak solder temperature.

- (4) There may be additional marking, which relates to the logo, the lot trace code information, or the environmental category on the device.
- (5) Multiple Device Markings will be inside parentheses. Only one Device Marking contained in parentheses and separated by a "~" will appear on a device. If a line is indented then it is a continuation of the previous line and the two combined represent the entire Device Marking for that device.
- (6) Lead finish/Ball material - Orderable Devices may have multiple material finish options. Finish options are separated by a vertical ruled line. Lead finish/Ball material values may wrap to two lines if the finish value exceeds the maximum column width.

Important Information and Disclaimer:The information provided on this page represents TI's knowledge and belief as of the date that it is provided. TI bases its knowledge and belief on information provided by third parties, and makes no representation or warranty as to the accuracy of such information. Efforts are underway to better integrate information from third parties. TI has taken and continues to take reasonable steps to provide representative and accurate information but may not have conducted destructive testing or chemical analysis on incoming materials and chemicals. TI and TI suppliers consider certain information to be proprietary, and thus CAS numbers and other limited information may not be available for release.

In no event shall TI's liability arising out of such information exceed the total purchase price of the TI part(s) at issue in this document sold by TI to Customer on an annual basis.

TAPE AND REEL INFORMATION

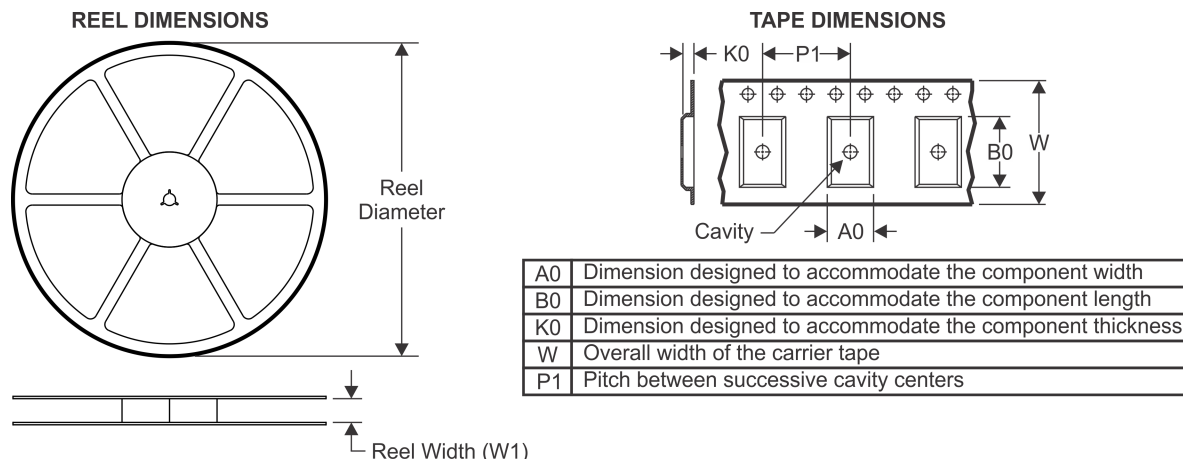

QUADRANT ASSIGNMENTS FOR PIN 1 ORIENTATION IN TAPE



*All dimensions are nominal

Device	Package Type	Package Drawing	Pins	SPQ	Reel Diameter (mm)	Reel Width W1 (mm)	A0 (mm)	B0 (mm)	K0 (mm)	P1 (mm)	W (mm)	Pin1 Quadrant
TRSF3221ECDBR	SSOP	DB	16	2000	330.0	16.4	8.35	6.6	2.4	12.0	16.0	Q1
TRSF3221ECPWR	TSSOP	PW	16	2000	330.0	12.4	6.9	5.6	1.6	8.0	12.0	Q1
TRSF3221ECPWR	TSSOP	PW	16	2000	330.0	12.4	6.9	5.6	1.6	8.0	12.0	Q1
TRSF3221EIDBR	SSOP	DB	16	2000	330.0	16.4	8.35	6.6	2.4	12.0	16.0	Q1
TRSF3221EIPWR	TSSOP	PW	16	2000	330.0	12.4	6.9	5.6	1.6	8.0	12.0	Q1
TRSF3221EIPWR	TSSOP	PW	16	2000	330.0	12.4	6.9	5.6	1.6	8.0	12.0	Q1
TRSF3221EIRGTR	VQFN	RGT	16	3000	330.0	12.4	3.3	3.3	1.1	8.0	12.0	Q2

TAPE AND REEL BOX DIMENSIONS

*All dimensions are nominal

Device	Package Type	Package Drawing	Pins	SPQ	Length (mm)	Width (mm)	Height (mm)
TRSF3221ECDBR	SSOP	DB	16	2000	853.0	449.0	35.0
TRSF3221ECPWR	TSSOP	PW	16	2000	853.0	449.0	35.0
TRSF3221ECPWR	TSSOP	PW	16	2000	853.0	449.0	35.0
TRSF3221EIDBR	SSOP	DB	16	2000	853.0	449.0	35.0
TRSF3221EIPWR	TSSOP	PW	16	2000	853.0	449.0	35.0
TRSF3221EIPWR	TSSOP	PW	16	2000	853.0	449.0	35.0
TRSF3221EIRGTR	VQFN	RGT	16	3000	367.0	367.0	35.0

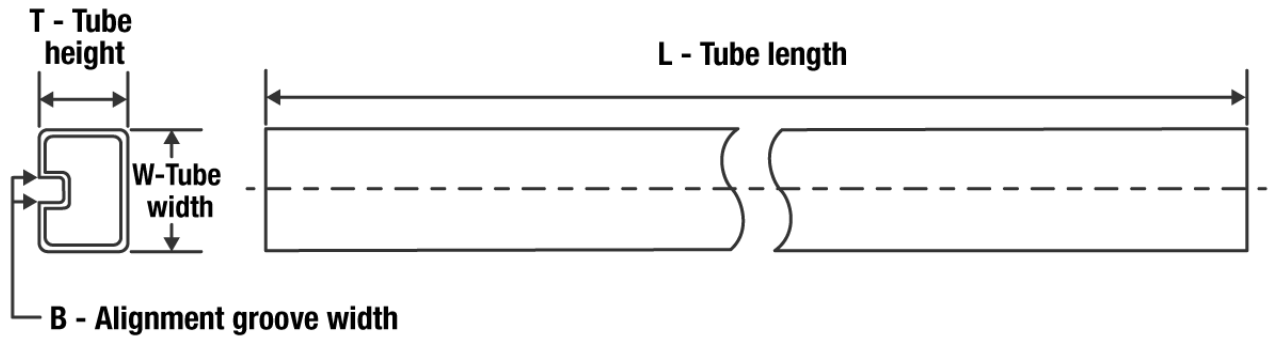
TUBE

*All dimensions are nominal

Device	Package Name	Package Type	Pins	SPQ	L (mm)	W (mm)	T (μm)	B (mm)
TRSF3221ECDB	DB	SSOP	16	80	530	10.5	4000	4.1
TRSF3221ECDBG4	DB	SSOP	16	80	530	10.5	4000	4.1
TRSF3221ECPW	PW	TSSOP	16	90	530	10.2	3600	3.5
TRSF3221EIPW	PW	TSSOP	16	90	530	10.2	3600	3.5

RGT 16

GENERIC PACKAGE VIEW

VQFN - 1 mm max height

PLASTIC QUAD FLATPACK - NO LEAD

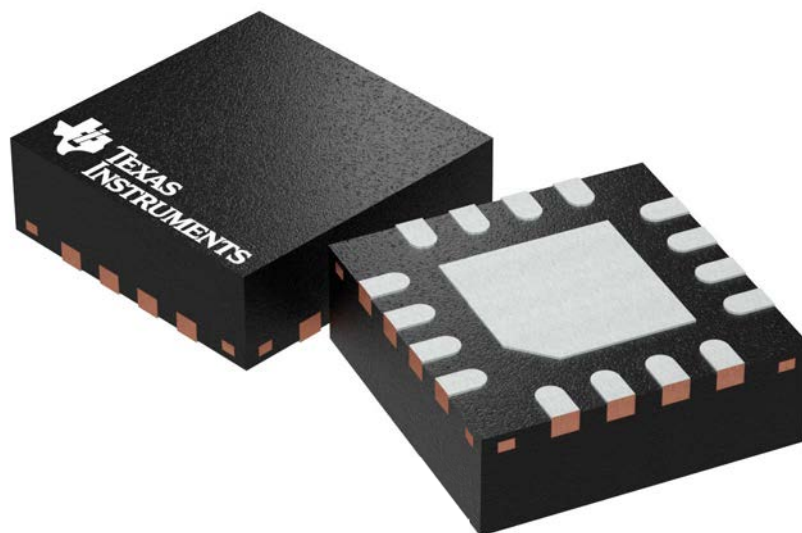

Images above are just a representation of the package family, actual package may vary.
Refer to the product data sheet for package details.

4203495/1

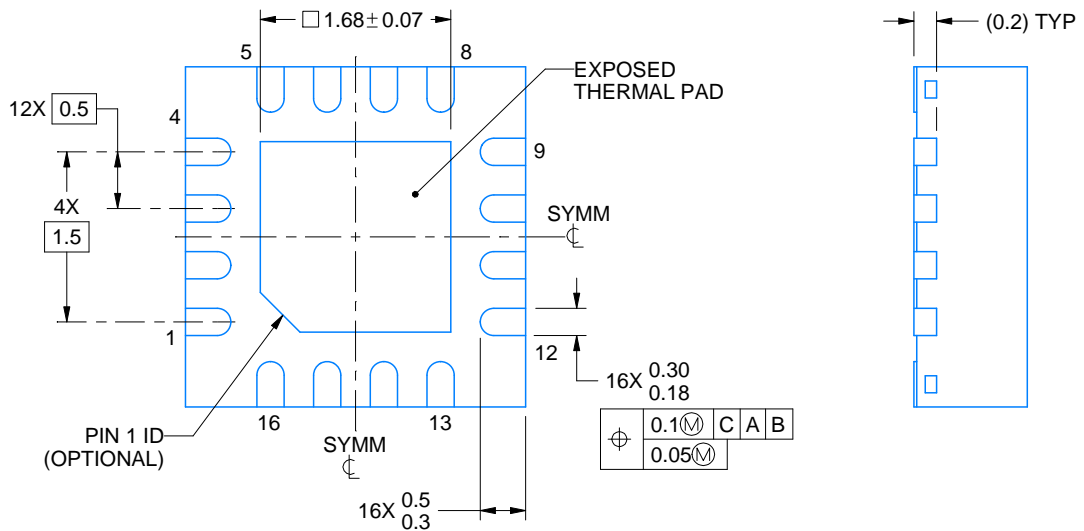
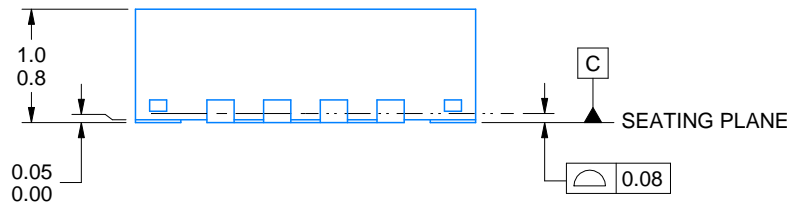
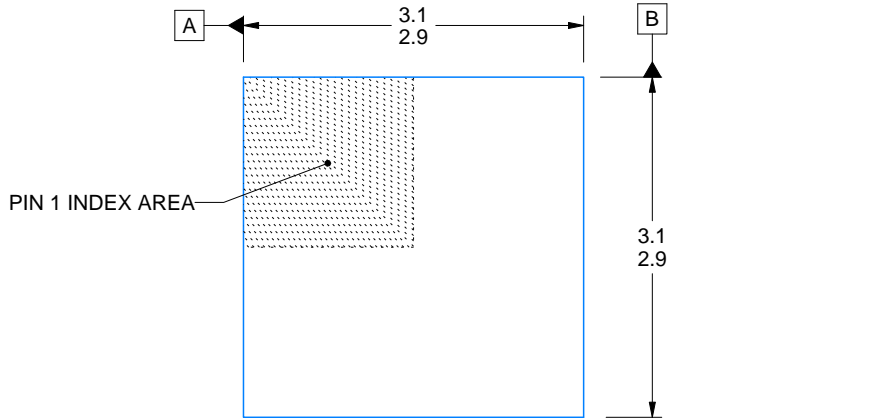
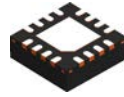

4222419/C 04/2021

NOTES:

1. All linear dimensions are in millimeters. Any dimensions in parenthesis are for reference only. Dimensioning and tolerancing per ASME Y14.5M.
2. This drawing is subject to change without notice.
3. The package thermal pad must be soldered to the printed circuit board for thermal and mechanical performance.

EXAMPLE STENCIL DESIGN

RGT0016C

VQFN - 1 mm max height

PLASTIC QUAD FLATPACK - NO LEAD

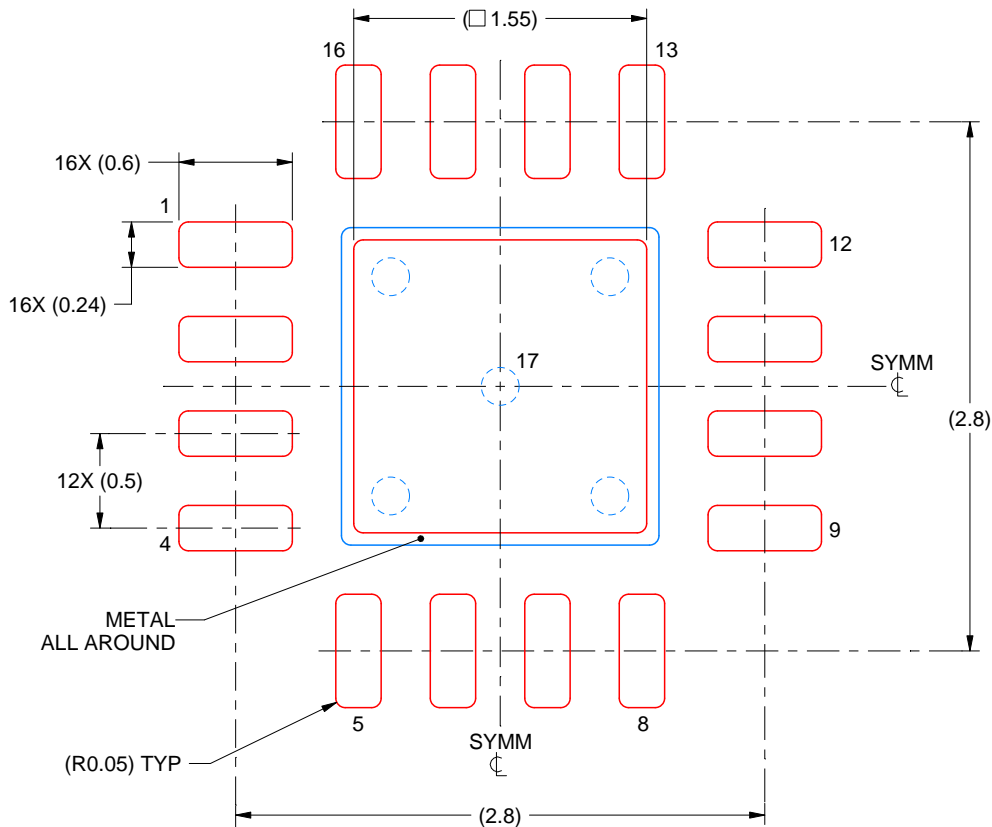

SOLDER PASTE EXAMPLE
BASED ON 0.125 mm THICK STENCIL

EXPOSED PAD 17:
85% PRINTED SOLDER COVERAGE BY AREA UNDER PACKAGE
SCALE:25X

4222419/C 04/2021

NOTES: (continued)

6. Laser cutting apertures with trapezoidal walls and rounded corners may offer better paste release. IPC-7525 may have alternate design recommendations.



4220204/A 02/2017

NOTES:

1. All linear dimensions are in millimeters. Any dimensions in parenthesis are for reference only. Dimensioning and tolerancing per ASME Y14.5M.
2. This drawing is subject to change without notice.
3. This dimension does not include mold flash, protrusions, or gate burrs. Mold flash, protrusions, or gate burrs shall not exceed 0.15 mm per side.
4. This dimension does not include interlead flash. Interlead flash shall not exceed 0.25 mm per side.
5. Reference JEDEC registration MO-153.

EXAMPLE BOARD LAYOUT

PW0016A

TSSOP - 1.2 mm max height

SMALL OUTLINE PACKAGE



LAND PATTERN EXAMPLE
EXPOSED METAL SHOWN
SCALE: 10X



SOLDER MASK DETAILS

4220204/A 02/2017

NOTES: (continued)

- 6. Publication IPC-7351 may have alternate designs.
- 7. Solder mask tolerances between and around signal pads can vary based on board fabrication site.

EXAMPLE STENCIL DESIGN

PW0016A

TSSOP - 1.2 mm max height

SMALL OUTLINE PACKAGE



SOLDER PASTE EXAMPLE
BASED ON 0.125 mm THICK STENCIL
SCALE: 10X

4220204/A 02/2017

NOTES: (continued)

8. Laser cutting apertures with trapezoidal walls and rounded corners may offer better paste release. IPC-7525 may have alternate design recommendations.
9. Board assembly site may have different recommendations for stencil design.

DB (R-PDSO-G**)

PLASTIC SMALL-OUTLINE

28 PINS SHOWN



- NOTES: A. All linear dimensions are in millimeters.
 B. This drawing is subject to change without notice.
 C. Body dimensions do not include mold flash or protrusion not to exceed 0,15.
 D. Falls within JEDEC MO-150

重要声明和免责声明

TI“按原样”提供技术和可靠性数据（包括数据表）、设计资源（包括参考设计）、应用或其他设计建议、网络工具、安全信息和其他资源，不保证没有瑕疵且不做任何明示或暗示的担保，包括但不限于对适销性、某特定用途方面的适用性或不侵犯任何第三方知识产权的暗示担保。

这些资源可供使用 TI 产品进行设计的熟练开发人员使用。您将自行承担以下全部责任：(1) 针对您的应用选择合适的 TI 产品，(2) 设计、验证并测试您的应用，(3) 确保您的应用满足相应标准以及任何其他功能安全、信息安全、监管或其他要求。

这些资源如有变更，恕不另行通知。TI 授权您仅可将这些资源用于研发本资源所述的 TI 产品的应用。严禁对这些资源进行其他复制或展示。您无权使用任何其他 TI 知识产权或任何第三方知识产权。您应全额赔偿因在这些资源的使用中对 TI 及其代表造成的任何索赔、损害、成本、损失和债务，TI 对此概不负责。

TI 提供的产品受 [TI 的销售条款](#) 或 [ti.com](#) 上其他适用条款/TI 产品随附的其他适用条款的约束。TI 提供这些资源并不会扩展或以其他方式更改 TI 针对 TI 产品发布的适用的担保或担保免责声明。

TI 反对并拒绝您可能提出的任何其他或不同的条款。

邮寄地址：Texas Instruments, Post Office Box 655303, Dallas, Texas 75265

Copyright © 2022，德州仪器 (TI) 公司