

FEATURES

- Member of Texas Instruments' Widebus™ Family
- UBT™ Transceiver Combines D-Type Latches and D-Type Flip-Flops for Operation in Transparent, Latched, or Clocked Modes
- TI-OPC™ Circuitry Limits Ringing on Unevenly Loaded Backplanes
- OEC™ Circuitry Improves Signal Integrity and Reduces Electromagnetic Interference
- Bidirectional Interface Between GTLP Signal Levels and LVTTL Logic Levels
- Partitioned as Two 8-Bit Transceivers With Individual Latch Timing and Output Control, but With a Common Clock
- LVTTL Interfaces Are 5-V Tolerant
- High-Drive GTLP Outputs (100 mA)
- LVTTL Outputs (–24 mA/24 mA)
- Variable Edge-Rate Control (ERC) Input Selects GTLP Rise and Fall Times for Optimal Data-Transfer Rate and Signal Integrity in Distributed Loads
- I_{off} , Power-Up 3-State, and BIAS V_{CC} Support Live Insertion
- Bus Hold on A-Port Data Inputs
- Distributed V_{CC} and GND Pins Minimize High-Speed Switching Noise
- Latch-Up Performance Exceeds 100 mA Per JESD 78, Class II
- ESD Protection Exceeds JESD 22
 - 2000-V Human-Body Model (A114-A)
 - 200-V Machine Model (A115-A)
 - 1000-V Charged-Device Model (C101)

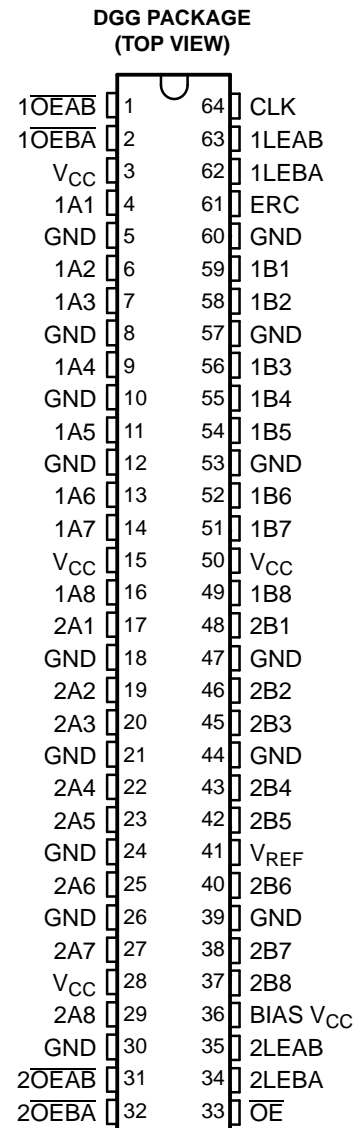

DESCRIPTION

The SN74GTLPH1655 is a high-drive, 16-bit UBT™ transceiver that provides LVTTL-to-GTLP and GTLP-to-LVTTL signal-level translation. It is partitioned as two 8-bit transceivers and allows for transparent, latched, and clocked modes of data transfer. The device provides a high-speed interface between cards operating at LVTTL logic levels and a backplane operating at GTLP signal levels. High-speed (about three times faster than standard LVTTL or TTL) backplane operation is a direct result of GTLP's reduced output swing (<1 V), reduced input threshold levels, improved differential input, OEC™ circuitry, and TI-OPC™ circuitry. Improved GTLP OEC and TI-OPC circuits minimize bus-settling time and have been designed and tested using several backplane models. The high drive allows incident-wave switching in heavily loaded backplanes with equivalent load impedance down to 11 Ω.



Please be aware that an important notice concerning availability, standard warranty, and use in critical applications of Texas Instruments semiconductor products and disclaimers thereto appears at the end of this data sheet.

Widebus, UBT, TI-OPC, OEC, TI are trademarks of Texas Instruments.

SN74GTLPH1655
16-BIT LVTTTL-TO-GTLP ADJUSTABLE-EDGE-RATE
UNIVERSAL BUS TRANSCEIVER



SCES294C–OCTOBER 1999–REVISED MAY 2005

DESCRIPTION (CONTINUED)

GTLP is the Texas Instruments (TI™) derivative of the Gunning Transceiver Logic (GTL) JEDEC standard JESD 8-3. The ac specification of the SN74GTLPH1655 is given only at the preferred higher noise-margin GTLP, but the user has the flexibility of using this device at either GTL ($V_{TT} = 1.2\text{ V}$ and $V_{REF} = 0.8\text{ V}$) or GTLP ($V_{TT} = 1.5\text{ V}$ and $V_{REF} = 1\text{ V}$) signal levels.

Normally, the B port operates at GTLP signal levels. The A-port and control inputs operate at LVTTTL logic levels, but are 5-V tolerant and are compatible with TTL and 5-V CMOS inputs. V_{REF} is the B-port differential input reference voltage.

This device is fully specified for live-insertion applications using I_{off} , power-up 3-state, and BIAS V_{CC} . The I_{off} circuitry disables the outputs, preventing damaging current backflow through the device when it is powered down. The power-up 3-state circuitry places the outputs in the high-impedance state during power up and power down, which prevents driver conflict. The BIAS V_{CC} circuitry precharges and preconditions the B-port input/output connections, preventing disturbance of active data on the backplane during card insertion or removal, and permits true live-insertion capability.

This GTLP device features TI-OPC circuitry, which actively limits overshoot caused by improperly terminated backplanes, unevenly distributed cards, or empty slots during low-to-high signal transitions. This improves signal integrity, which allows adequate noise margin to be maintained at higher frequencies.

High-drive GTLP backplane interface devices feature adjustable edge-rate control (ERC). Changing the ERC input voltage between GND and V_{CC} adjusts the B-port output rise and fall times. This allows the designer to optimize system data-transfer rate and signal integrity to the backplane load.

Active bus-hold circuitry holds unused or undriven LVTTTL data inputs at a valid logic state. Use of pullup or pulldown resistors with the bus-hold circuitry is not recommended.

When V_{CC} is between 0 and 1.5 V, the device is in the high-impedance state during power up or power down. However, to ensure the high-impedance state above 1.5 V, the output-enable (\overline{OE}) input should be tied to V_{CC} through a pullup resistor; the minimum value of the resistor is determined by the current-sinking capability of the driver.

ORDERING INFORMATION

T_A	PACKAGE ⁽¹⁾		ORDERABLE PART NUMBER	TOP-SIDE MARKING
–40°C to 85°C	TSSOP – DGG	Tape and reel	SN74GTLPH1655DGGR	GTLPH1655

(1) Package drawings, standard packing quantities, thermal data, symbolization, and PCB design guidelines are available at www.ti.com/sc/package.

FUNCTIONAL DESCRIPTION

The SN74GTLPH1655 is a high-drive (100 mA), 16-bit UBT transceiver containing D-type latches and D-type flip-flops for data-path operation in transparent, latched, or clocked modes. The device is uniquely partitioned as two 8-bit transceivers with individual latch timing and output signals and a common clock for both transceiver words. It can replace any of the functions shown in Table 1. Data polarity is noninverting.

Table 1. SN74GTLPH1655 UBT Transceiver Replacement Functions

FUNCTION	8 BIT	9 BIT	10 BIT	16 BIT
Transceiver	'245, '623, '645	'863	'861	'16245, '16623
Buffer/driver	'241, '244, '541		'827	'16241, '16244, '16541
Latched transceiver	'543			'16543
Latch	'373, '573	'843	'841	'16373
Registered transceiver	'646, '652			'16646, '16652
Flip-flop	'374, '574		'821	'16374
SN74GTLPH1655 UBT transceiver replaces all above functions				

FUNCTIONAL DESCRIPTION (CONTINUED)

Data flow for each word is determined by the respective latch enables (\overline{xLEAB} and $xLEBA$), output enables (\overline{xOEAB} and $xOEBA$), and clock (CLK). The output enables ($1\overline{OEAB}$, $1\overline{OEBA}$, $2\overline{OEAB}$, and $2\overline{OEBA}$) control byte 1 and byte 2 data for the A-to-B and B-to-A directions, respectively. Note that CLK is common to both directions and both 8-bit words. \overline{OE} also is common and disables all I/O ports simultaneously.

For A-to-B data flow, the devices operate in the transparent mode when LEAB is high. When LEAB transitions low, the A data is latched independent of CLK high or low. If LEAB is low, the A data is registered on the CLK low-to-high transition. When \overline{OEAB} is low, the outputs are active. With \overline{OEAB} high, the outputs are in the high-impedance state.

The data flow for the B-to-A direction is identical, except \overline{OEBA} , LEBA, and CLK are used.

FUNCTION TABLES

FUNCTION⁽¹⁾

INPUTS				OUTPUT B	MODE
\overline{OEAB}	LEAB	CLK	A		
H	X	X	X	Z	Isolation
L	L	H	X	$B_0^{(2)}$	Latched storage of A data
L	L	L	X	$B_0^{(3)}$	
L	H	X	L	L	True transparent
L	H	X	H	H	
L	L	↑	L	L	Clocked storage of A data
L	L	↑	H	H	

- (1) A-to-B data flow is shown. B-to-A flow is similar, but uses \overline{OEBA} , LEBA, and CLK. The condition when \overline{OEAB} and \overline{OEBA} are both low at the same time is not recommended.
- (2) Output level before the indicated steady-state input conditions were established, provided that CLK was high before LEAB went low
- (3) Output level before the indicated steady-state input conditions were established

OUTPUT ENABLE

INPUTS			OUTPUTS	
\overline{OE}	\overline{OEAB}	\overline{OEBA}	A PORT	B PORT
L	L	L	Active	Active ⁽¹⁾
L	L	H	Z	Active
L	H	L	Active	Z
L	H	H	Z	Z
H	X	X	Z	Z

- (1) This condition is not recommended.

B-PORT EDGE-RATE CONTROL (ERC)

INPUT ERC		OUTPUT B-PORT EDGE RATE
LOGIC LEVEL	NOMINAL VOLTAGE	
H	V_{CC}	Slow
L	GND	Fast

SN74GTLPH1655
16-BIT LVTTTL-TO-GTLP ADJUSTABLE-EDGE-RATE
UNIVERSAL BUS TRANSCEIVER

SCES294C—OCTOBER 1999—REVISED MAY 2005

LOGIC DIAGRAM (POSITIVE LOGIC)

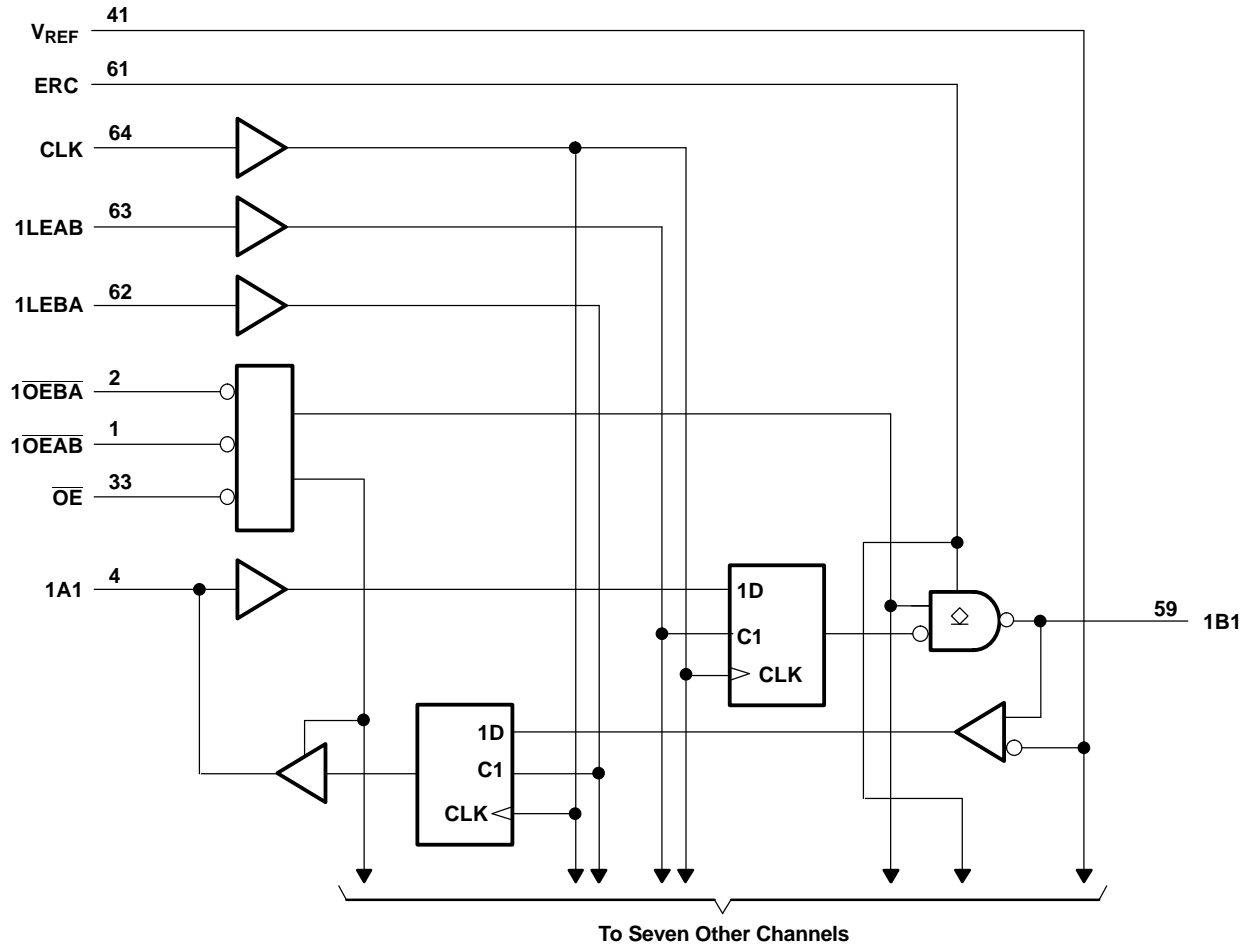

LOGIC DIAGRAM (POSITIVE LOGIC) (CONTINUED)

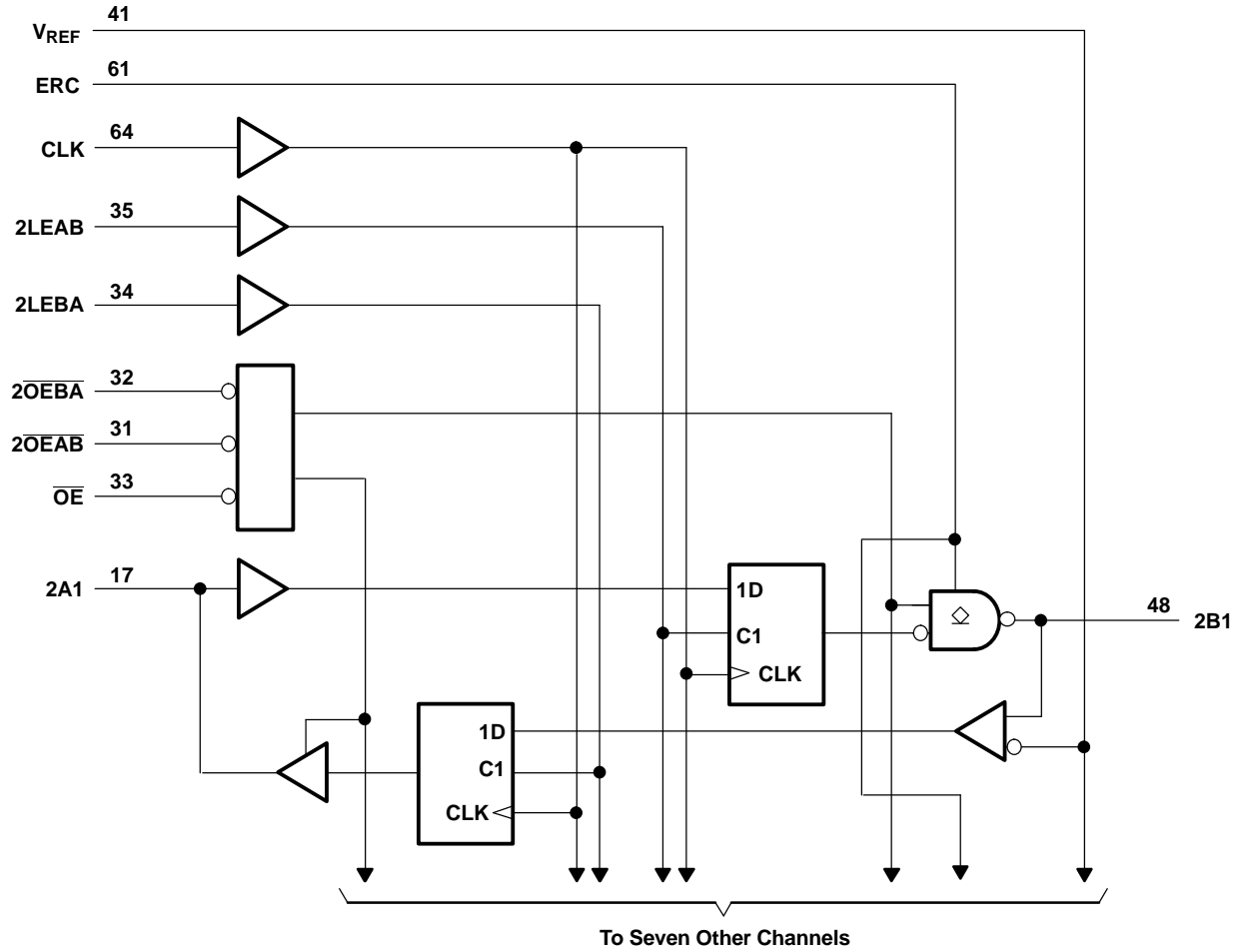

SN74GTLPH1655
16-BIT LVTTTL-TO-GTLP ADJUSTABLE-EDGE-RATE
UNIVERSAL BUS TRANSCEIVER

SCES294C—OCTOBER 1999—REVISED MAY 2005

Absolute Maximum Ratings⁽¹⁾

over operating free-air temperature range (unless otherwise noted)

		MIN	MAX	UNIT	
V_{CC} BIAS V_{CC}	Supply voltage range	-0.5	4.6	V	
V_I	Input voltage range ⁽²⁾	A port, \overline{ERC} , and control inputs	-0.5	7	V
		B port and V_{REF}	-0.5	4.6	
V_O	Voltage range applied to any output in the high-impedance or power-off state ⁽²⁾	A port	-0.5	7	V
		B port	-0.5	4.6	
I_O	Current into any output in the low state	A port		48	mA
		B port		200	
I_O	Current into any A-port output in the high state ⁽³⁾		48	mA	
	Continuous current through each V_{CC} or GND		± 100	mA	
I_{IK}	Input clamp current	$V_I < 0$	-50	mA	
I_{OK}	Output clamp current	$V_O < 0$	-50	mA	
θ_{JA}	Package thermal impedance ⁽⁴⁾		55	$^{\circ}C/W$	
T_{stg}	Storage temperature range	-65	150	$^{\circ}C$	

- (1) Stresses beyond those listed under "absolute maximum ratings" may cause permanent damage to the device. These are stress ratings only, and functional operation of the device at these or any other conditions beyond those indicated under "recommended operating conditions" is not implied. Exposure to absolute-maximum-rated conditions for extended periods may affect device reliability.
- (2) The input and output negative-voltage ratings may be exceeded if the input and output clamp-current ratings are observed.
- (3) This current flows only when the output is in the high state and $V_O > V_{CC}$.
- (4) The package thermal impedance is calculated in accordance with JESD 51-7.

Recommended Operating Conditions⁽¹⁾⁽²⁾⁽³⁾⁽⁴⁾

			MIN	NOM	MAX	UNIT
V_{CC} , BIAS V_{CC}	Supply voltage		3.15	3.3	3.45	V
V_{TT}	Termination voltage	GTL	1.14	1.2	1.26	V
		GTLP	1.35	1.5	1.65	
V_{REF}	Reference voltage	GTL	0.74	0.8	0.87	V
		GTLP	0.87	1	1.1	
V_I	Input voltage	B port			V_{TT}	V
		Except B port		V_{CC}	5.5	
V_{IH}	High-level input voltage	B port	$V_{REF} + 0.05$			V
		ERC	$V_{CC} - 0.6$	V_{CC}	5.5	
		Except B port and ERC	2			
V_{IL}	Low-level input voltage	B port	$V_{REF} - 0.05$			V
		ERC	GND			
		Except B port and ERC	0.8			
I_{IK}	Input clamp current				-18	mA
I_{OH}	High-level output current	A port			-24	mA
I_{OL}	Low-level output current	A port			24	mA
		B port			100	
$\Delta t/\Delta v$	Input transition rise or fall rate	Outputs enabled			10	ns/V
$\Delta t/\Delta V_{CC}$	Power-up ramp rate		20			μ s/V
T_A	Operating free-air temperature		-40		85	$^{\circ}$ C

- (1) All unused control and B-port inputs of the device must be held at V_{CC} or GND to ensure proper device operation. Refer to the TI application report, *Implications of Slow or Floating CMOS Inputs*, literature number SCBA004.
- (2) Proper connection sequence for use of the B-port I/O precharge feature is GND and BIAS $V_{CC} = 3.3$ V first, I/O second, and $V_{CC} = 3.3$ V last, because the BIAS V_{CC} precharge circuitry is disabled when any V_{CC} pin is connected. The control and V_{REF} inputs can be connected anytime, but normally are connected during the I/O stage. If B-port precharge is not required, any connection sequence is acceptable, but generally, GND is connected first.
- (3) V_{TT} and R_{TT} can be adjusted to accommodate backplane impedances if the dc recommended I_{OL} ratings are not exceeded.
- (4) V_{REF} can be adjusted to optimize noise margins, but normally is two-thirds V_{TT} . TI-OPC circuitry is enabled in the A-to-B direction and is activated when $V_{TT} > 0.7$ V above V_{REF} . If operated in the A-to-B direction, V_{REF} should be set to within 0.6 V of V_{TT} to minimize current drain.

Electrical Characteristics

over recommended operating free-air temperature range for GTLP (unless otherwise noted)

PARAMETER		TEST CONDITIONS			MIN	TYP ⁽¹⁾	MAX	UNIT
V_{IK}		$V_{CC} = 3.15\text{ V}$,	$I_I = -18\text{ mA}$				-1.2	V
V_{OH}	A port	$V_{CC} = 3.15\text{ V to }3.45\text{ V}$,	$I_{OH} = -100\text{ }\mu\text{A}$		$V_{CC} - 0.2$			V
		$V_{CC} = 3.15\text{ V}$	$I_{OH} = -12\text{ mA}$		2.4			
			$I_{OH} = -24\text{ mA}$		2			
V_{OL}	A port	$V_{CC} = 3.15\text{ V to }3.45\text{ V}$,	$I_{OL} = 100\text{ }\mu\text{A}$				0.2	V
		$V_{CC} = 3.15\text{ V}$	$I_{OL} = 12\text{ mA}$				0.4	
			$I_{OL} = 24\text{ mA}$				0.5	
	B port	$V_{CC} = 3.15\text{ V}$	$I_{OL} = 10\text{ mA}$				0.2	
			$I_{OL} = 64\text{ mA}$				0.4	
			$I_{OL} = 100\text{ mA}$				0.55	
I_I	Control inputs	$V_{CC} = 3.45\text{ V}$,	$V_I = 0\text{ or }5.5\text{ V}$				± 10	μA
$I_{OZH}^{(2)}$	A port	$V_{CC} = 3.45\text{ V}$	$V_O = V_{CC}$				10	μA
	B port		$V_O = 1.5\text{ V}$				10	
$I_{OZL}^{(2)}$	A and B ports	$V_{CC} = 3.45\text{ V}$,	$V_O = \text{GND}$				-10	μA
$I_{BHL}^{(3)}$	A port	$V_{CC} = 3.15\text{ V}$,	$V_I = 0.8\text{ V}$				75	μA
$I_{BHH}^{(4)}$	A port	$V_{CC} = 3.15\text{ V}$,	$V_I = 2\text{ V}$				-75	μA
$I_{BHLO}^{(5)}$	A port	$V_{CC} = 3.45\text{ V}$,	$V_I = 0\text{ to }V_{CC}$				500	μA
$I_{BHHO}^{(6)}$	A port	$V_{CC} = 3.45\text{ V}$,	$V_I = 0\text{ to }V_{CC}$				-500	μA
I_{CC}	A or B port	$V_{CC} = 3.45\text{ V}$, $I_O = 0$, V_I (A-port or control input) = V_{CC} or GND, V_I (B port) = V_{TT} or GND	Outputs high				40	mA
			Outputs low				40	
			Outputs disabled				40	
$\Delta I_{CC}^{(7)}$		$V_{CC} = 3.45\text{ V}$, One A-port or control input at $V_{CC} - 0.6\text{ V}$, Other A-port or control inputs at V_{CC} or GND					1.5	mA
C_i	Control inputs	$V_I = 3.15\text{ V or }0$					4.5 6.5	pF
C_{io}	A port	$V_O = 3.15\text{ V or }0$					6.5 7.5	pF
	B port	$V_O = 1.5\text{ V or }0$					8.5 10.5	

(1) All typical values are at $V_{CC} = 3.3\text{ V}$, $T_A = 25^\circ\text{C}$.

(2) For I/O ports, the parameters I_{OZH} and I_{OZL} include the input leakage current.

(3) The bus-hold circuit can sink at least the minimum low sustaining current at V_{ILmax} . I_{BHL} should be measured after lowering V_{IN} to GND and then raising it to V_{ILmax} .

(4) The bus-hold circuit can source at least the minimum high sustaining current at V_{IHmin} . I_{BHH} should be measured after raising V_{IN} to V_{CC} and then lowering it to V_{IHmin} .

(5) An external driver must source at least I_{BHLO} to switch this node from low to high.

(6) An external driver must sink at least I_{BHHO} to switch this node from high to low.

(7) This is the increase in supply current for each input that is at the specified TTL voltage level, rather than V_{CC} or GND.

Hot-Insertion Specifications for A Port

over operating free-air temperature range

PARAMETER	TEST CONDITIONS			MIN	MAX	UNIT
I_{off}	$V_{CC} = 0$,	BIAS $V_{CC} = 0$,	V_I or $V_O = 0\text{ to }5.5\text{ V}$		10	μA
I_{OZPU}	$V_{CC} = 0\text{ to }1.5\text{ V}$,	$V_O = 0.5\text{ V to }3\text{ V}$,	$\overline{OE} = 0$		± 30	μA
I_{OZPD}	$V_{CC} = 1.5\text{ V to }0$,	$V_O = 0.5\text{ V to }3\text{ V}$,	$\overline{OE} = 0$		± 30	μA

Live-Insertion Specifications for B Port

over operating free-air temperature range

PARAMETER	TEST CONDITIONS			MIN	MAX	UNIT
I_{off}	$V_{CC} = 0,$	BIAS $V_{CC} = 0,$	V_I or $V_O = 0$ to 1.5 V		10	μA
I_{OZPU}	$V_{CC} = 0$ to 1.5 V,	BIAS $V_{CC} = 0,$	$V_O = 0.5$ V to 1.5 V, $\overline{OE} = 0$		± 30	μA
I_{OZPD}	$V_{CC} = 1.5$ V to 0,	BIAS $V_{CC} = 0,$	$V_O = 0.5$ V to 1.5 V, $\overline{OE} = 0$		± 30	μA
I_{CC} (BIAS V_{CC})	$V_{CC} = 0$ to 3.15 V	BIAS $V_{CC} = 3.15$ V to 3.45 V,	V_O (B port) = 0 to 1.5 V		5	mA
	$V_{CC} = 3.15$ V to 3.45 V				10	μA
V_O	$V_{CC} = 0,$	BIAS $V_{CC} = 3.3$ V	$I_O = 0$	0.95	1.05	V
I_O	$V_{CC} = 0,$	BIAS $V_{CC} = 3.15$ V to 3.45 V,	V_O (B port) = 0.6 V	-1		μA

Timing Requirements

over recommended ranges of supply voltage and operating free-air temperature,
 $V_{TT} = 1.5$ V and $V_{REF} = 1$ V for GTLP (unless otherwise noted)

		MIN	MAX	UNIT
f_{clock}	Clock frequency		175	MHz
t_w	Pulse duration	LEAB or LEBA high	3	ns
		CLK high or low	3	
t_{su}	Setup time	A before CLK	3	ns
		B before CLK	3	
		A before LEAB \downarrow , CLK = don't care	2.5	
		B before LEBA \downarrow , CLK = don't care	2.5	
t_h	Hold time	A after CLK	0.5	ns
		B after CLK	0.5	
		A after LEAB \downarrow , CLK = don't care	0.5	
		B after LEBA \downarrow , CLK = don't care	0.5	

SN74GTLPH1655
16-BIT LVTTTL-TO-GTLP ADJUSTABLE-EDGE-RATE
UNIVERSAL BUS TRANSCEIVER

SCES294C—OCTOBER 1999—REVISED MAY 2005

Switching Characteristics

over recommended ranges of supply voltage and operating free-air temperature,
 $V_{TT} = 1.5\text{ V}$ and $V_{REF} = 1\text{ V}$ for GTLP (see Figure 1)

PARAMETER	FROM (INPUT)	TO (OUTPUT)	EDGE RATE ⁽¹⁾	MIN	TYP ⁽²⁾	MAX	UNIT
f_{max}				175			MHz
t_{PLH}	A	B	Slow	3.5		7.7	ns
t_{PHL}				2.4	6.3		
t_{PLH}	A	B	Fast	2		6.3	ns
t_{PHL}				2	5.9		
t_{PLH}	LEAB	B	Slow	3.5		7.8	ns
t_{PHL}				2.7	6.4		
t_{PLH}	LEAB	B	Fast	2		6.4	ns
t_{PHL}				2	6		
t_{PLH}	CLK	B	Slow	4.7		8	ns
t_{PHL}				2.7	6.4		
t_{PLH}	CLK	B	Fast	3.6		6.8	ns
t_{PHL}				2	6.1		
t_{en}	\overline{OE}	B	Slow	3.5		7.3	ns
t_{dis}				3.5	7		
t_{en}	\overline{OE}	B	Fast	2		6	ns
t_{dis}				2	6.6		
t_{en}	\overline{OEAB}	B	Slow	3.5		7.4	ns
t_{dis}				3.5	7		
t_{en}	\overline{OEAB}	B	Fast	2		6.1	ns
t_{dis}				2	6.3		
t_r	Rise time, B outputs (20% to 80%)		Slow	2.6		ns	
			Fast	1.5			
t_f	Fall time, B outputs (80% to 20%)		Slow	3		ns	
			Fast	2.2			
t_{PLH}	B	A		1.5	5.5	ns	
t_{PHL}			1.5	5.5			
t_{PLH}	LEBA	A		1.3	5.2	ns	
t_{PHL}			1	5			
t_{PLH}	CLK	A		1.2	6.3	ns	
t_{PHL}			1	5			
t_{en}	\overline{OE}	A		1.5	5.6	ns	
t_{dis}			1.5	6.1			
t_{en}	\overline{OEBA}	A		1.2	5.4	ns	
t_{dis}			2	6.1			

(1) Slow (ERC = V_{CC}) and Fast (ERC = GND)
(2) All typical values are at $V_{CC} = 3.3\text{ V}$, $T_A = 25^\circ\text{C}$.

PARAMETER MEASUREMENT INFORMATION

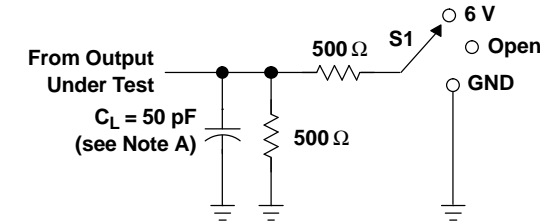

LOAD CIRCUIT FOR A OUTPUTS

TEST	S1
t_{PLH}/t_{PHL}	Open
t_{PLZ}/t_{PZL}	6 V
t_{PHZ}/t_{PZH}	GND

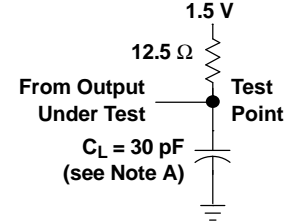

LOAD CIRCUIT FOR B OUTPUTS

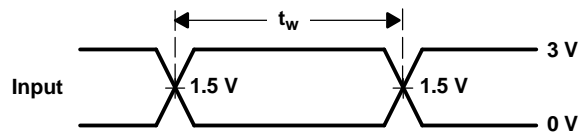

VOLTAGE WAVEFORMS
PULSE DURATION

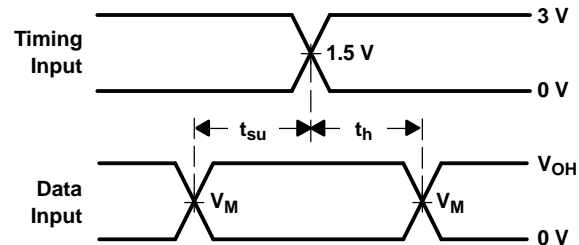

VOLTAGE WAVEFORMS
SETUP AND HOLD TIMES
($V_M = 1.5$ V for A port and 1 V for B port)
($V_{OH} = 3$ V for A port and 1.5 V for B port)

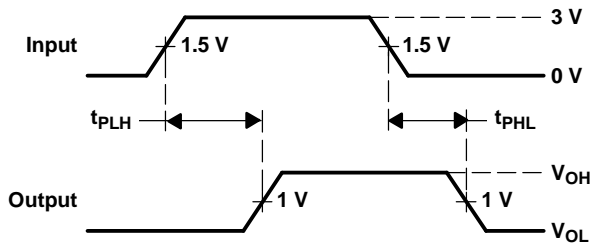

VOLTAGE WAVEFORMS
PROPAGATION DELAY TIMES
(A port to B port)

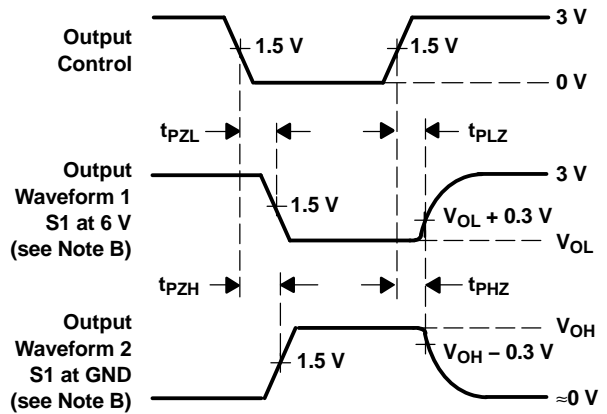

VOLTAGE WAVEFORMS
ENABLE AND DISABLE TIMES
(A port)

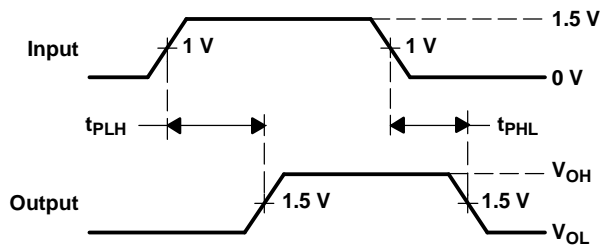

VOLTAGE WAVEFORMS
PROPAGATION DELAY TIMES
(B port to A port)

- NOTES: A. C_L includes probe and jig capacitance.
 B. Waveform 1 is for an output with internal conditions such that the output is low, except when disabled by the output control. Waveform 2 is for an output with internal conditions such that the output is high, except when disabled by the output control.
 C. All input pulses are supplied by generators having the following characteristics: PRR \approx 10 MHz, $Z_O = 50 \Omega$, $t_r \approx 2$ ns, $t_f \approx 2$ ns.
 D. The outputs are measured one at a time, with one transition per measurement.

Figure 1. Load Circuits and Voltage Waveforms

DISTRIBUTED-LOAD BACKPLANE SWITCHING CHARACTERISTICS

The preceding switching characteristics table shows the switching characteristics of the device into a lumped load (Figure 1). However, the designer's backplane application probably is a distributed load. The physical representation is shown in Figure 2. This backplane, or distributed load, can be approximated closely to a resistor inductance capacitance (RLC) circuit, as shown in Figure 3. This device has been designed for optimum performance in this RLC circuit. The following switching characteristics table shows the switching characteristics of the device into the RLC load, to help the designer better understand the performance of the GTLP device in this typical backplane. See www.ti.com/sc/gtlp for more information.

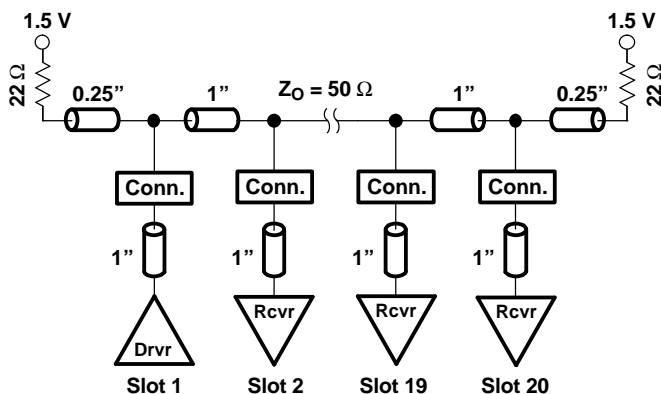

Figure 2. High-Drive Test Backplane

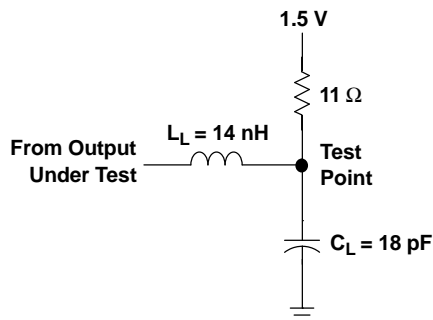

Figure 3. High-Drive RLC Network

Switching Characteristics

over recommended ranges of supply voltage and operating free-air temperature,
 $V_{TT} = 1.5\text{ V}$ and $V_{REF} = 1\text{ V}$ for GTLP (see [Figure 3](#))

PARAMETER	FROM (INPUT)	TO (OUTPUT)	EDGE RATE ⁽¹⁾	TYP ⁽²⁾	UNIT
t_{PLH}	A	B	Slow	5	ns
t_{PHL}				5	
t_{PLH}	A	B	Fast	3.8	ns
t_{PHL}				3.8	
t_{PLH}	LEAB	B	Slow	4.9	ns
t_{PHL}				4.9	
t_{PLH}	LEAB	B	Fast	3.9	ns
t_{PHL}				3.9	
t_{PLH}	CLK	B	Slow	4.8	ns
t_{PHL}				4.8	
t_{PLH}	CLK	B	Fast	3.7	ns
t_{PHL}				3.7	
t_{en}	\overline{OEAB} or \overline{OE}	B	Slow	4.9	ns
t_{dis}				4.7	
t_{en}	\overline{OEAB} or \overline{OE}	B	Fast	3.5	ns
t_{dis}				4.1	
t_r	Rise time, B outputs (20% to 80%)		Slow	2	ns
			Fast	1.2	
t_f	Fall time, B outputs (80% to 20%)		Slow	2.5	ns
			Fast	1.8	

(1) Slow (ERC = V_{CC}) and Fast (ERC = GND)

(2) All typical values are at $V_{CC} = 3.3\text{ V}$, $T_A = 25^\circ\text{C}$. All values are derived from TI-SPICE models.

PACKAGING INFORMATION

Orderable Device	Status (1)	Package Type	Package Drawing	Pins	Package Qty	Eco Plan (2)	Lead finish/ Ball material (6)	MSL Peak Temp (3)	Op Temp (°C)	Device Marking (4/5)	Samples
SN74GTLPH1655DGGR	ACTIVE	TSSOP	DGG	64	2000	RoHS & Green	NIPDAU	Level-1-260C-UNLIM	-40 to 85	GTLPH1655	Samples

(1) The marketing status values are defined as follows:

ACTIVE: Product device recommended for new designs.

LIFEBUY: TI has announced that the device will be discontinued, and a lifetime-buy period is in effect.

NRND: Not recommended for new designs. Device is in production to support existing customers, but TI does not recommend using this part in a new design.

PREVIEW: Device has been announced but is not in production. Samples may or may not be available.

OBSOLETE: TI has discontinued the production of the device.

(2) **RoHS:** TI defines "RoHS" to mean semiconductor products that are compliant with the current EU RoHS requirements for all 10 RoHS substances, including the requirement that RoHS substance do not exceed 0.1% by weight in homogeneous materials. Where designed to be soldered at high temperatures, "RoHS" products are suitable for use in specified lead-free processes. TI may reference these types of products as "Pb-Free".

RoHS Exempt: TI defines "RoHS Exempt" to mean products that contain lead but are compliant with EU RoHS pursuant to a specific EU RoHS exemption.

Green: TI defines "Green" to mean the content of Chlorine (Cl) and Bromine (Br) based flame retardants meet JS709B low halogen requirements of <=1000ppm threshold. Antimony trioxide based flame retardants must also meet the <=1000ppm threshold requirement.

(3) MSL, Peak Temp. - The Moisture Sensitivity Level rating according to the JEDEC industry standard classifications, and peak solder temperature.

(4) There may be additional marking, which relates to the logo, the lot trace code information, or the environmental category on the device.

(5) Multiple Device Markings will be inside parentheses. Only one Device Marking contained in parentheses and separated by a "-" will appear on a device. If a line is indented then it is a continuation of the previous line and the two combined represent the entire Device Marking for that device.

(6) Lead finish/Ball material - Orderable Devices may have multiple material finish options. Finish options are separated by a vertical ruled line. Lead finish/Ball material values may wrap to two lines if the finish value exceeds the maximum column width.

Important Information and Disclaimer:The information provided on this page represents TI's knowledge and belief as of the date that it is provided. TI bases its knowledge and belief on information provided by third parties, and makes no representation or warranty as to the accuracy of such information. Efforts are underway to better integrate information from third parties. TI has taken and continues to take reasonable steps to provide representative and accurate information but may not have conducted destructive testing or chemical analysis on incoming materials and chemicals. TI and TI suppliers consider certain information to be proprietary, and thus CAS numbers and other limited information may not be available for release.

In no event shall TI's liability arising out of such information exceed the total purchase price of the TI part(s) at issue in this document sold by TI to Customer on an annual basis.

DGG (R-PDSO-G**)

PLASTIC SMALL-OUTLINE PACKAGE

48 PINS SHOWN



- NOTES: A. All linear dimensions are in millimeters.
 B. This drawing is subject to change without notice.
 C. Body dimensions do not include mold protrusion not to exceed 0,15.
 D. Falls within JEDEC MO-153

IMPORTANT NOTICE AND DISCLAIMER

TI PROVIDES TECHNICAL AND RELIABILITY DATA (INCLUDING DATASHEETS), DESIGN RESOURCES (INCLUDING REFERENCE DESIGNS), APPLICATION OR OTHER DESIGN ADVICE, WEB TOOLS, SAFETY INFORMATION, AND OTHER RESOURCES "AS IS" AND WITH ALL FAULTS, AND DISCLAIMS ALL WARRANTIES, EXPRESS AND IMPLIED, INCLUDING WITHOUT LIMITATION ANY IMPLIED WARRANTIES OF MERCHANTABILITY, FITNESS FOR A PARTICULAR PURPOSE OR NON-INFRINGEMENT OF THIRD PARTY INTELLECTUAL PROPERTY RIGHTS.

These resources are intended for skilled developers designing with TI products. You are solely responsible for (1) selecting the appropriate TI products for your application, (2) designing, validating and testing your application, and (3) ensuring your application meets applicable standards, and any other safety, security, or other requirements. These resources are subject to change without notice. TI grants you permission to use these resources only for development of an application that uses the TI products described in the resource. Other reproduction and display of these resources is prohibited. No license is granted to any other TI intellectual property right or to any third party intellectual property right. TI disclaims responsibility for, and you will fully indemnify TI and its representatives against, any claims, damages, costs, losses, and liabilities arising out of your use of these resources.

TI's products are provided subject to TI's Terms of Sale (www.ti.com/legal/termsofsale.html) or other applicable terms available either on ti.com or provided in conjunction with such TI products. TI's provision of these resources does not expand or otherwise alter TI's applicable warranties or warranty disclaimers for TI products.

Mailing Address: Texas Instruments, Post Office Box 655303, Dallas, Texas 75265
Copyright © 2020, Texas Instruments Incorporated