

TPS43331-Q1 双路开关和线性稳压器

1 特性

- 符合汽车应用 要求
- 具有符合 AEC-Q100 标准的下列结果：
 - 器件温度 1 级：-40°C 至 +125°C 的环境运行温度范围
 - 器件 HBM ESD 分类等级 2
- 输入工作范围为 5V 至 30V (VBAT)
- 两个可调节输出电压降压开关电压稳压器
- 外部时钟输入
- 降压稳压器的软启动控制
- 可编程线性稳压器 (VSTBY)，低静态电流 (65 μ A 典型值)
- 可编程线性稳压器 (VLR)
- 过压检测和关断
- 受保护的高侧驱动输出 (HSD)
- 备用稳压器的上电复位 (VSTBY)
- 串行通信，I²C 接口
- 具有可编程输入阈值的低电压警告检测 (LVWIN、VBATW)
- 使能功能，控制 VBUCK 1
- VSTBY 的可编程电源状态良好指示延迟时间 (PGDLY)
- 针对所有稳压器和高侧驱动器输出的电流限制和独立热检测及关断保护
- 热增强型 38 引脚 DAP PowerPAD™ 封装

简化原理图

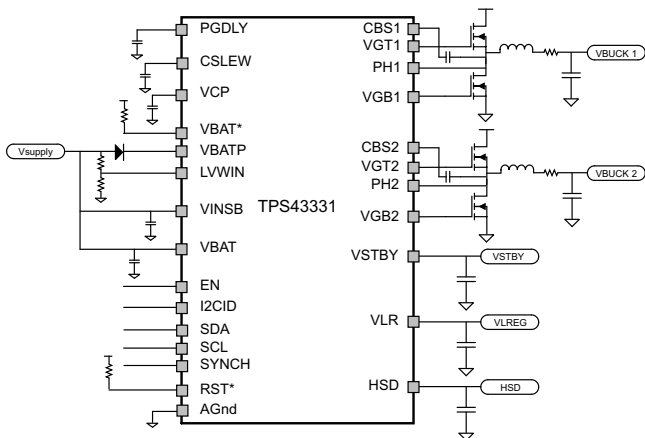

Copyright © 2017, Texas Instruments Incorporated

2 应用

- 汽车 应用
- 适用于微控制器和 DSP 的电源

3 说明

TPS43331-Q1 是一款多轨输出电压稳压器，具有两个同步开关模式控制器和两个线性稳压器。此外，有反向保护高侧开关和电压监控器（用于监控备用稳压器和输入电压）。稳压器输出和高侧开关对有些输入通过离散输入进行控制，而对不受离散输入控制的输出则使用由 I²C 配置的串行接口进行控制。

备用线性稳压器 (VSTBY) 可以承受高电压并且可以直接连接至汽车电池，静态电流通常为 65 μ A，可保持轻负载下的稳压输出。

器件信息⁽¹⁾

器件型号	封装	封装尺寸 (标称值)
TPS43331-Q1	HTSSOP (38)	12.50mm x 6.10mm

(1) 如需了解所有可用封装，请参阅数据表末尾的可订购产品附录。

效率与负载电流 (输出电压 = 5V)

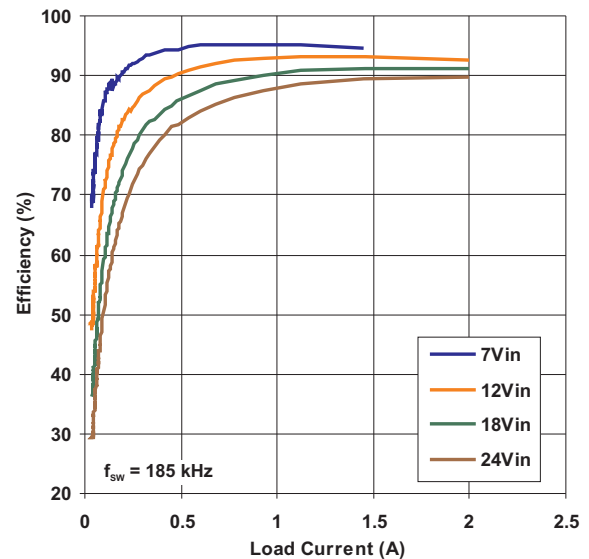

目录

<p>1 特性 1</p> <p>2 应用 1</p> <p>3 说明 1</p> <p>4 修订历史记录 2</p> <p>5 Pin Configuration and Functions 3</p> <p>6 Specifications 4</p> <p> 6.1 Absolute Maximum Ratings 4</p> <p> 6.2 ESD Ratings 4</p> <p> 6.3 Recommended Operating Conditions 5</p> <p> 6.4 Thermal Information 5</p> <p> 6.5 DC Electrical Characteristics 5</p> <p> 6.6 I²C Interface Electrical Characteristics 7</p> <p> 6.7 Switching Regulators Electrical Characteristics 8</p> <p> 6.8 Standby Regulator (VSTBY) Electrical Characteristics 9</p> <p> 6.9 Linear Regulator (VLR) Electrical Characteristics 10</p> <p> 6.10 High-Side Driver (HSD) Electrical Characteristics 11</p> <p> 6.11 AC Switching Characteristics 11</p> <p> 6.12 I²C Interface Switching Characteristics 12</p> <p> 6.13 Switching Regulators Switching Characteristics 12</p> <p> 6.14 Linear Regulator Switching Characteristics 13</p> <p> 6.15 High-Side Driver (HSD) Switching Characteristics 13</p> <p> 6.16 Timing and Switching Diagrams 14</p> <p> 6.17 Typical Characteristics 18</p>	<p>7 Detailed Description 20</p> <p> 7.1 Overview 20</p> <p> 7.2 Functional Block Diagram 21</p> <p> 7.3 Feature Description 21</p> <p> 7.4 Device Functional Modes 26</p> <p> 7.5 Programming 27</p> <p> 7.6 Register Map 29</p> <p>8 Application and Implementation 30</p> <p> 8.1 Application Information 30</p> <p> 8.2 Typical Application 30</p> <p> 8.3 System Example 43</p> <p>9 Power Supply Recommendations 44</p> <p>10 Layout 44</p> <p> 10.1 Layout Guidelines 44</p> <p> 10.2 Layout Example 44</p> <p> 10.3 Power Dissipation Derating 45</p> <p>11 器件和文档支持 46</p> <p> 11.1 文档支持 46</p> <p> 11.2 接收文档更新通知 46</p> <p> 11.3 社区资源 46</p> <p> 11.4 商标 46</p> <p> 11.5 静电放电警告 46</p> <p> 11.6 Glossary 46</p> <p>12 机械、封装和可订购信息 46</p>
--	---

4 修订历史记录

注：之前版本的页码可能与当前版本有所不同。

Changes from Revision A (September 2015) to Revision B	Page
• 已添加 将汽车 特性添加到了 “特性” 部分 1	1
• Changed the values for the linear regulator and standby regulator in the <i>Recommended Operating Conditions</i> table 5	5
• Added the VBAT = 6 V test condition and change V _{UVLO} to 9 V in the battery < 18 V test condition for the battery input leakage current parameter in the <i>DC Electrical Characteristics</i> table 5	5
• Added back the 18-V test condition (8% maximum) for the VSTBY parameter 9	9
• Added to the <i>Charge Pump Capacitor Input (VCP)</i> section 23	23
• Updated some of the symbols in the <i>Detailed Design Procedure</i> section 32	32
• 已添加 接收文档更新通知 部分 46	46
• 已更改 静电放电注意事项声明 46	46

Changes from Original (December 2009) to Revision A	Page
• 已添加 <i>ESD</i> 额定值表, 特性 说明 部分、器件功能模式、应用和实施 部分、电源相关建议 部分、布局 部分、器件和文档支持 部分以及机械、封装和可订购信息 部分。 1	1
• Added <i>Thermal Information</i> table 5	5
• Deleted parameter V _{STBY} = 18 for 8 MAX 9	9
• Changed Input voltage in Table 3 32	32
• Changed VBUCK 1 to IBUCK 1 in Table 3 32	32
• Changed VBUCK 2 to IBUCK 2 in Table 3 32	32

5 Pin Configuration and Functions

DAP Package
28-Pin HTSSOP With PowerPAD
Top View

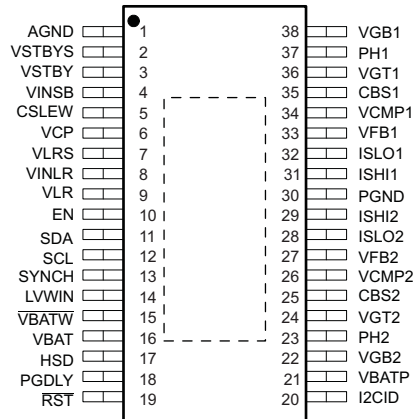

Pin Functions

PIN		I/O	DEFAULT STATE	DESCRIPTION
NO.	NAME			
1	AGND	Ground	—	Analog ground reference
2	VSTBYS	I	—	Voltage feedback for standby regulator
3	VSTBY	O	—	Regulated output, for standby and normal mode
4	VINSB	Power	—	Power input for standby regulator
5	CSLEW	O	Low	Capacitor to control VSTBY slew rate
6	VCP	I	—	Storage capacitor for charge pump
7	VLRS	I	—	Voltage feedback for switched linear regulator
8	VINLR	Power	—	Input power for switched linear regulator
9	VLR	O	—	Linear regulator output, switched using serial interface
10	EN	I	Low	Input command for active mode
11	SDA	I/O	—	Serial bidirectional data line for I ² C
12	SCL	I	—	Serial clock input for synchronization of data communications for I ² C
13	SYNCH	I	Low	External clock input for synchronization of switching frequency for SMPS
14	LVWIN	I	—	Low-voltage warning input
15	VBATW	O	Open	Battery voltage warning output
16	VBAT	Power	—	Input power for high side driver switch
17	HSD	O	—	High side driver output
18	PGDLY	I	—	Power good delay capacitor input for VSTBY regulator
19	RST	O	Low	Low-voltage reset indicator for VSTBY (active low)
20	I2CID	I	Low	Chip Identifier for I ² C
21	VBATP	Power	—	Battery voltage input for IC with external protection for reverse connections
22	VGB2	O	Low	Low side gate drive output for channel 2 (synchronous switch)
23	PH2	I	—	Phase reference for bootstrap drive channel 2
24	VGT2	O	Low	High side gate drive output for channel 2 (synchronous switch)
25	CBS2	I	—	Bootstrap capacitor for high side gate drive channel 2
26	VCMP2	I	—	Compensation feedback for channel 2
27	VFB2	I	—	Regulated output voltage feedback for channel 2
28	ISLO2	I	—	Low side of output current sense, channel 2
29	ISH12	I	—	High side of output current sense, channel 2

Pin Functions (continued)

PIN		I/O	DEFAULT STATE	DESCRIPTION
NO.	NAME			
30	PGND	Ground	—	Power ground, switching regulator ground reference
31	ISH11	I	—	High side of output current sense, channel 1
32	ISLO1	I	—	Low side of output current sense, channel 1
33	VFB1	I	—	Regulated output voltage feedback for channel 1
34	VCMP1	I	—	Compensation feedback for channel 1
35	CBS1	I	—	Bootstrap capacitor for high side gate drive channel 1
36	VGT1	O	Low	High side gate drive output for channel 1 (synchronous switch)
37	PH1	I	—	Phase reference for bootstrap drive channel 1
38	VGB1	O	Low	Low side gate drive output for channel 1 (synchronous switch)

6 Specifications

6.1 Absolute Maximum Ratings

 over operating free-air temperature range (unless otherwise noted)⁽¹⁾⁽²⁾

		MIN	MAX	UNIT
Unregulated input ⁽³⁾	VBAT, VBATP	−0.3	40	V
Unregulated power supply ⁽³⁾	VINSB, VINLR	−0.3	40	V
High side output ⁽⁴⁾	HSD	−0.3	40	V
Low voltage warning input	LVWIN	−0.3	40	V
Switched linear regulator	VLR	−0.3	15	V
Bootstrap capacitor	VCP	−0.3	18	V
Logic level or low voltage signals	PGDLY, CSLEW, $\overline{\text{VBATW}}$, $\overline{\text{RST}}$, EN, VSTBYS, VSTBY, VLRS, SYNCH, I2CID, SCL, SDA, VCMP1, VCMP2, VFB1, VFB2 ⁽³⁾	−0.3	5.5	V
	ISH11, ISH12, ISLO1, ISLO2 ⁽³⁾	−0.3	10	
	CBS1, CBS2, VGT1, VGT2	−0.3	40	
	VGB1, VGB2	−0.3	10	
	PH1, PH2 ⁽⁴⁾	−1	40	
Operating junction temperature range, T _J		−40	150	°C
Storage temperature range, T _{stg}		−65	150	°C

(1) Stresses beyond those listed under *Absolute Maximum Ratings* may cause permanent damage to the device. These are stress ratings only, and functional operation of the device at these or any other conditions beyond those indicated under *Recommended Operating Conditions* is not implied. Exposure to absolute-maximum-rated conditions for extended periods may affect device reliability.

(2) All voltage values are with respect to GND.

(3) Absolute negative voltage on these pins not to go below −0.5 V.

(4) Absolute negative voltage on these pins not to go below −1 V, and transients of −2 V because of recirculation of an inductive load for < 100 ns.

6.2 ESD Ratings

		VALUE	UNIT
V _(ESD)	Electrostatic discharge	Human-body model (HBM), per AEC Q100-002 ⁽¹⁾	2000 V

(1) AEC Q100-002 indicates that HBM stressing shall be in accordance with the ANSI/ESDA/JEDEC JS-001 specification.

6.3 Recommended Operating Conditions

		MIN	MAX	UNIT
Unregulated input	VBAT, VBATP	5	30	V
Unregulated power supply	VINSB, VINLR	1.8	30	V
High side output	HSD	5	30	V
Low voltage warning input	LVWIN	5	30	V
Linear regulator	VLR	1.2	12	V
Standby regulator	VSTBY, VSTBYS	1.2	5	V
Bootstrap capacitor	VCP		16	V
Logic level or low voltage signals	PGDLY, CSLEW, $\overline{\text{VBATW}}$, RST, EN, VLRS, SYNCH, I2CID, SCL, SDA, VCMP1, VCMP2, VFB1, VFB2	4.5	5.3	V
	ISH11, ISH12, ISLO1, ISLO2	1.2	9	V
	CBS1, CBS2, VGT1, VGT2	5	38	V
	VGB1, VGB2	3	8	V
	PH1, PH2	-1	30	V
T _A	Operating ambient temperature ⁽¹⁾	-40	125	°C

(1) Assumes $T_A = T_J - \text{Power dissipation} \times \theta_{JA}$

6.4 Thermal Information

THERMAL METRIC ⁽¹⁾		TPS43331-Q1	UNIT
		DAP (HTSSOP)	
		38 PINS	
R _{θJA}	Junction-to-ambient thermal resistance ⁽²⁾	25	°C/W
R _{θJC(top)}	Junction-to-case (top) thermal resistance ⁽³⁾	10	°C/W
R _{θJB}	Junction-to-board thermal resistance	—	°C/W
ψ _{JT}	Junction-to-top characterization parameter	—	°C/W
ψ _{JB}	Junction-to-board characterization parameter	—	°C/W
R _{θJC(bot)}	Junction-to-case (bottom) thermal resistance	—	°C/W

(1) For more information about traditional and new thermal metrics, see the [Semiconductor and IC Package Thermal Metrics](#) application report.

(2) This assumes a JEDEC JESD 51-5 standard board with thermal vias – See the [Layout Example](#) section and the application report [PowerPAD Thermally Enhanced Package](#) for more information.

(3) This assumes junction to exposed thermal pad.

6.5 DC Electrical Characteristics

VBAT = VBATP = 6 V to 18 V, T_J = -40°C to +150°C (unless otherwise noted)

PARAMETER	TEST CONDITIONS	MIN	TYP	MAX	UNIT
VBAT Battery input					
V _{NOV}	Normal operating voltage	6		18	V
V _{JSV}	Jump start voltage	T _A = -40°C to 50°C	18	26.5	V
V _{OVSD}	Overvoltage shutdown	All outputs except standby reg are disabled,	27		V
V _{HYS}	Hysteresis		0.5		V
V _{UVLO}	Undervoltage lockout	VSTBY ref disabled, Verify < V _{OL(max)}	2	5.2	V
I _Q	Battery input leakage current	Standby mode, VBAT = 14 V, I _{VSTBY} = 100 μA, I _{Battery} - I _{VSTBY} , EN = 0 V		100	μA
		Standby mode, 9 V < VBAT < 18 V, I _{VSTBY} = -100 μA, I _{Battery} - I _{VSTBY} , EN = 0 V		130	
		Standby mode, 18 V < VBAT < 40 V, I _{VSTBY} = -100 μA, I _{Battery} - I _{VSTBY} , EN = 0 V		200	
		Standby mode, VBAT = 6 V, I _{VSTBY} = -100 μA, I _{Battery} - I _{VSTBY} , EN = 0 V		2.5	mA

DC Electrical Characteristics (continued)

 VBAT = VBATP = 6 V to 18 V, T_J = –40°C to +150°C (unless otherwise noted)

PARAMETER		TEST CONDITIONS	MIN	TYP	MAX	UNIT
I _B	Battery input bias current	VBAT = 6V to 18V, HSDEN = VLREN = SW2EN = 1, VGT2 = VGB2 = open, I _{VSTBY} = I _{VLR} = I _{HSD} = 100 μA, I _{Battery} – I _{VSTBY} – I _{VLR} – I _{HSD}			25	mA
I _B	VBAT input bias current	VBAT = 6 V to 18 V, HSDEN = 1, I _{HSD} = 100 μA, I _{VBAT} – I _{HSD}			1	mA
		VBAT = 40 V			5	
		VBAT = –20 V			–2	
LVWIN Low voltage warning input						
V _{TH}	Input high threshold		1.1		1.2	V
V _{HYS}	Hysteresis	On rising edge on input signal	70		120	mV
I _{LKG}	Input leakage current	LVWIN = 1 V to 18 V	–1		1	μA
		LVWIN = 40 V	–1		1	
VBATP Consumption current						
I _B	Supply current from VBATP line	I _{VSTBY} = 50 mA			10	mA
		SW2EN = 1, VGTX = VGBX = open			15	
		VLREN = 1, I _{VLR} = 100 μA			10	
		I _{VBATP} = I _{VLR}			10	
		VBAT = 40 V, I _{VSTBY} = 50 mA			6	
		VBAT = VINLR = Open, V _{UVLO} < VBATP = VINSB < 18 V, VLREN = SW2EN = HSDEN = 1, I _{VLR} = I _{HSD} = –100 μA, VGTX = VGBX = Open, I _{VBATP} = I _{VSTBY} + I _{VLR} + I _{HSD}			20	
CSLEW Slew rate control on standby regulator VSTBY						
I _{CSLEW}	Soft-start rate on VSTBY reg	C _{CSLEW} = 0.01 μF	–2.9		–1.45	μA
EN Enable/disable input						
V _{IH}	Enable		2			V
V _{IL}	Disable				0.8	V
V _{HYS}	Hysteresis		300		800	mV
I _{LKG}	Input leakage current		–1		1	μA
SYNCH Synchronization input voltage threshold						
V _{IH}	Enable	Switch enabled going from low to high 20% to 80%	2			V
V _{IL}	Disable	Switch disabled going from high to low 80% to 20%			0.8	V
V _{HYS}	Hysteresis		300		800	mV
R _{PD}	Input pulldown resistance		20		100	kΩ
PGDLY Power good delay						
I _{OH}	Power delay output current	PGDLY = 0, 100 pF ≤ C _{PGDLY} ≤ 0.01 μF	–2.6		–1.5	μA
V _{TH}	Input threshold	Verify $\overline{\text{RST}}$ deasserted	1.5		2.5	V
V _{SAT}	PGDLY saturation voltage	100 pF ≤ C _{PGDLY} ≤ 0.01 μF			0.4	V
$\overline{\text{RST}}$ Reset output						
V _{OL}	Reset output	0.5 V ≤ VSTBY ≤ VTH _{min} (VSTBY), I _{OL} = 1.6 mA, Active mode			0.4	V
		0.5 V ≤ VSTBY ≤ VTH _{min} (VSTBY), I _{OL} = 1.6 mA, Standby mode			0.4	V
		0.5 V ≤ VBATP ≤ VUVLO _{min} , I _{OL} = 100 μA			0.4	V
I _{Leakage}	Output leakage current	$\overline{\text{RST}}$ = VSTBY, Active and standby modes	–10		10	μA
VBATW Low input voltage warning (Battery input)						
V _{OL}	Warning output voltage	I _{OL} = 1.6 mA, Active and standby modes			0.4	V
I _{Leakage}	Output leakage current	$\overline{\text{VBATW}}$ = VSTBY, Active and standby modes	–10		10	μA

6.6 I²C Interface Electrical Characteristics

VBAT = VBATP = 6 V to 18 V, T_J = –40°C to +150°C (unless otherwise noted)

PARAMETER		TEST CONDITIONS	MIN	TYP	MAX	UNIT
I²CID Serial interface ID address input						
V _{IH}	Input high threshold		2			V
V _{IL}	Input low threshold				0.8	V
V _{HYS}	Hysteresis		0.3		0.8	V
I _{LKG}	Input leakage current	I ² CID = 3.3 V	–1		1	μA
SCL Serial clock input for synchronization						
V _{IH}	Input high threshold		2			V
V _{IL}	Input low threshold				0.8	V
V _{HYS}	Hysteresis		0.3		0.8	V
I _{LKG}	Input leakage current	0.3 V ≤ V _{SCL} ≤ 3.0 V	–1		1	μA
C _{SCLIN}	Input line capacitance				10	pF
SDA Serial communications data line						
V _{IH}	Input high threshold		2			V
V _{IL}	input low threshold				0.8	V
V _{HYS}	Hysteresis		0.3		0.8	V
I _{Leakage}	Leakage current	0.3 V ≤ V _{SDA} ≤ 3.0 V	–1		1	μA
V _{SAT}	Output saturation voltage	I _{OL} = 3 mA			0.4	V
		I _{OL} = 6 mA			0.6	V
C _{SDAIN}	Input line capacitance				10	pF

6.7 Switching Regulators Electrical Characteristics

 VBAT = VBATP = 6 V to 18 V, T_J = –40°C to +150°C (unless otherwise noted)

PARAMETER		TEST CONDITIONS	MIN	TYP	MAX	UNIT
Switch mode regulators (Channel 1)						
I _O	Output current				4	A
V _O	Regulated output voltage range		1.2		10	V
V _{FB1}	Feedback voltage input		980		1020	mV
V _{OTOL}	Regulated output voltage tolerance	I _O = 100% to 10% I _O (max), Includes external feedback resistors	–5%		5%	
V _{ISCTH}	Short circuit current, voltage threshold ⁽¹⁾		60		120	mV
V _{DO}	Dropout voltage ⁽²⁾	I _O = I _O (max), VBAT = 9 V, Includes drop due to V _{ISCTH}			400	mV
dV/dt	Output voltage soft-start slew rate ⁽³⁾	Step response on regulator enable, I _O = I _O (max)			10	V/ms
V _{P_SC}	Overshoot ⁽⁴⁾	I _O = I _{SC} (max), Remove short			5%	
V _{P_TR}	Load transient response ⁽⁴⁾	I _O = 10% to 100% I _O (max)	–5%			
		I _O = 100% to 10% I _O (max)			5%	
I _{VGT1_SRC}	Gate drive source current (high side)	VGT1 = VGB1 = 6 V, Measure time calculate current	210		330	mA
I _{VGT1_SINK}	Gate drive sink current (high side)	VGT1 = VGB1 = 6 V, Measure time calculate current	500		1020	mA
I _{VGB1_SRC}	Gate drive source current (low side)	VGT1 = VGB1 = 6 V, Measure time calculate current	90		135	mA
I _{VGB1_SINK}	Gate drive sink current (low side)	VGT1 = VGB1 = 6 V, Measure time calculate current	440		1300	mA
Switch mode regulators (Channel 2), SW2EN = 1 (unless otherwise noted)						
I _O	Output current				4.0	A
V _O	Regulated output voltage range		1.2		10	V
V _{FB1}	Feedback voltage input		980		1020	mV
V _{OTOL}	Regulated output voltage tolerance	I _O = 100% to 10% I _O (max), Includes external feedback resistors	–5%		5%	
V _{ISCTH}	Short circuit current, voltage threshold ⁽¹⁾		60		120	mV
V _{DO}	Dropout voltage ⁽²⁾	I _O = I _O (max), VBAT = 9 V, Includes drop due to V _{ISCTH}			400	mV
dV/dt	Output voltage soft-start slew rate ⁽³⁾	Step response on regulator enable, I _O = I _O (max)			10	V/ms
V _{P_SC}	Overshoot ⁽⁴⁾	I _O = I _{SC} (max), Remove short			5%	
V _{P_TR}	Load transient response ⁽⁴⁾	I _O = 10% to 100% I _O (max)	–5%			
		I _O = 100% to 10% I _O (max)			5%	
I _{VGT2_SRC}	Gate drive source current (high side)	VGT1 = VGB1 = 6 V, Measure time calculate current	210		330	mA
I _{VGT2_SINK}	Gate drive sink current (high side)	VGT1 = VGB1 = 6 V, Measure time calculate current	500		1020	mA
I _{VGB2_SRC}	Gate drive source current (low side)	VGT1 = VGB1 = 6 V, Measure time calculate current	90		135	mA
I _{VGB2_SINK}	Gate drive sink current (low side)	VGT1 = VGB1 = 6 V, Measure time calculate current	440		1300	mA

(1) The output remains stable using soft-start conditions when the output drops from regulation to 0 V. The device is not damaged by a hard short to ground.

(2) Lower VBAT until the output drops to 0.1 V. Measure VBAT – V_O.

(3) Design information – Not tested. Specified by CSLEW current and bench characterization.

(4) Design information – Not tested.

6.8 Standby Regulator (VSTBY) Electrical Characteristics

VINLR = 3 V to 18 V, VBAT = VBATP = 6 V to 18 V, T_J = –40°C to +150°C (unless otherwise noted)

PARAMETER		TEST CONDITIONS	MIN	TYP	MAX	UNIT
I _O	Output current	Active mode	5	300		mA
		Standby mode	0.05	300		
V _O	Regulated output voltage range	V _{IN} SB = (V _O + V _{DO}) to 18 V, I _O = I _O (max) ⁽¹⁾ to I _O (min), T _A = –40°C to +50°C, V _{IN} SB = 18 V to 26.5 V, I _O = I _O (max) ⁽²⁾ to I _O (min)	1.2		3.6	V
V _{STBYS}	Feedback input voltage for standby regulator		980		1020	mV
V _{STBY}	Regulated output voltage tolerance	I _O = I _O (max) to I _O (min), V _O + V _{DO} < V _{IN} SB < 18 V, 1% nominal (3% worse case) tolerance resistors	–5%		5%	
		I _O = I _O (max) to I _O (min), 18 V < V _{IN} SB < 26.5 V			8%	
LR	Load regulation	I _O = I _O (max) to I _O (min)	–4%		0%	
SR	Line regulation	I _O = I _O (max), V _O + V _{DO} < V _{IN} SB < 18 V	–4%		4%	
I _{SC}	Short circuit current limit	V _{STBY} = 0 V ⁽³⁾	310		1400	mA
V _{DO}	Dropout voltage ⁽⁴⁾	I _O = 300 mA			1200	mV
V _{LVRTH}	Low-voltage reset threshold	Lower V _O until goes low	900		950	mV
T _{SD}	Thermal shutdown ⁽⁵⁾		150		210	°C
T _{HYS}	Hysteresis		5		15	°C
ΔV/ΔT	Output voltage slew rate ⁽⁶⁾	Step response on regulator, I _O = I _O (min)			10	V/mS
V _{OP_SC}	Overshoot ⁽⁵⁾	I _O = I _{SC} (min), Remove short			5%	
V _{P_TR}	Load transient response ⁽⁵⁾	Active mode, V _{STBY} = 1.2 V, C _{VSTBY} = 1 μF, Δt = 10 μs, I _O = I _O (min) to I _O (max), I _O = I _O (max) to I _O (min)	–6%		6%	
		Active mode, V _{STBY} = 3.6 V, C _{VSTBY} = 1 μF, Δt = 10 μs, I _O = I _O (min) to I _O (max), I _O = I _O (max) to I _O (min)	–6%		6%	
		Standby mode, V _{STBY} = 1.2 V, C _{VSTBY} = 1 μF, Δt = 10 μs, I _O = –100 mA to I _O (max), I _O = I _O (max) to –100 mA	–6%		6%	
		Standby mode, V _{STBY} = 3.6 V, C _{VSTBY} = 1 μF, Δt = 10 μs, I _O = –100 mA to I _O (max), I _O = I _O (max) to –100 mA	–6%		6%	
V _{PRSS}	Power supply rejection ratio ⁽⁵⁾	I _O = 0.5 × I _O (max), f _o = 120 Hz to 10 kHz, V _{IN} SB = 14-V DC and 1-V AC (p – p)	50			dB
		I _O = 0.5 × I _O (max), f _o = 20 to 20 kHz, V _{IN} SB = 14-V DC and 1-V AC (p – p)	45			
V _N	Output noise	100-kHz low-pass filter, f _o = 20 Hz to 100 kHz, I _{VSTBY} = –5 mA			400	μV
		100-kHz low-pass filter, f _o = 20 Hz to 20 kHz, I _{VSTBY} = –5 mA			200	
t _{tr}	Output voltage transient response	I _O = I _O (min) to I _O (max), C _O (max)			40	μs
C _O	Output capacitance	C _O (nom) = 1 μF, 16 V	0.53		1.15	μF
R _{ESR}	Output capacitance ESR	f = 1 kHz, T _A = 125°C			8.75	Ω
DF	Output capacitor dissipation factor	f = 1 kHz, T _A = –40°C			1%	
		f = 1 kHz, T _A = 25°C			3.5%	
		f = 1 kHz, T _A = 125°C			5.5%	

(1) This nomenclature is meant to agree with the convention that current flow into the pin is a positive. Therefore I_O(max) is a smaller magnitude current and I_O(min) is larger magnitude current throughout the parametric tables.

(2) Design information – Not tested, parameter assured by characterization.

(3) The output remains stable using soft-start conditions when the output drops from regulation to 0 V. The IC is not damaged by a hard short to ground.

(4) Lower V_{BAT} until the output drops to 0.1 V. Measure V_{BAT} – V_O.

(5) Design information – Not tested.

(6) Design information – Not tested. Specified by CSLEW current and bench characterization.

6.9 Linear Regulator (VLR) Electrical Characteristics

VINLR = 3 V to 18 V, VBAT = VBATP = 6 V to 18 V, T_J = -40°C to +150°C (unless otherwise noted)

PARAMETER	TEST CONDITIONS	MIN	TYP	MAX	UNIT	
I _O	Output current	5		650	mA	
V _O	Regulated output voltage range	VINLR = (V _O + V _{DO}) to 18 V, I _O = I _O (max) to I _O (min), T _A = -40°C to +50°C, VINLR = 18 V to 26.5 V, I _O = I _O (max) to I _O (min)		1.2	8.5	V
V _{LRS}	Feedback input voltage	980		1020	mV	
V _{LR}	Output voltage tolerance	I _O = I _O (max) to I _O (min), V _O + V _{DO} < VINLR < 18 V, 1% nominal (3% worse case) tolerance resistors		-5%	5%	
		I _O = I _O (max) to I _O (min), VINLR = 18 V to 26.5 V			8%	
LR	Load regulation	I _O = I _O (max) to I _O (min)		-4%	1%	
SR	Line regulation	I _O = I _O (max), V _O + V _{DO} < VINLR < 18 V		-4%	4%	
		I _O = I _O (max), 18 V < VINLR < 26.5 V		-4%	4%	
I _{SC}	Short circuit current limit	V _{LR} = 0 V ⁽¹⁾		0.7	2.7	A
V _{DO}	Dropout voltage ⁽²⁾	I _O = -200 mA			400	mV
		I _O = -600 mA			1.7	V
T _{SD}	Thermal shutdown ⁽³⁾	150		210	°C	
T _{HYS}	Hysteresis	5		15	°C	
V _{OP_SC}	Overshoot	I _O = I _{SC} (min), Remove short			5%	
V _{P_TR}	Load transient response ⁽³⁾	VLR = 1.2 V, C _{VLR} = 1 μF, Δt = 10 μs, I _O = I _O (min) to I _O (max), I _O = I _O (max) to I _O (min)		-6%	6%	
		VLR = 8.5 V, C _{VLR} = 1 μF, Δt = 10 μs, I _O = I _O (min) to I _O (max), I _O = I _O (max) to I _O (min)		-6%	6%	
V _{PRSS}	Power supply rejection ratio ⁽³⁾	I _O = 0.5 × I _O (max), f _o = 120 Hz to 10 kHz, VINLR = 14-V DC and 1-V AC (p - p)		50		dB
		I _O = 0.5 × I _O (max), f _o = 20 Hz to 20 kHz, VINLR = 14-V DC and 1-V AC (p - p)		45		
V _N	Output noise ⁽³⁾	100-kHz low-pass filter, f _o = 20 Hz to 100 kHz, I _{VLR} = -5 mA			400	μV
		Weighted filter, f _o = 20 Hz to 20 kHz, I _{VLR} = -5 mA			200	
t _{tr}	Output voltage transient response ⁽³⁾	I _O = I _O (min) to I _O (max), C _O (max)			40	μs
C _O	Output capacitance ⁽³⁾	C _O (nom) = 1 μF, 16 V		0.53	1.15	μF
R _{ESR}	Output capacitance ESR ⁽³⁾	f = 1 kHz, T _A = 125°C			8.75	Ω
DF	Output capacitor dissipation factor ⁽³⁾	f = 1 kHz, T _A = -40°C			1%	
		f = 1 kHz, T _A = 25°C			3.5%	
		f = 1 kHz, T _A = 125°C			5.5%	

- (1) The output remains stable using soft-start conditions when the output drops from regulation to 0 V. The IC is not damaged by a hard short to ground.
- (2) Lower VBAT until the output drops to 0.1 V. Measure VBAT - V_O.
- (3) Design information - Not tested

6.10 High-Side Driver (HSD) Electrical Characteristics

VBAT = VBATP = 6 V to 18 V, HSD1EN = 1, T_J = -40°C to +150°C (unless otherwise noted)

PARAMETER		TEST CONDITIONS	MIN	TYP	MAX	UNIT
V _{SAT}	HSD output saturation voltage	I _{HSD} = -300 mA			0.6	V
		I _{HSD} = -450 mA, t = 0.5 s			1.2	V
I _{LKG}	Leakage current	HSD1EN = 0, HSD = 0 V	-5		5	μA
		HSD1EN = 0, R _{HSD} = 20 Ω to -1 V	-100			μA
		HSD1EN = 0, VBAT = HSD	-100		100	μA
		HSD1EN = 0, VBAT = HSD = 34 V	-100		100	μA
		VBAT = open, C _{VBAT} = 1 mF, HSD = 18 V	0		10	mA
		GND = open, R _{HSD} = 20 Ω to -1 V			(1)15	mA
I _{STG}	High-side short circuit current	HSD = 0 V	0.310		1.4	A
		HSD = VBAT	-2		2 ⁽²⁾	mA
T _{SD}	HSD thermal shutdown ⁽³⁾	I _{HSD} = -100 μA	150		190	°C
T _{HYS}	Hysteresis		5		15	°C

(1) The condition does not damage the IC or any external components connected to the IC.

(2) The limits are based on characterization. This condition does not damage the IC and or any external components connected to the IC.

(3) Design information – Not tested

6.11 AC Switching Characteristics

VBAT = VBATP = 6 V to 18 V, T_J = -40°C to +150°C (unless otherwise noted) (see [Figure 1](#) and [Figure 2](#))

NO.	PARAMETER	TEST CONDITIONS	MIN	TYP	MAX	UNIT
RST Reset timing						
1	t _{enrst} Reset enable time		0			μs
2	t _{PGDLY} Reset delay time	CPGDLY(nom) = 100 pF	25		100	μs
3	t _{por} Internal power on reset	VSTBY in regulation to $\overline{\text{RST}}$ deasserted delay			5	ms
4	t _f Reset fall time	C _{RST} = 50 pF			2	μs
VSTBY Standby regulator de-glitch timer						
5	t _{ivcp} De-glitch filter time		5		20	μs
PGDLY Power good discharge time						
	t _{dch} Power good delay capacitor discharge time	CPGDLY = 0.01 μF			1	μs
VBATW low input voltage warning						
6	t _{prlvw} Low voltage rising output indicator propagation delay				1	μs
7	t _{pfovsd} Overvoltage shutdown propagation delay				1	μs
8	t _{pfivw} Low voltage falling output warning propagation delay				1	μs
9	t _f Fall time				1	μs

6.12 I²C Interface Switching Characteristics

 VBAT = VBATP = 6 V to 18 V, T_J = –40°C to +150°C (unless otherwise noted) (see [Figure 3](#))⁽¹⁾⁽²⁾

NO.	PARAMETER	TEST CONDITIONS	MIN	TYP	MAX	UNIT
SCL Serial clock timing						
1	f _{SCL} Serial clock frequency	Standard mode	0		100	kHz
		Fast mode	0		400	kHz
2	t _{HD, STA} Hold time for repeated start	Standard mode	4			μs
		Fast mode	0.6			μs
3	t _{LOW} Clock low pulse width	Standard mode	4.7			μs
		Fast mode	1.3			μs
4	t _{HIGH} Clock high pulse width	Standard mode	4			μs
		Fast mode	0.6			μs
5	t _{SU, STA} Setup time for repeated start	Standard mode	4.7			μs
		Fast mode	0.6			μs
6	t _{r, SCL} Clock rise time	Standard mode			1	μs
		Fast mode, C _{SCL} = 10 pF	21 ⁽³⁾		300	ns
		Fast mode, C _{SCL} = 400 pF	60		300	ns
7	t _{f, SCL} Clock fall time	Standard mode			0.3	μs
		Fast mode, C _{SCL} = 10 pF	21		300	ns
		Fast mode, C _{SCL} = 400 pF	60		300	ns
8	t _{SP, SCL} Clock input noise pulse				50	ns
SDA Serial communications data line						
9	t _{SU, DAT} Serial data setup time	Standard mode	250			ns
		Fast mode	100			ns
10	t _{r, SDA} Data rise time	Standard mode			1	μs
		Fast mode, C _{SDA} = 10 pF	21		300	ns
		Fast mode, C _{SDA} = 400 pF	60		300	ns
11	t _{f, SDA} Data fall time	Standard mode			300	ns
		Fast mode, C _{SDA} = 10 pF	21		300	ns
		Fast mode, C _{SDA} = 400 pF	60		300	ns
12	t _{SP, SDA} SDA input noise pulse				50	ns
13	t _{fo, SDA} SDA output pulse time	Standard mode			250	ns
		Fast mode, C _{SDA} = 10 pF	21		250	ns
		Fast mode, C _{SDA} = 400 pF	60		250	ns
14	t _{SU, STO} Stop bit setup time	Standard mode	4			μs
		Fast mode	0.6			μs
15	t _{BU} Bus free between stop and start bit	Standard mode	4.7			μs
		Fast mode	1.3			μs

 (1) Capacitance on serial interface pins SCL and SDA are 10 pF ≥ C_{SCL}, C_{SDA} ≥ 400 pF

(2) Parameters assured by worst case test program execution in fast mode.

 (3) The total load capacitance range for SCL and SDA for I²C specification

6.13 Switching Regulators Switching Characteristics

 VBAT = VBATP = 6 V to 18 V, T_J = –40°C to +150°C (unless otherwise noted)

NO.	PARAMETER	TEST CONDITIONS	MIN	TYP	MAX	UNIT
1	f _{SW} Nominal operating frequency		165			kHz
1	f _{SWTOL} Operating frequency tolerance		–15%		15%	
1	f _{SYN CH} Synch frequency range nominal		225		400	kHz
1	D _{SYN CH} Synch input duty ratio		40%		60%	

Switching Regulators Switching Characteristics (continued)

 $V_{BAT} = V_{BATP} = 6\text{ V to }18\text{ V}$, $T_J = -40^\circ\text{C to }+150^\circ\text{C}$ (unless otherwise noted)

NO.	PARAMETER	TEST CONDITIONS	MIN	TYP	MAX	UNIT
2	t_r Gate drive transition time, rising	$V_{GTx} = V_{GB} \times 6\text{ V}$, $C_{V_{GBx}} = 100\text{ nF}$			500 ⁽¹⁾	ns
3	t_f Gate drive transition time, falling	$V_{GTx} = V_{GB} \times 6\text{ V}$, $C_{V_{GBx}} = 100\text{ nF}$			100 ⁽¹⁾	ns
4	t_{DS} Synchronous switch on delay		20		100 ⁽²⁾	ns
5	t_{dt} Top switch on delay		20		100	ns
	t_{dc} Minimum on time		3.5% ⁽³⁾		98.2% ⁽⁴⁾	

(1) Switching times will vary for different external FET.

(2) Delay time is intended to guard against shoot-through losses and will be dependent upon the switch transition times. Measurements are done at either threshold values or 50% as shown below.

(3) $D_{on(min)} = (1.2\text{ V} \times (1 - t_{ol})) / V_{ov(max)}$ = $(1.2\text{ V} \times 0.95) / 33\text{ V}$.

(4) Min refresh time of 220 ns every five periods at 440 kHz.

6.14 Linear Regulator Switching Characteristics

 $V_{INLR} = 3\text{ V to }18\text{ V}$, $V_{BAT} = V_{BATP} = 6\text{ V to }18\text{ V}$, $T_J = -40^\circ\text{C to }+150^\circ\text{C}$ (unless otherwise noted) (see [Figure 5](#))

NO.	PARAMETER	TEST CONDITIONS	MIN	TYP	MAX	UNIT
1	t_{don} Turnon delay				15	μs
2	t_{doff} Turnoff delay				15	μs
3	t_{dovsd} Delay timer overvoltage shutdown				200	μs
4	t_{drovsd} Delay timer return from overvoltage shutdown				200	μs

6.15 High-Side Driver (HSD) Switching Characteristics

 $V_{BAT} = V_{BATP} = 6\text{ V to }18\text{ V}$, $HSD1EN = 1$, $T_J = -40^\circ\text{C to }+150^\circ\text{C}$ (unless otherwise noted) (see [Figure 6](#))

NO.	PARAMETER	TEST CONDITIONS	MIN	TYP	MAX	UNIT
1	t_{don} Turnon delay ⁽¹⁾		0		15	μs
2	t_{doff} Turnoff delay	$R_{HSD} = 180\ \Omega$	0		200	μs
3	t_r Rise time, 10% to 90%		25		75	μs
4	t_{dovsd} Delay timer overvoltage shutdown		0		200	μs
5	t_{drovsd} Delay timer return from overvoltage shutdown		0		200	μs

(1) Design information – Not tested

6.16 Timing and Switching Diagrams

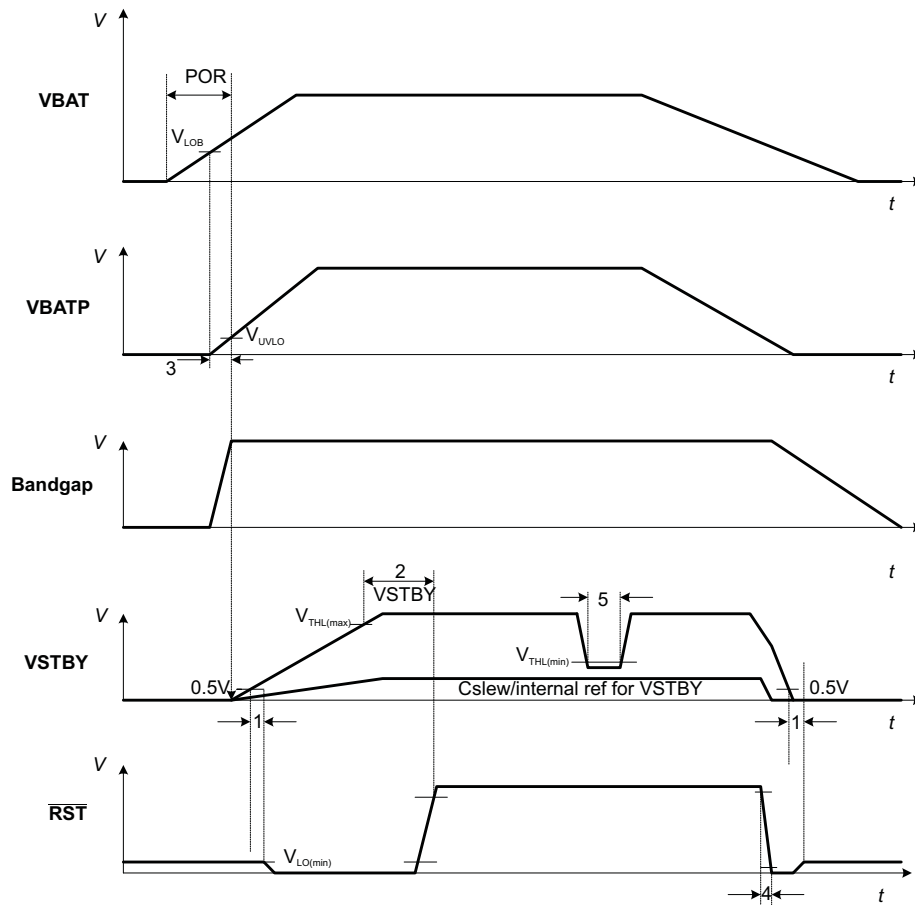

Figure 1. Input and Control Timing

Timing and Switching Diagrams (continued)

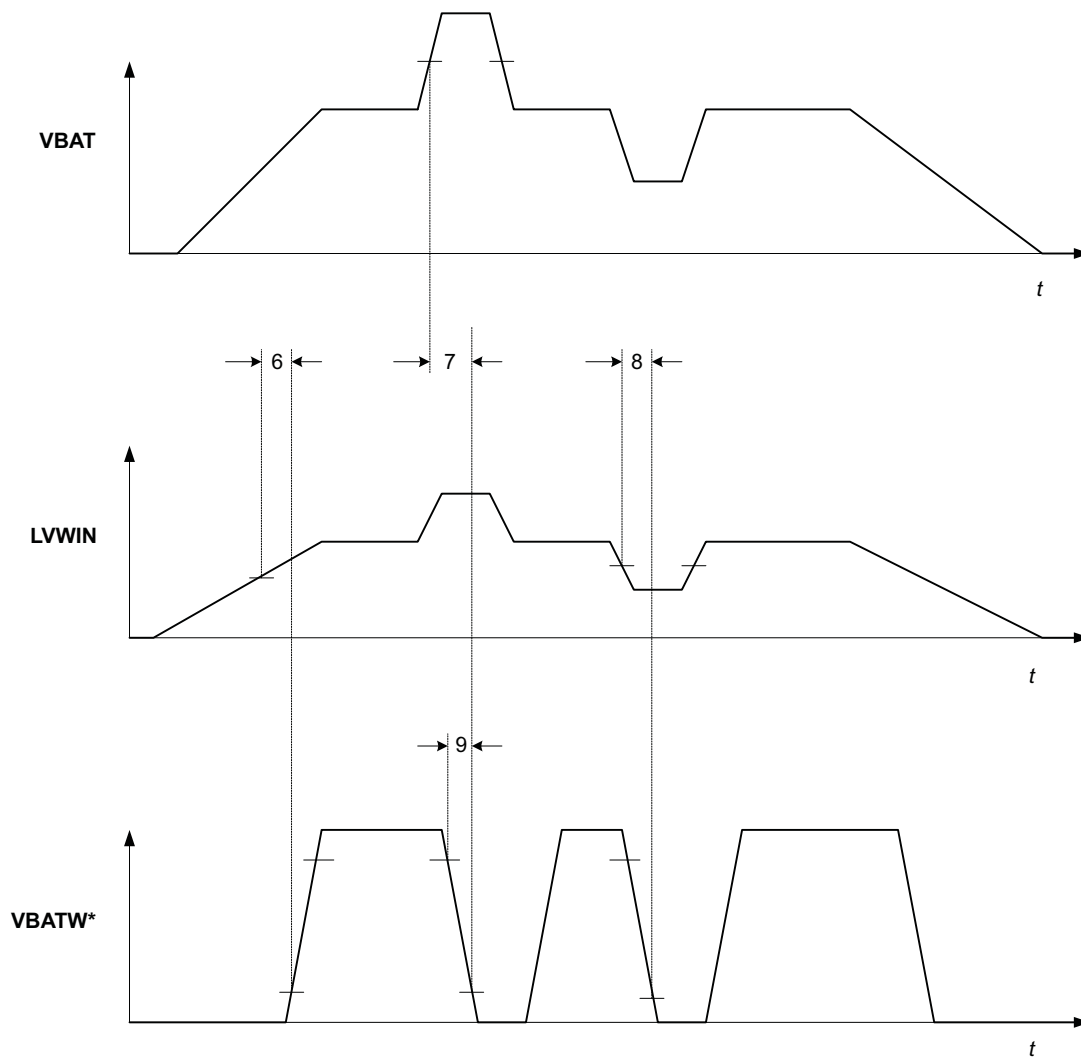

Figure 2. Input and Control Timing for $\overline{\text{VBATW}}$

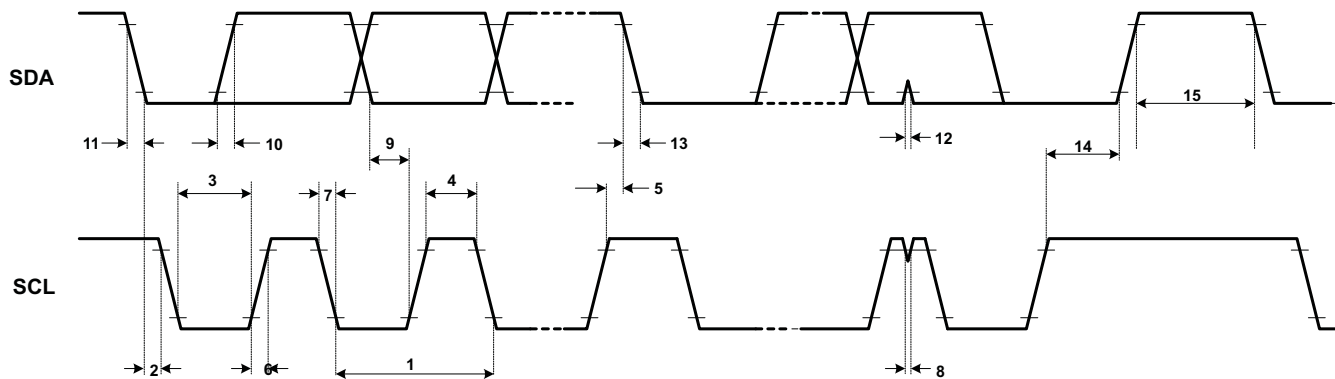

Figure 3. Serial Communication AC Timing (I²C Interface)

Timing and Switching Diagrams (continued)

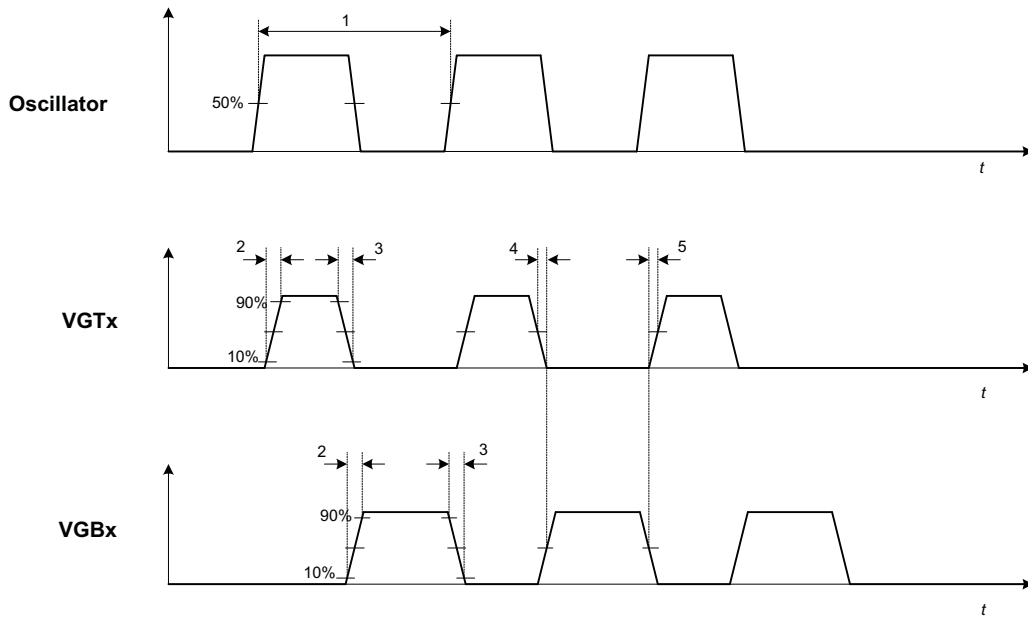

Figure 4. Switching Regulators Timing

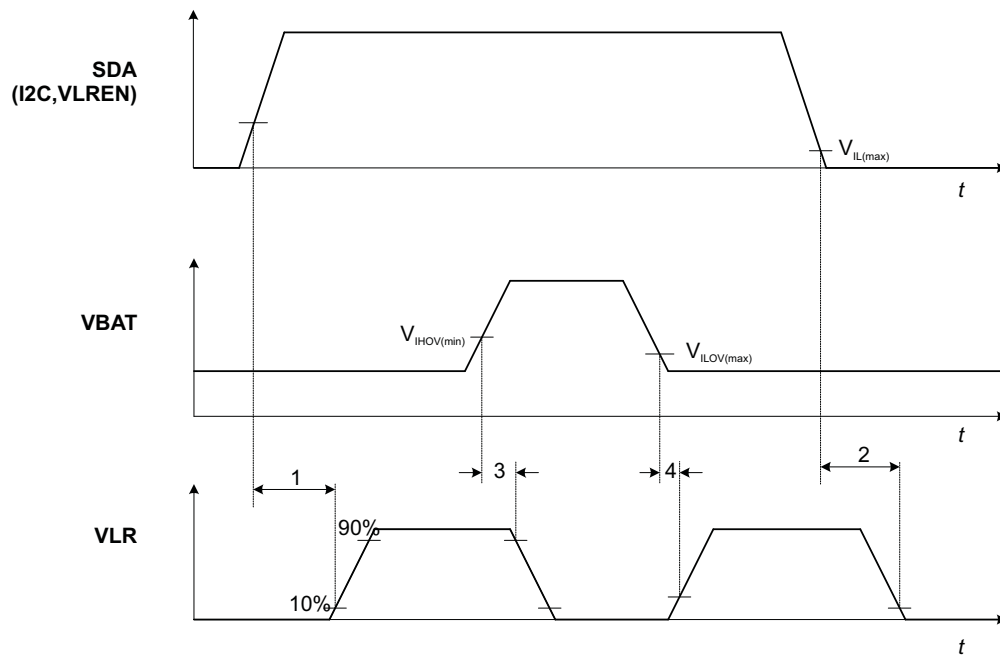

Figure 5. Linear Regulator Timing

Timing and Switching Diagrams (continued)

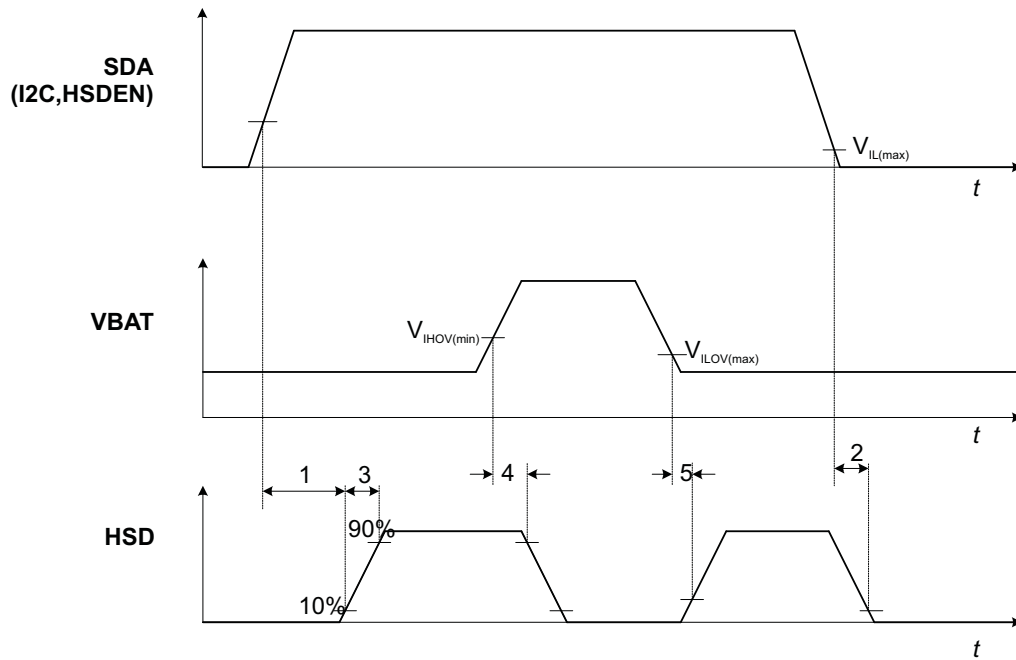

Figure 6. HSD Timing

6.17 Typical Characteristics

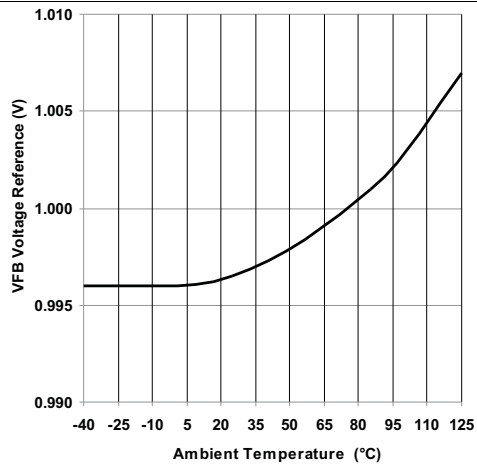

Figure 7. Feedback Reference vs Ambient Temperature

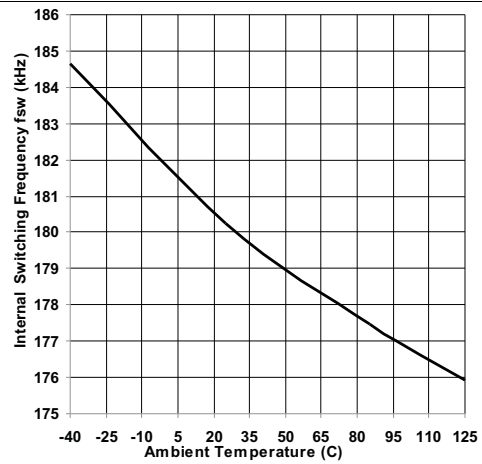

Figure 8. Internal Fixed Switching Frequency vs Ambient Temperature

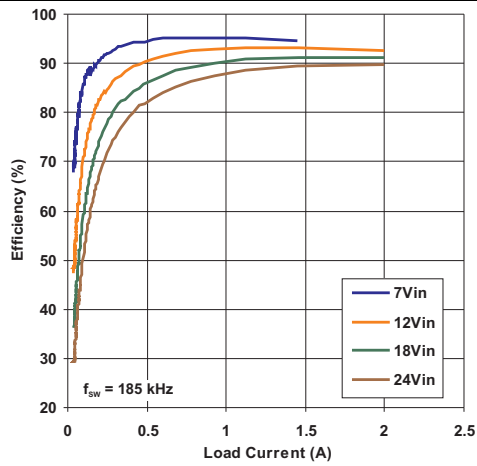

Figure 9. Efficiency vs Load Current

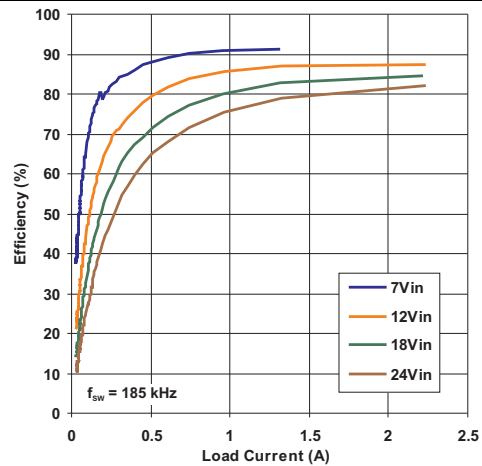

Figure 10. Efficiency vs Load Current

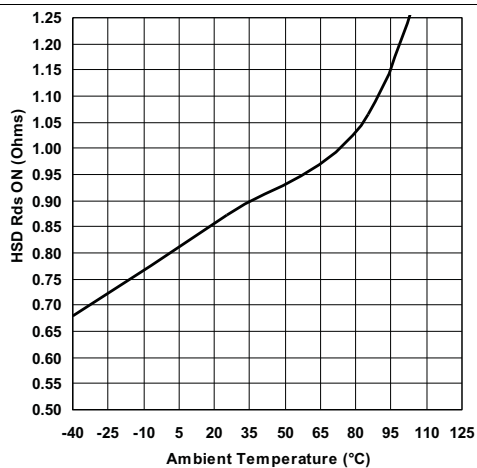

Figure 11. HSD RDS ON Resistance vs Ambient Temperature

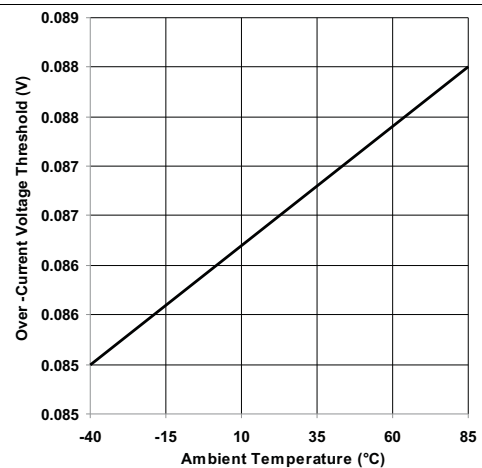

Figure 12. Overcurrent Voltage Threshold vs Ambient Temperature

Typical Characteristics (continued)

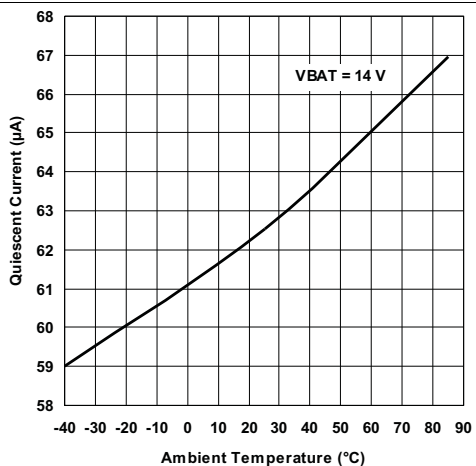

Figure 13. Quiescent Current vs Ambient Temperature

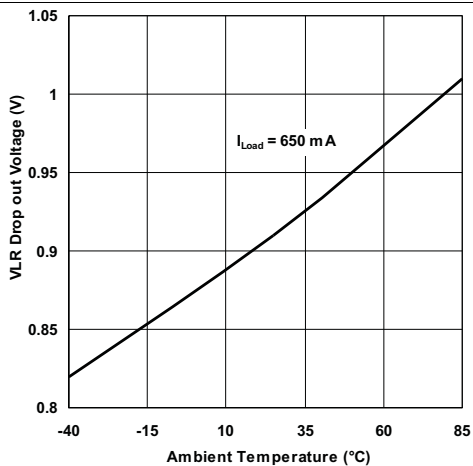

Figure 14. VLR Dropout Voltage vs Ambient Temperature

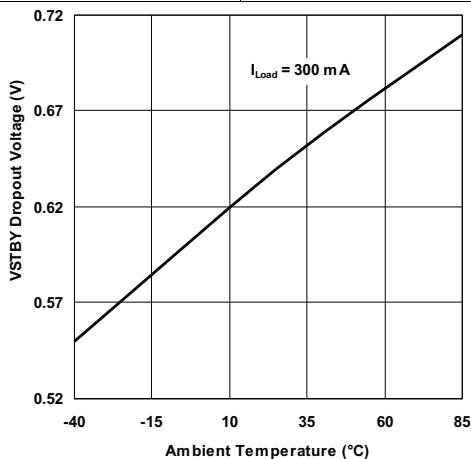

Figure 15. VSTBY Dropout Voltage vs Ambient Temperature

7 Detailed Description

7.1 Overview

The TPS43331-Q1 is a combination of two switched mode synchronous step down controllers and two linearly regulated power supplies. There is also a protected high side output, controlled by a discrete input to switch auxiliary input power to other devices in the system. The standby regulator VSTBY is enabled once the input power from the protected terminal of the battery supply is available to the device. The standby regulator consumes less than 75 μA with less than 100 μA of load current on the regulated output terminal (VSTBY). In this condition the device is operating in the low power mode and current consumption from the input voltage source is minimized. The standby regulator on initial power up has a soft start function (CSLEW); the voltage ramp on the CSLEW is used to control the output voltage ramp rate of the standby regulator.

The second linearly regulated supply will be controlled through the serial communications. A digital bit assigned in a register controls if the VLR output is enabled (bit = 1) or disabled (bit = 0). This regulator is powered from either protected battery input or regulated voltage source. Both linearly regulated supplies can be programmed to a specified output voltage range based on feedback threshold setting on their respective sense terminals (VSTBYS and VLRS).

The two switch-mode synchronous step down controllers are configured to drive external NMOS power switches, and control the energy in the inductor by limiting the current using a resistor current sense feedback. The output voltage is regulated using external resistor feedback network. The regulated output voltage can be programmed to a specified range using different feedback thresholds at the VFB(x) terminal. The switch mode step down controller channel 1 is enabled when the active mode terminal EN is set high (logic 1). The second switch mode controller channel 2 is activated using the serial communications interface. Both switch mode configuration have dead time implementation to prevent simultaneous conduction during the switching phase. This is achieved by monitoring the voltage on the phase node to control gate drive sequencing. To minimize ripple current on the input line the two buck regulators are switched 180° out of phase. In addition, the SYNCH pin can be used to alter the switching frequency of both regulators and synchronize it to an external clock operating between 150 kHz and 400 kHz. Although the switching is now synchronous with the external clock, both regulators always operate 180° out of phase with respect to each other. During initial power up the switch mode regulator has a soft start function based on the internal oscillator and independent of the external clock signal on the synchronization input (SYNCH).

The high side switch output is powered from battery and has internal reverse blocking to prevent conduction when the power input line is bias negative with respect to high side driver output terminal. This output is current limited in the event of a short to ground condition. The output is controlled through serial communications, a single bit setting with the default being output OFF state.

The voltage supervisor circuitry monitors the standby voltage output and activates the reset line (pulls $\overline{\text{RST}}$ low) if the regulated output voltage is below low voltage threshold. There is a power good delay timer function (PGDLY) which allows the output voltage to stabilize before the $\overline{\text{RST}}$ line is deasserted. This delay time can be programmed externally using a capacitor. The second voltage supervisor monitors the scaled value of the input voltage source sensed on the LVWIN terminal. If the voltage sensed at this node is below the internal threshold setting, the voltage warning output terminal ($\overline{\text{VBATW}}$) is pulled low. Alternatively if the VBAT input is above an overvoltage set point (27 V to 31 V), the outputs are disabled and voltage warning output terminal ($\overline{\text{VBATW}}$) is pulled low.

The serial communications is using the inter-IC communications (I²C) interface bus. The maximum frequency of operation is 400-kbaud, and a chip identifier terminal (I2CID) sets the address for communications.

Thermal sensing and protection is implemented for both the linear regulators and the high side driver outputs. Thermal shutdown on any one output will NOT directly disable any other output circuitry.

Overview (continued)

1.
7.2 Functional Block Diagram

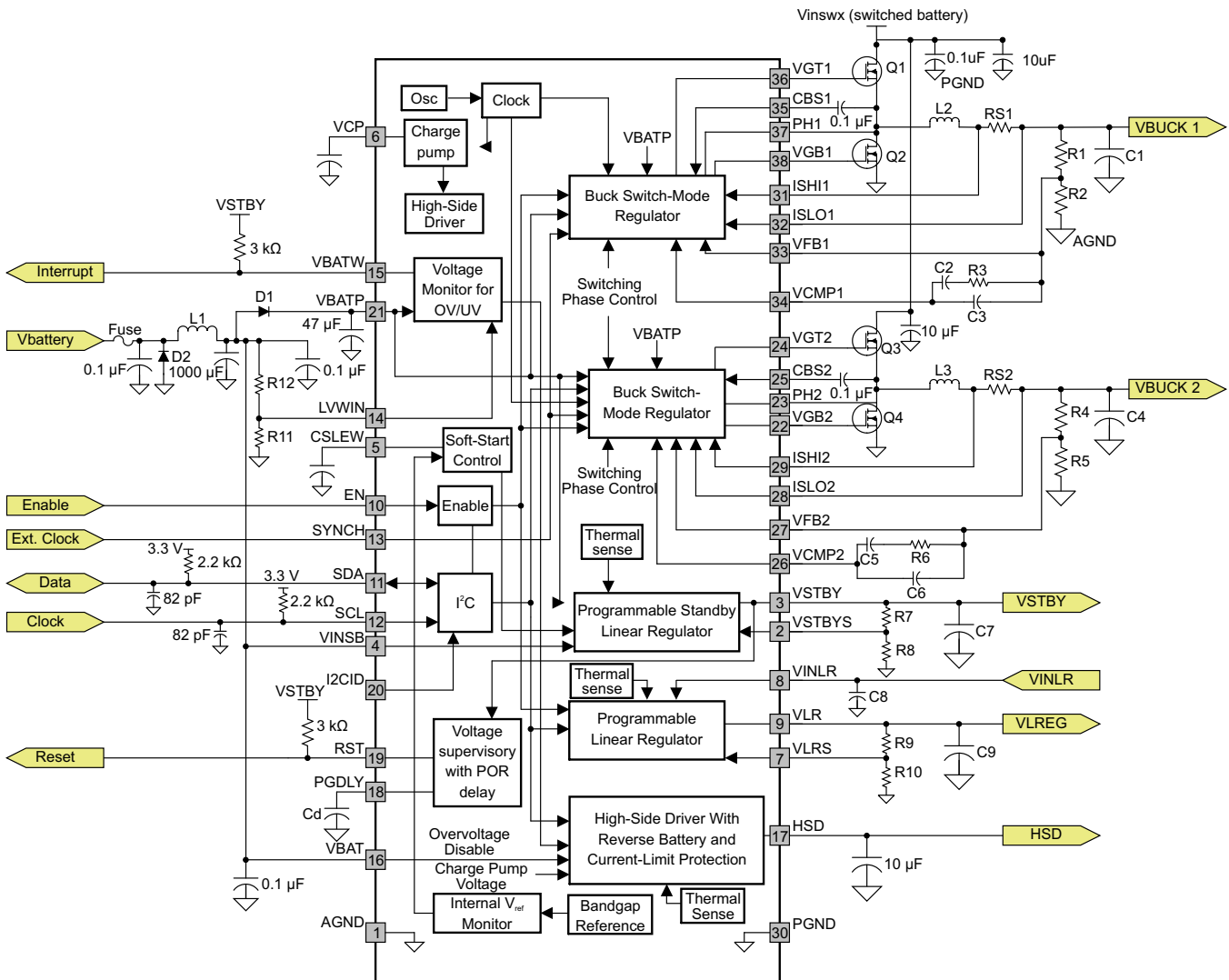

Copyright © 2017, Texas Instruments Incorporated

Figure 16. Typical Application Schematic

7.3 Feature Description

7.3.1 Unregulated Battery Input Voltage (VBAT)

This input terminal will have an external input filter and voltage suppression above 40 V for protection. The input is used to provide the operating voltage for the high side driver output, and used for sensing over voltage condition in the system. The over voltage detection circuitry has hysteresis for noise rejection.

7.3.2 Protected Unregulated Battery Input Voltage (VBATP)

This terminal provides the power source for internal circuitry to bias band-gap reference, oscillator and other circuitry in the device. The voltage on this terminal is used to sense for system undervoltage condition.

Feature Description (continued)

7.3.3 Low-Voltage Warning Input (LVWIN)

This input is used to detect low voltage condition. The input voltage source is scaled using external resistor network (programmable) to set the threshold for detection of low voltage condition. Once the input voltage is below the set threshold the low voltage warning output terminal is pulled low ($\overline{\text{VBATW}}$).

7.3.4 Voltage Warning Output ($\overline{\text{VBATW}}$)

This is an open drain output which is pulled up to supply with an external resistor. This output is asserted low when either of the following conditions is satisfied:

- Detection of low-voltage condition
- Detection of overvoltage condition

If the fault condition is removed the $\overline{\text{VBATW}}$ output is deasserted (output goes high).

7.3.5 Low-Voltage Reset ($\overline{\text{RST}}$)

This output indicates if there is a low voltage on the standby regulator output (VSTBY). The output is deasserted once the standby regulator achieves proper regulation and after the power delay timer has expired. This low voltage reset circuitry is functional for voltages above 0.5 V on the standby regulator output terminal. Additionally the low voltage reset output will remain low if the standby regulator input voltage is in the undervoltage lockout mode. If the PGDLY and VSTBYS pins are both high, the nRST pin is high. The VSTBYS voltage must be higher than 0.93 V (typical) and the nRST pin is pulled low 10 μs (typical) after the VSTBYS pin goes low.

7.3.6 Power-Good Delay Timer Input (PGDLY)

The capacitor on this terminal programs power good delay timer function. A current source on this pin charges an external capacitor once the standby regulator achieves proper regulation. Once the voltage on the capacitor exceeds the internal threshold the internal comparator will deassert the reset output line. The external capacitor is discharged (reset) once the RST output is deasserted, and so any subsequent power up sequence will start from zero time for the power good delay. The power good delay is not initiated as a result of external device asserting the reset output terminal.

7.3.7 Active Mode Enable Input (EN)

This input pin commands different modes of operation. When asserted low the device will enter low quiescent standby mode, with only the standby regulator ON. Once the input is asserted high the device is in active mode and regulator output control is achieved by discrete inputs and serial communications. The input is TTL-compatible with hysteresis for noise rejection. There is an internal pull down to ensure a default state of standby mode.

7.3.8 Slew Rate Control Capacitor Input (CSLEW)

This pin provides the soft-start function for an internal reference used by the standby linear voltage regulator. An internal current source will charge an external capacitor to produce a linear voltage ramp at start up for the internal reference. This will be used to limit the slew rate of the output voltage of the standby regulator. An internal low side switch is used to discharge the capacitor in accordance with the operating mode requirements for slew rate control.

The soft start time must be greater than $dt_{ss} > 2\pi (LC)^{1/2}$.

$$C = dt \times I / dv$$

where

- $dv = 1.2 \text{ V}$
- $I = 1.6\text{- to } 2.4\text{-}\mu\text{A range}$
- $dt > 2\pi (LC)^{1/2}$

(1)

Feature Description (continued)

7.3.9 Charge Pump Capacitor Input (VCP)

This pin has an external capacitor to provide storage for an internal charge pump.

This charge pump is activated at supply voltages less than approximately 9 V to appropriately supply the high-side driver. When active, the quiescent current is increased.

7.3.10 Power Ground (PGND)

This pin is the power ground reference for the device. All switching nodes are referenced to this ground.

7.3.11 Analog Ground Reference (AGND)

This pin is reference ground for ALL non-power and non-switch-mode related ground termination inside the device.

7.3.12 Inter-IC Communications Interface (I2CID)

The serial communications interface is a 7-bit address for controlling the switch mode controller 2 (VBUCK 2), linear regulator (VLR) and high side driver output (HSD). There are two lines SCL and SDA to control the communications between the master and the slave. An I2CID terminal is used to address the IC in a system where multiple IC's may be implemented. The SDA terminal has an internal FET switch to pull the SDA low as an acknowledgment signal back to the main controller. An active high allows access to the register.

7.3.13 Clock Input (SCL)

This pin is an input pin for a clock signal input from the master control. The clock signal is used to synchronize the data communications between the master device and the slave (TPS43331-Q1). The input signal will be TTL-compatible with hysteresis for noise rejection.

7.3.14 Data Line (SDA)

The pin is a data line communications between the master and slave device. The input signal is TTL-compatible with hysteresis for noise rejection. An internal pull down driver will provide an acknowledgment signal back to the master controller.

7.3.15 Interface Chip Identifier (I2CID)

The pin is used as a chip identification input for the I²C interface between the master and the slave device. The input signal is TTL-compatible with hysteresis for noise rejection. The state of the input signal is reflected in the I²C chip address byte 0. The value of the signal on this terminal is latched on a POR condition. A low leakage internal pull-down is implemented to ensure the default state is zero.

The device requires a three-byte access from the microcontroller (Chip address, Register address and data).

7.3.16 Switch Mode Regulators

There are two switch-mode controllers when configured with external power switches form the buck (step-down) regulators. One switch-mode regulator is controlled by an enable input control (EN) and the second is controlled by a bit using the serial communications interface.

Short-circuit detection is achieved by current sensed through an external sense resistor in series with the inductor. The current limit is applied on a cycle-by cycle basis. Once overcurrent is detected the output is disabled for the remainder of the cycle, and is enabled on the next clock edge.

7.3.17 Upper FET Gate Drive Outputs (VGT1 and VGT2)

These outputs are the gate drive signals for the external high side FETs for each switch-mode controller.

The output voltage is clamped to prevent excessive gate drive voltage to the external MOS devices. These outputs are a push-pull configuration and are current limited for charging a capacitive load.

Feature Description (continued)

7.3.18 Lower FET Gate Driver Outputs (VGB1 and VGB2)

These outputs are the gate drive signals for the external low side FETs for each switch-mode controller. The switching signal is 180 degrees out of phase with the upper gate drive signals for each controller. The lower gate drive controls the FET for synchronous switching. These output signals are clamped to prevent excessive gate voltage to the external MOS devices. These outputs are a push-pull configuration and are current limited for charging a capacitive load.

7.3.19 Bootstrap Capacitor Input (CBS1 and CBS2)

These pins are the bootstrap capacitor inputs for switcher 1 and switcher 2 respectively. These capacitors act as the voltage supply for the upper gate drive circuitry. The capacitors are re-charged on every low side synchronous switching action. In the case of 100% duty cycle for the upper FET, the device will automatically reduce the duty cycle to approximately 95% on every fifth cycle to allow these capacitors to re-charge.

7.3.20 Phase Reference for High-Side Bootstrap Supply (PH1 and PH2)

These pins provide a floating voltage reference for the high-side FET gate drive circuitry for switcher 1 and switcher 2 respectively. These nodes are used to monitor the status of the upper external FETs, and allow switching of the lower external FETs without shorting the supply.

7.3.21 Current Sense High-Side (ISH1 and ISH2)

These are the high-side current sense resistor node inputs for switcher 1 and switcher 2 respectively. The common mode range of the combined high-side and low-side current sense inputs supports the entire output voltage range.

7.3.22 Current Sense Low-Side (ISLO1 and ISLO2)

These are the low-side current sense resistor node inputs for switcher 1 and switcher 2 respectively. The common mode range of the combined high-side and low-side current sense inputs supports the entire output voltage range.

7.3.23 Regulated Output Sense Voltage Feedback (VFB1 and VFB2)

These are the input pins for the voltage output feedback signals for switcher 1 and switcher 2 respectively. The external resistor network setting on these pins programs the desired regulated output voltages for each switch-mode converter.

7.3.24 Feedback Compensation Input (VCMP1 and VCMP2)

These are the input pins for the converter compensation feedback for switcher 1 and switcher 2 respectively.

7.3.25 Synchronization Input (SYNCH)

This is an input pin for feeding an external clock to synchronize the switching frequency of both switch-mode regulators. The IC will detect a small number of edges (2 to 5) prior to recognizing a valid external clock input signal and synchronizing the internal operation with an external clock input. The regulator operates with an external input clock signal until a low voltage reset or a command to go into a sleep mode.

7.3.26 Standby Linear Regulator Input (VINSB)

This is the input pin for the operating voltage of the standby regulator. The voltage source for the standby regulator requires an external blocking diode in the module for reverse supply conditions. This input pin requires the necessary filtering and protection against positive and negative transients to prevent damage to the IC (see [Figure 16](#)).

Feature Description (continued)

7.3.27 Standby Regulator Output (VSTBY)

This is the regulated output of the standby regulator, and derives the voltage source from the VINSB terminal. The regulator has an internal linear current limit for protection against shorts to ground. The output voltage will recover to the specified range once the fault condition is removed. This output remains within the tolerance of the specification during positive transient events on the input. An under-shoot condition during any load transient event will not assert a reset condition on the $\overline{\text{RST}}$ output, proving the load transient is within the specified range.

Once the regulator drops-out due to low input voltage on VINSB, the output tracks the input voltage minus the saturation voltage of the pass device. The device will enter thermal shut down if the local die temperature exceeds the thermal shut-down threshold. The thermal shut-down has hysteresis such that the output enables once the local die temperature falls below the disable threshold. If the output falls below the specified low voltage reset, the IC will notify this condition by asserting the rest line $\overline{\text{RST}}$ low.

7.3.28 Standby Regulator Sense Voltage (VSTBYS)

This pin is used to program the regulated output voltage to a range specified in the parametric table. An external resistor network is used to ratio the output voltage and fed back into the VSTBYS pin.

7.3.29 Switched Linear Regulator Input (VINLR)

This is the input pin for the operating voltage of the switched linear regulator. The voltage source for this regulator requires an external blocking diode in the module for reverse supply conditions. This input pin requires the necessary filtering and protection against positive and negative transients to prevent damage to the IC (see [Figure 16](#)).

7.3.30 Switched Linear Regulator Output (VLR)

This is the regulated output of the switched linear regulator, and derives the voltage source from the VINLR terminal. The regulator has an internal linear current limit for protection against shorts to ground. The output voltage will recover to the specified range, once the fault condition is removed. This output remains within the tolerance of the specification during load transient event on the output line. The output is disabled in the event VBAT exceeding the overvoltage shut-down threshold VOVS. The output will be enabled once the VBAT input voltage falls below the internal set threshold (with hysteresis).

Once the regulator drops-out due to low input voltage on VINLR, the output tracks the input voltage minus the saturation voltage of the pass device. The device will enter thermal shut down if the local die temperature exceeds the thermal shut-down threshold. The thermal shut-down has hysteresis such that the output enables once the local die temperature falls below the disable threshold.

7.3.31 Switched Linear Regulator Sense Voltage (VLRS)

This pin is used to program the regulated output voltage to a range specified in the parametric table. An external resistor network is used to ratio the output voltage and fed back into the VLRS pin.

7.3.32 High-Side Driver Output (HSD)

This pin is the output of the high side driver (switched input voltage). The output is enabled through a bit in the I²C data register. If the voltage on the VBAT supply exceed the overvoltage shutdown threshold VOVS this output is disabled. Upon return from the fault condition the output recovers to the state set by the enable bit (HSDEN) in I²C data register without any intervention from the system. The output is stable during any soft-start conditions or specified load transients. This output is protected against:

- Short to module supply
- Short to module ground
- Short through the load to -1 V
- Unpowered short to module supply
- Reverse supply (-13 V)

The output has short circuit protection with a linear current limit and thermal shutdown with hysteresis.

Feature Description (continued)

If the local die temperature exceeds the thermal shutdown detection threshold this output is disabled. This output is enabled once the local die temperature falls below the detection threshold with hysteresis providing the HSDEN bit is set.

The invoking of thermal shut down on this output does not directly affect any other outputs or circuitry in the IC. The operation of the switch is not affected during the re-circulation of an inductive load providing the negative voltage applied to this pin is within the specified limits

7.4 Device Functional Modes

7.4.1 Operating Mode Definition

Figure 17 shows the operating modes of the TPS43331-Q1.

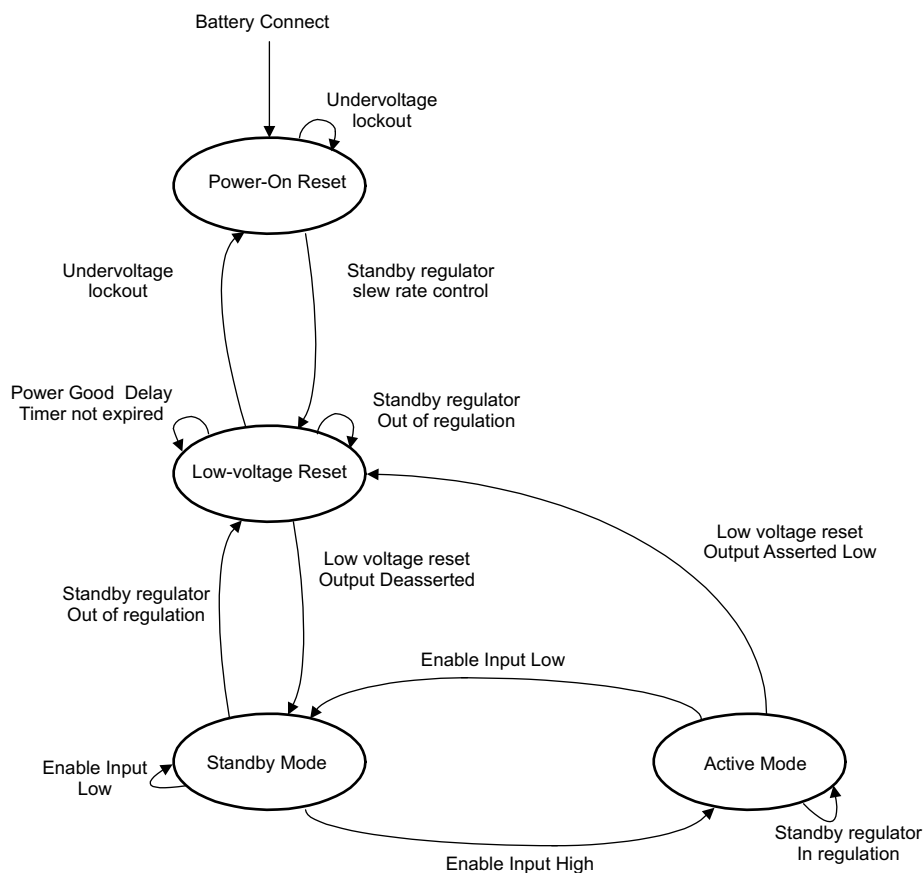

Figure 17. Operating Modes

7.5 Programming

7.5.1 Register Definition for I²C

7.5.1.1 Chip Address Byte

The IC supports two addresses by using bit 4 of the chip address byte and the I2CID input. The state of the I2CID input pin is read into bit 3 of the chip address byte (indicated by X in the frame above).

The valid chip addresses for writing to this IC are \$0001000 (0x08) and \$0001100 (0x0C), since the LSB of the chip address byte is a read/write bit, these two addresses translate into hex values of 0x10 and 0x18 respectively.

Frame format requires two-byte access from the master controller.

- The first byte contains the address information
- The second byte contains the data information

Table 1. Frame Format

CHIP ADDRESS BYTE 0										REGISTER ADDRESS										DATA BYTE 0									
S	0	0	0	1	X	0	0	0	0	A	0	0	0	0	0	0	0	1	A	7	6	5	4	3	2	1	0	A	P
	MSB								LSB																				

The data format/transfer will be the following order:

1. MSB first to LSB last; Bit 7 of each byte is the MSB. Bit 0 of each byte is the LSB.
2. Bit 0 (LSB) in the address byte defines the read/write bit; a value of 0 indicates a data write.
3. The bit marked X in the address byte indicates the state of the I2CID input.

Transmission format:

1. The data transfer begins with a start signal (S), where the SDA transitions from high to low while SCL is high (see [Figure 18](#)).
2. After 8 bits are transmitted and detected the IC (TPS43331-Q1) will send an acknowledge pulse (A) to the master.
3. After each successive writes of 8 bits, the IC sends an acknowledge pulse to the master.
4. The message communications is completed (stop condition P) when SDA transitions from low to high while SCL is high.

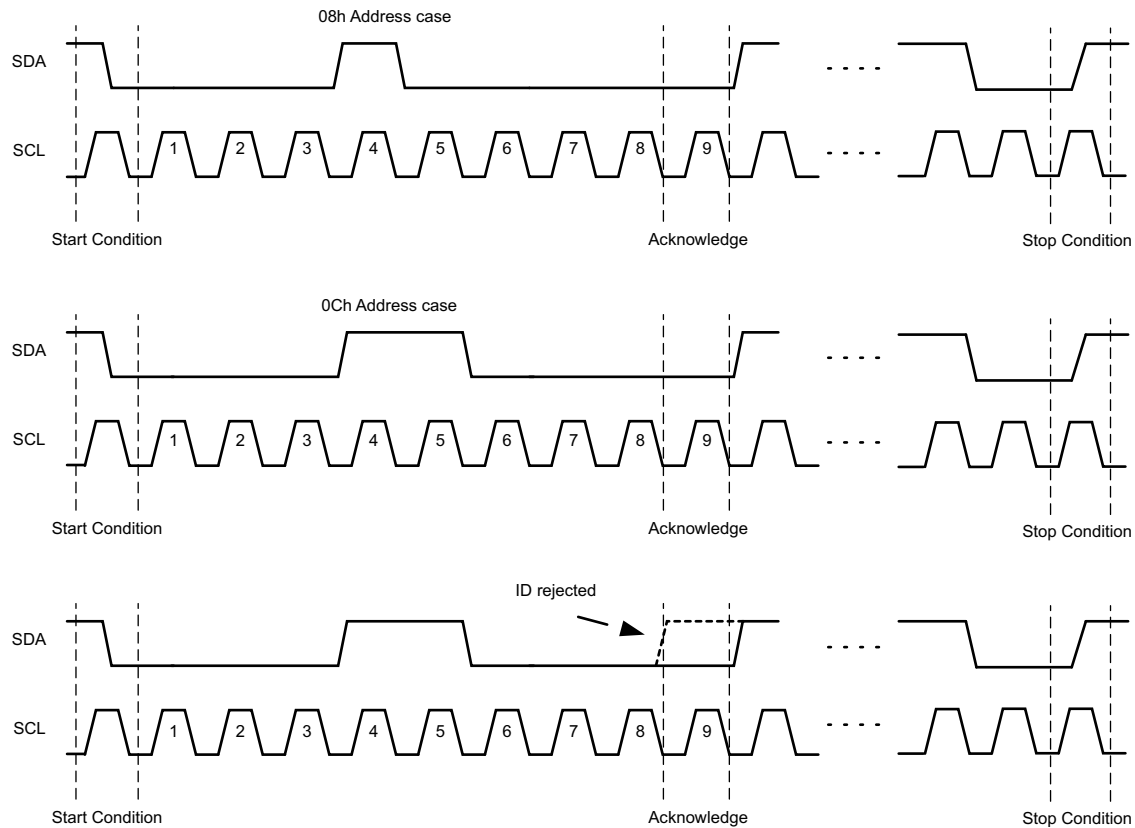

- (1) Bit 8 is used for read or writer options, with:
 Bit 8 = 1 is read
 Bit 8 = 0 is write

Figure 18. I²C Communications

If a transfer is interrupted by a stop condition, the partial byte transmission shall not be latched. Only the prior messages transmitted and acknowledged are latched.

7.6 Register Map

7.6.1 Data Register

Figure 19. Data Register Format

7	6	5	4	3	2	1	0
X	X	X	X	X	SW2EN	LREN	HSDEN
R/W-0	R/W-0	R/W-0	R/W-0	R/W-0	R/W-0	R/W-0	R/W-0

LEGEND: R/W = Read/Write; R = Read only; –n = value after reset

Table 2. Data Register Field Descriptions

BIT	FIELD	TYPE	RESET	DESCRIPTION
7–3	X	R/W	00000	X
2	SW2EN	R/W	0	SW2EN default state = 0, switcher 2 is OFF (disabled) SW2EN = 1, switcher 2 ON (enabled)
1	LREN	R/W	0	LREN default state = 0, the switched linear regulator (VLR) is OFF LREN = 1, the switched linear regulator (VLR) is ON
0	HSDEN	R/W	0	HSDEN default state = 0, the high side switch is OFF HSDEN = 1, the high side switch is ON

8 Application and Implementation

NOTE

Information in the following applications sections is not part of the TI component specification, and TI does not warrant its accuracy or completeness. TI's customers are responsible for determining suitability of components for their purposes. Customers should validate and test their design implementation to confirm system functionality.

8.1 Application Information

The TPS43331-Q1 is a combination of two switched-mode, synchronous step-down controllers and two linearly-regulated power supplies. These devices are configured to drive external NMOS power switches and control the energy in the inductor by limiting the current using a resistor current sense feedback. The output voltage is regulated using an external resistor feedback network. The regulated output voltage can be programmed to a specified range using different feedback thresholds at the VFB(x) terminal. To minimize ripple current on the input line, the two buck regulators are switched 180° out of phase.

The protected high-side output is controlled by a discrete input to switch auxiliary input power to other devices in the system. The standby regulator VSTBY is enabled when the input power from the protected terminal of the battery supply is available to the device. The standby regulator consumes less than 75 μA , with less than 100 μA of load current on the regulated output terminal (VSTBY).

8.2 Typical Application

The calculations from the [Buck Regulators](#) section result in the schematic shown in [Figure 20](#).

The design requirements for the switching regulator design in [Figure 20](#) are listed in [Table 3](#).

Assume Type III Compensation network for each buck regulator.

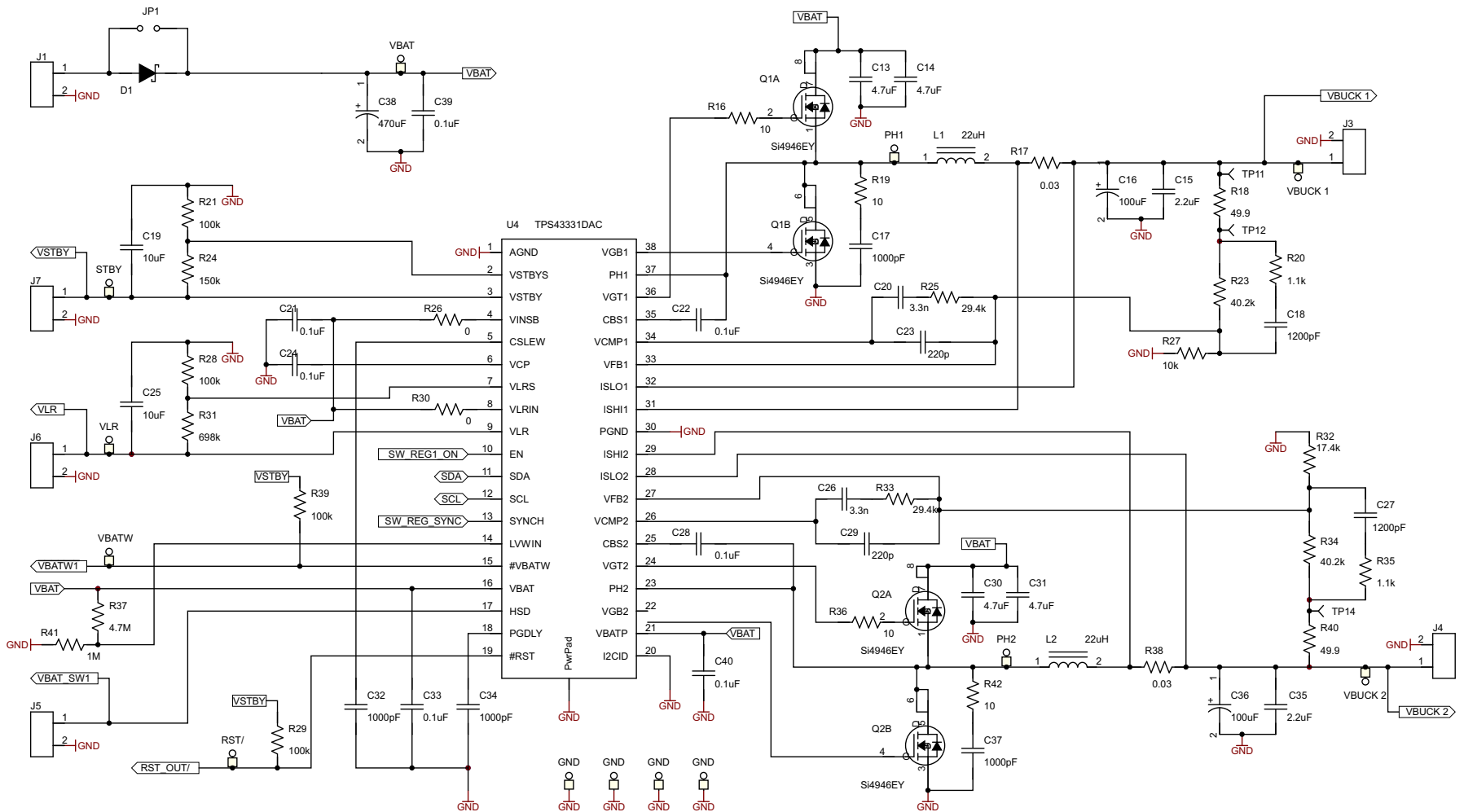

Copyright © 2017, Texas Instruments Incorporated

Figure 20. Design Circuit Schematic

8.2.1 Design Requirements

For this design example, use the parameters listed in [Table 3](#).

Table 3. Design Requirements

PARAMETER	VALUE
Input voltage	8 V to 26 V (14 V typ)
Output voltage buck regulator 1 – V _{BUCK} 1	Min = 4.75 V, Max = 5.25 V
Output voltage buck regulator 2 – V _{BUCK} 2	Min = 3.135 V, Max = 3.465 V
Converter switching frequency, f _{SW}	250 kHz
Maximum output current on buck regulator 1 – I _O	2 A
Maximum output current on buck regulator 2 – I _O	1.5 A
Maximum ripple current I _{ripple}	0.2 × I _O

8.2.2 Detailed Design Procedure

8.2.2.1 Type II Compensation

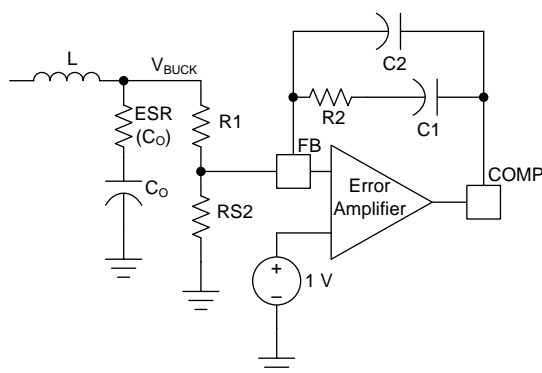

Figure 21. Type II Compensation

The LC output filter gives a *Double Pole* which has a -180° phase shift.

$$f_{LC} = \frac{1}{2\pi\sqrt{LC_0}} \text{ (Hertz)} \quad (2)$$

The ESR of the output capacitor, C_0 , gives a zero that has a 90° phase shift.

$$f_{ESR} = \frac{1}{2\pi \times C_0 \times ESR_{C_0}} \text{ (Hertz)} \quad (3)$$

The values of R1 and RS2 are chosen based on the desired V_{BUCK} .

$$V_{BUCK} = V_{ref} \times \frac{R1 + RS2}{RS2} \text{ (Volt)}$$

where

- $V_{ref} = 1 \text{ V}$ (4)

Use the following equations to select the resistor values:

Select $R_{S2} = 10 \text{ k}\Omega$

$$R1 = \frac{R_{S2}(V_{BUCK} - V_{ref})}{V_{ref}} \quad (5)$$

$$R1 = \frac{10000(V_{BUCK} - 1)}{1} \quad (6)$$

$$R2 = \frac{f_c \times V_{ramp} \times R1}{V_{BAT} \times f_{LC}}$$

where

- $V_{ramp} = 1.8 \text{ V}$, V_{BAT} = typical input operating voltage
- $f_c = f_{SW} \times 0.1$ (the cutoff frequency, when the gain is 1 is called the unity gain frequency)

The f_c is typically 1/5 to 1/10 of the switching frequency.

Use Equation 8 to calculate the PWM modulator gain (K).

$$K = \frac{V_{BAT}}{V_{ramp}} \quad (8)$$

Use Equation 9 to calculate the amplifier gain (A_v).

$$A_v = \frac{R2}{R1} \quad (9)$$

$$f_z = \frac{f_c}{K} \text{ (Hertz)} \quad (10)$$

$$f_p = f_c \times K \text{ (Hertz)} \quad (11)$$

$$C1 = \frac{10}{2\pi \times R2 \times f_{LC}} \quad (12)$$

$$C2 = \frac{C1}{(\pi \times R2 \times C1 \times f_{SW}) - 1} \quad (13)$$

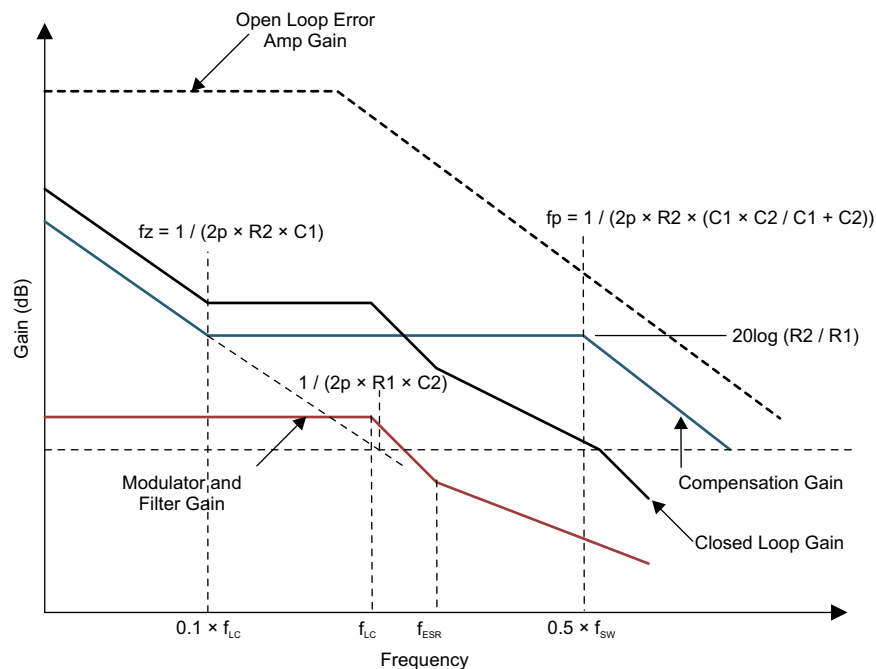
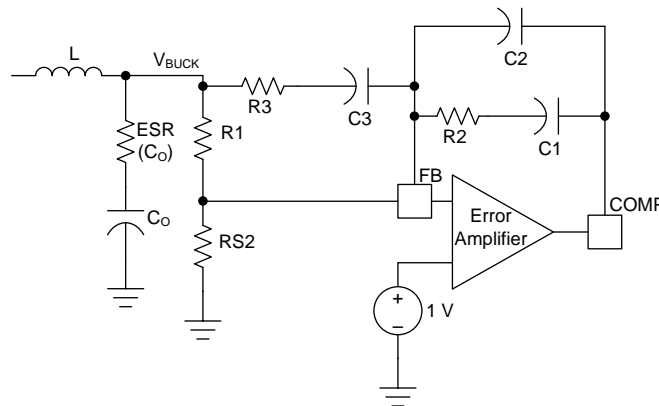

Figure 22. Type II Bode Plots

8.2.2.2 Type III Compensation

Figure 23. Type III Compensation

$f_c = f_{SW} \times 0.1$ (the cutoff frequency when the gain is 1 is called the unity gain frequency).

The f_c is typically 1/5 to 1/10 of the switching frequency double pole frequency response due to the LC output filter.

The LC output filter gives a *Double Pole* which has a -180° phase shift.

$$f_{LC} = \frac{1}{2\pi\sqrt{LC_O}} \text{ (Hertz)} \quad (14)$$

The ESR of the output capacitor, C_O , gives a zero that has a 90° phase shift.

$$f_{ESR} = \frac{1}{2\pi \times C_O \times ESR_{C_O}} \text{ (Hertz)} \quad (15)$$

$$V_{BUCK} = \frac{V_{ref} \times (R1 + RS2)}{RS2} \text{ (Volt)}$$

where

- $V_{ref} = 1 \text{ V}$ (16)

Use [Equation 17](#) to calculate the PWM modulator gain (K).

$$K = \frac{V_{BAT}}{V_{ramp}}$$

where

- $V_{ramp} = 1.8 \text{ V}$
- $V_{BAT} = \text{typical input operating voltage}$ (17)

Use [Equation 18](#) to calculate the amplifier gain (A_v).

$$A_v = \frac{R2 \times (R1 + R3)}{R1 \times R3} \quad (18)$$

$$f_{P1} = \frac{C1 + C2}{2\pi \times R2 \times (C1 \times C2)} \text{ (Hertz)} \quad (19)$$

$$f_{P2} = \frac{1}{2\pi \times R3 \times C3} \text{ (Hertz)} \quad (20)$$

$$f_{Z1} = \frac{1}{2\pi \times R2 \times C1} \text{ (Hertz)} \quad (21)$$

$$f_{Z2} = \frac{1}{2\pi \times (R1 + R3) \times C3} \text{ (Hertz)} \quad (22)$$

Use the following guidelines for compensation components:

Make the two zeroes close to the double pole (LC); for example, $f_{z1} \approx f_{z2} \approx 1 / 2\pi \times (LC_O)^{1/2}$.

1. Make the first zero below the filter double pole (approximately 50% to 75% of f_{LC}).
2. Make the second zero at filter double pole (f_{LC}).

Make the two poles above the cross-over frequency f_c .

1. Make the first pole at the ESR frequency (f_{ESR}).
2. Make the second pole at 0.5 the switching frequency ($0.5 \times f_{SW}$).

Use the following equations to select the resistor values:

Select $RS2 = 10 \text{ k}\Omega$

$$R1 = \frac{RS2 \times (V_{BUCK} - V_{ref})}{V_{ref}} \text{ (Ohm)} \quad (23)$$

$$R1 = \frac{10000 \times (V_{BUCK} - 1)}{1} \text{ (Ohm)} \quad (24)$$

$$R2 = \frac{f_c \times V_{ramp} \times R1}{f_{LC} \times V_{BAT}} \text{ (Ohm)} \quad (25)$$

Calculate C1 based on placing a zero at 50% to 75% of the output filter double pole frequency.

$$C1 = \frac{1}{\pi \times R2 \times f_{LC}} \text{ (Farad)} \quad (26)$$

Calculate C2 by placing the first pole at the ESR zero frequency.

$$C2 = \frac{C1}{(2\pi \times R2 \times C1 \times f_{ESR}) - 1} \text{ (Farad)} \quad (27)$$

Set the second pole at 0.5 the switching frequency and also set the second zero at the output filter double pole frequency.

$$R3 = \frac{R1}{\left(\frac{f_{SW}}{2} \times \frac{1}{f_{LC}}\right) - 1} \text{ (Ohm)} \quad (28)$$

$$C3 = \frac{1}{\pi \times R3 \times f_{SW}} \text{ (Farad)} \quad (29)$$

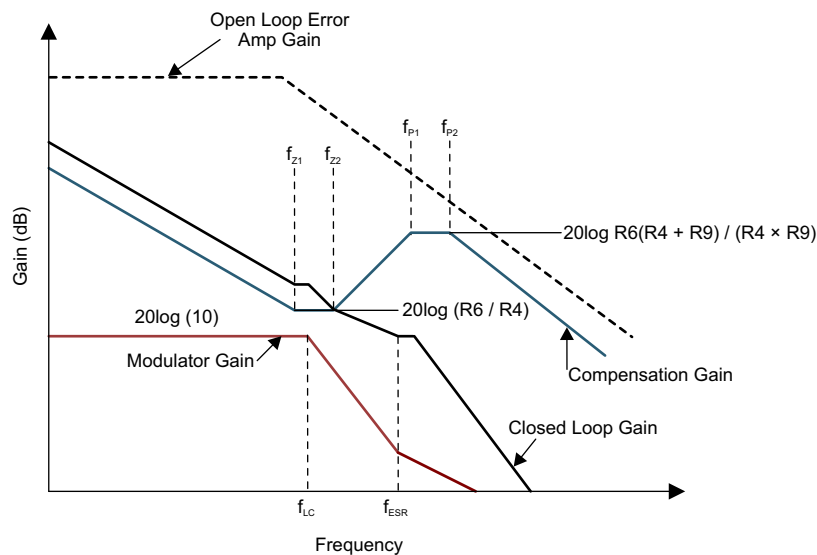

Figure 24. Type III Bode Plots

8.2.2.3 Component Calculations

8.2.2.3.1 Buck-Controllers (VBUCK1, VBUCK2)

Use Equation 30 to calculate and select the desired inductor ripple current (ΔI_L).

$$\Delta I_L = I_{\text{ripple}} = 0.4 \times I_{O(\text{max})}$$

where

- $I_{O(\text{max})}$ = Maximum output current (30)

The typical inductor ripple current is between 20% to 40% of the maximum output current.

Use Equation 31 to calculate the value of the inductor (L).

$$L = \frac{(V_{\text{BAT}(\text{max})} - V_{\text{BUCK}}) V_{\text{BUCK}}}{f_{\text{SW}} \times I_{\text{ripple}} \times V_{\text{BUCK}(\text{max})}} \text{ (Henry)}$$

where

- f_{SW} is the switching frequency of the regulator
- I_{ripple} = Allowable ripple current in the inductor, 20% to 40% of maximum $I_{O(\text{max})}$ (31)

Use Equation 32 to calculate the value of the the rms and peak current flowing in the inductor is.

$$I_{L(\text{RMS})} = \sqrt{I_O^2 + \frac{I_{\text{ripple}}^2}{12}} \text{ (Ampere)} \quad (32)$$

Use Equation 33 to calculate the inductor peak current.

$$I_{L(\text{peak})} = I_O + \frac{I_{\text{ripple}}}{2} \text{ (Ampere)} \quad (33)$$

Use Equation 34 to calculate the value of the output voltage ripple.

$$\Delta V_{\text{BUCK}} = \Delta I_L \left(\text{ESR} + \frac{1}{8 \times f_{\text{SW}} \times C_O} \right) \text{ (Volt, Peak-to-Peak)} \quad (34)$$

Usually the first term is dominant. The output ripple voltage is typically within the tolerance of the output specification.

Use Equation 35 to calculate the value of the output capacitor.

$$C_O = \frac{L(I_{O(\text{max})}^2 - I_{O(\text{min})}^2)}{V_{\text{BUCK}(\text{max})}^2 - V_{\text{BUCK}(\text{min})}^2} \text{ (Farad)}$$

where

- $I_{O(\text{max})}$ is the maximum output current
- $I_{O(\text{min})}$ is the minimum output current (35)

The difference between the maximum to minimum output current is the worst case load step in the system where:

$V_{\text{BUCK}(\text{max})}$ is the maximum tolerance of the regulated output voltage.

$V_{\text{BUCK}(\text{min})}$ is the minimum tolerance of the regulated output voltage.

8.2.2.4 Power Dissipation

The power dissipation is largely dependent on the MOSFET driver current and input voltage. The drive current is proportional to the total gate charge of the external MOSFET.

$$P_{\text{Gate}} = Q_g \times V_{\text{DR}} \times f_{\text{SW}} \text{ (Watt)} \quad (36)$$

Assuming both high-side and low-side MOSFETs are identical in a synchronous configuration, use Equation 37 to calculate the total power dissipation.

$$P_{\text{controller1}} = 2 \times Q_g \times f_{\text{SW}} \times V_{\text{BAT}} \text{ (Watt) per channel} \quad (37)$$

The total power dissipation for the dual-channel controller is:

$$P_{\text{controller 1 and 2}} = 4 \times Q_g \times f_{\text{SW}} \times V_{\text{BAT}} \text{ (Watt)} \quad (38)$$

Use Equation 39 to calculate the device power consumption.

$$P_{\text{IC}} = I_q \times V_{\text{BAT}} \text{ (Watt)} \quad (39)$$

Use Equation 40 to calculate the power of the standby linear regulator.

$$P_{\text{STBY_REG}} = (V_{\text{INSB}} - V_{\text{STBY}}) \times I_{\text{VSTBY}} \text{ (Watt)} \quad (40)$$

Use Equation 41 to calculate the power of the linear regulator.

$$P_{\text{LIN_REG}} = (V_{\text{INLR}} - V_{\text{LR}}) \times I_{\text{VLR}} \text{ (Watt)} \quad (41)$$

Use Equation 39 to calculate the power of the high-side driver.

$$P_{\text{HSD}} = I_{\text{HSD}} \times 0.6 \text{ (Watts)} \text{ for up to 300-mA output current} \quad (42)$$

Therefore, use Equation 43 to calculate the total power dissipation (P_{Total}).

$$P_{\text{Total}} = P_{\text{controller 1 and 2}} + P_{\text{STBY_REG}} + P_{\text{LIN_REG}} + P_{\text{IC}} + P_{\text{HSD}} \text{ (Watt)} \quad (43)$$

8.2.2.5 Buck Regulators

8.2.2.5.1 Buck Regulator 1 (VBUCK 1)

8.2.2.5.1.1 Step 1. Calculate the Inductor Value

Use Equation 31 to find the inductor value and assume an inductor ripple current of 0.8 A.

$$L = \frac{(V_{\text{BAT(max)}} - V_{\text{BUCK}}) V_{\text{BUCK}}}{f_{\text{SW}} \times I_{\text{ripple}} \times V_{\text{BAT(max)}}} = \frac{(26 - 5)5}{250 \times 10^3 \times 0.8 \times 26} = 20.2 \times 10^{-6} \text{ (Henry)} \quad (44)$$

$L = 20.2 \mu\text{H}$, use a value of $22 \mu\text{H}$

8.2.2.5.1.2 Step 2. Inductor Peak Current

Use Equation 33 to calculate the peak inductor current ($I_{\text{L(peak)}}$).

$$I_{\text{L(peak)}} = I_O + \frac{I_{\text{ripple}}}{2} = 2 + \frac{0.8}{2} = 2.4 \text{ (Ampere)} \quad (45)$$

$I_{\text{L(peak)}} = 2.4 \text{ A}$

8.2.2.5.1.3 Step 3. Calculating the Output Capacitance (C_O)

Use Equation 35 to calculate the output capacitance.

$$C_O = \frac{L(I_{\text{O(max)}}^2 - I_{\text{O(min)}}^2)}{V_{\text{BUCK(max)}}^2 - V_{\text{BUCK(min)}}^2} = \frac{22 \times 10^{-6}(2^2 - (20 \times 10^{-3})^2)}{5.15^2 - 4.85^2} = 29.3 \times 10^{-6} \text{ (Farad)} \quad (46)$$

Assume a tolerance of $\pm 3\%$ to allow for some margin, the minimum I_O current is 20 mA. Using Equation 34, the value of the minimum output capacitor, $C_{\text{O(min)}}$, is $29.3 \mu\text{F}$. Considering temperature variations and manufacture tolerance, choose a value of $68 \mu\text{F}$ or greater for $C_{\text{O(min)}}$.

For this design, the value of C_O is $100 \mu\text{F}$.

8.2.2.5.1.4 Step 4. Calculating Loop Compensation Values

Use Equation 14 to determine the *double pole*:

$$f_{\text{LC}} = \frac{1}{2\pi\sqrt{LC_O}} = \frac{1}{2 \times 3.142\sqrt{22 \times 10^{-6} \times 100 \times 10^{-6}}} = 3990 \text{ (Hertz)} \quad (47)$$

$f_{\text{LC}} = 3.39 \text{ kHz}$

Use Equation 15 to determine the zero due to the ESR of the output capacitor C_O with $\text{ESR} = 60 \text{ m}\Omega$:

$$f_{\text{ESR}} = \frac{1}{2\pi \times C_O \times \text{ESR}} = \frac{1}{2 \times 3.142 \times 100 \times 10^{-6} \times 0.06} = 26.5 \times 10^3 \text{ (Hertz)} \quad (48)$$

$$f_{\text{ESR}} = 26.5 \text{ kHz}$$

$$f_C = 0.08 \times f_{\text{SW}} = 20 \text{ kHz}$$

Use Equation 24 and assume R27 = 10 kΩ to find the value of R23:

$$R23 = \frac{10000 \times (V_{\text{BUCK}} - 1)}{1} = \frac{10000 \times (5 - 1)}{1} = 40 \times 10^3 \text{ (Ohm)} \quad (49)$$

$$R23 = 40.2 \text{ k}\Omega$$

Use Equation 25 to find the value of R25:

$$R25 = \frac{f_C \times V_{\text{ramp}} \times R23}{f_{\text{LC}} \times V_{\text{BAT}}} = \frac{20 \times 10^3 \times 1.8 \times 40.2 \times 10^3}{3.39 \times 10^3 \times 14} = 30493 \text{ (Ohm)} \quad (50)$$

$$R25 = 30.5 \text{ k}\Omega, \text{ Choose } R25 = 29.4 \text{ k}\Omega$$

Use Equation 26 to find the value of C20:

$$C20 = \frac{1}{\pi \times R25 \times f_{\text{LC}}} = \frac{1}{3.142 \times 29.4 \times 10^3 \times 3.39 \times 10^3} = 3129 \times 10^{-12} \text{ (Farad)} \quad (51)$$

$$C20 = 3.13 \text{ nF}, \text{ Choose } C20 = 3.3 \text{ nF}$$

Use Equation 27 to find the value of C23:

$$C23 = \frac{C20}{(2\pi \times R25 \times C2 \times f_{\text{ESR}}) - 1} = \frac{3.3 \times 10^{-9}}{(2 \times 3.142 \times 29.4 \times 10^3 \times 3.3 \times 10^{-9} \times 26.5 \times 10^3) - 1} = 213 \times 10^{-12} \text{ (Farad)} \quad (52)$$

$$C23 = 213 \text{ pF}, \text{ Choose } C23 = 220 \text{ pF}$$

Use Equation 28 to find the value of R20:

$$R20 = \frac{R23}{\left(\frac{f_{\text{SW}}}{2} \times \frac{1}{f_{\text{LC}}}\right) - 1} = \frac{40 \times 10^3}{\left(\frac{250 \times 10^3}{2} \times \frac{1}{3.39 \times 10^3}\right) - 1} = 1.1 \times 10^3 \text{ (Ohm)} \quad (53)$$

$$R20 = 1.12 \text{ k}\Omega, \text{ Choose } R20 = 1.1 \text{ k}\Omega$$

Use Equation 29 to find the value of C18:

$$C18 = \frac{1}{\pi \times R20 \times f_{\text{SW}}} = \frac{1}{3.142 \times 1.1 \times 10^3 \times 250 \times 10^3} = 1.142 \times 10^{-9} \text{ (Farad)} \quad (54)$$

$$C18 = 1142 \text{ pF}, \text{ Choose } C18 = 1200 \text{ pF}$$

8.2.2.5.2 Buck Regulator 2 (VBUCK 2)

Using the same method for calculating the component values for Buck Regulator 2, with the set output conditions, the following values were selected.

8.2.2.5.2.1 Step 5. Calculate the Inductor Value

Use Equation 31 to find the inductor value and assume an inductor ripple current of 0.3 A:

$$L = 19.2 \text{ }\mu\text{H}, \text{ use a value of } 22 \text{ }\mu\text{H}$$

8.2.2.5.2.2 Step 6. Inductor Peak Current

From Equation 33, the peak inductor current is:

$$I_{L(\text{peak})} = 1.65 \text{ A}$$

8.2.2.5.2.3 Step 7. Calculating the Output Capacitance (C_O)

Assume a tolerance of $\pm 3\%$ to allow for some margin and a minimum I_O current of 20 mA. Use [Equation 35](#) to calculate the value of the output capacitor:

$C_{O(\min)} = 32.7 \mu\text{F}$, with temperature variations and manufacture tolerance choose a value of 100 μF for this design.

$$C_O = 100 \mu\text{F}$$

8.2.2.5.2.4 Step 8. Calculating Loop Compensation Values

Use [Equation 14](#) to determine the *double pole*:

$$f_{LC} = 3.39 \text{ kHz}$$

Use [Equation 15](#) to determine the zero from the ESR of the output capacitor, C_O , with $\text{ESR} = 60 \text{ m}\Omega$:

$$f_{\text{ESR}} = 26.5 \text{ kHz}$$

$$f_c = 0.8 \times f_{\text{SW}} = 20 \text{ kHz}$$

Use [Equation 24](#) and the R32 value of 17.4 k Ω :

$$R_{34} = 40.2 \text{ k}\Omega$$

Use [Equation 25](#):

$$R_{33} = 30.3 \text{ k}\Omega, \text{ Choose } R_{33} = 29.4 \text{ k}\Omega$$

Use [Equation 26](#):

$$C_{26} = 3.129 \text{ nF}, \text{ Choose } C_{26} = 3.3 \text{ nF}$$

Use [Equation 27](#):

$$C_{29} = 213 \text{ pF}, \text{ Choose } C_{29} = 220 \text{ pF}$$

Use [Equation 28](#):

$$R_{35} = 1.1 \text{ k}\Omega, \text{ Choose } R_{35} = 1.1 \text{ k}\Omega$$

Use [Equation 29](#):

$$C_{27} = 1142 \text{ pF}, \text{ Choose } C_{27} = 1200 \text{ pF}$$

8.2.3 Application Curves

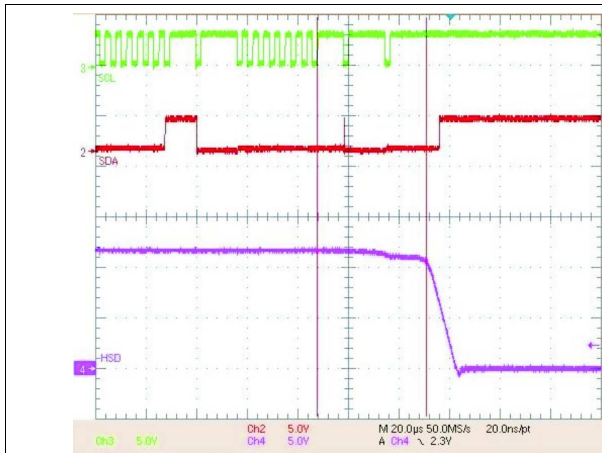

Figure 25. High-Side Driver (HSD) Output Power-Down Delay From I²C Bit Disable, $\Delta t = 43 \mu s$

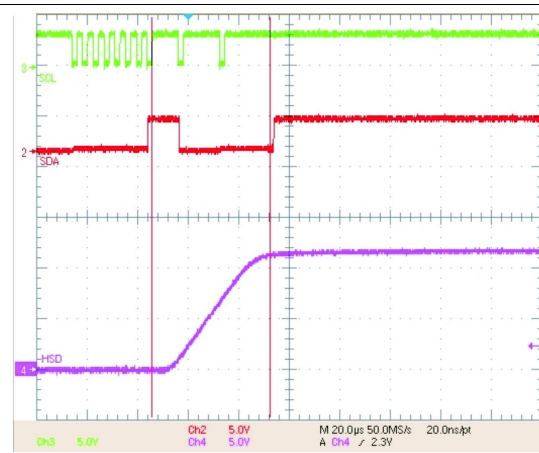

Figure 26. High-Side Driver (HSD) Output Power-On Delay From I²C Bit Enable, $\Delta t = 47 \mu s$

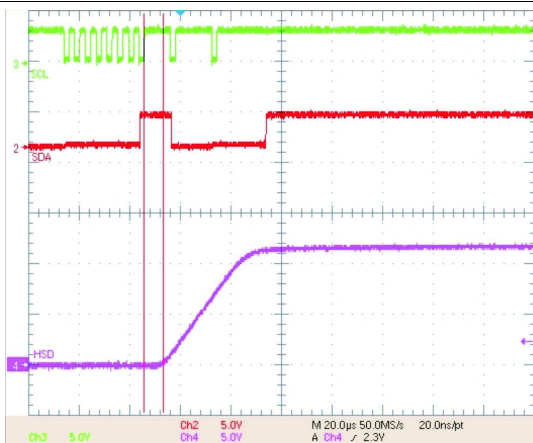

Figure 27. High-Side Driver (HSD) Output Turnon Delay From I²C Bit Enable, $\Delta t = 7.6 \mu s$

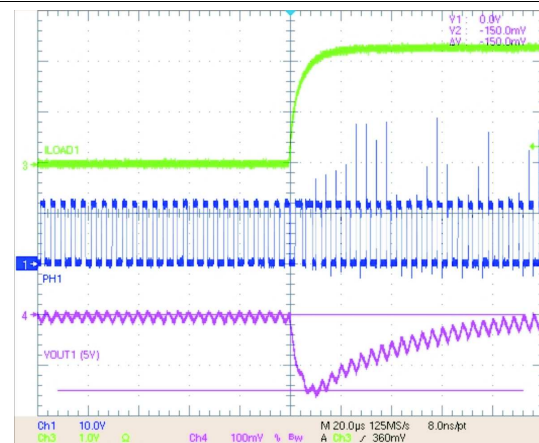

Figure 28. Load Step on VBUCK 1 From 0 A to 2 A, V_{OUT1} Droop = 150 mV

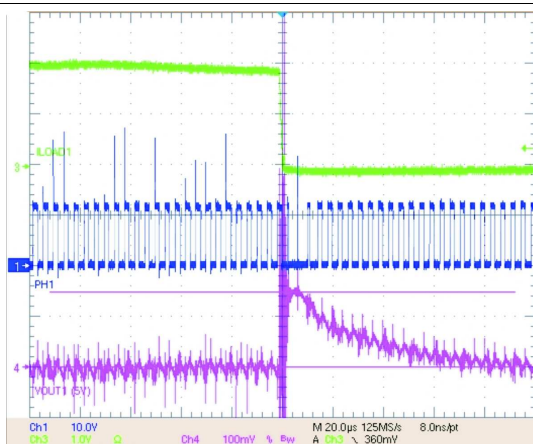

Figure 29. Load Step on VBUCK 1 From 2 A to 0 A, V_{OUT1} Overshoot = 148 mV

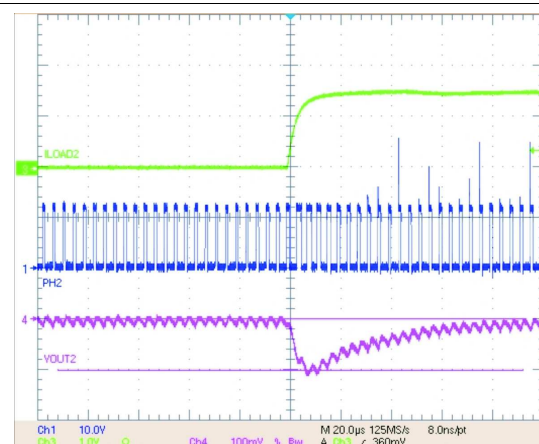

Figure 30. Load Step on VBUCK 2 From 0 A to 1.3 A, V_{OUT1} Droop = 102 mV

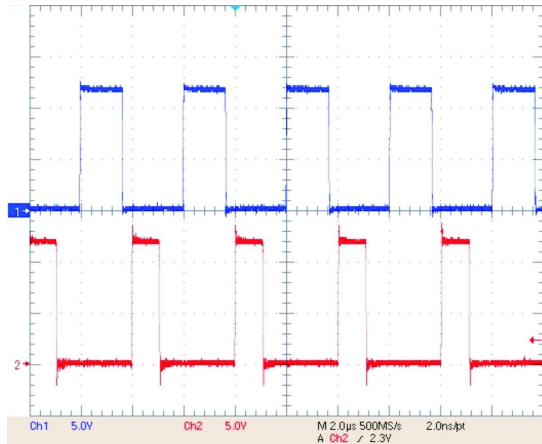

Figure 31. VBUCK 1 and VBUCK 2 Switching 180° Out of Phase

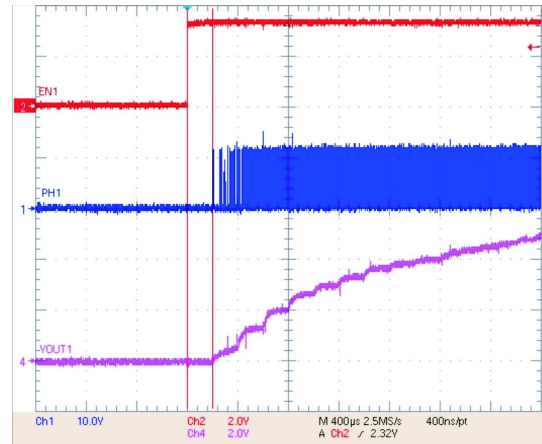

Figure 32. VBUCK 1 Turnon Delay From Enable Going High, $\Delta t = 200 \mu s$

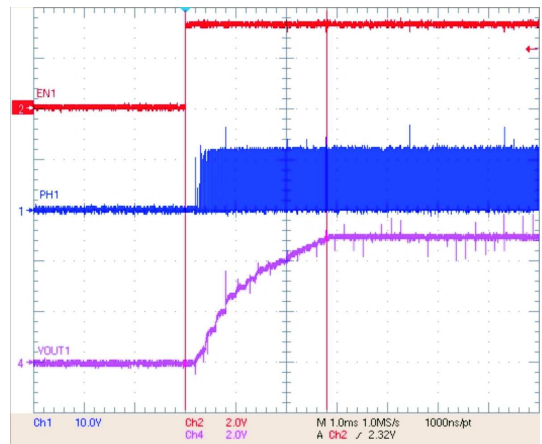

Figure 33. VBUCK 1 Power-On Delay From Enable Going High, $\Delta t = 2.8 \text{ ms}$ ($I_{Load} = 1.3 \text{ A}$)

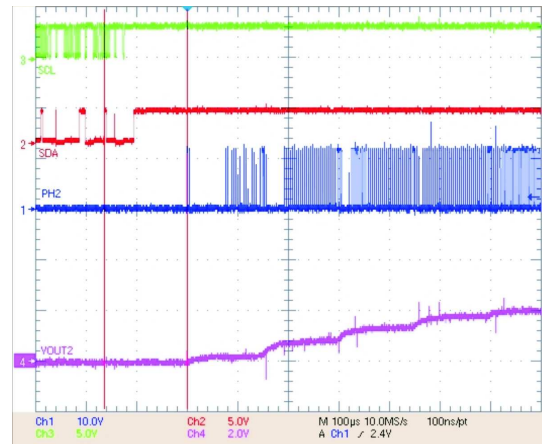

Figure 34. VBUCK 2 Turnon Delay From I²C Enable Bit Going High, $\Delta t = 164 \mu s$

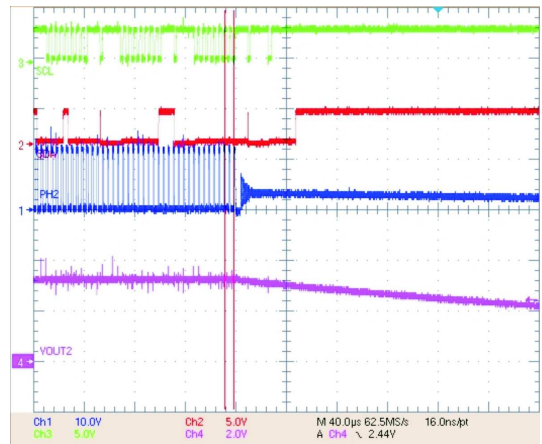

Figure 35. VBUCK 2 Turnoff Delay From I²C Enable Bit Going Low, $\Delta t = 7.2 \mu s$

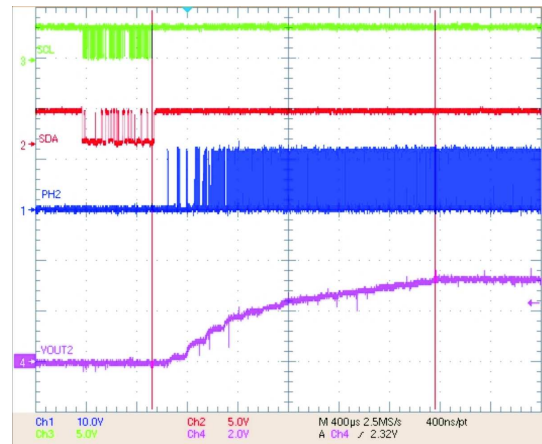

Figure 36. VBUCK 2 Power-On Delay From I²C Enable Bit Going High, $\Delta t = 2.24 \text{ ms}$

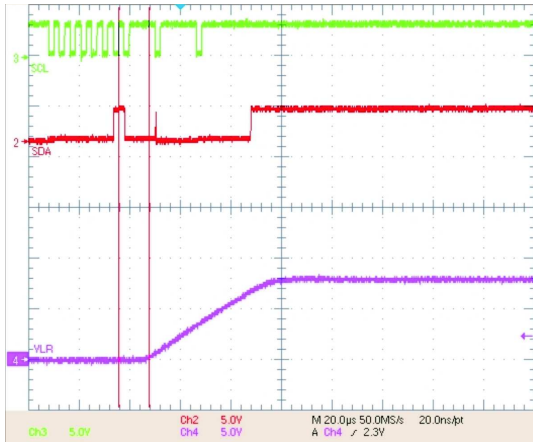

Figure 37. Linear Regulator (VLR) Turnon Delay From I²C Enable Bit Going High, $\Delta t = 12 \mu s$

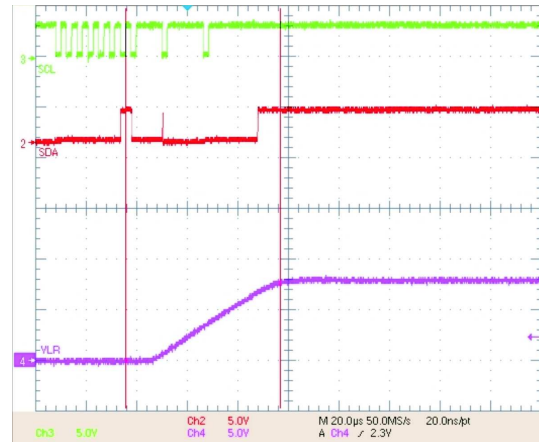

Figure 38. Linear Regulator (VLR) Power-On Delay From I²C Enable Bit Going High, $\Delta t = 61.2 \mu s$

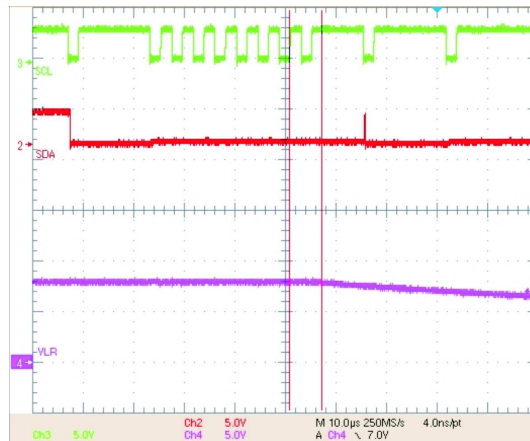

Figure 39. Linear Regulator (VLR) Turnoff Delay From I²C Enable Bit Going Low, $\Delta t = 6.4 \mu s$

8.3 System Example

8.3.1 Multiple Power Supply Configuration for Vehicle Audio Applications

Figure 40 shows an example of configuration for car-audio power-supply application. Other combinations are possible depending on the system requirements.

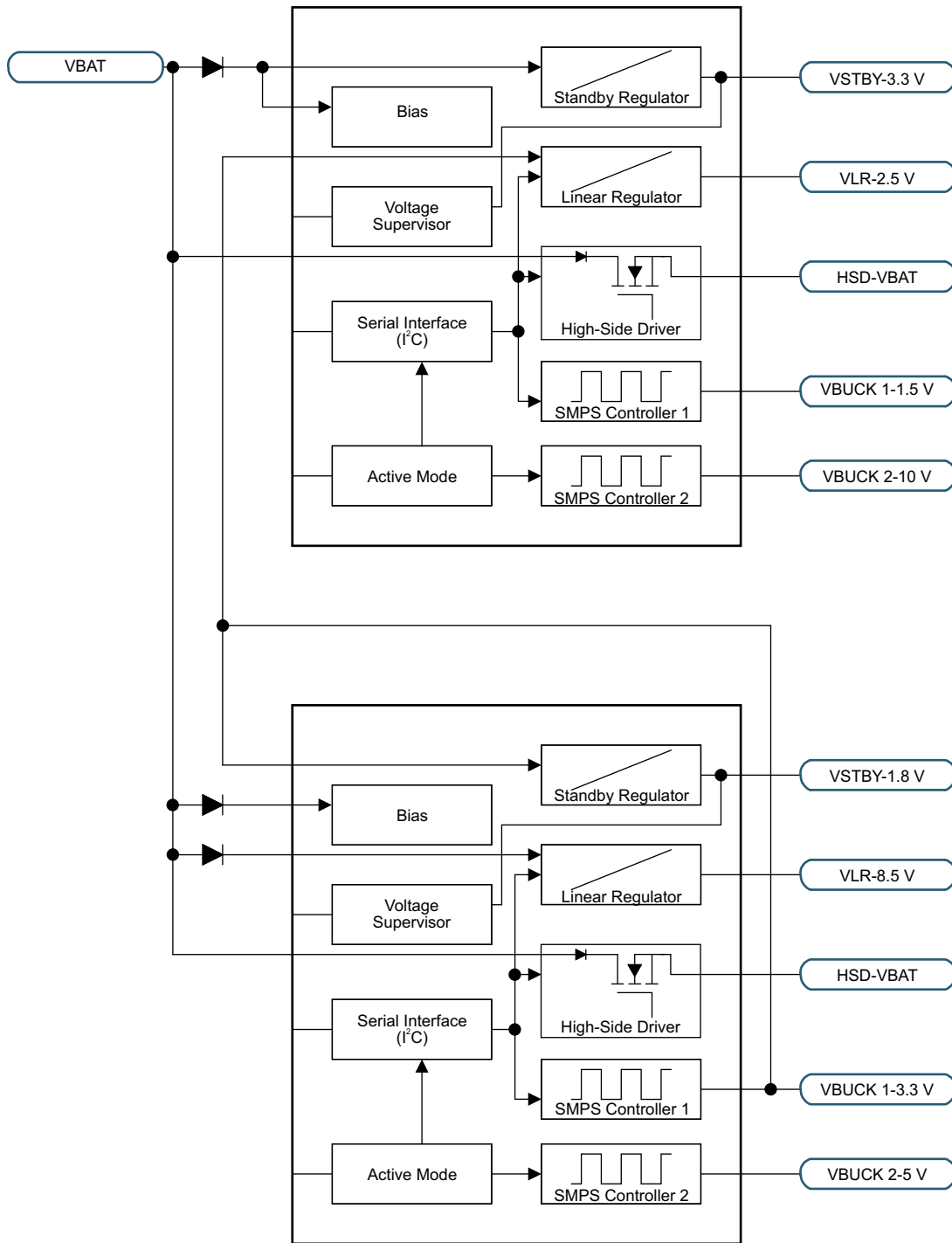

Figure 40. Multiple Power Supply for Vehicle Audio

9 Power Supply Recommendations

Apply 5 V to 30 V to the VBAT and VBATP pins. Apply 1.8 V to 30 V to the VINSB and VINLR pins.

10 Layout

10.1 Layout Guidelines

10.1.1 Grounding and Circuit Layout Considerations

The TPS43331-Q1 has two separate ground termination (AGND and PGND) pins. The ground signal consists of a plane to minimize impedance. Try to separate the low-signal ground termination from the power-ground signal. The high-power noisy circuits, such as the output, synchronous rectifier, MOSFET driver decoupling capacitor, and the input capacitor, should be connected to the PGND plane. The AGND plane should only make a single point connection to the PGND plane.

The sensitive nodes, such as the feedback resistor divider, oscillator resistor (to set frequency), current sense, and compensation circuitry, should be connected to the AGND plane.

Try and minimize the high current-carrying loops to a minimum by ensuring optimal component placement. Ensure the bypass capacitors are located as close as possible to the respective power and ground pins.

Sensitive circuits, such as sense feedback, frequency setting resistor for the oscillator, current sense and compensation circuits, should not be located near the dv/dt nodes which include the gate drive outputs, phase pins, and boost circuits (bootstrap).

10.2 Layout Example

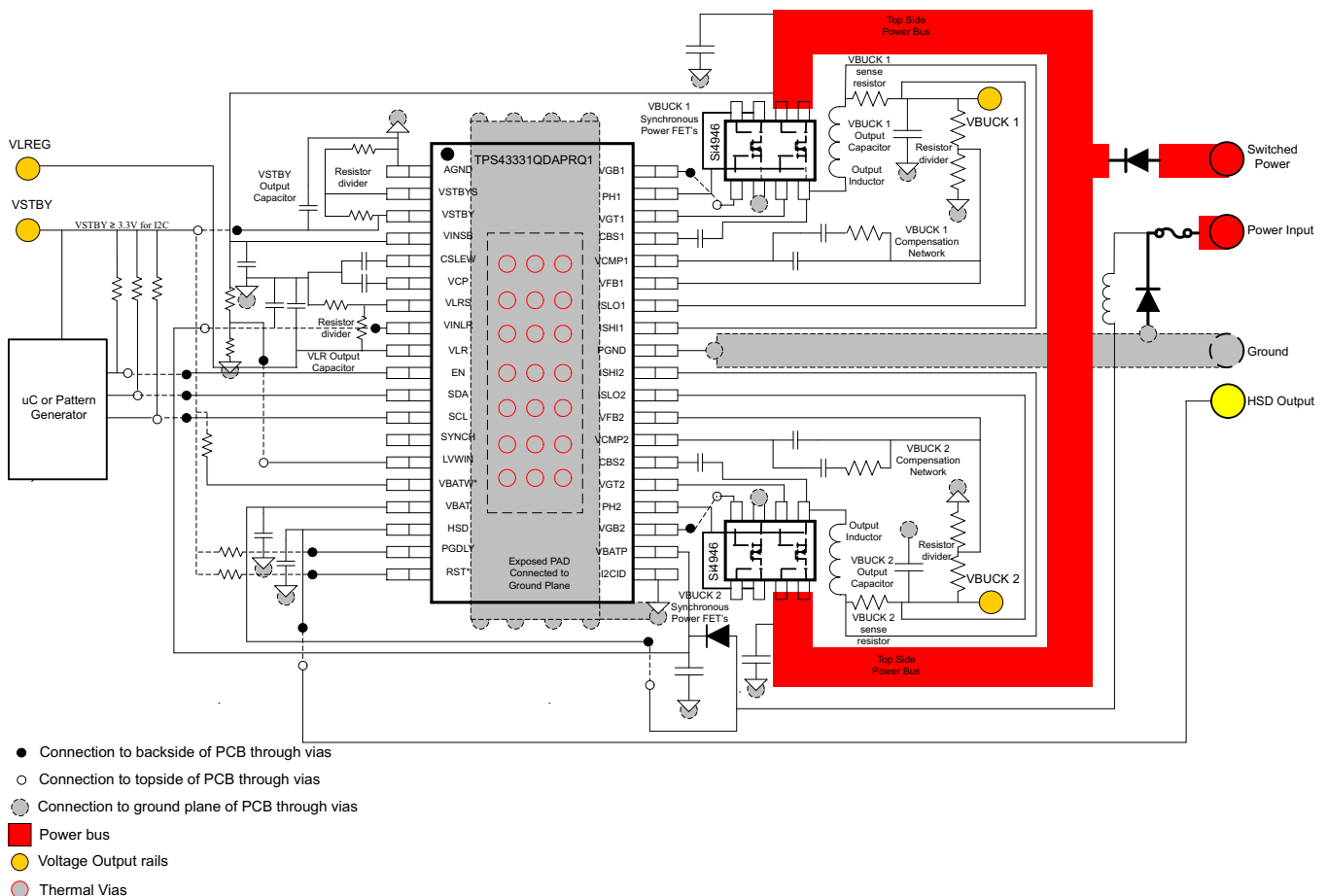

Figure 41. PCB Layout

10.3 Power Dissipation Derating

The power dissipation curve (see [Figure 42](#)) is based on attachment of the exposed power pad to the printed circuit board with multi layer FR4. The data is based of JEDEC JESD 51-5 standard board with thermal vias and high-K profile. The user must review [PowerPAD Thermally Enhanced Package Application Report](#) for recommended method of exposed pad attachment.

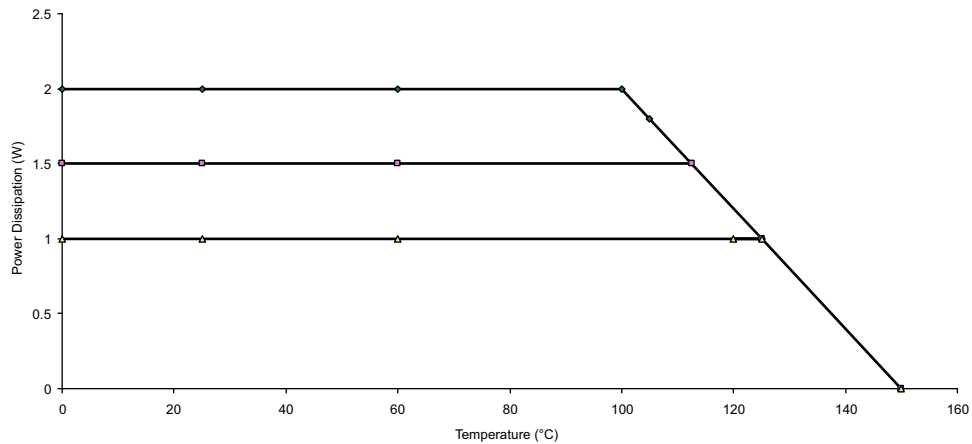

Figure 42. Power Dissipation Derating

11 器件和文档支持

11.1 文档支持

11.1.1 相关文档

请参阅如下相关文档：

德州仪器 (TI)，《[PowerPAD 热增强型封装应用报告](#)》

11.2 接收文档更新通知

要接收文档更新通知，请导航至德州仪器 TI.com.cn 上的器件产品文件夹。请单击右上角的 [通知我](#) 进行注册，即可收到任意产品信息更改每周摘要。有关更改的详细信息，请查看任意已修订文档中包含的修订历史记录。

11.3 社区资源

下列链接提供到 TI 社区资源的连接。链接的内容由各个分销商“按照原样”提供。这些内容并不构成 TI 技术规范，并且不一定反映 TI 的观点；请参阅 TI 的 [《使用条款》](#)。

TI E2E™ 在线社区 [TI 的工程师对工程师 \(E2E\) 社区](#)。此社区的创建目的在于促进工程师之间的协作。在 e2e.ti.com 中，您可以咨询问题、分享知识、拓展思路并与同行工程师一道帮助解决问题。

设计支持 [TI 参考设计支持](#) 可帮助您快速查找有帮助的 E2E 论坛、设计支持工具以及技术支持的联系信息。

11.4 商标

PowerPAD, E2E are trademarks of Texas Instruments.
All other trademarks are the property of their respective owners.

11.5 静电放电警告



ESD 可能会损坏该集成电路。德州仪器 (TI) 建议通过适当的预防措施处理所有集成电路。如果不遵守正确的处理措施和安装程序，可能会损坏集成电路。

ESD 的损坏小至导致微小的性能降级，大至整个器件故障。精密的集成电路可能更容易受到损坏，这是因为非常细微的参数更改都可能会导致器件与其发布的规格不相符。

11.6 Glossary

[SLYZ022](#) — *TI Glossary*.

This glossary lists and explains terms, acronyms, and definitions.

12 机械、封装和可订购信息

以下页面包括机械、封装和可订购信息。这些信息是指定器件的最新可用数据。这些数据发生变化时，我们可能不会另行通知或修订此文档。如欲获取此产品说明书的浏览器版本，请参阅左侧的导航栏。

PACKAGING INFORMATION

Orderable Device	Status (1)	Package Type	Package Drawing	Pins	Package Qty	Eco Plan (2)	Lead finish/ Ball material (6)	MSL Peak Temp (3)	Op Temp (°C)	Device Marking (4/5)	Samples
TPS43331QDAPRQ1	ACTIVE	HTSSOP	DAP	38	2000	RoHS & Green	NIPDAU	Level-3-260C-168 HR	-40 to 125	TPS43331Q1	Samples

(1) The marketing status values are defined as follows:

ACTIVE: Product device recommended for new designs.

LIFEBUY: TI has announced that the device will be discontinued, and a lifetime-buy period is in effect.

NRND: Not recommended for new designs. Device is in production to support existing customers, but TI does not recommend using this part in a new design.

PREVIEW: Device has been announced but is not in production. Samples may or may not be available.

OBSOLETE: TI has discontinued the production of the device.

(2) **RoHS:** TI defines "RoHS" to mean semiconductor products that are compliant with the current EU RoHS requirements for all 10 RoHS substances, including the requirement that RoHS substance do not exceed 0.1% by weight in homogeneous materials. Where designed to be soldered at high temperatures, "RoHS" products are suitable for use in specified lead-free processes. TI may reference these types of products as "Pb-Free".

RoHS Exempt: TI defines "RoHS Exempt" to mean products that contain lead but are compliant with EU RoHS pursuant to a specific EU RoHS exemption.

Green: TI defines "Green" to mean the content of Chlorine (Cl) and Bromine (Br) based flame retardants meet JS709B low halogen requirements of <=1000ppm threshold. Antimony trioxide based flame retardants must also meet the <=1000ppm threshold requirement.

(3) MSL, Peak Temp. - The Moisture Sensitivity Level rating according to the JEDEC industry standard classifications, and peak solder temperature.

(4) There may be additional marking, which relates to the logo, the lot trace code information, or the environmental category on the device.

(5) Multiple Device Markings will be inside parentheses. Only one Device Marking contained in parentheses and separated by a "-" will appear on a device. If a line is indented then it is a continuation of the previous line and the two combined represent the entire Device Marking for that device.

(6) Lead finish/Ball material - Orderable Devices may have multiple material finish options. Finish options are separated by a vertical ruled line. Lead finish/Ball material values may wrap to two lines if the finish value exceeds the maximum column width.

Important Information and Disclaimer:The information provided on this page represents TI's knowledge and belief as of the date that it is provided. TI bases its knowledge and belief on information provided by third parties, and makes no representation or warranty as to the accuracy of such information. Efforts are underway to better integrate information from third parties. TI has taken and continues to take reasonable steps to provide representative and accurate information but may not have conducted destructive testing or chemical analysis on incoming materials and chemicals. TI and TI suppliers consider certain information to be proprietary, and thus CAS numbers and other limited information may not be available for release.

In no event shall TI's liability arising out of such information exceed the total purchase price of the TI part(s) at issue in this document sold by TI to Customer on an annual basis.

TAPE AND REEL INFORMATION



QUADRANT ASSIGNMENTS FOR PIN 1 ORIENTATION IN TAPE



*All dimensions are nominal

Device	Package Type	Package Drawing	Pins	SPQ	Reel Diameter (mm)	Reel Width W1 (mm)	A0 (mm)	B0 (mm)	K0 (mm)	P1 (mm)	W (mm)	Pin1 Quadrant
TPS43331QDAPRQ1	HTSSOP	DAP	38	2000	330.0	24.4	8.6	13.0	1.8	12.0	24.0	Q1

TAPE AND REEL BOX DIMENSIONS

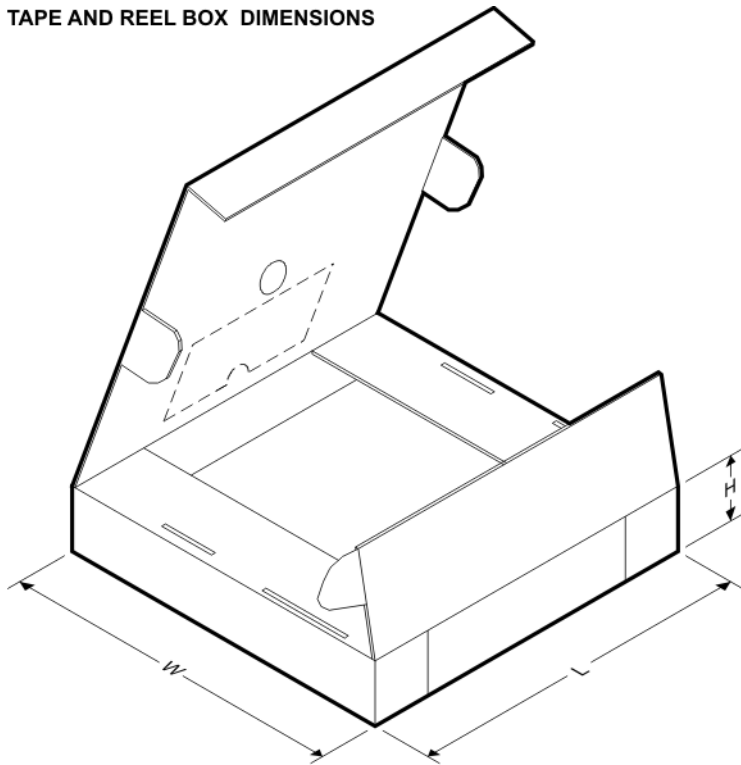

*All dimensions are nominal

Device	Package Type	Package Drawing	Pins	SPQ	Length (mm)	Width (mm)	Height (mm)
TPS43331QDAPRQ1	HTSSOP	DAP	38	2000	350.0	350.0	43.0

MECHANICAL DATA

DAP (R-PDSO-G38) PowerPAD™ PLASTIC SMALL-OUTLINE PACKAGE

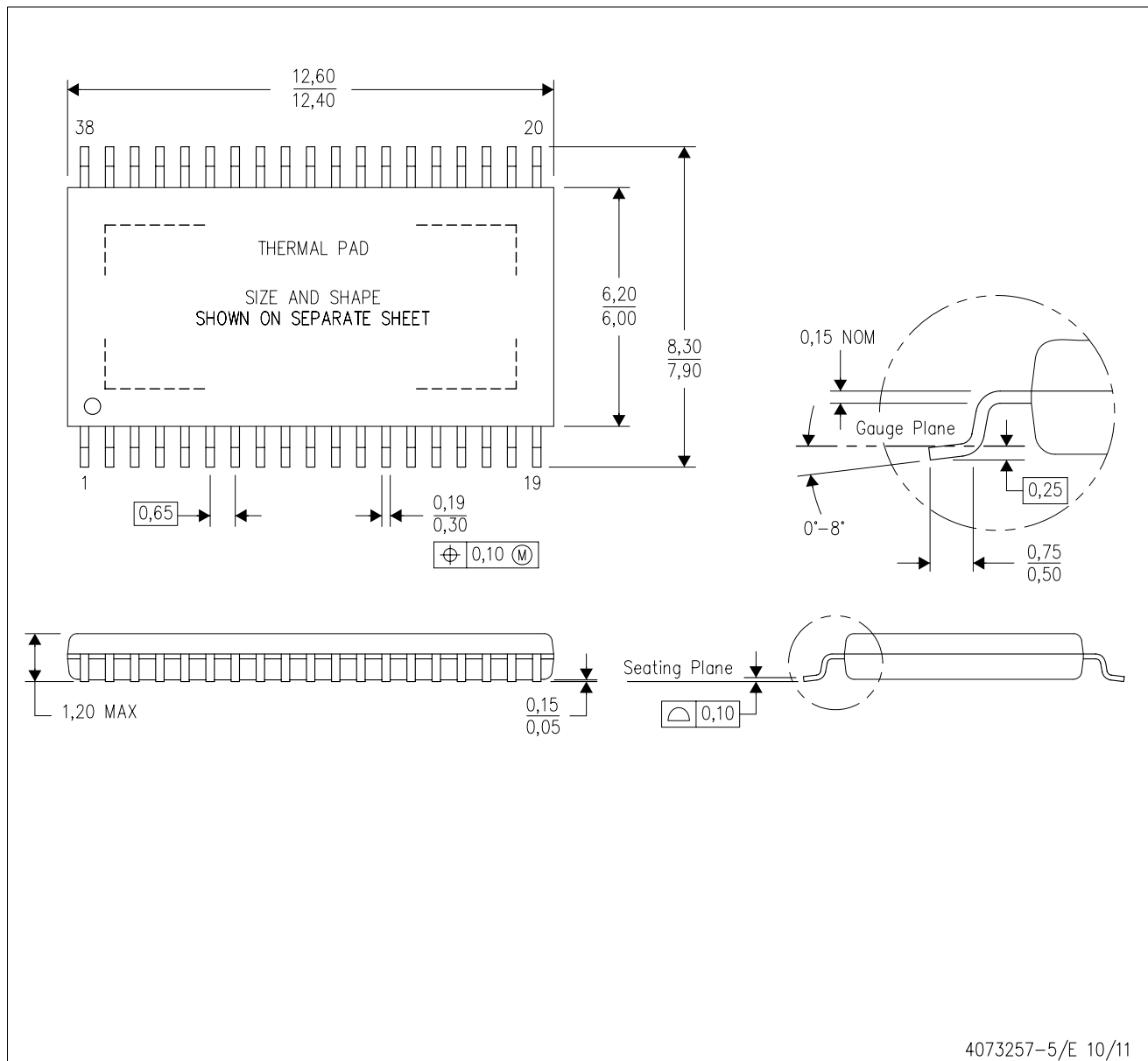

- NOTES:
- A. All linear dimensions are in millimeters.
 - B. This drawing is subject to change without notice.
 - C. Body dimensions do not include mold flash or protrusion. Mold flash and protrusion shall not exceed 0.15 per side.
 - D. This package is designed to be soldered to a thermal pad on the board. Refer to Technical Brief, PowerPad Thermally Enhanced Package, Texas Instruments Literature No. SLMA002 for information regarding recommended board layout. This document is available at www.ti.com <<http://www.ti.com>>.
 - E. See the additional figure in the Product Data Sheet for details regarding the exposed thermal pad features and dimensions.
- ⚠ Falls within JEDEC MO-153 Variation DDT-1.

PowerPAD is a trademark of Texas Instruments.

THERMAL PAD MECHANICAL DATA

DAP (R-PDSO-G38)

PowerPAD™ PLASTIC SMALL OUTLINE

THERMAL INFORMATION

This PowerPAD™ package incorporates an exposed thermal pad that is designed to be attached to a printed circuit board (PCB). The thermal pad must be soldered directly to the PCB. After soldering, the PCB can be used as a heatsink. In addition, through the use of thermal vias, the thermal pad can be attached directly to the appropriate copper plane shown in the electrical schematic for the device, or alternatively, can be attached to a special heatsink structure designed into the PCB. This design optimizes the heat transfer from the integrated circuit (IC).

For additional information on the PowerPAD package and how to take advantage of its heat dissipating abilities, refer to Technical Brief, PowerPAD Thermally Enhanced Package, Texas Instruments Literature No. SLMA002 and Application Brief, PowerPAD Made Easy, Texas Instruments Literature No. SLMA004. Both documents are available at www.ti.com.

The exposed thermal pad dimensions for this package are shown in the following illustration.

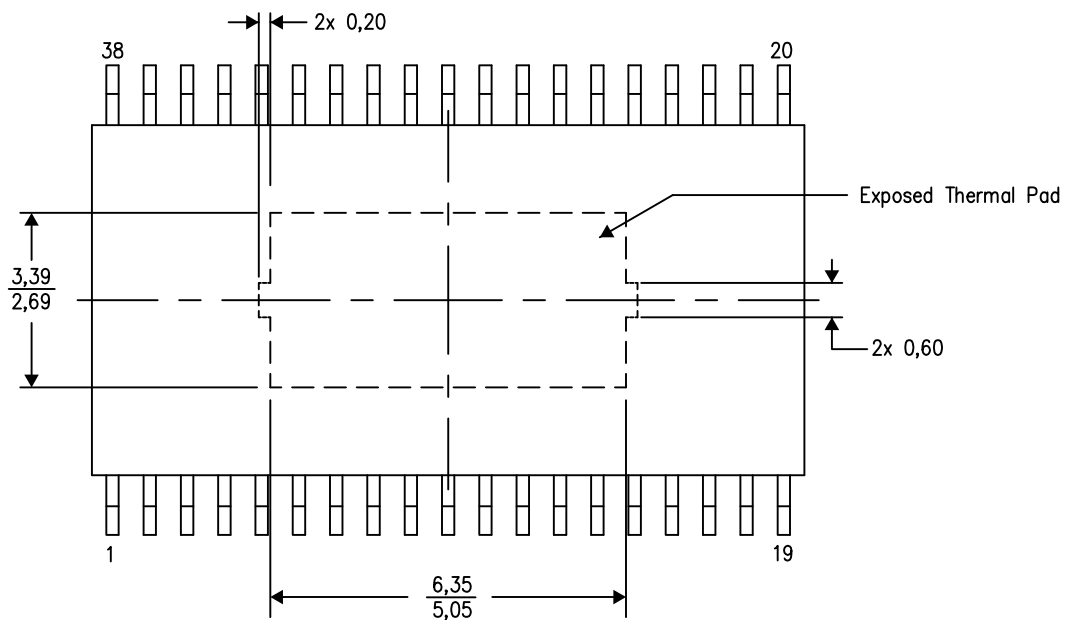

Top View
Exposed Thermal Pad Dimensions

4206319-7/M 09/13

NOTE: All linear dimensions are in millimeters

PowerPAD is a trademark of Texas Instruments.

LAND PATTERN DATA

DAP (R-PDSO-G38) PowerPAD™ PLASTIC SMALL OUTLINE PACKAGE

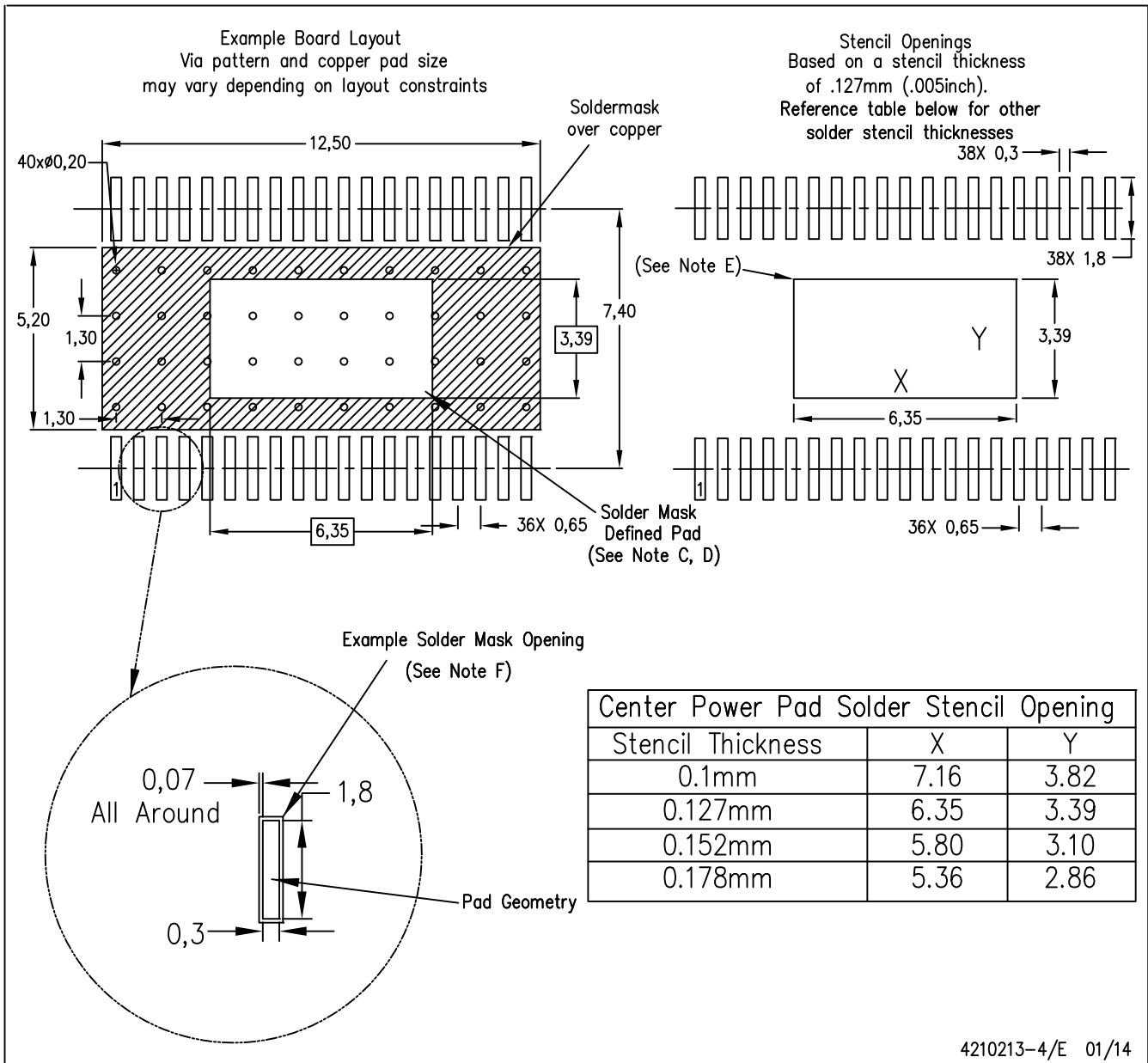

- NOTES:
- All linear dimensions are in millimeters.
 - This drawing is subject to change without notice.
 - Customers should place a note on the circuit board fabrication drawing not to alter the center solder mask defined pad.
 - This package is designed to be soldered to a thermal pad on the board. Refer to Technical Brief, PowerPad Thermally Enhanced Package, Texas Instruments Literature No. SLMA002, SLMA004, and also the Product Data Sheets for specific thermal information, via requirements, and recommended board layout. These documents are available at www.ti.com <<http://www.ti.com>>. Publication IPC-7351 is recommended for alternate designs.
 - Laser cutting apertures with trapezoidal walls and also rounding corners will offer better paste release. Customers should contact their board assembly site for stencil design recommendations. Refer to IPC-7525 for other stencil recommendations.
 - Contact the board fabrication site for recommended soldermask tolerances.

PowerPAD is a trademark of Texas Instruments

重要声明和免责声明

TI 均以“原样”提供技术性及其可靠性数据（包括数据表）、设计资源（包括参考设计）、应用或其他设计建议、网络工具、安全信息和其他资源，不保证其中不含任何瑕疵，且不做任何明示或暗示的担保，包括但不限于对适销性、适合某特定用途或不侵犯任何第三方知识产权的暗示担保。

所述资源可供专业开发人员应用TI 产品进行设计使用。您将对以下行为独自承担全部责任：(1) 针对您的应用选择合适的TI 产品；(2) 设计、验证并测试您的应用；(3) 确保您的应用满足相应标准以及任何其他安全、安保或其他要求。所述资源如有变更，恕不另行通知。TI 对您使用所述资源的授权仅限于开发资源所涉及TI 产品的相关应用。除此之外不得复制或展示所述资源，也不提供其它TI 或任何第三方的知识产权授权许可。如因使用所述资源而产生任何索赔、赔偿、成本、损失及债务等，TI 对此概不负责，并且您须赔偿由此对TI 及其代表造成的损害。

TI 所提供产品均受TI 的销售条款 (<http://www.ti.com.cn/zh-cn/legal/termsofsale.html>) 以及ti.com.cn上或随附TI产品提供的其他可适用条款的约束。TI提供所述资源并不扩展或以其他方式更改TI 针对TI 产品所发布的可适用的担保范围或担保免责声明。

邮寄地址：上海市浦东新区世纪大道 1568 号中建大厦 32 楼，邮政编码：200122

Copyright © 2020 德州仪器半导体技术（上海）有限公司