

SN54F257, SN74F257 QUADRUPLE 2-LINE TO 1-LINE DATA SELECTORS/MULTIPLEXERS WITH 3-STATE OUTPUTS

SDFS065A – D2932, MARCH 1987 – REVISED OCTOBER 1993

- 3-State Outputs Interface Directly With System Bus
- Provides Bus Interface From Multiple Sources in High-Performance Systems
- Package Options Include Plastic Small-Outline Packages, Ceramic Chip Carriers, and Standard Plastic and Ceramic 300-mil DIPs

description

The 'F257 is designed to multiplex signals from 4-bit data sources to 4-output data lines in bus-organized systems. The 3-state outputs will not load the data lines when the output enable (\overline{OE}) input is at a high logic level.

The SN54F257 is characterized for operation over the full military temperature range of -55°C to 125°C . The SN74F257 is characterized for operation from 0°C to 70°C .

FUNCTION TABLE

INPUTS				OUTPUT Y
\overline{OE}	$\overline{A/B}$	A	B	
H	X	X	X	Z
L	L	L	X	L
L	L	H	X	H
L	H	X	L	L
L	H	X	H	H

logic symbol†

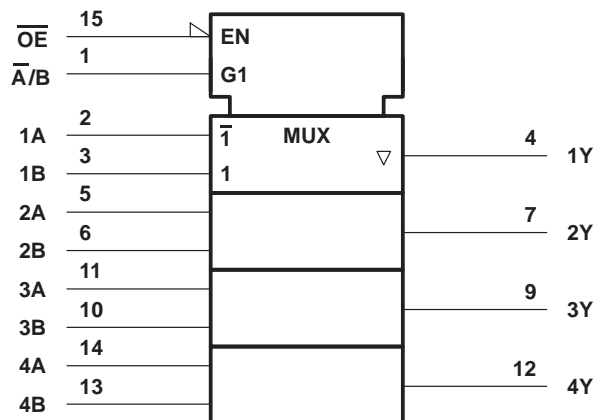

† This symbol is in accordance with ANSI/IEEE Std 91-1984 and IEC Publication 617-12. Pin numbers shown are for the D, J, and N packages.

SN54F257 . . . J PACKAGE
SN74F257 . . . D OR N PACKAGE
(TOP VIEW)

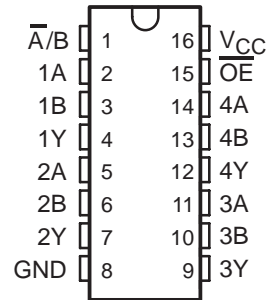

SN54F257 . . . FK PACKAGE
(TOP VIEW)

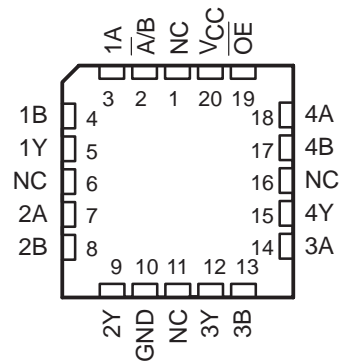

NC – No internal connection

SN54F257, SN74F257 QUADRUPLE 2-LINE TO 1-LINE DATA SELECTORS/MULTIPLEXERS WITH 3-STATE OUTPUTS

SDFS065A – D2932, MARCH 1987 – REVISED OCTOBER 1993

logic diagram (positive logic)

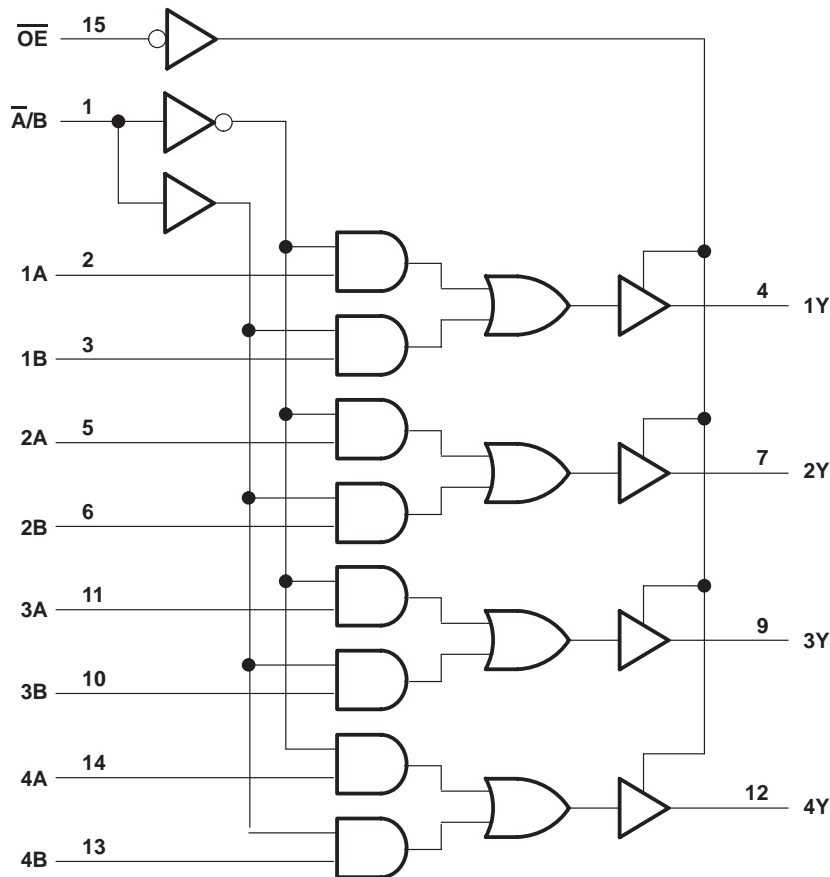

Pin numbers shown are for the D, J, and N packages.

absolute maximum ratings over operating free-air temperature range (unless otherwise noted)†

Supply voltage range, V_{CC}	-0.5 V to 7 V
Input voltage range (see Note 1)	-1.2 V to 7 V
Input current range	-30 mA to 5 mA
Voltage range applied to any output in the disabled or power-off state	-0.5 V to 5.5 V
Voltage range applied to any output in the high state	-0.5 V to V_{CC}
Current into any output in the low state: SN54F257	40 mA
SN74F257	48 mA
Operating free-air temperature range: SN54F257	-55°C to 125°C
SN74F257	0°C to 70°C
Storage temperature range	-65°C to 150°C

† Stresses beyond those listed under "absolute maximum ratings" may cause permanent damage to the device. These are stress ratings only and functional operation of the device at these or any other conditions beyond those indicated under "recommended operating conditions" is not implied. Exposure to absolute-maximum-rated conditions for extended periods may affect device reliability.

NOTE 1: The input voltage ratings may be exceeded provided the input current ratings are observed.



SN54F257, SN74F257 QUADRUPLE 2-LINE TO 1-LINE DATA SELECTORS/MULTIPLEXERS WITH 3-STATE OUTPUTS

SDFS065A – D2932, MARCH 1987 – REVISED OCTOBER 1993

recommended operating conditions

		SN54F257			SN74F257			UNIT
		MIN	NOM	MAX	MIN	NOM	MAX	
V_{CC}	Supply voltage	4.5	5	5.5	4.5	5	5.5	V
V_{IH}	High-level input voltage	2			2			V
V_{IL}	Low-level input voltage			0.8			0.8	V
I_{IK}	Input clamp current			-18			-18	mA
I_{OH}	High-level output current			-3			-3	mA
I_{OL}	Low-level output current			20			24	mA
T_A	Operating free-air temperature	-55		125	0		70	°C

electrical characteristics over recommended operating free-air temperature range (unless otherwise noted)

PARAMETER	TEST CONDITIONS	SN54F257			SN74F257			UNIT
		MIN	TYP†	MAX	MIN	TYP†	MAX	
V_{IK}	$V_{CC} = 4.5\text{ V}$, $I_I = -18\text{ mA}$			-1.2			-1.2	V
V_{OH}	$V_{CC} = 4.5\text{ V}$	$I_{OH} = -1\text{ mA}$		2.5	3.4	2.5	3.4	V
		$I_{OH} = -3\text{ mA}$		2.4	3.3	2.4	3.3	
	$V_{CC} = 4.75\text{ V}$,	$I_{OH} = -1\text{ mA to } -3\text{ mA}$				2.7		
V_{OL}	$V_{CC} = 4.5\text{ V}$	$I_{OL} = 20\text{ mA}$		0.3	0.5			V
		$I_{OL} = 24\text{ mA}$				0.35	0.5	
I_{OZH}	$V_{CC} = 5.5\text{ V}$, $V_O = 2.7\text{ V}$			50			50	μA
I_{OZL}	$V_{CC} = 5.5\text{ V}$, $V_O = 0.5\text{ V}$			-50			-50	μA
I_I	$V_{CC} = 5.5\text{ V}$, $V_I = 7\text{ V}$			0.1			0.1	mA
I_{IH}	$V_{CC} = 5.5\text{ V}$, $V_I = 2.7\text{ V}$			20			20	μA
I_{IL}	$V_{CC} = 5.5\text{ V}$, $V_I = 0.5\text{ V}$			-0.6			-0.6	mA
$I_{OS}‡$	$V_{CC} = 5.5\text{ V}$, $V_O = 0$	-60		-150	-60		-150	mA
I_{CCH}	$V_{CC} = 5.5\text{ V}$, See Note 2	Condition A		9	15	9	15	mA
I_{CCL}		Condition B		14.5	22	14.5	22	
I_{CCZ}		Condition C		15	23	15	23	

† All typical values are at $V_{CC} = 5\text{ V}$, $T_A = 25^\circ\text{C}$.

‡ Not more than one output should be shorted at a time, and the duration of the short circuit should not exceed one second.

NOTE 2: I_{CC} is measured with the outputs open under the following conditions:

- A. A/B and all B inputs at 4.5 V, other inputs grounded
- B. All B inputs at 4.5 V, other inputs grounded
- C. OE and all B data inputs at 4.5 V, other inputs grounded



SN54F257, SN74F257 QUADRUPLE 2-LINE TO 1-LINE DATA SELECTORS/MULTIPLEXERS WITH 3-STATE OUTPUTS

SDFS065A – D2932, MARCH 1987 – REVISED OCTOBER 1993

switching characteristics (see Note 3)

PARAMETER	FROM (INPUT)	TO (OUTPUT)	V _{CC} = 5 V, C _L = 50 pF, R ₁ = 500 Ω, R ₂ = 500 Ω, T _A = 25°C			V _{CC} = 4.5 V to 5.5 V, C _L = 50 pF, R ₁ = 500 Ω, R ₂ = 500 Ω, T _A = MIN to MAX†				UNIT
			'F257			SN54F257		SN74F257		
			MIN	TYP	MAX	MIN	MAX	MIN	MAX	
t _{PLH}	A or B	Any Y	2.2	4.1	6	2.2	8	2.2	7	ns
t _{PHL}			1.2	3.8	5.5	1	8	1.2	6.5	
t _{PLH}	\bar{A}/B	Any Y	3.7	9.7	13	3.7	15.5	3.7	15	ns
t _{PHL}			2.7	6.1	8.5	2.7	10.5	2.7	9.5	
t _{PZH}	\bar{G}	Any Y	2.2	5.5	7.5	2.2	9.5	2.2	8.5	ns
t _{PZL}			2.2	5.1	7.5	2.2	10	2.2	8.5	
t _{PHZ}	\bar{G}	Any Y	1.2	3.9	6	1.2	7	1.2	7	ns
t _{PLZ}			1.2	4.1	6	1.2	9.5	1.2	7	

† For conditions shown as MIN or MAX, use the appropriate value specified under recommended operating conditions.

NOTE 3: Load circuits and waveforms are shown in Section 1.

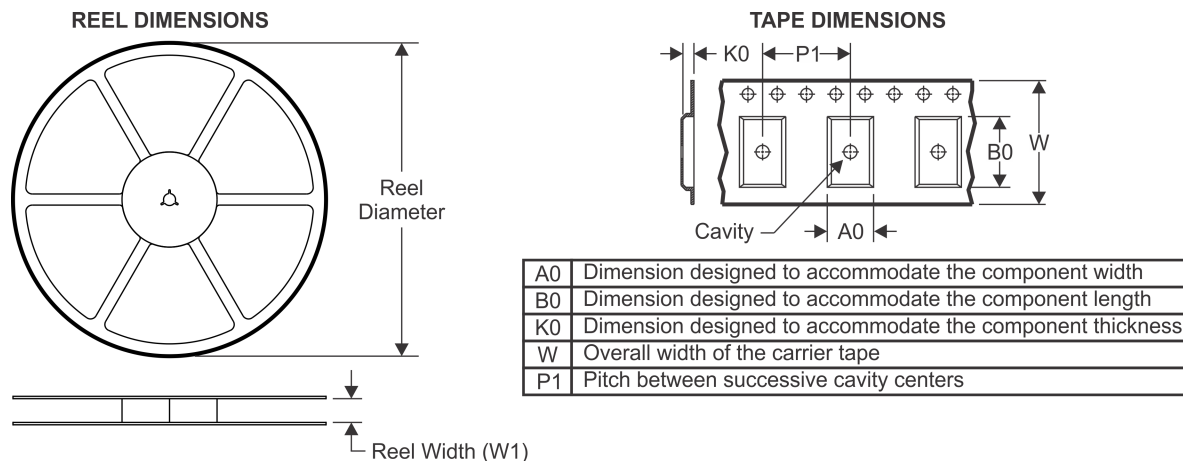
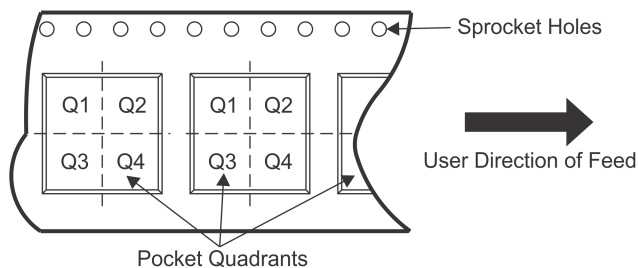

TAPE AND REEL INFORMATION

QUADRANT ASSIGNMENTS FOR PIN 1 ORIENTATION IN TAPE

*All dimensions are nominal

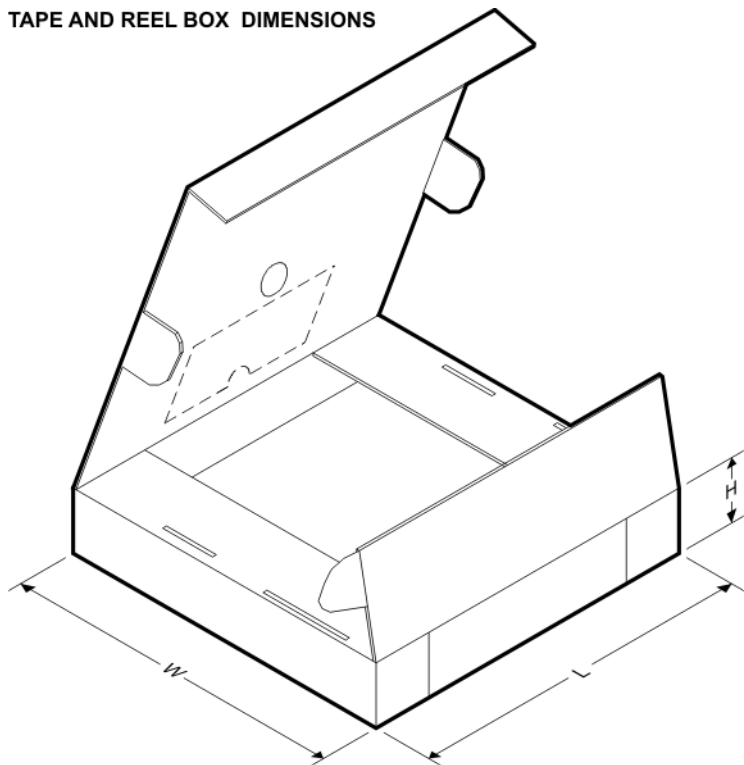
Device	Package Type	Package Drawing	Pins	SPQ	Reel Diameter (mm)	Reel Width W1 (mm)	A0 (mm)	B0 (mm)	K0 (mm)	P1 (mm)	W (mm)	Pin1 Quadrant
SN74F257DR	SOIC	D	16	2500	330.0	16.4	6.5	10.3	2.1	8.0	16.0	Q1
SN74F257NSR	SO	NS	16	2000	330.0	16.4	8.2	10.5	2.5	12.0	16.0	Q1

TAPE AND REEL BOX DIMENSIONS

*All dimensions are nominal

Device	Package Type	Package Drawing	Pins	SPQ	Length (mm)	Width (mm)	Height (mm)
SN74F257DR	SOIC	D	16	2500	340.5	336.1	32.0
SN74F257NSR	SO	NS	16	2000	853.0	449.0	35.0

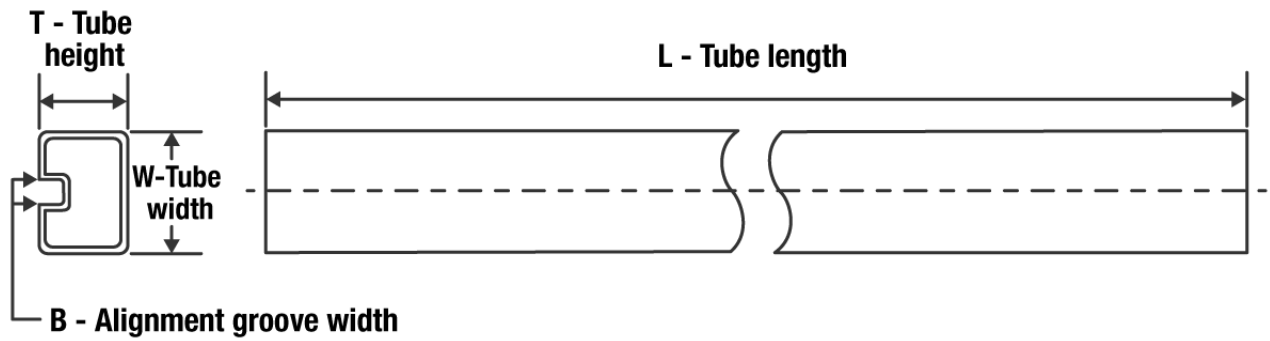
TUBE

*All dimensions are nominal

Device	Package Name	Package Type	Pins	SPQ	L (mm)	W (mm)	T (μm)	B (mm)
SN74F257D	D	SOIC	16	40	507	8	3940	4.32
SN74F257N	N	PDIP	16	25	506	13.97	11230	4.32
SN74F257N	N	PDIP	16	25	506	13.97	11230	4.32

IMPORTANT NOTICE AND DISCLAIMER

TI PROVIDES TECHNICAL AND RELIABILITY DATA (INCLUDING DATA SHEETS), DESIGN RESOURCES (INCLUDING REFERENCE DESIGNS), APPLICATION OR OTHER DESIGN ADVICE, WEB TOOLS, SAFETY INFORMATION, AND OTHER RESOURCES "AS IS" AND WITH ALL FAULTS, AND DISCLAIMS ALL WARRANTIES, EXPRESS AND IMPLIED, INCLUDING WITHOUT LIMITATION ANY IMPLIED WARRANTIES OF MERCHANTABILITY, FITNESS FOR A PARTICULAR PURPOSE OR NON-INFRINGEMENT OF THIRD PARTY INTELLECTUAL PROPERTY RIGHTS.

These resources are intended for skilled developers designing with TI products. You are solely responsible for (1) selecting the appropriate TI products for your application, (2) designing, validating and testing your application, and (3) ensuring your application meets applicable standards, and any other safety, security, regulatory or other requirements.

These resources are subject to change without notice. TI grants you permission to use these resources only for development of an application that uses the TI products described in the resource. Other reproduction and display of these resources is prohibited. No license is granted to any other TI intellectual property right or to any third party intellectual property right. TI disclaims responsibility for, and you will fully indemnify TI and its representatives against, any claims, damages, costs, losses, and liabilities arising out of your use of these resources.

TI's products are provided subject to [TI's Terms of Sale](#) or other applicable terms available either on ti.com or provided in conjunction with such TI products. TI's provision of these resources does not expand or otherwise alter TI's applicable warranties or warranty disclaimers for TI products.

TI objects to and rejects any additional or different terms you may have proposed.

Mailing Address: Texas Instruments, Post Office Box 655303, Dallas, Texas 75265
Copyright © 2022, Texas Instruments Incorporated