

目录

1	特性	1	7.2	Functional Block Diagram	27
2	应用	1	7.3	Feature Description	28
3	说明	1	7.4	Device Functional Modes	32
4	修订历史记录	2	8	Application and Implementation	33
5	Pin Configuration and Functions	3	8.1	Application Information	33
6	Specifications	5	8.2	Typical Application	34
6.1	Absolute Maximum Ratings	5	8.3	System Example	35
6.2	ESD Ratings	5	9	Power Supply Recommendations	36
6.3	Recommended Operating Conditions	5	10	Layout	36
6.4	Thermal Information	5	10.1	Layout Guidelines	36
6.5	Electrical Characteristics: $AV_{DD} = 5\text{ V}$	6	10.2	Layout Example	36
6.6	Electrical Characteristics: $AV_{DD} = 2.7\text{ V}$	8	11	器件和文档支持	37
6.7	Timing Requirements—Standalone Operation Without SDO	10	11.1	文档支持	37
6.8	Timing Requirements—Standalone Operation With SDO and Daisy-Chain Mode	11	11.2	接收文档更新通知	37
6.9	Typical Characteristics: $AV_{DD} = 5\text{ V}$	15	11.3	支持资源	37
6.10	Typical Characteristics: $AV_{DD} = 2.7\text{ V}$	22	11.4	商标	37
7	Detailed Description	26	11.5	静电放电警告	37
7.1	Overview	26	11.6	Glossary	37
			12	机械、封装和可订购信息	37

4 修订历史记录

注：之前版本的页码可能与当前版本有所不同。

Changes from Revision B (March 2016) to Revision C

Page

- Added new text to end of *Hardware Reset* section regarding two's complement mode
- Changed Table 3, Reset Values, to show updated content

Changes from Revision A (August 2008) to Revision B

Page

- 已添加 *ESD* 额定值表，特性说明部分、器件功能模式、应用和实施部分、电源建议部分、布局部分、器件和文档支持部分以及机械、封装和可订购信息部分

5 Pin Configuration and Functions

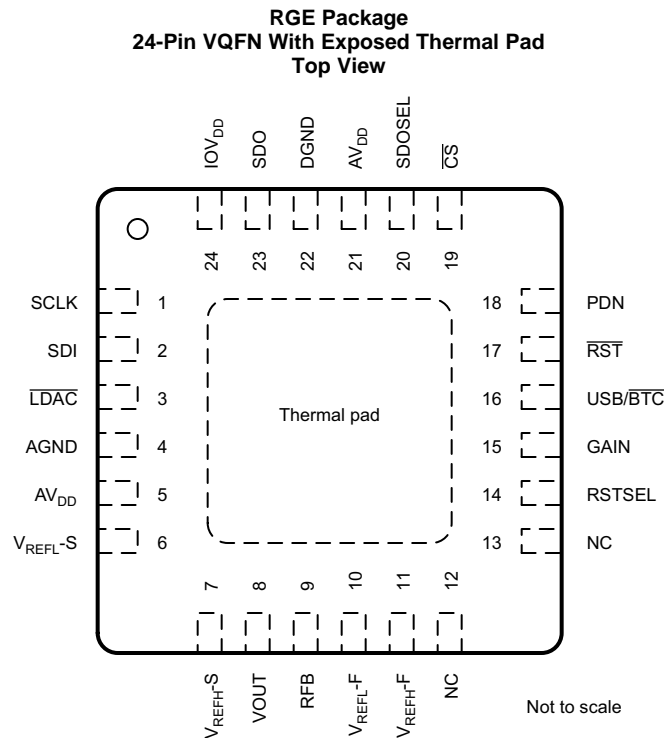

Pin Functions

PIN		I/O	DESCRIPTION
NO.	NAME		
1	SCLK	I	SPI bus serial clock input
2	SDI	I	SPI bus serial data input
3	$\overline{\text{LDAC}}$	I	Load DAC latch control input (active low). When $\overline{\text{LDAC}}$ is low, the DAC latch is transparent, and the contents of the input register are transferred to the DAC latch. The DAC output changes to the corresponding level simultaneously when the DAC latch is updated. It is recommended to connect this pin to IOV_{DD} through a pullup resistor.
4	AGND	I	Analog ground
5	AV_{DD}	I	Analog power supply
6	$\text{V}_{\text{REFL-S}}$	I	Reference low input sense
7	$\text{V}_{\text{REFH-S}}$	I	Reference high input sense
8	V_{OUT}	O	Output of output buffer
9	R_{FB}	I	Feedback resistor connected to the inverting input of the output buffer
10	$\text{V}_{\text{REFL-F}}$	I	Reference low input force
11	$\text{V}_{\text{REFH-F}}$	I	Reference high input force
12	NC	—	Do not connect
13	NC	—	Do not connect
14	RSTSEL	I	Selects the value of the output from the V_{OUT} pin after power-on or hardware reset. If RSTSEL = IOV_{DD} , then register data = 20000h. If RSTSEL = DGND, then register data = 00000h.
15	GAIN	I	Buffer gain setting. Gain = 1 when the pin is connected to DGND; Gain = 2 when the pin is connected to IOV_{DD} .
16	USB/ $\overline{\text{BTC}}$	I	Input data format selection. Input data are straight binary format when the pin is connected to IOV_{DD} , and in two's complement format when the pin is connected to DGND.
17	$\overline{\text{RST}}$	I	Reset input (active low). Logic low on this pin causes the device to perform a reset.
18	PDN	I	Power-down input (active high). Logic high on this pin forces the device into power-down status. In power-down, the V_{OUT} pin connects to AGND through a 10-k Ω resistor.

Pin Functions (continued)

PIN		I/O	DESCRIPTION
NO.	NAME		
19	\overline{CS}	I	SPI bus chip select input (active low). Data bits are not clocked into the serial shift register unless \overline{CS} is low. When \overline{CS} is high, SDO is in a high-impedance state. It is recommended to connect this pin to IOV _{DD} through a pullup resistor.
20	SDOSEL	I	SPI serial data output selection. When SDOSEL is tied to IOV _{DD} , the contents of the existing input register are shifted out from the SDO pin; this is Stand-Alone mode. When SDOSEL is tied to DGND, the contents in the SPI input shift register are shifted out from the SDO pin; this is Daisy-Chain mode for daisy-chained communication.
21	AV _{DD}	I	Analog power supply. Must be connected to pin 5.
22	DGND	I	Digital ground
23	SDO	O	SPI bus serial data output. Refer to the timing diagrams for further detail.
24	IOV _{DD}	I	Interface power. Connect to 1.8 V for 1.8-V logic, 3 V for 3-V logic, and to 5 V for 5-V logic.
Thermal pad		—	The thermal pad is internally connected to the substrate. This pad can be connected to the analog ground or left floating. Keep the thermal pad separate from the digital ground, if possible.

6 Specifications

6.1 Absolute Maximum Ratings

Over operating free-air temperature range (unless otherwise noted).⁽¹⁾

		MIN	MAX	UNIT
	AV _{DD} to AGND	-0.3	6	V
	IOV _{DD} to DGND	-0.3	6	V
	Digital input voltage to DGND	-0.3	IOV _{DD} + 0.3	V
	V _{OUT} to AGND	-0.3	AV _{DD} + 0.3	V
T _J	Maximum junction temperature		150	°C
T _{stg}	Storage temperature	-65	150	°C

(1) Stresses above those listed under *Absolute Maximum Ratings* may cause permanent damage to the device. Exposure to absolute maximum conditions for extended periods may affect device reliability.

6.2 ESD Ratings

			VALUE	UNIT
V _(ESD)	Electrostatic discharge	Human-body model (HBM), per ANSI/ESDA/JEDEC JS-001 ⁽¹⁾	±3000	V
		Charged-device model (CDM), per JEDEC specification JESD22-C101 ⁽²⁾	±1000	

(1) JEDEC document JEP155 states that 500-V HBM allows safe manufacturing with a standard ESD control process.

(2) JEDEC document JEP157 states that 250-V CDM allows safe manufacturing with a standard ESD control process.

6.3 Recommended Operating Conditions

over operating free-air temperature range (unless otherwise noted)

			MIN	NOM	MAX	UNIT
AV _{DD}	Analog power supply		2.7		5.5	V
IOV _{DD}	Interface power supply		1.7		AV _{DD}	V
V _{REFH}	Reference high input voltage	AV _{DD} = 5.5 V	1.25	5	AV _{DD}	V
		AV _{DD} = 3 V	1.25	2.5	AV _{DD}	V
V _{REFL}	Reference low input voltage		-0.2	0	0.2	V
T _A	Specified temperature		-40		105	°C

6.4 Thermal Information

THERMAL METRIC ⁽¹⁾		DAC9881	UNIT
		RGE (VQFN)	
		24 PINS	
R _{θJA}	Junction-to-ambient thermal resistance	33.5	°C/W
R _{θJC(top)}	Junction-to-case (top) thermal resistance	37.1	°C/W
R _{θJB}	Junction-to-board thermal resistance	11.3	°C/W
ψ _{JT}	Junction-to-top characterization parameter	0.5	°C/W
ψ _{JB}	Junction-to-board characterization parameter	11.4	°C/W
R _{θJC(bot)}	Junction-to-case (bottom) thermal resistance	2	°C/W

(1) For more information about traditional and new thermal metrics, see the [Semiconductor and IC Package Thermal Metrics application report](#).

6.5 Electrical Characteristics: $AV_{DD} = 5\text{ V}$

all specifications at $T_A = T_{MIN}$ to T_{MAX} , $AV_{DD} = 4.75\text{ V}$ to 5.5 V , $IOV_{DD} = 1.8\text{ V}$ to 5.5 V , $V_{REFH} = 5\text{ V}$, $V_{REFL} = 0\text{ V}$, and gain = 1X mode (unless otherwise noted)

PARAMETER	TEST CONDITIONS	MIN	TYP	MAX	UNIT	
ACCURACY⁽¹⁾						
Integral linearity error	Measured by line passing through codes 2048 and 260096	DAC9881S	±2	±3	LSB	
		DAC9881SB	±1	±2	LSB	
Differential linearity error	Measured by line passing through codes 2048 and 260096	DAC9881S	-1	±0.75	+2	LSB
		DAC9881SB		±0.5	±1	LSB
Monotonicity		18			Bits	
Zero-scale error	$T_A = 25^\circ\text{C}$, code = 2048			±16	LSB	
	T_{MIN} to T_{MAX} , code = 2048			±32	LSB	
Zero-scale drift ⁽²⁾	Code = 2048		±0.25	±0.8	ppm/°C of FSR	
Gain error	$T_A = 25^\circ\text{C}$, measured by line passing through codes 2048 and 260096		±16	±32	LSB	
Gain temperature drift ⁽²⁾	Measured by line passing through codes 2048 and 260096		±0.25	±0.4	ppm/°C	
PSRR ⁽²⁾	$V_{OUT} = \text{full-scale}$, $AV_{DD} = 5\text{ V} \pm 10\%$			32	LSB/V	
ANALOG OUTPUT⁽²⁾						
Voltage output ⁽³⁾		0		AV_{DD}	V	
Output voltage drift vs time	Device operating for 500 hours at 25°C		0.1		ppm of FSR	
	Device operating for 1000 hours at 25°C		0.2		ppm of FSR	
Output current ⁽⁴⁾			2.5		mA	
Maximum load capacitance			200		pF	
Short-circuit current			31–50		mA	
REFERENCE INPUT⁽²⁾						
V_{REFH} input voltage range	$AV_{DD} = 5.5\text{ V}$	1.25	5	AV_{DD}	V	
V_{REFH} input capacitance			5		pF	
V_{REFH} input impedance			4.5		kΩ	
V_{REFL} input voltage range		-0.2	0	0.2	V	
V_{REFL} input capacitance			4.5		pF	
V_{REFL} input impedance			5		kΩ	
DYNAMIC PERFORMANCE⁽²⁾						
Settling time	To $\pm 0.003\%$ FS, $R_L = 10\text{ k}\Omega$, $C_L = 50\text{ pF}$, code 04000h to 3C000h		5		μs	
Slew rate	From 10% to 90% of 0 V to 5 V		2.5		V/μs	
Code change glitch	Code = 1FFFFh to 20000h to 1FFFFh	$V_{REFH} = 5\text{ V}$, gain = 1X mode		37	nV-s	
		$V_{REFH} = 2.5\text{ V}$, gain = 1X mode		18	nV-s	
		$V_{REFH} = 1.25\text{ V}$, gain = 1X mode		9	nV-s	
		$V_{REFH} = 2.5\text{ V}$, gain = 2X mode		21	nV-s	
		$V_{REFH} = 1.25\text{ V}$, gain = 2X mode		10	nV-s	
Digital feedthrough	$\overline{CS} = \text{high}$, $f_{SCLK} = 1\text{ kHz}$		1		nV-s	
Output noise voltage density	$f = 1\text{ kHz}$ to 100 kHz , full-scale output	Gain = 1	24	30	$\text{nV}/\sqrt{\text{Hz}}$	
		Gain = 2	40	48	$\text{nV}/\sqrt{\text{Hz}}$	
Output noise voltage	$f = 0.1\text{ Hz}$ to 10 Hz , full-scale output		2		μV _{PP}	

(1) DAC output range is 0 V to 5 V. 1 LSB = 19 μV.

(2) Specified by design; not production tested.

(3) The output from the V_{OUT} pin = $[(V_{REFH} - V_{REFL}) / 262144] \times \text{CODE} \times \text{Buffer GAIN} + V_{REFL}$. The maximum range of V_{OUT} is 0 V to AV_{DD} . The full-scale of the output must be less than AV_{DD} ; otherwise, output saturation occurs.

(4) See Figure 26, Figure 27, and Figure 28 for details.

Electrical Characteristics: $AV_{DD} = 5\text{ V}$ (continued)

all specifications at $T_A = T_{MIN}$ to T_{MAX} , $AV_{DD} = 4.75\text{ V}$ to 5.5 V , $IOV_{DD} = 1.8\text{ V}$ to 5.5 V , $V_{REFH} = 5\text{ V}$, $V_{REFL} = 0\text{ V}$, and gain = 1X mode (unless otherwise noted)

PARAMETER	TEST CONDITIONS	MIN	TYP	MAX	UNIT
DIGITAL INPUTS⁽²⁾					
High-level input voltage, V_{IH}	$IOV_{DD} = 4.5\text{ V}$ to 5.5 V	3.8		$IOV_{DD} + 0.3$	V
	$IOV_{DD} = 2.7\text{ V}$ to 3.3 V	2.1		$IOV_{DD} + 0.3$	V
	$IOV_{DD} = 1.7\text{ V}$ to 2 V	1.5		$IOV_{DD} + 0.3$	V
Low-level input voltage, V_{IL}	$IOV_{DD} = 4.5\text{ V}$ to 5.5 V	-0.3		0.8	V
	$IOV_{DD} = 2.7\text{ V}$ to 3.3 V	-0.3		0.6	V
	$IOV_{DD} = 1.7\text{ V}$ to 2 V	-0.3		0.3	V
Digital input current (I_{IN})			± 1	± 10	μA
Digital input capacitance			5		pF
DIGITAL OUTPUT⁽²⁾					
High-level output voltage, V_{OH}	$IOV_{DD} = 2.7\text{ V}$ to 5.5 V , $I_{OH} = -1\text{ mA}$	$IOV_{DD} - 0.2$			V
	$IOV_{DD} = 1.7\text{ V}$ to 2 V , $I_{OH} = -500\text{ }\mu\text{A}$	$IOV_{DD} - 0.2$			V
Low-level output voltage, V_{OL}	$IOV_{DD} = 2.7\text{ V}$ to 5.5 V , $I_{OL} = 1\text{ mA}$			0.2	V
	$IOV_{DD} = 1.7\text{ V}$ to 2 V , $I_{OL} = 500\text{ }\mu\text{A}$			0.2	V
POWER SUPPLY					
AV_{DD}		4.75	5	5.5	V
IOV_{DD}		1.7		AV_{DD}	V
AI_{DD}	$V_{IH} = IOV_{DD}$, $V_{IL} = \text{DGND}$		0.85	1.5	mA
IOI_{DD}	$V_{IH} = IOV_{DD}$, $V_{IL} = \text{DGND}$		1	10	μA
AI_{DD} power-down	PDN pin = IOV_{DD}		25	50	μA
Power dissipation	$AV_{DD} = 5\text{ V}$		4.3	7.5	mW

6.6 Electrical Characteristics: $AV_{DD} = 2.7\text{ V}$

all specifications at $T_A = T_{MIN}$ to T_{MAX} , $AV_{DD} = 2.7\text{ V}$ to 3.3 V , $IOV_{DD} = 1.8\text{ V}$ to AV_{DD} , $V_{REFH} = 2.5\text{ V}$, $V_{REFL} = 0\text{ V}$ and gain = 1X mode (unless otherwise noted)

PARAMETER	TEST CONDITIONS		MIN	TYP	MAX	UNIT
ACCURACY⁽¹⁾						
Integral linearity error	Measured by line passing through codes 2048 and 262143	DAC9881S		±2.5	±3.5	LSB
		DAC9881SB		±2	±3	LSB
Differential linearity error	Measured by line passing through codes 2048 and 262143	DAC9881S		±1	±2	LSB
		DAC9881SB		±0.75	±1.5	LSB
Zero-scale error	$T_A = 25^\circ\text{C}$, code = 2048				±32	LSB
	T_{MIN} to T_{MAX} , code = 2048				±64	LSB
Zero-scale drift ⁽²⁾	Code = 2048			±0.5	±1.6	ppm/°C of FSR
Gain error	$T_A = 25^\circ\text{C}$, measured by line passing through codes 2048 and 262143			±32	±64	LSB
Gain temperature drift ⁽²⁾	Measured by line passing through codes 2048 and 262143			±0.5	±0.8	ppm/°C
PSRR ⁽²⁾	$V_{OUT} = \text{full-scale}$, $AV_{DD} = 3\text{ V} \pm 10\%$				64	LSB/V
ANALOG OUTPUT⁽²⁾						
Voltage output ⁽³⁾			0		AV_{DD}	V
Output voltage drift vs time	Device operating for 500 hours at 25°C			0.2		ppm of FSR
	Device operating for 1000 hours at 25°C			0.4		ppm of FSR
Output current ⁽⁴⁾				2.5		mA
Maximum load capacitance				200		pF
Short-circuit current				31–50		mA
REFERENCE INPUT⁽²⁾						
V_{REFH} input voltage range	$AV_{DD} = 3\text{ V}$		1.25	2.5	AV_{DD}	V
V_{REFH} input capacitance				5		pF
V_{REFH} input impedance				4.5		kΩ
V_{REFL} input voltage range			-0.2	0	0.2	V
V_{REFL} input capacitance				4.5		pF
V_{REFL} input impedance				5		kΩ
DYNAMIC PERFORMANCE⁽²⁾						
Settling time	To ±0.003% FS, $R_L = 10\text{ k}\Omega$, $C_L = 50\text{ pF}$, code 04000h to 3C000h			5		μs
Slew rate	From 10% to 90% of 0 V to 2.5 V			2.5		V/μs
Code change glitch	Code = 1FFFFh to 20000h to 1FFFFh	$V_{REFH} = 2.5\text{ V}$, gain = 1X mode		18		nV-s
		$V_{REFH} = 1.25\text{ V}$, gain = 1X mode		9		nV-s
		$V_{REFH} = 1.25\text{ V}$, gain = 2X mode		10		nV-s
Digital feedthrough	$\overline{CS} = \text{high}$, $f_{SCLK} = 1\text{ kHz}$			1		nV-s
Output noise voltage density	$f = 1\text{ kHz}$ to 100 kHz , full-scale output	Gain = 1		24	30	$\text{nV}/\sqrt{\text{Hz}}$
		Gain = 2		40	48	$\text{nV}/\sqrt{\text{Hz}}$
Output noise voltage	$f = 0.1\text{ Hz}$ to 10 Hz , full-scale output			2		μV _{PP}

(1) DAC output range is 0 V to 2.5 V. 1 LSB = 9.5 μV.

(2) Specified by design; not production tested.

(3) The output from the V_{OUT} pin is $[(V_{REFH} - V_{REFL}) / 262144] \times \text{CODE} \times \text{Buffer GAIN} + V_{REFL}$. The maximum range of V_{OUT} is 0 V to AV_{DD} . The full-scale of the output must be less than AV_{DD} ; otherwise, output saturation occurs.

(4) See [Figure 55](#), [Figure 56](#), and [Figure 57](#) for details.

Electrical Characteristics: AV_{DD} = 2.7 V (continued)

all specifications at T_A = T_{MIN} to T_{MAX}, AV_{DD} = 2.7 V to 3.3 V, IOV_{DD} = 1.8 V to AV_{DD}, V_{REFH} = 2.5 V, V_{REFL} = 0 V and gain = 1X mode (unless otherwise noted)

PARAMETER	TEST CONDITIONS	MIN	TYP	MAX	UNIT
DIGITAL INPUTS⁽²⁾					
High-level input voltage, V _{IH}	IOV _{DD} = 2.7 V to 3.3 V	2.1		IOV _{DD} + 0.3	V
	IOV _{DD} = 1.7 V to 2 V	1.5		IOV _{DD} + 0.3	V
Low-level input voltage, V _{IL}	IOV _{DD} = 2.7 V to 3.3 V	-0.3		0.6	V
	IOV _{DD} = 1.7 V to 2 V	-0.3		0.3	V
Digital input current (I _{IN})			±1	±10	µA
Digital input capacitance			5		pF
DIGITAL OUTPUT⁽²⁾					
High-level output voltage, V _{OH}	IOV _{DD} = 2.7 V to 3.3 V, I _{OH} = -1 mA	IOV _{DD} - 0.2			V
	IOV _{DD} = 1.7 V to 2 V, I _{OH} = -500 µA	IOV _{DD} - 0.2			V
Low-level output voltage, V _{OL}	IOV _{DD} = 2.7 V to 3.3 V, I _{OL} = 1 mA			0.2	V
	IOV _{DD} = 1.7 to 2 V, I _{OL} = 500 µA			0.2	V
POWER SUPPLY					
AV _{DD}		2.7	3	3.3	V
IOV _{DD}		1.7		AV _{DD}	V
AI _{DD}	V _{IH} = IOV _{DD} , V _{IL} = DGND		0.75	1.2	mA
IOI _{DD}	V _{IH} = IOV _{DD} , V _{IL} = DGND		1	10	µA
AI _{DD} power-down	PDN pin = IOV _{DD}		25	50	µA
Power dissipation	AV _{DD} = 3 V		2.3	3.6	mW

6.7 Timing Requirements—Standalone Operation Without SDO

 at -40°C to $+105^{\circ}\text{C}$ (unless otherwise noted); see Figure 1⁽¹⁾⁽²⁾⁽³⁾

			MIN	MAX	UNIT
f _{SCLK}	Maximum clock frequency	$2.7 \leq AV_{DD} < 3.6 \text{ V}, 2.7 \leq IOV_{DD} \leq AV_{DD}$		40	MHz
		$3.6 \leq AV_{DD} \leq 5.5 \text{ V}, 2.7 \leq IOV_{DD} \leq AV_{DD}$		50	MHz
t ₁	Minimum \overline{CS} high time	$2.7 \leq AV_{DD} < 3.6 \text{ V}, 2.7 \leq IOV_{DD} \leq AV_{DD}$	50		ns
		$3.6 \leq AV_{DD} \leq 5.5 \text{ V}, 2.7 \leq IOV_{DD} \leq AV_{DD}$	30		ns
t ₂	Delay from \overline{CS} falling edge to SCLK rising edge	$2.7 \leq AV_{DD} < 3.6 \text{ V}, 2.7 \leq IOV_{DD} \leq AV_{DD}$	10		ns
		$3.6 \leq AV_{DD} \leq 5.5 \text{ V}, 2.7 \leq IOV_{DD} \leq AV_{DD}$	8		ns
t ₃	Delay from SCLK falling edge to \overline{CS} falling edge	$2.7 \leq AV_{DD} < 3.6 \text{ V}, 2.7 \leq IOV_{DD} \leq AV_{DD}$	0		ns
		$3.6 \leq AV_{DD} \leq 5.5 \text{ V}, 2.7 \leq IOV_{DD} \leq AV_{DD}$	0		ns
t ₄	SCLK low time	$2.7 \leq AV_{DD} < 3.6 \text{ V}, 2.7 \leq IOV_{DD} \leq AV_{DD}$	10		ns
		$3.6 \leq AV_{DD} \leq 5.5 \text{ V}, 2.7 \leq IOV_{DD} \leq AV_{DD}$	10		ns
t ₅	SCLK high time	$2.7 \leq AV_{DD} < 3.6 \text{ V}, 2.7 \leq IOV_{DD} \leq AV_{DD}$	15		ns
		$3.6 \leq AV_{DD} \leq 5.5 \text{ V}, 2.7 \leq IOV_{DD} \leq AV_{DD}$	10		ns
t ₆	SCLK cycle time	$2.7 \leq AV_{DD} < 3.6 \text{ V}, 2.7 \leq IOV_{DD} \leq AV_{DD}$	25		ns
		$3.6 \leq AV_{DD} \leq 5.5 \text{ V}, 2.7 \leq IOV_{DD} \leq AV_{DD}$	20		ns
t ₇	Delay from SCLK rising edge to \overline{CS} rising edge	$2.7 \leq AV_{DD} < 3.6 \text{ V}, 2.7 \leq IOV_{DD} \leq AV_{DD}$	10		ns
		$3.6 \leq AV_{DD} \leq 5.5 \text{ V}, 2.7 \leq IOV_{DD} \leq AV_{DD}$	10		ns
t ₈	Input data setup time	$2.7 \leq AV_{DD} < 3.6 \text{ V}, 2.7 \leq IOV_{DD} \leq AV_{DD}$	8		ns
		$3.6 \leq AV_{DD} \leq 5.5 \text{ V}, 2.7 \leq IOV_{DD} \leq AV_{DD}$	5		ns
t ₉	Input data hold time	$2.7 \leq AV_{DD} < 3.6 \text{ V}, 2.7 \leq IOV_{DD} \leq AV_{DD}$	5		ns
		$3.6 \leq AV_{DD} \leq 5.5 \text{ V}, 2.7 \leq IOV_{DD} \leq AV_{DD}$	5		ns
t ₁₄	Delay from \overline{CS} rising edge to \overline{LDAC} falling edge	$2.7 \leq AV_{DD} < 3.6 \text{ V}, 2.7 \leq IOV_{DD} \leq AV_{DD}$	10		ns
		$3.6 \leq AV_{DD} \leq 5.5 \text{ V}, 2.7 \leq IOV_{DD} \leq AV_{DD}$	5		ns
t ₁₅	\overline{LDAC} pulse duration	$2.7 \leq AV_{DD} < 3.6 \text{ V}, 2.7 \leq IOV_{DD} \leq AV_{DD}$	15		ns
		$3.6 \leq AV_{DD} \leq 5.5 \text{ V}, 2.7 \leq IOV_{DD} \leq AV_{DD}$	10		ns

- (1) All input signals are specified with $t_R = t_F = 2\text{ns}$ (10% to 90% of IOV_{DD}) and timed from a voltage level of $IOV_{DD} / 2$.
- (2) Specified by design; not production tested.
- (3) Sample tested during the initial release and after any redesign or process changes that may affect these parameters.

6.8 Timing Requirements—Standalone Operation With SDO and Daisy-Chain Mode

at -40°C to $+105^{\circ}\text{C}$ (unless otherwise noted); see [Figure 2](#) and [Figure 3](#) ⁽¹⁾⁽²⁾⁽³⁾

			MIN	MAX	UNIT
f _{SCLK}	Maximum clock frequency	$2.7 \leq AV_{DD} < 3.6 \text{ V}, 2.7 \leq IOV_{DD} \leq AV_{DD}$		20	MHz
		$3.6 \leq AV_{DD} \leq 5.5 \text{ V}, 2.7 \leq IOV_{DD} \leq AV_{DD}$		25	MHz
t ₁	Minimum \overline{CS} high time	$2.7 \leq AV_{DD} < 3.6 \text{ V}, 2.7 \leq IOV_{DD} \leq AV_{DD}$	50		ns
		$3.6 \leq AV_{DD} \leq 5.5 \text{ V}, 2.7 \leq IOV_{DD} \leq AV_{DD}$	30		ns
t ₂	Delay from \overline{CS} falling edge to SCLK rising edge	$2.7 \leq AV_{DD} < 3.6 \text{ V}, 2.7 \leq IOV_{DD} \leq AV_{DD}$	10		ns
		$3.6 \leq AV_{DD} \leq 5.5 \text{ V}, 2.7 \leq IOV_{DD} \leq AV_{DD}$	8		ns
t ₃	Delay from SCLK falling edge to \overline{CS} falling edge	$2.7 \leq AV_{DD} < 3.6 \text{ V}, 2.7 \leq IOV_{DD} \leq AV_{DD}$	0		ns
		$3.6 \leq AV_{DD} \leq 5.5 \text{ V}, 2.7 \leq IOV_{DD} \leq AV_{DD}$	0		ns
t ₄	SCLK low time	$2.7 \leq AV_{DD} < 3.6 \text{ V}, 2.7 \leq IOV_{DD} \leq AV_{DD}$	25		ns
		$3.6 \leq AV_{DD} \leq 5.5 \text{ V}, 2.7 \leq IOV_{DD} \leq AV_{DD}$	20		ns
t ₅	SCLK high time	$2.7 \leq AV_{DD} < 3.6 \text{ V}, 2.7 \leq IOV_{DD} \leq AV_{DD}$	25		ns
		$3.6 \leq AV_{DD} \leq 5.5 \text{ V}, 2.7 \leq IOV_{DD} \leq AV_{DD}$	20		ns
t ₆	SCLK cycle time	$2.7 \leq AV_{DD} < 3.6 \text{ V}, 2.7 \leq IOV_{DD} \leq AV_{DD}$	50		ns
		$3.6 \leq AV_{DD} \leq 5.5 \text{ V}, 2.7 \leq IOV_{DD} \leq AV_{DD}$	40		ns
t ₇	Delay from SCLK rising edge to \overline{CS} rising edge	$2.7 \leq AV_{DD} < 3.6 \text{ V}, 2.7 \leq IOV_{DD} \leq AV_{DD}$	10		ns
		$3.6 \leq AV_{DD} \leq 5.5 \text{ V}, 2.7 \leq IOV_{DD} \leq AV_{DD}$	10		ns
t ₈	Input data setup time	$2.7 \leq AV_{DD} < 3.6 \text{ V}, 2.7 \leq IOV_{DD} \leq AV_{DD}$	5		ns
		$3.6 \leq AV_{DD} \leq 5.5 \text{ V}, 2.7 \leq IOV_{DD} \leq AV_{DD}$	5		ns
t ₉	Input data hold time	$2.7 \leq AV_{DD} < 3.6 \text{ V}, 2.7 \leq IOV_{DD} \leq AV_{DD}$	5		ns
		$3.6 \leq AV_{DD} \leq 5.5 \text{ V}, 2.7 \leq IOV_{DD} \leq AV_{DD}$	5		ns
t ₁₀	Delay from \overline{CS} falling edge to SDO valid	$2.7 \leq AV_{DD} < 3.6 \text{ V}, 2.7 \leq IOV_{DD} \leq AV_{DD}$		15	ns
		$3.6 \leq AV_{DD} \leq 5.5 \text{ V}, 2.7 \leq IOV_{DD} \leq AV_{DD}$		10	ns
t ₁₁	Delay from SCLK falling edge to SDO valid	$2.7 \leq AV_{DD} < 3.6 \text{ V}, 2.7 \leq IOV_{DD} \leq AV_{DD}$		20	ns
		$3.6 \leq AV_{DD} \leq 5.5 \text{ V}, 2.7 \leq IOV_{DD} \leq AV_{DD}$		15	ns
t ₁₂	SDO data hold from SCLK rising edge	$2.7 \leq AV_{DD} < 3.6 \text{ V}, 2.7 \leq IOV_{DD} \leq AV_{DD}$	t ₅		ns
		$3.6 \leq AV_{DD} \leq 5.5 \text{ V}, 2.7 \leq IOV_{DD} \leq AV_{DD}$	t ₅		ns
t ₁₃	Delay from \overline{CS} rising edge to SDO high-Z	$2.7 \leq AV_{DD} < 3.6 \text{ V}, 2.7 \leq IOV_{DD} \leq AV_{DD}$		8	ns
		$3.6 \leq AV_{DD} \leq 5.5 \text{ V}, 2.7 \leq IOV_{DD} \leq AV_{DD}$		5	ns
t ₁₄	Delay from \overline{CS} rising edge to \overline{LDAC} falling edge	$2.7 \leq AV_{DD} < 3.6 \text{ V}, 2.7 \leq IOV_{DD} \leq AV_{DD}$	10		ns
		$3.6 \leq AV_{DD} \leq 5.5 \text{ V}, 2.7 \leq IOV_{DD} \leq AV_{DD}$	5		ns
t ₁₅	\overline{LDAC} pulse width	$2.7 \leq AV_{DD} < 3.6 \text{ V}, 2.7 \leq IOV_{DD} \leq AV_{DD}$	15		ns
		$3.6 \leq AV_{DD} \leq 5.5 \text{ V}, 2.7 \leq IOV_{DD} \leq AV_{DD}$	10		ns

(1) All input signals are specified with $t_R = t_F = 2\text{ns}$ (10% to 90% of IOV_{DD}) and timed from a voltage level of $IOV_{DD} / 2$.

(2) Specified by design; not production tested.

(3) Sample tested during the initial release and after any redesign or process changes that may affect these parameters.

Case 1: Standalone operation without SDO, $\overline{\text{LDAC}}$ tied low.

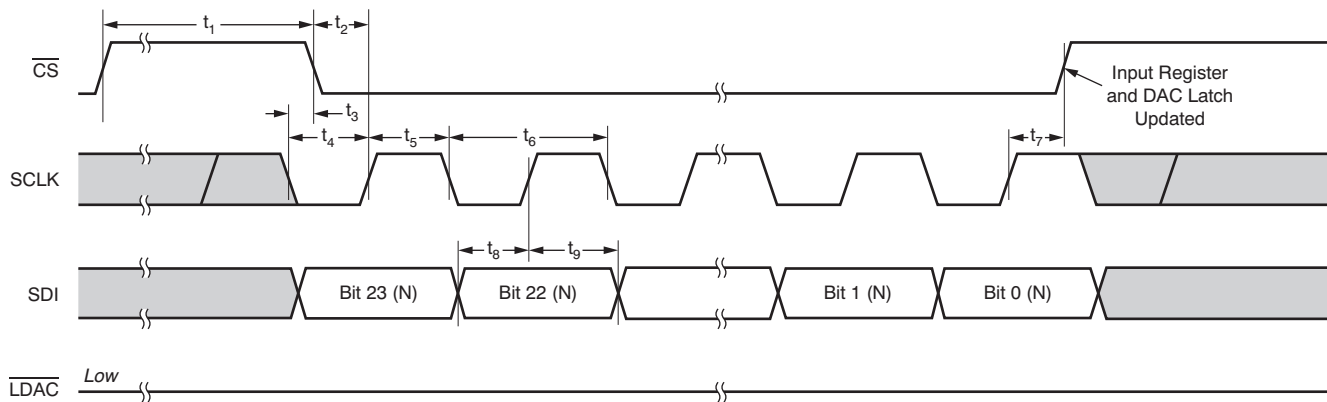

Case 2: Standalone operation without SDO, $\overline{\text{LDAC}}$ active.

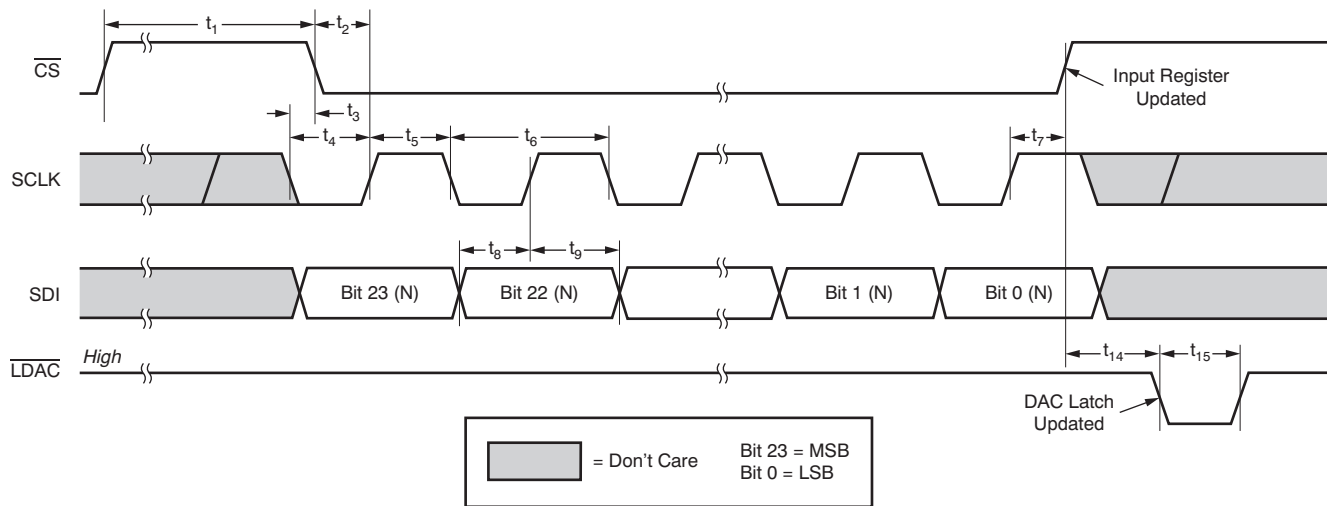
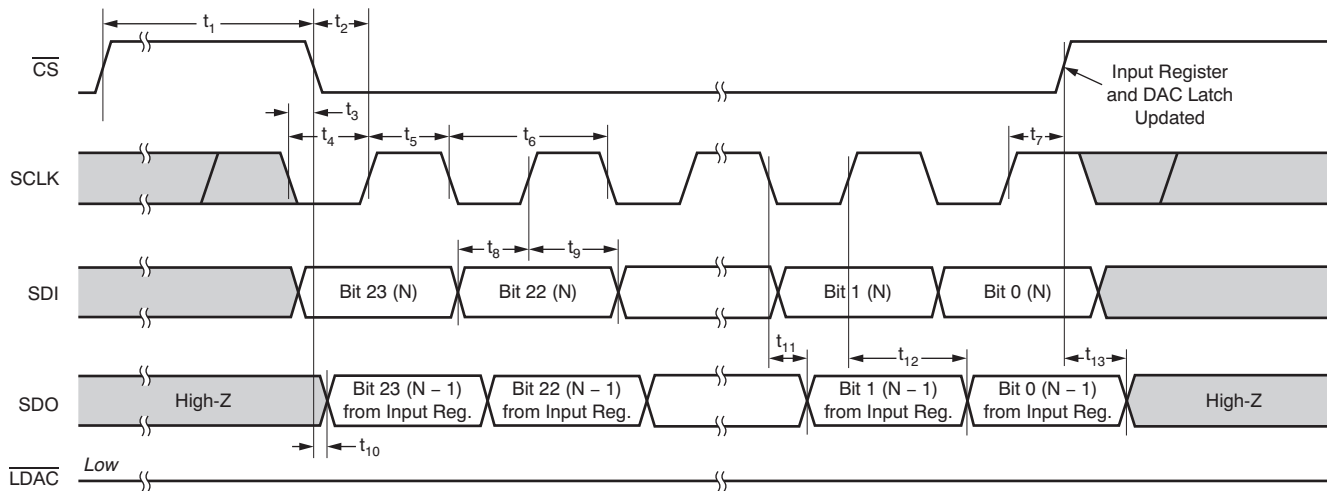

Figure 1. Timing Diagram for Standalone Operation Without SDO

Case 1: Standalone operation with output from SDO, $\overline{\text{LDAC}}$ tied low.



Case 2: Standalone operation with output from SDO, $\overline{\text{LDAC}}$ active.

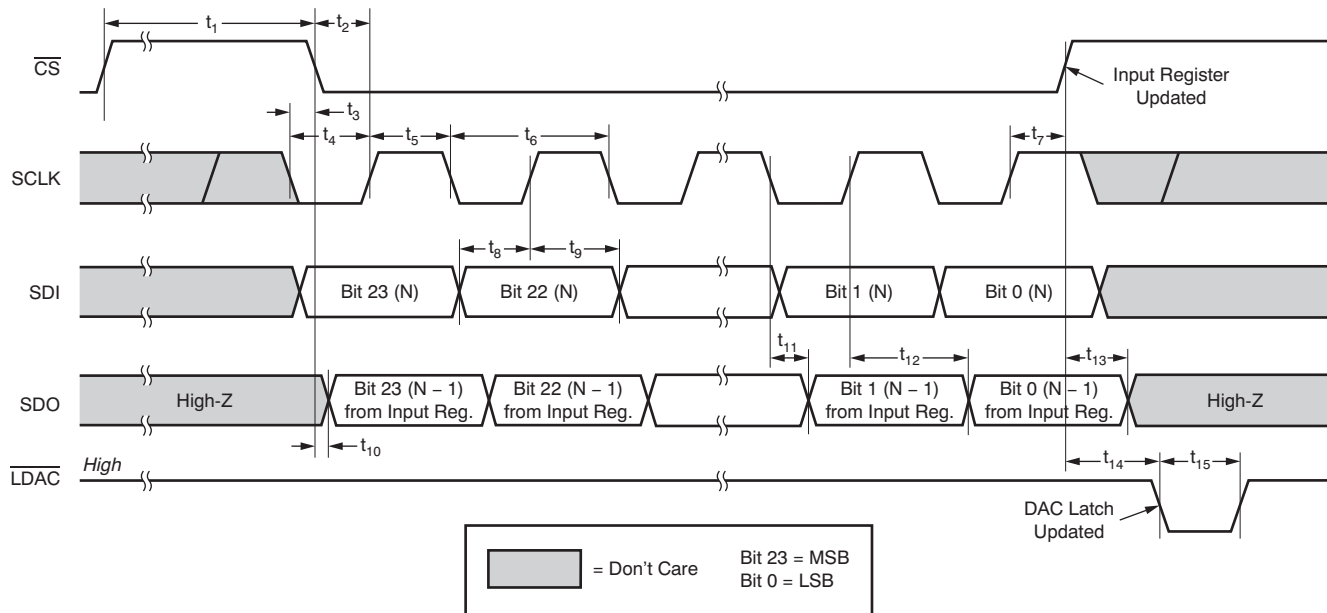

Figure 2. Timing Diagram for Standalone Operation With SDO

6.9 Typical Characteristics: $AV_{DD} = 5\text{ V}$

at $T_A = 25^\circ\text{C}$, $V_{REFH} = 5\text{ V}$, $V_{REFL} = 0\text{ V}$, and gain = 1X mode (unless otherwise noted)

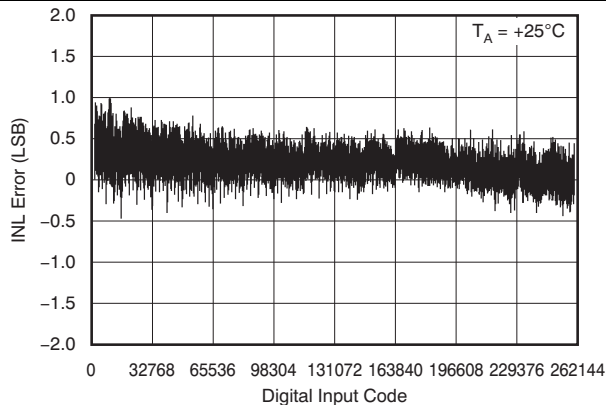

Figure 4. Linearity Error vs Digital Input Code

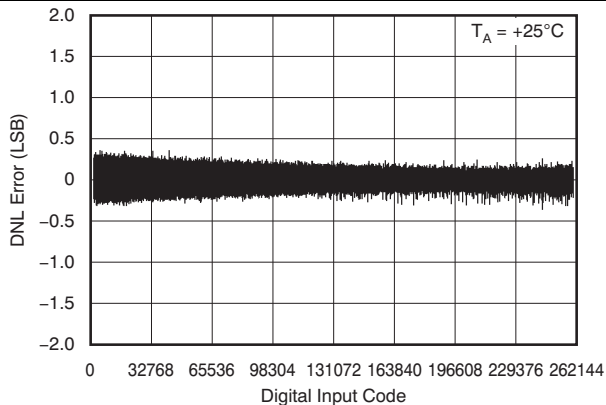

Figure 5. Differential Linearity Error vs Digital Input Code

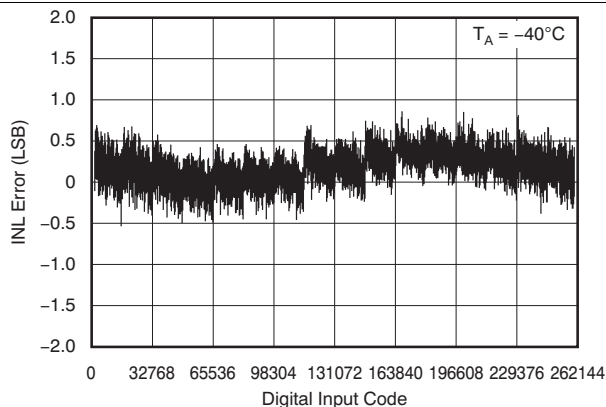

Figure 6. Linearity Error vs Digital Input Code

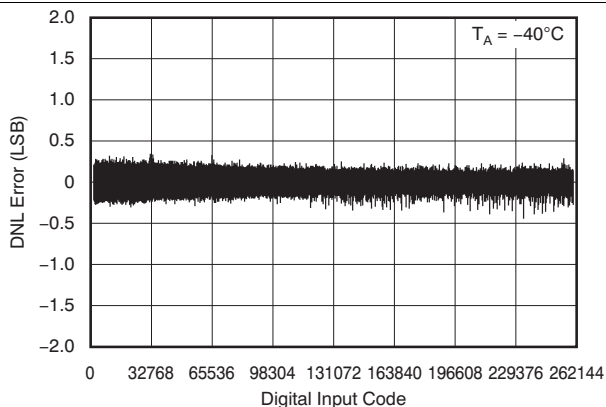

Figure 7. Differential Linearity Error vs Digital Input Code

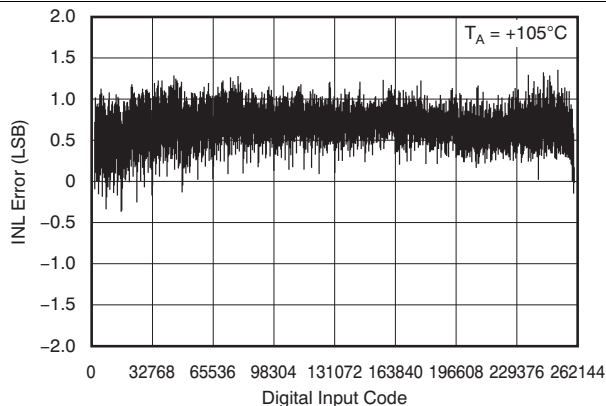

Figure 8. Linearity Error vs Digital Input Code

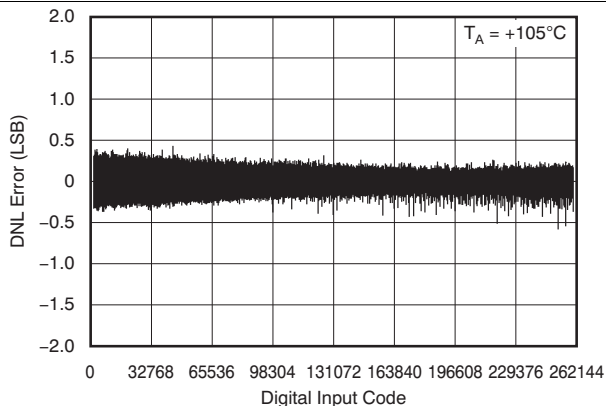

Figure 9. Differential Linearity Error vs Digital Input Code

Typical Characteristics: $AV_{DD} = 5\text{ V}$ (continued)

at $T_A = 25^\circ\text{C}$, $V_{REFH} = 5\text{ V}$, $V_{REFL} = 0\text{ V}$, and gain = 1X mode (unless otherwise noted)

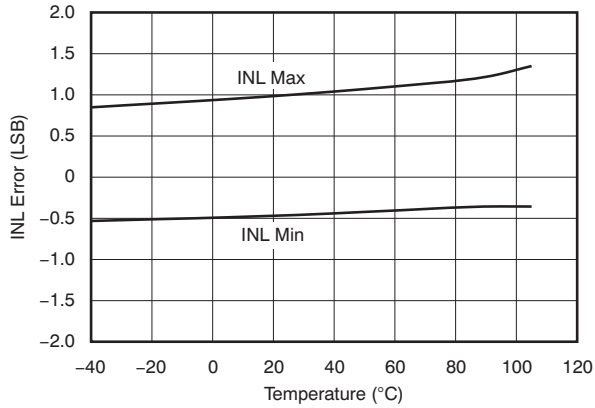

Figure 10. Linearity Error vs Temperature

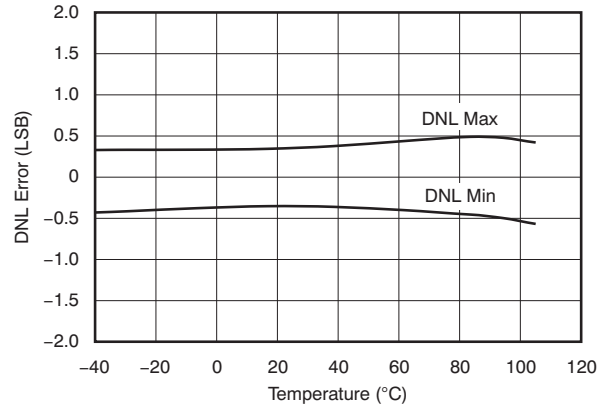

Figure 11. Differential Linearity Error vs Temperature

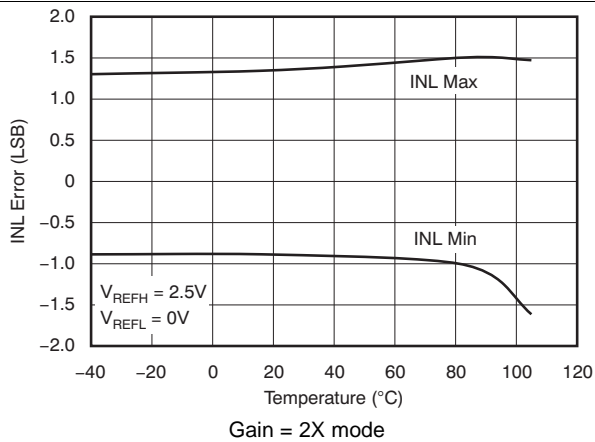

Figure 12. Linearity Error vs Temperature

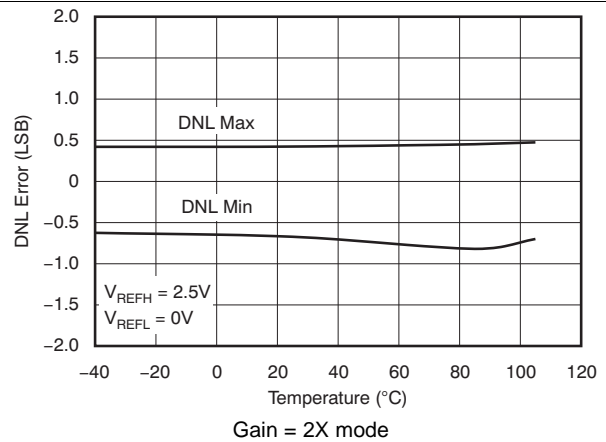

Figure 13. Differential Linearity Error vs Temperature

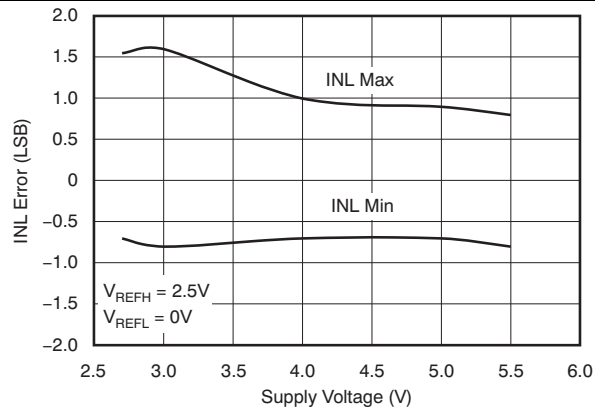

Figure 14. Linearity Error vs Supply Voltage

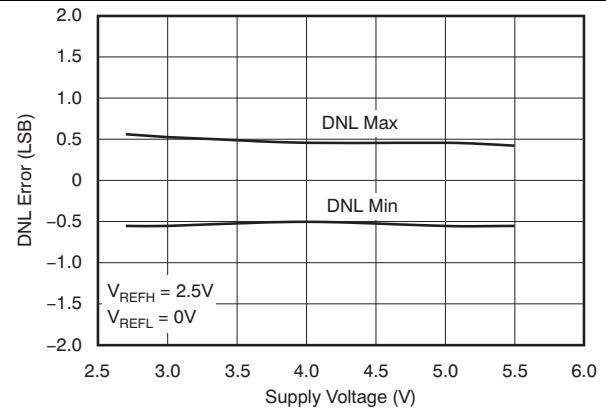

Figure 15. Differential Linearity Error vs Supply Voltage

Typical Characteristics: $A_{V_{DD}} = 5\text{ V}$ (continued)

at $T_A = 25^\circ\text{C}$, $V_{REFH} = 5\text{ V}$, $V_{REFL} = 0\text{ V}$, and gain = 1X mode (unless otherwise noted)

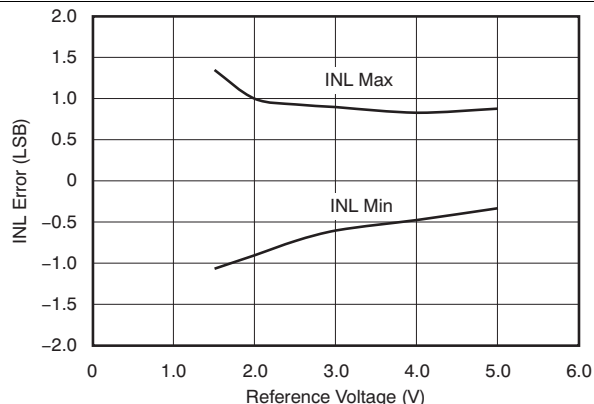

Figure 16. Linearity Error vs Reference Voltage

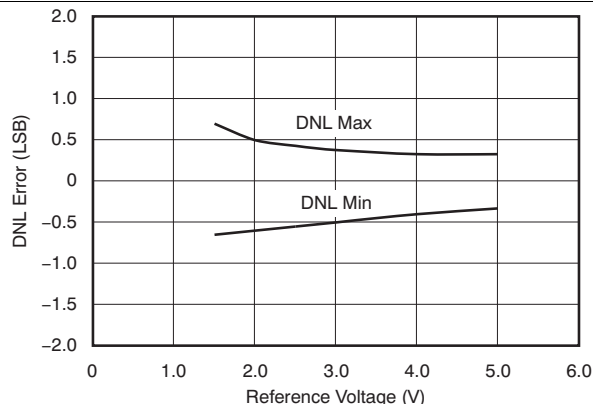

Figure 17. Differential Linearity Error vs Reference Voltage

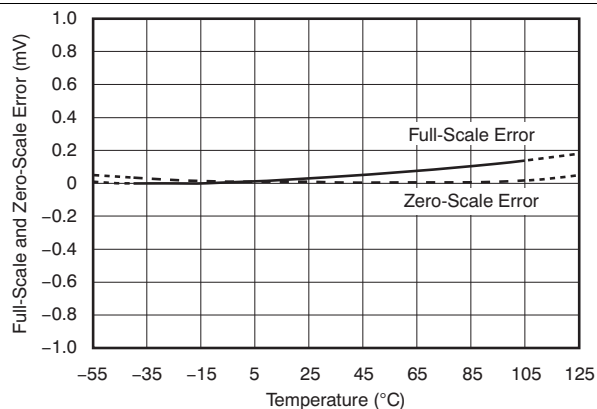

Figure 18. Full-Scale and Zero-Scale Error vs Temperature

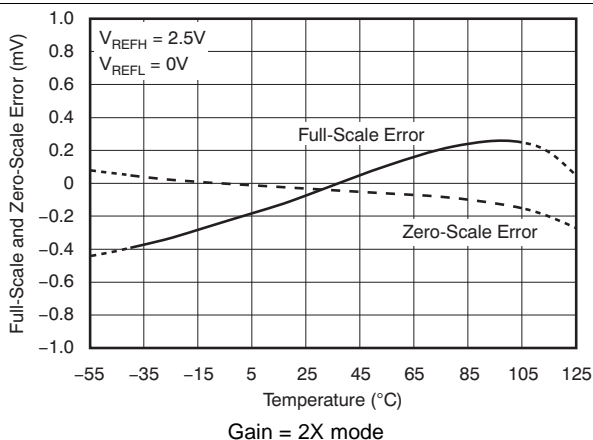

Figure 19. Full-Scale and Zero-Scale Error vs Temperature

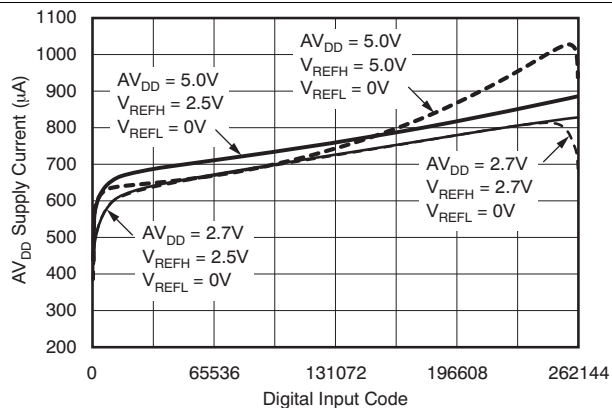

Figure 20. $A_{V_{DD}}$ Supply Current vs Digital Input Code

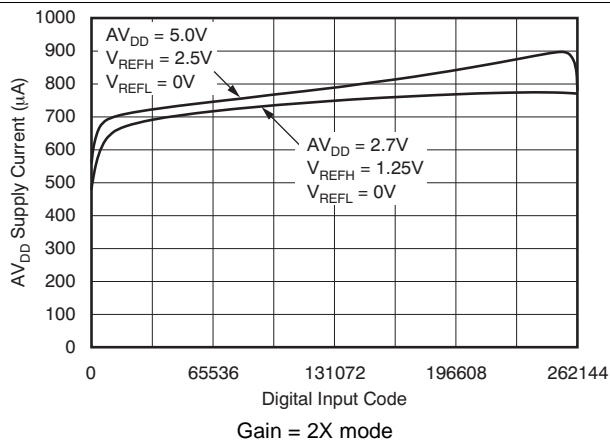

Figure 21. $A_{V_{DD}}$ Supply Current vs Digital Input Code

Typical Characteristics: AV_{DD} = 5 V (continued)

at T_A = 25°C, V_{REFH} = 5 V, V_{REFL} = 0 V, and gain = 1X mode (unless otherwise noted)

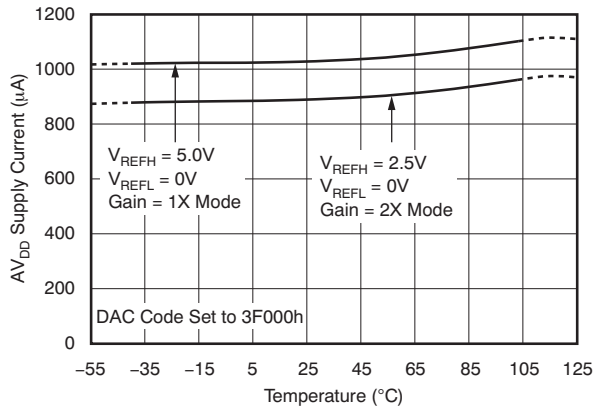

Figure 22. AVDD Supply Current vs Temperature

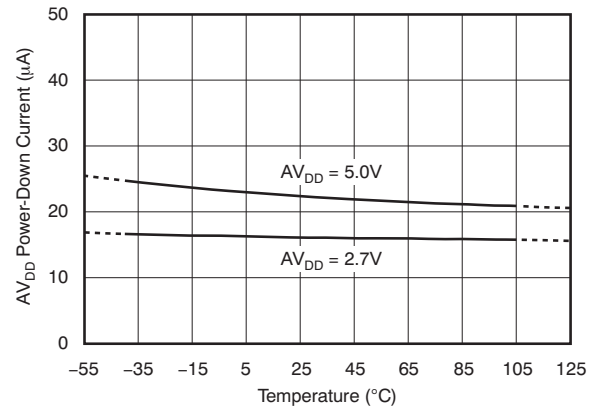

Figure 23. AVDD Power-Down Current vs Temperature

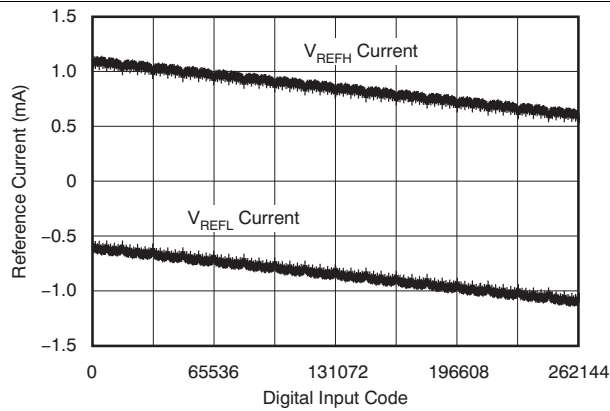

Figure 24. Reference Current vs Digital Input Code

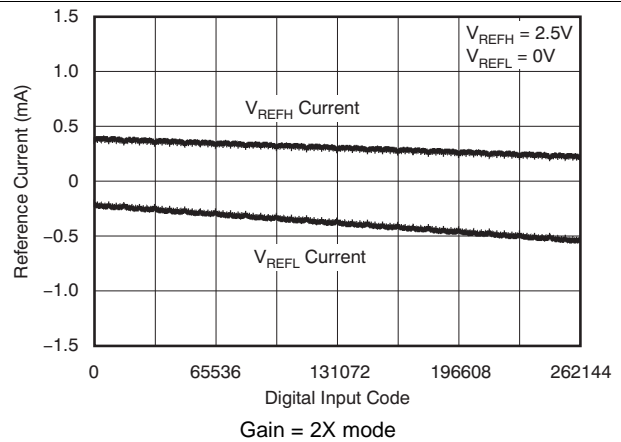

Figure 25. Reference Current vs Digital Input Code

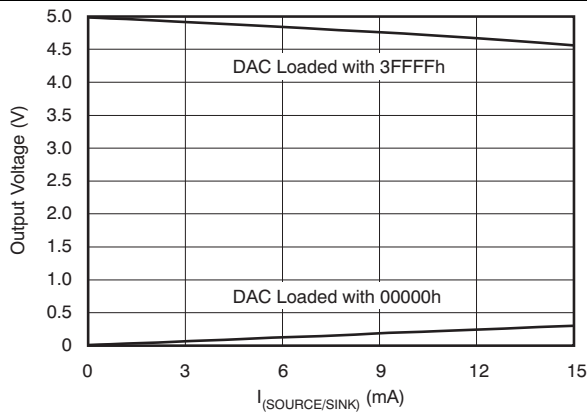

Figure 26. Output Voltage vs Drive Current Capability

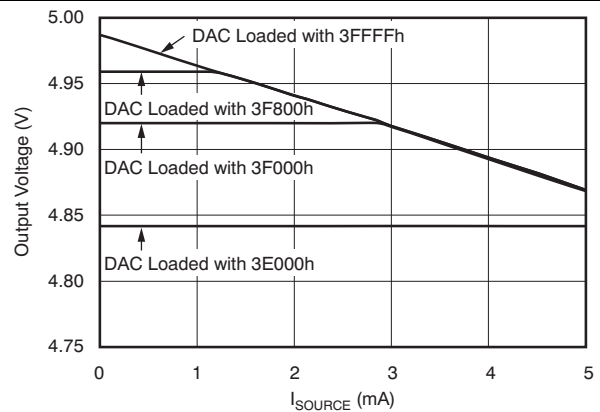

Figure 27. Output Voltage vs Drive Current Capability (Operation Near AV_{DD} Rail)

Typical Characteristics: AV_{DD} = 5 V (continued)

at T_A = 25°C, V_{REFH} = 5 V, V_{REFL} = 0 V, and gain = 1X mode (unless otherwise noted)

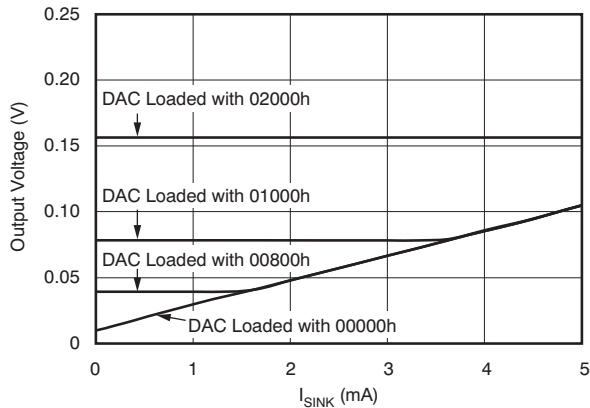

Figure 28. Output Voltage vs Drive Current Capability (Operation Near AGND Rail)

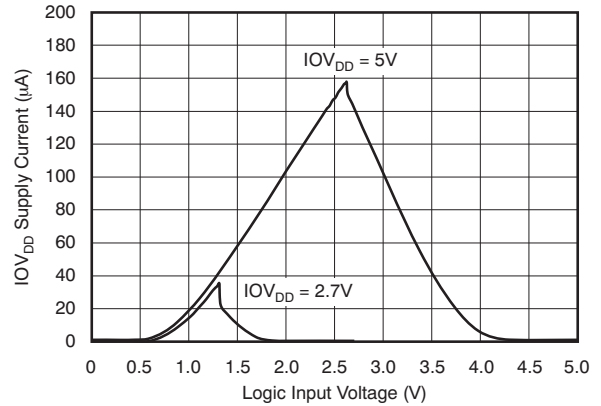

Figure 29. IOVDD Supply Current vs Logic Input Voltage

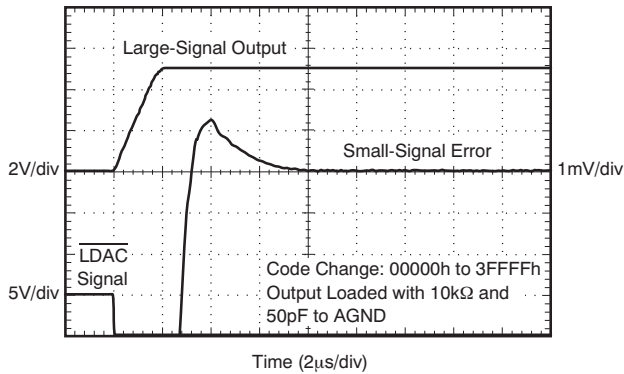

Figure 30. Large-Signal Settling Time

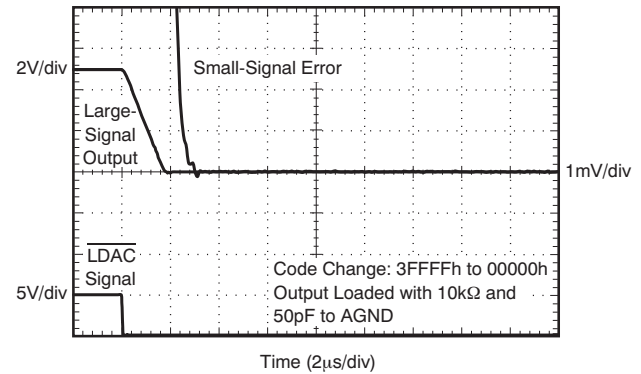

Figure 31. Large-Signal Settling Time

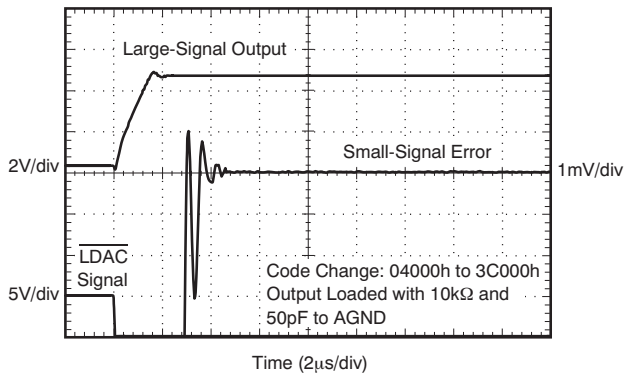

Figure 32. Large-Signal Settling Time

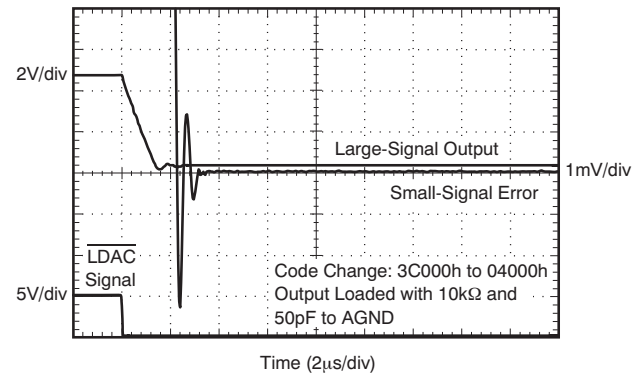
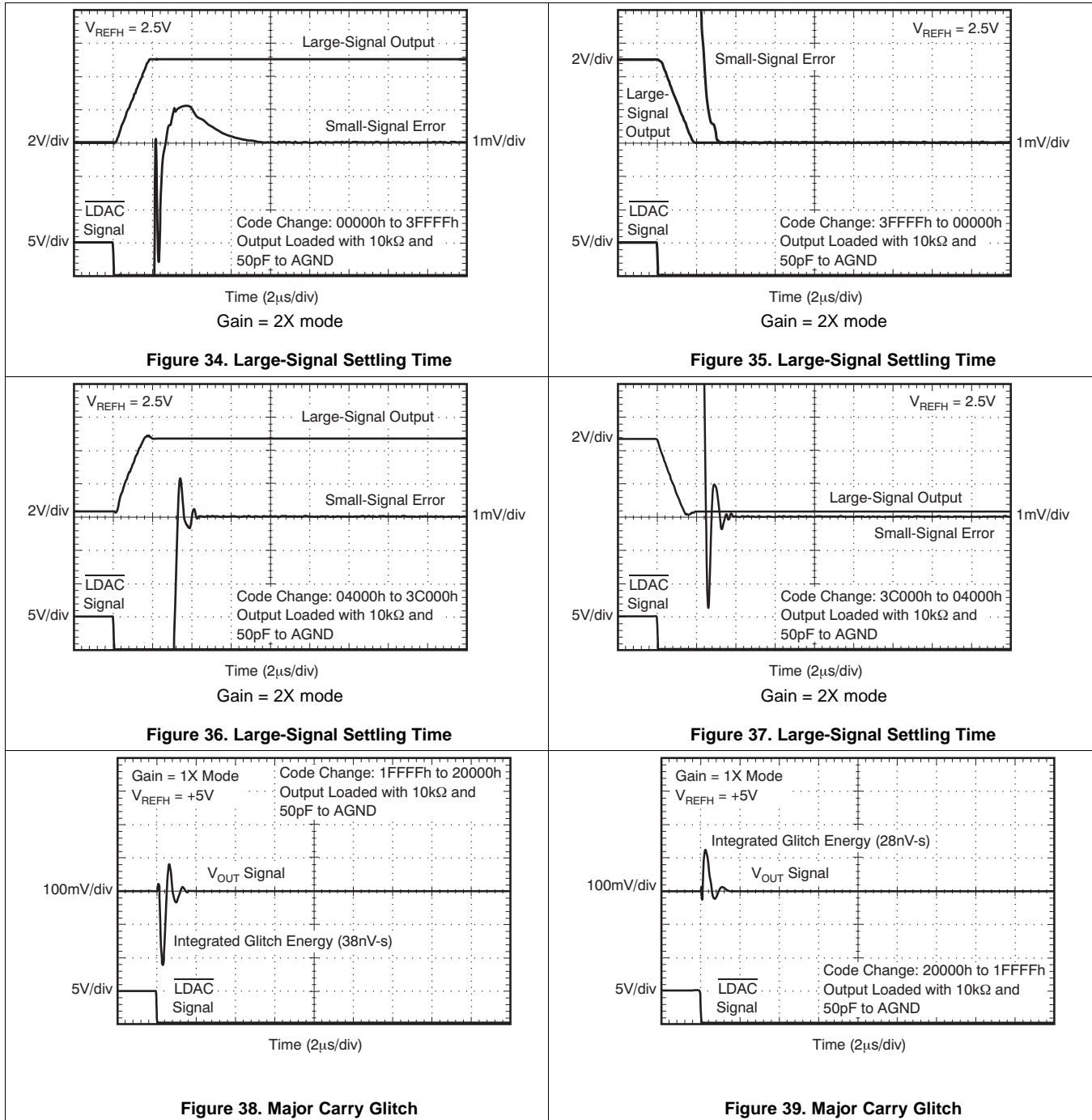

Figure 33. Large-Signal Settling Time

Typical Characteristics: $V_{DD} = 5\text{ V}$ (continued)

at $T_A = 25^\circ\text{C}$, $V_{REFH} = 5\text{ V}$, $V_{REFL} = 0\text{ V}$, and gain = 1X mode (unless otherwise noted)



Typical Characteristics: AV_{DD} = 5 V (continued)

at T_A = 25°C, V_{REFH} = 5 V, V_{REFL} = 0 V, and gain = 1X mode (unless otherwise noted)

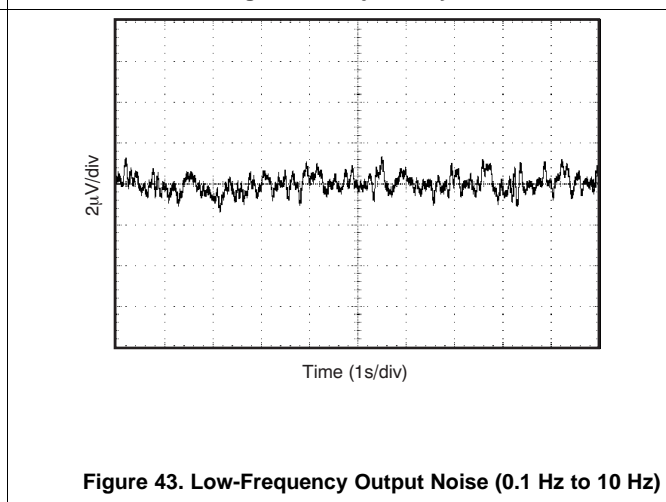
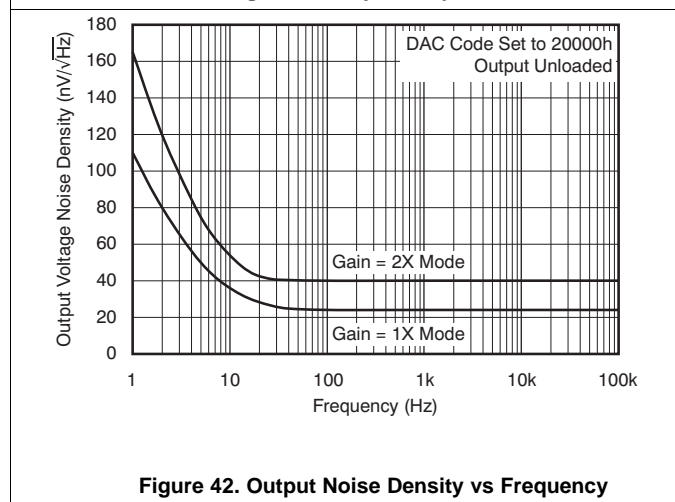
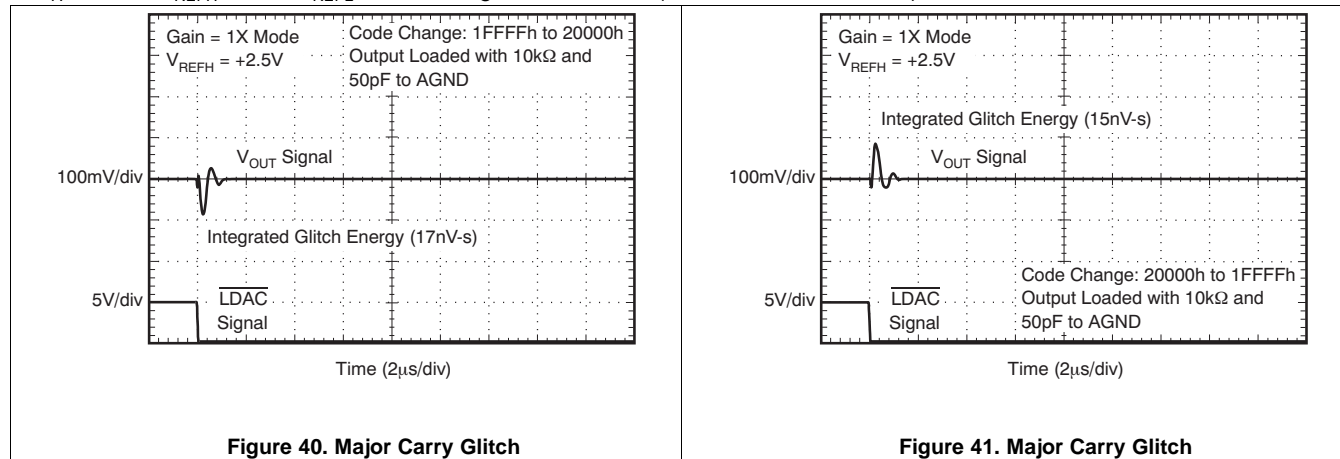

6.10 Typical Characteristics: $AV_{DD} = 2.7\text{ V}$

at $T_A = 25^\circ\text{C}$, $V_{REFH} = 2.5\text{ V}$, $V_{REFL} = 0\text{ V}$, and gain = 1X mode (unless otherwise noted)

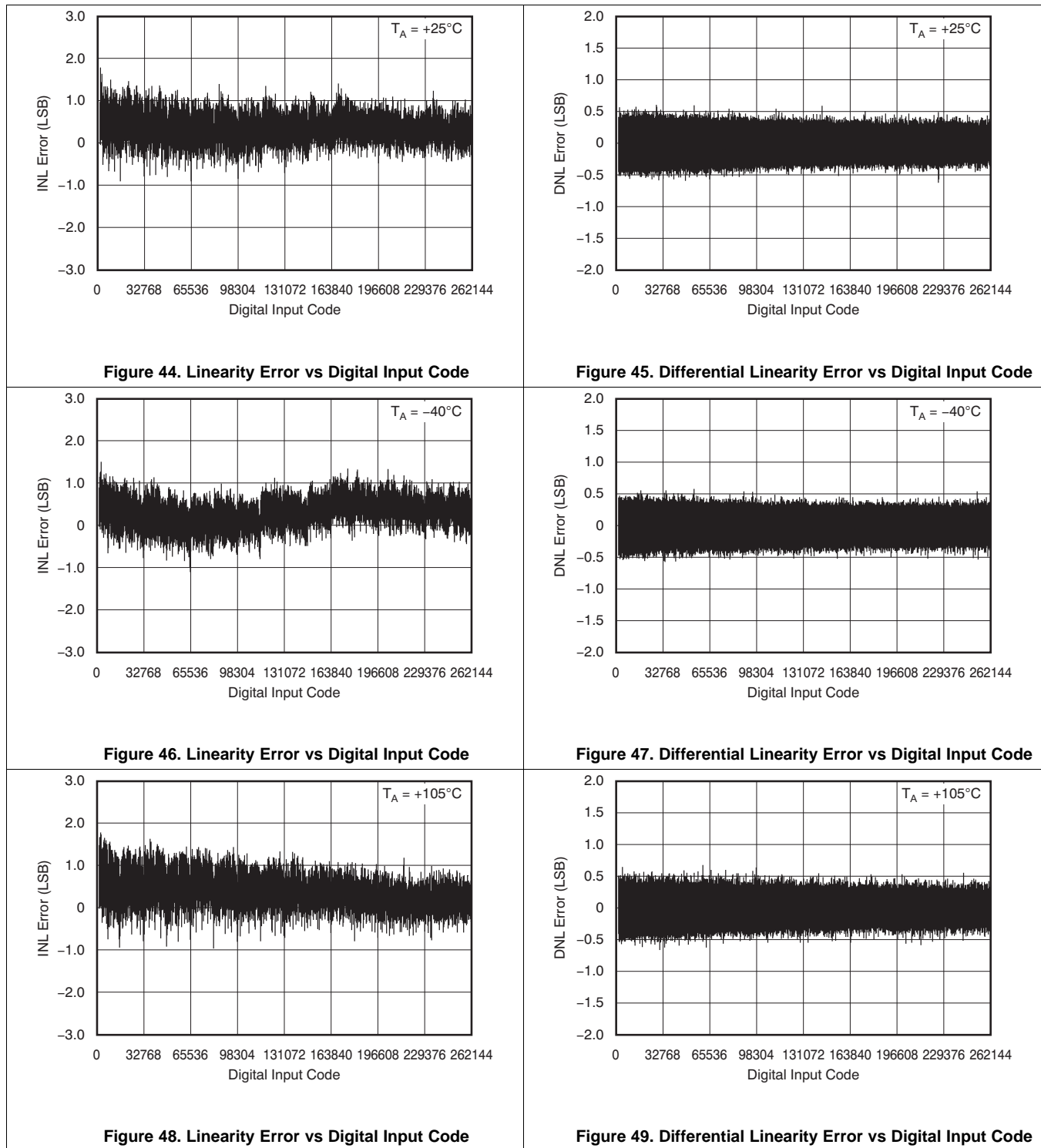

Typical Characteristics: AV_{DD} = 2.7 V (continued)

at T_A = 25°C, V_{REFH} = 2.5 V, V_{REFL} = 0 V, and gain = 1X mode (unless otherwise noted)

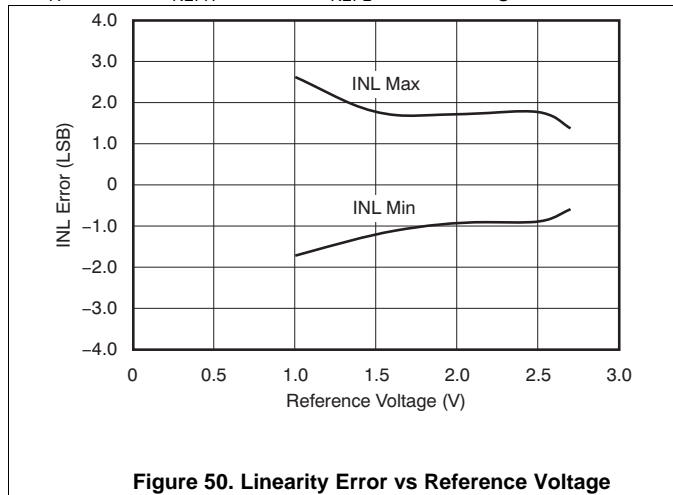

Figure 50. Linearity Error vs Reference Voltage

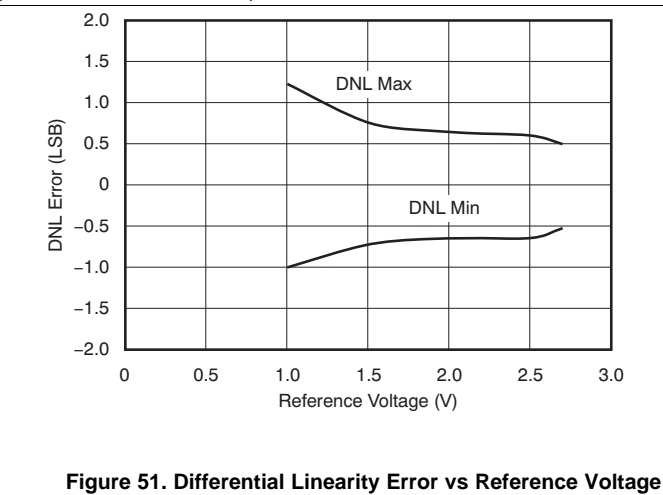

Figure 51. Differential Linearity Error vs Reference Voltage

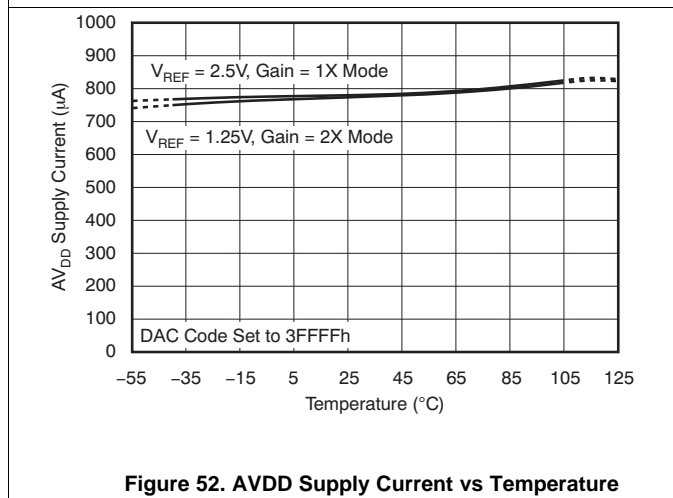

Figure 52. AVDD Supply Current vs Temperature

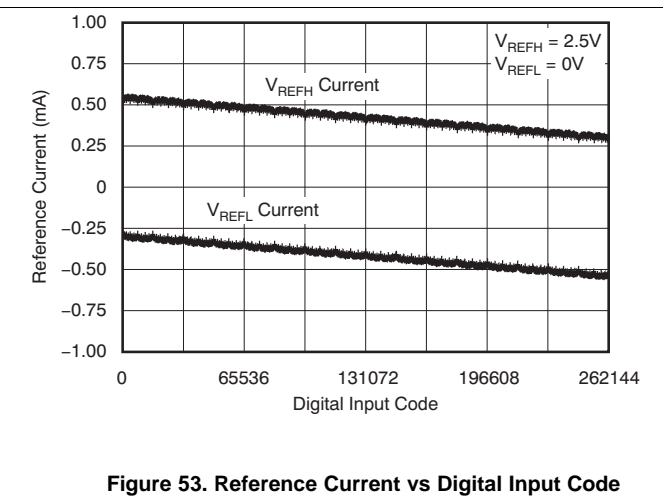

Figure 53. Reference Current vs Digital Input Code

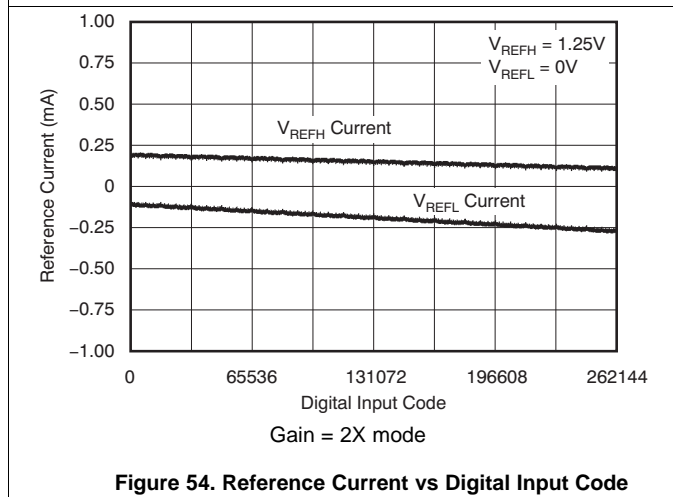

Figure 54. Reference Current vs Digital Input Code

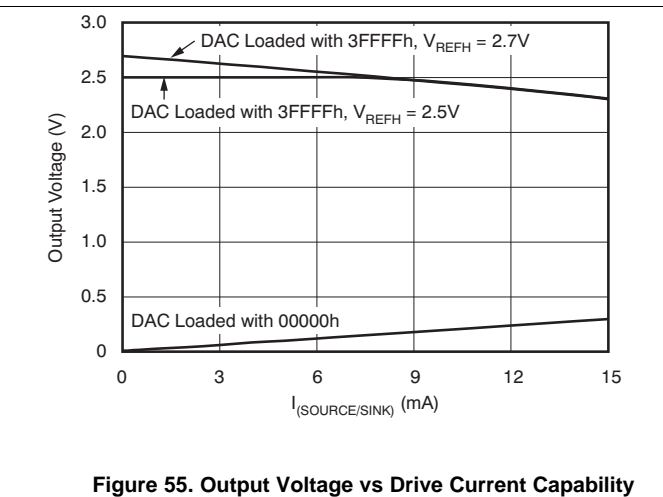

Figure 55. Output Voltage vs Drive Current Capability

Typical Characteristics: $AV_{DD} = 2.7\text{ V}$ (continued)

at $T_A = 25^\circ\text{C}$, $V_{REFH} = 2.5\text{ V}$, $V_{REFL} = 0\text{ V}$, and gain = 1X mode (unless otherwise noted)

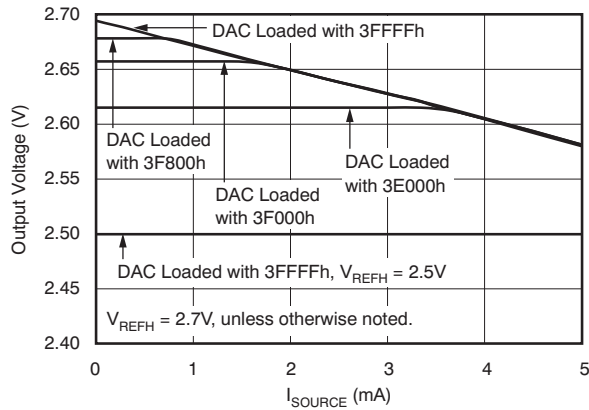

Figure 56. Output Voltage vs Drive Current Capability (Operation Near AV_{DD} Rail)

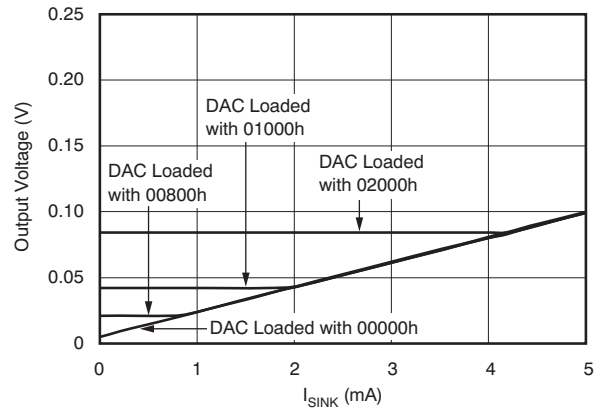

Figure 57. Output Voltage vs Drive Current Capability (Operation Near AGND Rail)

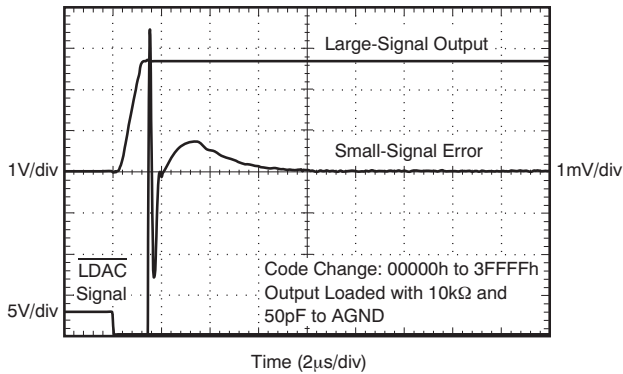

Figure 58. Large-Signal Settling Time

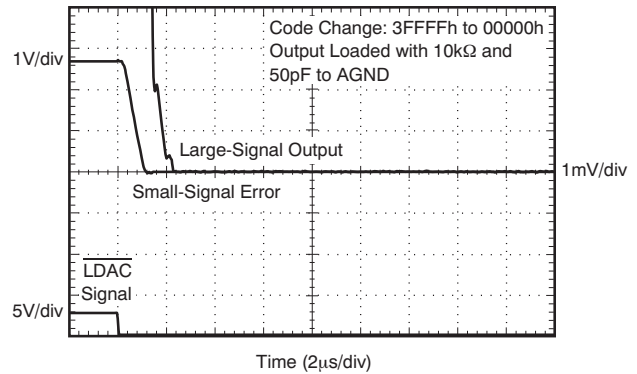

Figure 59. Large-Signal Settling Time

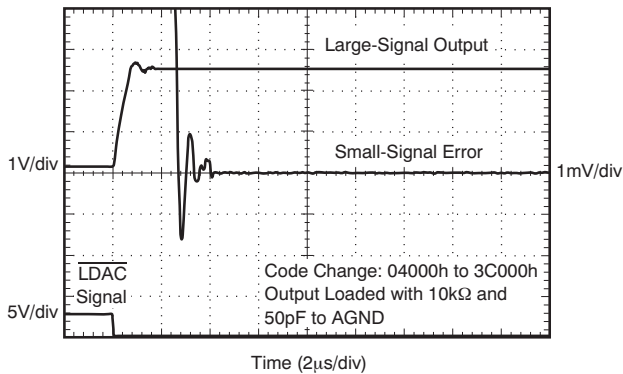

Figure 60. Large-Signal Settling Time

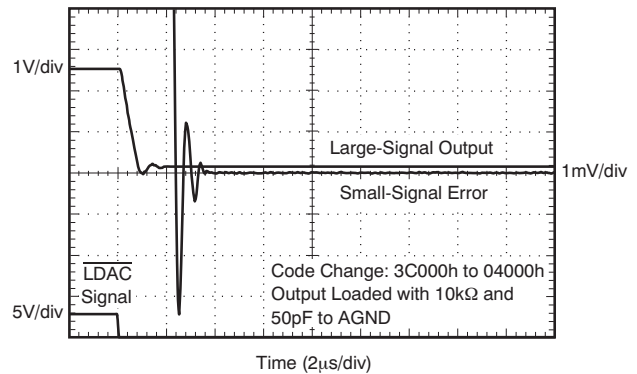
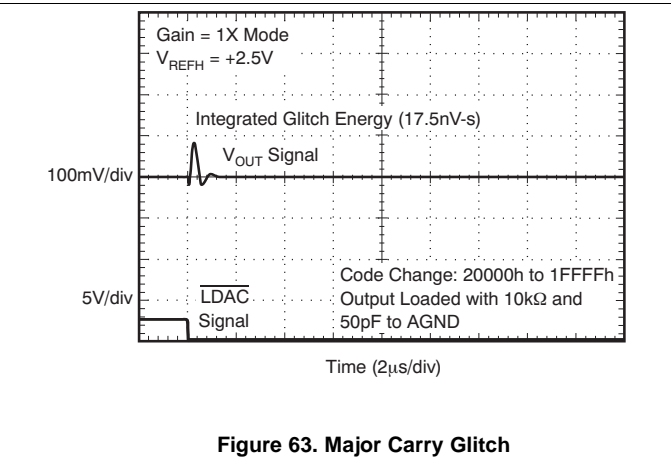
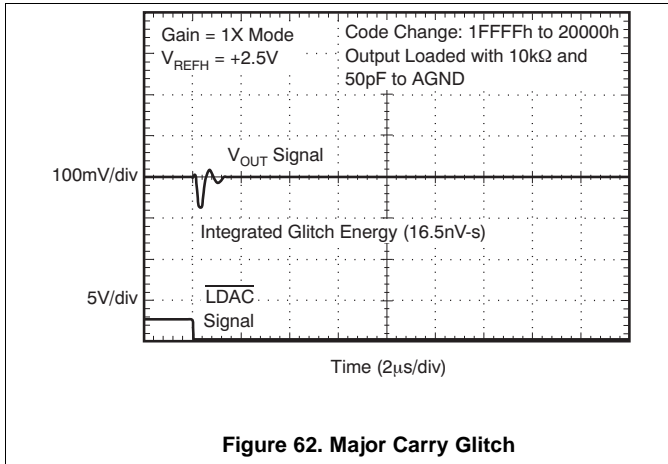

Figure 61. Large-Signal Settling Time

Typical Characteristics: AV_{DD} = 2.7 V (continued)

at T_A = 25°C, V_{REFH} = 2.5 V, V_{REFL} = 0 V, and gain = 1X mode (unless otherwise noted)



7 Detailed Description

7.1 Overview

The DAC9881 is a single-channel, 18-bit, serial-input, voltage-output digital-to-analog converter (DAC). The architecture is an R-2R ladder configuration with the four MSBs segmented, followed by an operational amplifier that serves as a buffer, as shown in Figure 64. The on-chip output buffer allows rail-to-rail output swings while providing a low output impedance to drive loads. The DAC9881 operates from a single analog power supply that ranges from 2.7 V to 5.5 V, and typically consumes 850 μ A when operating with a 5-V supply. Data are written to the device in a 24-bit word format, using an SPI serial interface. To enable compatibility with 1.8-V, 3-V, or 5-V logic families, an IOV_{DD} supply pin is provided. This pin allows the DAC9881 input and output logic to be powered from the same logic supply used to interface signals to and from the device. Internal voltage translators are included in the DAC9881 to interface digital signals to the device core. See Figure 65 for the basic configuration of the DAC9881.

To provide a known power-up state, the DAC9881 is designed with a power-on reset function. Upon power-up, the DAC9881 is reset to either zero-scale or midscale depending on the state of the RSTSEL pin. A hardware reset can be performed by using the RST and RSTSEL pins.

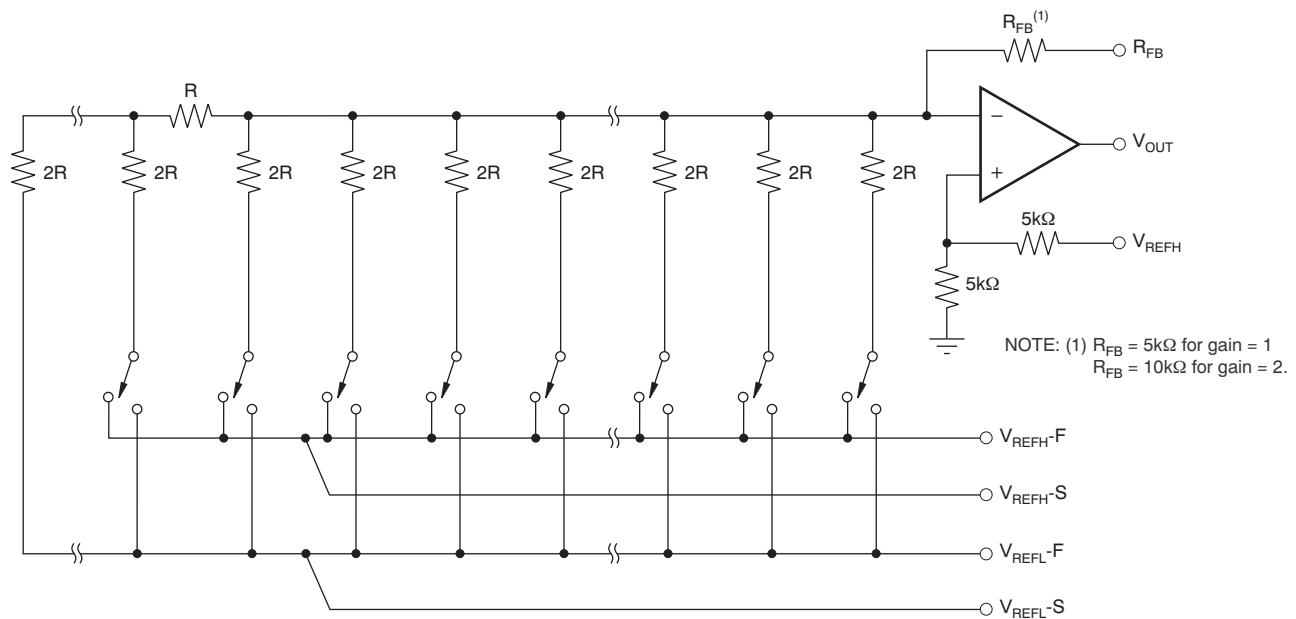
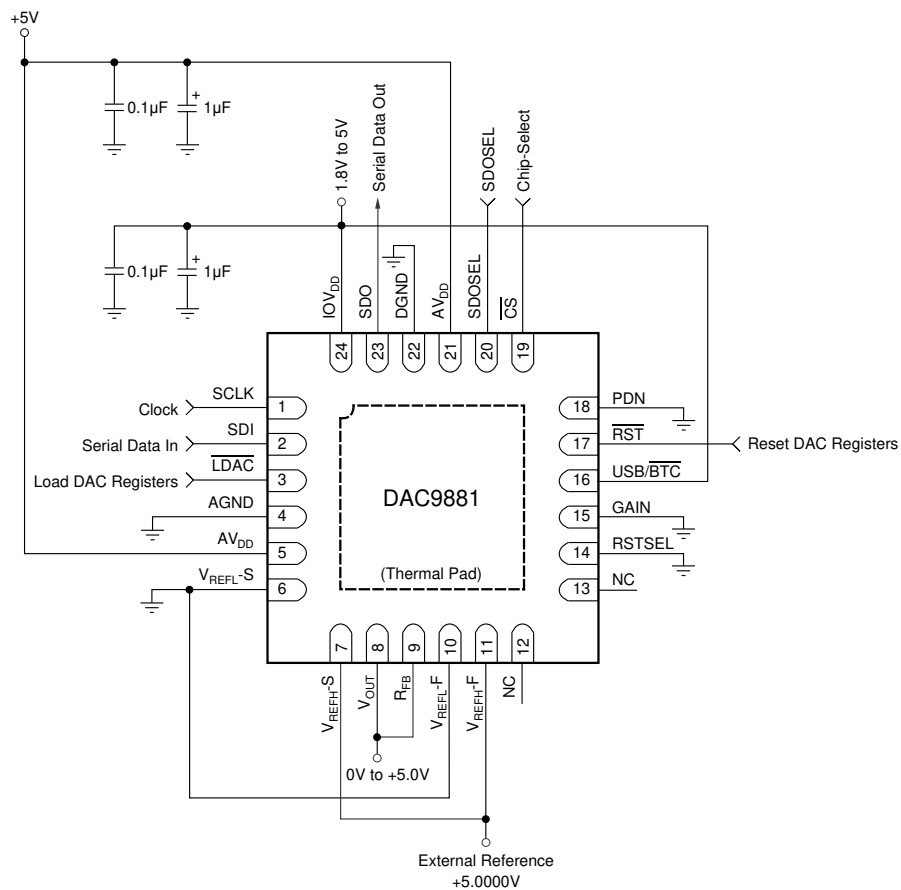

Figure 64. DAC9881 Architecture

Overview (continued)



Copyright © 2016, Texas Instruments Incorporated

Figure 65. Basic Configuration

7.2 Functional Block Diagram

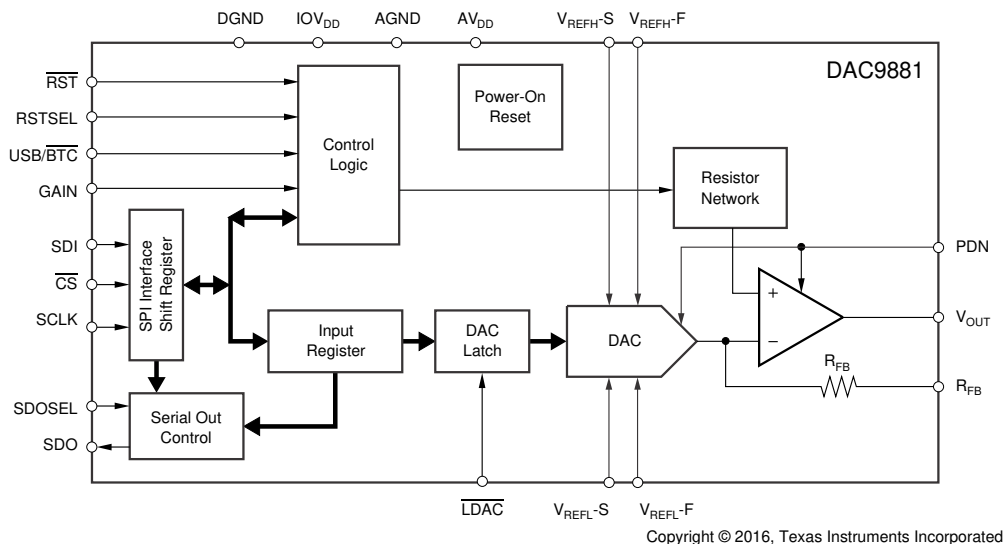

Copyright © 2016, Texas Instruments Incorporated

7.3 Feature Description

7.3.1 Analog Output

The DAC9881 offers a force and sense output configuration for the high open-loop gain output amplifier. This feature allows the loop around the output amplifier to be closed at the load (as shown in Figure 66), thus ensuring an accurate output voltage. The output buffer V_{OUT} and R_{FB} pins are provided so that the output op amp buffer feedback can be connected at the load. Without a driven load, the DAC9881 output typically swings to within 15 mV of the AGND and AV_{DD} supply rails. Because of the high accuracy of these DACs, system design problems such as grounding and wiring resistance become very important. A 18-bit converter with a 5-V full-scale range has an LSB value of 19 μ V. The DAC9881 has a typical feedback resistor current of 0.5 mA; thus, a series wiring resistance of only 100 m Ω (R_{W1}) causes a voltage drop of 50 μ V. In terms of a system layout, the resistivity of a typical 1-ounce copper-clad printed circuit board (PCB) is 0.5-m Ω per square. For a 0.5-mA current, a 0.25-mm wide printed-circuit conductor 25-mm long results in a voltage drop of 25 μ V.

NOTE

the wiring resistance of R_{W2} is not critical as long as the feedback resistor (R_{FB}) is connected at the driven load.

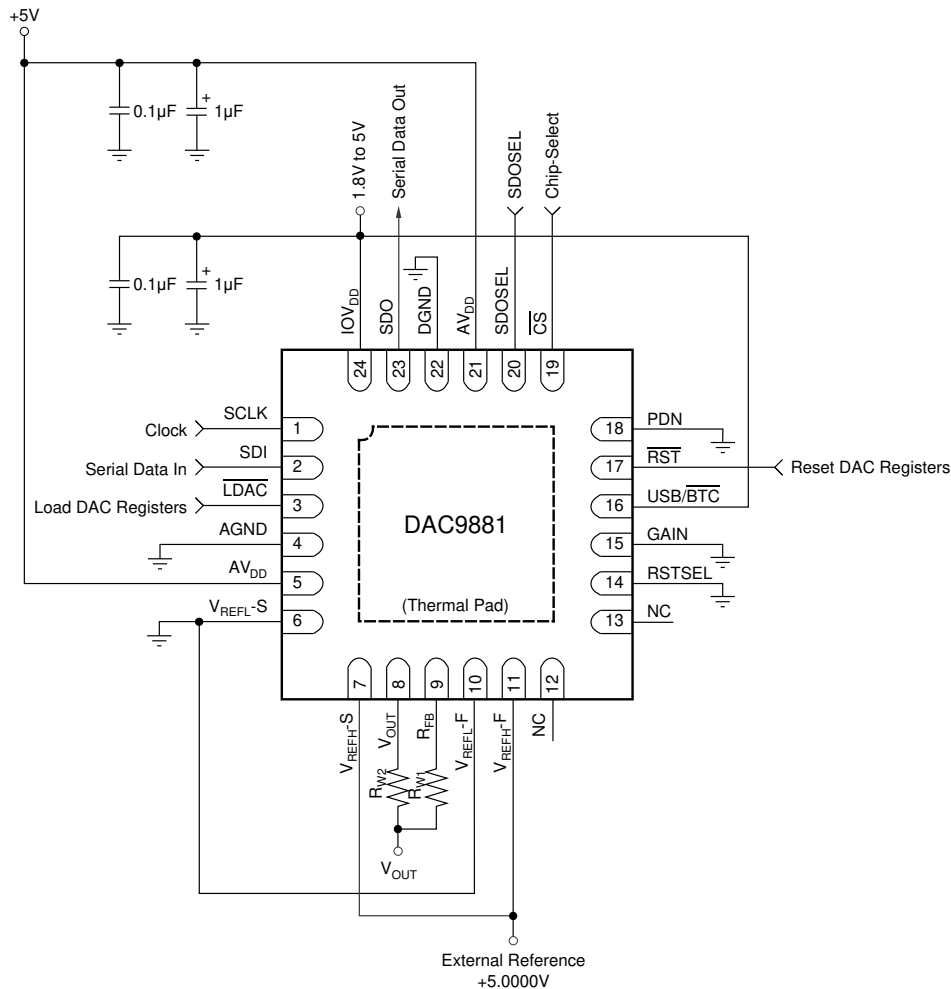

Copyright © 2016, Texas Instruments Incorporated

Figure 66. Analog Output Closed-Loop Configuration
(R_{W1} and R_{W2} Represent Wiring Resistance)

Feature Description (continued)

7.3.2 Reference Inputs

The reference high input, V_{REFH} , can be set to any voltage in the range of 1.25 V to AV_{DD} . The reference low input, V_{REFL} , can be set to any voltage in the range of -0.2 V to $+0.2$ V (to provide a small offset to the output of the DAC9881, if desired). The current into V_{REFH} and out of V_{REFL} depends on the DAC code, and can vary from approximately 0.5 mA to 1 mA in the gain = 1X mode of operation. The reference high and low inputs appear as variable loads to the external reference circuit. If the external references can source or sink the required current, and if low impedance connections are made to the V_{REFH} and V_{REFL} pins, external reference buffers are not required. Figure 65 shows a simple configuration of the DAC9881 using external references without force and sense reference buffers.

Kelvin sense connections for the reference high and low are included on the DAC9881. When properly used with external reference buffer op amps, these reference Kelvin sense pins make sure that the driven reference high and low voltages remain stable versus varying reference load currents. Figure 67 shows an example of a reference force and sense configuration of the DAC9881 operating from a single analog reference voltage. Both the V_{REFL} and V_{REFH} reference voltages are set to levels of 100 mV from the DAC9881 supply rails, and are derived from a 5-V external reference. Figure 68 illustrates the effect of not using the reference force and sense buffers to drive the DAC9881 V_{REFL} and V_{REFH} pins. Figure 69 shows the improvement when using the reference configuration.

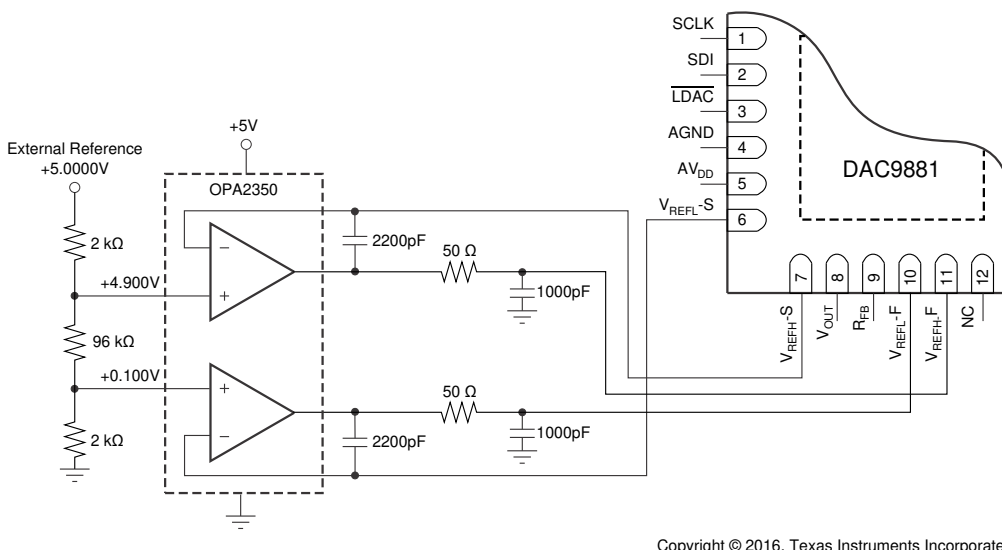

Copyright © 2016, Texas Instruments Incorporated

Figure 67. Buffered References ($V_{REFH} = +4.900$ V and $V_{REFL} = 100$ mV).

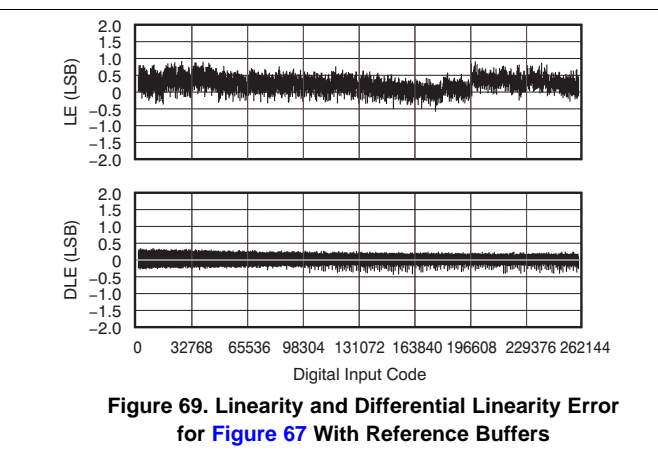
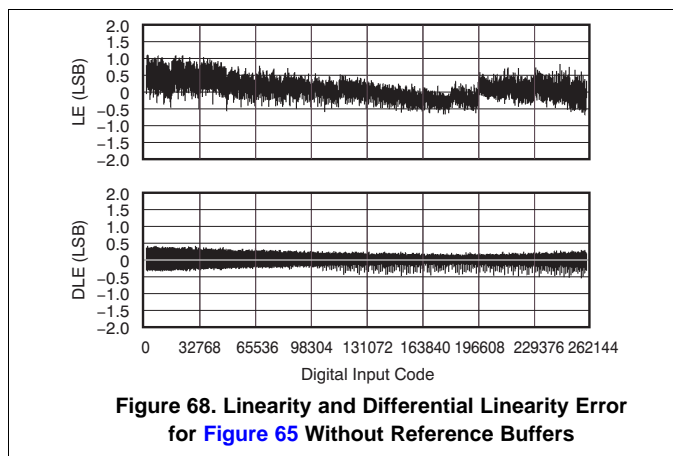

Feature Description (continued)

7.3.3 Output Range

The maximum output range of the DAC9881 is V_{REFL} to $(V_{REFH} - V_{REFL}) \times G$, where G is the output buffer gain set by the GAIN pin. When the GAIN pin is connected to DGND, the output buffer gain = 1. When the GAIN pin is connected to IOV_{DD}, the output buffer gain = 2. The output range must not be greater than AV_{DD}; otherwise, output saturation occurs. The DAC9881 output transfer function is given in [Equation 1](#):

$$V_{OUT} = \frac{V_{REFH} - V_{REFL}}{262144} \times \text{CODE} \times \text{Buffer Gain} + V_{REFL}$$

where

- CODE = 0 to 262143. This is the digital code loaded to the DAC
 - Buffer Gain = 1 or 2 (set by the GAIN pin)
 - V_{REFH} = reference high voltage applied to the device
 - V_{REFL} = reference low voltage applied to the device
- (1)

7.3.4 Input Data Format

The USB/ $\overline{\text{BTC}}$ pin defines the input data format. When this pin is connected to IOV_{DD}, the input data format is straight binary, as shown in [Table 1](#). When this pin is connected to DGND, the input data format is twos complement, as shown in [Table 2](#).

Table 1. Output vs Straight Binary Code

USB CODE	5-V RANGE	DESCRIPTION
3FFFFh	+4.99998	+Full-scale – 1 LSB
30000h	+3.75000	3/4-scale
20000h	+2.50000	Midscale
10000h	+1.25000	1/4-scale
00000h	0.00000	Zero-scale

Table 2. Output vs Twos Complement Code

$\overline{\text{BTC}}$ CODE	5-V RANGE	DESCRIPTION
1FFFFh	+4.99998	+Full-scale – 1 LSB
10000h	+3.75000	3/4-scale
00000h	+2.50000	Midscale
3FFFFh	+2.49998	Midscale – 1LSB
30000h	+1.25000	1/4-scale
20000h	0.00000	Zero-scale

7.3.5 Hardware Reset

When the $\overline{\text{RST}}$ pin is low, the device is in hardware reset, and the input register and DAC latch are set to the value defined by the RSTSEL pin. After $\overline{\text{RST}}$ goes high, the device is in normal operating mode, and the input register and DAC latch maintain the reset value until new data are written. When USB/ $\overline{\text{BTC}}$ is connected to DGND, the device is in two's complement mode. In this mode, the $\overline{\text{LDAC}}$ pin cannot be kept at logic level 0 or toggled when a hardware reset is issued before writing a valid DAC data.

7.3.6 Power-On Reset

The DAC9881 has a power-on reset feature. After power-on, the value of the input register, the DAC latch, and the output from the V_{OUT} pin are set to the value defined by the RSTSEL pin.

7.3.6.1 Program Reset Value

After a power-on reset or a hardware reset, the output voltage from the V_{OUT} pin and the values of the input register and DAC latch are determined by the status of the RSTSEL pin and the input data format, as shown in [Table 3](#).

Table 3. Reset Values

$\overline{\text{LDAC}}$ PIN	RSTSEL PIN	USB/ $\overline{\text{BTC}}$ PIN	INPUT FORMAT	V_{OUT}	VALUE OF INPUT REGISTER AND DAC LATCH
DGND or IOV _{DD}	DGND	IOV _{DD}	Straight Binary	0	00000h
DGND or IOV _{DD}	IOV _{DD}	IOV _{DD}	Straight Binary	Midscale	20000h
IOV _{DD}	DGND	DGND	Twos Complement	0	00000h
IOV _{DD}	IOV _{DD}	DGND	Twos Complement	Midscale	20000h

7.3.7 Power Down

The DAC9881 has a hardware power-down feature. When the PDN pin is high, the device is in power-down mode. When the device is in power-down, the V_{OUT} pin is connected to ground through an internal 10k Ω resistor, but the contents of the input register and the DAC latch do not change and SPI communication remains active. When the PDN pin returns low, the device returns to normal operation.

7.3.8 Double-Buffered Interface

The DAC9881 has a double-buffered interface consisting of two register banks: the input register and the DAC latch. The input register is connected directly to the input shift register and the digital code is transferred to the input register upon completion of a valid write sequence. The DAC latch contains the digital code used by the resistor R-2R ladder. The contents of the DAC latch defines the output from the DAC.

Access to the DAC latch is controlled by the $\overline{\text{LDAC}}$ pin. When $\overline{\text{LDAC}}$ is high, the DAC latch is latched and the input register can change state without affecting the contents of the DAC latch. When $\overline{\text{LDAC}}$ is low, however, the DAC latch becomes transparent and the contents of the input register is transferred to the DAC register.

7.3.8.1 Load DAC Pin ($\overline{\text{LDAC}}$)

$\overline{\text{LDAC}}$ transfers data from the input register to the DAC latch (and, therefore, updates the DAC output). The contents of the DAC latch (and the output from DAC) can be changed in two ways, depending on the status of $\overline{\text{LDAC}}$.

7.3.8.1.1 Synchronous Mode

When $\overline{\text{LDAC}}$ is tied low, the DAC latch updates as soon as new data are transferred into the input register after the rising edge of $\overline{\text{CS}}$.

7.3.8.1.2 Asynchronous Mode

When $\overline{\text{LDAC}}$ is high, the DAC latch is latched. The DAC latch (and DAC output) is not updated at the same time that the input register is written to. When $\overline{\text{LDAC}}$ goes low, the DAC latch updates with the contents of the input register.

7.3.9 1.8-V to 5-V Logic Interface

All digital input and output pins are compatible with any logic supply voltage between 1.8 V and 5 V. Connect the interface logic supply voltage to the IOV_{DD} pin. Although timing is specified down to 2.7 V (see the *timing diagrams*), IOV_{DD} can operate as low as 1.8 V, but with degraded timing and temperature performance. For the lowest power consumption, logic V_{IH} levels should be as close as possible to IOV_{DD}, and logic V_{IL} levels should be as close as possible to GND.

7.3.10 Power-Supply Sequence

For the device to work properly, IOV_{DD} must not come up before AV_{DD}, and the reference voltage must come up after the AV_{DD} supply. Additionally, because the DAC input shift register is not reset during a power-on reset or hardware reset, the $\overline{\text{CS}}$ pin must not be unintentionally asserted during power-up of the device. To avoid improper power-up, it is recommended that the $\overline{\text{CS}}$ and $\overline{\text{LDAC}}$ pins be connected to IOV_{DD} through pullup resistors. To make sure that the electrostatic discharge (ESD) protection circuitry of this device is not activated, all other digital pins must be held at ground potential until IOV_{DD} is applied.

7.4 Device Functional Modes

7.4.1 Serial Interface

The DAC9881 is controlled by a versatile three-wire serial interface that operates at clock rates of up to 50 MHz and is compatible with SPI, QSPI™, MICROWIRE, and DSP interface standards.

7.4.1.1 Input Shift Register

Data are loaded into the device as a 24-bit word under the control of the serial clock input, SCLK. The timing diagrams for this operation are shown in *timing diagrams* section.

The \overline{CS} input is a level-triggered input that acts as a frame synchronization signal and chip enable. Data can be transferred into the device only while \overline{CS} is low. When \overline{CS} is high, the SCLK and SDI signals are blocked out, and SDO is in high-Z status. To start the serial data transfer, \overline{CS} should be taken low, observing the minimum delay from \overline{CS} falling edge to SCLK rising edge, t_2 . After \overline{CS} goes low, serial input data from SDI are clocked into the device input shift register on the rising edges of SCLK for 24 or more clock pulses. If a frame contains less than 24 bits of data, the frame is invalid. Invalid input data are not written into the input register and DAC, although the input register and DAC will continue to hold data from the preceding valid data cycle. If more than 24 bits of data are transmitted in one frame, the last 24 bits are written into the shift register and DAC. \overline{CS} may be taken high after the rising edge of the 24th SCLK pulse, observing the minimum SCLK rising edge to \overline{CS} rising edge time, t_7 . The contents of the shift register are transferred into the input register on the rising edge of \overline{CS} . When data have been transferred into the input register of the DAC, the corresponding DAC register and DAC output can be updated by taking the LDAC pin low. Table 4 shows the input shift register data word format. D17 is the MSB of the 18-bit DAC data.

Table 4. Input Shift Register Data Word Format

BIT	B23	B22	B21	B20	B19	B18	B17 (MSB)	B16	B15	B14	B13	B12	B11	B10	B9	B8	B7	B6	B5	B4	B3	B2	B1	B0 (LSB)
DATA	X ⁽¹⁾	X	X	X	X	X	D17	D16	D15	D14	D13	D12	D11	D10	D9	D8	D7	D6	D5	D4	D3	D2	D1	D0

(1) X = don't care.

7.4.1.1.1 Stand-Alone Mode

When the SDOSEL pin is tied to IOV_{DD}, the interface is in Stand-Alone mode. This mode provides serial readback for diagnostic purposes. The new input data (24 bits) are clocked into the device shift register and the existing data in the input register (24 bits) are shifted out from the SDO pin. If more than 24 SCLKs are clocked when \overline{CS} is low, the contents of the input register are shifted out from the SDO pin, followed by zeroes; the last 24 bits of input data remain in the shift register. If less than 24 SCLKs are clocked while \overline{CS} is low, the data from the SDO pin are part of the data in the input register and must be ignored. Refer to Figure 2 for further details.

7.4.1.1.2 Daisy-Chain Mode

When the SDOSEL pin is tied to GND, the interface is in Daisy-Chain mode. For systems that contain several DACs, the SDO pin may be used to daisy-chain several devices together.

In Daisy-Chain mode, SCLK is continuously applied to the input shift register while \overline{CS} is low. If more than 24 clock pulses are applied, the data ripple out of the shift register and appear on the SDO line. These data are clocked out on the falling edge of SCLK and are valid on the rising edge. By connecting this line to the SDI input on the next DAC in the chain, a multi-DAC interface is constructed. 24 clock pulses are required for each DAC in the chain. Therefore, the total number of clock cycles must be equal to $(24 \times N)$, where N is the total number of devices in the chain. When the serial transfer to all devices is complete, \overline{CS} should be taken high. This action prevents any further data from being clocked into the input shift register. The contents in the shift registers are transferred into the relevant input registers on the rising edge of the \overline{CS} signal.

A continuous SCLK source may be used if \overline{CS} can be held low for the correct number of clock cycles. Alternatively, a burst clock containing the exact number of clock cycles can be used and \overline{CS} can be taken high some time later. When the transfer to all input registers is complete, a common LDAC signal updates all DAC registers, and all analog outputs update simultaneously.

8 Application and Implementation

NOTE

Information in the following applications sections is not part of the TI component specification, and TI does not warrant its accuracy or completeness. TI's customers are responsible for determining suitability of components for their purposes. Customers should validate and test their design implementation to confirm system functionality.

8.1 Application Information

The excellent linearity as well as low-noise and fast settling time makes the DAC9881 a strong performer in applications such as automatic test equipment, precision instrumentation and data acquisition systems. Additionally, the energy saving feature of the device, through the PDN pin, significantly reduces power dissipation -- this mode reduces current consumption, as low as 25 μ A with a 5-V supply.

8.1.1 Bipolar Operation Using the DAC9881

The DAC9881 is designed for single-supply operation; however, a bipolar output is also possible using the circuit shown in Figure 70. This circuit gives a bipolar output voltage of V_{OUT} . When GAIN = 1, V_{OUT} can be calculated using Equation 2:

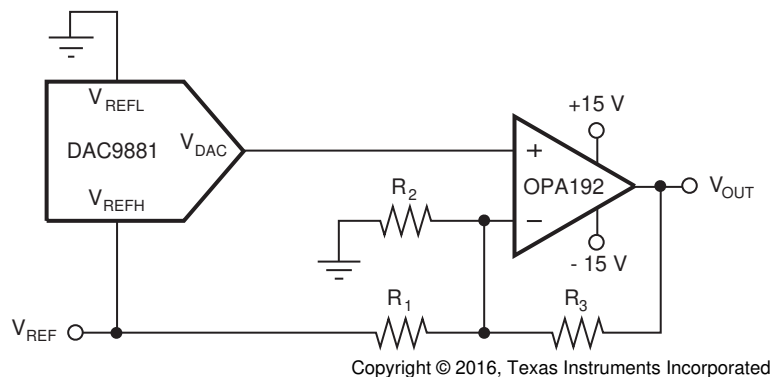

Some pins are omitted for clarity.

Figure 70. Bipolar Output Range

$$V_{OUT}(CODE) = \left[\left(V_{REF} \times \frac{CODE}{2^{18}} \right) \left(1 + \frac{R_3}{R_2} + \frac{R_3}{R_1} \right) - \left(V_{REF} \times \frac{R_3}{R_1} \right) \right]$$

where

- $V_{OUT}(CODE)$ = output voltage vs code
 - CODE = 0 to 262143. This is the digital code loaded to the DAC
 - V_{REF} = reference voltage applied to the DAC9881
- (2)

As an example, a ± 8 -V output span can be achieved by using values of 5 V, 6.25 k Ω , 16.67 k Ω , and 10 k Ω for V_{ref} , R_1 , R_2 , and R_3 respectively.

8.2 Typical Application

8.2.1 DAC9881 Sample-and-Hold Circuit

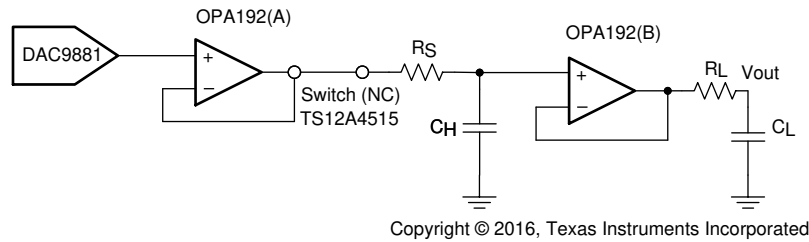

Copyright © 2016, Texas Instruments Incorporated

Figure 71. DAC9881 Sample-and-Hold Circuit

8.2.1.1 Design Requirements

The inherent architecture of the DAC9881, which consists of an R-2R architecture, enables great performance in regards to noise and accuracy, but at a cost of large glitch area. Glitch area, also known as glitch impulse area, is defined as the area associated with the overshoot or undershoot created by a code transition, and is generally quantified in Volt-seconds. Different code-to-code transitions produce different levels of glitch impulses. DACs with R-2R architectures produce large glitches during major-carry transitions.

There are two methods that can be used to reduce this glitch area:

1. Add an external RC Filter to the output of the DAC.
 - The low-pass filter helps attenuate high-frequency glitches that would normally propagate to the DAC output. Best practice is to use a small resistor value, as large resistance develops a large potential drop and reduces the voltage seen at the load. Capacitor values can be determined from the desired cutoff frequency of the low-pass filter, as well as settling time.
2. Another technique is to employ a Sample and Hold (S&H) circuit following the DAC output.
 - In its simplest form, the sample and hold circuit can be constructed from the following components: a capacitive element, output buffer, and switch. A schematic of the simplified S&H is shown in Figure 72.

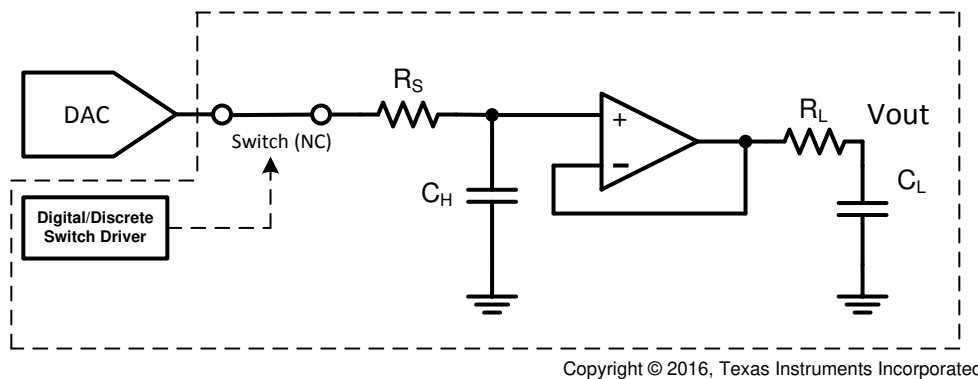

Copyright © 2016, Texas Instruments Incorporated

Figure 72. Simplified Sample and Hold Circuit

8.2.1.2 Detailed Design Procedure

The Sample/Track and Hold modes of operation correspond to the state of the switch, which connects the DAC output to the hold capacitor C_H . In sample mode – also referred to as track mode -- the switch is closed, allowing the capacitor to charge or discharge to the sampled DAC output voltage. The operational amplifier is configured as a buffer, which tracks and relays the voltage seen across C_H to the output of the circuit. In hold mode, the switch opens, disconnecting C_H from the DAC output. The DAC is updated while the circuit is in hold mode, preventing any DAC major carry glitches from propagating to the S&H output. The capacitor retains the previous sampled voltage, and this value is buffered to the output of the circuit. In real circuits, switch leakage and operational amplifier input bias current must be considered as it will impact circuit performance. The switch is generally controlled by an external discrete or digital driver.

Typical Application (continued)

After the DAC glitch relays, the switch closes and re-enters sample or track mode.

More information related to this circuit can be found in [Sample and Hold Glitch Reduction for Precision Outputs Design Guide](#) (TIDU022).

8.2.1.3 Application Curves

Glitch reduction and total unadjusted error (TUE) plots of the solution presented in [Sample and Hold Glitch Reduction for Precision Outputs Design Guide](#) (TIDU022) is shown in the following plots. The glitch area is reduced from 35.11 nVs to 2.01 nVs.

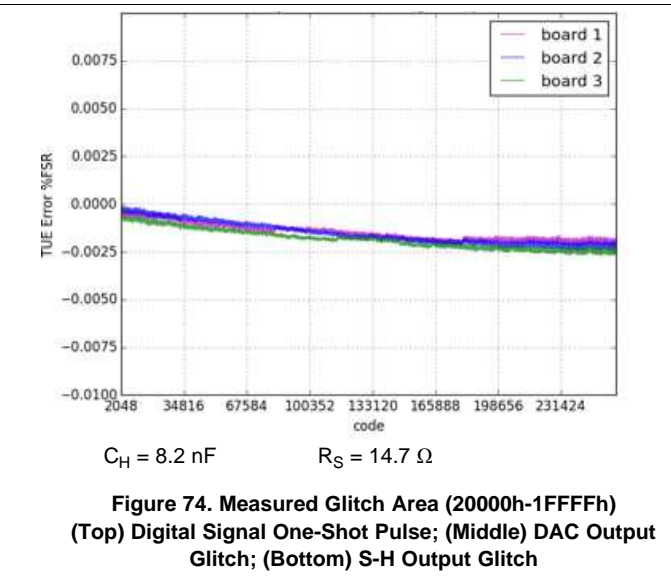
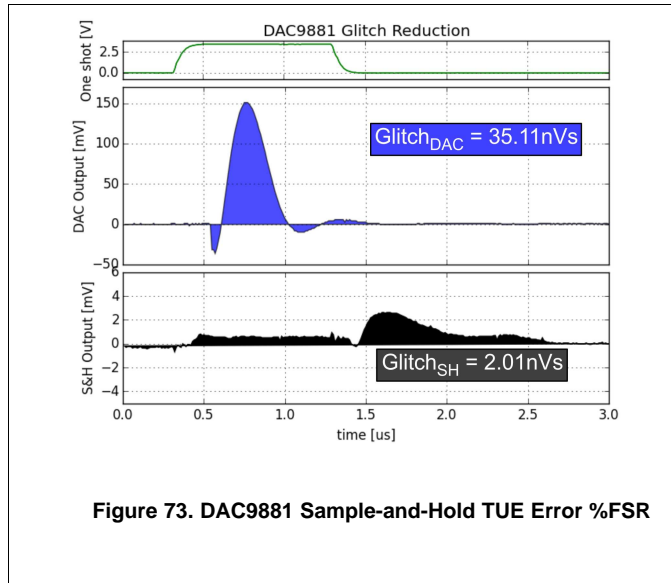

8.3 System Example

Figure 75 displays a typical serial interface that may be used when connecting the DAC9881's SPI serial interface to a (master) microcontroller. The setup for the interface is as follows: The microcontroller's output SPI CLK drives the SCLK pin of the DAC9881, while the DAC9881 SDI pin is driven by the MOSI pin of the microcontroller. The CS pin of the DAC9881 can be asserted from a general program input/output pin of the microcontroller. When data are to be transmitted to the DAC9881, the CS pin is taken low. The data from the microcontroller is then transmitted to the DAC9881, totaling 24 bits latched into the DAC9881 device through the negative edge of SCLK. CS is then brought high after the completed write. The DAC9881 requires its data with the MSB as the first bit received.

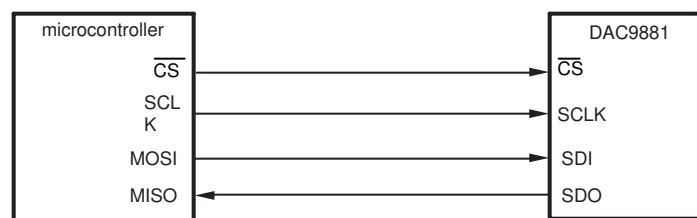

Copyright © 2016, Texas Instruments Incorporated

Figure 75. Simplified Sample-and-Hold Circuit

9 Power Supply Recommendations

The DAC9881 operates within the specified supply voltage range of 2.7 V to 5.5 V. The power applied to AVDD should be well regulated and low noise. Switching power supplies and DC/DC converters often have high-frequency glitches or spikes riding on the output voltage. In addition, digital components can create similar high frequency spikes. This noise can easily couple into the DAC output voltage through various paths between the power connections and analog output. To further minimize noise from the power supply, a strong recommendation is to include a 1- μ F to 10- μ F capacitor and 0.1- μ F bypass capacitor. The current consumption on the AVDD pin, the short-circuit current limit, and the load current for the device is listed in [Electrical Characteristics](#). The power supply must meet the aforementioned current requirements.

10 Layout

10.1 Layout Guidelines

A precision analog component requires careful layout, the list below provides some insight into good layout practices.

- All Power Supply pins should be bypassed to ground with a low ESR ceramic bypass capacitor. The typical recommended bypass capacitance is 0.1 μ F to 0.22 μ F ceramic with a X7R or NP0 dielectric.
- Power supplies and VrefH/L bypass capacitors should be placed close to terminals to minimize inductance and optimize performance.
- A high-quality ceramic type NP0 or X7R is recommended for optimal performance across temperature, and a very low dissipation factor.
- The digital and analog sections should have proper placement with respect to the digital pins and analog pins of the DAC9881 device. The separation of analog and digital blocks allows for better design and practice because of less coupling into neighboring blocks, and less interaction between analog and digital return currents.

10.2 Layout Example

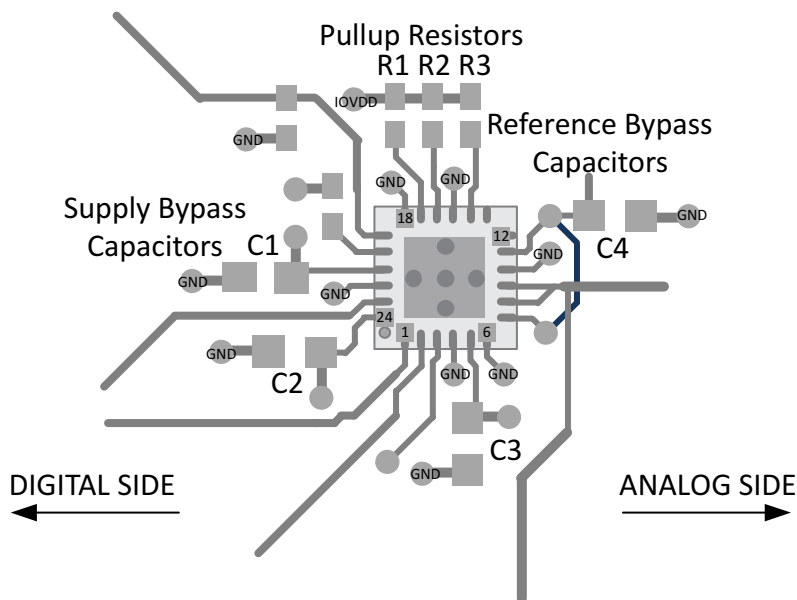

Figure 76. DAC9881 Basic Layout Example

11 器件和文档支持

11.1 文档支持

11.1.1 相关文档

请参阅如下相关文档：

- 《DAC9881 评估模块用户指南》
- 《通过采样和减少干扰实现高精度输出》设计指南

11.2 接收文档更新通知

要接收文档更新通知，请导航至 ti.com 上的器件产品文件夹。单击右上角的通知我进行注册，即可每周接收产品信息更改摘要。有关更改的详细信息，请查看任何已修订文档中包含的修订历史记录。

11.3 支持资源

TI E2E™ [support forums](#) are an engineer's go-to source for fast, verified answers and design help — straight from the experts. Search existing answers or ask your own question to get the quick design help you need.

Linked content is provided "AS IS" by the respective contributors. They do not constitute TI specifications and do not necessarily reflect TI's views; see TI's [Terms of Use](#).

11.4 商标

E2E is a trademark of Texas Instruments.

QSPI is a trademark of Motorola, Inc.

All other trademarks are the property of their respective owners.

11.5 静电放电警告



这些装置包含有限的内置 ESD 保护。存储或装卸时，应将导线一起截短或将装置放置于导电泡棉中，以防止 MOS 门极遭受静电损伤。

11.6 Glossary





[SLYZ022](#) — *TI Glossary*.

This glossary lists and explains terms, acronyms, and definitions.

12 机械、封装和可订购信息

以下页面包含机械、封装和可订购信息。这些信息是指定器件的最新可用数据。数据如有变更，恕不另行通知，且不会对此文档进行修订。如需获取此数据表的浏览器版本，请查阅左侧的导航栏。

PACKAGING INFORMATION

Orderable Device	Status (1)	Package Type	Package Drawing	Pins	Package Qty	Eco Plan (2)	Lead finish/ Ball material (6)	MSL Peak Temp (3)	Op Temp (°C)	Device Marking (4/5)	Samples
DAC9881SBRGER	ACTIVE	VQFN	RGE	24	3000	RoHS & Green	Call TI	Level-2-260C-1 YEAR	-40 to 105	DAC 9881 B	
DAC9881SBRGET	ACTIVE	VQFN	RGE	24	250	RoHS & Green	Call TI	Level-2-260C-1 YEAR	-40 to 105	DAC 9881 B	
DAC9881SRGER	ACTIVE	VQFN	RGE	24	3000	RoHS & Green	Call TI	Level-2-260C-1 YEAR	-40 to 105	DAC 9881	
DAC9881SRGET	ACTIVE	VQFN	RGE	24	250	RoHS & Green	Call TI	Level-2-260C-1 YEAR	-40 to 105	DAC 9881	
DAC9881SRGETG4	ACTIVE	VQFN	RGE	24	250	RoHS & Green	Call TI	Level-2-260C-1 YEAR	-40 to 105	DAC 9881	

(1) The marketing status values are defined as follows:

ACTIVE: Product device recommended for new designs.

LIFEBUY: TI has announced that the device will be discontinued, and a lifetime-buy period is in effect.

NRND: Not recommended for new designs. Device is in production to support existing customers, but TI does not recommend using this part in a new design.

PREVIEW: Device has been announced but is not in production. Samples may or may not be available.

OBSELETE: TI has discontinued the production of the device.

(2) **RoHS:** TI defines "RoHS" to mean semiconductor products that are compliant with the current EU RoHS requirements for all 10 RoHS substances, including the requirement that RoHS substance do not exceed 0.1% by weight in homogeneous materials. Where designed to be soldered at high temperatures, "RoHS" products are suitable for use in specified lead-free processes. TI may reference these types of products as "Pb-Free".

RoHS Exempt: TI defines "RoHS Exempt" to mean products that contain lead but are compliant with EU RoHS pursuant to a specific EU RoHS exemption.

Green: TI defines "Green" to mean the content of Chlorine (Cl) and Bromine (Br) based flame retardants meet JS709B low halogen requirements of <=1000ppm threshold. Antimony trioxide based flame retardants must also meet the <=1000ppm threshold requirement.

(3) MSL, Peak Temp. - The Moisture Sensitivity Level rating according to the JEDEC industry standard classifications, and peak solder temperature.

(4) There may be additional marking, which relates to the logo, the lot trace code information, or the environmental category on the device.

(5) Multiple Device Markings will be inside parentheses. Only one Device Marking contained in parentheses and separated by a "-" will appear on a device. If a line is indented then it is a continuation of the previous line and the two combined represent the entire Device Marking for that device.

⁽⁶⁾ Lead finish/Ball material - Orderable Devices may have multiple material finish options. Finish options are separated by a vertical ruled line. Lead finish/Ball material values may wrap to two lines if the finish value exceeds the maximum column width.

Important Information and Disclaimer:The information provided on this page represents TI's knowledge and belief as of the date that it is provided. TI bases its knowledge and belief on information provided by third parties, and makes no representation or warranty as to the accuracy of such information. Efforts are underway to better integrate information from third parties. TI has taken and continues to take reasonable steps to provide representative and accurate information but may not have conducted destructive testing or chemical analysis on incoming materials and chemicals. TI and TI suppliers consider certain information to be proprietary, and thus CAS numbers and other limited information may not be available for release.

In no event shall TI's liability arising out of such information exceed the total purchase price of the TI part(s) at issue in this document sold by TI to Customer on an annual basis.

TAPE AND REEL INFORMATION

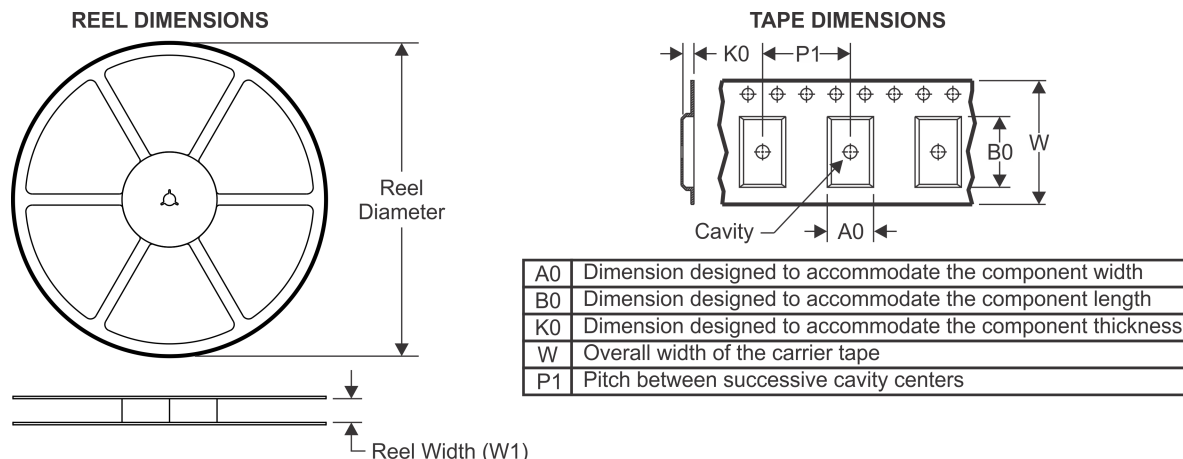

QUADRANT ASSIGNMENTS FOR PIN 1 ORIENTATION IN TAPE

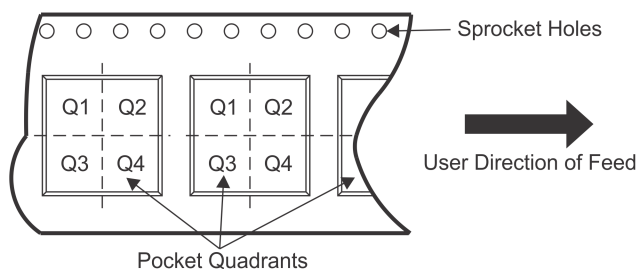

*All dimensions are nominal

Device	Package Type	Package Drawing	Pins	SPQ	Reel Diameter (mm)	Reel Width W1 (mm)	A0 (mm)	B0 (mm)	K0 (mm)	P1 (mm)	W (mm)	Pin1 Quadrant
DAC9881SBRGER	VQFN	RGE	24	3000	330.0	12.4	4.3	4.3	1.5	8.0	12.0	Q2
DAC9881SRGER	VQFN	RGE	24	3000	330.0	12.4	4.3	4.3	1.5	8.0	12.0	Q2

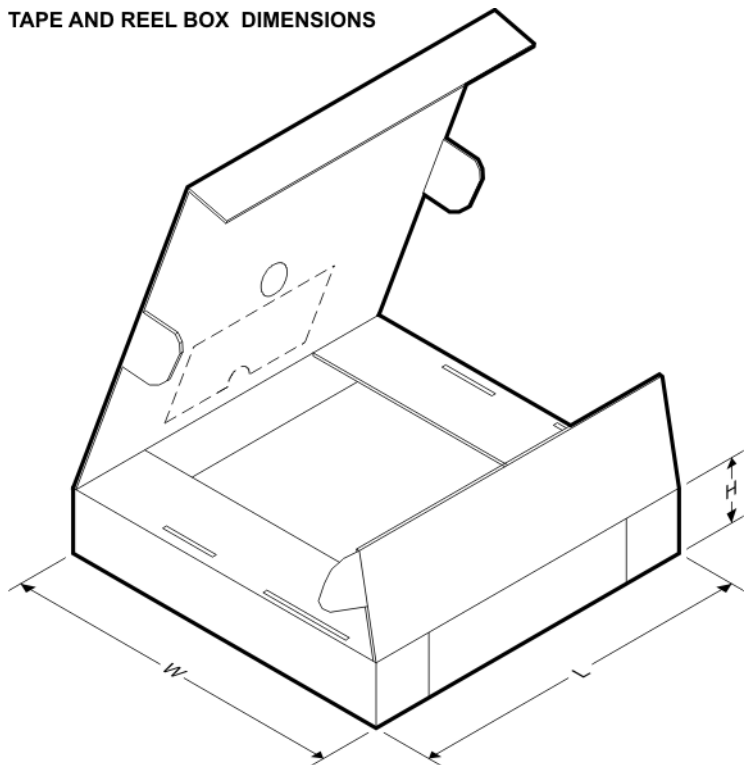
TAPE AND REEL BOX DIMENSIONS

*All dimensions are nominal

Device	Package Type	Package Drawing	Pins	SPQ	Length (mm)	Width (mm)	Height (mm)
DAC9881SBRGER	VQFN	RGE	24	3000	350.0	350.0	43.0
DAC9881SRGER	VQFN	RGE	24	3000	350.0	350.0	43.0

RGE 24

GENERIC PACKAGE VIEW

VQFN - 1 mm max height

PLASTIC QUAD FLATPACK - NO LEAD

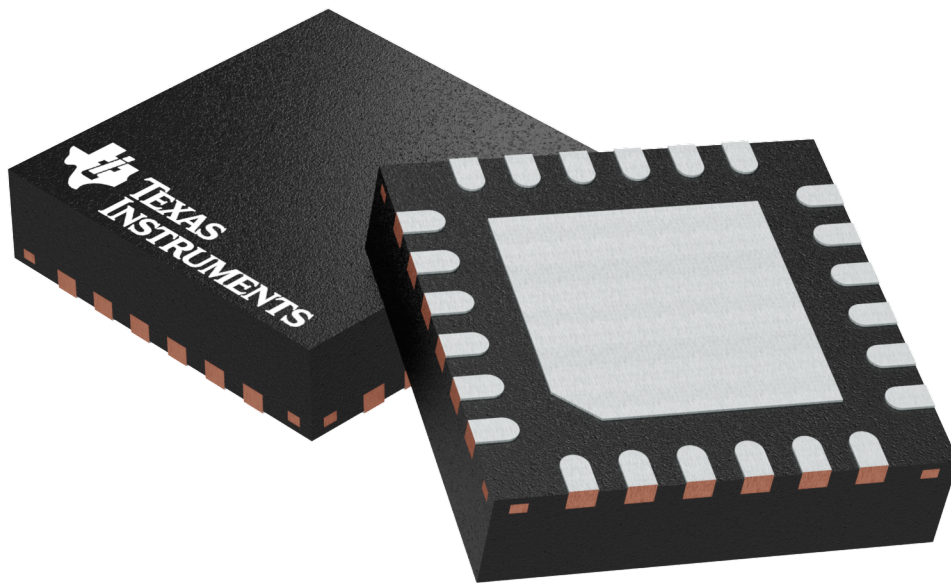

Images above are just a representation of the package family, actual package may vary.
Refer to the product data sheet for package details.

4204104/H

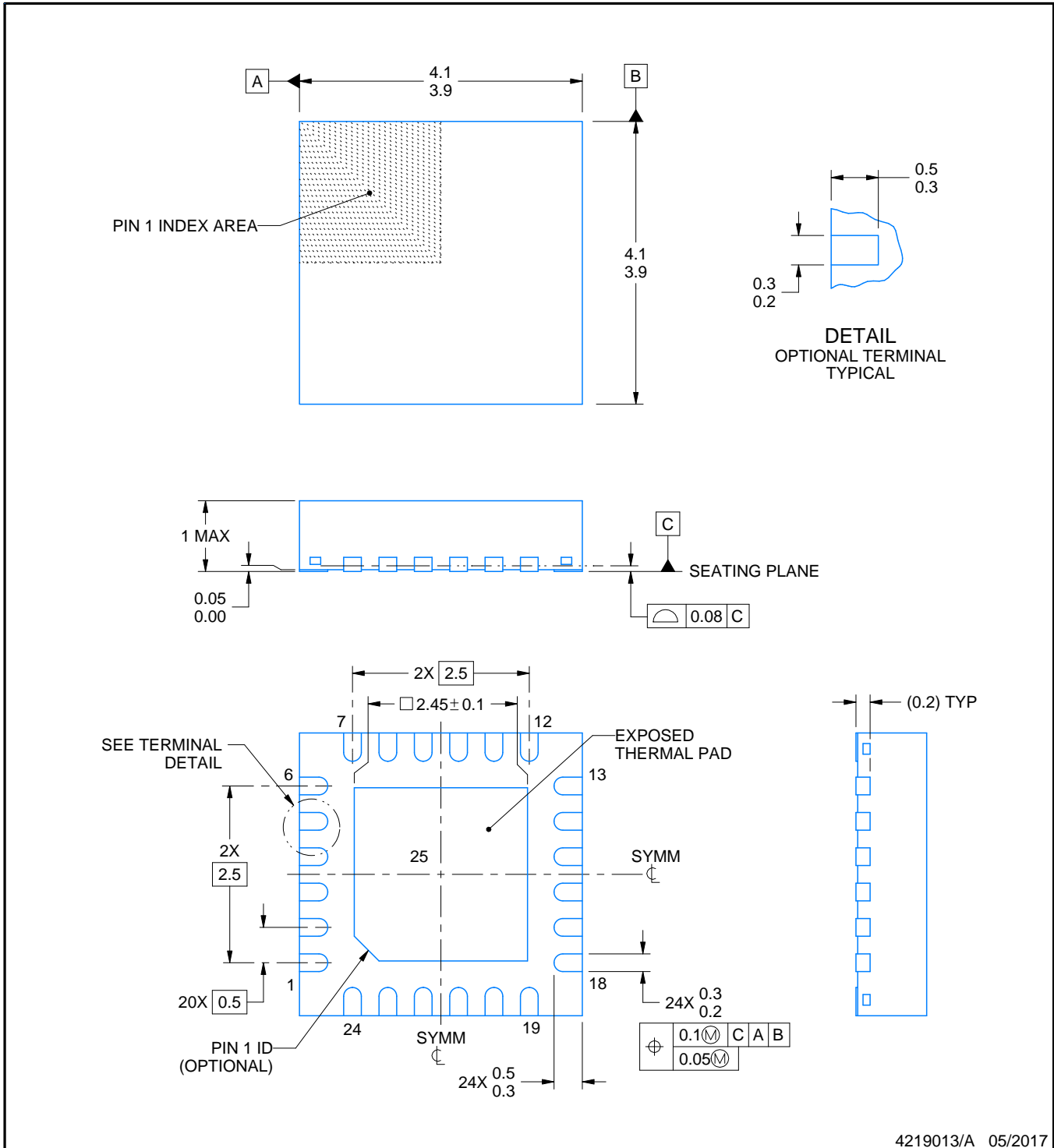
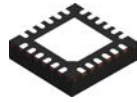

4219013/A 05/2017

NOTES:

1. All linear dimensions are in millimeters. Any dimensions in parenthesis are for reference only. Dimensioning and tolerancing per ASME Y14.5M.
2. This drawing is subject to change without notice.
3. The package thermal pad must be soldered to the printed circuit board for thermal and mechanical performance.

EXAMPLE BOARD LAYOUT

RGE0024B

VQFN - 1 mm max height

PLASTIC QUAD FLATPACK - NO LEAD

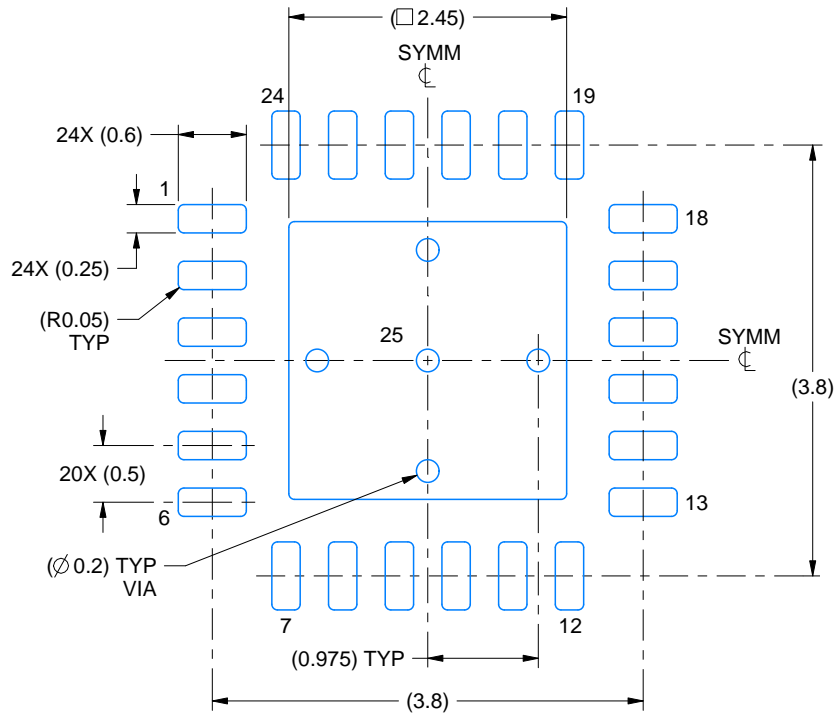

LAND PATTERN EXAMPLE
EXPOSED METAL SHOWN
SCALE:15X

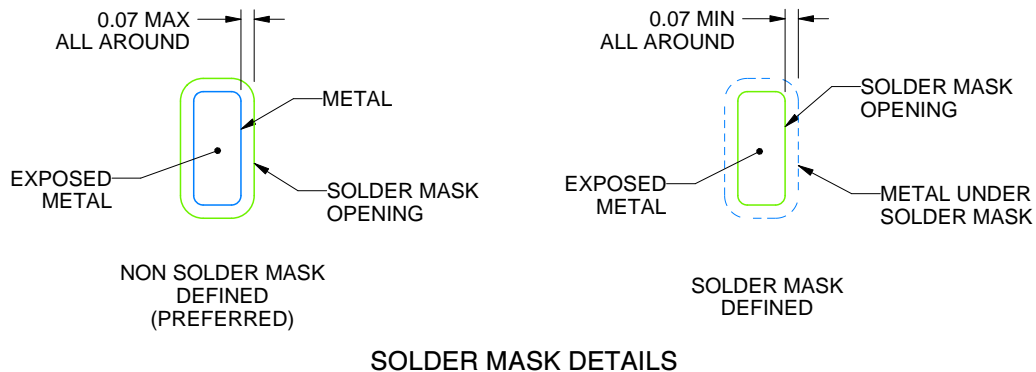

SOLDER MASK DETAILS

4219013/A 05/2017

NOTES: (continued)

- This package is designed to be soldered to a thermal pad on the board. For more information, see Texas Instruments literature number SLUA271 (www.ti.com/lit/slua271).
- Vias are optional depending on application, refer to device data sheet. If any vias are implemented, refer to their locations shown on this view. It is recommended that vias under paste be filled, plugged or tented.

EXAMPLE STENCIL DESIGN

RGE0024B

VQFN - 1 mm max height

PLASTIC QUAD FLATPACK - NO LEAD

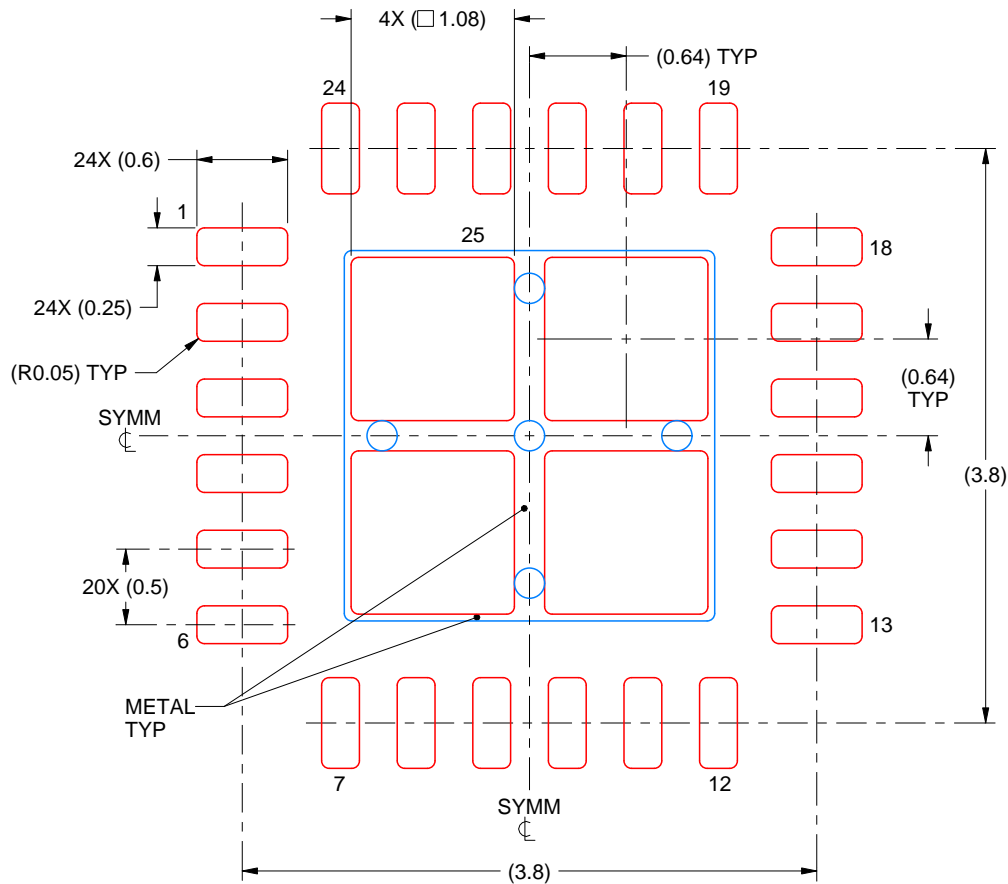

SOLDER PASTE EXAMPLE
 BASED ON 0.125 mm THICK STENCIL

EXPOSED PAD 25
 78% PRINTED SOLDER COVERAGE BY AREA UNDER PACKAGE
 SCALE:20X

4219013/A 05/2017

NOTES: (continued)

- 6. Laser cutting apertures with trapezoidal walls and rounded corners may offer better paste release. IPC-7525 may have alternate design recommendations.

重要声明和免责声明

TI“按原样”提供技术和可靠性数据（包括数据表）、设计资源（包括参考设计）、应用或其他设计建议、网络工具、安全信息和其他资源，不保证没有瑕疵且不做任何明示或暗示的担保，包括但不限于对适销性、某特定用途方面的适用性或不侵犯任何第三方知识产权的暗示担保。

这些资源可供使用 TI 产品进行设计的熟练开发人员使用。您将自行承担以下全部责任：(1) 针对您的应用选择合适的 TI 产品，(2) 设计、验证并测试您的应用，(3) 确保您的应用满足相应标准以及任何其他功能安全、信息安全、监管或其他要求。

这些资源如有变更，恕不另行通知。TI 授权您仅可将这些资源用于研发本资源所述的 TI 产品的应用。严禁对这些资源进行其他复制或展示。您无权使用任何其他 TI 知识产权或任何第三方知识产权。您应全额赔偿因在这些资源的使用中对 TI 及其代表造成的任何索赔、损害、成本、损失和债务，TI 对此概不负责。

TI 提供的产品受 [TI 的销售条款](#) 或 [ti.com](#) 上其他适用条款/TI 产品随附的其他适用条款的约束。TI 提供这些资源并不会扩展或以其他方式更改 TI 针对 TI 产品发布的适用的担保或担保免责声明。

TI 反对并拒绝您可能提出的任何其他或不同的条款。

邮寄地址：Texas Instruments, Post Office Box 655303, Dallas, Texas 75265
Copyright © 2021，德州仪器 (TI) 公司