

INA1x9-Q1 Automotive-Grade, High-Side, Current-Output, Current-Shunt Monitor

1 Features

- Qualified for Automotive Applications
- AEC-Q100 Qualified With the Following Results:
 - Device Temperature Grade 1: -40°C to 125°C Ambient Operating Temperature Range
 - Device HBM ESD Classification Level 2
 - Device CDM ESD Classification Level C6
- Complete Unidirectional High-Side Current Measurement Circuit
- Wide Supply and Common-Mode Ranges
 - INA139-Q1: 2.7 V to 40 V
 - INA169-Q1: 2.7 V to 60 V
- Independent Supply and Input Common-Mode Voltages
- Single Resistor Gain Set
- Low Quiescent Current (60 μA Typical)
- Wide Temperature Range: -40°C to $+125^{\circ}\text{C}$
- Package: TSSOP-8

2 Applications

- Electric Power Steering (EPS) Systems
- Body Control Modules
- Brake Systems
- Electronic Stability Control (ESC) Systems

3 Description

The INA139-Q1 and INA169-Q1 (INA1x9-Q1) are high-side, unidirectional, current shunt monitors. Wide input common-mode voltage range, high-speed, low quiescent current, and TSSOP-8 packaging enable use in a variety of applications.

The device converts a differential input voltage to a current output. This current is converted back to a voltage with an external load resistor that sets any gain from 1 to over 100. Although designed for current shunt measurement, the circuit invites creative applications in measurement and level shifting.

Both the INA139-Q1 and INA169-Q1 are available in a TSSOP-8 package, and are specified for the -40°C to $+125^{\circ}\text{C}$ temperature range.

Device Information⁽¹⁾

PART NUMBER	PACKAGE	BODY SIZE (NOM)
INA139-Q1	TSSOP (8)	4.40 mm x 3.00 mm
INA169-Q1		

(1) For all available packages, see the package option addendum at the end of the data sheet.

Typical Application Circuit

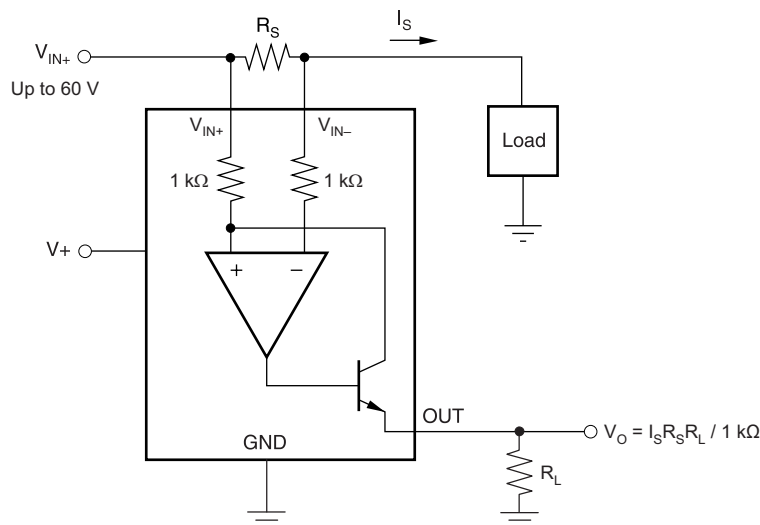

Table of Contents

1 Features	1	7.4 Device Functional Modes	9
2 Applications	1	8 Application and Implementation	9
3 Description	1	8.1 Application Information	9
4 Revision History	2	8.2 Typical Applications	11
5 Pin Configuration and Functions	3	9 Power Supply Recommendations	18
6 Specifications	3	10 Layout	18
6.1 Absolute Maximum Ratings	3	10.1 Layout Guidelines	18
6.2 ESD Ratings	3	10.2 Layout Example	18
6.3 Recommended Operating Conditions	4	11 Device and Documentation Support	19
6.4 Thermal Information	4	11.1 Related Documentation	19
6.5 Electrical Characteristics	5	11.2 Related Links	19
6.6 Typical Characteristics	6	11.3 Community Resources	19
7 Detailed Description	8	11.4 Trademarks	19
7.1 Overview	8	11.5 Electrostatic Discharge Caution	19
7.2 Functional Block Diagram	8	11.6 Glossary	19
7.3 Feature Description	9	12 Mechanical, Packaging, and Orderable Information	19

4 Revision History

NOTE: Page numbers for previous revisions may differ from page numbers in the current version.

Changes from Revision E (May 2011) to Revision F	Page
• Added <i>Device Information</i> , <i>ESD Ratings</i> , <i>Recommended Operating Conditions</i> , and <i>Thermal Information</i> tables, and <i>Feature Description</i> , <i>Application and Implementation</i> , <i>Power Supply Recommendations</i> , <i>Layout</i> , <i>Device and Documentation Support</i> , and <i>Mechanical, Packaging, and Orderable Information</i> sections	1
• Added new automotive qualification features bullet, and deleted old bullet	1
• Changed <i>Applications</i> bullets	1
• Changed text in <i>Description</i> section	1
• Changed all figures to show correct device names; added -Q1	1
• Added pin names to all figures and removed all pin numbers	1
• Deleted Ordering Information table; information available in the Package Option Addendum at the end of this data sheet	3
• Deleted lead temperature and thermal resistance from <i>Absolute Maximum Ratings</i> table; see new <i>Thermal Information</i> table for thermal resistance values	3
• Changed $R_{\theta JA}$ value	4
• Changed V_S to V_+ throughout data sheet for consistency	5
• Changed R_{OUT} in <i>Electrical Characteristics</i> table to R_L for consistency	5
• Changed R_L from 125 k Ω to 25 k Ω in condition line of <i>Typical Characteristics</i> section	6
• Changed V_{IN} to V_{SENSE} in Figure 4	6
• Changed V_S to R_S when describing shunt resistor in <i>Operation</i> section	9
• Changed Figure 9; deleted incorrect pin numbers, and moved embedded table to outside of figure	10
• Changed Figure 10	11
• Changed Figure 14 to show correct pin names, deleted incorrect pin numbers, and added missing division line in output offset equation	14
• Changed Figure 15	15

5 Pin Configuration and Functions

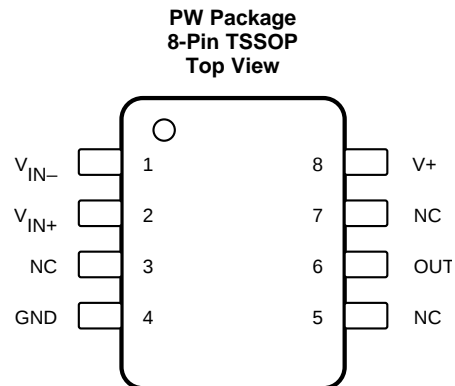

PIN		I/O	DESCRIPTION
NAME	NO.		
GND	4	—	Ground
NC	3, 5, 7	—	Not connected internally
OUT	6	O	Output current
V+	8	I	Power supply voltage
V _{IN+}	2	I	Positive input voltage
V _{IN-}	1	I	Negative input voltage

6 Specifications

6.1 Absolute Maximum Ratings

over operating free-air temperature range (unless otherwise noted) ⁽¹⁾

			MIN	MAX	UNIT	
Voltage	Supply, V+	INA139-Q1	-0.3	60	V	
		INA169-Q1	-0.3	75	V	
	Analog inputs, V _{IN+} , V _{IN-}	Common mode	INA139-Q1	-0.3	60	V
			INA169-Q1	-0.3	75	V
		Differential, (V _{IN+}) – (V _{IN-})		-40	2	V
	Analog output, OUT		-0.3	40	V	
Temperature	Operating, T _A		-55	125	°C	
	Junction, T _J			150	°C	
	Storage, T _{stg}		-65	150	°C	

(1) Stresses beyond those listed under *Absolute Maximum Ratings* may cause permanent damage to the device. These are stress ratings only, and functional operation of the device at these or any other conditions beyond those indicated under *recommended operating conditions* is not implied. Exposure to absolute-maximum-rated conditions for extended periods may affect device reliability.

6.2 ESD Ratings

			VALUE	UNIT
V _(ESD)	Electrostatic discharge	Human-body model (HBM), per AEC Q100-002 ⁽¹⁾	±2000	V
		Charged-device model (CDM), per AEC Q100-011	±1000	

(1) AEC Q100-002 indicates that HBM stressing shall be in accordance with the ANSI/ESDA/JEDEC JS-001 specification.

6.3 Recommended Operating Conditions

over operating free-air temperature range (unless otherwise noted)

		MIN	NOM	MAX	UNIT
Supply voltage, V+	INA139-Q1	2.7	5	40	V
	INA169-Q1	2.7	5	60	V
Common mode voltage	INA139-Q1	2.7	12	40	V
	INA169-Q1	2.7	12	60	V
Operating temperature, T _A		–40		125	°C

6.4 Thermal Information

THERMAL METRIC ⁽¹⁾		INA1x9-Q1		UNIT
		PW (TSSOP)		
		8 PINS		
R _{θJA}	Junction-to-ambient thermal resistance	179.1		°C/W
R _{θJC(top)}	Junction-to-case (top) thermal resistance	62.6		°C/W
R _{θJB}	Junction-to-board thermal resistance	107.7		°C/W
ψ _{JT}	Junction-to-top characterization parameter	7		°C/W
ψ _{JB}	Junction-to-board characterization parameter	106		°C/W
R _{θJC(bot)}	Junction-to-case (bottom) thermal resistance	N/A		°C/W

(1) For more information about traditional and new thermal metrics, see the *Semiconductor and IC Package Thermal Metrics* application report, [SPRA953](#).

6.5 Electrical Characteristics

at $T_A = -40^\circ\text{C}$ to $+125^\circ\text{C}$, $V_+ = 5\text{ V}$, $V_{IN+} = 12\text{ V}$, and $R_L = 25\text{ k}\Omega$ (unless otherwise noted)

PARAMETER	TEST CONDITIONS	INA139-Q1			INA169-Q1			UNIT
		MIN	TYP	MAX	MIN	TYP	MAX	
INPUT								
Full-scale sense voltage	$V_{SENSE} = V_{IN+} - V_{IN-}$		100	500		100	500	mV
Common-mode rejection	$V_{IN+} = 2.7\text{ V to }40\text{ V}$, $V_{SENSE} = 50\text{ mV}$	100	115					dB
	$V_{IN+} = 2.7\text{ V to }60\text{ V}$, $V_{SENSE} = 50\text{ mV}$				100	120		
Offset voltage ⁽¹⁾ RTI			± 0.2	± 2		± 0.2	± 2	mV
Offset voltage vs temperature			1			1		$\mu\text{V}/^\circ\text{C}$
Offset voltage vs power supply (V_+)	$V_{IN+} = 2.7\text{ V to }40\text{ V}$, $V_{SENSE} = 50\text{ mV}$		0.5	10				$\mu\text{V}/\text{V}$
	$V_{IN+} = 2.7\text{ V to }60\text{ V}$, $V_{SENSE} = 50\text{ mV}$					0.1	10	
Input bias current			10			10		μA
OUTPUT								
Transconductance	$V_{SENSE} = 10\text{ mV to }150\text{ mV}$	980	1000	1020	980	1000	1020	$\mu\text{A}/\text{V}$
Transconductance versus temperature	$V_{SENSE} = 100\text{ mV}$		10			10		$\text{nA}/^\circ\text{C}$
Nonlinearity error	$V_{SENSE} = 10\text{ mV to }150\text{ mV}$		$\pm 0.01\%$	$\pm 0.2\%$		$\pm 0.01\%$	$\pm 0.2\%$	
Total output error	$V_{SENSE} = 100\text{ mV}$		$\pm 0.5\%$	$\pm 2\%$		$\pm 0.5\%$	$\pm 2\%$	
Output impedance				$1 \parallel 5$			$1 \parallel 5$	$\text{G}\Omega \parallel \text{pF}$
Voltage output swing to power supply (V_+)			$(V_+) - 0.9$	$(V_+) - 1.2$		$(V_+) - 0.9$	$(V_+) - 1.2$	V
Voltage output swing to common mode, V_{CM}			$V_{CM} - 0.6$	$V_{CM} - 1$		$V_{CM} - 0.6$	$V_{CM} - 1$	V
FREQUENCY RESPONSE								
Bandwidth	$R_L = 10\text{ k}\Omega$		440			440		kHz
	$R_L = 20\text{ k}\Omega$		220			220		
Settling time (0 1%)	5 V step, $R_L = 10\text{ k}\Omega$		2.5			2.5		μs
	5 V step, $R_L = 20\text{ k}\Omega$		5			5		
NOISE								
Output-current noise density			20			20		$\text{pA}/\sqrt{\text{Hz}}$
Total output-current noise	$\text{BW} = 100\text{ kHz}$		7			7		nA RMS
POWER SUPPLY								
Quiescent current	$V_{SENSE} = 0\text{ V}$, $I_O = 0\text{ mA}$		60	125		60	125	μA

(1) Defined as the amount of input voltage, V_{SENSE} , to drive the output to zero.

6.6 Typical Characteristics

at $T_A = 25^\circ\text{C}$, $V_+ = 5\text{ V}$, $V_{IN+} = 12\text{ V}$, and $R_L = 25\text{ k}\Omega$ (unless otherwise noted)

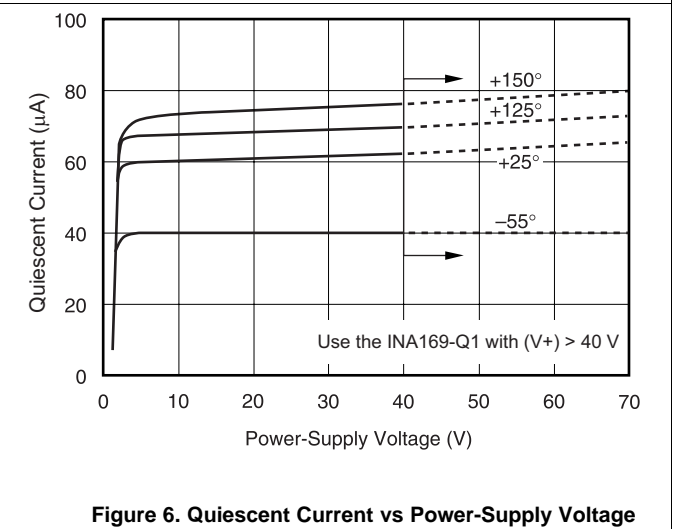
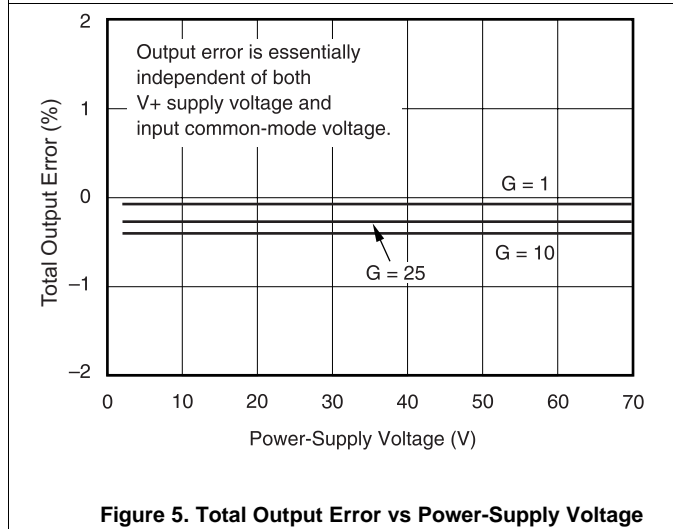
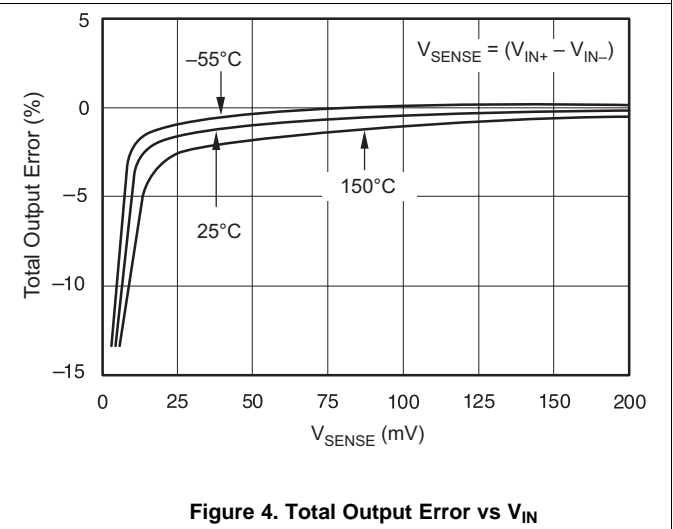
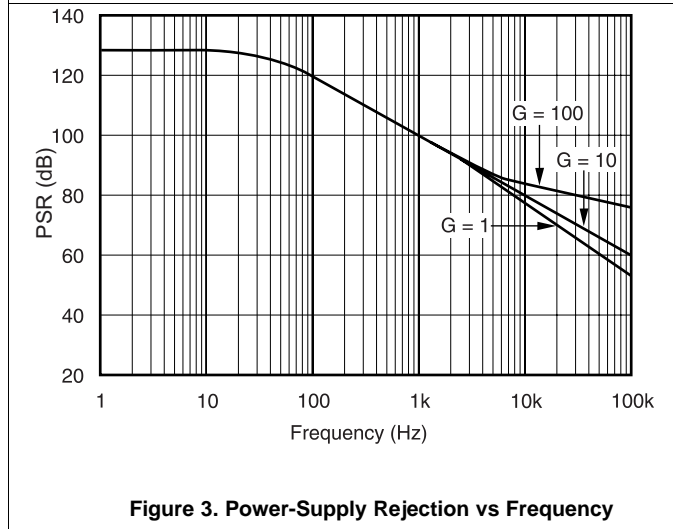
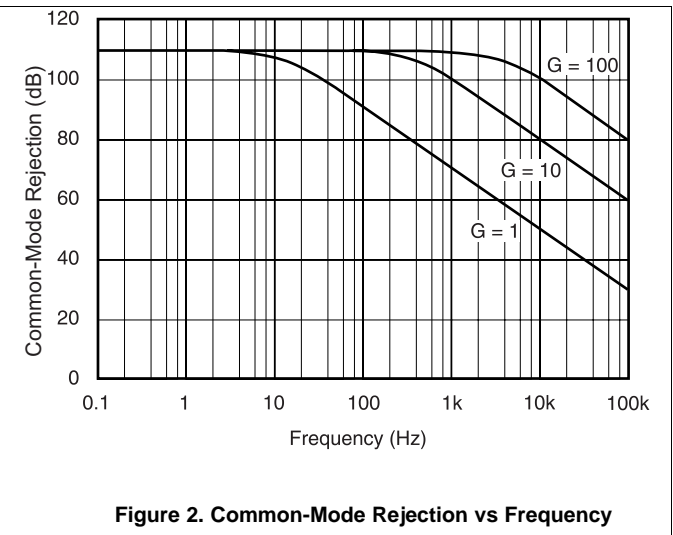
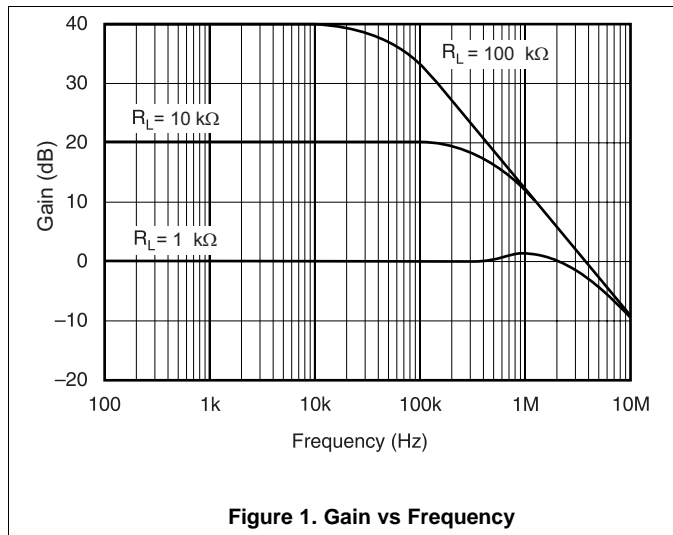

Typical Characteristics (continued)

at $T_A = 25^\circ\text{C}$, $V_+ = 5\text{ V}$, $V_{IN+} = 12\text{ V}$, and $R_L = 25\text{ k}\Omega$ (unless otherwise noted)

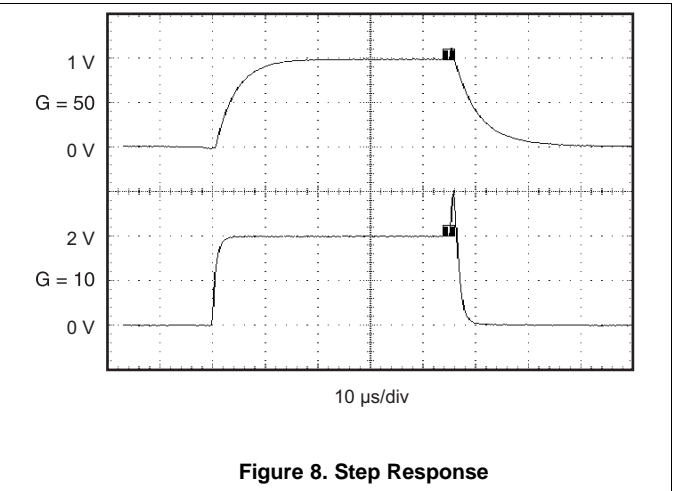
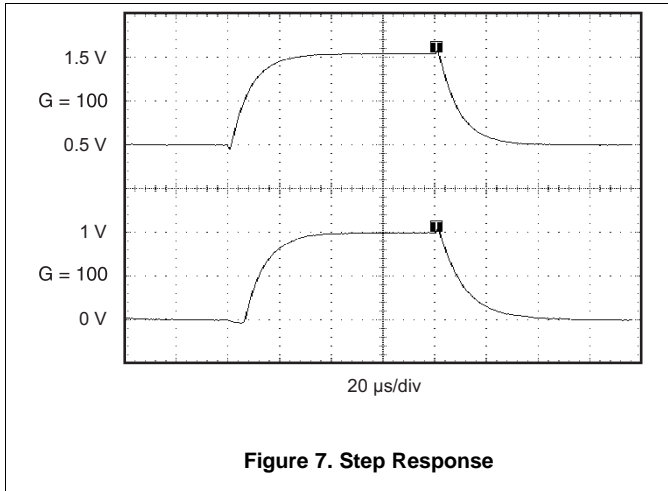

7 Detailed Description

7.1 Overview

The INA139-Q1 and INA169-Q1 devices (INA1x9-Q1) are comprised of a high voltage, precision operational amplifier, precision thin film resistors trimmed in production to an absolute tolerance and a low noise output transistor. The INA1x9-Q1 are powered from a single power supply, and the input voltages can exceed the power-supply voltage. The INA1x9-Q1 are ideal for measuring small differential voltages, such as those generated across a shunt resistor in the presence of large, common-mode voltages. The [Functional Block Diagram](#) illustrates the functional components within both the INA139-Q1 and INA169-Q1 devices.

7.2 Functional Block Diagram

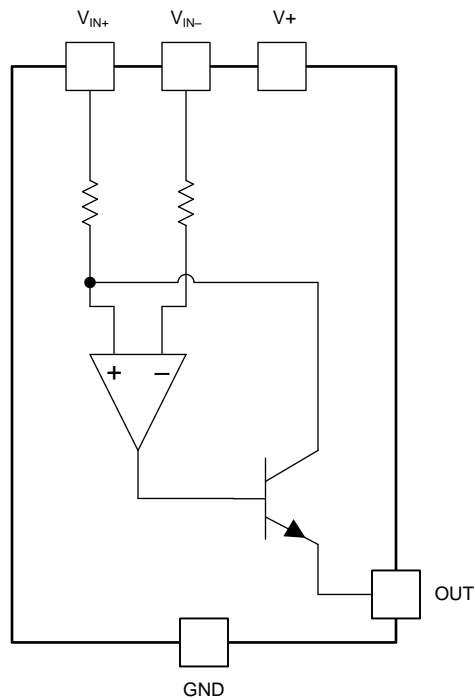

7.3 Feature Description

7.3.1 Output Voltage Range

The output of the INA1x9-Q1 is a current that is converted to a voltage by the load resistor, R_L . The output current remains accurate within the compliance voltage range of the output circuitry. The shunt voltage and the input common-mode and power-supply voltages limit the maximum possible output swing. The maximum output voltage ($V_{OUT\ MAX}$) compliance is limited by either [Equation 1](#) and [Equation 2](#), whichever is lower:

$$V_{OUT\ MAX} = (V+) - 0.7\ V - (V_{IN+} - V_{IN-}) \quad (1)$$

or

$$V_{OUT\ MAX} = V_{IN-} - 0.5\ V \quad (2)$$

7.3.2 Bandwidth

Measurement bandwidth is affected by the value of the load resistor, R_L . High gain produced by high values of R_L yields a narrower measurement bandwidth (see the [Typical Characteristics](#) section). For the widest possible bandwidth, keep the capacitive load on the output to a minimum. Reduction in bandwidth due to capacitive load is shown in the [Typical Characteristics](#).

If bandwidth limiting (filtering) is desired, add a capacitor can be added to the output (see [Figure 12](#)). This capacitor does not cause instability.

7.4 Device Functional Modes

For proper operation, the INA1x9-Q1 must operate within the specified limits. Operating either device outside of their specified power supply voltage range, or their specified common-mode range, results in unexpected behavior, and is not recommended. Additionally, operating the output beyond the specified limits, with respect to power supply voltage and input common-mode voltage, also produces unexpected results. See the [Electrical Characteristics](#) for the device specifications.

8 Application and Implementation

NOTE

Information in the following applications sections is not part of the TI component specification, and TI does not warrant its accuracy or completeness. TI's customers are responsible for determining suitability of components for their purposes. Customers should validate and test their design implementation to confirm system functionality.

8.1 Application Information

8.1.1 Operation

[Figure 9](#) illustrates the basic circuit diagram for both the INA139-Q1 and INA169-Q1. Load current I_S is drawn from supply V_P through shunt resistor R_S . The voltage drop in shunt resistor R_S is forced across $RG1$ by the internal op amp, causing current to flow into the collector of Q1. External resistor R_L converts the output current, I_O , to a voltage, V_{OUT} , at the OUT pin. The transfer function for the INA1x9-Q1 is given by [Equation 3](#):

$$I_O = g_m (V_{IN+} - V_{IN-})$$

where

- where $g_m = 1000\ \mu A/V$. (3)

In the circuit of [Figure 9](#), the input voltage ($V_{IN+} - V_{IN-}$) is equal to $I_S \times R_S$ and the output voltage (V_{OUT}) is equal to $I_O \times R_L$. The transconductance (g_m) of the INA1x9-Q1 is $1000\ \mu A/V$. The complete transfer function for the current measurement amplifier in this application is given by [Equation 4](#):

$$V_{OUT} = (I_S) (R_S) (1000\ \mu A/V) (R_L) \quad (4)$$

The maximum differential input voltage for accurate measurements is 0.5 V, producing a 500- μA output current. A differential input voltage of up to 2 V does not cause damage. Differential measurements (V_{IN+} and V_{IN-} pins) must be unipolar, with a more-positive voltage applied to the V_{IN+} pin. If a more-negative voltage is applied to V_{IN+} pin, I_O goes to zero, but no damage occurs.

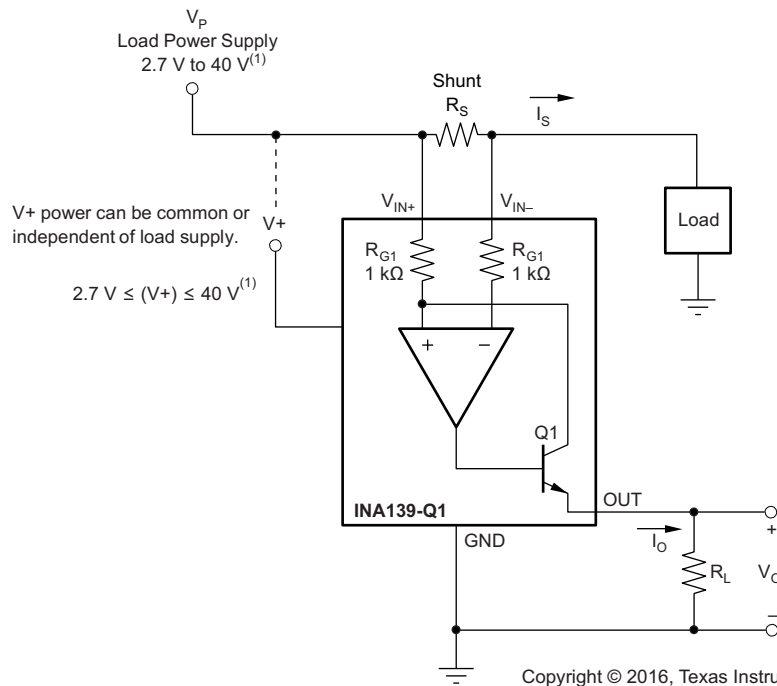
Application Information (continued)

(1) Maximum V_p and V_+ voltage is 60 V with INA169-Q1.

Figure 9. Basic Circuit Connections

Table 1. Voltage Gains and Corresponding Load-Resistor Values

VOLTAGE GAIN	EXACT R_L (k Ω)	NEAREST 1% R_L (k Ω)
1	1	1
2	2	2
5	5	4.99
10	10	10
20	20	20
50	50	49
100	100	100

8.2 Typical Applications

The INA1x9-Q1 are designed for current-shunt measurement circuits, as shown in Figure 9, but the basic function is useful in a wide range of circuitry. With a little creativity, many unforeseen uses are found in measurement and level shifting circuits. A few ideas are illustrated in the following subsections.

8.2.1 Buffering Output to Drive an ADC

Digitize the output of the INA139-Q1 or INA169-Q1 devices using a 1-MSPS analog-to-digital converter (ADC).

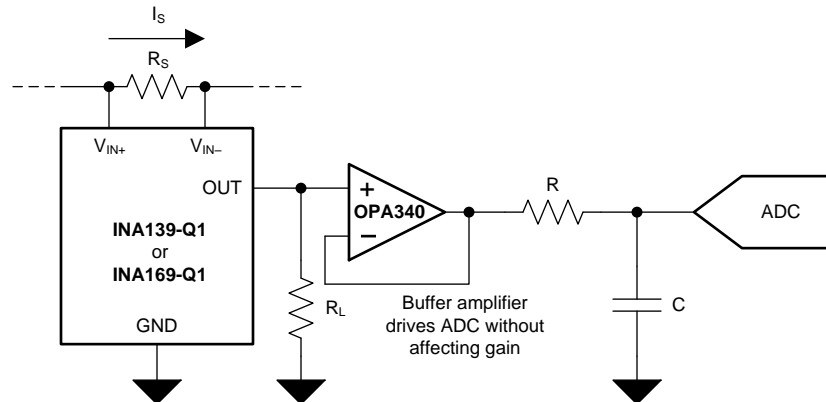

Figure 10. Buffering Output to Drive an ADC

8.2.1.1 Design Requirements

For this design example, use the input parameters shown in Table 2.

Table 2. Design Parameters

DESIGN PARAMETER	EXAMPLE VALUE
Supply voltage, V+	5 V
Common-mode voltage, V _{CM}	INA139-Q1: 2.7 V to 40 V
	INA169-Q1: 2.7 V to 60 V
Full-scale shunt voltage, V _{SENSE}	50 mV to 100 mV
Load resistor, R _L	1 kΩ to 100 kΩ

8.2.1.2 Detailed Design Procedure

8.2.1.2.1 Selecting R_S and R_L

In Figure 10, the value chosen for the shunt resistor, R_S, depends on the application and is a compromise between small-signal accuracy and maximum permissible voltage loss in the measurement line. High values of R_S provide better accuracy at lower currents by minimizing the effects of offset, while low values of R_S minimize voltage loss in the supply line. For most applications, best performance is attained with an R_S value that provides a full-scale shunt voltage range of 50 mV to 100 mV. Maximum input voltage for accurate measurements is 500 mV.

Choose an R_L that provides the desired full-scale output voltage. The output impedance of the INA1x9-Q1 OUT pin is very high, permitting the use of R_L values up to 100 kΩ with excellent accuracy. The input impedance of any additional circuitry at the output must be much higher than the value of R_L to avoid degrading accuracy.

Some ADCs have input impedances that significantly affect measurement gain. The input impedance of the A/D converter can be included as part of the effective R_L if its input can be modeled as a resistor to ground. Alternatively, an op amp can be used to buffer the ADC input, as shown in Figure 10. The INA1x9-Q1 are current output devices, and as such have an inherently large output impedance. The output currents from the amplifier are converted to an output voltage using the load resistor, R_L, connected from the amplifier output to ground. The ratio of the load resistor value to that of the internal resistor value determines the voltage gain of the system.

In many applications, digitizing the output of the INA1x9-Q1 is required. Digitizing is accomplished by connecting the output of the amplifier to an ADC. It is very common for an ADC to have a dynamic input impedance. If the INA1x9-Q1 output is connected directly to an ADC input, the input impedance of the ADC is effectively connected in parallel with gain setting resistor R_L . This parallel impedance combination affects the gain of the system and the impact on the gain is difficult to estimate accurately. A simple solution that eliminates the paralleling of impedances, and simplifies the gain of the circuit is to place a buffer amplifier, such as the [OPA340](#), between the output of the INA1x9-Q1 and the input to the ADC.

[Figure 10](#) illustrates this concept. Notice that a low-pass filter is placed between the OPA340 output and the input to the ADC. The filter capacitor is required to provide any instantaneous demand for current required by the input stage of the ADC. The filter resistor is required to isolate the OPA340 output from the filter capacitor in order to maintain circuit stability. The values for the filter components vary according to the operational amplifier used for the buffer and the particular ADC selected. More information regarding the design of the low-pass filter is found in the TI Precision Design, *16 bit 1MSPS Data Acquisition Reference Design for Single-Ended Multiplexed Applications*, [TIPD173](#).

[Figure 11](#) shows the expected results when driving an ADC at 1 MSPS with and without buffering the INA1x9-Q1 output. Without the buffer, the high impedance of the INA1x9-Q1 reacts with the input capacitance and sample-and-hold capacitance of the ADC, and does not allow the sampled value to reach the correct final value before the ADC is reset, and the next conversion starts. Adding the buffer amplifier significantly reduces the output impedance driving the sample-and-hold circuitry, and allows for higher conversion rates.

8.2.1.3 Application Curve

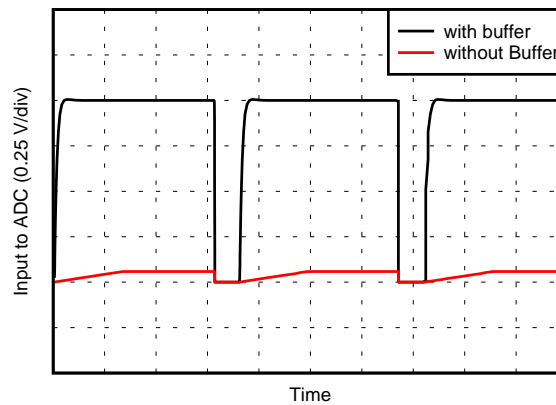

Figure 11. Driving an ADC With and Without a Buffer

8.2.2 Output Filter

Filter the output of the INA139-Q1 or INA169-Q1 devices.

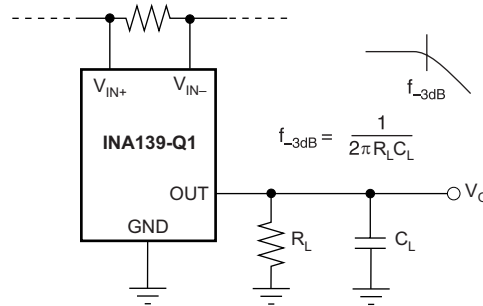

Figure 12. Output Filter

8.2.2.1 Design Requirements

For this design example, use the input parameters shown in Table 3.

Table 3. Design Parameters

DESIGN PARAMETER	EXAMPLE VALUE
Supply voltage, V+	INA139-Q1: 0 V to 40 V
	INA169-Q1: 0 V to 60 V
Common-mode voltage, V _{CM}	INA139-Q1: 0 V to 40 V
	INA169-Q1: 0 V to 60 V
Full-scale shunt voltage, V _{SENSE}	50 mV to 100 mV
Load resistor, R _L	1 kΩ to 100 kΩ

8.2.2.2 Detailed Design Procedure

A low-pass filter can be formed at the output of the INA1x9-Q1 simply by placing a capacitor of the desired value in parallel with the load resistor. First, determine the value of the load resistor needed to achieve the desired gain by using Table 1. Next, determine the capacitor value that results in the desired cutoff frequency according to the equation shown in Figure 12. Figure 13 shows the frequency response with different R_L values and a fixed filter capacitor.

8.2.2.3 Application Curve

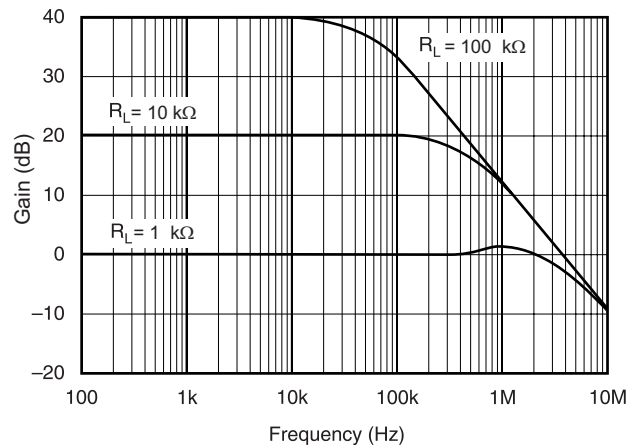
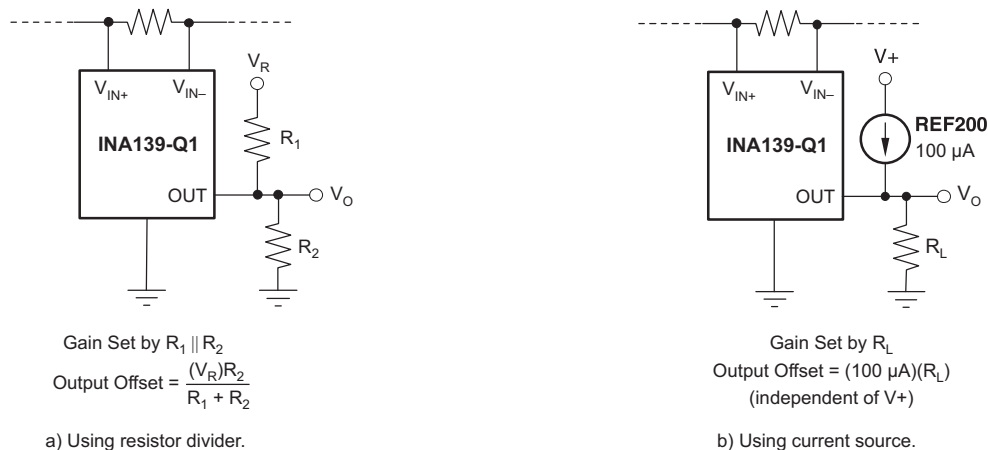

Figure 13. Gain vs Frequency

8.2.3 Offsetting the Output Voltage

For many applications using only a single power supply, the output voltage may have to be level shifted away from ground when there is no load current flowing in the shunt resistor. Level shifting the output of the INA1x9-Q1 is easily accomplished by one of two simple methods shown in Figure 14. Method (a) on the left-hand side of Figure 14 illustrates a simple voltage divider method. This method is useful for applications that require the output of the INA1x9-Q1 to remain centered with respect to the power supply at a zero load current through the shunt resistor. Using this method, the gain is determined by the parallel combination of R_1 and R_2 , while the output offset is determined by the voltage divider ratio of R_1 and R_2 , as shown in Figure 14(a). For applications that require a fixed value of output offset independent of the power supply voltage, use current-source method (b), shown on the right-hand side of Figure 14. With this method, a REF200 constant current source is used to generate a constant output offset. Using his method, the gain is determined by R_L , and the offset is determined by the product of the value of the current source and R_L .



Copyright © 2016, Texas Instruments Incorporated

Figure 14. Offsetting the Output Voltage

8.2.4 Bipolar Current Measurement

Configure the INA1x9-Q1 as shown in Figure 15 for applications where bidirectional current measurement is required. Two INA1x9-Q1 devices are required; connect the inputs across the shunt resistor as shown in Figure 15. A comparator, such as the TLV3201, is used to detect the polarity of the load current. The magnitude of the load current is monitored across the resistor connected between ground and the connection labeled *Output*. In this example, the 20-k Ω resistor results in a gain of 20 V/V. The 10-k Ω resistors connected in series with the INA1x9-Q1 output current are used to develop a voltage across the comparator inputs. Two diodes are required to prevent current flow into the INA1x9-Q1 output because only one device at a time provides current to the *Output* connection of the circuit. The circuit functionality is illustrated in Figure 16.

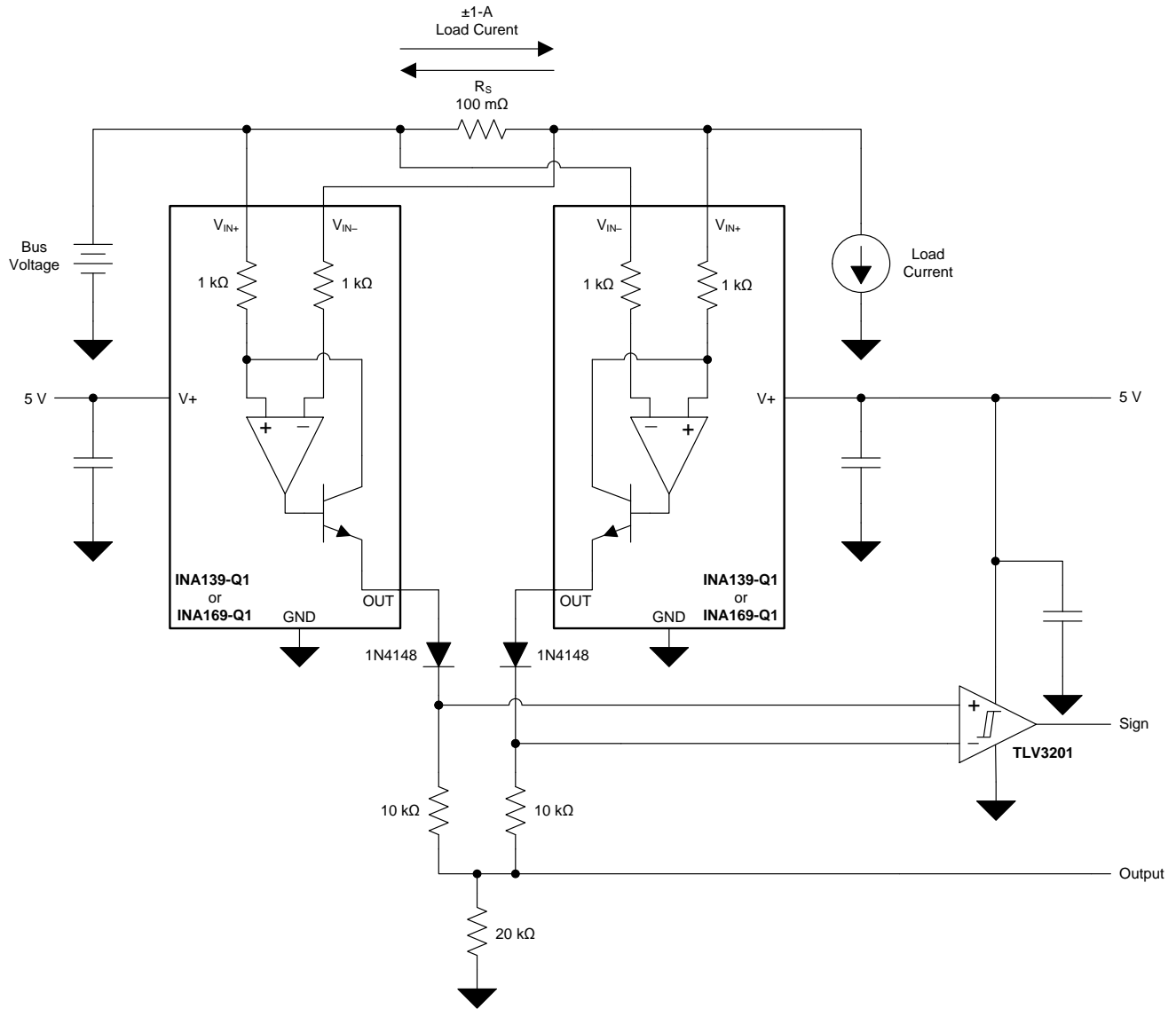

Figure 15. Bipolar Current Measurement

8.2.4.1 Application Curve

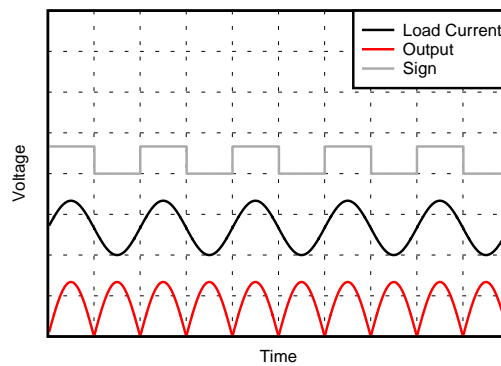

Figure 16. Bipolar Current Measurement Results (Arbitrary Scale)

8.2.5 Bipolar Current Measurement Using Differential Input of the ADC

Use the INA1x9-Q1 with an ADC, such as the [ADS7870](#), programmed for differential-mode operation; [Figure 17](#) illustrates this configuration. In this configuration, the use of two INA138-Q1s or INA168-Q1s allows for bidirectional current measurement. Depending on the polarity of the current, one of the INA devices provides an output voltage, while the other INA device output is zero. In this way, the ADC reads the polarity of current directly, without the need for additional circuitry.

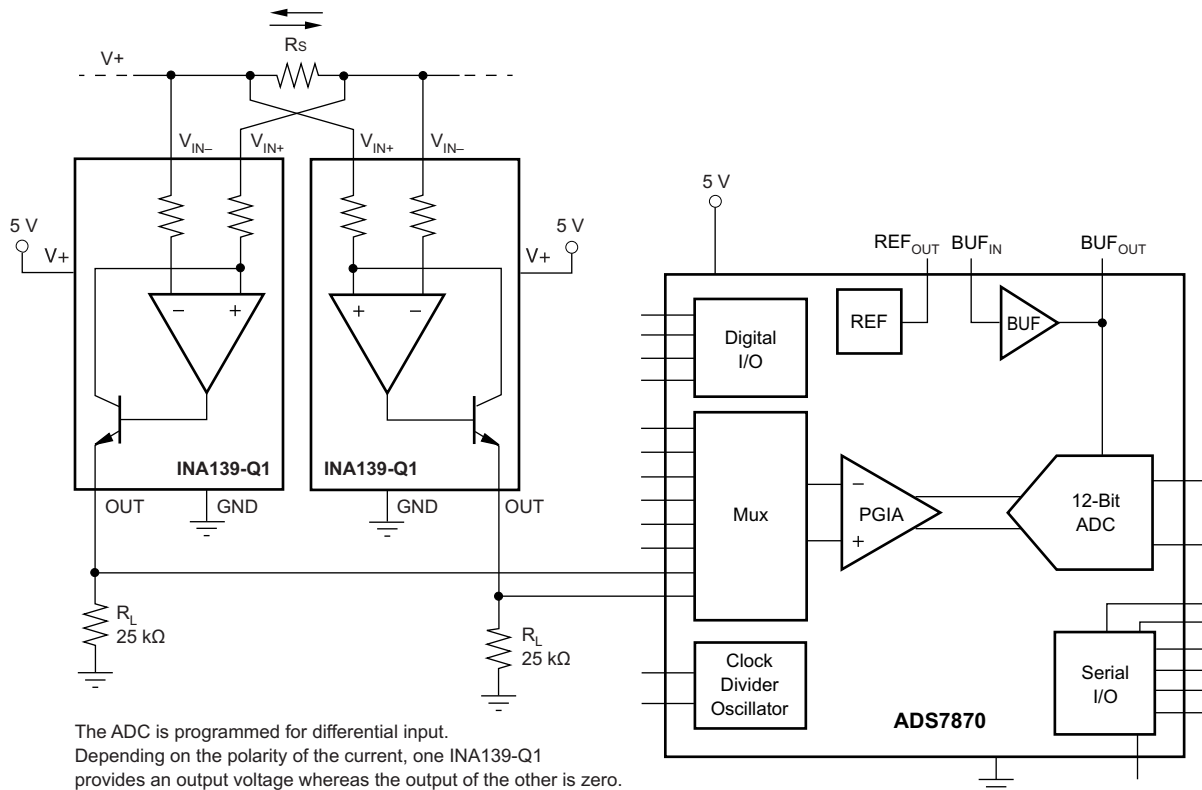

Figure 17. Bipolar Current Measurement Using Differential Input of the ADC

8.2.6 Multiplexed Measurement Using Logic Signal for Power

Measure multiple loads as shown in Figure 18. In this configuration, each INA1x9-Q1 device is powered by the digital I/O from the ADS7870. Multiplexing is achieved by switching on or off each desired I/O.

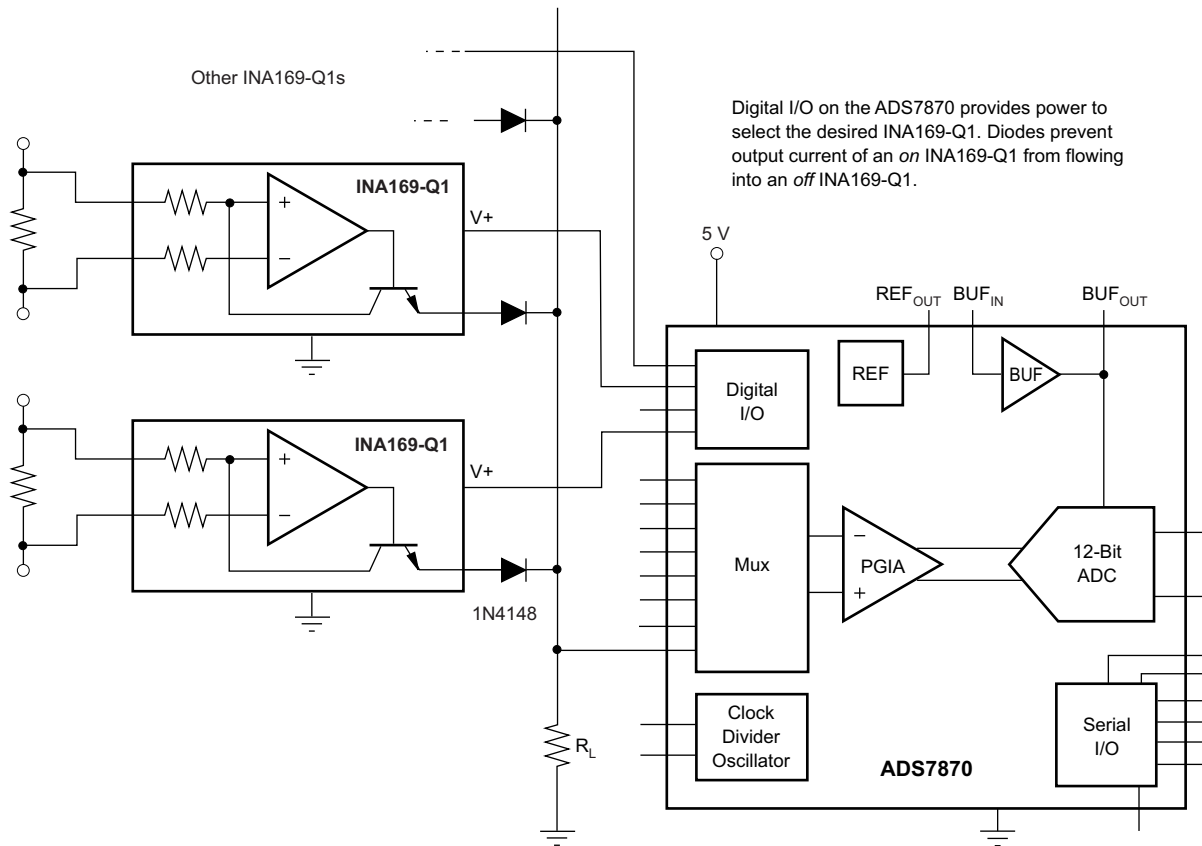

Figure 18. Multiplexed Measurement Using Logic Signal for Power

9 Power Supply Recommendations

The input circuitry of the INA1x9-Q1 can accurately measure beyond its power-supply voltage, $V+$. For example, the $V+$ power supply can be 5 V, whereas the load power-supply voltage goes up to 36 V with the INA138-Q1, or 60 V with the INA168-Q1. However, the output voltage range of the OUT pin is limited by the lesser of the two voltages (see the [Output Voltage Range](#) section). Place a 0.1- μ F capacitor near the $V+$ pin on the INA1x9-Q1. Additional capacitance may be required for applications with noisy supply voltages.

10 Layout

10.1 Layout Guidelines

[Figure 9](#) shows the basic connection of the INA1x9-Q1. Connect input pins V_{IN+} and V_{IN-} as closely as possible to the shunt resistor to minimize any resistance in series with the shunt resistance. Output resistor R_L is shown connected between the OUT pin and ground. Best accuracy is achieved with the output voltage measured directly across R_L . Measuring directly across R_L is especially important in high-current systems where load current could flow in the ground connections and affect measurement accuracy.

No power-supply bypass capacitors are required for stability of the INA1x9-Q1. However, applications with noisy or high-impedance power supplies may require decoupling capacitors to reject power-supply noise. Connect bypass capacitors close to the device pins.

10.2 Layout Example

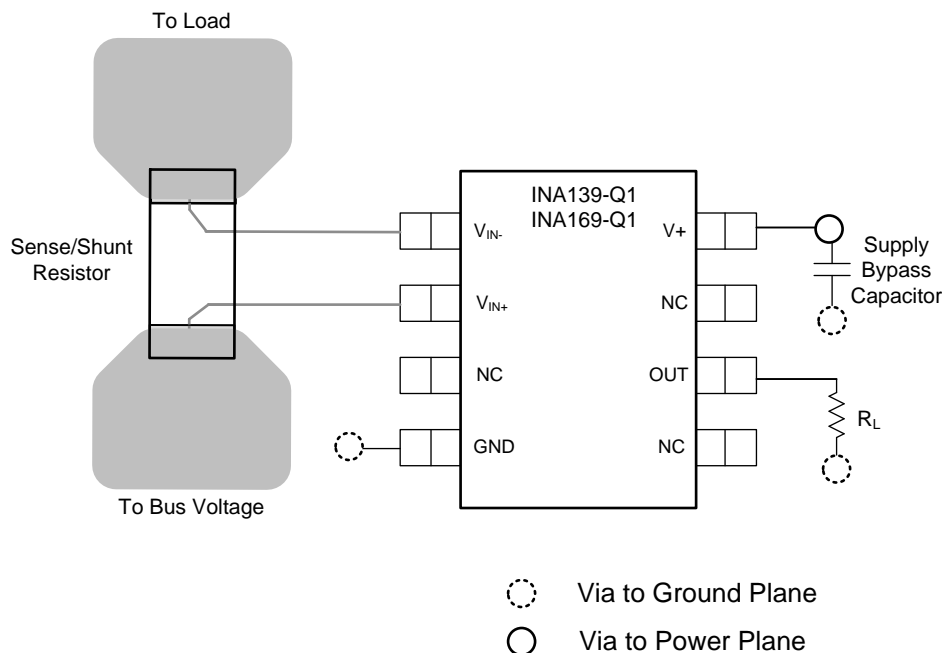

Figure 19. Typical Layout Example

11 Device and Documentation Support

11.1 Related Documentation

- TI Precision Design, *16 bit 1MSPS Data Acquisition Reference Design for Single-Ended Multiplexed Applications*, [TIPD173](#).

11.2 Related Links

[Table 4](#) lists quick access links. Categories include technical documents, support and community resources, tools and software, and quick access to sample or buy.

Table 4. Related Links

PARTS	PRODUCT FOLDER	SAMPLE & BUY	TECHNICAL DOCUMENTS	TOOLS & SOFTWARE	SUPPORT & COMMUNITY
INA139-Q1	Click here	Click here	Click here	Click here	Click here
INA169-Q1	Click here	Click here	Click here	Click here	Click here

11.3 Community Resources

The following links connect to TI community resources. Linked contents are provided "AS IS" by the respective contributors. They do not constitute TI specifications and do not necessarily reflect TI's views; see TI's [Terms of Use](#).

TI E2E™ Online Community *TI's Engineer-to-Engineer (E2E) Community*. Created to foster collaboration among engineers. At e2e.ti.com, you can ask questions, share knowledge, explore ideas and help solve problems with fellow engineers.

Design Support *TI's Design Support* Quickly find helpful E2E forums along with design support tools and contact information for technical support.

11.4 Trademarks

E2E is a trademark of Texas Instruments.
All other trademarks are the property of their respective owners.

11.5 Electrostatic Discharge Caution



These devices have limited built-in ESD protection. The leads should be shorted together or the device placed in conductive foam during storage or handling to prevent electrostatic damage to the MOS gates.

11.6 Glossary

[SLYZ022](#) — *TI Glossary*.

This glossary lists and explains terms, acronyms, and definitions.

12 Mechanical, Packaging, and Orderable Information

The following pages include mechanical, packaging, and orderable information. This information is the most current data available for the designated devices. This data is subject to change without notice and revision of this document. For browser-based versions of this data sheet, refer to the left-hand navigation.

PACKAGING INFORMATION

Orderable Device	Status (1)	Package Type	Package Drawing	Pins	Package Qty	Eco Plan (2)	Lead finish/ Ball material (6)	MSL Peak Temp (3)	Op Temp (°C)	Device Marking (4/5)	Samples
INA139QPWRQ1	ACTIVE	TSSOP	PW	8	2000	RoHS & Green	NIPDAU	Level-1-260C-UNLIM	-40 to 125	INA139	Samples
INA169QPWRQ1	ACTIVE	TSSOP	PW	8	2000	RoHS & Green	NIPDAU	Level-2-260C-1 YEAR	-40 to 125	INA169	Samples

(1) The marketing status values are defined as follows:

ACTIVE: Product device recommended for new designs.

LIFEBUY: TI has announced that the device will be discontinued, and a lifetime-buy period is in effect.

NRND: Not recommended for new designs. Device is in production to support existing customers, but TI does not recommend using this part in a new design.

PREVIEW: Device has been announced but is not in production. Samples may or may not be available.

OBSOLETE: TI has discontinued the production of the device.

(2) **RoHS:** TI defines "RoHS" to mean semiconductor products that are compliant with the current EU RoHS requirements for all 10 RoHS substances, including the requirement that RoHS substance do not exceed 0.1% by weight in homogeneous materials. Where designed to be soldered at high temperatures, "RoHS" products are suitable for use in specified lead-free processes. TI may reference these types of products as "Pb-Free".

RoHS Exempt: TI defines "RoHS Exempt" to mean products that contain lead but are compliant with EU RoHS pursuant to a specific EU RoHS exemption.

Green: TI defines "Green" to mean the content of Chlorine (Cl) and Bromine (Br) based flame retardants meet JS709B low halogen requirements of <=1000ppm threshold. Antimony trioxide based flame retardants must also meet the <=1000ppm threshold requirement.

(3) MSL, Peak Temp. - The Moisture Sensitivity Level rating according to the JEDEC industry standard classifications, and peak solder temperature.

(4) There may be additional marking, which relates to the logo, the lot trace code information, or the environmental category on the device.

(5) Multiple Device Markings will be inside parentheses. Only one Device Marking contained in parentheses and separated by a "~" will appear on a device. If a line is indented then it is a continuation of the previous line and the two combined represent the entire Device Marking for that device.

(6) Lead finish/Ball material - Orderable Devices may have multiple material finish options. Finish options are separated by a vertical ruled line. Lead finish/Ball material values may wrap to two lines if the finish value exceeds the maximum column width.

Important Information and Disclaimer:The information provided on this page represents TI's knowledge and belief as of the date that it is provided. TI bases its knowledge and belief on information provided by third parties, and makes no representation or warranty as to the accuracy of such information. Efforts are underway to better integrate information from third parties. TI has taken and continues to take reasonable steps to provide representative and accurate information but may not have conducted destructive testing or chemical analysis on incoming materials and chemicals. TI and TI suppliers consider certain information to be proprietary, and thus CAS numbers and other limited information may not be available for release.

In no event shall TI's liability arising out of such information exceed the total purchase price of the TI part(s) at issue in this document sold by TI to Customer on an annual basis.

OTHER QUALIFIED VERSIONS OF INA139-Q1, INA169-Q1 :

- Catalog: [INA139](#), [INA169](#)

NOTE: Qualified Version Definitions:

- Catalog - TI's standard catalog product

TAPE AND REEL INFORMATION

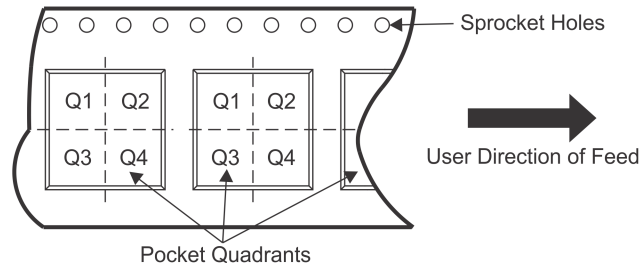
QUADRANT ASSIGNMENTS FOR PIN 1 ORIENTATION IN TAPE

*All dimensions are nominal

Device	Package Type	Package Drawing	Pins	SPQ	Reel Diameter (mm)	Reel Width W1 (mm)	A0 (mm)	B0 (mm)	K0 (mm)	P1 (mm)	W (mm)	Pin1 Quadrant
INA139QPWRQ1	TSSOP	PW	8	2000	330.0	12.4	7.0	3.6	1.6	8.0	12.0	Q1
INA169QPWRQ1	TSSOP	PW	8	2000	330.0	12.4	7.0	3.6	1.6	8.0	12.0	Q1

TAPE AND REEL BOX DIMENSIONS

*All dimensions are nominal

Device	Package Type	Package Drawing	Pins	SPQ	Length (mm)	Width (mm)	Height (mm)
INA139QPWRQ1	TSSOP	PW	8	2000	367.0	367.0	35.0
INA169QPWRQ1	TSSOP	PW	8	2000	367.0	367.0	35.0

PW0008A



PACKAGE OUTLINE
TSSOP - 1.2 mm max height

SMALL OUTLINE PACKAGE

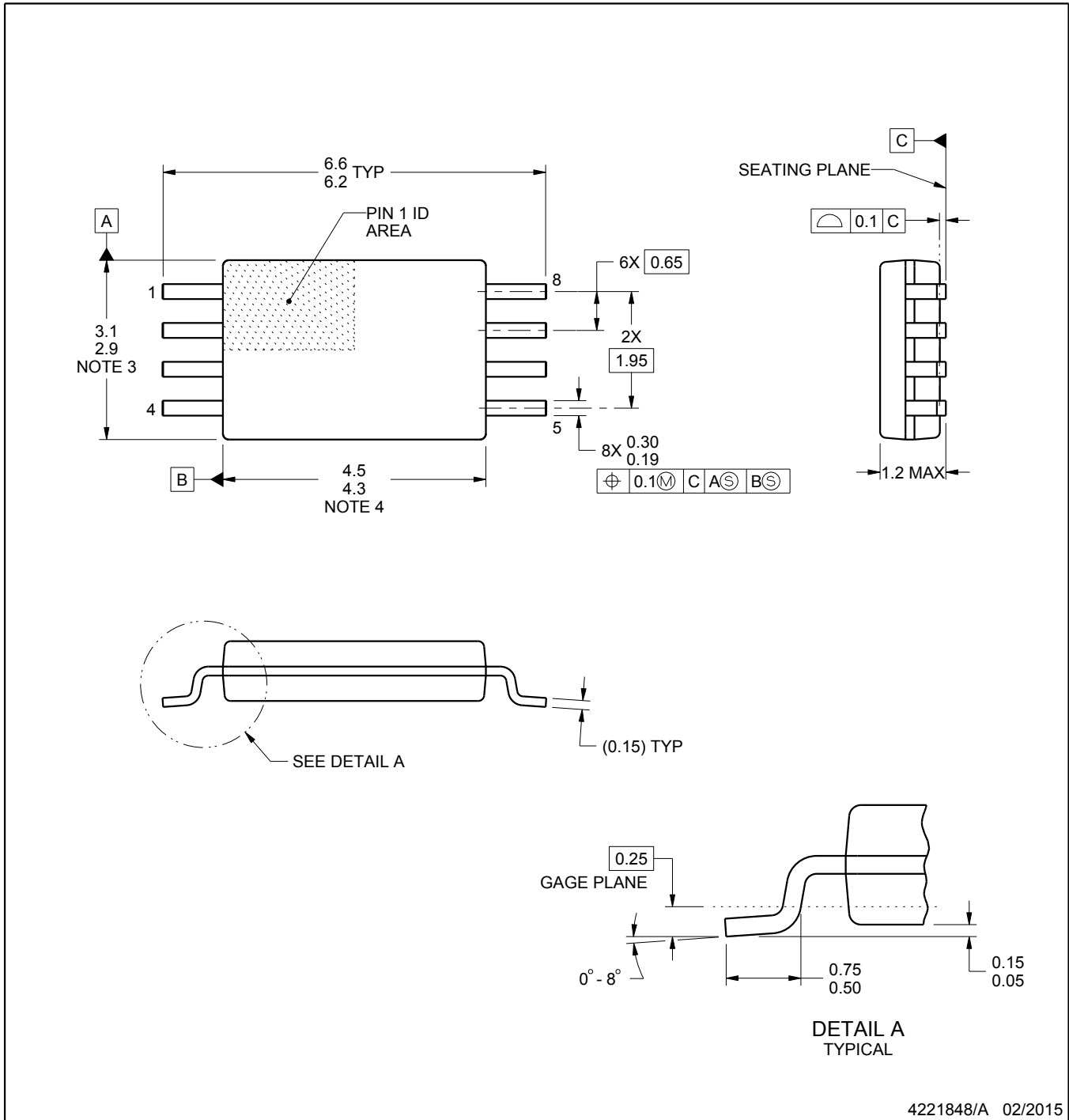

4221848/A 02/2015

NOTES:

1. All linear dimensions are in millimeters. Any dimensions in parenthesis are for reference only. Dimensioning and tolerancing per ASME Y14.5M.
2. This drawing is subject to change without notice.
3. This dimension does not include mold flash, protrusions, or gate burrs. Mold flash, protrusions, or gate burrs shall not exceed 0.15 mm per side.
4. This dimension does not include interlead flash. Interlead flash shall not exceed 0.25 mm per side.
5. Reference JEDEC registration MO-153, variation AA.

EXAMPLE BOARD LAYOUT

PW0008A

TSSOP - 1.2 mm max height

SMALL OUTLINE PACKAGE

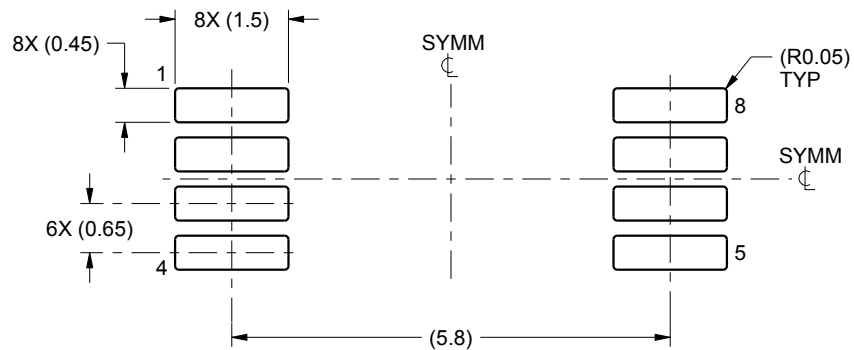

LAND PATTERN EXAMPLE
SCALE:10X

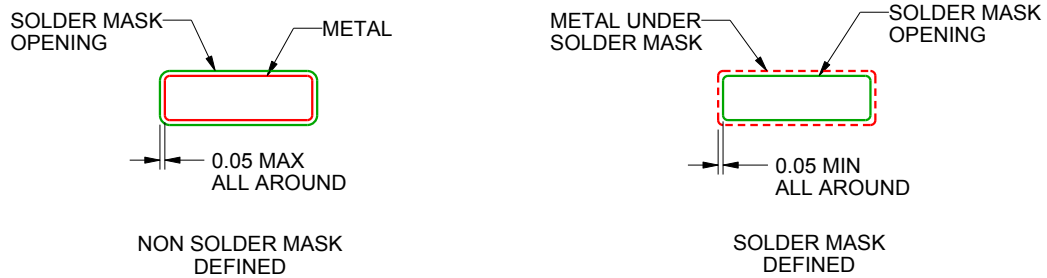

SOLDER MASK DETAILS
NOT TO SCALE

4221848/A 02/2015

NOTES: (continued)

- 6. Publication IPC-7351 may have alternate designs.
- 7. Solder mask tolerances between and around signal pads can vary based on board fabrication site.

EXAMPLE STENCIL DESIGN

PW0008A

TSSOP - 1.2 mm max height

SMALL OUTLINE PACKAGE

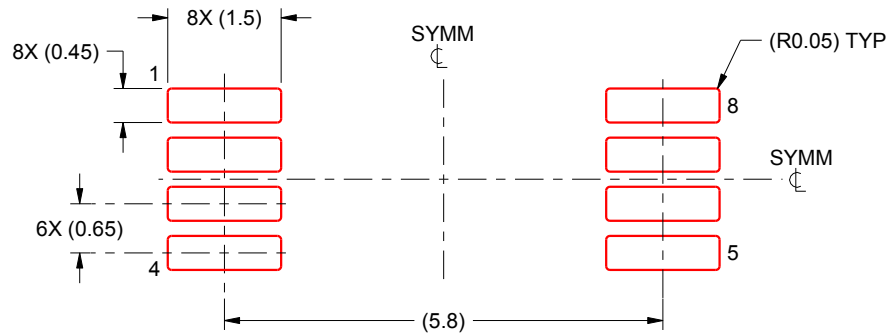

SOLDER PASTE EXAMPLE
BASED ON 0.125 mm THICK STENCIL
SCALE:10X

4221848/A 02/2015

NOTES: (continued)

8. Laser cutting apertures with trapezoidal walls and rounded corners may offer better paste release. IPC-7525 may have alternate design recommendations.
9. Board assembly site may have different recommendations for stencil design.

IMPORTANT NOTICE AND DISCLAIMER

TI PROVIDES TECHNICAL AND RELIABILITY DATA (INCLUDING DATASHEETS), DESIGN RESOURCES (INCLUDING REFERENCE DESIGNS), APPLICATION OR OTHER DESIGN ADVICE, WEB TOOLS, SAFETY INFORMATION, AND OTHER RESOURCES "AS IS" AND WITH ALL FAULTS, AND DISCLAIMS ALL WARRANTIES, EXPRESS AND IMPLIED, INCLUDING WITHOUT LIMITATION ANY IMPLIED WARRANTIES OF MERCHANTABILITY, FITNESS FOR A PARTICULAR PURPOSE OR NON-INFRINGEMENT OF THIRD PARTY INTELLECTUAL PROPERTY RIGHTS.

These resources are intended for skilled developers designing with TI products. You are solely responsible for (1) selecting the appropriate TI products for your application, (2) designing, validating and testing your application, and (3) ensuring your application meets applicable standards, and any other safety, security, or other requirements. These resources are subject to change without notice. TI grants you permission to use these resources only for development of an application that uses the TI products described in the resource. Other reproduction and display of these resources is prohibited. No license is granted to any other TI intellectual property right or to any third party intellectual property right. TI disclaims responsibility for, and you will fully indemnify TI and its representatives against, any claims, damages, costs, losses, and liabilities arising out of your use of these resources.

TI's products are provided subject to TI's Terms of Sale (www.ti.com/legal/termsofsale.html) or other applicable terms available either on ti.com or provided in conjunction with such TI products. TI's provision of these resources does not expand or otherwise alter TI's applicable warranties or warranty disclaimers for TI products.

Mailing Address: Texas Instruments, Post Office Box 655303, Dallas, Texas 75265
Copyright © 2020, Texas Instruments Incorporated