

TUSB1044 USB TYPE-C™ 10Gbps 多协议双向线性转接驱动器

1 特性

- 支持高达 10Gbps 数据速率的协议无关正反两用式 4 通道线性转接驱动器
 - 带有 USB 3.1 第 2 代和 DisplayPort 1.4 作为交替模式的 USB Type-C。
- 支持集成有 USB 3.1 和 DisplayPort 多路复用器，适用于 Type-C 应用的处理器
- 支持信号调节内部 Type-C 线缆
- 适用于 SBU 信号的交叉点多路复用器
- 频率为 4.05GHz 时，支持高达 11dB 的线性均衡功能
- 用于通道方向和均衡的 GPIO 和 I²C 控制
- 通过监控 USB 功耗状态和嗅探 DP 链路训练可实现高级电源管理
- 可通过 GPIO 或 I²C 进行配置
- 支持热插拔
- 3.3V 单电源
- 工业级温度范围：-40°C 至 85°C (TUSB1044I)
- 商业级温度范围：0°C 至 70°C (TUSB1044)
- 4mm x 6mm、0.4mm 间距、40 引脚 QFN 封装

2 应用

- 平板电脑
- 笔记本电脑
- 台式机
- 扩展坞

3 说明

TUSB1044 是一款支持高达 10Gbps 的数据速率的 USB Type-C 交替模式转接驱动器开关。该协议无关线性转接驱动器能够支持 USB Type-C 交替模式接口（包括 DisplayPort）。

TUSB1044 提供多个接收线性均衡级别，用于补偿由于电缆和电路板迹线损耗而产生的码间串扰 (ISI)。该器件由 3.3V 单电源供电，支持商业级和工业级温度范围。

TUSB1044 的全部四个通道均为正反两用式，这使其成为可用于诸多应用的多用途信号调节器。系统。

器件信息⁽¹⁾

器件型号	封装	封装尺寸 (标称值)
TUSB1044	WQFN (40)	4.00mm x 6.00mm
TUSB1044I	WQFN (40)	4.00mm x 6.00mm

(1) 如需了解所有可用封装，请参阅数据表末尾的可订购产品附录。

简化原理图

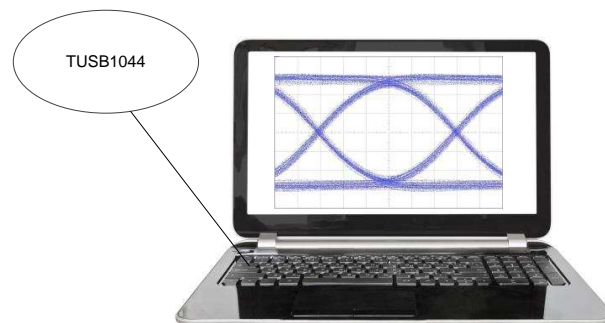
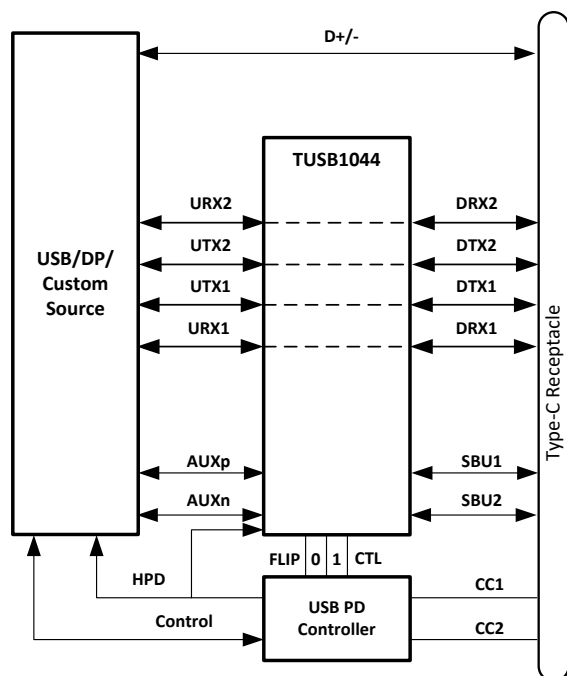

5 Pin Configuration and Functions

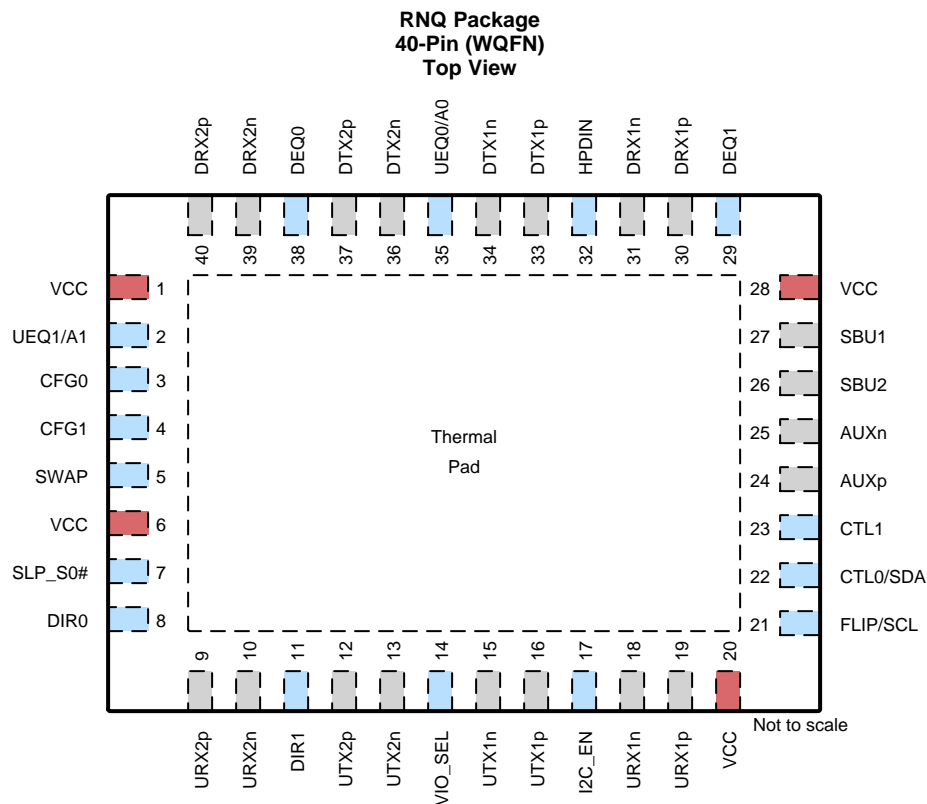

Pin Functions

PIN		I/O	DESCRIPTION
NO.	NAME		
1	VCC	P	3.3 V Power Supply
2	UEQ1/A1	4 Level I	This pin along with UEQ0 sets the high-frequency equalizer gain for upstream facing URX1, URX2, UTX1, UTX2 receivers. In I2C Mode, this pin will also set TUSB1044 I2C address. Refer to 表 9 .
3	CFG0	4 Level I	CFG0. This pin along with CFG1 will select VOD linearity range and DC gain for all the downstream and upstream channels. Refer to 表 8 for VOD linearity range and DC gain options.
4	CFG1	4 Level I	CFG1. This pin along with CFG0 will set VOD linearity range and DC gain for all the downstream and upstream channels. Refer to 表 8 for VOD linearity range and DC gain options.
5	SWAP	2 Level I (PD)	This pin swaps all the channel directions and EQ settings of downstream facing and upstream facing data path inputs. 0 – Do not swap channel directions and EQ settings (Default) 1. – Swap channel directions and EQ settings.
6	VCC	P	3.3V Power Supply
7	SLP_S0#	2 Level I (PD)	This pin when asserted low will disable Receiver Detect functionality. While this pin is low and TUSB1044 is in U2/U3, TUSB1044 will disable LOS and LFPS detection circuitry and RX termination for both channels will remain enabled. If this pin is low and TTUSB1044 is in Disconnect state, the RX detect functionality will be disabled and RX termination for both channels will be disabled. 0 – RX Detect disabled 1 – RX Detect enabled (Default)
8	DIR0	2 Level I (PD)	This pin along with DIR1 sets the data path signal direction format. Refer to 表 4 for signal direction formats. 0 - Source Side (DFP) Alt Mode format 1 - Sink Side (UFP) Alt Mode format
9	URX2p	Diff I/O	Differential positive input/output for upstream facing RX2 port.
10	URX2n	Diff I/O	Differential negative input/output for upstream facing RX2 port.
11	DIR1	2 Level I/O (PD)	This pin along with DIR0 sets the data path signal direction format. Refer to 表 4 for signal direction formats. 0 - DisplayPort Alt Mode format 1 - Custom Alt Mode format

Pin Functions (continued)

PIN		I/O	DESCRIPTION
NO.	NAME		
12	UTX2p	Diff I/O	Differential positive input/output for upstream facing TX2 port.
13	UTX2n	Diff I/O	Differential negative input/output for upstream facing TX2 port.
14	VIO_SEL	4 Level I/O	This pin selects I/O voltage levels for the 2-level GPIO configuration pins and the I2C interface: 0 = 3.3-V configuration I/O voltage, 3.3-V I ² C interface (Default) R = 3.3-V configuration I/O voltage, 1.8-V I ² C interface F = 1.8-V configuration I/O voltage, 3.3-V I ² C interface 1 = 1.8-V configuration I/O voltage, 1.8-V I ² C interface.
15	UTX1n	Diff I/O	Differential negative input/output for upstream facing TX1 port.
16	UTX1p	Diff I/O	Differential positive input/output for upstream facing TX1 port.
17	I2C_EN	4 Level I	I2C Programming or Pin Strap Programming Select. 0 = GPIO Mode, AUX Snoop Enabled (I ² C disabled) R = TI Test Mode (I ² C enabled) F = GPIO Mode, AUX Snoop Disabled (I ² C disabled) 1 = I2C enabled.
18	URX1n	Diff I/O	Differential negative input/output for upstream facing RX1 port.
19	URX1p	Diff I/O	Differential positive input/output for upstream facing RX1 port.
20	VCC	P	3.3V Power Supply
21	FLIP/SCL	2 Level I (PD) (Failsafe)	In GPIO mode, this is Flip control pin, otherwise this pin is I ² C clock.
22	CTL0/SDA	2 Level I (PD) (Failsafe)	In GPIO mode, this is a USB3.1 Switch control pin, otherwise this pin is I ² C data.
23	CTL1	2 Level I (PD)	DP Alt mode Switch Control Pin. In GPIO mode, this pin will enable or disable DisplayPort functionality. Otherwise DisplayPort functionality is enabled and disabled through I2C registers. L = DisplayPort Disabled. H = DisplayPort Enabled. In I2C Mode, this pin is not used by TUSB1044.
24	AUXp	I/O, CMOS	AUXp. DisplayPort AUX positive I/O connected to the DisplayPort source or sink through an AC coupling capacitor. In addition to AC coupling capacitor, this pin also requires a 100-kΩ resistor to GND between the AC coupling capacitor and the AUXp pin if the TUSB1044 is used on the DisplayPort source side, or a 1-MΩ resistor to DP_PWR (3.3V) between the AC coupling capacitor and the AUXp pin if TUSB1044 is used on the DisplayPort sink side. This pin along with AUXn is used by the TUSB1044 for AUX snooping and is routed to SBU1/2 based on the orientation of the Type-C plug.
25	AUXn	I/O, CMOS	AUXn. DisplayPort AUX I/O connected to the DisplayPort source or sink through an AC coupling capacitor. In addition to AC coupling capacitor, this pin also requires a 100-kΩ resistor to DP_PWR (3.3V) between the AC coupling capacitor and the AUXn pin if the TUSB1044 is used on the DisplayPort source side, or a 1-MΩ resistor to GND between the AC coupling capacitor and the AUXn pin if TUSB1044 is used on the DisplayPort sink side. This pin along with AUXp is used by the TUSB1044 for AUX snooping and is routed to SBU1/2 based on the orientation of the Type-C plug.
26	SBU2	I/O, CMOS	SBU2. When the TUSB1044 is used on the DisplayPort source side, this pin should be DC coupled to the SBU2 pin of the Type-C receptacle. When the TUSB1044 is used on the DisplayPort sink side, this pin should be DC coupled to the SBU1 pin of the Type-C receptacle. A 2-MΩ resistor to GND is also recommended.
27	SBU1	I/O, CMOS	SBU1. When the TUSB1044 is used on the DisplayPort source side, this pin should be DC coupled to the SBU1 pin of the Type-C receptacle. When the TUSB1044 is used on the DisplayPort sink side, this pin should be DC coupled to the SBU2 pin of the Type-C receptacle. A 2-MΩ resistor to GND is also recommended.
28	VCC	P	3.3V Power Supply
29	DEQ1	4 Level I	This pin along with DEQ0 sets the high-frequency equalizer gain for downstream facing DRX1, DRX2, DTX1, DTX2 receivers.
30	DRX1p	Diff I/O	Differential positive input/output for downstream facing RX1 port.
31	DRX1n	Diff I/O	Differential negative input/output for downstream facing RX1 port.
32	HPDIN	2 Level I (PD)	This pin is an input for Hot Plug Detect received from DisplayPort sink. When HPDIN is low for greater than 2ms, all DisplayPort lanes are disabled and AUX to SBU switch will remain closed. When HPDIN is high, the enabled DisplayPort lanes from AUX snoop or registers will be active.
33	DTX1p	Diff I/O	Differential positive input/output for downstream facing TX1 port.
34	DTX1n	Diff I/O	Differential negative input/output for downstream facing TX1 port.
35	UEQ0/A0	4 Level I	This pin along with UEQ1 sets the high-frequency equalizer gain for upstream facing URX1, URX2, UTX1, UTX2 receivers. In I2C mode, this pin will also set TUSB1044 I2C address. Refer to 表 9 .
36	DTX2n	Diff I/O	Differential negative input/output for downstream facing TX2 port.
37	DTX2p	Diff I/O	Differential positive input/output for downstream facing TX2 port.

Pin Functions (continued)

PIN		I/O	DESCRIPTION
NO.	NAME		
38	DEQ0	4 Level I	This pin along with DEQ1 sets the high-frequency equalizer gain for downstream facing URX1, URX2, UTX1, UTX2 receivers.
39	DRX2n	Diff I/O	Differential negative input/output for downstream facing RX2 port.
40	DRX2p	Diff I/O	Differential positive input/output for downstream facing RX2 port.
Thermal Pad		GND	Ground

6 Specifications

6.1 Absolute Maximum Ratings

over operating free-air temperature range (unless otherwise noted)⁽¹⁾

		MIN	MAX	UNIT
V_{CC}	Supply voltage range	-0.3	4	V
V_{IN_DIFF}	Differential voltage at differential input pins.		±2.5	V
V_{IN_SE}	Single-ended input voltage at differential input pins.	-0.5	4	V
V_{IN_CMOS}	Input voltage at CMOS inputs	-0.3	4	V
T_{stg}	Storage temperature	-65	150	°C

(1) Stresses beyond those listed under *Absolute Maximum Rating* may cause permanent damage to the device. These are stress ratings only, which do not imply functional operation of the device at these or any other conditions beyond those indicated under *Recommended Operating Condition*. Exposure to absolute-maximum-rated conditions for extended periods may affect device reliability.

6.2 ESD Ratings

		VALUE	UNIT
$V_{(ESD)}$	Electrostatic discharge	Human body model (HBM), per ANSI/ESDA/JEDEC JS-001, all pins ⁽¹⁾	±5000
		Charged device model (CDM), per JEDEC specification JESD22-C101, all pins ⁽²⁾	±1500

(1) JEDEC document JEP155 states that 500-V HBM allows safe manufacturing with a standard ESD control process.

(2) JEDEC document JEP157 states that 250-V CDM allows safe manufacturing with a standard ESD control process.

6.3 Recommended Operating Conditions

over operating free-air temperature range (unless otherwise noted)

		MIN	NOM	MAX	UNIT
V_{CC}	Supply voltage	3	3.3	3.6	V
V_{I2C}	Supply that external resistors on SDA and SCL are pulled up to.	1.7		3.6	V
V_{PSN}	Power supply noise on V_{CC}			100	mV
T_A	TUSB1044 Ambient temperature	0		70	°C
T_A	TUSB1044i Ambient temperature	-40		85	°C
T_J	TUSB1044 Junction temperature			105	°C
	TUSB1044i Junction temperature			125	°C

6.4 Thermal Information

THERMAL METRIC ⁽¹⁾		TUSB1044		UNIT
		RNQ (WQFN)		
		40 PINS		
$R_{\theta JA}$	Junction-to-ambient thermal resistance	37.6		°C/W
$R_{\theta JC(top)}$	Junction-to-case (top) thermal resistance	20.7		°C/W
$R_{\theta JB}$	Junction-to-board thermal resistance	9.5		°C/W
Ψ_{JT}	Junction-to-top characterization parameter	0.2		°C/W
Ψ_{JB}	Junction-to-board characterization parameter	9.4		°C/W
$R_{\theta JC(bot)}$	Junction-to-case (bottom) thermal resistance	2.3		°C/W

(1) For more information about traditional and new thermal metrics, see the [Semiconductor and IC Package Thermal Metrics](#) application report.

6.5 Electrical Characteristics

over operating free-air temperature and voltage range (unless otherwise noted)

PARAMETER		TEST CONDITIONS	MIN	TYP	MAX	UNIT
Power						
P _{USB-ACTIVE}	Average power when configured for USB 3.1 only mode.	Link in U0 with GEN2 data transmission; EQ control pins = NC; K28.5 pattern at 10 Gbps; V _{ID} = 1000mVp-p; V _{OD} Linearity = 900mVp-p; CTL1 = L; CTL0 = H		297		mW
P _{USB-DP-ACTIVE}	Average power when configured for USB 3.1 and 2 lane DP.	Link in U0 with GEN2 data transmission and DP active; EQ control pins = NC; K28.5 pattern at 10 Gbps; V _{ID} = 1000mVp-p; V _{OD} Linearity = 900mVp-p; CTL1 = H; CTL0 = H		578		mW
P _{CUSTOM-ACTIVE}	Average power when configured for USB 3.1 and 2 channel custom alt mode.	Link in U0 with GEN2 data transmission and custom alt mode active; EQ control pins = NC; K28.5 pattern at 10 Gbps; V _{ID} = 1000mVp-p; V _{OD} Linearity = 900mVp-p; CTL1 = H; CTL0 = H		578		mW
P _{4DP-ACTIVE}	Average power when configured for Four DP lanes	Four active DP lanes; EQ control pins = NC; K28.5 pattern at 10 Gbps; V _{ID} = 1000mVp-p; V _{OD} Linearity = 900mVp-p; CTL1 = H; CTL0 = L		564		mW
P _{USB-NC}	Average power when configured for USB3.1 only and nothing connected to TXP/N pins.	No USB device connected; CTL1 = L; CTL0 = H		2.5		mW
P _{USB-U2U3}	Average power when configured for USB3.1 only and link in U2 or U3 state.	Link in U2 or U3 state; CTL1 = L; CTL0 = H		2		mW
P _{SHUTDOWN}	Average power when device in Shutdown	CTL1 = L; CTL0 = L; I2C_EN = 0;		0.65		mW
4-State CMOS Inputs(UEQ[1:0];DEQ[1:0], CFG[1:0], A[1:0], I2C_EN, VIO_SEL)						
I _{IH}	High-level input current	V _{CC} = 3.6 V; V _{IN} = 3.6 V	20		80	μA
I _{IL}	Low-level input current	V _{CC} = 3.6 V; V _{IN} = 0 V	-160		-40	μA
4-Level V _{TH}	Threshold 0 / R	V _{CC} = 3.3 V		0.55		V
	Threshold R/ Float	V _{CC} = 3.3 V		1.65		V
	Threshold Float / 1	V _{CC} = 3.3 V		2.7		V
R _{PU}	Internal pull up resistance			35		kΩ
R _{PD}	Internal pull-down resistance			95		kΩ
2-State CMOS Input (CTL0, CTL1, FLIP, HPDIN, SLP_S0#, SWAP, DIR[1:0]).						
V _{IH-3.3V}	High-level input voltage	V _{CC} = 3.3V; VIO_SEL = "0" or "R";	2		3.6	V
V _{IL-3.3V}	Low-level input voltage	V _{CC} = 3.3V; VIO_SEL = "0" or "R";	0		0.8	V
V _{IH-1.8V}	High-level input voltage	V _{CC} = 3.3V; VIO_SEL = "F" or "1";	1.2		3.6	V
V _{IL-1.8V}	Low-level input voltage	V _{CC} = 3.3V; VIO_SEL = "F" or "1";	0		0.4	V
R _{PD_CTL1}	Internal pull-down resistance for CTL1, CTL0, DIR0, DIR1, FLIP, SLP_S0#.			500		kΩ
R _{PD_HPDI}	Internal pull-down resistance for HPDIN			500		kΩ
R _{PD_SWAP}	Internal pull-down resistance for SWAP.			200		kΩ
I _{IH}	High-level input current	V _{IN} = 3.6 V	-25		25	μA
I _{IL}	Low-level input current	V _{IN} = GND, V _{CC} = 3.6 V	-25		25	μA
I2C Control Pins SCL, SDA						
V _{IH-3.3V}	High-level input voltage	V _{CC} = 3.3V; VIO_SEL = "0" or "R"; I2C Mode Enabled;	2		3.6	V
V _{IL-3.3V}	Low-level input voltage	V _{CC} = 3.3V; VIO_SEL = "0" or "R"; I2C Mode Enabled;	0		0.8	V

Electrical Characteristics (continued)

over operating free-air temperature and voltage range (unless otherwise noted)

PARAMETER		TEST CONDITIONS	MIN	TYP	MAX	UNIT
V _{IH-1.8V}	High-level input voltage	V _{CC} = 3.3V; VIO_SEL = "F" or "1"; I2C Mode Enabled;	1.2		3.6	V
V _{IL-1.8V}	Low-level input voltage	V _{CC} = 3.3V; VIO_SEL = "F" or "1"; I2C Mode Enabled;	0		0.4	V
V _{OL}	Low-level output voltage	I2C_EN ! = 0; I _{OL} = 3 mA	0		0.4	V
I _{OL}	Low-level output current	I2C_EN ! = 0; V _{OL} = 0.4 V	20			mA
I _{I_I2C}	Input current on SDA pin	0.1 * V _{I2C} < Input voltage < 3.3 V	-10		10	μA
C _{I_I2C}	Input capacitance		0.5		5	pF
USB Gen 2 Differential Receiver (UTX1P/N, UTX2P/N, DRX1P/N, DRX2P/N)						
V _{RX-DIFF-PP}	Input differential peak-peak voltage swing dynamic range	AC-coupled differential peak-to-peak signal measured post CTLE through a reference channel		2000		mVpp
V _{RX-DC-CM}	Common-mode voltage bias in the receiver (DC)			0		V
R _{RX-DIFF-DC}	Differential input impedance (DC)	Present after a GEN 2 device is detected on TXP/TXN	72		120	Ω
R _{RX-CM-DC}	Receiver DC Common Mode impedance	Present after a GEN 2 device is detected on TXP/TXN	18		30	Ω
Z _{RX-HIGH-IMP-DC-POS}	Common-mode input impedance with termination disabled (DC)	Present when no GEN 2 device is detected on TXP/TXN. Measured over the range of 0-500 mV with respect to GND.	25			kΩ
V _{SIGNAL-DET-DIFF-PP}	Input Differential peak-to-peak Signal Detect Assert Level	10 Gbps PRBS7 pattern; low loss input channel;		80		mV
V _{RX-IDLE-DET-DIFF-PP}	Input Differential peak-to-peak Signal Detect De-assert Level	10 Gbps PRBS7 pattern; low loss input channel;		60		mV
V _{RX-LFPS-DET-DIFF-PP}	Low-frequency Periodic Signaling (LFPS) Detect Threshold	Below the minimum is squelched.	100		300	mV
C _{RX}	RX input capacitance to GND	At 5 GHz			0.3	pF
RL _{RX-DIFF}	Differential Return Loss	50 MHz – 2.5 GHz at 90 Ω		-13		dB
RL _{RX-DIFF}		5 GHz at 90 Ω		-12		dB
RL _{RX-CM}	Common Mode Return Loss	50 MHz – 5 GHz at 90 Ω		-10.5		dB
EQ _{SSP}	Receiver equalization at maximum setting	UEQ[1:0] and DEQ[1:0]. at 5 GHz.		10		dB
USB Gen 2 Differential Transmitter (DTX1P/N, DTX2P/N, URX1P/N, URX2P/N)						
V _{TX-DIFF-PP}	Transmitter dynamic differential voltage swing range.			1500		mVpp
V _{TX-RCV-DETECT}	Amount of voltage change allowed during Receiver Detection	At 3.3 V			600	mV
V _{TX-CM-IDLE-DELTA}	Transmitter idle common-mode voltage change while in U2/U3 and not actively transmitting LFPS	measured at the connector side of the AC coupling caps with 50 ohm load	-600		600	mV
V _{TX-DC-CM}	Common-mode voltage bias in the transmitter (DC)			1.75	2.3	V
V _{TX-CM-AC-PP-ACTIVE}	Tx AC Common-mode voltage active	Rx EQ setting matches input channel loss; Max mismatch from Txp + Txn for both time and amplitude; -40°C to 85°C;			100	mVpp
V _{TX-IDLE-DIFF-AC-PP}	AC Electrical idle differential peak-to-peak output voltage	At package pins	0		10	mV

Electrical Characteristics (continued)

over operating free-air temperature and voltage range (unless otherwise noted)

PARAMETER		TEST CONDITIONS	MIN	TYP	MAX	UNIT
V _{TX-IDLE-DIFF-DC}	DC Electrical idle differential output voltage	At package pins after low-pass filter to remove AC component	0		14	mV
R _{TX-DIFF}	Differential impedance of the driver		75		120	Ω
C _{AC-COUPLING}	AC Coupling capacitor		75		265	nF
R _{TX-CM}	Common-mode impedance of the driver	Measured with respect to AC ground over 0-500 mV	18		30	Ω
I _{TX-SHORT}	TX short circuit current	TX + /- shorted to GND			74	mA
RL _{TX-DIFF}	Differential Return Loss	50 MHz – 2.5 GHz at 90 Ω		-13		dB
RL _{TX-DIFF}	Differential Return Loss	5 GHz at 90 Ω		-10.5		dB
RL _{TX-CM}	Common Mode Return Loss	50 MHz – 5 GHz at 90 Ω		-10		dB
AC Characteristics						
Crosstalk	Differential Cross Talk between TX and RX signal Pairs	At 5 GHz		-30		dB
G _{LF}	Low-frequency voltage gain for 0dB setting.	At 100 MHz; 200 mVpp < V _{ID} < 2000 mVpp; 0 dB DC Gain;	-1	0	1	dB
CP _{1 dB-LF-1100}	Low-frequency 1-dB compression point	At 100 MHz; 200 mVpp < V _{ID} < 2000 mVpp; 1100mVpp linearity setting;		1100		mVpp
CP _{1 dB-HF-1100}	High-frequency 1-dB compression point	At 5 GHz; 200 mVpp < V _{ID} < 2000 mVpp; 1100mVpp linearity setting;		1200		mVpp
f _{LF}	Low-frequency cutoff	200 mVpp < V _{ID} < 2000 mVpp		22	50	kHz
D _J	TX output deterministic jitter	200 mVpp < V _{ID} < 2000 mVpp, PRBS7, 10 Gbps		0.07		UIpp
D _J	TX output deterministic jitter	200 mVpp < V _{ID} < 2000 mVpp, PRBS7, 8.1 Gbps		0.07		UIpp
T _J	TX output total jitter	200 mVpp < V _{ID} < 2000 mVpp, PRBS7, 10 Gbps		0.11		UIpp
T _J	TX output total jitter	200 mVpp < V _{ID} < 2000 mVpp, PRBS7, 8.1 Gbps		0.11		UIpp
DisplayPort Receiver (UTX1P/N, UTX2P/N, URX1P/N, URX2P/N)						
V _{ID-PP}	Peak-to-peak input differential dynamic voltage range			1500		V
V _{IC}	Input Common Mode Voltage			0		V
C _{AC}	AC coupling capacitance		75		265	nF
EQ _{DP}	Receiver Equalizer	DPEQ1, DPEQ0 at 4.05 GHz		9.5		dB
d _R	Data rate	HBR3			8.1	Gbps
R _{ti}	Input Termination resistance		80	100	120	Ω
DisplayPort Transmitter (DTX1P/N, DTX2P/N, DRX1P/N, DRX2P/N)						
V _{TX-DIFFPP}	VOD dynamic range			1500		mV
AUXP/N and SBU1/2						
R _{ON}	Output ON resistance	V _{CC} = 3.3 V; V _I = 0 to 0.4 V for AUXP; V _I = 2.7 V to 3.6 V for AUXN		5	12	Ω
ΔR _{ON}	ON resistance mismatch within pair	V _{CC} = 3.3 V; V _I = 0 to 0.4 V for AUXP; V _I = 2.7 V to 3.6 V for AUXN			1.3	Ω
R _{ON-FLAT}	ON resistance flatness (R _{ON} max – R _{ON} min) measured at identical V _{CC} and temperature	V _{CC} = 3.3 V; V _I = 0 to 0.4 V for AUXP; V _I = 2.7 V to 3.6 V for AUXN			2	Ω
V _{AUXP-D C-CM}	AUX Channel DC common mode voltage for AUXP and SBU1.	V _{CC} = 3.3 V	0		0.4	V
V _{AUXN-D C-CM}	AUX Channel DC common mode voltage for AUXN and SBU2	V _{CC} = 3.3 V	2.7		3.6	V

6.6 Switching Characteristics

over operating free-air temperature range (unless otherwise noted)

PARAMETER	TEST CONDITIONS	MIN	TYP	MAX	UNIT
USB 3.1					
$t_{DLEEntry}$	Delay from U0 to electrical idle	Refer to 图 4	0.16		ns
$t_{DLEExit_U1}$	U1 exist time: break in electrical idle to the transmission of LFPS	Refer to 图 4	0.16		ns
$t_{DLEExit_U2U3}$	U2/U3 exit time: break in electrical idle to transmission of LFPS		5		μ s
t_{RXDET_INTVL}	RX detect interval while in Disconnect			12	ms
$t_{IDLEExit_DISC}$	Disconnect Exit Time		12		ms
$t_{Exit_SHUTDOWN}$	Shutdown Exit Time	CTL0 = Vcc/2 to U2U3	0.5		ms
t_{DIFF_DLY}	Differential Propagation Delay	Refer to 图 3		300	ps
$t_{PWRUPACTIVE}$	Time when Vcc reaches 70% to device active			1	ms
$t_{R/F}$	Output Rise/Fall Time	20%-80% of differential voltage measured 1.7 inch from the output pin; Input signal rise/fall faster than 35ps; Refer to 图 5	35		ps
t_{RF-MM}	Output Rise/Fall time mismatch	20%-80% of differential voltage measured 1.7 inch from the output pin		2.6	ps
AUXP/N and SBU1/2					
t_{AUX_PD}	Switch propagation delay	Refer to 图 3		1050	ps
$t_{AUX_SW_OFF}$	Switching time CTL1 to switch OFF.	Refer to 图 7		500	ns
$t_{AUX_SW_ON}$	Switching time CTL1 to switch ON	Refer to 图 6		500	ns
$t_{AUX_INTR A}$	Intra-pair output skew			100	ps

6.7 Timing Requirements

		MIN	NOM	MAX	UNIT
I2C Timing					
f_{SCL}	I2C clock frequency			1	MHz
t_{BUF}	Bus free time between START and STOP conditions	0.5			μ s
t_{HDSTA}	Hold time after repeated START condition. After this period, the first clock pulse is generated	0.26			μ s
t_{LOW}	Low period of the I2C clock	0.5			μ s
t_{HIGH}	High period of the I2C clock	0.26			μ s
t_{SUSTA}	Setup time for a repeated START condition	0.26			μ s
t_{HDDAT}	Data hold time	0			μ s
t_{SUDAT}	Data setup time	50			ns
t_R	Rise time of both SDA and SCL signals			120	ns
t_F	Fall time of both SDA and SCL signals	$20 \times (V_{I2C}/5.5 V)$		120	ns
t_{SUSTO}	Setup time for STOP condition	0.26			μ s
C_{BUS}	Capacitive load for each bus line			100	pF
HPDIN and CTL1					
$t_{CTL1_DEBOUNCE}$	CTL1 and HPDIN debounce time when transitioning from H to L. DP lanes will be disabled if low is greater than min value.	2.5			ms
USB3.1 and DisplayPort mode transition requirement GPIO mode					
$t_{GP_USB_4DP}$	Min overlap of CTL0 and CTL1 when transitioning from USB 3.1 only mode to 4-Lane DisplayPort mode or vice versa. Refer to 图 2	4			μ s
Power-on timings					
t_{d_pg}	$V_{CC(MIN)}$ to Internal power good asserted high. Refer to 图 8			500	μ s
t_{cfg_su}	CFG pins setup. Refer to 图 8	350			μ s
t_{cfg_hd}	CFG pin hold. Refer to 图 8	10			μ s
t_{ctl_db}	CTL[1:0] and FLIP pin debounce. Refer to 图 8			16	ms
t_{VCC_RAMP}	VCC supply ramp requirement. Refer to 图 8	0.1		100	ms



图 1. I2C Timing Diagram Definitions



图 2. USB3.1 to 4-Lane DisplayPort in GPIO Mode

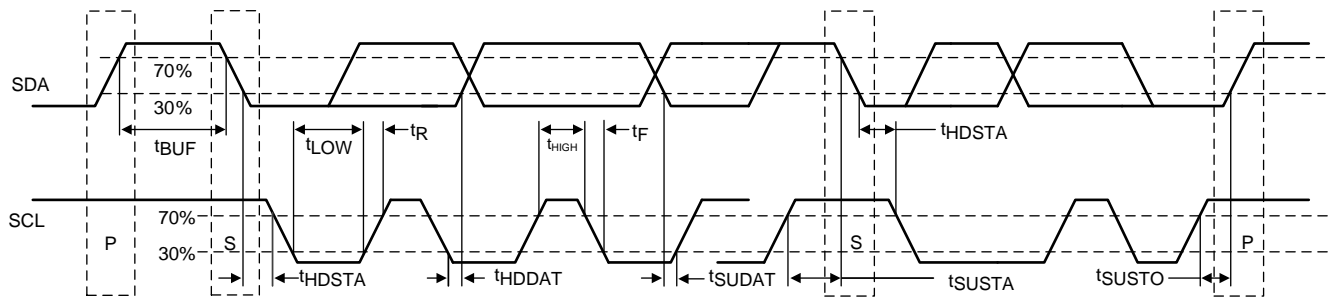

图 3. Propagation Delay

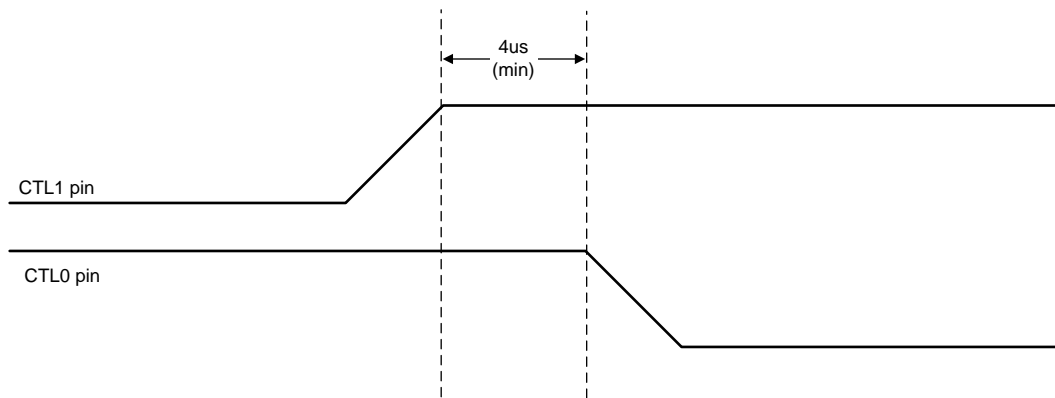

图 4. Electrical Idle Mode Exit and Entry Delay

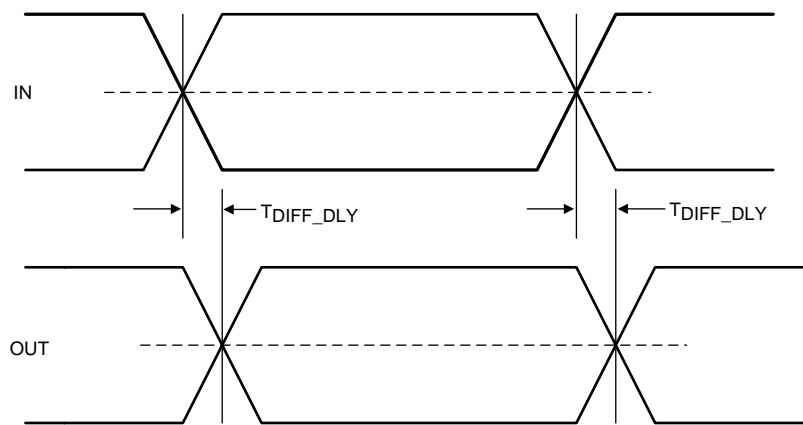

图 5. Output Rise and Fall Times

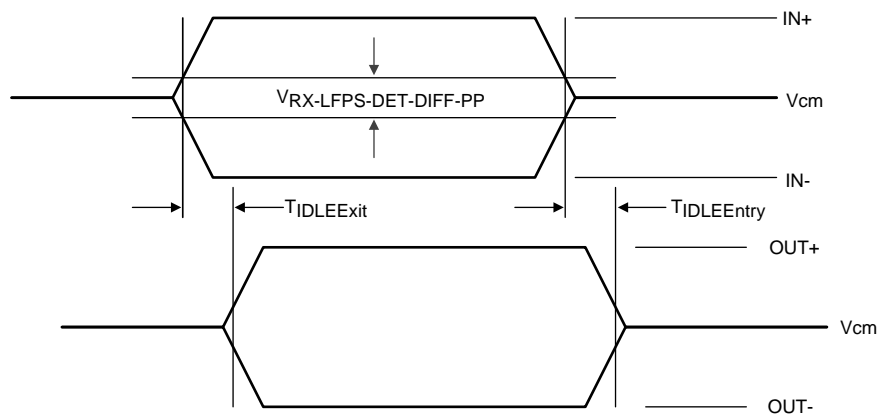

Copyright © 2017, Texas Instruments Incorporated

图 6. AUX to SBU Switch ON Timing Diagram

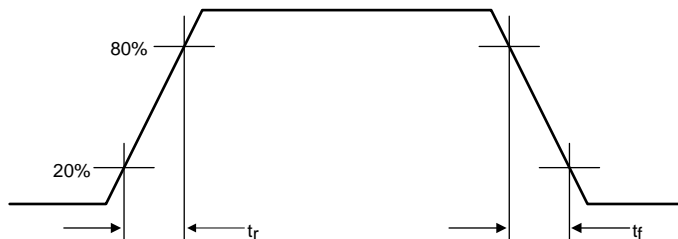
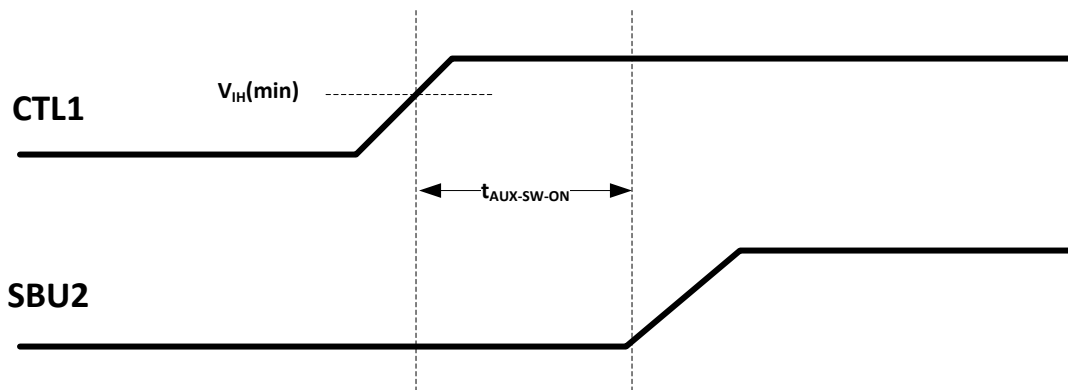
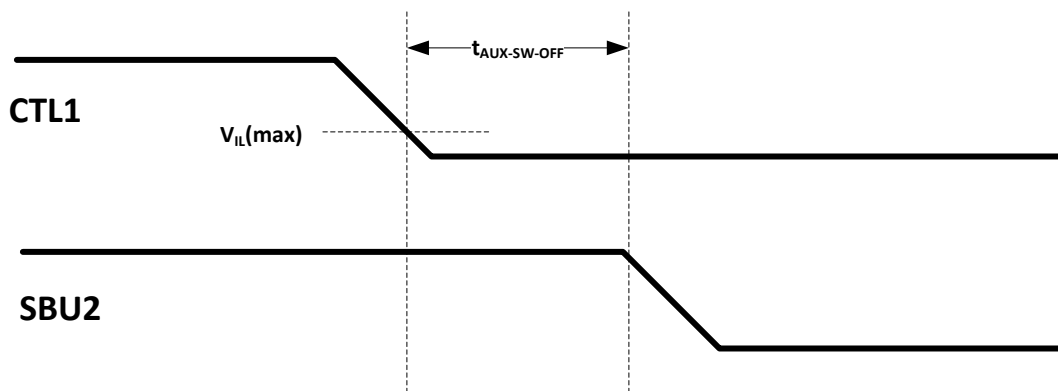

Copyright © 2017, Texas Instruments Incorporated

图 7. AUX to SBU Switch OFF Timing Diagram



图 8. Power-Up Timing Diagram

6.8 Typical Characteristics



Typical Characteristics (接下页)

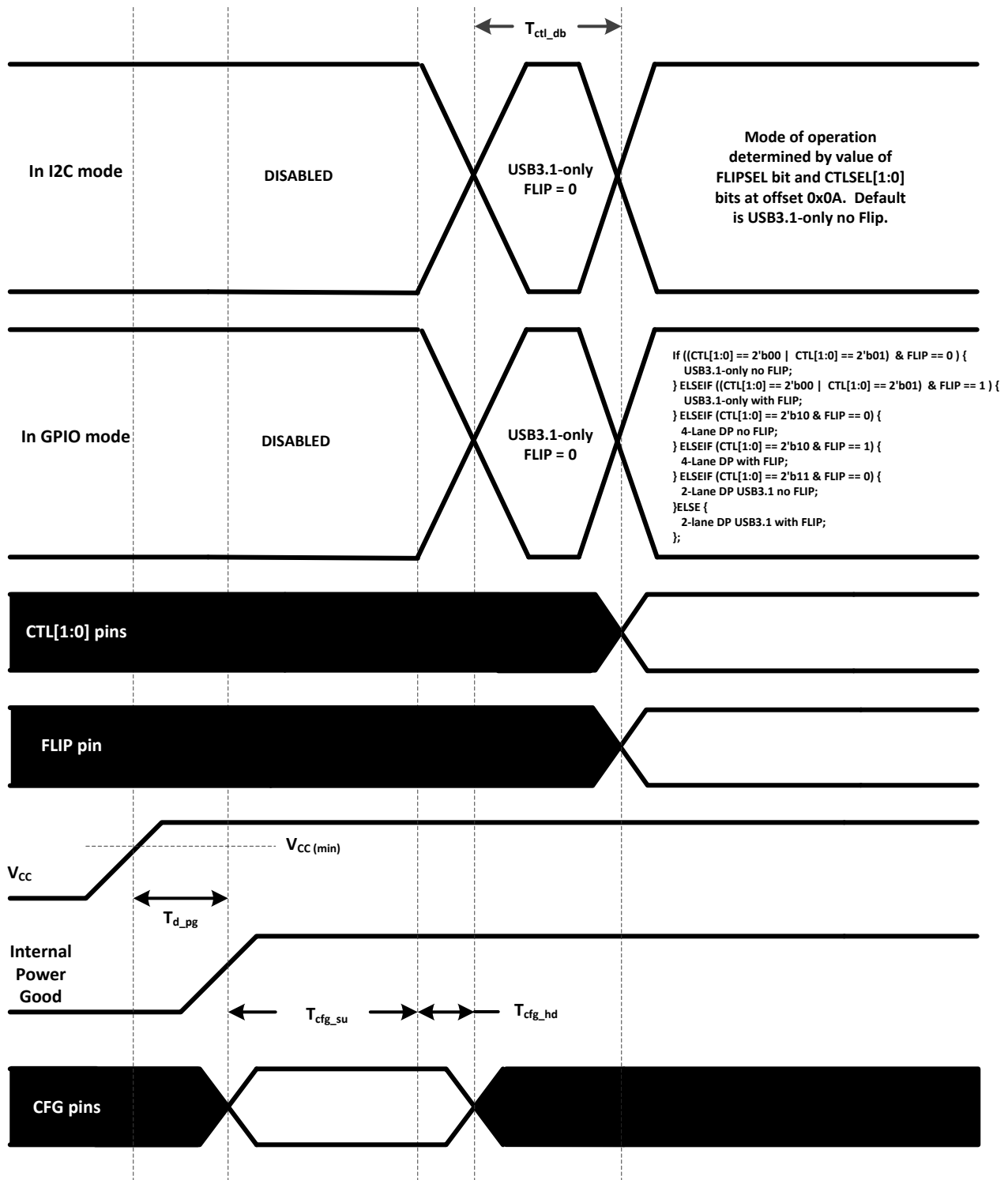
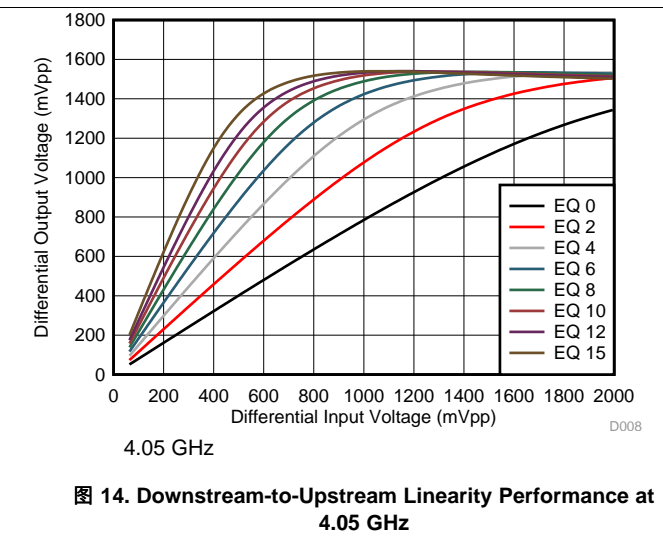
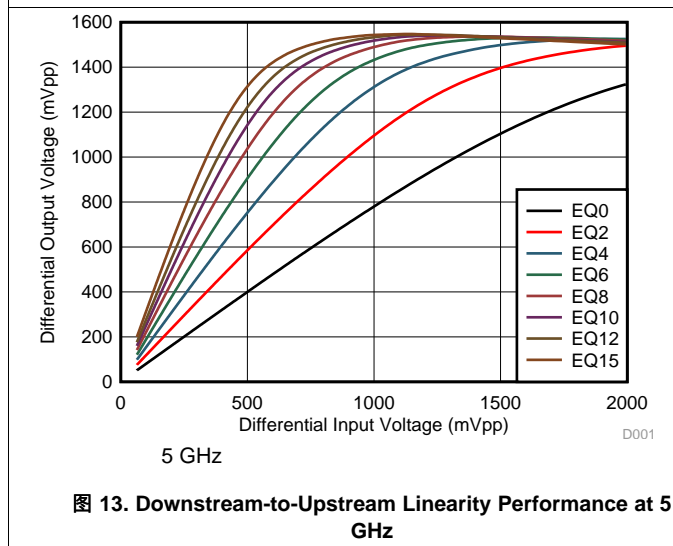
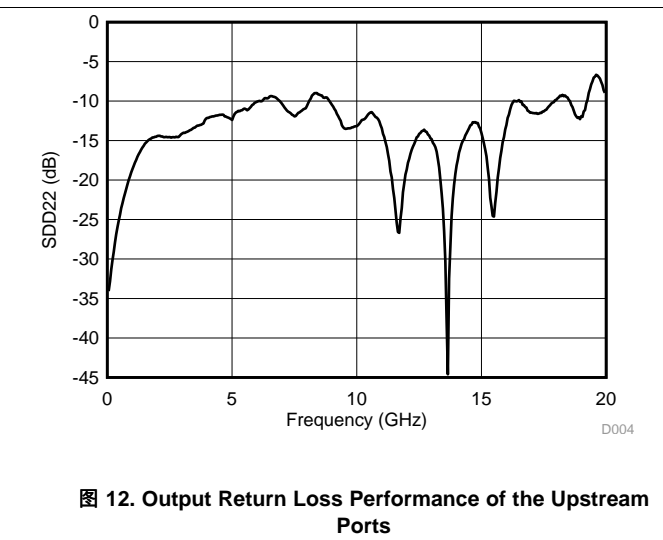
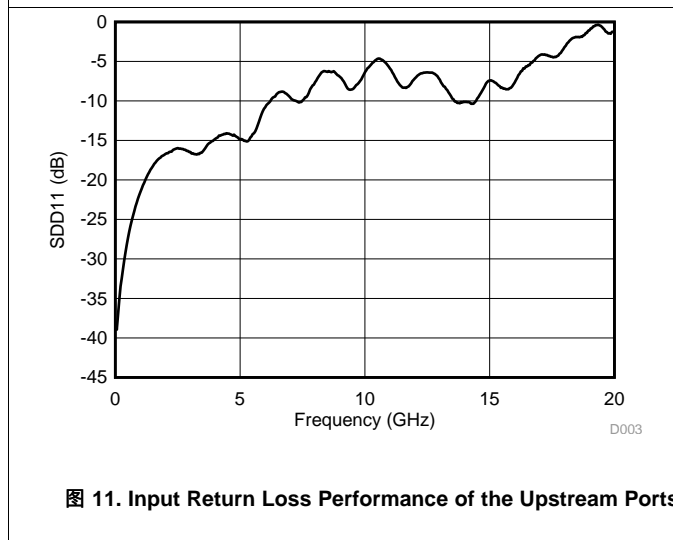
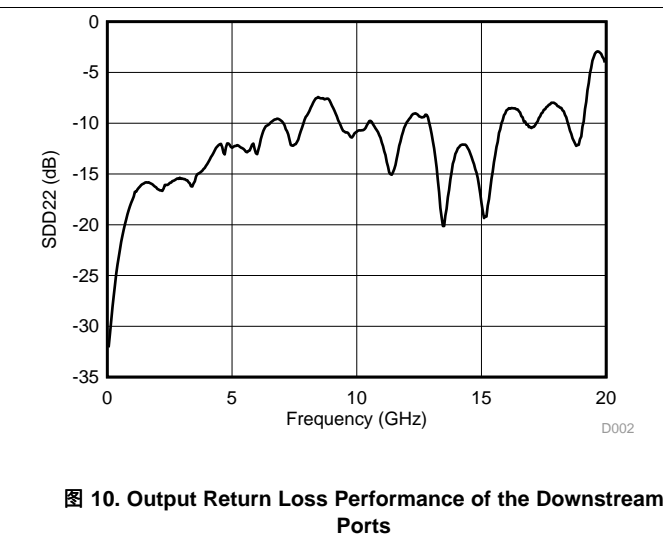
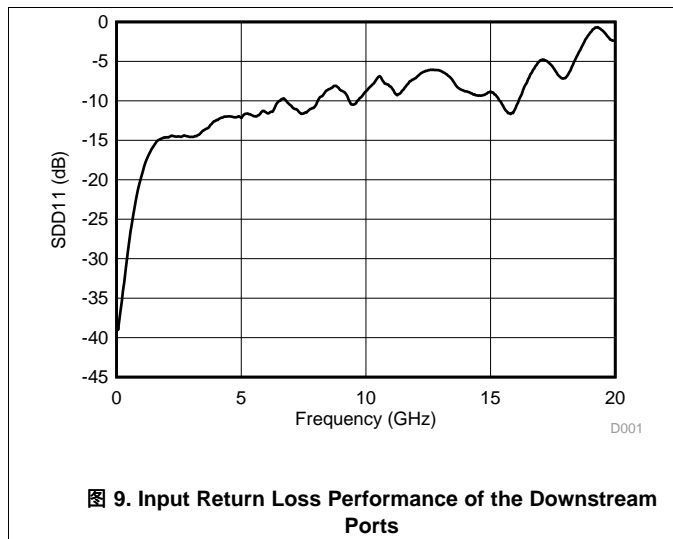

图 15. Downstream-to-Upstream Linearity Performance at 100 MHz



图 16. Upstream-to-Downstream Linearity Performance at 5 GHz

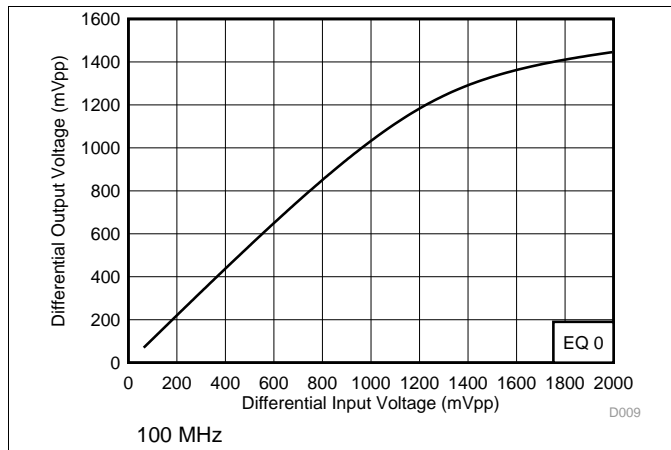

图 17. Upstream-to-Downstream Linearity Performance at 4.05 GHz

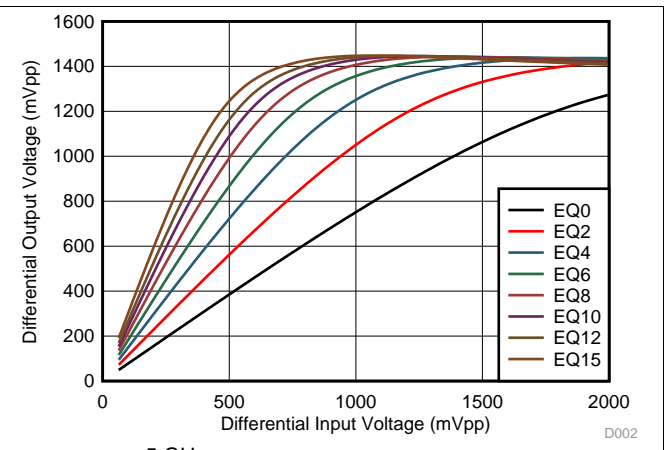

图 18. Upstream-to-Downstream Linearity Performance at 100 MHz

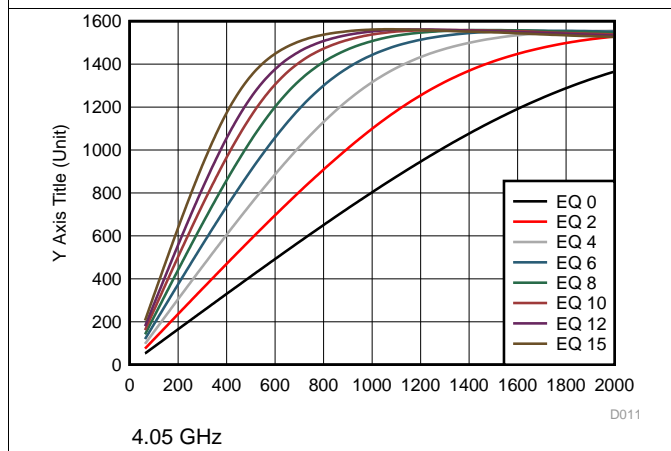

Source: Data Rate: 10 Gbps; Data Pattern: PRBS7; Swing: 1 Vpp
 Channel: Upstream-to-Downstream, 12 in 6 mil Input PCB Channel
 Settings: EQ Setting: TBD; DC Gain Setting: 0 dB; Linear Range Setting: 1100 mVpp

图 19. Output Eye-Pattern Performance at 10 Gbps

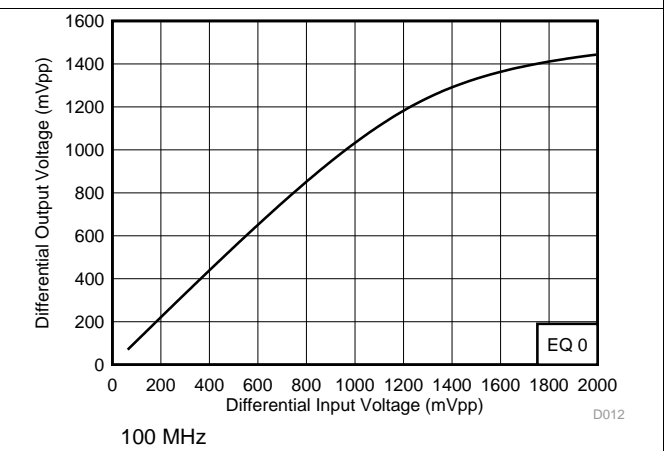
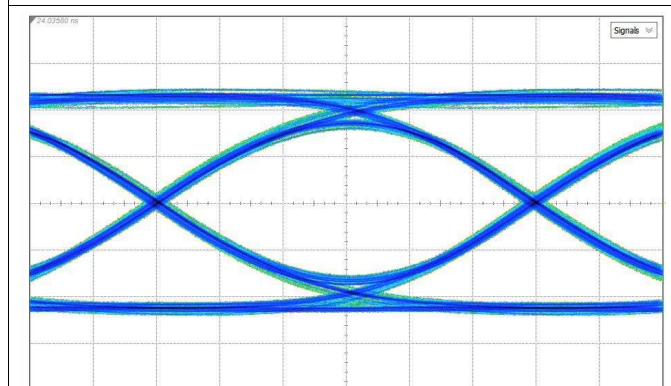
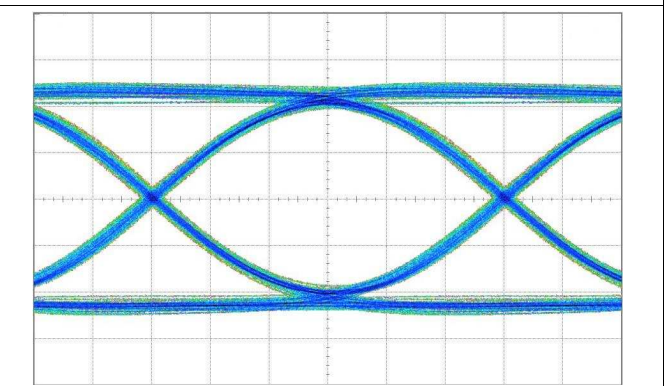

Source: Data Rate: 8.1 Gbps; Data Pattern: PRBS7; Swing: 1 Vpp
 Channel: Upstream-to-Downstream, 12 in 6 mil Input PCB Channel
 Settings: EQ Setting: 7; DC Gain Setting: 0 dB; Linear Range Setting: 1100 mVpp

图 20. Output Eye-Pattern Performance at 8.1 Gbps

Typical Characteristics (接下页)



图 21. Upstream-to-Downstream EQ Settings Curves



图 22. Downstream-to-Upstream EQ Settings Curves

7 Detailed Description

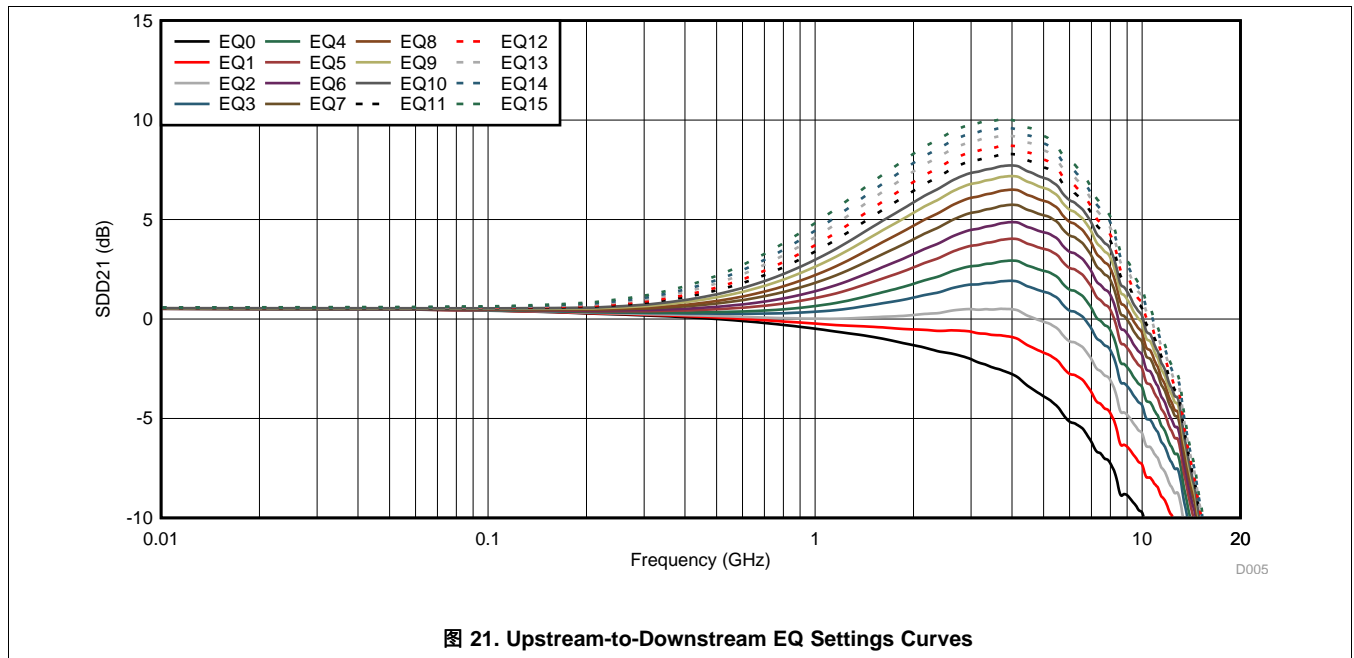
7.1 Overview

The TUSB1044 is a USB Type-C Alt Mode redriver switch supporting data rates up to 8.1 Gbps. This device implements 5th generation USB redriver technology. The device is used for configurations C, D, E, and F from the VESA DisplayPort Alt Mode on USB Type-C Standard. It can also be configured to support custom USB Type-C alternate modes.

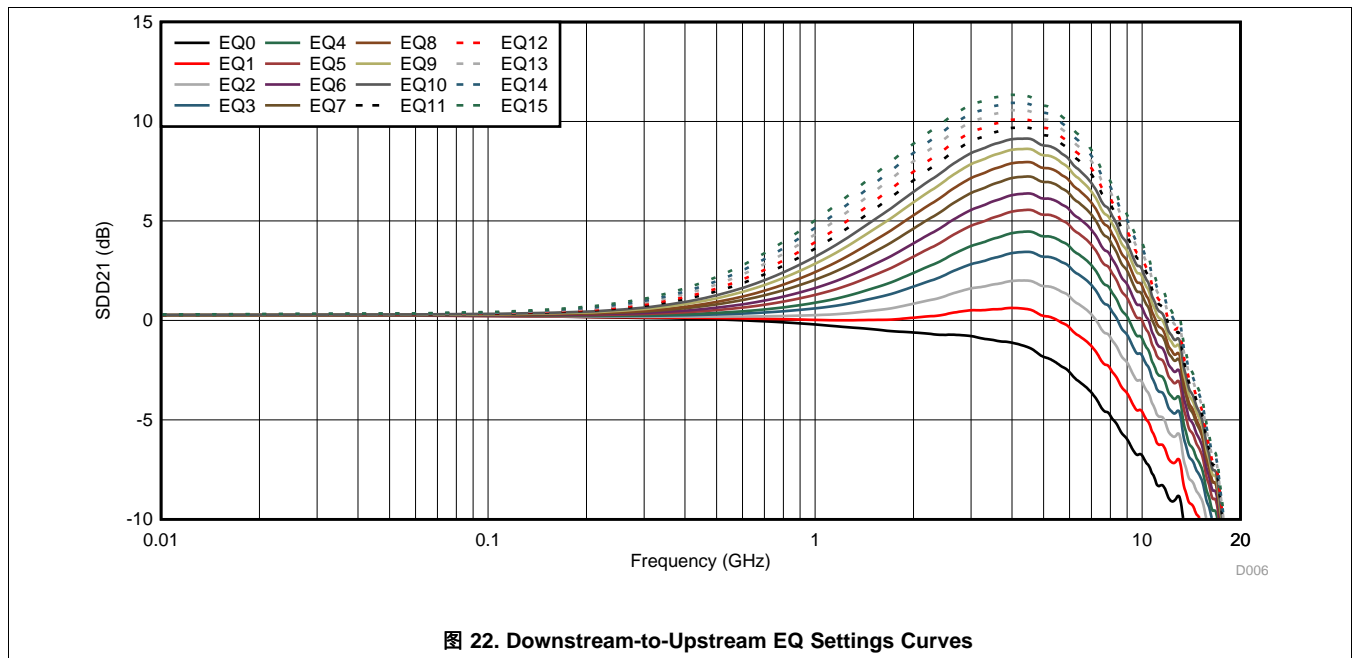
The TUSB1044 provides several levels of receive equalization to compensate for cable and board trace loss due to inter-symbol interference (ISI) when USB 3.1 Gen 2 or DisplayPort (or other Alt modes) signals travel across a PCB or cable. This device requires a 3.3V power supply. It comes for both commercial temperature range and industrial temperature range operation.

For host (source) or device (sink) applications, the TUSB1044 enables the system to pass both transmitter compliance and receiver jitter tolerance tests for USB 3.1 Gen 2 and DisplayPort version 1.4 HBR3. The re-driver recovers incoming data by applying equalization that compensates for channel loss, and drives out signals with a high differential voltage. Each channel has a receiver equalizer with selectable gain settings. Equalization control for upstream and downstream facing ports can be set using UEQ[1:0], and DEQ[1:0] pins respectively or through the I²C interface.

Moreover, the CFG[1:0] or the equivalent I²C registers provide the ability to control the EQ DC gain and the voltage linearity range for all the channels (Refer to [表 8](#)). This flexible control makes it easy to set up the device to pass various standard compliance requirements.

The TUSB1044 advanced state machine makes it transparent to hosts and devices. After power up, the TUSB1044 periodically performs receiver detection on the TX pairs. If it detects a USB 3.1 receiver, the RX termination is enabled, and the TUSB1044 is ready to re-drive.

The TUSB1044 provides extremely flexible data path signal direction control using the CTL[1:0], FLIP, DIR[1:0], and SWAP pins or through the I²C interface. Refer to [表 4](#) for detailed information on the input to output signal pin mapping.

The device ultra-low-power architecture operates at a 3.3 V power supply and achieves enhanced performance. The automatic LFPS De-Emphasis control further enables the system to be USB 3.1 compliant.

7.2 Functional Block Diagram

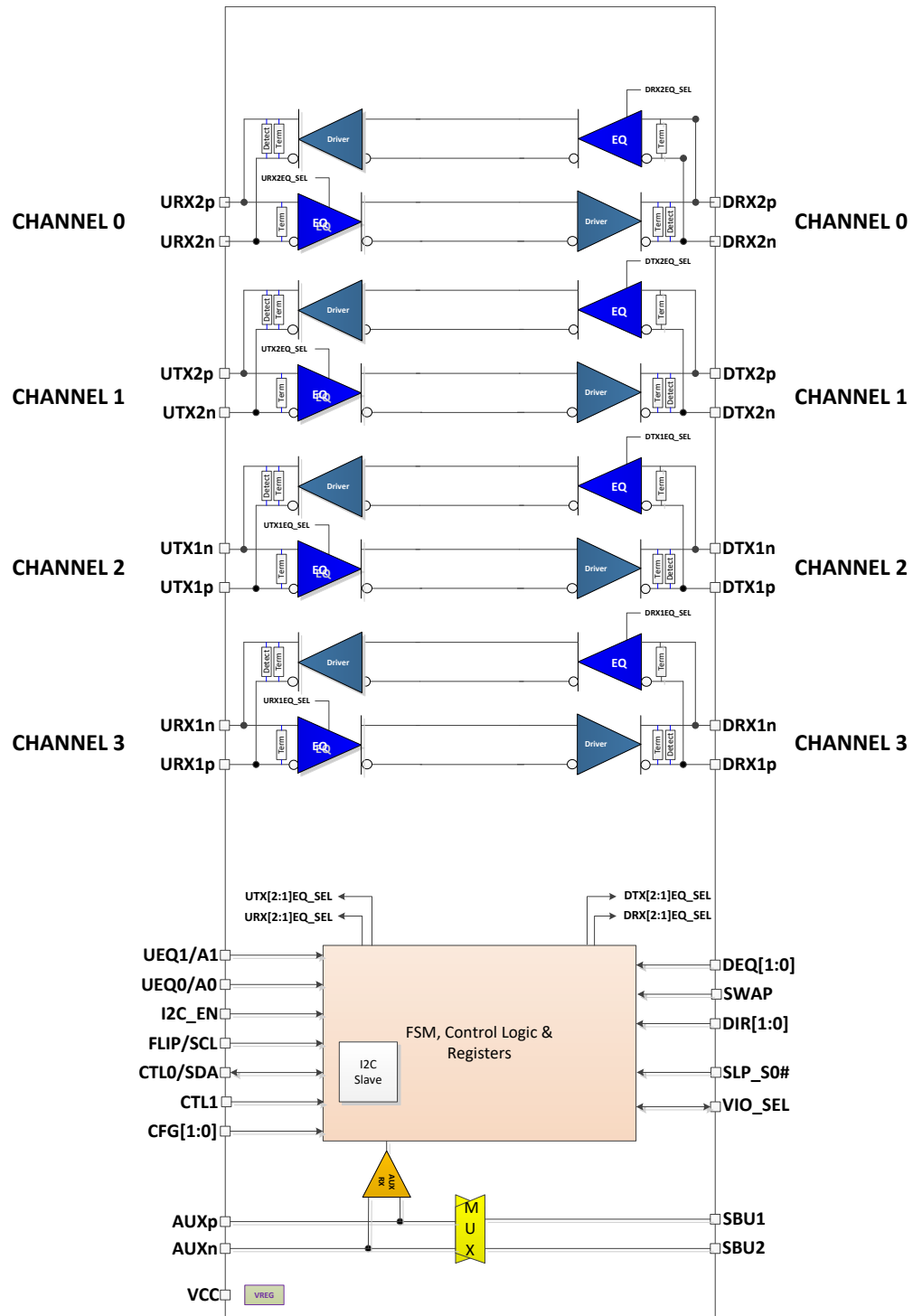

7.3 Feature Description

7.3.1 USB 3.1

The TUSB1044 supports USB 3.1 data rates up to 10 Gbps. The TUSB1044 supports all the USB defined power states (U0, U1, U2, and U3). Because the TUSB1044 is a linear redriver, it can't decode USB3.1 physical layer traffic. The TUSB1044 monitors the actual physical layer conditions like receiver termination, electrical idle, LFPS, and SuperSpeed signaling rate to determine the USB power state of the USB3.1 interface.

The TUSB1044 features an intelligent low frequency periodic signaling (LFPS) detector. The LFPS detector automatically senses the low frequency signals and disables receiver equalization functionality. When not receiving LFPS, the TUSB1044 enables receiver equalization based on the UEQ[1:0] and DEQ[1:0] pins or values programmed into UEQ[3:0]_SEL, and DEQ[3:0]_SEL registers.

7.3.2 DisplayPort

The TUSB1044 supports up to 4 DisplayPort lanes at data rates up to 8.1 Gbps (HBR3). The TUSB1044, when configured in DisplayPort mode, monitors the native AUX traffic as it traverses between DisplayPort source and DisplayPort sink. For the purposes of reducing power, the TUSB1044 manages the number of active DisplayPort lanes based on the content of the AUX transactions. The TUSB1044 snoops native AUX writes to DisplayPort sink's DPCD registers 00101h (LANE_COUNT_SET) and 00600h (SET_POWER_STATE). TUSB1044 disable or enable lanes based on value written to LANE_COUNT_SET. The TUSB1044 disables all lanes when SET_POWER_STATE is in the D3. Otherwise, active lanes are based on value of LANE_COUNT_SET.

DisplayPort AUX snooping is enabled by default but can be disabled by changing the AUX_SNOOP_DISABLE register. Once AUX snoop is disabled, management of TUSB1044 DisplayPort lanes are controlled through various configuration registers.

7.3.3 4-level Inputs

The TUSB1044 has (I2C_EN, UEQ[1:0], DEQ[1:0], CFG[1:0], and A[1:0]) 4-level inputs pins that are used to control the equalization gain, voltage linearity range, and place TUSB1044 into different modes of operation. These 4-level inputs utilize a resistor divider to help set the 4 valid levels and provide a wider range of control settings. There is an internal pull-up and a pull-down resistors. These resistors, together with the external resistor connection combine to achieve the desired voltage level.

表 1. 4-Level Control Pin Settings

LEVEL	SETTINGS
0	Option 1: Tie 1 K Ω 5% to GND. Option 2: Tie directly to GND.
R	Tie 20 K Ω 5% to GND.
F	Float (leave pin open)
1	Option 1: Tie 1 K Ω 5% to V _{CC} . Option 2: Tie directly to V _{CC} .

注

All four-level inputs are latched on rising edge of internal reset. After $T_{\text{cfg_hd}}$, the internal pull-up and pull-down resistors will be isolated in order to save power.

7.3.4 Receiver Linear Equalization

The purpose of receiver equalization is to compensate for channel insertion loss and inter-symbol interference in the system. The receiver overcomes these losses by attenuating the low frequency components of the signals with respect to the high frequency components. The proper gain setting should be selected to match the channel insertion loss. Two 4-level input pins enable up to 16 possible equalization settings. The upstream path, and the downstream path each have their own two 4-level inputs for equalization settings; UEQ[1:0] and DEQ[1:0] respectively. The TUSB1044 also provides the flexibility of adjusting equalization settings through I2C registers URX[2:1]EQ_SEL, UTX[2:1]EQ_SEL, DRX[2:1]EQ_SEL, and DTX[2:1]EQ_SEL for each individual channel and for each direction (upstream or downstream) .

7.4 Device Functional Modes

7.4.1 Device Configuration in GPIO mode

The TUSB1044 is in GPIO configuration when I2C_EN = "0" or I2C_EN = "F". The TUSB1044 supports operational combinations with USB and two different Type-C Alternate Modes. One combination includes USB and Alternate Mode DisplayPort, and the other combination includes USB and custom Alternate Mode. For each operational combination the data path directions can be further set using the DIR[1:0] pins or through I2C to enable the device to operate in the source or sink sides. Please refer to 表 2 for all the configuration of all the operational modes.

When the device is set to operate in a USB and Alternate Mode DisplayPort the following configurations can be further set: USB3.1 only, 2 DisplayPort lanes + USB3.1, or 4 DisplayPort lanes (no USB3.1). The CTL1 pin controls whether DisplayPort mode is enabled. The combination of CTL1 and CTL0 selects between USB3.1 only, 2 lanes of DisplayPort, or 4-lanes of DisplayPort as detailed in 表 2. The AUXP/N to SBU1/2 mapping is controlled based on 表 3..

When the device is set to operate in a USB and custom Alternate Mode, the following configurations can be further set: USB3.1 only, 2 Channels of custom Alternate Mode + USB3.1, or 4 Channels of custom Alternate Mode (no USB3.1). The CTL1 pin controls whether custom Alternate Mode is enabled. The combination of CTL1 and CTL0 selects between USB3.1 only, 2 channels of custom Alternate Mode, or 4 channels of custom Alternate Mode as detailed in 表 2. The AUXP/N to SBU1/2 mapping is controlled based on 表 3.

Further data path direction control can be achieved using the SWAP pin. When set high, the SWAP pin reverses the data path direction on all the channels and swaps the equalization settings of the upstream and downstream facing input ports. This pin may be found useful in active cable application with TUSB1044 installed on only one end. The SWAP pin can be set based on which cable end is plugged to the source or sink side receptacle

After power-up (VCC from 0 V to 3.3 V), the TUSB1044 will default to USB3.1 mode. The USB PD controller, upon detecting no device attached to Type-C port or USB3.1 operation not required by attached device, must take TUSB1044 out of USB3.1 mode by transitioning the CTL0 pin from L to H and back to L.

表 2. GPIO Configuration Control

DIR1 PIN	DIR0 PIN	CTL1 PIN	CTL0 PIN	FLIP PIN	TUSB1044 CONFIGURATION	VESA DisplayPort ALT MODE DFP_D Configuration
USB + DisplayPort Alternate Mode (Source Side)						
L	L	L	L	L	Power Down	—
L	L	L	L	H	Power Down	—
L	L	L	H	L	One Port USB 3.1 - No Flip	—
L	L	L	H	H	One Port USB 3.1 – With Flip	—
L	L	H	L	L	4 Lane DP - No Flip	C and E
L	L	H	L	H	4 Lane DP – with Flip	C and E
L	L	H	H	L	One Port USB 3.1 + 2 Lane DP- No Flip	D and F
L	L	H	H	H	One Port USB 3.1 + 2 Lane DP– with Flip	D and F
USB + DisplayPort Alternate Mode (Sink Side)						
L	H	L	L	L	Power Down	–
L	H	L	L	H	Power Down	–
L	H	L	H	L	One Port USB 3.1 - No Flip	–
L	H	L	H	H	One Port USB 3.1 – With Flip	–
L	H	H	L	L	4 Lane DP - No Flip	C and E
L	H	H	L	H	4 Lane DP – With Flip	C and E
L	H	H	H	L	One Port USB 3.1 + 2 Lane DP- No Flip	D and F
L	H	H	H	H	One Port USB 3.1 + 2 Lane DP– With Flip	D and F

Device Functional Modes (接下页)
表 2. GPIO Configuration Control (接下页)

DIR1 PIN	DIR0 PIN	CTL1 PIN	CTL0 PIN	FLIP PIN	TUSB1044 CONFIGURATION	VESA DisplayPort ALT MODE DFP_D Configuration
USB + Custom Alternate Mode (Source Side)						
H	L	L	L	L	Power Down	–
H	L	L	L	H	Power Down	–
H	L	L	H	L	One Port USB 3.1 - No Flip	–
H	L	L	H	H	One Port USB 3.1 – With Flip	–
H	L	H	L	L	4 Channel Custom Alt Mode - No Flip	–
H	L	H	L	H	4 Channel Custom Alt Mode– With Flip	–
H	L	H	H	L	One Port USB 3.1 + 2 Channel Custom Alt Mode- No Flip	–
H	L	H	H	H	One Port USB 3.1 + 2 Channel Custom Alt Mode – With Flip	–
USB + Custom Alternate Mode (Sink Side)						
H	H	L	L	L	Power Down	-
H	H	L	L	H	Power Down	-
H	H	L	H	L	One Port USB 3.1 - No Flip	-
H	H	L	H	H	One Port USB 3.1 – With Flip	-
H	H	H	L	L	4 Channel Custom Alt Mode - No Flip	-
H	H	H	L	H	4 Channel Custom Alt Mode– With Flip	-
H	H	H	H	L	One Port USB 3.1 + 2 Channel Custom Alt Mode- No Flip	-
H	H	H	H	H	One Port USB 3.1 + 2 Channel Custom Alt Mode – With Flip	-

表 3. GPIO AUXP/N to SBU1/2 Mapping

CTL1 pin	FLIP pin	Mapping
H	L	AUXP -> SBU1 AUXN -> SBU2
H	H	AUXP -> SBU2 AUXN -> SBU1
L > 2ms	X	Open

表 4 details the TUSB1044 mux routing. This table is valid for GPIO Mode. This table is also valid for I2C mode if CH_SWAP_SEL = 4'b0000 or 4'b1111.

表 4. INPUT to OUTPUT Mapping

					SWAP = L			SWAP = H		
					From	From	To	From	From	To
DIR1 PIN	DIR0 PIN	CTL1 PIN	CTL0 PIN	FLIP PIN	Rx EQ Control PINS	Input PIN	Output PIN	Rx EQ Control PINS	Input PIN	Output PIN
USB + DisplayPort Alternate Mode (Source Side)										
L	L	L	L	L	NA	NA	NA	NA	NA	NA
L	L	L	L	H	NA	NA	NA	NA	NA	NA
L	L	L	H	L	DEQ[1:0]	DRX1P	URX1P (SSRXP)	DEQ[1:0]	URX1P (SSTXP)	DRX1P
					DEQ[1:0]	DRX1N	URX1N (SSRXN)	DEQ[1:0]	URX1N (SSTXN)	DRX1N
					UEQ[1:0]	UTX1P (SSTXP)	DTX1P	UEQ[1:0]	DTX1P	UTX1P (SSRXP)
					UEQ[1:0]	UTX1N (SSTXN)	DTX1N	UEQ[1:0]	DTX1N	UTX1N (SSRXN)
L	L	L	H	H	DEQ[1:0]	DRX2P	URX2P (SSRXP)	DEQ[1:0]	URX2P (SSTXP)	DRX2P
					DEQ[1:0]	DRX2N	URX2N (SSRXN)	DEQ[1:0]	URX2N (SSTXN)	DRX2N
					UEQ[1:0]	UTX2P (SSTXP)	DTX2P	UEQ[1:0]	DTX2P	UTX2P (SSRXP)
					UEQ[1:0]	UTX2N (SSTXN)	DTX2N	UEQ[1:0]	DTX2N	UTX2N (SSRXN)
L	L	H	L	L	UEQ[1:0]	URX2P (DP0P)	DRX2P	UEQ[1:0]	DRX2P	URX2P (DP0P)
					UEQ[1:0]	URX2N (DP0N)	DRX2N	UEQ[1:0]	DRX2N	URX2N (DP0N)
					UEQ[1:0]	UTX2P (DP1P)	DTX2P	UEQ[1:0]	DTX2P	UTX2P (DP1P)
					UEQ[1:0]	UTX2N (DP1N)	DTX2N	UEQ[1:0]	DTX2N	UTX2N (DP1N)
					UEQ[1:0]	UTX1P (DP2P)	DTX1P	UEQ[1:0]	DTX1P	UTX1P (DP2P)
					UEQ[1:0]	UTX1N (DP2N)	DTX1N	UEQ[1:0]	DTX1N	UTX1N (DP2N)
					UEQ[1:0]	URX1P (DP3P)	DRX1P	UEQ[1:0]	DRX1P	URX1P (DP3P)
					UEQ[1:0]	URX1N (DP3N)	DRX1N	UEQ[1:0]	DRX1N	URX1N (DP3N)

表 4. INPUT to OUTPUT Mapping (接下页)

					SWAP = L			SWAP = H		
					From	From	To	From	From	To
DIR1 PIN	DIR0 PIN	CTL1 PIN	CTL0 PIN	FLIP PIN	Rx EQ Control PINS	Input PIN	Output PIN	Rx EQ Control PINS	Input PIN	Output PIN
L	L	H	L	H	UEQ[1:0]	URX1P (DP0P)	DRX1P	UEQ[1:0]	DRX1P	URX1P (DP0P)
					UEQ[1:0]	URX1N (DP0N)	DRX1N	UEQ[1:0]	DRX1N	URX1N (DP0N)
					UEQ[1:0]	UTX1P (DP1P)	DTX1P	UEQ[1:0]	DTX1P	UTX1P (DP1P)
					UEQ[1:0]	UTX1N (DP1N)	DTX1N	UEQ[1:0]	DTX1N	UTX1N (DP1N)
					UEQ[1:0]	UTX2P (DP2P)	DTX2P	UEQ[1:0]	DTX2P	UTX2P (DP2P)
					UEQ[1:0]	UTX2N (DP2N)	DTX2N	UEQ[1:0]	DTX2N	UTX2N (DP2N)
					UEQ[1:0]	URX2P (DP3P)	DRX2P	UEQ[1:0]	DRX2P	URX2P (DP3P)
					UEQ[1:0]	URX2N (DP3N)	DRX2N	UEQ[1:0]	DRX2N	URX2N (DP3N)
L	L	H	H	L	DEQ[1:0]	DRX1P	URX1P (SSRXP)	DEQ[1:0]	URX1P (SSTXP)	DRX1P
					DEQ[1:0]	DRX1N	URX1N (SSRXN)	DEQ[1:0]	URX1N (SSTXN)	DRX1N
					UEQ[1:0]	UTX1P (SSTXP)	DTX1P	UEQ[1:0]	DTX1P	UTX1P (SSRXP)
					UEQ[1:0]	UTX1N (SSTXN)	DTX1N	UEQ[1:0]	DTX1N	UTX1N (SSRXN)
					UEQ[1:0]	URX2P (DP0P)	DRX2P	UEQ[1:0]	DRX2P	URX2P (DP0P)
					UEQ[1:0]	URX2N (DP0N)	DRX2N	UEQ[1:0]	DRX2N	URX2N (DP0N)
					UEQ[1:0]	UTX2P (DP1P)	DTX2P	UEQ[1:0]	DTX2P	UTX2P (DP1P)
					UEQ[1:0]	UTX2N (DP1N)	DTX2N	UEQ[1:0]	DTX2N	UTX2N (DP1N)
L	L	H	H	H	DEQ[1:0]	DRX2P	URX2P (SSRXP)	DEQ[1:0]	URX2P (SSTXP)	DRX2P
					DEQ[1:0]	DRX2N	URX2N (SSRXN)	DEQ[1:0]	URX2N (SSTXN)	DRX2N
					UEQ[1:0]	UTX2P (SSTXP)	DTX2P	UEQ[1:0]	DTX2P	UTX2P (SSRXP)
					UEQ[1:0]	UTX2N (SSTXN)	DTX2N	UEQ[1:0]	DTX2N	UTX2N (SSRXN)
					UEQ[1:0]	URX1P (DP0P)	DRX1P	UEQ[1:0]	DRX1P	URX1P (DP0P)
					UEQ[1:0]	URX1N (DP0N)	DRX1N	UEQ[1:0]	DRX1N	URX1N (DP0N)
					UEQ[1:0]	UTX1P (DP1P)	DTX1P	UEQ[1:0]	DTX1P	UTX1P (DP1P)
					UEQ[1:0]	UTX1N (DP1N)	DTX1N	UEQ[1:0]	DTX1N	UTX1N (DP1N)
USB + DisplayPort Alternate Mode (Sink Side)										
L	H	L	L	L	NA	NA	NA	NA	NA	NA
L	H	L	L	H	NA	NA	NA	NA	NA	NA

表 4. INPUT to OUTPUT Mapping (接下页)

					SWAP = L			SWAP = H		
					From	From	To	From	From	To
DIR1 PIN	DIR0 PIN	CTL1 PIN	CTL0 PIN	FLIP PIN	Rx EQ Control PINS	Input PIN	Output PIN	Rx EQ Control PINS	Input PIN	Output PIN
L	H	L	H	L	UEQ[1:0]	UTX2P	DTX2P (SSRXP)	UEQ[1:0]	DTX2P (SSTXP)	UTX2P
					UEQ[1:0]	UTX2N	DTX2N (SSRXN)	UEQ[1:0]	DTX2N (SSTXN)	UTX2N
					DEQ[1:0]	DRX2P (SSTXP)	URX2P	DEQ[1:0]	URX2P	DRX2P (SSRXP)
					DEQ[1:0]	DRX2N (SSTXN)	URX2N	DEQ[1:0]	URX2N	DRX2N (SSRXN)
L	H	L	H	H	UEQ[1:0]	UTX1P	DTX1P (SSRXP)	UEQ[1:0]	DTX1P (SSTXP)	UTX1P
					UEQ[1:0]	UTX1N	DTX1N (SSRXN)	UEQ[1:0]	DTX1N (SSTXN)	UTX1N
					DEQ[1:0]	DRX1P (SSTXP)	URX1P	DEQ[1:0]	URX1P	DRX1P (SSRXP)
					DEQ[1:0]	DRX1N (SSTXN)	URX1N	DEQ[1:0]	URX1N	DRX1N (SSRXN)
L	H	H	L	L	UEQ[1:0]	URX2P	DRX2P (DP3P)	UEQ[1:0]	DRX2P (DP3P)	URX2P
					UEQ[1:0]	URX2N	DRX2N (DP3N)	UEQ[1:0]	DRX2N (DP3N)	URX2N
					UEQ[1:0]	UTX2P	DTX2P (DP2P)	UEQ[1:0]	DTX2P (DP2P)	UTX2P
					UEQ[1:0]	UTX2N	DTX2N (DP2N)	UEQ[1:0]	DTX2N (DP2N)	UTX2N
					UEQ[1:0]	UTX1P	DTX1P (DP1P)	UEQ[1:0]	DTX1P (DP1P)	UTX1P
					UEQ[1:0]	UTX1N	DTX1N (DP1N)	UEQ[1:0]	DTX1N (DP1N)	UTX1N
					UEQ[1:0]	URX1P	DRX1P (DP0P)	UEQ[1:0]	DRX1P (DP0P)	URX1P
					UEQ[1:0]	URX1N	DRX1N (DP0N)	UEQ[1:0]	DRX1N (DP0N)	URX1N
L	H	H	L	H	UEQ[1:0]	URX1P	DRX1P (DP3P)	UEQ[1:0]	DRX1P (DP3P)	URX1P
					UEQ[1:0]	URX1N	DRX1N (DP3N)	UEQ[1:0]	DRX1N (DP3N)	URX1N
					UEQ[1:0]	UTX1P	DTX1P (DP2P)	UEQ[1:0]	DTX1P (DP2P)	UTX1P
					UEQ[1:0]	UTX1N	DTX1N (DP2N)	UEQ[1:0]	DTX1N (DP2N)	UTX1N
					UEQ[1:0]	UTX2P	DTX2P (DP1P)	UEQ[1:0]	DTX2P (DP1P)	UTX2P
					UEQ[1:0]	UTX2N	DTX2N (DP1N)	UEQ[1:0]	DTX2N (DP1N)	UTX2N
					UEQ[1:0]	URX2P	DRX2P (DP0P)	UEQ[1:0]	DRX2P (DP0P)	URX2P
					UEQ[1:0]	URX2N	DRX2N (DP0N)	UEQ[1:0]	DRX2N (DP0N)	URX2N

表 4. INPUT to OUTPUT Mapping (接下页)

					SWAP = L			SWAP = H		
					From	From	To	From	From	To
DIR1 PIN	DIR0 PIN	CTL1 PIN	CTL0 PIN	FLIP PIN	Rx EQ Control PINS	Input PIN	Output PIN	Rx EQ Control PINS	Input PIN	Output PIN
L	H	H	H	L	DEQ[1:0]	DRX2P (SSRXP)	URX2P	DEQ[1:0]	URX2P	DRX2P (SSRXP)
					DEQ[1:0]	DRX2N (SSRXN)	URX2N	DEQ[1:0]	URX2N	DRX2N (SSRXN)
					UEQ[1:0]	UTX2P	DTX2P (SSTXP)	UEQ[1:0]	DTX2P (SSTXP)	UTX2P
					UEQ[1:0]	UTX2N	DTX2N (SSTXN)	UEQ[1:0]	DTX2N (SSTXN)	UTX2N
					UEQ[1:0]	URX1P	DRX1P (DP0P)	UEQ[1:0]	DRX1P (DP0P)	URX1P
					UEQ[1:0]	URX1N	DRX1N (DP0N)	UEQ[1:0]	DRX1N (DP0N)	URX1N
					UEQ[1:0]	UTX1P	DTX1P (DP1P)	UEQ[1:0]	DTX1P (DP1P)	UTX1P
					UEQ[1:0]	UTX1N	DTX1N (DP1N)	UEQ[1:0]	DTX1N (DP1N)	UTX1N
L	H	H	H	H	DEQ[1:0]	DRX1P (SSRXP)	URX1P	DEQ[1:0]	URX1P	DRX1P (SSRXP)
					DEQ[1:0]	DRX1N (SSRXN)	URX1N	DEQ[1:0]	URX1N	DRX1N (SSRXN)
					UEQ[1:0]	UTX1P	DTX1P (SSTXP)	UEQ[1:0]	DTX1P (SSTXP)	UTX1P
					UEQ[1:0]	UTX1N	DTX1N (SSTXN)	UEQ[1:0]	DTX1N (SSTXN)	UTX1N
					UEQ[1:0]	URX2P	DRX2P (DP0P)	UEQ[1:0]	DRX2P (DP0P)	URX2P
					UEQ[1:0]	URX2N	DRX2N (DP0N)	UEQ[1:0]	DRX2N (DP0N)	URX2N
					UEQ[1:0]	UTX2P	DTX2P (DP1P)	UEQ[1:0]	DTX2P (DP1P)	UTX2P
					UEQ[1:0]	UTX2N	DTX2N (DP1N)	UEQ[1:0]	DTX2N (DP1N)	UTX2N
USB + Custom Alternate Mode (Source Side)										
H	L	L	L	L	NA	NA	NA	NA	NA	NA
H	L	L	L	H	NA	NA	NA	NA	NA	NA
H	L	L	H	L	DEQ[1:0]	DRX1P	URX1P (SSRXP)	DEQ[1:0]	URX1P (SSTXP)	DRX1P
					DEQ[1:0]	DRX1N	URX1N (SSRXN)	DEQ[1:0]	URX1N (SSTXN)	DRX1N
					UEQ[1:0]	UTX1P (SSTXP)	DTX1P	UEQ[1:0]	DTX1P	UTX1P (SSRXP)
					UEQ[1:0]	UTX1N (SSTXN)	DTX1N	UEQ[1:0]	DTX1N	UTX1N (SSRXN)
H	L	L	H	H	DEQ[1:0]	DRX2P	URX2P (SSRXP)	DEQ[1:0]	URX2P (SSTXP)	DRX2P
					DEQ[1:0]	DRX2N	URX2N (SSRXN)	DEQ[1:0]	URX2N (SSTXN)	DRX2N
					UEQ[1:0]	UTX2P (SSTXP)	DTX2P	UEQ[1:0]	DTX2P	UTX2P (SSRXP)
					UEQ[1:0]	UTX2N (SSTXN)	DTX2N	UEQ[1:0]	DTX2N	UTX2N (SSRXN)

表 4. INPUT to OUTPUT Mapping (接下页)

					SWAP = L			SWAP = H		
					From	From	To	From	From	To
DIR1 PIN	DIR0 PIN	CTL1 PIN	CTL0 PIN	FLIP PIN	Rx EQ Control PINS	Input PIN	Output PIN	Rx EQ Control PINS	Input PIN	Output PIN
H	L	H	L	L	DEQ[1:0]	DRX2P	URX2P (LN1RXP)	DEQ[1:0]	URX2P (LN1RXP)	DRX2P
					DEQ[1:0]	DRX2N	URX2N (LN1RXN)	DEQ[1:0]	URX2N (LN1RXN)	DRX2N
					UEQ[1:0]	UTX2P (LN1TXP)	DTX2P	UEQ[1:0]	DTX2P	UTX2P (LN1TXP)
					UEQ[1:0]	UTX2N (LN1TXN)	DTX2N	UEQ[1:0]	DTX2N	UTX2N (LN1TXN)
					UEQ[1:0]	UTX1P (LN0TXP)	DTX1P	UEQ[1:0]	DTX1P	UTX1P (LN0TXP)
					UEQ[1:0]	UTX1N (LN0TXN)	DTX1N	UEQ[1:0]	DTX1N	UTX1N (LN0TXN)
					DEQ[1:0]	DRX1P	URX1P (LN0RXP)	DEQ[1:0]	URX1P (LN0RXP)	DRX1P
					DEQ[1:0]	DRX1N	URX1N (LN0RXN)	DEQ[1:0]	URX1N (LN0RXN)	DRX1N
H	L	H	L	H	DEQ[1:0]	DRX1P	URX1P (LN1RXP)	DEQ[1:0]	URX1P (LN1RXP)	DRX1P
					DEQ[1:0]	DRX1N	URX1N (LN1RXN)	DEQ[1:0]	URX1N (LN1RXN)	DRX1N
					UEQ[1:0]	UTX1P (LN1TXP)	DTX1P	UEQ[1:0]	DTX1P	UTX1P (LN1TXP)
					UEQ[1:0]	UTX1N (LN1TXN)	DTX1N	UEQ[1:0]	DTX1N	UTX1N (LN1TXN)
					UEQ[1:0]	UTX2P (LN0TXP)	DTX2P	UEQ[1:0]	DTX2P	UTX2P (LN0TXP)
					UEQ[1:0]	UTX2N (LN0TXN)	DTX2N	UEQ[1:0]	DTX2N	UTX2N (LN0TXN)
H	L	H	H	L	DEQ[1:0]	DRX2P	URX2P (LN0RXP)	DEQ[1:0]	URX2P (LN0RXP)	DRX2P
					DEQ[1:0]	DRX2N	URX2N (LN0RXN)	DEQ[1:0]	URX2N (LN0RXN)	DRX2N
					DEQ[1:0]	DRX1P	URX1P (SSRXP)	DEQ[1:0]	URX1P (SSTXP)	DRX1P
					DEQ[1:0]	DRX1N	URX1N (SSRXN)	DEQ[1:0]	URX1N (SSTXN)	DRX1N
					UEQ[1:0]	UTX1P (SSTXP)	DTX1P	UEQ[1:0]	DTX1P	UTX1P (SSRXP)
					UEQ[1:0]	UTX1N (SSTXN)	DTX1N	UEQ[1:0]	DTX1N	UTX1N (SSRXN)
					UEQ[1:0]	UTX2P (LN0TXP)	DTX2P	UEQ[1:0]	DTX2P	UTX2P (LN0TXP)
					UEQ[1:0]	UTX2N (LN0TXN)	DTX2N	UEQ[1:0]	DTX2N	UTX2N (LN0TXN)
					DEQ[1:0]	DRX2P	URX2P (LN0RXP)	DEQ[1:0]	URX2P (LN0RXP)	DRX2P
					DEQ[1:0]	DRX2N	URX2N (LN0RXN)	DEQ[1:0]	URX2N (LN0RXN)	DRX2N

表 4. INPUT to OUTPUT Mapping (接下页)

					SWAP = L			SWAP = H		
					From	From	To	From	From	To
DIR1 PIN	DIR0 PIN	CTL1 PIN	CTL0 PIN	FLIP PIN	Rx EQ Control PINS	Input PIN	Output PIN	Rx EQ Control PINS	Input PIN	Output PIN
H	L	H	H	H	DEQ[1:0]	DRX2P	URX2P (SSRXP)	DEQ[1:0]	URX2P (SSTXP)	DRX2P
					DEQ[1:0]	DRX2N	URX2N (SSRXN)	DEQ[1:0]	URX2N (SSTXN)	DRX2N
					UEQ[1:0]	UTX2P (SSTXP)	DTX2P	UEQ[1:0]	DTX2P	UTX2P (SSRXP)
					UEQ[1:0]	UTX2N (SSTXN)	DTX2N	UEQ[1:0]	DTX2N	UTX2N (SSRXN)
					UEQ[1:0]	UTX1P (LN0TXP)	DTX1P	UEQ[1:0]	DTX1P	UTX1P (LN0TXP)
					UEQ[1:0]	UTX1N (LN0TXN)	DTX1N	UEQ[1:0]	DTX1N	UTX1N (LN0TXN)
					DEQ[1:0]	DRX1P	URX1P (LN0RXP)	DEQ[1:0]	URX1P (LN0RXP)	DRX1P
					DEQ[1:0]	DRX1N	URX1N (LN0RXN)	DEQ[1:0]	URX1N (LN0RXN)	DRX1N
USB + Custom Alternate Mode (Sink Side)										
H	H	L	L	L	NA	NA	NA	NA	NA	NA
H	H	L	L	H	NA	NA	NA	NA	NA	NA
H	H	L	H	L	UEQ[1:0]	UTX2P	DTX2P (SSRXP)	UEQ[1:0]	DTX2P (SSTXP)	UTX2P
					UEQ[1:0]	UTX2N	DTX2N (SSRXN)	UEQ[1:0]	DTX2N (SSTXN)	UTX2N
					DEQ[1:0]	DRX2P (SSTXP)	URX2P	DEQ[1:0]	URX2P	DRX2P (SSRXP)
					DEQ[1:0]	DRX2N (SSTXN)	URX2N	DEQ[1:0]	URX2N	DRX2N (SSRXN)
H	H	L	H	H	UEQ[1:0]	UTX1P	DTX1P (SSRXP)	UEQ[1:0]	DTX1P (SSTXP)	UTX1P
					UEQ[1:0]	UTX1N	DTX1N (SSRXN)	UEQ[1:0]	DTX1N (SSTXN)	UTX1N
					DEQ[1:0]	DRX1P (SSTXP)	URX1P	DEQ[1:0]	URX1P	DRX1P (SSRXP)
					DEQ[1:0]	DRX1N (SSTXN)	URX1N	DEQ[1:0]	URX1N	DRX1N (SSRXN)
H	H	H	L	L	DEQ[1:0]	DRX2P	URX2P (LN1TXP)	DEQ[1:0]	URX2P (LN1TXP)	DRX2P
					DEQ[1:0]	DRX2N	URX2N (LN1TXN)	DEQ[1:0]	URX2N (LN1TXN)	DRX2N
					UEQ[1:0]	UTX2P (LN1RXP)	DTX2P	UEQ[1:0]	DTX2P	UTX2P (LN1RXP)
					UEQ[1:0]	UTX2N (LN1RXN)	DTX2N	UEQ[1:0]	DTX2N	UTX2N (LN1RXN)
					UEQ[1:0]	UTX1P (LN0RXP)	DTX1P	UEQ[1:0]	DTX1P	UTX1P (LN0RXP)
					UEQ[1:0]	UTX1N (LN0RXN)	DTX1N	UEQ[1:0]	DTX1N	UTX1N (LN0RXN)
					DEQ[1:0]	DRX1P	URX1P (LN0RXP)	DEQ[1:0]	URX1P (LN0RXP)	DRX1P
					DEQ[1:0]	DRX1N	URX1N (LN0RXN)	DEQ[1:0]	URX1N (LN0RXN)	DRX1N

表 4. INPUT to OUTPUT Mapping (接下页)

					SWAP = L			SWAP = H		
					From	From	To	From	From	To
DIR1 PIN	DIR0 PIN	CTL1 PIN	CTL0 PIN	FLIP PIN	Rx EQ Control PINS	Input PIN	Output PIN	Rx EQ Control PINS	Input PIN	Output PIN
H	H	H	L	H	DEQ[1:0]	DRX2P	URX2P (LN0RXP)	DEQ[1:0]	URX2P (LN0RXP)	DRX2P
					DEQ[1:0]	DRX2N	URX2N (LN0RXN)	DEQ[1:0]	URX2N (LN0RXN)	DRX2N
					UEQ[1:0]	UTX2P (LN0RXP)	DTX2P	UEQ[1:0]	DTX2P	UTX2P (LN0RXP)
					UEQ[1:0]	UTX2N (LN0RXN)	DTX2N	UEQ[1:0]	DTX2N	UTX2N (LN0RXN)
					UEQ[1:0]	UTX1P (LN0RXP)	DTX1P	UEQ[1:0]	DTX1P	UTX1P (LN0RXP)
					UEQ[1:0]	UTX1N (LN0RXN)	DTX1N	UEQ[1:0]	DTX1N	UTX1N (LN0RXN)
					DEQ[1:0]	DRX1P	URX1P (LN0TXP)	DEQ[1:0]	URX1P (LN0TXP)	DRX1P
					DEQ[1:0]	DRX1N	URX1N (LN0TXN)	DEQ[1:0]	URX1N (LN0TXN)	DRX1N
H	H	H	H	L	UEQ[1:0]	UTX2P	DTX2P (SSRXP)	UEQ[1:0]	DTX2P (SSTXP)	UTX2P
					UEQ[1:0]	UTX2N	DTX2N (SSRXN)	UEQ[1:0]	DTX2N (SSTXN)	UTX2N
					DEQ[1:0]	DRX2P (SSTXP)	URX2P	DEQ[1:0]	URX2P	DRX2P (SSRXP)
					DEQ[1:0]	DRX2N (SSTXN)	URX2N	DEQ[1:0]	URX2N	DRX2N (SSRXN)
					UEQ[1:0]	UTX1P	DTX1P (LN0RXP)	UEQ[1:0]	DTX1P (LN0RXP)	UTX1P
					UEQ[1:0]	UTX1N	DTX1N(LN0R XN)	UEQ[1:0]	DTX1N(LN0R XN)	UTX1N
					DEQ[1:0]	DRX1P (LN0TXP)	URX1P	DEQ[1:0]	URX1P	DRX1P (LN0TXP)
					DEQ[1:0]	DRX1N (LN0TXN)	URX1N	DEQ[1:0]	URX1N	DRX1N (LN0TXN)
H	H	H	H	H	UEQ[1:0]	UTX1P	DTX1P (SSRXP)	UEQ[1:0]	DTX1P (SSSXP)	UTX1P
					UEQ[1:0]	UTX1N	DTX1N (SSRXN)	UEQ[1:0]	DTX1N (SSSXN)	UTX1N
					DEQ[1:0]	DRX1P (SSTXP)	URX1P	DEQ[1:0]	URX1P	DRX1P (SSRXP)
					DEQ[1:0]	DRX1N (SSTXN)	URX1N	DEQ[1:0]	URX1N	DRX1N (SSRXN)
					DEQ[1:0]	DRX2P	URX2P (LN0TXP)	DEQ[1:0]	URX2P (LN0TXP)	DRX2P
					DEQ[1:0]	DRX2N	URX2N (LN0TXN)	DEQ[1:0]	URX2N (LN0TXN)	DRX2N
					UEQ[1:0]	UTX2P (LN0RXP)	DTX2P	UEQ[1:0]	DTX2P	UTX2P (LN0RXP)
					UEQ[1:0]	UTX2N (LN0RXN)	DTX2N	UEQ[1:0]	DTX2N	UTX2N (LN0RXN)

7.4.2 Device Configuration in I2C Mode

The TUSB1044 is in I2C mode when I2C_EN is equal to “1”. The same configurations defined in GPIO mode are also available in I2C mode. The TUSB1044 USB3.1, DisplayPort, and custom Alternate Mode configuration is controlled based on 表 5. The AUXP/N to SBU1/2 mapping control is based on 表 5.

表 5. I2C Configuration Control

Registers					TUSB1044 Configuration	VESA DisplayPort Alt Mode DFP_D Configuration
DIRSEL1	DIRSEL0	CTLSEL1	CTLSEL0	FLIPSEL		
USB + DisplayPort Alternate Mode (Source Side)						
L	L	L	L	L	Power Down	–
L	L	L	L	H	Power Down	–
L	L	L	H	L	One Port USB 3.1 - No Flip	–
L	L	L	H	H	One Port USB 3.1 – With Flip	–
L	L	H	L	L	4 Lane DP - No Flip	C and E
L	L	H	L	H	4 Lane DP – With Flip	C and E
L	L	H	H	L	One Port USB 3.1 + 2 Lane DP- No Flip	D and F
L	L	H	H	H	One Port USB 3.1 + 2 Lane DP– With Flip	D and F
USB + DisplayPort Alternate Mode (Sink Side)						
L	H	L	L	L	Power Down	–
L	H	L	L	H	Power Down	–
L	H	L	H	L	One Port USB 3.1 - No Flip	–
L	H	L	H	H	One Port USB 3.1 – With Flip	–
L	H	H	L	L	4 Lane DP - No Flip	C and E
L	H	H	L	H	4 Lane DP – With Flip	C and E
L	H	H	H	L	One Port USB 3.1 + 2 Lane DP- No Flip	D and F
L	H	H	H	H	One Port USB 3.1 + 2 Lane DP– With Flip	D and F
USB + Custom Alternate Mode (Source Side)						
H	L	L	L	L	Power Down	–
H	L	L	L	H	Power Down	–
H	L	L	H	L	One Port USB 3.1 - No Flip	–
H	L	L	H	H	One Port USB 3.1 – With Flip	–
H	L	H	L	L	4 Channel Custom Alt Mode - No Flip	–
H	L	H	L	H	4 Channel Custom Alt Mode– With Flip	–
H	L	H	H	L	One Port USB 3.1 + 2 Channel Custom Alt Mode- No Flip	–
H	L	H	H	H	One Port USB 3.1 + 2 Channel Custom Alt Mode – With Flip	–
USB + Custom Alternate Mode (Sink Side)						
H	H	L	L	L	Power Down	–
H	H	L	L	H	Power Down	–
H	H	L	H	L	One Port USB 3.1 - No Flip	–
H	H	L	H	H	One Port USB 3.1 – With Flip	–
H	H	H	L	L	4 Channel Custom Alt Mode - No Flip	–

表 5. I2C Configuration Control (接下页)

Registers					TUSB1044 Configuration	VESA DisplayPort Alt Mode DFP_D Configuration
DIRSEL1	DIRSEL0	CTLSEL1	CTLSEL0	FLIPSEL		
H	H	H	L	H	4 Channel Custom Alt Mode– With Flip	–
H	H	H	H	L	One Port USB 3.1 + 2 Channel Custom Alt Mode– No Flip	–
H	H	H	H	H	One Port USB 3.1 + 2 Channel Custom Alt Mode – With Flip	–

表 6. I2C AUXP/N to SBU1/2 Mapping

Registers			Mapping
AUX_SBU_OVR	CTLSEL1	FLIPSEL	
00	H	L	AUXp -> SBU1 AUXn -> SBU2
00	H	H	AUXp -> SBU2 AUXn -> SBU1
00	L	X	Open
01	X	X	AUXp -> SBU1 AUXn -> SBU2
10	X	X	AUXp -> SBU2 AUXn -> SBU1
11	X	X	Open

7.4.3 DisplayPort Mode

The TUSB1044 supports up to four DisplayPort lanes at data rates up to 8.1Gbps. TUSB1044 can be enabled for DisplayPort through GPIO control or through I2C register control. When in GPIO mode, DisplayPort is controlled based on 表 2. When not in GPIO mode, enable of DisplayPort functionality is controlled through I²C registers.

7.4.4 Custom Alternate Mode

The TUSB1044 supports up to two lanes (or 4 channels) of custom Alternate Mode at data rates up to 10 Gbps. TUSB1044 can be enabled for custom Alternate Mode through GPIO control or through I²C register control. Custom Alternate mode is not supported for GPIO mode which has AUX snoop disabled. When in GPIO mode, custom Alternate Mode is controlled based on 表 2. When not in GPIO mode, enable of custom Alternate Mode functionality is controlled through I2C registers. In I2C mode, the operation of this mode requires leaving AUX_SNOOP_DISABLE register 13h bit 7 at 0.

7.4.5 Linear EQ Configuration

TUSB1044 receiver lanes have controls for receiver equalization for upstream and downstream facing ports. The receiver equalization gain value can be controlled either through I2C registers or through GPIOs. 表 7 details the gain value for each available combination when TUSB1044 is in GPIO mode. These same options are also available per channel and for upstream and downstream facing ports in I2C mode by updating registers URX[2:1]EQ_SEL, UTX[2:1]EQ_SEL, DRX[2:1]EQ_SEL, and DTX[2:1]EQ_SEL.

表 7. TUSB1044 Receiver Equalization GPIO Control

EQ Setting #	Downstream Facing Ports using 1100mV linearity setting				Upstream Facing Port using 1100mV linearity setting			
	DEQ1 pin Level	DEQ0 pin Level	EQ GAIN 5GHz (dB)	EQ GAIN 4.05GHz (dB)	UEQ1 pin Level	UEQ0 pin Level	EQ GAIN 5GHz (dB)	EQ GAIN 4.05GHz (dB)
0	0	0	-2.1	-1.4	0	0	-4.4	-3.3
1	0	R	0	0.4	0	R	-2.2	-1.5
2	0	F	1.5	1.7	0	F	0.7	0.0

表 7. TUSB1044 Receiver Equalization GPIO Control (接下页)

	Downstream Facing Ports using 1100mV linearity setting				Upstream Facing Port using 1100mV linearity setting			
3	0	1	3.0	3.2	0	1	0.9	1.4
4	R	0	4.0	4.1	R	0	1.9	2.4
5	R	R	5.0	5.2	R	R	3.0	3.5
6	R	F	5.9	6.1	R	F	3.8	4.3
7	R	1	6.7	6.9	R	1	4.7	5.2
8	F	0	7.4	7.7	F	0	5.4	6.0
9	F	R	8.0	8.3	F	R	6.0	6.6
10	F	F	8.5	8.8	F	F	6.5	7.2
11	F	1	9.0	9.4	F	1	7.1	7.7
12	1	0	9.4	9.8	1	0	7.5	8.1
13	1	R	9.8	10.3	1	R	7.9	8.6
14	1	F	10.1	10.6	1	F	8.3	9.0
15	1	1	10.5	11.0	1	1	8.6	9.4

7.4.6 Adjustable VOD Linear Range and DC Gain

The CFG0 and CFG1 pins can be used to adjust the TUSB1044 differential output voltage (VOD) swing linear range and receiver equalization DC gain for both downstream and upstream data path directions. 表 8 details the available options.

表 8. VOD Linear Range and DC Gain

Setting #	CFG1 pin Level	CFG0 pin Level	Downstream DC Gain (dB)	Upstream DC Gain (dB)	Downstream VOD Linear Range (mVpp)	Upstream VOD Linear Range (mVpp)
0	0	0	1	0	900	900
1	0	R	0	1	900	900
2	0	F	0	0	900	900
3	0	1	1	1	900	900
4	R	0	0	0	1100	1100
5	R	R	1	0	1100	1100
6	R	F	0	1	1100	1100
7	R	1	2	2	1100	1100
8	F	0	Reserved	Reserved	Reserved	Reserved
9	F	R	Reserved	Reserved	Reserved	Reserved
10	F	F	0	0	1300	1300
11	F	1	Reserved	Reserved	Reserved	Reserved
12	1	0	Reserved	Reserved	Reserved	Reserved
13	1	R	Reserved	Reserved	Reserved	Reserved
14	1	F	Reserved	Reserved	Reserved	Reserved
15	1	1	Reserved	Reserved	Reserved	Reserved

7.4.7 USB3.1 Modes

The TUSB1044 monitors the physical layer conditions like receiver termination, electrical idle, LFPS, and SuperSpeed signaling rate to determine the state of the USB3.1 interface. Depending on the state of the USB 3.1 interface, the TUSB1044 can be in one of four primary modes of operation when USB 3.1 is enabled (CTL0 = H or CTLSEL0 = 1b1): Disconnect, U2/U3, U1, and U0.

The Disconnect mode is the state in which TUSB1044 has not detected far-end termination on both upstream facing port (UFP) or downstream facing port (DFP). The disconnect mode is the lowest power mode of each of the four modes. The TUSB1044 remains in this mode until far-end receiver termination has been detected on both UFP and DFP. The TUSB1044 immediately exits this mode and enter U0 once far-end termination is detected.

Once in U0 mode, the TUSB1044 redrives all traffic received on UFP and DFP. U0 is the highest power mode of all USB3.1 modes. The TUSB1044 remains in U0 mode until electrical idle occurs on both UFP and DFP. Upon detecting electrical idle, the TUSB1044 immediately transitions to U1.

The U1 mode is the intermediate mode between U0 mode and U2/U3 mode. In U1 mode, the TUSB1044 UFP and DFP receiver termination remain enabled. The UFP and DFP transmitter DC common mode is maintained. The power consumption in U1 is similar to power consumption of U0.

Next to the disconnect mode, the U2 and U3 mode is next lowest power state. While in this mode, the TUSB1044 periodically performs far-end receiver detection. Anytime the far-end receiver termination is not detected on either UFP or DFP, the TUSB1044 leaves the U2 and U3 mode and transition to the Disconnect mode. It also monitors for a valid LFPS. Upon detection of a valid LFPS, the TUSB1044 immediately transitions to the U0 mode. In U2 and U3 mode, the TUSB1044 receiver terminations remains enabled, but the TX DC common mode voltage is not maintained.

When SLP_S0# is asserted low, it disables Receiver Detect functionality. While SLP_S0# is low and TUSB1044 is in U2 and U3, TUSB1044 disables LOS and LFPS detection circuitry and RX termination for both channels remains enabled. This allows even lower TUSB1044 power consumption while in the U2 and U3 mode. Once SLP_S0# is asserted high, the TUSB1044 will again start performing far-end receiver detection as well as monitor LFPS so it can know when to exit the U2 and U3 mode.

When SLP_S0# is asserted low and the TUSB1044 is in Disconnect mode, the TUSB1044 will remain in Disconnect mode and never perform far-end receiver detection. This allows even lower TUSB1044 power consumption while in the Disconnect mode. Once SLP_S0# is asserted high, the TUSB1044 will again start performing far-end receiver detection so it can know when to exit the Disconnect mode.

7.5 Programming

For further programmability, the TUSB1044 can be controlled using I²C. The SCL and SDA terminals are used for I²C clock and I²C data respectively.

表 9. I2C Slave Address

TUSB1044 I2C Slave Address									
UEQ1/A1 Pin Level	UEQ0/A0 Pin Level	Bit 7 (MSB)	Bit 6	Bit 5	Bit 4	Bit 3	Bit 2	Bit 1	Bit 0 (W/R)
0	0	1	0	0	0	1	0	0	0/1
0	R	1	0	0	0	1	0	1	0/1
0	F	1	0	0	0	1	1	0	0/1
0	1	1	0	0	0	1	1	1	0/1
R	0	0	1	0	0	0	0	0	0/1
R	R	0	1	0	0	0	0	1	0/1
R	F	0	1	0	0	0	1	0	0/1
R	1	0	1	0	0	0	1	1	0/1
F	0	0	0	1	0	0	0	0	0/1
F	R	0	0	1	0	0	0	1	0/1
F	F	0	0	1	0	0	1	0	0/1
F	1	0	0	1	0	0	1	1	0/1
1	0	0	0	0	1	1	0	0	0/1
1	R	0	0	0	1	1	0	1	0/1
1	F	0	0	0	1	1	1	0	0/1
1	1	0	0	0	1	1	1	1	0/1

7.5.1 Use The Following Procedure to Write to TUSB1044 I²C Registers:

1. The master initiates a write operation by generating a start condition (S), followed by the TUSB1044 7-bit address and a zero-value “W/R” bit to indicate a write cycle .
2. The TUSB1044 acknowledges the address cycle.
3. The master presents the sub-address (I²C register within TUSB1044) to be written, consisting of one byte of data, MSB-first.
4. The TUSB1044 acknowledges the sub-address cycle.
5. The master presents the first byte of data to be written to the I²C register.
6. The TUSB1044 acknowledges the byte transfer.
7. The master may continue presenting additional bytes of data to be written, with each byte transfer completing with an acknowledge from the TUSB1044.
8. The master terminates the write operation by generating a stop condition (P).

7.5.2 Use The Following Procedure to Read the TUSB1044 I²C Registers:

1. The master initiates a read operation by generating a start condition (S), followed by the TUSB1044 7-bit address and a one-value “W/R” bit to indicate a read cycle
2. The TUSB1044 acknowledges the address cycle.
3. The TUSB1044 transmit the contents of the memory registers MSB-first starting at register 00h or last read sub-address+1. If a write to the T I2C register occurred prior to the read, then the TUSB1044 shall start at the sub-address specified in the write.
4. The TUSB1044 shall wait for either an acknowledge (ACK) or a not-acknowledge (NACK) from the master after each byte transfer; the I²C master acknowledges reception of each data byte transfer.
5. If an ACK is received, the TUSB1044 transmits the next byte of data.
6. The master terminates the read operation by generating a stop condition (P).

7.5.3 Use The Following Procedure for Setting a Starting Sub-Address for I²C Reads:

1. The master initiates a write operation by generating a start condition (S), followed by the TUSB1044 7-bit address and a zero-value “W/R” bit to indicate a write cycle.
2. The TUSB1044 acknowledges the address cycle.
3. The master presents the sub-address (I2C register within TUSB1044) to be written, consisting of one byte of data, MSB-first.
4. The TUSB1044 acknowledges the sub-address cycle.
5. The master terminates the write operation by generating a stop condition (P).

注

If no sub-addressing is included for the read procedure, and reads start at register offset 00h and continue byte by byte through the registers until the I²C master terminates the read operation. If a I²C address write occurred prior to the read, then the reads start at the sub-address specified by the address write.

7.6 Register Maps

7.6.1 TUSB1044 Registers

Table 10 lists the memory-mapped registers for the TUSB1044. All register offset addresses not listed in Table 10 should be considered as reserved locations and the register contents should not be modified.

Table 10. TUSB1044 Registers

Offset	Acronym	Register Name	Section
Ah	General_1	General Registers 1	Go
Bh	General_2	General Registers 2	Go
Ch	General_3	General Registers 3	Go
10h	UFP2_EQ	UFP2 EQ Control	Go
11h	UFP1_EQ	UFP1 EQ Control	Go
12h	DisplayPort_1	AUX Snoop Status	Go
13h	DisplayPort_2	DP Lane Enable/Disable Control	Go
1Bh	SOFT_RESET	I2C and DPCD Soft Resets	Go
20h	DFP2_EQ	DFP2 EQ Control	Go
21h	DFP1_EQ	DFP1 EQ Control	Go
22h	USB3_MISC	Misc USB3 Controls	Go
23h	USB3_LOS	USB3 LOS Threshold Controls	Go

Complex bit access types are encoded to fit into small table cells. Table 11 shows the codes that are used for access types in this section.

Table 11. TUSB1044 Access Type Codes

Access Type	Code	Description
Read Type		
R	R	Read
RH	H R	Set or cleared by hardware Read
Write Type		
H	H	Set or cleared by hardware
W	W	Write
WSH	H W WS	Set or cleared by hardware Write
Reset or Default Value		
-n		Value after reset or the default value
Register Array Variables		
i,j,k,l,m,n		When these variables are used in a register name, an offset, or an address, they refer to the value of a register array where the register is part of a group of repeating registers. The register groups form a hierarchical structure and the array is represented with a formula.
y		When this variable is used in a register name, an offset, or an address it refers to the value of a register array.

7.6.1.1 General_1 Register (Offset = Ah) [reset = 1h]

General_1 is shown in [Figure 23](#) and described in [Table 12](#).

Return to [Summary Table](#).

Figure 23. General_1 Register

7	6	5	4	3	2	1	0
RESERVED	RESERVED	SWAP_SEL	EQ_OVERRID E	HPDIN_OVER RIDE	FLIP_SEL	CTLSEL[1:0]	
R-0h	R/W-0h	R/W-0h	R/W-0h	R/W-0h	R/W-0h	R/W-1h	

Table 12. General_1 Register Field Descriptions

Bit	Field	Type	Reset	Description
7	RESERVED	R	0h	Reserved
6	RESERVED	R/W	0h	Reserved
5	SWAP_SEL	R/W	0h	Setting this field performs a global direction swap on all the channels. 0h = Channel directions and EQ settings are in normal mode 1h = Reverse all channel directions and EQ settings for the input ports.
4	EQ_OVERRIDE	R/W	0h	Setting this field will allow software to use EQ settings from registers instead of value sampled from pins. 0h = EQ settings based on sampled state of EQ pins. 1h = EQ settings based on programmed value of each of the EQ registers.
3	HPDIN_OVERRIDE	R/W	0h	Overrides HPDIN pin state. 0h = HPD_IN based on HPD_IN pin. 1h = HPD_IN high.
2	FLIP_SEL	R/W	0h	FLIPSEL 0h = Normal Orientation 1h = Flip orientation.
1-0	CTLSEL[1:0]	R/W	1h	Controls the DP and USB modes. 0h = Disabled. All RX and TX for USB3 and DisplayPort are disabled. 1h = USB3.1 only enabled. 2h = Four Lanes of DisplayPort enabled. 3h = USB3.1 and Two DisplayPort Lanes.

7.6.1.2 General_2 Register (Offset = Bh) [reset = 0h]

General_2 is shown in Figure 24 and described in Table 13.

Return to [Summary Table](#).

Figure 24. General_2 Register

7	6	5	4	3	2	1	0
RESERVED				CH_SWAP_SEL			
R-0h				R/W-0h			

Table 13. General_2 Register Field Descriptions

Bit	Field	Type	Reset	Description
7-4	RESERVED	R	0h	Reserved
3-0	CH_SWAP_SEL	R/W	0h	Swaps direction (TX to Rx and Rx to Tx) and EQ settings of individual channels. Channels are numbered from 0 to 3. 1 bit per lane. 0h = Channel and EQ settings normal. 1h = Reverse channel direction and EQ setting.

7.6.1.3 General_3 Register (Offset = Ch) [reset = 0h]

General_3 is shown in Figure 25 and described in Table 14.

Return to [Summary Table](#).

Figure 25. General_3 Register

7	6	5	4	3	2	1	0
RESERVED	VOD_DCGAIN_OVERRIDE	VOD_DCGAIN_SEL				DIR_SEL	
R-0h	R/W-0h	R/W-0h				R/W-0h	

Table 14. General_3 Register Field Descriptions

Bit	Field	Type	Reset	Description
7	RESERVED	R	0h	Reserved
6	VOD_DCGAIN_OVERRIDE	R/W	0h	Setting of this field will allow software to use VOD linearity range and DC gain settings from registers instead of value sampled from pins 0h = VOD linearity and DC gain settings based on sampled CFG[2:1] pins. 1h = EQ settings based on programmed value of each VOD linearity and DC Gain registers.
5-2	VOD_DCGAIN_SEL	R/W	0h	Field selects VOD linearity range and DC gain for all the channels and in all directions. When VOD_DCGAIN_OVERRIDE = 0b, this field reflects the sampled state of CFG[1:0] pins. When VOD_DCGAIN_OVERRIDE = 1b software can change the VOD linearity range and DC gain for all the channels and in all directions based on value written to this field. Each CFG is a 2-bit value. The register-to-CFG1/0 mapping is: [5:2] = {CFG1[1:0], CFG0[1:0]} where CFGx[1:0] mapping is: 0h = 0 1h = R 2h = F 3h = 1

Table 14. General_3 Register Field Descriptions (continued)

Bit	Field	Type	Reset	Description
1-0	DIR_SEL	R/W	0h	Sets the operation mode. 0h = USB + DP Alt Mode Source 1h = USB + DP Alt Mode Sink. 2h = USB + Custom Alt Mode Source 3h = USB + Custom Alt Mode Sink.

7.6.1.4 UFP2_EQ Register (Offset = 10h) [reset = 0h]

UFP2_EQ is shown in [Figure 26](#) and described in [Table 15](#).

Return to [Summary Table](#).

Figure 26. UFP2_EQ Register

7	6	5	4	3	2	1	0
UTX2EQ_SEL				URX2EQ_SEL			
R/W-0h				R/W-0h			

Table 15. UFP2_EQ Register Field Descriptions

Bit	Field	Type	Reset	Description
7-4	UTX2EQ_SEL	R/W	0h	Field selects EQ for UTX2P/N pins. When EQ_OVERRIDE = 0b, this field reflects the sampled state of UEQ[1:0] pins. When EQ_OVERRIDE = 1b, software can change the EQ setting for UTX2P/N pins based on value written to this field.
3-0	URX2EQ_SEL	R/W	0h	Field selects EQ for URX2P/N pins. When EQ_OVERRIDE = 0b, this field reflects the sampled state of UEQ[1:0] pins. When EQ_OVERRIDE = 1b, software can change the EQ setting for URX2P/N pins based on value written to this field.

7.6.1.5 UFP1_EQ Register (Offset = 11h) [reset = 0h]

UFP1_EQ is shown in [Figure 27](#) and described in [Table 16](#).

Return to [Summary Table](#).

Figure 27. UFP1_EQ Register

7	6	5	4	3	2	1	0
UTX1EQ_SEL				URX1EQ_SEL			
R/W-0h				R/W-0h			

Table 16. UFP1_EQ Register Field Descriptions

Bit	Field	Type	Reset	Description
7-4	UTX1EQ_SEL	R/W	0h	Field selects EQ for UTX1P/N pins. When EQ_OVERRIDE = 0b, this field reflects the sampled state of UEQ[1:0] pins. When EQ_OVERRIDE = 1b, software can change the EQ setting for UTX1P/N pins based on value written to this field.
3-0	URX1EQ_SEL	R/W	0h	Field selects EQ for URX1P/N pins. When EQ_OVERRIDE = 0b, this field reflects the sampled state of UEQ[1:0] pins. When EQ_OVERRIDE = 1b, software can change the EQ setting for URX1P/N pins based on value written to this field.

7.6.1.6 DisplayPort_1 Register (Offset = 12h) [reset = 0h]

 DisplayPort_1 is shown in [Figure 28](#) and described in [Table 17](#).

 Return to [Summary Table](#).

Figure 28. DisplayPort_1 Register

7	6	5	4	3	2	1	0
RESERVED	SET_POWER_STATE		LANE_COUNT_SET				
R-0h	RH-0h		RH-0h				

Table 17. DisplayPort_1 Register Field Descriptions

Bit	Field	Type	Reset	Description
7	RESERVED	R	0h	Reserved
6-5	SET_POWER_STATE	RH	0h	This field represents the snooped value of the AUX write to DPCD address 0x00600. When AUX_SNOOP_DISABLE = 0b, the enable/disable of DP lanes based on the snooped value. When AUX_SNOOP_DISABLE = 1b, then DP lane enable/disable are determined by state of DPx_DISABLE registers, where x = 0, 1, 2, or 3. This field is reset to 0h by hardware when CTLSEL1 changes from a 1b to a 0b.
4-0	LANE_COUNT_SET	RH	0h	This field represents the snooped value of AUX write to DPCD address 0x00101 register. When AUX_SNOOP_DISABLE = 0b, DP lanes enabled specified by the snoop value. Unused DP lanes will be disabled to save power. When AUX_SNOOP_DISABLE = 1b, then DP lanes enable/disable are determined by DPx_DISABLE registers, where x = 0, 1, 2, or 3. This field is reset to 0h by hardware when CTLSEL1 changes from a 1b to a 0b.

7.6.1.7 DisplayPort_2 Register (Offset = 13h) [reset = 0h]

DisplayPort_2 is shown in [Figure 29](#) and described in [Table 18](#).

Return to [Summary Table](#).

Figure 29. DisplayPort_2 Register

7	6	5	4	3	2	1	0
AUX_SNOOP_DISABLE	RESERVED	AUX_SBU_OVR	DP3_DISABLE	DP2_DISABLE	DP1_DISABLE	DP0_DISABLE	
R/W-0h	R-0h	R/W-0h	R/W-0h	R/W-0h	R/W-0h	R/W-0h	R/W-0h

Table 18. DisplayPort_2 Register Field Descriptions

Bit	Field	Type	Reset	Description
7	AUX_SNOOP_DISABLE	R/W	0h	Controls whether DP lanes are enabled based on AUX snooped value or registers. 0h = AUX snoop enabled. 1h = AUX snoop disabled. DP lanes are controlled by registers.
6	RESERVED	R	0h	Reserved
5-4	AUX_SBU_OVR	R/W	0h	This field overrides the AUXP/N to SBU1/2 connect and disconnect based on CTL1 and FLIP. Changing this field to 1b will allow traffic to pass through AUX to SBU regardless of the state of CTLSEL1 and FLIPSEL register. 0h = AUX to SBU connection determined by CTLSEL1 and FLIPSEL 1h = AUXP -> SBU1 and AUXN -> SBU2 2h = AUXP -> SBU2 and AUXN -> SBU1 3h = AUX to SBU open.
3	DP3_DISABLE	R/W	0h	When AUX_SNOOP_DISABLE = 1b, this field can be used to enable or disable DP lane 3. When AUX_SNOOP_DISABLE = 0b, changes to this field will have no effect on lane 3 functionality. 0h = DP Lane 3 enabled. 1h = DP Lane 3 disabled.
2	DP2_DISABLE	R/W	0h	When AUX_SNOOP_DISABLE = 1b, this field can be used to enable or disable DP lane 2. When AUX_SNOOP_DISABLE = 0b, changes to this field will have no effect on lane 2 functionality. 0h = DP Lane 2 enabled. 1h = DP Lane 2 disabled.
1	DP1_DISABLE	R/W	0h	When AUX_SNOOP_DISABLE = 1b, this field can be used to enable or disable DP lane 1. When AUX_SNOOP_DISABLE = 0b, changes to this field will have no effect on lane 1 functionality. 0h = DP Lane 1 enabled. 1h = DP Lane 1 disabled.
0	DP0_DISABLE	R/W	0h	When AUX_SNOOP_DISABLE = 1b, this field can be used to enable or disable DP lane 0. When AUX_SNOOP_DISABLE = 0b, changes to this field will have no effect on lane 0 functionality. 0h = DP Lane 0 enabled. 1h = DP Lane 0 disabled.

7.6.1.8 SOFT_RESET Register (Offset = 1Bh) [reset = 0h]

 SOFT_RESET is shown in [Figure 30](#) and described in [Table 19](#).

 Return to [Summary Table](#).

Figure 30. SOFT_RESET Register

7	6	5	4	3	2	1	0
I2C_RST	DPCD_RST	RESERVED					
RH/WS-0h	RH/WS-0h	R-0h					

Table 19. SOFT_RESET Register Field Descriptions

Bit	Field	Type	Reset	Description
7	I2C_RST	RH/WS	0h	Resets I2C registers to default values. This field is self-clearing.
6	DPCD_RST	RH/WS	0h	Resets DPCD registers to default values. This field is self-clearing.
5-0	RESERVED	R	0h	Reserved

7.6.1.9 DFP2_EQ Register (Offset = 20h) [reset = 0h]

 DFP2_EQ is shown in [Figure 31](#) and described in [Table 20](#).

 Return to [Summary Table](#).

Figure 31. DFP2_EQ Register

7	6	5	4	3	2	1	0
DTX2EQ_SEL				DRX2EQ_SEL			
R/W-0h				R/W-0h			

Table 20. DFP2_EQ Register Field Descriptions

Bit	Field	Type	Reset	Description
7-4	DTX2EQ_SEL	R/W	0h	Field selects EQ for DTX2P/N pins. When EQ_OVERRIDE = 0b, this field reflects the sampled state of DEQ[1:0] pins. When EQ_OVERRIDE = 1b, software can change the EQ setting for DTX2P/N pins based on value written to this field.
3-0	DRX2EQ_SEL	R/W	0h	Field selects EQ for DRX2P/N pins. When EQ_OVERRIDE = 0b, this field reflects the sampled state of DEQ[1:0] pins. When EQ_OVERRIDE = 1b, software can change the EQ setting for DRX2P/N pins based on value written to this field.

7.6.1.10 DFP1_EQ Register (Offset = 21h) [reset = 0h]

DFP1_EQ is shown in [Figure 32](#) and described in [Table 21](#).

Return to [Summary Table](#).

Figure 32. DFP1_EQ Register

7	6	5	4	3	2	1	0
DTX1EQ_SEL				DRX1EQ_SEL			
R/W-0h				R/W-0h			

Table 21. DFP1_EQ Register Field Descriptions

Bit	Field	Type	Reset	Description
7-4	DTX1EQ_SEL	R/W	0h	Field selects EQ for DTX1P/N pins. When EQ_OVERRIDE = 0b, this field reflects the sampled state of DEQ[1:0] pins. When EQ_OVERRIDE = 1b, software can change the EQ setting for DTX1P/N pins based on value written to this field.
3-0	DRX1EQ_SEL	R/W	0h	Field selects EQ for DRX1P/N pins. When EQ_OVERRIDE = 0b, this field reflects the sampled state of DEQ[1:0] pins. When EQ_OVERRIDE = 1b, software can change the EQ setting for DRX1P/N pins based on value written to this field.

7.6.1.11 USB3_MISC Register (Offset = 22h) [reset = 4h]

USB3_MISC is shown in [Figure 33](#) and described in [Table 22](#).

Return to [Summary Table](#).

Figure 33. USB3_MISC Register

7	6	5	4	3	2	1	0
CM_ACTIVE	LFPS_EQ	U2U3_LFPS_D EBOUNCE	DISABLE_U2U 3_RXDET	DFP_RXDET_INTERVAL		USB_COMPLIANCE_CTRL	
RH-0h	R/W-0h	R/W-0h	R/W-0h	R/W-1h		R/W-0h	

Table 22. USB3_MISC Register Field Descriptions

Bit	Field	Type	Reset	Description
7	CM_ACTIVE	RH	0h	Compliance mode status. 0h = Not in USB3.1 compliance mode. 1h = In USB3.1 compliance mode.
6	LFPS_EQ	R/W	0h	Controls whether settings of EQ based on URX[2:1]EQ_SEL, UTX[2:1]EQ_SEL, DRX[2:1]EQ_SEL, and DTX[2:1]EQ_SEL applies to received LFPS signal. 0h = EQ set to zero when receiving LFPS 1h = EQ set by the related registers when receiving LFPS.
5	U2U3_LFPS_DEBOUNCE	R/W	0h	Controls whether or not incoming LFPS is debounced or not. 0h = No debounce of LFPS before U2/U3 exit. 1h = 200us debounce of LFPS before U2/U3 exit.
4	DISABLE_U2U3_RXDET	R/W	0h	Controls whether or not Rx.Detect is performed in U2/U3 state. 0h = Rx.Detect in U2/U3 enabled. 1h = Rx.Detect in U2/U3 disabled.
3-2	DFP_RXDET_INTERVAL	R/W	1h	This field controls the Rx.Detect interval for the downstream facing port (DTX1P/N and DTX2P/N). 0h = 8ms 1h = 12ms 2h = Reserved 3h = Reserved.

Table 22. USB3_MISC Register Field Descriptions (continued)

Bit	Field	Type	Reset	Description
1-0	USB_COMPLIANCE_CTRL	R/W	0h	Controls whether compliance mode is determined by FSM or register. 0h = Compliance mode determined by FSM. 1h = Compliance mode enabled in DFP direction. 2h = Compliance mode enabled in UFP direction. 3h = Compliance mode disabled.

7.6.1.12 USB3_LOS Register (Offset = 23h) [reset = 23h]

 USB3_LOS is shown in [Figure 34](#) and described in [Table 23](#).

 Return to [Summary Table](#).

Figure 34. USB3_LOS Register

7	6	5	4	3	2	1	0
RESERVED		CFG_LOS_HYST			CFG_LOS_VTH		
R-0h		R/W-4h			R/W-3h		

Table 23. USB3_LOS Register Field Descriptions

Bit	Field	Type	Reset	Description
7-6	RESERVED	R	0h	Reserved
5-3	CFG_LOS_HYST	R/W	4h	Controls LOS hysteresis defined as 20 log (LOS de-assert threshold/LOS assert threshold). 0h = 0.15 dB 1h = 0.85 dB 2h = 1.45 dB 3h = 2.00 dB 4h = 2.70 dB 5h = 3.00 dB 6h = 3.40 dB 7h = 3.80 dB
2-0	CFG_LOS_VTH	R/W	3h	Controls LOS assert threshold voltage 0h = 67 mV 1h = 72 mV 2h = 79 mV 3h = 85 mV 4h = 91 mV 5h = 97 mV 6h = 105 mV 7h = 112 mV

8 Application and Implementation

注

Information in the following applications sections is not part of the TI component specification, and TI does not warrant its accuracy or completeness. TI's customers are responsible for determining suitability of components for their purposes. Customers should validate and test their design implementation to confirm system functionality.

8.1 Application Information

The TUSB1044 is a linear redriver designed specifically to compensate for intersymbol interference (ISI) jitter caused by signal attenuation through a passive medium like PCB traces and cables. Because the TUSB1044 has four independent inputs, it can be optimized to correct ISI on all those seven inputs through 16 different equalization choices. Placing the TUSB1044 between a USB3.1 Host/DisplayPort 1.4 GPU and a USB3.1 Type-C receptacle can correct signal integrity issues resulting in a more robust system.

8.2 Typical Application



图 35. TUSB1044 in a Host Application

Typical Application (接下页)

8.2.1 Design Requirements

For this design example, use the parameters shown in 表 24.

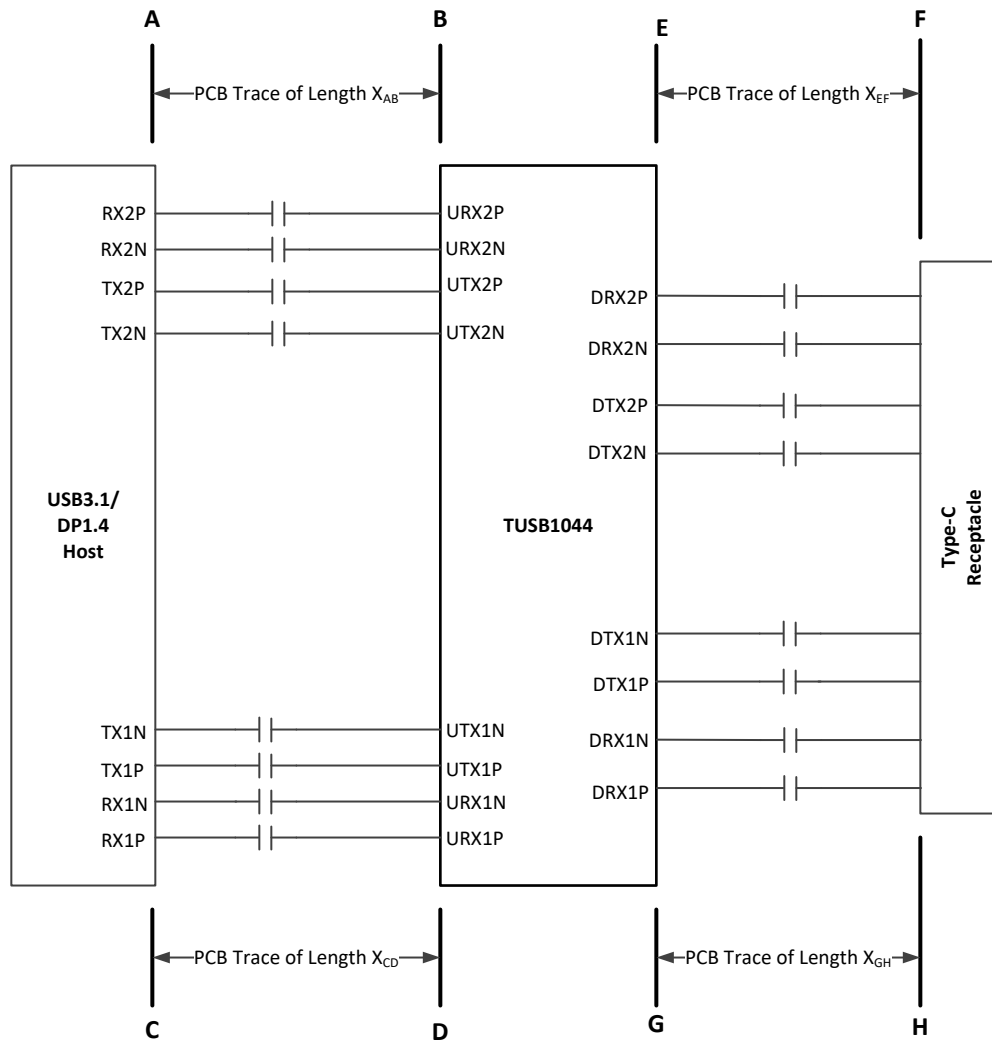
表 24. Design Parameters

PARAMETER	VALUE
A to B PCB trace length, X_{AB}	8 inches (assuming 1 dB/inch at 5GHz).
C to D PCB trace length, X_{CD}	8 inches (assuming 1 dB/inch at 5GHz).
E to F PCB trace length, X_{EF}	1.5 inches (assuming 1 dB/inch at 5GHz).
G to H PCB trace length, X_{GH}	1.5 inches (assuming 1 dB/inch at 5GHz).
PCB trace width	4 mils
AC-coupling capacitor (75 nF to 265 nF)	220 nF
VCC supply (3 V to 3.6 V)	3.3 V
I2C Mode or GPIO Mode	I2C Mode.
1.8V or 3.3V I2C Interface	3.3V I2C. Pull-up the I2C_EN pin to 3.3V with a 1K ohm resistor.

8.2.2 Detailed Design Procedure

A typical usage of the TUSB1044 device is shown in 图 36. The device can be controlled either through its GPIO pins or through its I²C interface. In 图 36, a Type-C PD controller is used to configure the device through the I²C interface. In I²C mode, the equalization settings for each receiver can be independently controlled through I²C registers. For this reason, all of the equalization pins (UEQ[1:0] and DEQ[1:0]) can be left unconnected. If these pins are left unconnected, the TUSB1044 7-bit I²C slave address is 12h because both UEQ1/A1 and UEQ0/A0 are at pin level "F". If a different I²C slave address is desired, UEQ1/A1 and UEQ0/A0 pins should be set to a level which produces the desired I²C slave address.

Recent ECN (Engineering Change Notice) to the USB3.1 specification allows for AC-coupling capacitors between USB receptacle and the USB3.1 receiver pins of a device/host/hub. The TUSB1044 does support the additional AC-capacitor as depicted in 图 36 on pins DRX2P/N and DRX1P/N. This AC-coupling capacitor should be no smaller than 297 nF. A value of 330 nF is recommended.



图 36. Typical Application Circuit

8.2.3 Application Curve

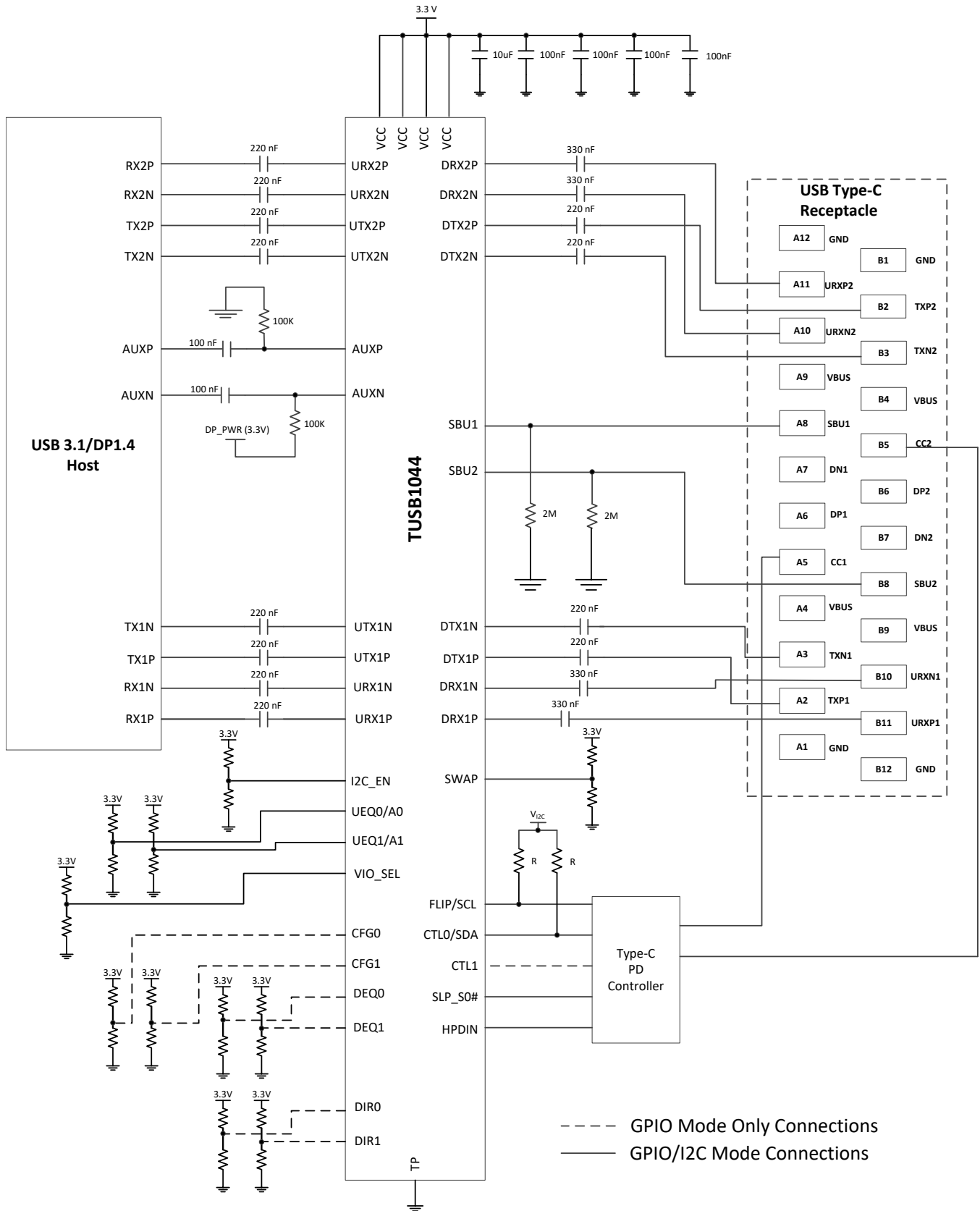

图 37. Insertion Loss of FR4 PCB Traces

8.3 System Examples

8.3.1 USB 3.1 only (USB/DP Alternate Mode)

The TUSB1044 is in USB3.1 only when the CTL1 pin is low and CTL0 pin is high.

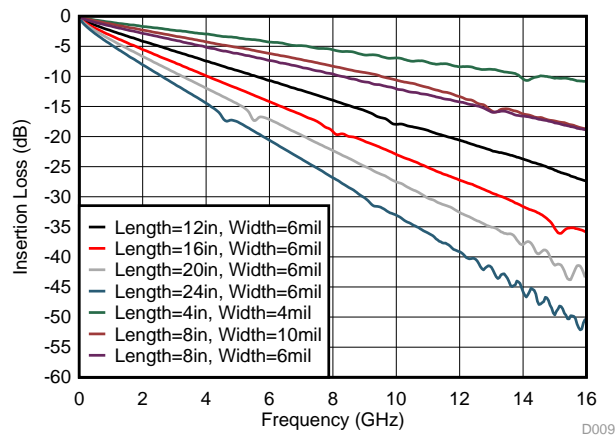

图 38. USB3.1 Only – No Flip



图 39. USB3.1 Only – With Flip

System Examples (接下页)

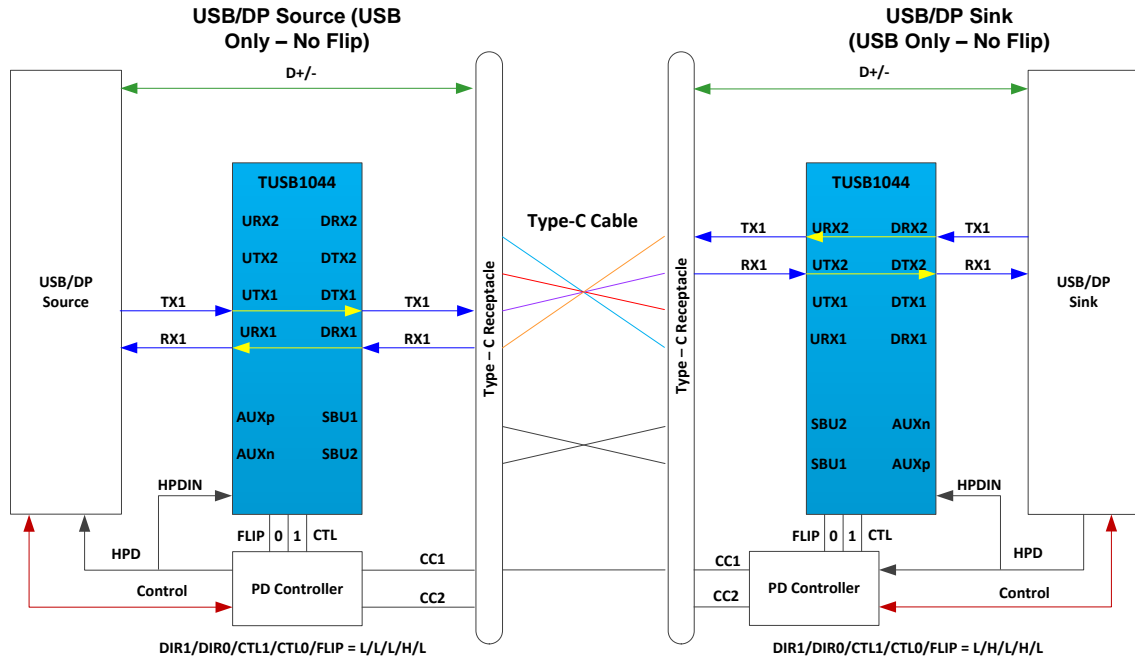
8.3.2 USB3.1 and 2 lanes of DisplayPort

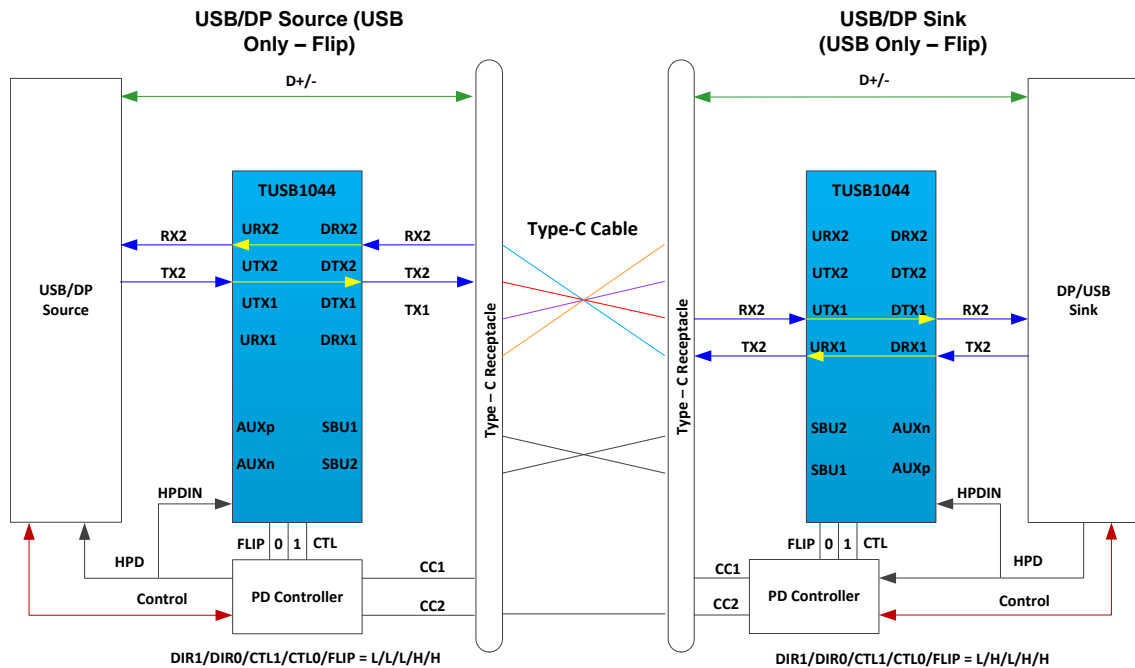

图 40. USB3.1 + 2 Lane DP – No Flip



图 41. USB 3.1 + 2 Lane DP – Flip

System Examples (接下页)

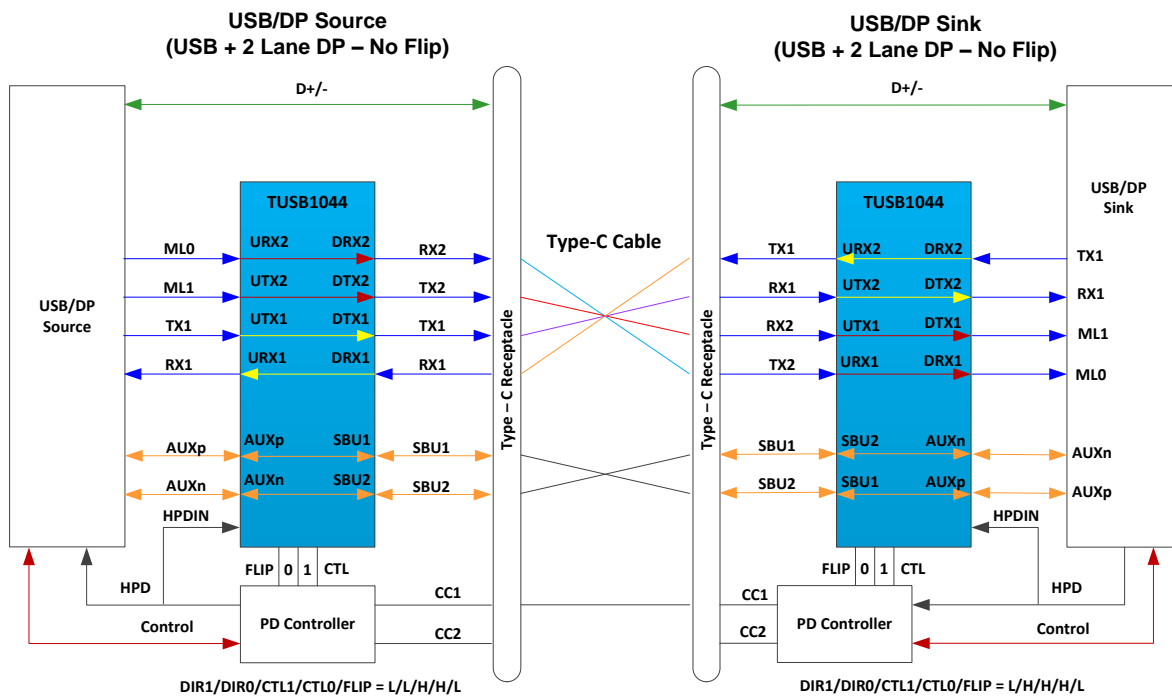
8.3.3 DisplayPort Only

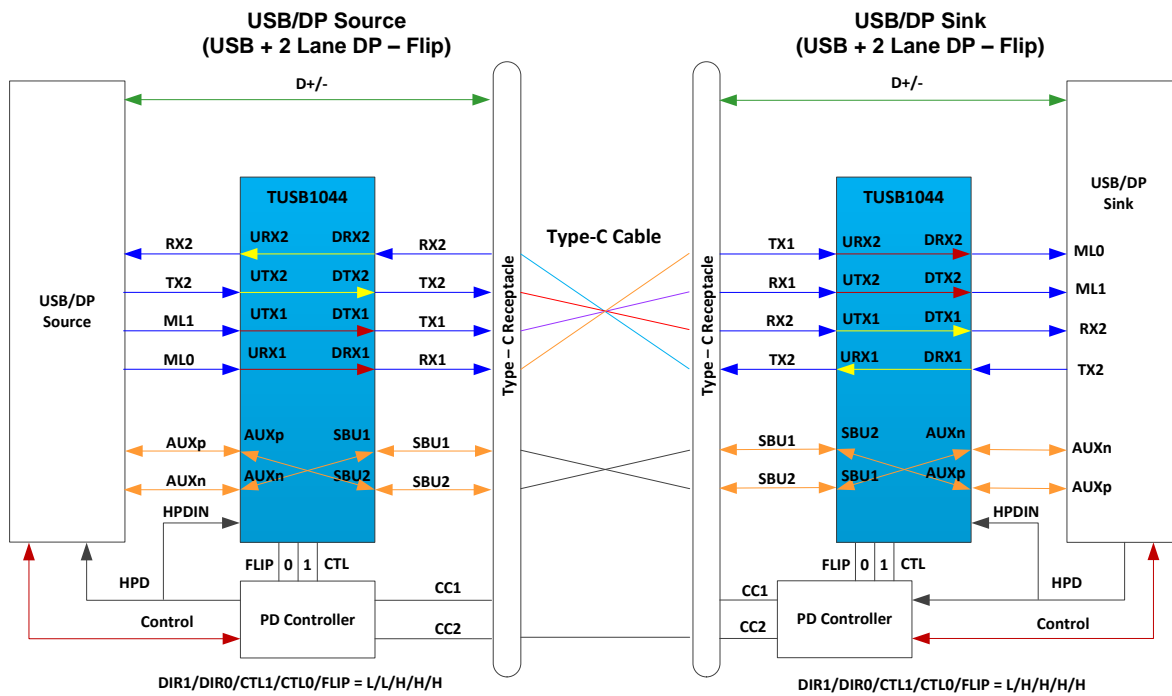

图 42. Four Lane DP – No Flip



图 43. Four Lane DP – With Flip

System Examples (接下页)

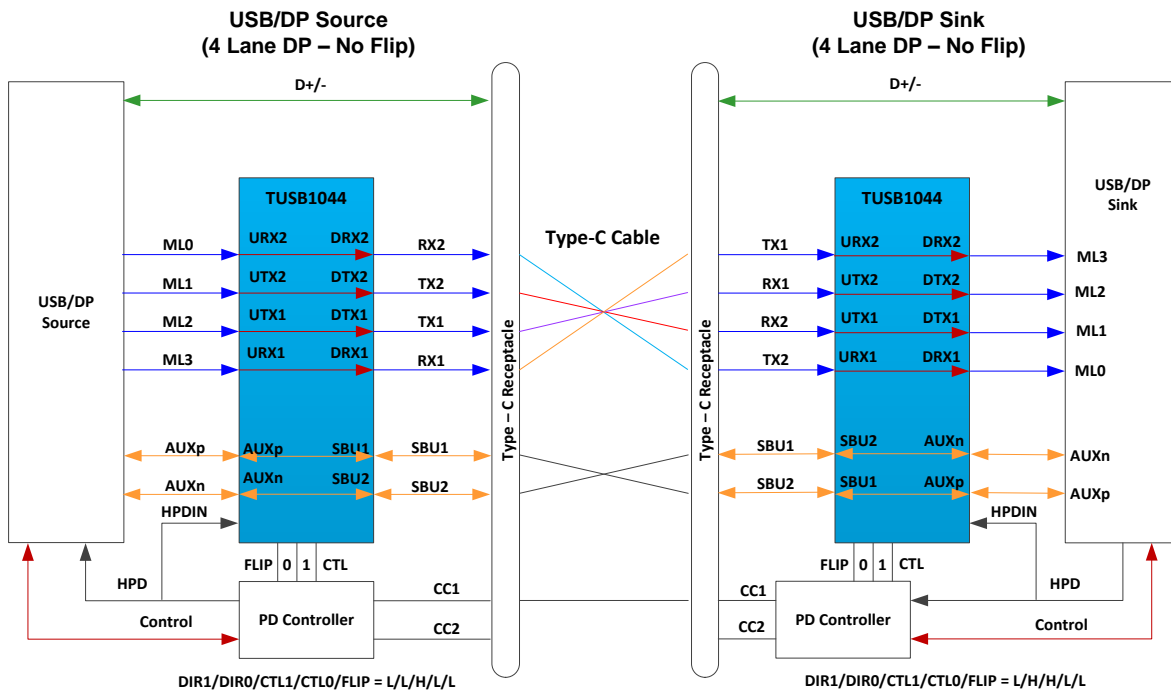
8.3.4 USB 3.1 only (USB/Custom Alternate Mode)

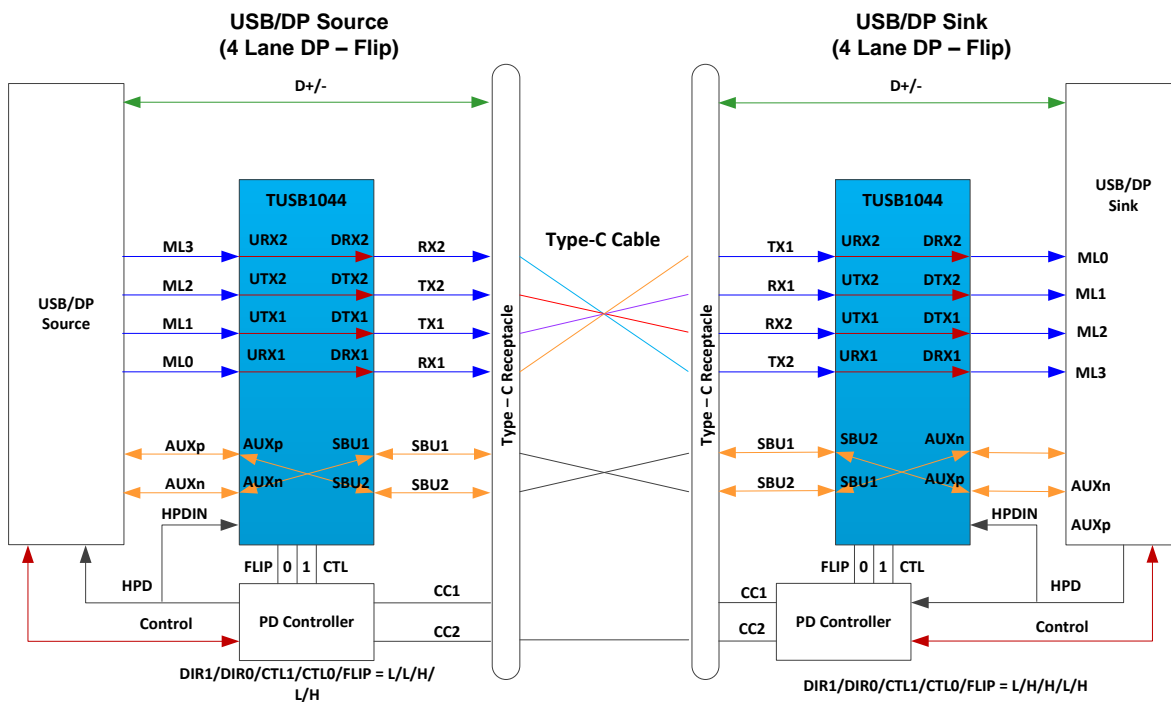

图 44. USB3.1 Only – No Flip



图 45. USB3.1 Only – With Flip

System Examples (接下页)

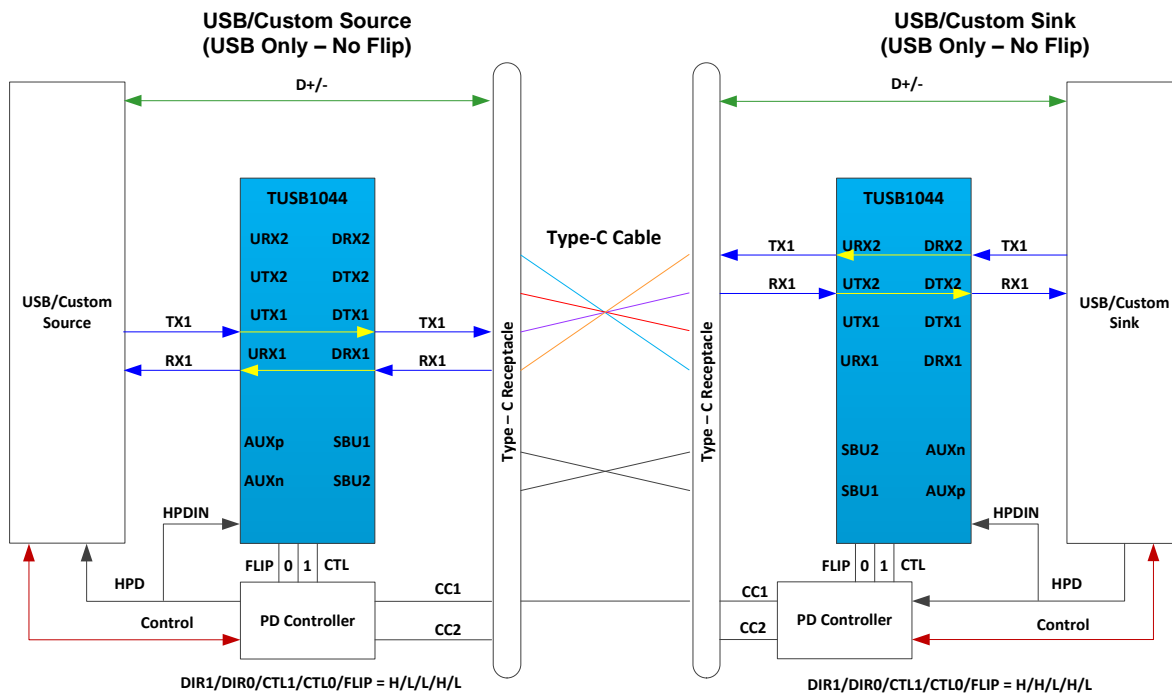
8.3.5 USB3.1 and 1 Lane of Custom Alt Mode

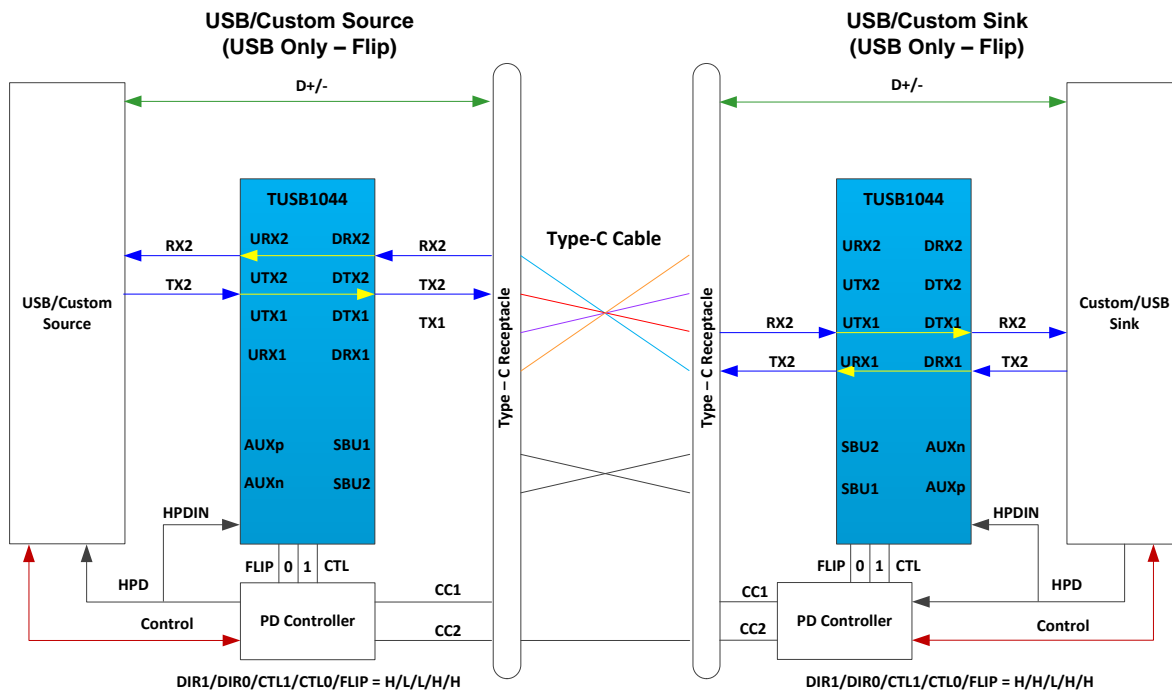

图 46. USB3.1 + 1 Lane Custom Alt Mode – No Flip



图 47. USB 3.1 + 1 Lane Custom Alt. Mode – Flip

System Examples (接下页)

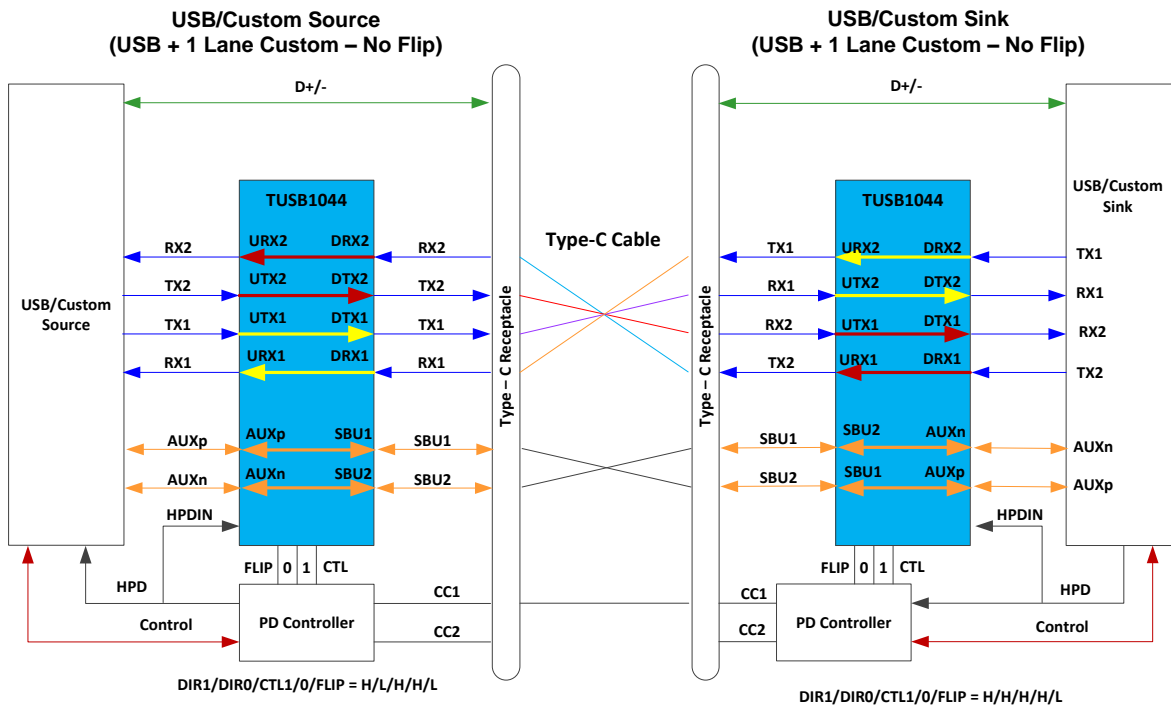
8.3.6 USB3.1 and 2 Lane of Custom Alt Mode

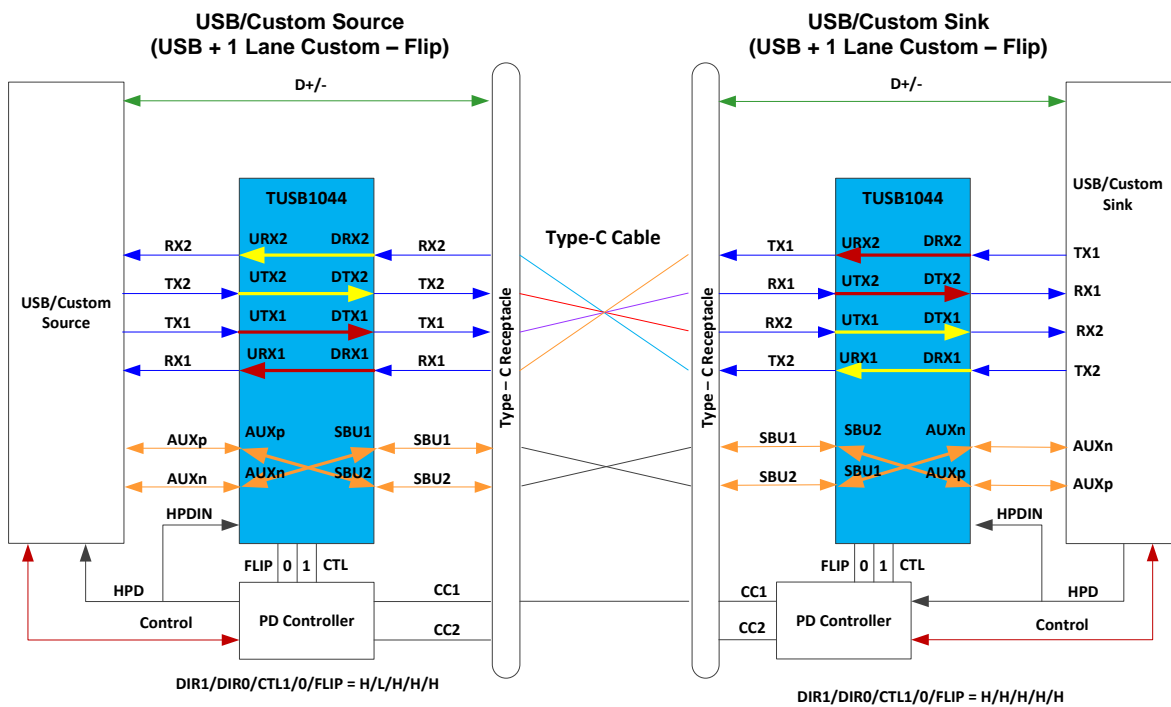

图 48. Two Lane Custom Alternate Mode – No Flip



图 49. Two Lane Custom Alternate Mode – With Flip

System Examples (接下页)

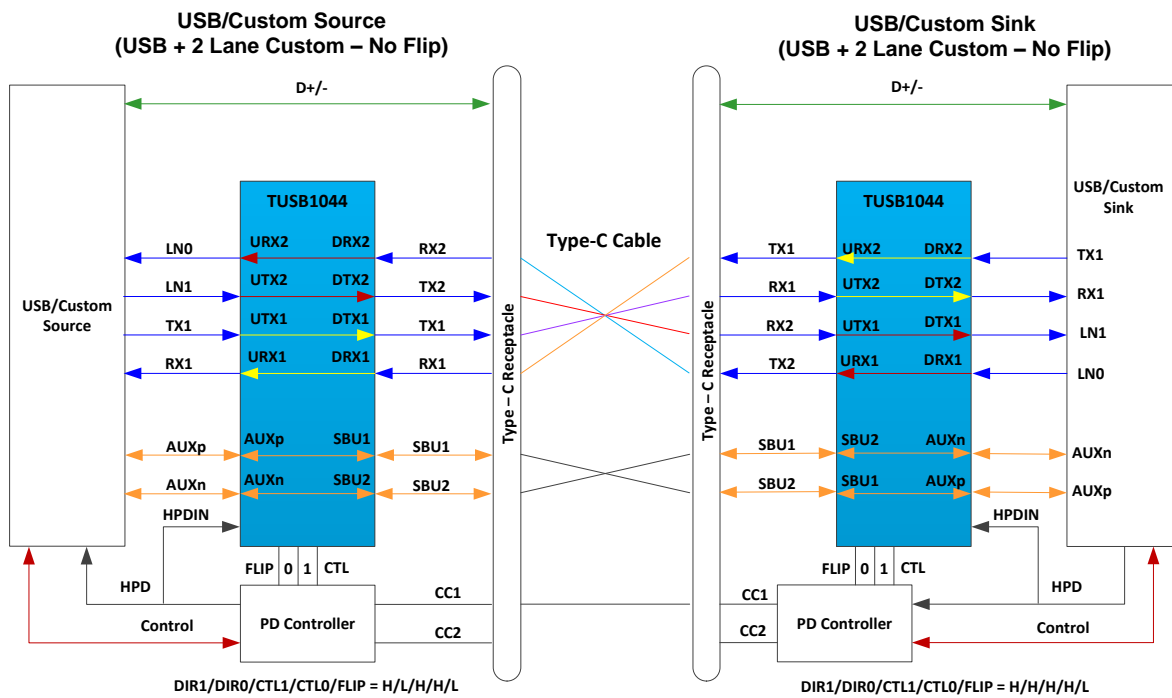
8.3.7 USB3.1 and 4 Lane of Custom Alt Mode

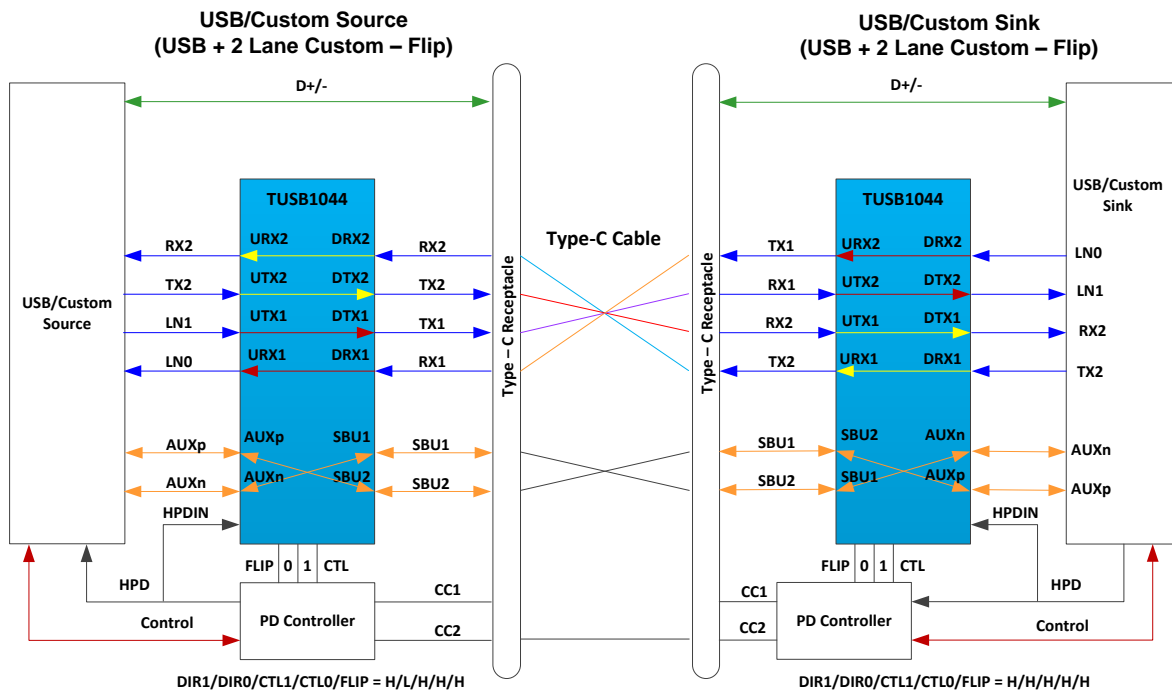

图 50. Four Lane Custom Alternate Mode – No Flip



图 51. Four Lane Custom Alternate Mode – With Flip

9 Power Supply Recommendations

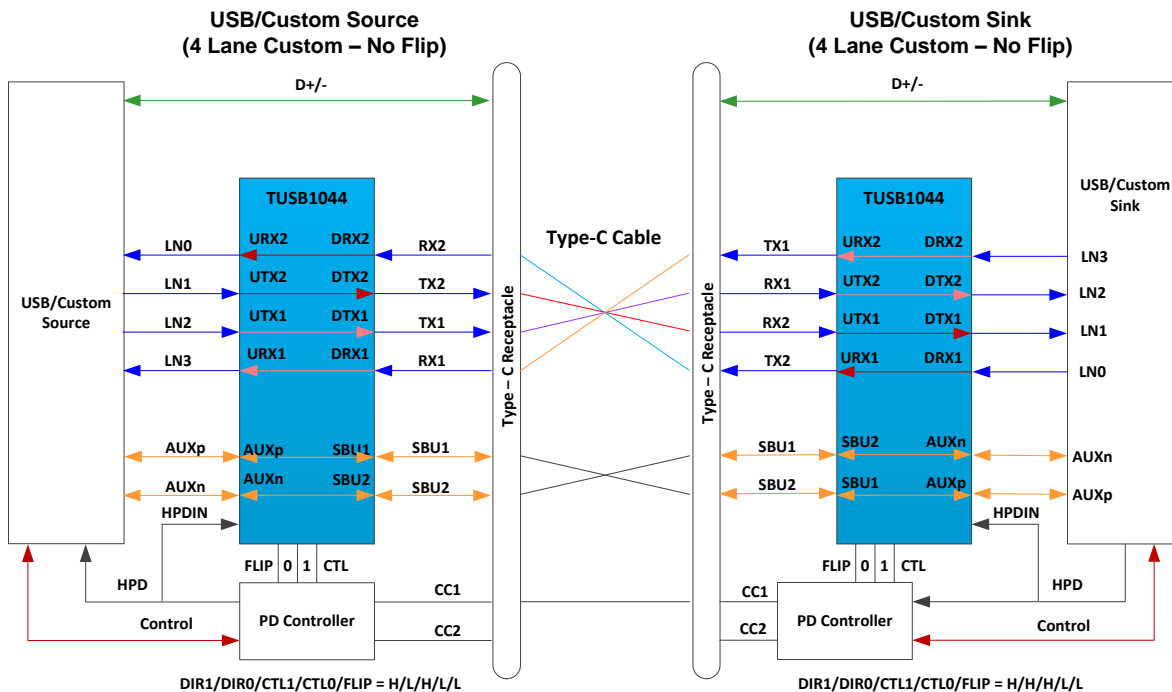
The TUSB1044 is designed to operate with a 3.3-V power supply. Levels above those listed in the table should not be used. If using a higher voltage system power supply, a voltage regulator can be used to step down to 3.3 V. Decoupling capacitors should be used to reduce noise and improve power supply integrity. A 0.1- μ F capacitor should be used on each power pin.

10 Layout

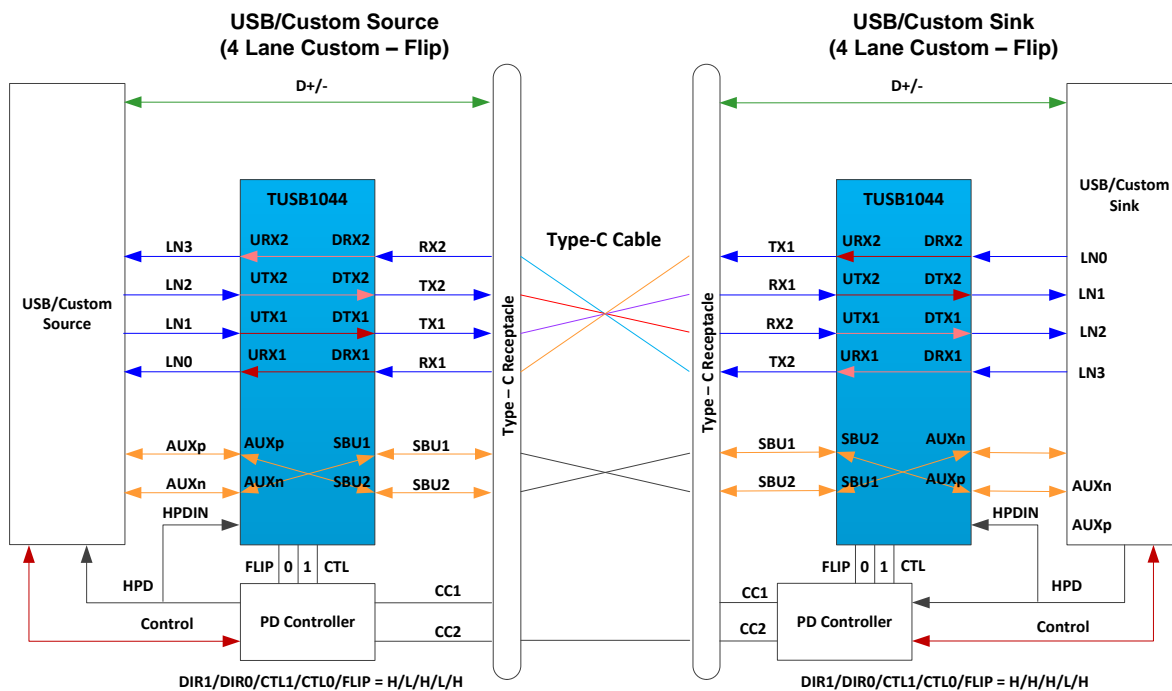
10.1 Layout Guidelines

1. RXP/N and TXP/N pairs should be routed with controlled 90-Ω differential impedance ($\pm 15\%$).
2. Keep away from other high speed signals.
3. Intra-pair routing should be kept to within 2 mils.
4. Length matching should be near the location of mismatch.
5. Each pair should be separated at least by 3 times the signal trace width.
6. The use of bends in differential traces should be kept to a minimum. When bends are used, the number of left and right bends should be as equal as possible and the angle of the bend should be ≥ 135 degrees. This will minimize any length mismatch causes by the bends and therefore minimize the impact bends have on EMI.
7. Route all differential pairs on the same of layer.
8. The number of VIAS should be kept to a minimum. It is recommended to have no more than 1 VIA between TUSB1044 and Type-C connector and no more than 1 VIA between TUSB1044 and USB3.1 Device/Host.
9. Keep traces on layers adjacent to ground plane.
10. Do NOT route differential pairs over any plane split.
11. Adding Test points will cause impedance discontinuity; and therefore, negatively impacts signal performance. If test points are used, the test points should be placed in series and symmetrically. The test points must not be placed in a manner that causes a stub on the differential pair.
12. Assuming 1 dB/inch loss at 5 GHz, the trace length between TUSB1044 and Type-C connector should be no more than 1.5 inches.
13. Assuming 1 dB/inch loss at 5 GHz, the trace length between TUSB1044 and the USB 3.1 Host/Device should be no more than 8 inches.
14. ESD protection devices and EMI suppression devices need to be carefully selected and have to have excellent transient performance at 10 Gbps with flat shunt capacitance characteristics over ± 650 mV voltage range. Note small-signal insertion loss characteristics are insufficient to determine suitability of non-linear devices (ESD devices) for 10Gbps operation

10.2 Layout Example



图 52. Example Layout

11 器件和文档支持

11.1 文档支持

11.1.1 相关文档

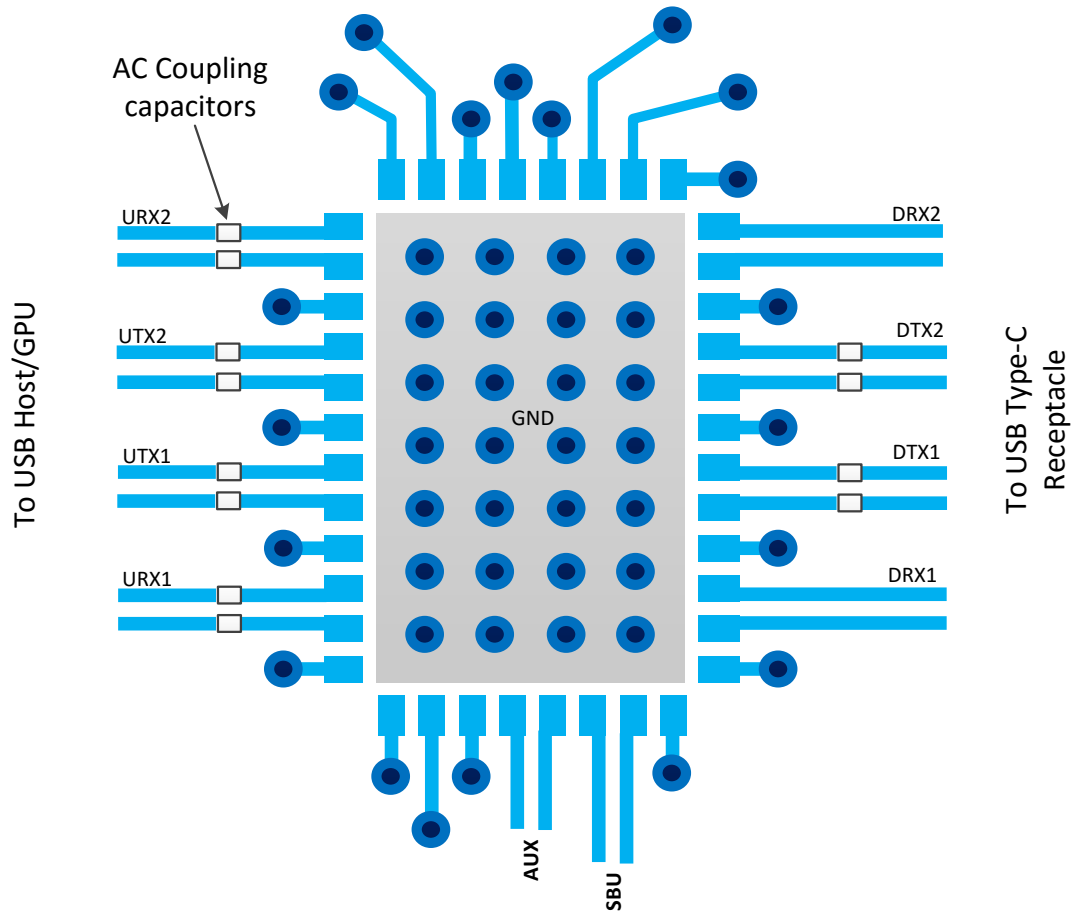
本节标识的文档均在本规范中引用。为简化文本，文中的大多数参考文献均用文档标签 [文档标签] 标识，而不使用完整的文档标题。

相关文档如下：

- [USB31] 通用串行总线 3.1 规范。
- [TYPEC] 通用串行总线 Type C 线缆和连接器规范

11.2 接收文档更新通知

要接收文档更新通知，请导航至 TI.com.cn 上的器件产品文件夹。单击右上角的 *通知我* 进行注册，即可每周接收产品信息更改摘要。有关更改的详细信息，请查看任何已修订文档中包含的修订历史记录。

11.3 社区资源

下列链接提供到 TI 社区资源的连接。链接的内容由各个分销商“按照原样”提供。这些内容并不构成 TI 技术规范，并且不一定反映 TI 的观点；请参阅 TI 的 [《使用条款》](#)。

TI E2E™ 在线社区 *TI 的工程师对工程师 (E2E) 社区*。此社区的创建目的在于促进工程师之间的协作。在 e2e.ti.com 中，您可以咨询问题、分享知识、拓展思路并与同行工程师一道帮助解决问题。

设计支持 *TI 参考设计支持* 可帮助您快速查找有帮助的 E2E 论坛、设计支持工具以及技术支持的联系信息。

11.4 商标

E2E is a trademark of Texas Instruments.

All other trademarks are the property of their respective owners.

11.5 静电放电警告



ESD 可能会损坏该集成电路。德州仪器 (TI) 建议通过适当的预防措施处理所有集成电路。如果不遵守正确的处理措施和安装程序，可能会损坏集成电路。

ESD 的损坏小至导致微小的性能降级，大至整个器件故障。精密的集成电路可能更容易受到损坏，这是因为非常细微的参数更改都可能会导致器件与其发布的规格不相符。

11.6 术语表

SLYZ022 — *TI 术语表*。

这份术语表列出并解释术语、缩写和定义。

12 机械、封装和可订购信息

以下页面包含机械、封装和可订购信息。这些信息是指定器件的最新可用数据。数据如有变更，恕不另行通知，且不会对此文档进行修订。如需获取此产品说明书的浏览器版本，请查看左侧的导航栏。

重要声明和免责声明

TI 均以“原样”提供技术性数据（包括数据表）、设计资源（包括参考设计）、应用或其他设计建议、网络工具、安全信息和其他资源，不保证其中不含任何瑕疵，且不做任何明示或暗示的担保，包括但不限于对适销性、适合某特定用途或不侵犯任何第三方知识产权的暗示担保。

所述资源可供专业开发人员应用TI 产品进行设计使用。您将对以下行为独自承担全部责任：(1) 针对您的应用选择合适的TI 产品；(2) 设计、验证并测试您的应用；(3) 确保您的应用满足相应标准以及任何其他安全、安保或其他要求。所述资源如有变更，恕不另行通知。TI 对您使用所述资源的授权仅限于开发资源所涉及TI 产品的相关应用。除此之外不得复制或展示所述资源，也不提供其它TI 或任何第三方的知识产权授权许可。如因使用所述资源而产生任何索赔、赔偿、成本、损失及债务等，TI 对此概不负责，并且您须赔偿由此对TI 及其代表造成的损害。

TI 所提供产品均受TI 的销售条款 (<http://www.ti.com.cn/zh-cn/legal/termsofsale.html>) 以及ti.com.cn上或随附TI产品提供的其他可适用条款的约束。TI提供所述资源并不扩展或以其他方式更改TI 针对TI 产品所发布的可适用的担保范围或担保免责声明。

邮寄地址：上海市浦东新区世纪大道 1568 号中建大厦 32 楼，邮政编码：200122
Copyright © 2018 德州仪器半导体技术（上海）有限公司

PACKAGING INFORMATION

Orderable Device	Status (1)	Package Type	Package Drawing	Pins	Package Qty	Eco Plan (2)	Lead finish/ Ball material (6)	MSL Peak Temp (3)	Op Temp (°C)	Device Marking (4/5)	Samples
TUSB1044IRNQR	ACTIVE	WQFN	RNQ	40	3000	RoHS & Green	NIPDAU	Level-2-260C-1 YEAR	-40 to 85	TUSB44	Samples
TUSB1044IRNQT	ACTIVE	WQFN	RNQ	40	250	RoHS & Green	NIPDAU	Level-2-260C-1 YEAR	-40 to 85	TUSB44	Samples
TUSB1044RNQR	ACTIVE	WQFN	RNQ	40	3000	RoHS & Green	NIPDAU	Level-2-260C-1 YEAR	0 to 70	TUSB44	Samples
TUSB1044RNQT	ACTIVE	WQFN	RNQ	40	250	RoHS & Green	NIPDAU	Level-2-260C-1 YEAR	0 to 70	TUSB44	Samples

(1) The marketing status values are defined as follows:

ACTIVE: Product device recommended for new designs.

LIFEBUY: TI has announced that the device will be discontinued, and a lifetime-buy period is in effect.

NRND: Not recommended for new designs. Device is in production to support existing customers, but TI does not recommend using this part in a new design.

PREVIEW: Device has been announced but is not in production. Samples may or may not be available.

OBSELETE: TI has discontinued the production of the device.

(2) **RoHS:** TI defines "RoHS" to mean semiconductor products that are compliant with the current EU RoHS requirements for all 10 RoHS substances, including the requirement that RoHS substance do not exceed 0.1% by weight in homogeneous materials. Where designed to be soldered at high temperatures, "RoHS" products are suitable for use in specified lead-free processes. TI may reference these types of products as "Pb-Free".

RoHS Exempt: TI defines "RoHS Exempt" to mean products that contain lead but are compliant with EU RoHS pursuant to a specific EU RoHS exemption.

Green: TI defines "Green" to mean the content of Chlorine (Cl) and Bromine (Br) based flame retardants meet JS709B low halogen requirements of <=1000ppm threshold. Antimony trioxide based flame retardants must also meet the <=1000ppm threshold requirement.

(3) **MSL, Peak Temp.** - The Moisture Sensitivity Level rating according to the JEDEC industry standard classifications, and peak solder temperature.

(4) There may be additional marking, which relates to the logo, the lot trace code information, or the environmental category on the device.

(5) Multiple Device Markings will be inside parentheses. Only one Device Marking contained in parentheses and separated by a "-" will appear on a device. If a line is indented then it is a continuation of the previous line and the two combined represent the entire Device Marking for that device.

(6) **Lead finish/Ball material** - Orderable Devices may have multiple material finish options. Finish options are separated by a vertical ruled line. Lead finish/Ball material values may wrap to two lines if the finish value exceeds the maximum column width.

Important Information and Disclaimer:The information provided on this page represents TI's knowledge and belief as of the date that it is provided. TI bases its knowledge and belief on information provided by third parties, and makes no representation or warranty as to the accuracy of such information. Efforts are underway to better integrate information from third parties. TI has taken and

continues to take reasonable steps to provide representative and accurate information but may not have conducted destructive testing or chemical analysis on incoming materials and chemicals. TI and TI suppliers consider certain information to be proprietary, and thus CAS numbers and other limited information may not be available for release.

In no event shall TI's liability arising out of such information exceed the total purchase price of the TI part(s) at issue in this document sold by TI to Customer on an annual basis.

TAPE AND REEL INFORMATION

QUADRANT ASSIGNMENTS FOR PIN 1 ORIENTATION IN TAPE

*All dimensions are nominal

Device	Package Type	Package Drawing	Pins	SPQ	Reel Diameter (mm)	Reel Width W1 (mm)	A0 (mm)	B0 (mm)	K0 (mm)	P1 (mm)	W (mm)	Pin1 Quadrant
TUSB1044IRNQR	WQFN	RNQ	40	3000	330.0	12.4	4.3	6.3	1.1	8.0	12.0	Q2
TUSB1044IRNQT	WQFN	RNQ	40	250	180.0	12.4	4.3	6.3	1.1	8.0	12.0	Q2
TUSB1044RNQR	WQFN	RNQ	40	3000	330.0	12.4	4.3	6.3	1.1	8.0	12.0	Q2
TUSB1044RNQT	WQFN	RNQ	40	250	180.0	12.4	4.3	6.3	1.1	8.0	12.0	Q2

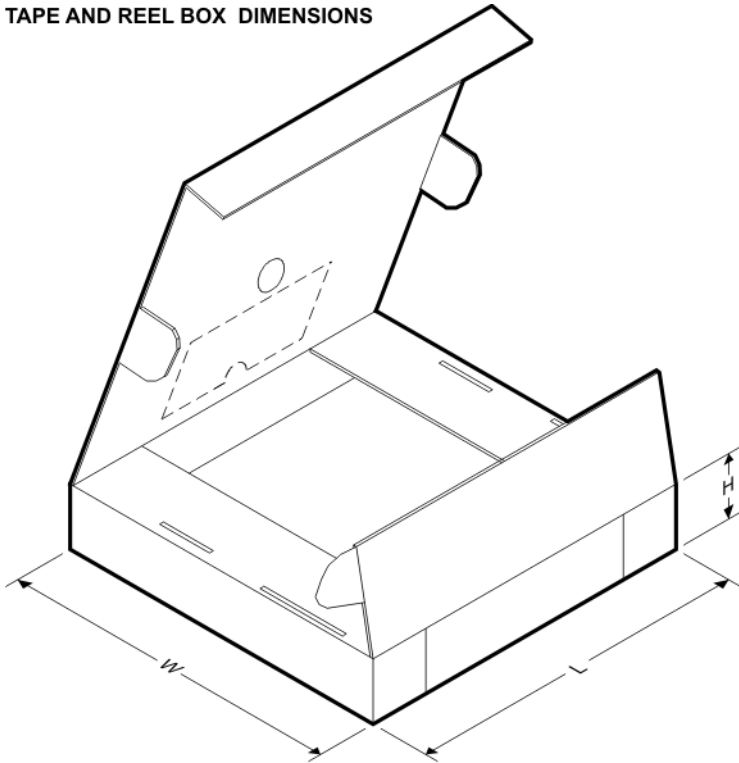
TAPE AND REEL BOX DIMENSIONS

*All dimensions are nominal

Device	Package Type	Package Drawing	Pins	SPQ	Length (mm)	Width (mm)	Height (mm)
TUSB1044IRNQR	WQFN	RNQ	40	3000	367.0	367.0	35.0
TUSB1044IRNQT	WQFN	RNQ	40	250	210.0	185.0	35.0
TUSB1044RNQR	WQFN	RNQ	40	3000	367.0	367.0	35.0
TUSB1044RNQT	WQFN	RNQ	40	250	210.0	185.0	35.0

RNQ0040A

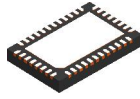

PACKAGE OUTLINE

WQFN - 0.8 mm max height

PLASTIC QUAD FLATPACK - NO LEAD

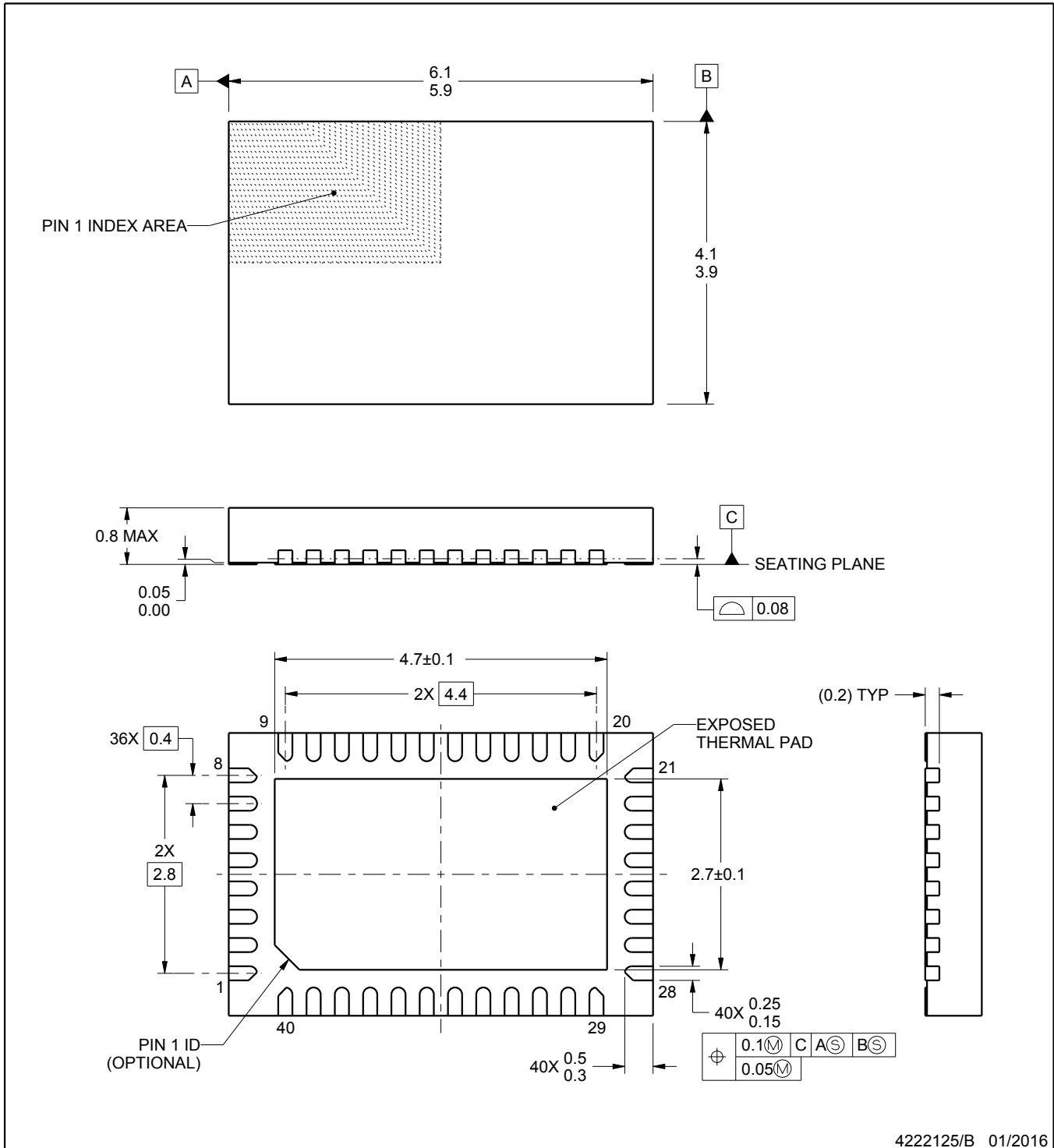

4222125/B 01/2016

NOTES:

1. All linear dimensions are in millimeters. Any dimensions in parenthesis are for reference only. Dimensioning and tolerancing per ASME Y14.5M.
2. This drawing is subject to change without notice.
3. The package thermal pad must be soldered to the printed circuit board for thermal and mechanical performance.

EXAMPLE STENCIL DESIGN

RNQ0040A

WQFN - 0.8 mm max height

PLASTIC QUAD FLATPACK - NO LEAD

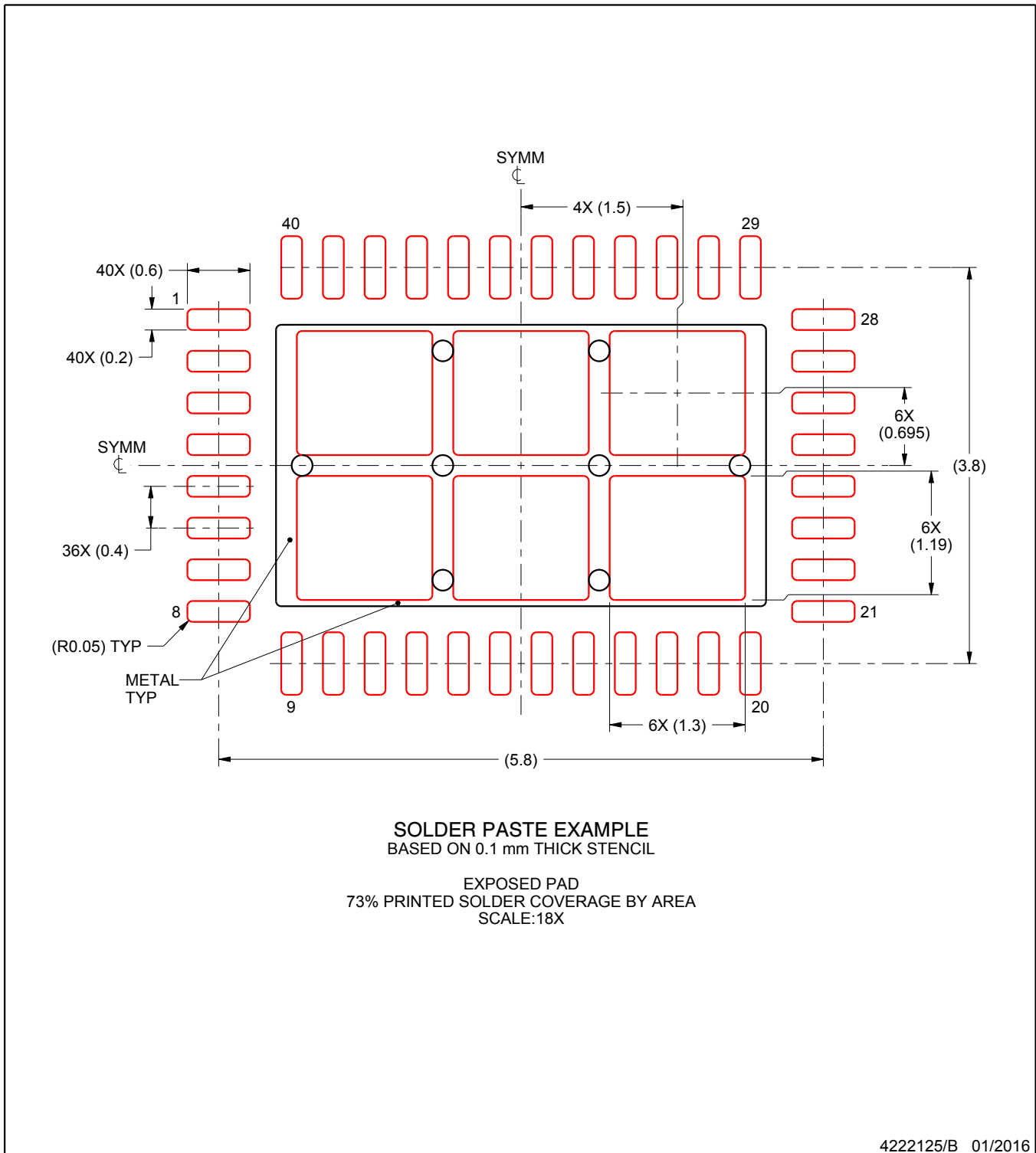

NOTES: (continued)

5. Laser cutting apertures with trapezoidal walls and rounded corners may offer better paste release. IPC-7525 may have alternate design recommendations.

重要声明和免责声明

TI 均以“原样”提供技术性及其可靠性数据（包括数据表）、设计资源（包括参考设计）、应用或其他设计建议、网络工具、安全信息和其他资源，不保证其中不含任何瑕疵，且不做任何明示或暗示的担保，包括但不限于对适销性、适合某特定用途或不侵犯任何第三方知识产权的暗示担保。

所述资源可供专业开发人员应用TI 产品进行设计使用。您将对以下行为独自承担全部责任：(1) 针对您的应用选择合适的TI 产品；(2) 设计、验证并测试您的应用；(3) 确保您的应用满足相应标准以及任何其他安全、安保或其他要求。所述资源如有变更，恕不另行通知。TI 对您使用所述资源的授权仅限于开发资源所涉及TI 产品的相关应用。除此之外不得复制或展示所述资源，也不提供其它TI 或任何第三方的知识产权授权许可。如因使用所述资源而产生任何索赔、赔偿、成本、损失及债务等，TI 对此概不负责，并且您须赔偿由此对TI 及其代表造成的损害。

TI 所提供产品均受TI 的销售条款 (<http://www.ti.com.cn/zh-cn/legal/termsofsale.html>) 以及ti.com.cn 上或随附TI 产品提供的其他可适用条款的约束。TI 提供所述资源并不扩展或以其他方式更改TI 针对TI 产品所发布的可适用的担保范围或担保免责声明。

邮寄地址：上海市浦东新区世纪大道 1568 号中建大厦 32 楼，邮政编码：200122

Copyright © 2020 德州仪器半导体技术（上海）有限公司