

LMC6484 CMOS, Quad, Rail-to-Rail Input and Output, Operational Amplifier

1 Features

- Rail-to-rail input common-mode voltage range (specified over temperature)
- Rail-to-rail output swing (within 20 mV of supply rail, 100-k Ω load)
- Specified 3-V, 5-V and 15-V performance
- Excellent CMRR and PSRR: 82 dB
- Ultra-low input current: 20 fA
- High voltage gain ($R_L = 500$ k Ω): 130 dB
- Specified for 2-k Ω and 600- Ω loads

2 Applications

- [Data acquisition \(DAQ\)](#)
- [Currency counter](#)
- [Oscilloscope \(DSO\)](#)
- [Intra-DC interconnect \(METRO\)](#)
- [Macro remote radio unit \(RRU\)](#)
- [Multiparameter patient monitor](#)
- [Merchant telecom rectifiers](#)
- [Train control and management](#)
- [Process analytics \(pH, gas, concentration, force, and humidity\)](#)
- [Three phase UPS](#)
- Improved replacement for TLC274, TLC279

3 Description

The LMC6484 device provides a common-mode range that extends to both supply rails. This rail-to-rail performance combined with excellent accuracy, due to a high CMRR, makes this device unique among rail-to-rail input amplifiers.

The LMC6484 is an excellent choice for systems, such as data acquisition, that require a large input signal range. The device is also an excellent upgrade for circuits using limited common-mode range amplifiers, such as the [TLC274](#) and [TLC279](#).

Maximum dynamic signal range is maintained in low voltage and single-supply systems by the rail-to-rail output swing of the LMC6484. The rail-to-rail output swing of the LMC6484 is specified for loads down to 600 Ω .

Specified low voltage characteristics and low power dissipation make the LMC6484 an excellent choice for battery-operated systems.

See the [LMC6482](#) for a dual CMOS operational amplifier with these same features.

Device Information⁽¹⁾

PART NUMBER	PACKAGE	BODY SIZE (NOM)
LMC6484	SOIC (14)	8.65 mm x 3.91 mm
	PDIP (14)	19.177 mm x 6.35 mm

(1) For all available packages, see the package option addendum at the end of the data sheet.

Single-Ended Unity Gain Buffer

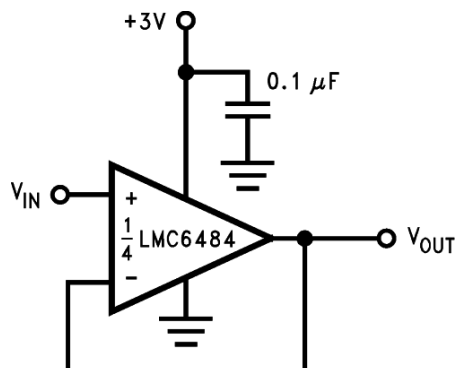

Table of Contents

1 Features	1	7 Detailed Description	23
2 Applications	1	7.1 Overview	23
3 Description	1	7.2 Functional Block Diagram	23
4 Revision History	2	7.3 Feature Description	23
5 Pin Configuration and Functions	3	7.4 Device Functional Modes	24
6 Specifications	4	8 Application and Implementation	25
6.1 Absolute Maximum Ratings	4	8.1 Application Information	25
6.2 ESD Ratings	4	8.2 Typical Application	25
6.3 Recommended Operating Conditions	4	8.3 System Examples	31
6.4 Thermal Information	4	9 Power Supply Recommendations	36
6.5 DC Electrical Characteristics for LMC6484AI	5	10 Layout	36
6.6 DC Electrical Characteristics for LMC6484I	7	10.1 Layout Guidelines	36
6.7 DC Electrical Characteristics for LMC6484M	9	10.2 Layout Example	37
6.8 DC Electrical Characteristics for LMC6484AI	11	11 Device and Documentation Support	38
6.9 DC Electrical Characteristics for LMC6484I	11	11.1 Device Support	38
6.10 DC Electrical Characteristics for LMC6484M	12	11.2 Documentation Support	38
6.11 AC Electrical Characteristics for LMC6484A	13	11.3 Support Resources	38
6.12 AC Electrical Characteristics for LMC6484I	13	11.4 Trademarks	38
6.13 AC Electrical Characteristics for LMC6484M	14	11.5 Electrostatic Discharge Caution	38
6.14 AC Electrical Characteristics: $V^+ = 3\text{ V}$, $V^- = 0\text{ V}$..	14	11.6 Glossary	38
6.15 Typical Characteristics	15	12 Mechanical, Packaging, and Orderable Information	38

4 Revision History

NOTE: Page numbers for previous revisions may differ from page numbers in the current version.

Changes from Revision C (September 2015) to Revision D Page

• Deleted old note 3 from <i>DC Electrical Characteristics for LMC6484AI</i> table	5
• Deleted old note 3 from <i>DC Electrical Characteristics for LMC6484I</i> table	7
• Deleted old note 3 from <i>DC Electrical Characteristics for LMC6484M</i> table	9

Changes from Revision B (August 2000) to Revision C Page

• Added <i>ESD Ratings</i> table, <i>Feature Description</i> section, <i>Device Functional Modes</i> , <i>Application and Implementation</i> section, <i>Power Supply Recommendations</i> section, <i>Layout</i> section, <i>Device and Documentation Support</i> section, and <i>Mechanical, Packaging, and Orderable Information</i> section.	1
--	----------

5 Pin Configuration and Functions

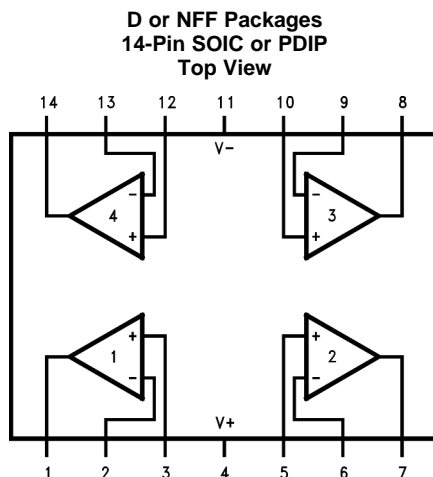

Pin Functions

PIN		TYPE	DESCRIPTION
NO.	NAME		
1	OUTPUT1	O	Output for Amplifier 1
2	INVERTING INPUT1	I	Inverting input for Amplifier 1
3	NONINVERTING INPUT1	I	Noninverting input for Amplifier 1
4	V+	P	Positive voltage supply pin
5	NONINVERTING INPUT2	I	Noninverting input for Amplifier 2
6	INVERTING INPUT2	I	Inverting input for Amplifier 2
7	OUTPUT2	O	Output for Amplifier 2
8	OUTPUT3	O	Output for Amplifier 3
9	INVERTING INPUT3	I	Inverting input for Amplifier 3
10	NONINVERTING INPUT3	I	Noninverting input for Amplifier 3
11	V-	P	Negative supply voltage pin
12	NONINVERTING INPUT4	I	Noninverting input for Amplifier 4
13	INVERTING INPUT4	I	Inverting input for Amplifier 4
14	OUTPUT4	O	Output for Amplifier 5

6 Specifications

6.1 Absolute Maximum Ratings

See ⁽¹⁾⁽²⁾

		MIN	MAX	UNIT
	Differential input voltage	±Supply Voltage		
	Voltage at input/output pin	(V ⁻) - 0.3	(V ⁺) + 0.3	V
	Supply voltage (V ⁺ - V ⁻)		16	V
	Current at input pin ⁽³⁾		±5	mA
	Current at output pin ⁽⁴⁾⁽⁵⁾		±30	mA
	Current at power supply pin		40	mA
T _J	Junction temperature ⁽⁶⁾		150	°C
T _{stg}	Storage temperature, T _{stg}	-65	150	°C

- (1) Stresses beyond those listed under *Absolute Maximum Ratings* may cause permanent damage to the device. These are stress ratings only, which do not imply functional operation of the device at these or any other conditions beyond those indicated under *Recommended Operating Conditions*. Exposure to absolute-maximum-rated conditions for extended periods may affect device reliability.
- (2) If Military/Aerospace specified devices are required, contact the Texas Instruments Sales Office/Distributors for availability and specifications.
- (3) Limiting input pin current is only necessary for input voltages that exceed absolute maximum input voltage ratings.
- (4) Applies to both single supply and split-supply operation. Continuous short circuit operation at elevated ambient temperature can result in exceeding the maximum allowed junction temperature of 150°C. Output currents in excess of ±30 mA over long term may adversely affect reliability.
- (5) Do not short circuit output to V⁺, when V⁺ is greater than 13 V or reliability will be adversely affected.
- (6) The maximum power dissipation is a function of T_{J(max)}, R_{θJA}, and T_A. The maximum allowable power dissipation at any ambient temperature is P_D = (T_{J(max)} - T_A)/R_{θJA}. All numbers apply for packages soldered directly into a PC board.

6.2 ESD Ratings

			VALUE	UNIT
V _(ESD)	Electrostatic discharge	Human body model (HBM), per ANSI/ESDA/JEDEC JS-001 ⁽¹⁾⁽²⁾	±2000	V

- (1) JEDEC document JEP155 states that 500-V HBM allows safe manufacturing with a standard ESD control process. Manufacturing with less than 500-V HBM is possible with the necessary precautions.
- (2) Human body model, 1.5-kΩ resistor in series with 100 pF. All pins rated per method 3015.6 of MIL-STD-883. This is a class 2 device rating.

6.3 Recommended Operating Conditions

over operating free-air temperature range (unless otherwise noted)

		MIN	MAX	UNIT	
V+	Supply voltage	3	15.5	V	
T _J	Junction temperature	LMC6484AM	-55	125	°C
		LMC6484AI, LMC6484I	-40	85	°C

6.4 Thermal Information

THERMAL METRIC ⁽¹⁾		LMC6484		UNIT
		D (SOIC)	NFF (PDIP)	
		14 PINS	14 PINS	
R _{θJA}	Junction-to-ambient thermal resistance	110	70	°C/W

- (1) For more information about traditional and new thermal metrics, see the [Semiconductor and IC Package Thermal Metrics application report](#).

6.5 DC Electrical Characteristics for LMC6484AI

unless otherwise specified, all limits specified for $T_J = 25^\circ\text{C}$, $V^+ = 5\text{ V}$, $V^- = 0\text{ V}$, $V_{\text{CM}} = V_O = V^+/2$, and $R_L > 1\text{ M}$

PARAMETER		TEST CONDITIONS		MIN ⁽¹⁾	TYP ⁽²⁾	MAX ⁽¹⁾	UNIT
V_{OS}	Input offset voltage				0.11	0.75	mV
		At the temperature extremes				1.35	
TCV_{OS}	Input offset voltage average drift				1		$\mu\text{V}/^\circ\text{C}$
I_{B}	Input current				0.02		μA
		At the temperature extremes				4	
I_{OS}	Input offset current				0.01		μA
		At the temperature extremes				2	
C_{IN}	Common-mode input capacitance				3		pF
R_{IN}	Input resistance				>10		Tera Ω
CMRR	Common-mode rejection ratio	$0\text{ V} \leq V_{\text{CM}} \leq 15\text{ V}$ $V^+ = 15\text{ V}$		70	82		dB
			At the temperature extremes	67			
		$0\text{ V} \leq V_{\text{CM}} \leq 5\text{ V}$ $V^+ = 5\text{ V}$		70	82		dB
			At the temperature extremes	67			
+PSRR	Positive power supply rejection ratio	$5\text{ V} \leq V^+ \leq 15\text{ V}$ $V^- = 0\text{ V}$ $V_O = 2.5\text{ V}$		70	82		dB
			At the temperature extremes	67			
-PSRR	Negative power supply rejection ratio	$-5\text{ V} \leq V^- \leq -15\text{ V}$ $V^+ = 0\text{ V}$ $V_O = -2.5\text{ V}$		70	82		dB
			At the temperature extremes	67			
V_{CM}	Input common-mode voltage range	$V^+ = 5\text{ V}$ and 15 V For $\text{CMRR} \geq 50\text{ dB}$			$V^- - 0.3$	-0.25	V
			At the temperature extremes			0	
				$V^+ + 0.25$	$V^+ + 0.3$		V
			At the temperature extremes	V^+			
A_{V}	Large signal voltage gain	$R_L = 2\text{ k}\Omega^{(3)}$	Sourcing		140	666	V/mV
				At the temperature extremes	84		
			Sinking		35	75	V/mV
				At the temperature extremes	20		
		$R_L = 600\ \Omega^{(3)}$	Sourcing		80	300	V/mV
				At the temperature extremes	48		
			Sinking		20	35	V/mV
				At the temperature extremes	13		

(1) All limits are specified by testing or statistical analysis.

(2) Typical values represent the most likely parametric normal.

(3) $V^+ = 15\text{ V}$, $V_{\text{CM}} = 7.5\text{ V}$ and R_L connected to 7.5 V . For sourcing tests, $7.5\text{ V} \leq V_O \leq 11.5\text{ V}$. For sinking tests, $3.5\text{ V} \leq V_O \leq 7.5\text{ V}$.

DC Electrical Characteristics for LMC6484AI (continued)

unless otherwise specified, all limits specified for $T_J = 25^\circ\text{C}$, $V^+ = 5\text{ V}$, $V^- = 0\text{ V}$, $V_{CM} = V_O = V^+/2$, and $R_L > 1\text{ M}$

PARAMETER		TEST CONDITIONS		MIN ⁽¹⁾	TYP ⁽²⁾	MAX ⁽¹⁾	UNIT		
V_O	Output swing	$V^+ = 5\text{ V}$ $R_L = 2\text{ k}\Omega$ to $V^+/2$		4.8	4.9		V		
			At the temperature extremes	4.7					
						0.1	0.18	V	
			At the temperature extremes				0.24		
			$V^+ = 5\text{ V}$ $R_L = 600\ \Omega$ to $V^+/2$		4.5	4.7		V	
				At the temperature extremes	4.24				
						0.3	0.5	V	
		At the temperature extremes					0.65		
		$V^+ = 15\text{ V}$ $R_L = 2\text{ k}\Omega$ to $V^+/2$			14.4	14.7		V	
				At the temperature extremes	14.2				
						0.16	0.32	V	
			At the temperature extremes				0.45		
$V^+ = 15\text{ V}$ $R_L = 600\ \Omega$ to $V^+/2$			13.4	14.1		V			
	At the temperature extremes		13						
				0.5	1	V			
	At the temperature extremes				1.3				
	I_{SC}	Output short circuit current $V^+ = 5\text{ V}$	Sourcing, $V_O = 0\text{ V}$		16	20	mA		
				At the temperature extremes	12				
Sinking, $V_O = 5\text{ V}$				11	15	mA			
			At the temperature extremes	9.5					
I_{SC}			Output short circuit current $V^+ = 15\text{ V}$	Sourcing, $V_O = 0\text{ V}$		28	30	mA	
					At the temperature extremes	22			
	Sinking, $V_O = 12\text{ V}^{(4)}$			30	30	mA			
		At the temperature extremes		24					
	I_S	Supply current		All four amplifiers $V^+ = +5\text{ V}$, $V_O = V^+/2$			2	2.8	mA
					At the temperature extremes				
All four amplifiers $V^+ = +15\text{ V}$, $V_O = V^+/2$						2.6	3	mA	
			At the temperature extremes				3.8		

(4) When V^+ is greater than 13 V, do not short circuit output to V^+ or reliability will be adversely affected.

6.6 DC Electrical Characteristics for LMC6484I

unless otherwise specified, all limits specified for $T_J = 25^\circ\text{C}$, $V^+ = 5\text{ V}$, $V^- = 0\text{ V}$, $V_{\text{CM}} = V_O = V^+/2$, and $R_L > 1\text{ M}$

PARAMETER		TEST CONDITIONS		MIN ⁽¹⁾	TYP ⁽²⁾	MAX ⁽¹⁾	UNIT
V_{OS}	Input offset voltage				0.11	3	mV
		At the temperature extremes				3.7	
TCV_{OS}	Input offset voltage average drift				1		$\mu\text{V}/^\circ\text{C}$
I_{B}	Input current				0.02		pA
		At the temperature extremes				4	
I_{OS}	Input offset current				0.01		pA
		At the temperature extremes				2	
C_{IN}	Common-mode input capacitance				3		pF
R_{IN}	Input resistance				>10		Tera Ω
CMRR	Common-mode rejection ratio	$0\text{ V} \leq V_{\text{CM}} \leq 15\text{ V}$ $V^+ = 15\text{ V}$		65	82		dB
			At the temperature extremes	62			
		$0\text{ V} \leq V_{\text{CM}} \leq 5\text{ V}$ $V^+ = 5\text{ V}$		65	82		dB
			At the temperature extremes	60			
+PSRR	Positive power supply rejection ratio	$5\text{ V} \leq V^+ \leq 15\text{ V}$ $V^- = 0\text{ V}$, $V_O = 2.5\text{ V}$		65	82		dB
			At the temperature extremes	62			
-PSRR	Negative power supply rejection ratio	$-5\text{ V} \leq V^- \leq -15\text{ V}$ $V^+ = 0\text{ V}$, $V_O = -2.5\text{ V}$		65	82		dB
			At the temperature extremes	62			
V_{CM}	Input common-mode voltage range	$V^+ = 5\text{ V}$ and 15 V For CMRR $\geq 50\text{ dB}$			$V^- - 0.3$	-0.25	V
			At the temperature extremes			0	
				$V^+ + 0.25$	$V^+ + 0.3$		V
			At the temperature extremes	V^+			
A_{V}	Large signal voltage gain	$R_L = 2\text{ k}\Omega^{(3)}$	Sourcing		120	666	V/mV
				At the temperature extremes	72		
			Sinking		35	75	
				At the temperature extremes	20		
		$R_L = 600\ \Omega^{(3)}$	Sourcing		50	300	
				At the temperature extremes	30		
			Sinking		15	35	
				At the temperature extremes	10		

(1) All limits are specified by testing or statistical analysis.

(2) Typical values represent the most likely parametric normal.

(3) $V^+ = 15\text{ V}$, $V_{\text{CM}} = 7.5\text{ V}$ and R_L connected to 7.5 V . For sourcing tests, $7.5\text{ V} \leq V_O \leq 11.5\text{ V}$. For sinking tests, $3.5\text{ V} \leq V_O \leq 7.5\text{ V}$.

DC Electrical Characteristics for LMC6484I (continued)

unless otherwise specified, all limits specified for $T_J = 25^\circ\text{C}$, $V^+ = 5\text{ V}$, $V^- = 0\text{ V}$, $V_{CM} = V_O = V^+/2$, and $R_L > 1\text{ M}$

PARAMETER		TEST CONDITIONS		MIN ⁽¹⁾	TYP ⁽²⁾	MAX ⁽¹⁾	UNIT	
V_O	Output swing	$V^+ = 5\text{ V}$ $R_L = 2\text{ k}\Omega$ to $V^+/2$		4.8	4.9		V	
			At the temperature extremes	4.7				
		$V^+ = 5\text{ V}$ $R_L = 600\ \Omega$ to $V^+/2$			0.1	0.18		V
			At the temperature extremes			0.24		
		$V^+ = 5\text{ V}$ $R_L = 600\ \Omega$ to $V^+/2$		4.5	4.7			V
			At the temperature extremes	4.24				
		$V^+ = 5\text{ V}$ $R_L = 600\ \Omega$ to $V^+/2$			0.3	0.5		V
			At the temperature extremes			0.65		
		$V^+ = 15\text{ V}$ $R_L = 2\text{ k}\Omega$ to $V^+/2$		14.4	14.7			V
			At the temperature extremes	14.2				
		$V^+ = 15\text{ V}$ $R_L = 2\text{ k}\Omega$ to $V^+/2$			0.16	0.32		V
			At the temperature extremes			0.45		
$V^+ = 15\text{ V}$ $R_L = 600\ \Omega$ to $V^+/2$		13.4	14.1			V		
	At the temperature extremes	13						
$V^+ = 15\text{ V}$ $R_L = 600\ \Omega$ to $V^+/2$			0.5	1		V		
	At the temperature extremes			1.3				
I_{SC}	Output short circuit current $V^+ = 5\text{ V}$	Sourcing, $V_O = 0\text{ V}$		16	20		mA	
			At the temperature extremes	12				
I_{SC}	Output short circuit current $V^+ = 5\text{ V}$	Sinking, $V_O = 5\text{ V}$		11	15		mA	
			At the temperature extremes	9.5				
I_{SC}	Output short circuit current $V^+ = 15\text{ V}$	Sourcing, $V_O = 0\text{ V}$		28	30		mA	
			At the temperature extremes	22				
I_{SC}	Output short circuit current $V^+ = 15\text{ V}$	Sinking, $V_O = 12\text{ V}^{(4)}$		30	30		mA	
			At the temperature extremes	24				
I_S	Supply current	All four amplifiers $V^+ = +5\text{ V}$ $V_O = V^+/2$			2	2.8	mA	
			At the temperature extremes					3.6
I_S	Supply current	All four amplifiers $V^+ = +15\text{ V}$ $V_O = V^+/2$			2.6	3	mA	
			At the temperature extremes					3.8

(4) When V^+ is greater than 13 V, do not short circuit output to V^+ or reliability will be adversely affected.

6.7 DC Electrical Characteristics for LMC6484M

unless otherwise specified, all limits specified for $T_J = 25^\circ\text{C}$, $V^+ = 5\text{ V}$, $V^- = 0\text{ V}$, $V_{\text{CM}} = V_O = V^+/2$, and $R_L > 1\text{ M}$

PARAMETER		TEST CONDITIONS		MIN ⁽¹⁾	TYP ⁽²⁾	MAX ⁽¹⁾	UNIT
V_{OS}	Input offset voltage				0.11	3	mV
		At the temperature extremes				3.8	
TCV_{OS}	Input offset voltage average drift				1		$\mu\text{V}/^\circ\text{C}$
I_{B}	Input current				0.02		μA
		At the temperature extremes				100	
I_{OS}	Input offset current				0.01		μA
		At the temperature extremes				50	
C_{IN}	Common-mode input capacitance				3		pF
R_{IN}	Input resistance				>10		Tera Ω
CMRR	Common-mode rejection ratio	$0\text{ V} \leq V_{\text{CM}} \leq 15\text{ V}$ $V^+ = 15\text{ V}$		65	82		dB
			At the temperature extremes	60			
		$0\text{ V} \leq V_{\text{CM}} \leq 5\text{ V}$ $V^+ = 5\text{ V}$		65	8		dB
			At the temperature extremes	60			
+PSRR	Positive power supply rejection ratio	$5\text{ V} \leq V^+ \leq 15\text{ V}$ $V^- = 0\text{ V}$, $V_O = 2.5\text{ V}$		65	82		dB
			At the temperature extremes	60			
-PSRR	Negative power supply rejection ratio	$-5\text{ V} \leq V^- \leq -15\text{ V}$ $V^+ = 0\text{ V}$ $V_O = -2.5\text{ V}$		65	82		dB
			At the temperature extremes	60			
V_{CM}	Input common-mode voltage range	$V^+ = 5\text{ V}$ and 15 V For CMRR $\geq 50\text{ dB}$			$V^- - 0.3$	-0.25	V
			At the temperature extremes			0	
				$V^+ + 0.25$	$V^+ + 0.3$		V
			At the temperature extremes	V^+			
A_{V}	Large signal voltage gain	$R_L = 2\text{ k}\Omega^{(3)}$	Sourcing		120	666	V/mV
				At the temperature extremes	72		
			Sinking		35	75	
				At the temperature extremes	20		
		$R_L = 600\ \Omega^{(3)}$	Sourcing		50	300	
				At the temperature extremes	30		
			Sinking		15	35	
				At the temperature extremes	10		

(1) All limits are specified by testing or statistical analysis.

(2) Typical values represent the most likely parametric normal.

(3) $V^+ = 15\text{ V}$, $V_{\text{CM}} = 7.5\text{ V}$ and R_L connected to 7.5 V . For sourcing tests, $7.5\text{ V} \leq V_O \leq 11.5\text{ V}$. For sinking tests, $3.5\text{ V} \leq V_O \leq 7.5\text{ V}$.

DC Electrical Characteristics for LMC6484M (continued)

unless otherwise specified, all limits specified for $T_J = 25^\circ\text{C}$, $V^+ = 5\text{ V}$, $V^- = 0\text{ V}$, $V_{CM} = V_O = V^+/2$, and $R_L > 1\text{ M}$

PARAMETER		TEST CONDITIONS		MIN ⁽¹⁾	TYP ⁽²⁾	MAX ⁽¹⁾	UNIT	
V_O	Output swing	$V^+ = 5\text{ V}$ $R_L = 2\text{ k}\Omega$ to $V^+/2$		4.8	4.9		V	
			At the temperature extremes	4.7				
		$V^+ = 5\text{ V}$ $R_L = 600\ \Omega$ to $V^+/2$			0.1	0.18		V
			At the temperature extremes			0.24		
		$V^+ = 5\text{ V}$ $R_L = 600\ \Omega$ to $V^+/2$		4.5	4.7			V
			At the temperature extremes	4.24				
		$V^+ = 15\text{ V}$ $R_L = 2\text{ k}\Omega$ to $V^+/2$			0.3	0.5		V
			At the temperature extremes			0.65		
		$V^+ = 15\text{ V}$ $R_L = 2\text{ k}\Omega$ to $V^+/2$		14.4	14.7			V
			At the temperature extremes	14.2				
		$V^+ = 15\text{ V}$ $R_L = 2\text{ k}\Omega$ to $V^+/2$			0.16	0.32		V
			At the temperature extremes			0.45		
$V^+ = 15\text{ V}$ $R_L = 600\ \Omega$ to $V^+/2$		13.4	14.1			V		
	At the temperature extremes	13						
$V^+ = 15\text{ V}$ $R_L = 600\ \Omega$ to $V^+/2$			0.5	1		V		
	At the temperature extremes			1.3				
I_{SC}	Output short circuit current $V^+ = 5\text{ V}$	Sourcing, $V_O = 0\text{ V}$		16	20		mA	
			At the temperature extremes	10				
I_{SC}	Output short circuit current $V^+ = 5\text{ V}$	Sinking, $V_O = 5\text{ V}$		11	15		mA	
			At the temperature extremes	8				
I_{SC}	Output short circuit current $V^+ = 15\text{ V}$	Sourcing, $V_O = 0\text{ V}$		28	30		mA	
			At the temperature extremes	20				
I_{SC}	Output short circuit current $V^+ = 15\text{ V}$	Sinking, $V_O = 12\text{ V}^{(4)}$		30	30		mA	
			At the temperature extremes	22				
I_S	Supply current	All four amplifiers $V^+ = +5\text{ V}$ $V_O = V^+/2$			2	2.8	mA	
			At the temperature extremes			3.8		
I_S	Supply current	All four amplifiers $V^+ = +15\text{ V}$, $V_O = V^+/2$			2.6	3	mA	
			At the temperature extremes			4		

(4) When V^+ is greater than 13 V, do not short circuit output to V^+ or reliability will be adversely affected.

6.8 DC Electrical Characteristics for LMC6484AI

unless otherwise specified, all limits specified for $T_J = 25^\circ\text{C}$, $V^+ = 3\text{ V}$, $V^- = 0\text{ V}$, $V_{\text{CM}} = V_O = V^+/2$, and $R_L > 1\text{ M}$

PARAMETER		TEST CONDITIONS	MIN ⁽¹⁾	TYP ⁽²⁾	MAX ⁽¹⁾	UNIT	
V_{OS}	Input offset voltage			0.9	2	mV	
		At the temperature extremes			2.7		
TCV_{OS}	Input offset voltage average drift			2		$\mu\text{V}/^\circ\text{C}$	
I_B	Input bias current			0.02		pA	
I_{OS}	Input offset current			0.01		pA	
CMRR	Common-mode rejection ratio	$0\text{ V} \leq V_{\text{CM}} \leq 3\text{ V}$	64	74		dB	
PSRR	Power supply rejection ratio	$3\text{ V} \leq V^+ \leq 15\text{ V}$, $V^- = 0\text{ V}$	68	80		dB	
V_{CM}	Input common-mode voltage range	For CMRR $\geq 50\text{ dB}$		$V^- - 0.25$	0	V	
				V^+	$V^+ + 0.25$	V	
V_O	Output swing	$R_L = 2\text{ k}\Omega$ to $V^+/2$		2.8		V	
				0.2		V	
		$R_L = 600\ \Omega$ to $V^+/2$		2.5	2.7		V
				0.37	0.6		V
I_S	Supply current	All four amplifiers		1.65	2.5	mA	
			At the temperature extremes				3

- (1) All limits are specified by testing or statistical analysis.
 (2) Typical values represent the most likely parametric normal.

6.9 DC Electrical Characteristics for LMC6484I

unless otherwise specified, all limits specified for $T_J = 25^\circ\text{C}$, $V^+ = 3\text{ V}$, $V^- = 0\text{ V}$, $V_{\text{CM}} = V_O = V^+/2$, and $R_L > 1\text{ M}$

PARAMETER		TEST CONDITIONS	MIN ⁽¹⁾	TYP ⁽²⁾	MAX ⁽¹⁾	UNIT	
V_{OS}	Input offset voltage			0.9	3	mV	
		At the temperature extremes			3.7		
TCV_{OS}	Input offset voltage average drift			2		$\mu\text{V}/^\circ\text{C}$	
I_B	Input bias current			0.02		pA	
I_{OS}	Input offset current			0.01		pA	
CMRR	Common-mode rejection ratio	$0\text{ V} \leq V_{\text{CM}} \leq 3\text{ V}$	60	74		dB	
PSRR	Power supply rejection ratio	$3\text{ V} \leq V^+ \leq 15\text{ V}$, $V^- = 0\text{ V}$	60	80		dB	
V_{CM}	Input common-mode voltage range	For CMRR $\geq 50\text{ dB}$		$V^- - 0.25$	0	V	
				V^+	$V^+ + 0.25$	V	
V_O	Output swing	$R_L = 2\text{ k}\Omega$ to $V^+/2$		2.8		V	
				0.2		V	
		$R_L = 600\ \Omega$ to $V^+/2$		2.5	2.7		V
				0.37	0.6		V
I_S	Supply current	All four amplifiers		1.65	2.5	mA	
			At the temperature extremes				3

- (1) All limits are specified by testing or statistical analysis.
 (2) Typical values represent the most likely parametric normal.

6.10 DC Electrical Characteristics for LMC6484M

unless otherwise specified, all limits specified for $T_J = 25^\circ\text{C}$, $V^+ = 3\text{ V}$, $V^- = 0\text{ V}$, $V_{\text{CM}} = V_O = V^+/2$, and $R_L > 1\text{ M}$

PARAMETER		TEST CONDITIONS		MIN ⁽¹⁾	TYP ⁽²⁾	MAX ⁽¹⁾	UNIT
V_{OS}	Input offset voltage				0.9	3	mV
		At the temperature extremes				3.8	
TCV_{OS}	Input offset voltage average drift				2		$\mu\text{V}/^\circ\text{C}$
I_B	Input bias current				0.02		pA
I_{OS}	Input offset current				0.01		pA
CMRR	Common-mode rejection ratio	$0\text{ V} \leq V_{\text{CM}} \leq 3\text{ V}$		60	74		dB
PSRR	Power supply rejection ratio	$3\text{ V} \leq V^+ \leq 15\text{ V}$, $V^- = 0\text{ V}$		60	80		dB
V_{CM}	Input common-mode voltage range	For CMRR $\geq 50\text{ dB}$			$V^- - 0.25$	0	V
					$V^+ + 0.25$		V
V_O	Output swing	$R_L = 2\text{ k}\Omega$ to $V^+/2$			2.8		V
					0.2		V
		$R_L = 600\ \Omega$ to $V^+/2$		2.5	2.7		V
					0.37	0.6	V
I_S	Supply current	All four amplifiers		1.65	2.5	mA	
			At the temperature extremes				3.2

- (1) All limits are specified by testing or statistical analysis.
 (2) Typical values represent the most likely parametric normal.

6.11 AC Electrical Characteristics for LMC6484A

unless otherwise specified, all limits specified for $T_J = 25^\circ\text{C}$, $V^+ = 5\text{ V}$, $V^- = 0\text{ V}$, $V_{\text{CM}} = V_O = V^+ / 2$, and $R_L > 1\text{ M}$

PARAMETER		TEST CONDITIONS	MIN ⁽¹⁾	TYP ⁽²⁾	MAX ⁽¹⁾	UNIT
SR	Slew rate ⁽³⁾		1	1.3		V/ μs
		At the temperature extremes	0.7			
GBW	Gain-bandwidth product	$V^+ = 15\text{ V}$		1.5		MHz
Φ_m	Phase margin			50		Deg
G_m	Gain margin			15		dB
	Amplifier-to-amplifier isolation ⁽⁴⁾			150		
e_n	Input-referred voltage noise	$f = 1\text{ kHz}$, $V_{\text{CM}} = 1\text{ V}$		37		$\text{nV}\sqrt{\text{Hz}}$
i_n	Input-referred current noise	$f = 1\text{ kHz}$		0.03		$\text{pA}\sqrt{\text{Hz}}$
THD	Total harmonic distortion	$f = 1\text{ kHz}$, $A_V = -2$, $R_L = 10\text{ k}\Omega$, $V_O = 4.1\text{ V}_{\text{PP}}$		0.01%		
		$f = 10\text{ kHz}$, $A_V = -2$, $R_L = 10\text{ k}\Omega$, $V_O = 8.5\text{ V}_{\text{PP}}$, $V^+ = 10\text{ V}$		0.01%		

(1) All limits are specified by testing or statistical analysis.

(2) Typical values represent the most likely parametric normal.

(3) $V^+ = 15\text{ V}$. Connected as voltage follower with 10-V step input. Number specified is the slower of either the positive or negative slew rates.

(4) Input referred, $V^+ = 15\text{ V}$ and $R_L = 100\text{ k}\Omega$ connected to 7.5 V. Each amplifier excited in turn with 1 kHz to produce $V_O = 12\text{ V}_{\text{PP}}$.

6.12 AC Electrical Characteristics for LMC6484I

unless otherwise specified, all limits specified for $T_J = 25^\circ\text{C}$, $V^+ = 5\text{ V}$, $V^- = 0\text{ V}$, $V_{\text{CM}} = V_O = V^+ / 2$, and $R_L > 1\text{ M}$

PARAMETER		TEST CONDITIONS	MIN ⁽¹⁾	TYP ⁽²⁾	MAX ⁽¹⁾	UNIT
SR	Slew rate ⁽³⁾		0.9	1.3		V/ μs
		At the temperature extremes	0.63			
GBW	Gain-bandwidth product	$V^+ = 15\text{ V}$		1.5		MHz
Φ_m	Phase margin			50		Deg
G_m	Gain margin			15		dB
	Amplifier-to-amplifier isolation ⁽⁴⁾			150		
e_n	Input-referred voltage noise	$f = 1\text{ kHz}$, $V_{\text{CM}} = 1\text{ V}$		37		$\text{nV}\sqrt{\text{Hz}}$
i_n	Input-referred current noise	$f = 1\text{ kHz}$		0.03		$\text{pA}\sqrt{\text{Hz}}$
THD	Total harmonic distortion	$f = 1\text{ kHz}$, $A_V = -2$, $R_L = 10\text{ k}\Omega$, $V_O = 4.1\text{ V}_{\text{PP}}$		0.01%		
		$f = 10\text{ kHz}$, $A_V = -2$, $R_L = 10\text{ k}\Omega$, $V_O = 8.5\text{ V}_{\text{PP}}$, $V^+ = 10\text{ V}$		0.01%		

(1) All limits are specified by testing or statistical analysis.

(2) Typical values represent the most likely parametric normal.

(3) $V^+ = 15\text{ V}$. Connected as Voltage Follower with 10-V step input. Number specified is the slower of either the positive or negative slew rates.

(4) Input referred, $V^+ = 15\text{ V}$ and $R_L = 100\text{ k}\Omega$ connected to 7.5 V. Each amp excited in turn with 1 kHz to produce $V_O = 12\text{ V}_{\text{PP}}$.

6.13 AC Electrical Characteristics for LMC6484M

unless otherwise specified, all limits specified for $T_J = 25^\circ\text{C}$, $V^+ = 5\text{ V}$, $V^- = 0\text{ V}$, $V_{CM} = V_O = V^+/2$, and $R_L > 1\text{ M}$

PARAMETER		TEST CONDITIONS	MIN ⁽¹⁾	TYP ⁽²⁾	MAX ⁽¹⁾	UNIT
SR	Slew rate ⁽³⁾		0.9	1.3		V/ μs
		At the temperature extremes	0.54			
GBW	Gain-bandwidth product	$V^+ = 15\text{ V}$		1.5		MHz
Φ_m	Phase margin			50		Deg
G_m	Gain margin			15		dB
	Amplifier-to-amplifier isolation ⁽⁴⁾			150		dB
e_n	Input-referred voltage noise	$f = 1\text{ kHz}$, $V_{CM} = 1\text{ V}$		37		$\text{nV}\sqrt{\text{Hz}}$
i_n	Input-referred current noise	$f = 1\text{ kHz}$		0.03		$\text{pA}\sqrt{\text{Hz}}$
THD	Total harmonic distortion	$f = 1\text{ kHz}$, $A_V = -2$, $R_L = 10\text{ k}\Omega$, $V_O = 4.1\text{ V}_{PP}$		0.01%		
		$f = 10\text{ kHz}$, $A_V = -2$, $R_L = 10\text{ k}\Omega$, $V_O = 8.5\text{ V}_{PP}$, $V^+ = 10\text{ V}$		0.01%		

- (1) All limits are specified by testing or statistical analysis.
- (2) Typical values represent the most likely parametric normal.
- (3) $V^+ = 15\text{ V}$. Connected as Voltage Follower with 10-V step input. Number specified is the slower of either the positive or negative slew rates.
- (4) Input referred, $V^+ = 15\text{ V}$ and $R_L = 100\text{ k}\Omega$ connected to 7.5 V. Each amplifier excited in turn with 1 kHz to produce $V_O = 12\text{ V}_{PP}$.

6.14 AC Electrical Characteristics: $V^+ = 3\text{ V}$, $V^- = 0\text{ V}$

unless otherwise specified, $V^+ = 3\text{ V}$, $V^- = 0\text{ V}$, $V_{CM} = V_O = V^+/2$, and $R_L > 1\text{ M}$

PARAMETER		TEST CONDITIONS	LMC6484AI, LMC6484I, LMC6484M			UNIT
			MIN ⁽¹⁾	TYP ⁽²⁾	MAX ⁽¹⁾	
SR	Slew rate ⁽³⁾			0.9		V/ μs
GBW	Gain-bandwidth product			1		MHz
THD	Total harmonic distortion	$f = 10\text{ kHz}$, $A_V = -2$, $R_L = 10\text{ k}\Omega$, $V_O = 2\text{ V}_{PP}$		0.01%		

- (1) All limits are specified by testing or statistical analysis.
- (2) Typical values represent the most likely parametric normal.
- (3) Connected as voltage follower with 2-V step input. Number specified is the slower of either the positive or negative slew rates.

6.15 Typical Characteristics

at $V_S = 15\text{ V}$, single supply, and $T_A = 25^\circ\text{C}$ (unless otherwise specified)

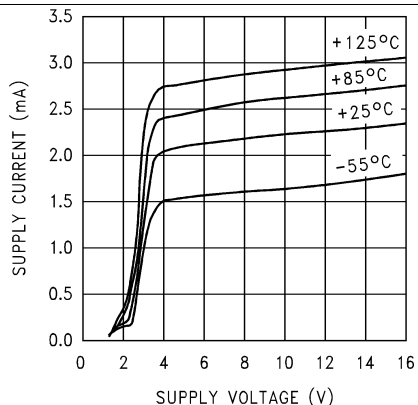

Figure 1. Supply Current vs Supply Voltage

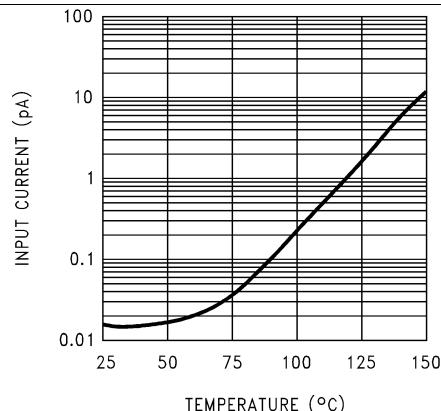

Figure 2. Input Current vs Temperature

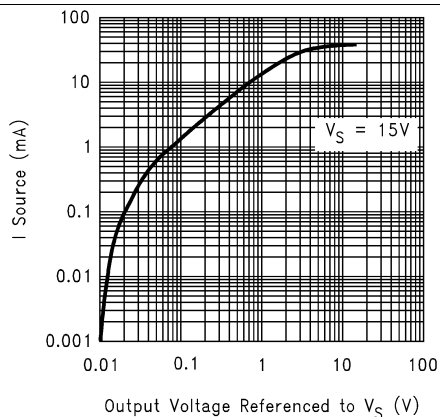

Figure 3. Sourcing Current vs Output Voltage

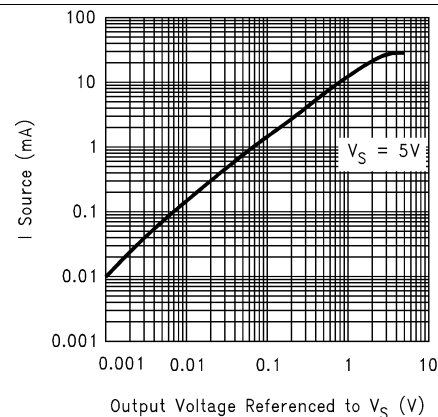

Figure 4. Sourcing Current vs Output Voltage

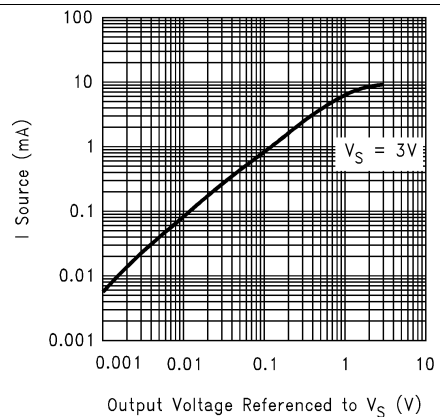

Figure 5. Sourcing Current vs Output Voltage

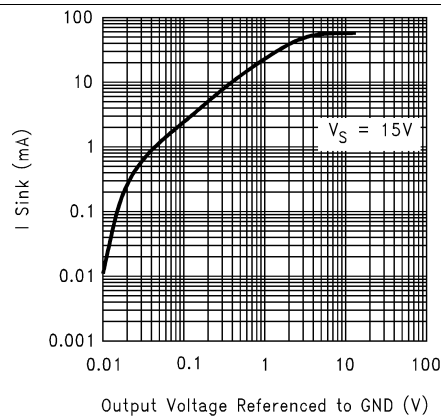

Figure 6. Sinking Current vs Output Voltage

Typical Characteristics (continued)

at $V_S = 15\text{ V}$, single supply, and $T_A = 25^\circ\text{C}$ (unless otherwise specified)

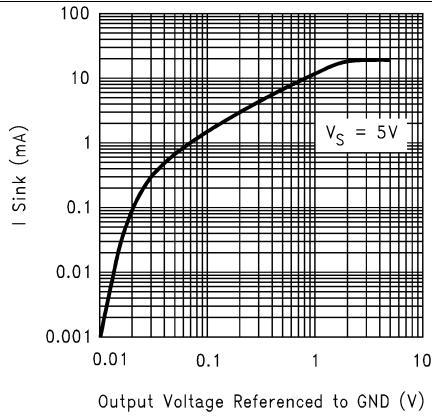

Figure 7. Sinking Current vs Output Voltage

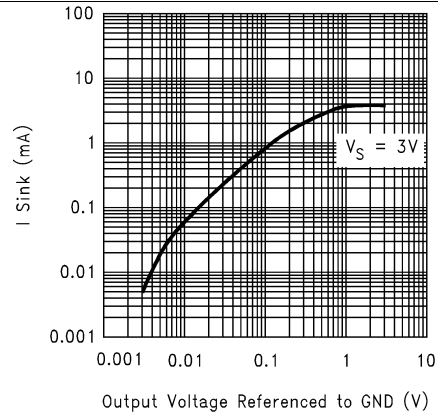

Figure 8. Sinking Current vs Output Voltage

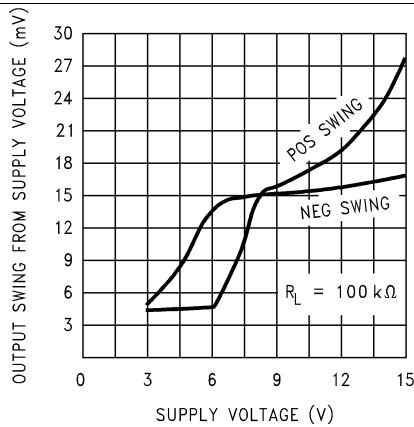

Figure 9. Output Voltage Swing vs Supply Voltage

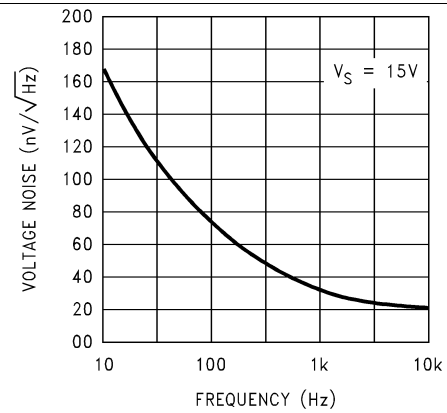

Figure 10. Input Voltage Noise vs Frequency

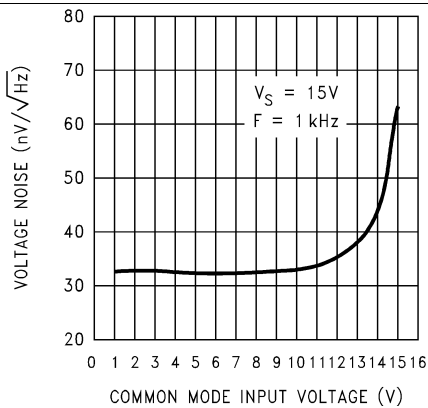

Figure 11. Input Voltage Noise vs Input Voltage

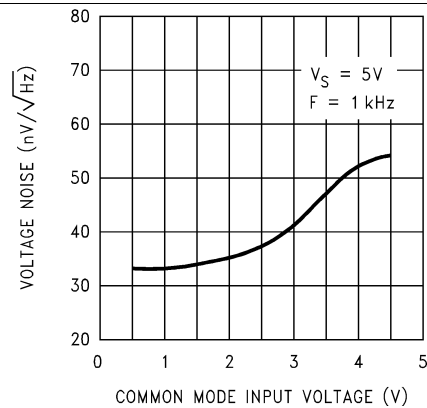

Figure 12. Input Voltage Noise vs Input Voltage

Typical Characteristics (continued)

at $V_S = 15\text{ V}$, single supply, and $T_A = 25^\circ\text{C}$ (unless otherwise specified)

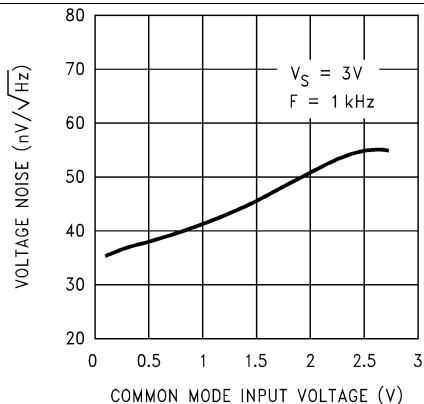

Figure 13. Input Voltage Noise vs Input Voltage

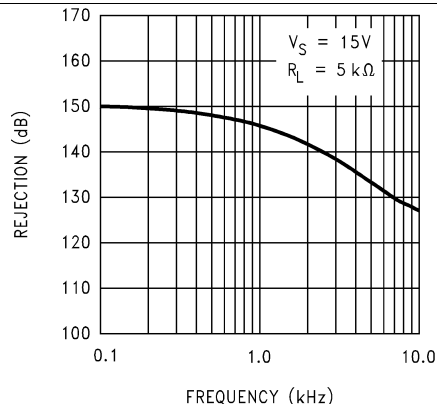

Figure 14. Crosstalk Rejection vs Frequency

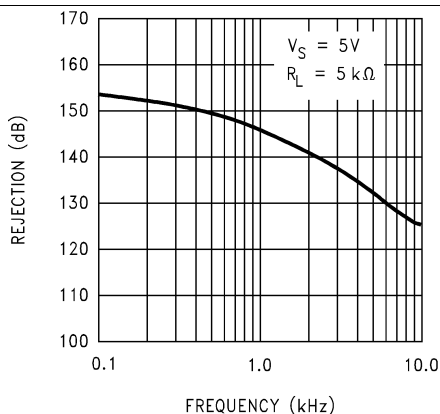

Figure 15. Crosstalk Rejection vs Frequency

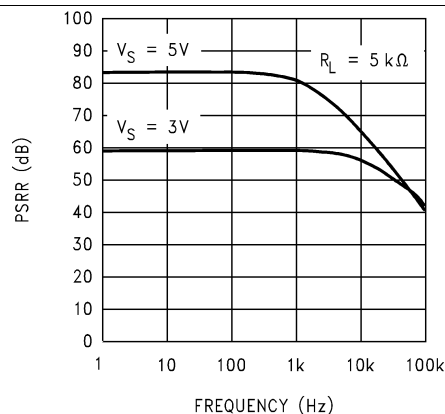

Figure 16. Positive PSRR vs Frequency

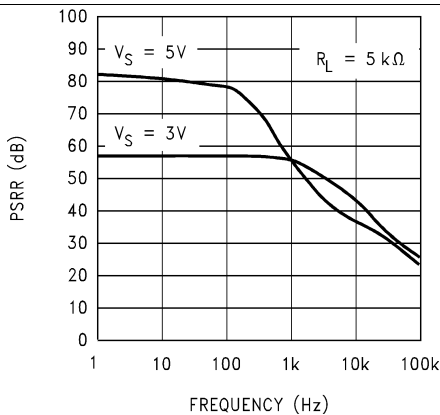

Figure 17. Negative PSRR vs Frequency

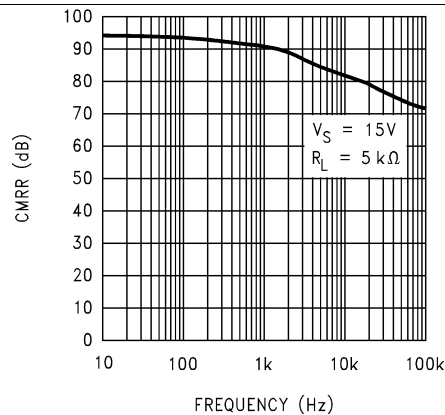

Figure 18. CMRR vs Frequency

Typical Characteristics (continued)

at $V_S = 15\text{ V}$, single supply, and $T_A = 25^\circ\text{C}$ (unless otherwise specified)

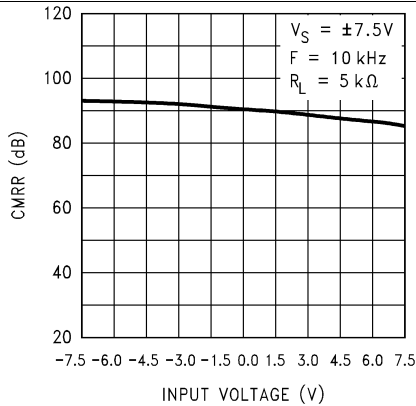

Figure 19. CMRR vs Input Voltage

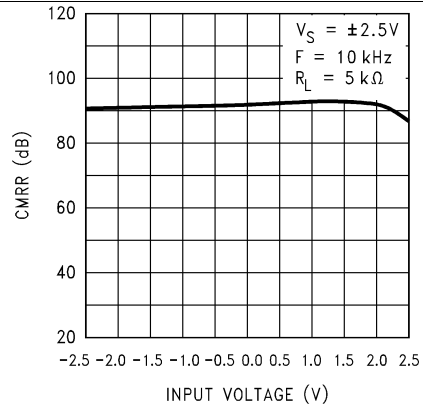

Figure 20. CMRR vs Input Voltage

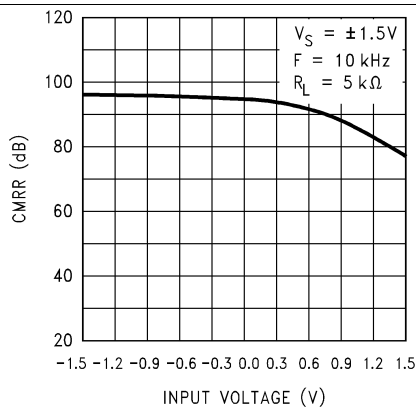

Figure 21. CMRR vs Input Voltage

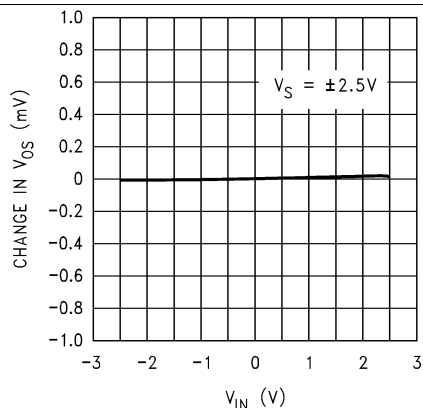

Figure 22. ΔV_{OS} vs CMR

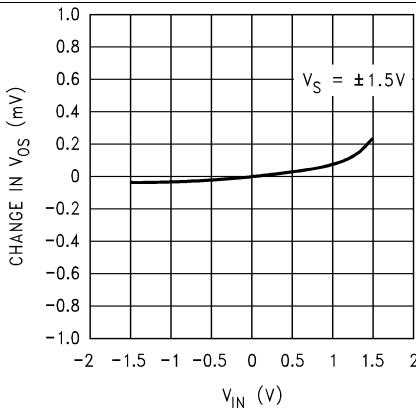

Figure 23. ΔV_{OS} vs CMR

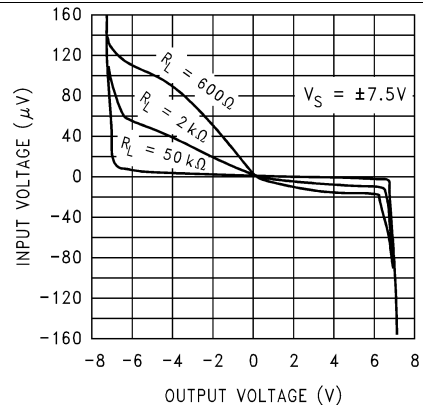

Figure 24. Input Voltage vs Output Voltage

Typical Characteristics (continued)

at $V_S = 15\text{ V}$, single supply, and $T_A = 25^\circ\text{C}$ (unless otherwise specified)

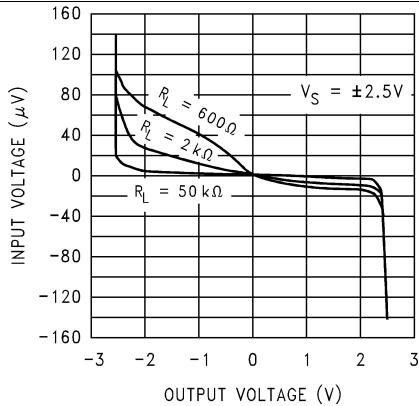

Figure 25. Input Voltage vs Output Voltage

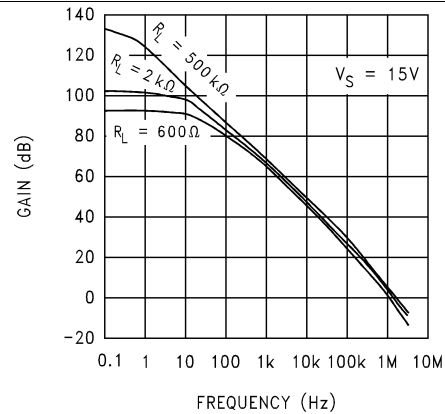

Figure 26. Open Loop Frequency Response

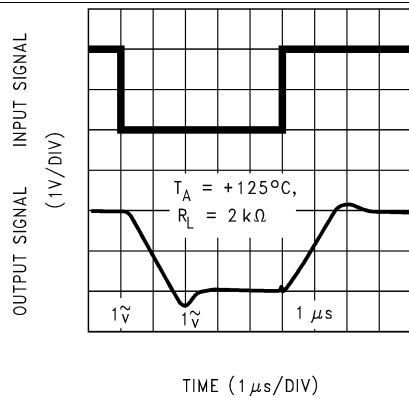

Figure 27. Noninverting Large Signal Pulse Response

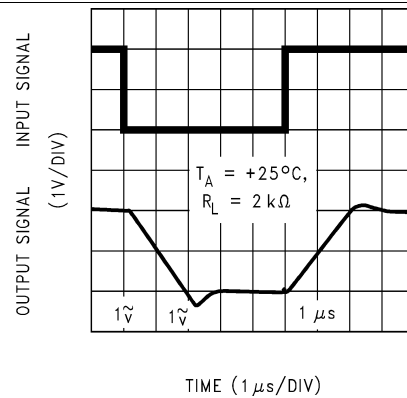

Figure 28. Noninverting Large Signal Pulse Response

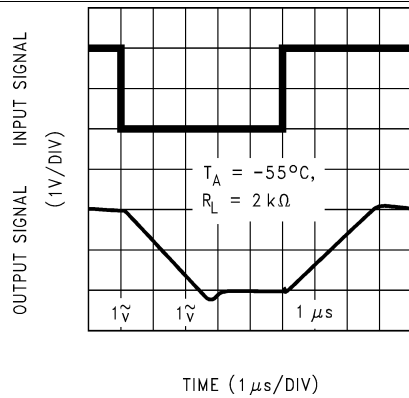

Figure 29. Noninverting Large Signal Pulse Response

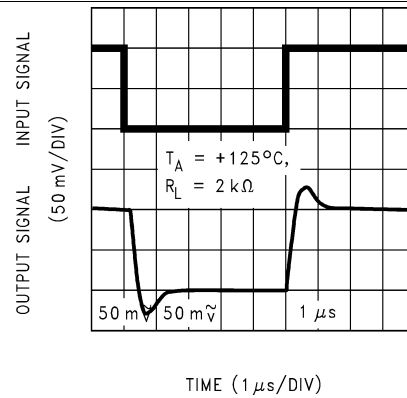

Figure 30. Noninverting Small Signal Pulse Response

Typical Characteristics (continued)

at $V_S = 15\text{ V}$, single supply, and $T_A = 25^\circ\text{C}$ (unless otherwise specified)

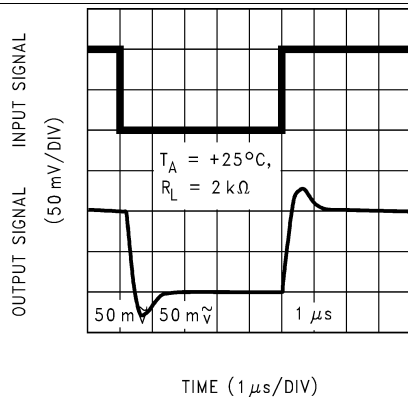

Figure 31. Noninverting Small Signal Pulse Response

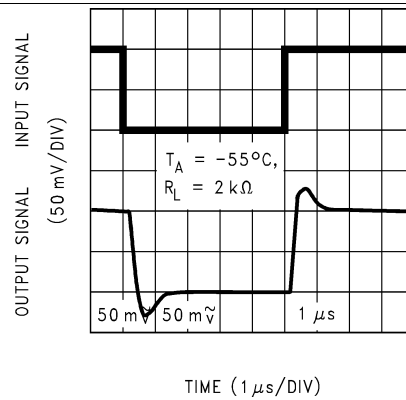

Figure 32. Noninverting Small Signal Pulse Response

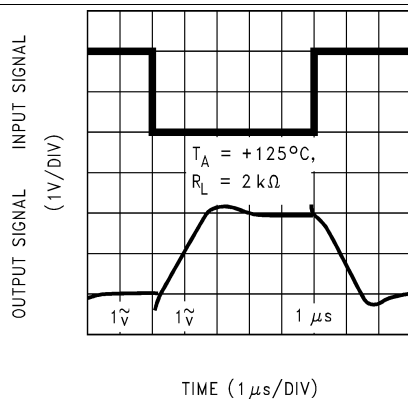

Figure 33. Inverting Large Signal Pulse Response

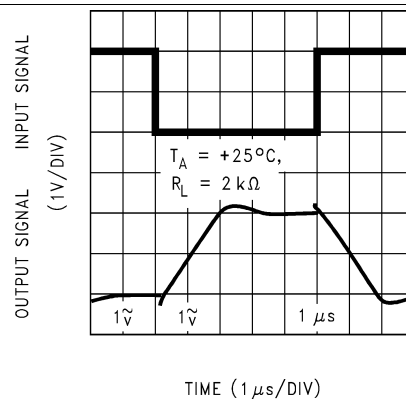

Figure 34. Inverting Large Signal Pulse Response

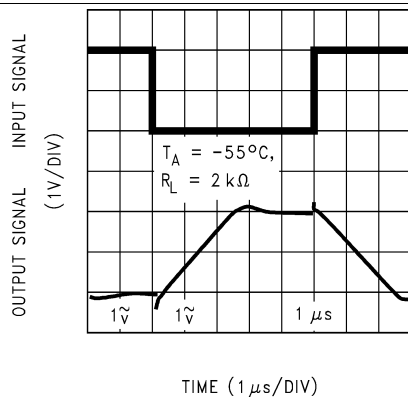

Figure 35. Inverting Large Signal Pulse Response

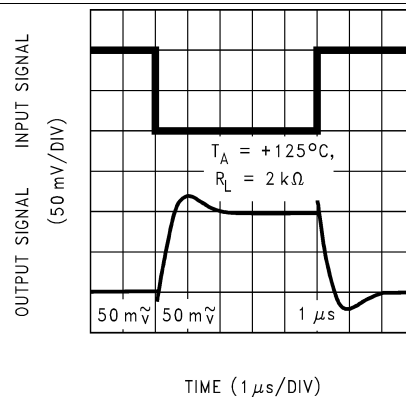

Figure 36. Inverting Small Signal Pulse Response

Typical Characteristics (continued)

at $V_S = 15\text{ V}$, single supply, and $T_A = 25^\circ\text{C}$ (unless otherwise specified)

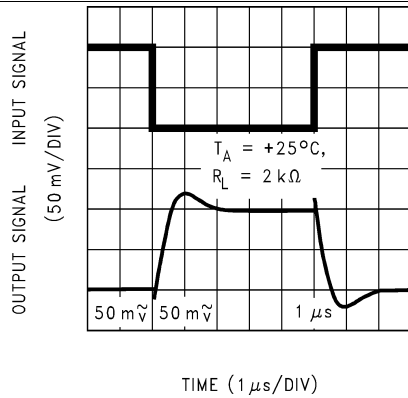

Figure 37. Inverting Small Signal Pulse Response

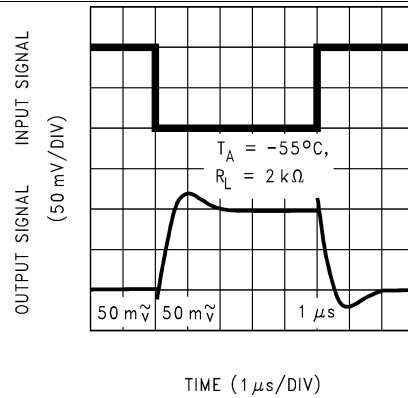

Figure 38. Inverting Small Signal Pulse Response

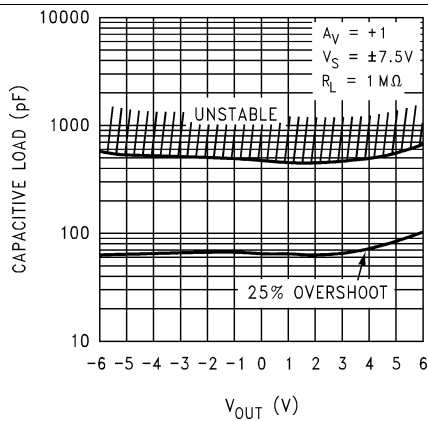

Figure 39. Stability vs Capacitive Load

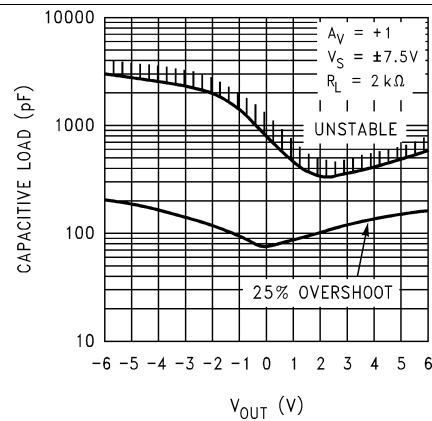

Figure 40. Stability vs Capacitive Load

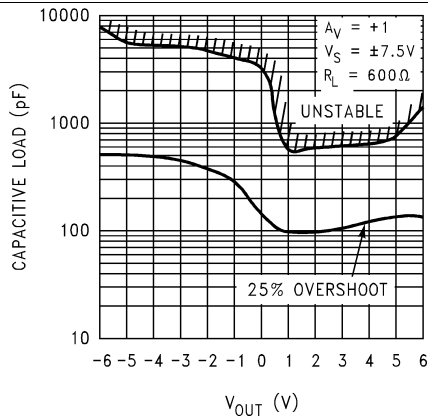

Figure 41. Stability vs Capacitive Load

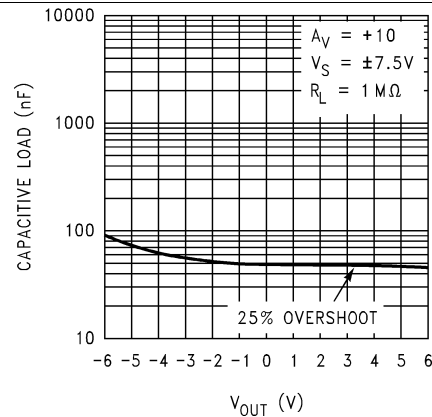

Figure 42. Stability vs Capacitive Load

Typical Characteristics (continued)

at $V_S = 15\text{ V}$, single supply, and $T_A = 25^\circ\text{C}$ (unless otherwise specified)

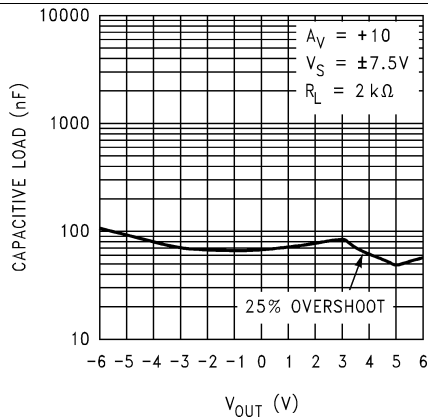

Figure 43. Stability vs Capacitive Load

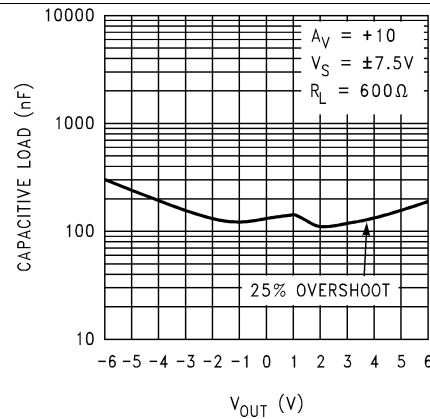

Figure 44. Stability vs Capacitive Load

7 Detailed Description

7.1 Overview

The LMC6484 is a quad operational amplifier that offers a low-cost, low-power amplifier for applications requiring multiple operational amplifier stages and rail-to-rail operation. This device supports a wide supply range (3 V to 15 V) and excellent amplifier-to-amplifier isolation (150 dB typical). This device is an excellent choice for battery-powered signal acquisition systems requiring highly integrated solutions to achieve efficient layout.

7.2 Functional Block Diagram

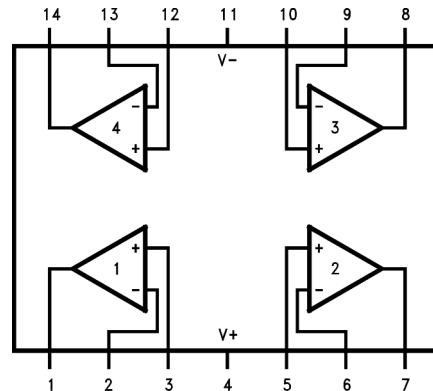

7.3 Feature Description

7.3.1 Amplifier Topology

The LMC6484 incorporates specially designed, wide-compliance range current mirrors, and the body effect to extend input common-mode range to each supply rail. Complementary, paralleled, differential input stages, like the type used in other CMOS and bipolar rail-to-rail input amplifiers, are not used because of their inherent accuracy problems due to CMRR, crossover distortion, and open-loop gain variation.

The input stage design of the LMC6484 is complemented by an output stage capable of rail-to-rail output swing even when driving a large load. Rail-to-rail output swing is obtained by taking the output directly from the internal integrator instead of an output buffer stage.

7.3.2 Input Common-Mode Voltage Range

Unlike Bi-FET amplifier designs, the LMC6484 does not exhibit phase inversion when an input voltage exceeds the negative supply voltage. Figure 46 shows an input voltage exceeding both supplies with no resulting phase inversion on the output.

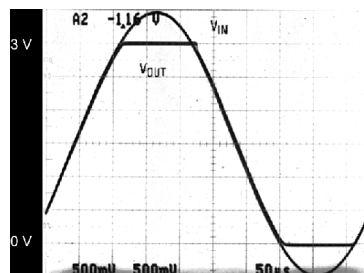

Figure 45. An Input Voltage Signal Exceeds the LMC6484 Power Supply Voltages With No Output Phase Inversion

Feature Description (continued)

The absolute maximum input voltage is 300 mV beyond either supply rail at room temperature. Voltages greatly exceeding this absolute maximum rating, as in [Figure 46](#), can cause excessive current to flow in or out of the input pins possibly affecting reliability.

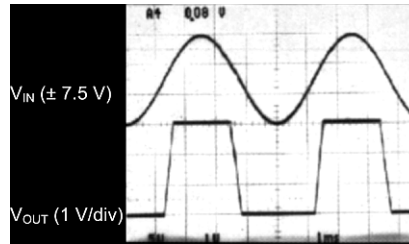

Figure 46. A $\pm 7.5\text{V}$ Input Signal Greatly Exceeds the 3-V Supply in [Figure 47](#) Causing No Phase Inversion due to R_I

Applications that exceed this rating must externally limit the maximum input current to $\pm 5\text{ mA}$ with an input resistor, as shown in [Figure 47](#).

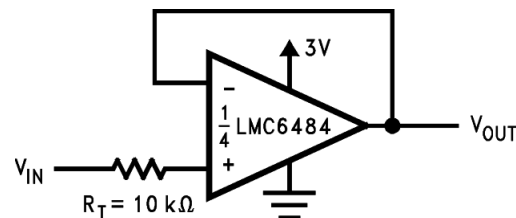

Figure 47. R_I Input Current Protection for Voltages Exceeding the Supply Voltage

7.3.3 Rail-to-Rail Output

The approximated output resistance of the LMC6484 is $180\text{-}\Omega$ sourcing and $130\text{-}\Omega$ sinking at $V_S = 3\text{ V}$, and $110\text{-}\Omega$ sourcing and $83\text{-}\Omega$ sinking at $V_S = 5\text{ V}$. Using the calculated output resistance, the maximum output voltage swing can be estimated as a function of load.

7.4 Device Functional Modes

The LMC6482 may be used in applications where each amplifier channel is used independently, or in applications with cascaded channels. See the [Typical Application](#) section for more information.

8 Application and Implementation

NOTE

Information in the following applications sections is not part of the TI component specification, and TI does not warrant its accuracy or completeness. TI's customers are responsible for determining suitability of components for their purposes. Customers should validate and test their design implementation to confirm system functionality.

8.1 Application Information

8.1.1 Upgrading Applications

The LMC6484 quad-channel devices and LMC6482 dual-channel devices have industry standard pinouts to retrofit existing applications. System performance can be greatly increased by the features of the LMC6484. The key benefit of designing in the LMC6484 is increased linear signal range. Most operational amplifiers have limited input common-mode ranges. Signals that exceed this range generate a nonlinear output response that persists long after the input signal returns to the common-mode range.

Linear signal range is vital in applications such as filters, where signal peaking can exceed input common-mode ranges, and result in output phase inversion or severe distortion.

8.1.2 Spice Macromodel

A spice macromodel is available for the LMC6484. This model includes accurate simulation of the following:

- Input common-mode voltage range
- Frequency and transient response
- GBW dependence on loading conditions
- Quiescent and dynamic supply current
- Output swing dependence on loading conditions
- Many more characteristics, as listed on the macromodel disk.

Contact your local Texas Instruments sales office to obtain an operational amplifier spice model library disk.

8.2 Typical Application

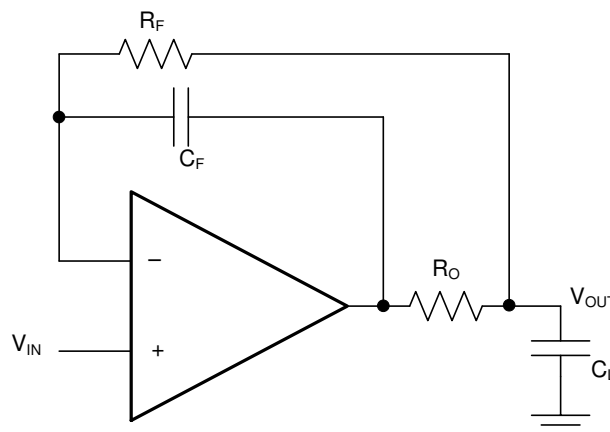

Figure 48. Unity Gain Buffer for High-Capacitive Loads

Typical Application (continued)

8.2.1 Design Requirements

- For best performance, make sure that the input voltage swing is between $V+$ and $V-$.
- Make sure that the input does not exceed the common-mode input range.
- To reduce the risk of de-stabilizing the output, use resistive isolation on the output when driving capacitive loads (see the [Capacitive Load Compensation](#) section).
- When large feedback resistors are used, compensate for parasitic capacitance on the input as needed (see the [Compensating for Input Capacitance](#) section).

8.2.2 Detailed Design Procedure

8.2.2.1 Capacitive Load Compensation

The LMC6484 typically directly drives a 100-pF load with $V_S = 15\text{ V}$ at unity gain without oscillating. The unity gain follower is the most sensitive configuration. Direct capacitive loading reduces the phase margin of operational amplifiers. The combination of the output impedance of the operational amplifier and the capacitive load induces phase lag that results in either an under-damped pulse response or oscillation.

Capacitive load compensation can be accomplished using resistive isolation, as shown in [Figure 49](#). This simple technique is useful for isolating the capacitive input of multiplexers and analog-to-digital converters (ADCs).

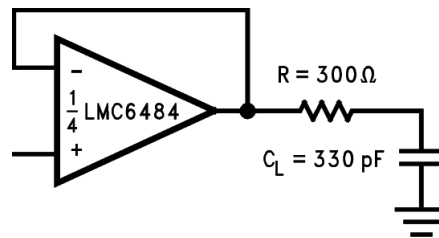

Figure 49. Resistive Isolation of a 330-pF Capacitive Load

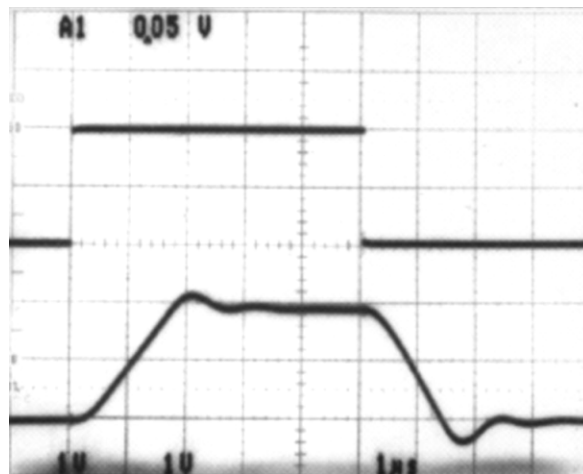

Figure 50. Pulse Response of the LMC6484 Circuit in [Figure 49](#)

Typical Application (continued)

Improved frequency response is achieved by indirectly driving capacitive loads as shown in Figure 51.

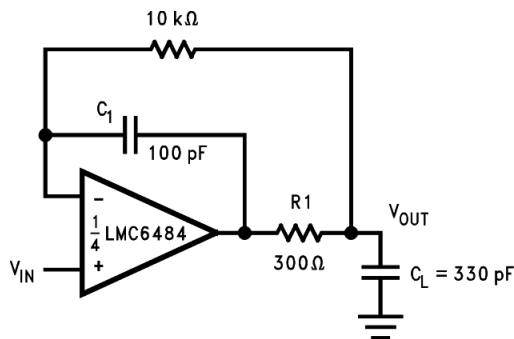

Figure 51. LMC6484 Noninverting Amplifier Compensated to Handle a 330-pF Capacitive Load

R1 and C1 serve to counteract the loss of phase margin by feeding forward the high-frequency component of the output signal back to the inverting input of the amplifier; thereby, preserving phase margin in the overall feedback loop. The values of R1 and C1 are experimentally determined for the desired pulse response. The resulting pulse response is seen in Figure 52.

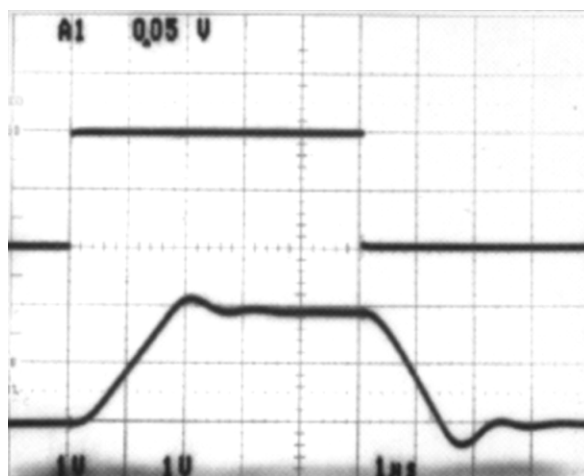

Figure 52. Pulse Response of LMC6484 Circuit in Figure 51

Typical Application (continued)

8.2.2.2 Compensating for Input Capacitance

Large values of feedback resistance are often used with amplifiers that have ultra-low input current, such as the LMC6484. Large feedback resistors can react with small values of input capacitance due to transducers, photodiodes, and circuit-board parasitics to reduce phase margins.

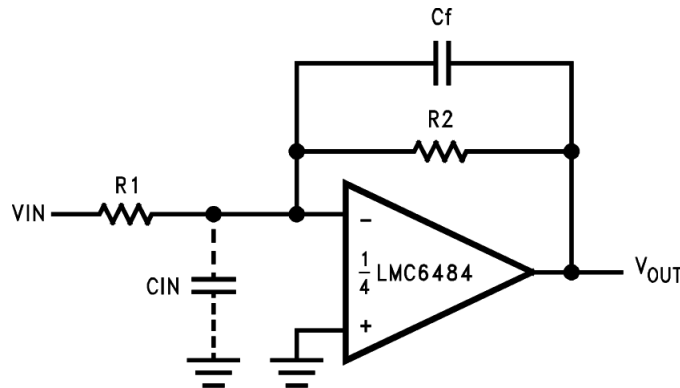

Figure 53. Canceling the Effect of Input Capacitance

To compensate for the effect of input capacitance, add a feedback capacitor. The feedback capacitor (as in Figure 53), Cf, is first estimated by Equation 1:

$$\frac{1}{2\pi R_1 C_{IN}} \geq \frac{1}{2\pi R_2 C_f}$$

or

$$R_1 C_{IN} \leq R_2 C_f \tag{1}$$

This equation typically provides significant overcompensation. Printed circuit board (PCB) stray capacitance may be larger or smaller than that of a breadboard, so the actual optimum value for Cf may be different. The values of Cf should be checked on the actual circuit. See the [LMC660 Quad CMOS Amplifier data sheet](#) for a more detailed discussion.

8.2.2.3 Offset Voltage Adjustment

Offset voltage adjustment circuits are illustrated in Figure 54 and Figure 55. Large-value resistances and potentiometers are used to reduce power consumption while providing typically ±2.5 mV of adjustment range, referred to the input, for both configurations with VS = ±5 V.

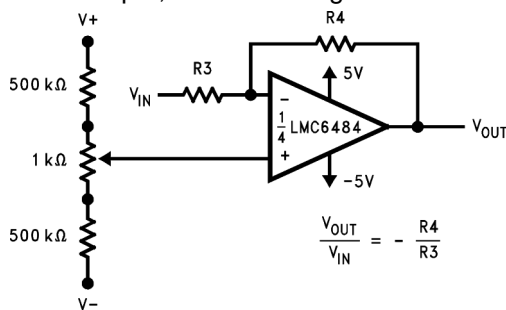

Figure 54. Inverting Configuration Offset Voltage Adjustment

$$\frac{V_{OUT}}{V_{IN}} = - \frac{R_4}{R_3}$$

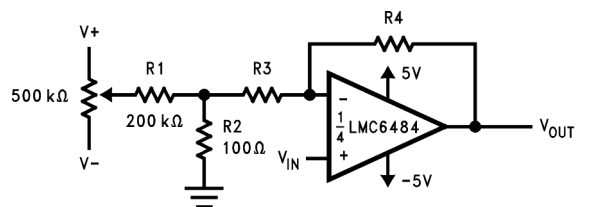

Figure 55. Noninverting Configuration Offset Voltage Adjustment

$$\frac{V_{OUT}}{V_{IN}} = 1 + \frac{R_4}{R_3} ; R_2 \ll R_3$$

Typical Application (continued)

8.2.3 Application Curves

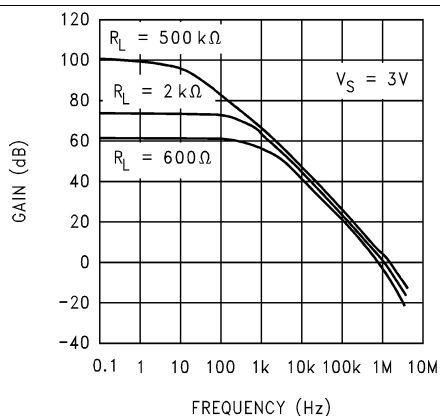

Figure 56. Open Loop Frequency Response

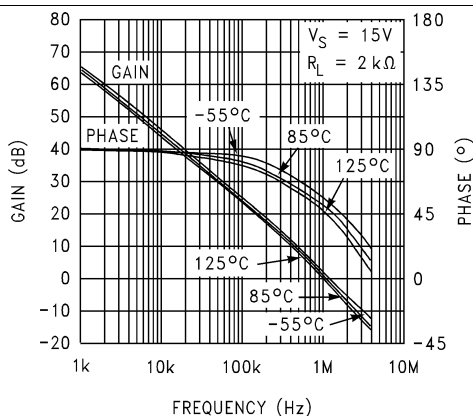

Figure 57. Open Loop Frequency Response vs Temperature

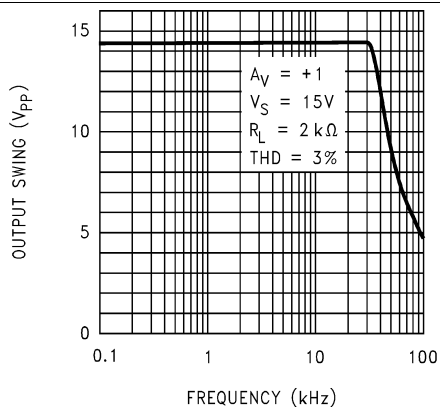

Figure 58. Maximum Output Swing vs Frequency

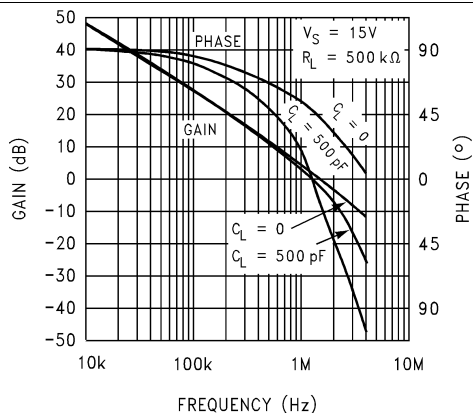

Figure 59. Gain and Phase vs Capacitive Load

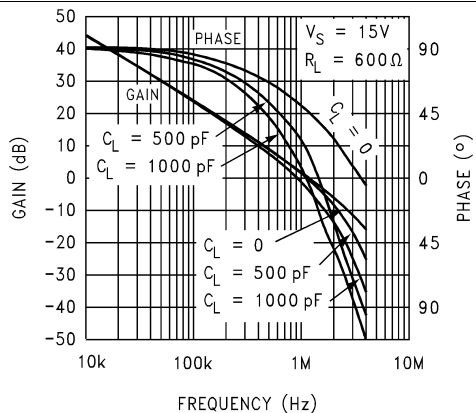

Figure 60. Gain and Phase vs Capacitive Load

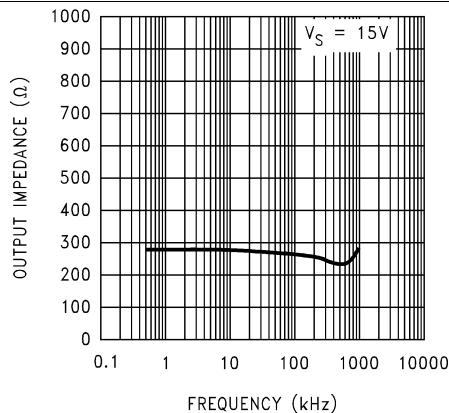

Figure 61. Open Loop Output Impedance vs Frequency

Typical Application (continued)

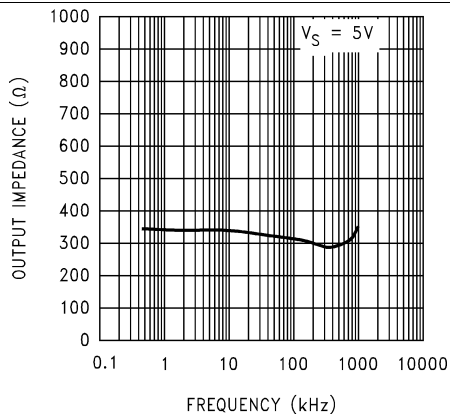

Figure 62. Open Loop Output Impedance vs Frequency

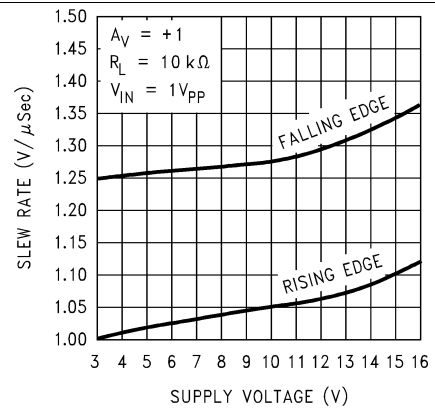

Figure 63. Slew Rate vs Supply Voltage

8.3 System Examples

The circuit in Figure 64 uses a single supply to half-wave rectify a sinusoid centered about ground. R_1 limits current into the amplifier caused by the input voltage exceeding the supply voltage. Figure 65 shows the half-wave rectifier waveform. Full-wave rectification is provided by the circuit in Figure 66.

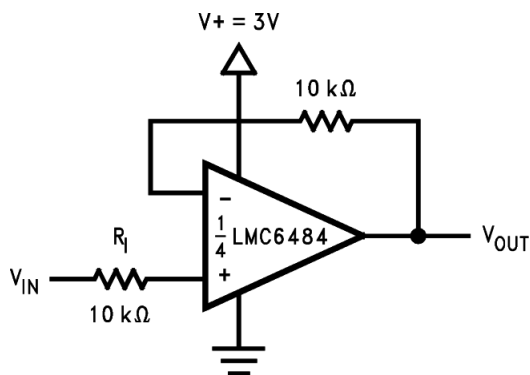

Figure 64. Half-Wave Rectifier With Input Current Protection (R_1)

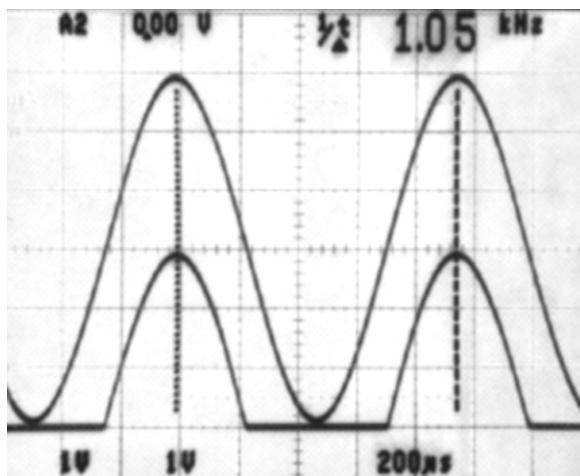

Figure 65. Half-Wave Rectifier Waveform

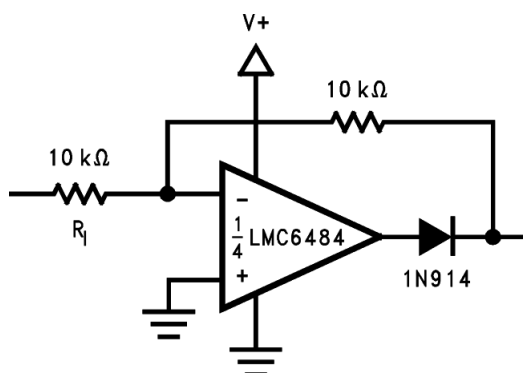

Figure 66. Full Wave Rectifier With Input Current Protection (R_1)

System Examples (continued)

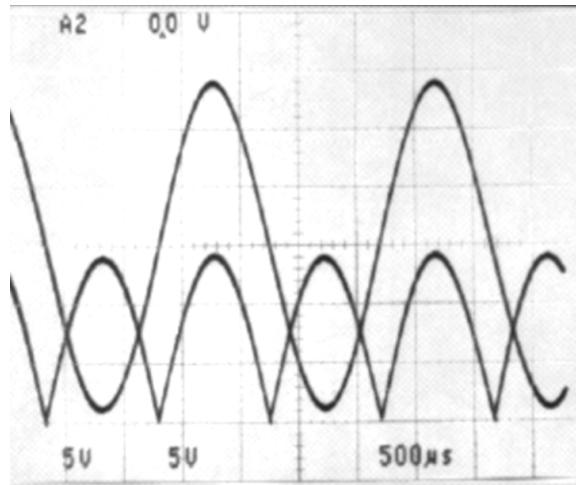

Figure 67. Full Wave Rectifier Waveform

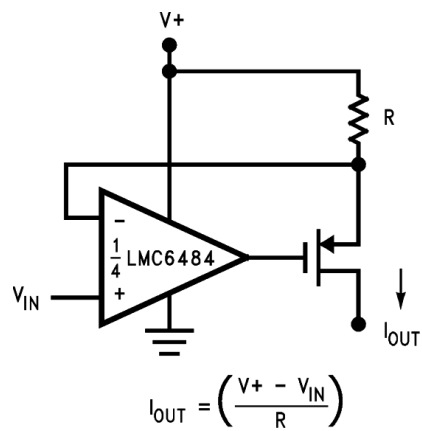

Figure 68. Large Compliance Range Current Source

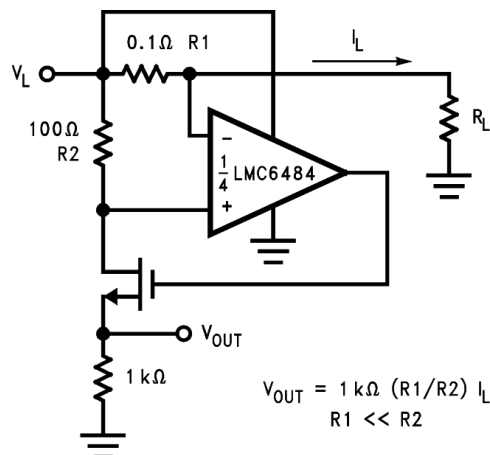

Figure 69. Positive Supply Current Sense

System Examples (continued)

In Figure 70, dielectric absorption and leakage is minimized by using a polystyrene or polyethylene hold capacitor. The droop rate is primarily determined by the value of CH and the diode leakage current. The ultra-low input current of the LMC6484 has a negligible effect on droop.

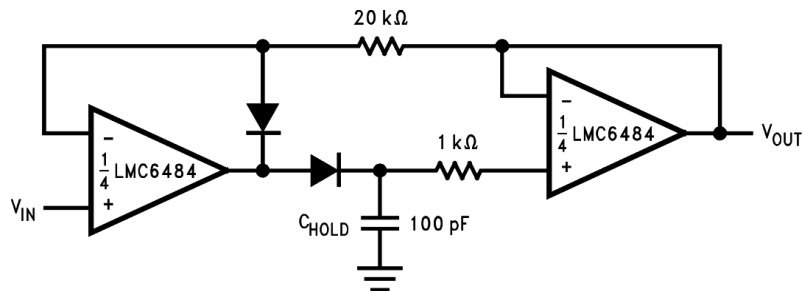

Figure 70. Low Voltage Peak Detector With Rail-to-Rail Peak Capture Range

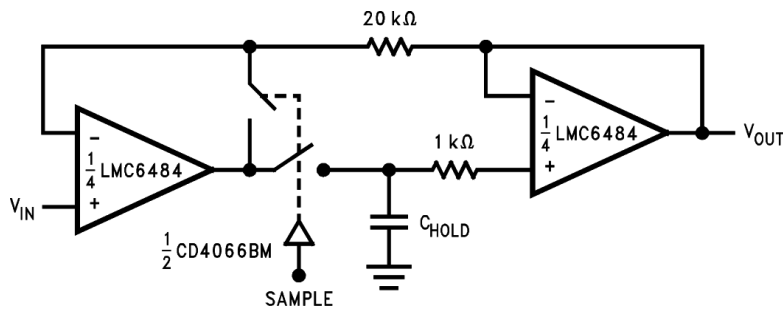
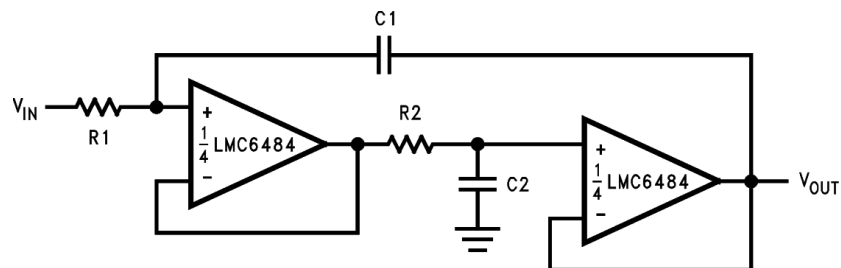

Figure 71. Rail-to-Rail Sample and Hold

The high CMRR (85 dB) of the LMC6484 allows excellent accuracy throughout the rail-to-rail dynamic capture range of the circuit.

The low-pass filter circuit in Figure 72 can be used as an antialiasing filter with the same voltage supply as the ADC. Filter designs can also take advantage of the LMC6484 ultra-low input current. The ultra-low input current yields negligible offset error even when large value resistors are used, which allows the use of smaller-valued capacitors that take up less board space and cost less.



$$R1 = R2, C1 = C2; f = \frac{1}{2\pi R1 C1}; DF = \frac{1}{2} \sqrt{\frac{C2}{C1}} \sqrt{\frac{R2}{R1}}$$

Figure 72. Rail-to-Rail, Single-Supply, Low-Pass Filter

System Examples (continued)

8.3.1 Data Acquisition Systems

Low-power, single-supply, data acquisition system solutions are provided by buffering the [ADC12038](#) with the LMC6484, as shown in [Figure 73](#). Capable of using the full supply range, the LMC6484 does not require input signals to be scaled down to meet limited common-mode voltage ranges. The LMC6484 CMRR of 82 dB maintains integral linearity of a 12-bit data acquisition system to ± 0.325 LSB. Other rail-to-rail input amplifiers with only 50 dB of CMRR degrade the accuracy of the data acquisition system to only 8 bits.

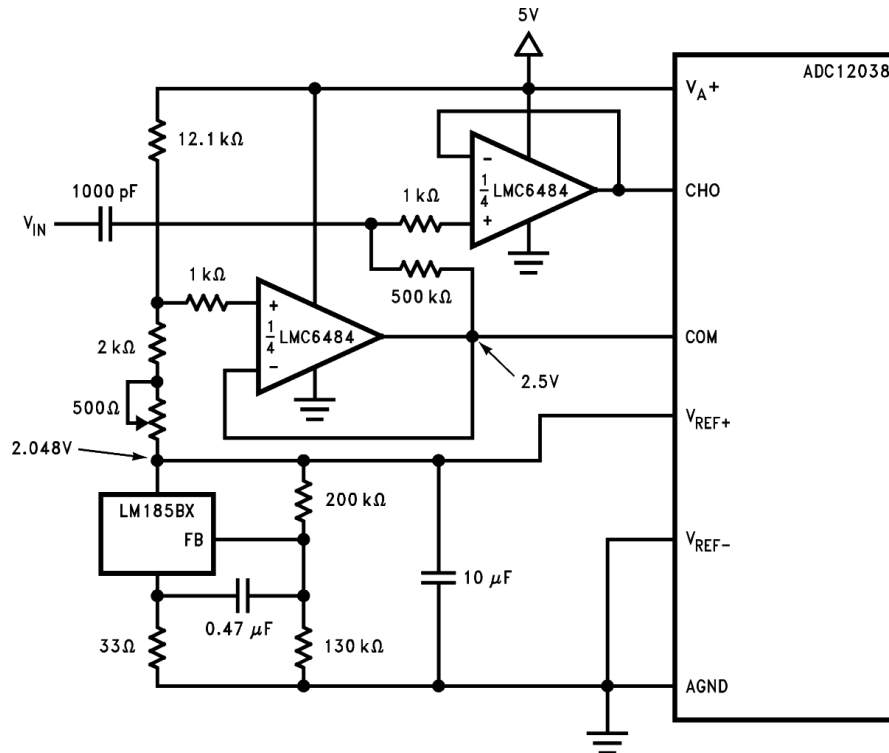

Figure 73. Operating From the Same Supply Voltage, the LMC6484 Buffers the ADC12038 Maintaining Excellent Accuracy

System Examples (continued)

8.3.2 Instrumentation Circuits

The LMC6484 has the high input impedance, large common-mode range, and high CMRR required for designing instrumentation circuits. Instrumentation circuits designed with the LMC6484 can reject a larger range of common-mode signals than most instrumentation amps. Thus, instrumentation circuits designed with the LMC6484 are an excellent choice for noisy or industrial environments. Other applications that benefit from these features include analytic medical instruments, magnetic field detectors, gas detectors, and silicon-based transducers.

A small-valued potentiometer is used in series with R_G to set the differential gain of the three-op-amp instrumentation circuit in Figure 74. This combination is used instead of one large valued potentiometer to increase gain trim accuracy and reduce error due to vibration.

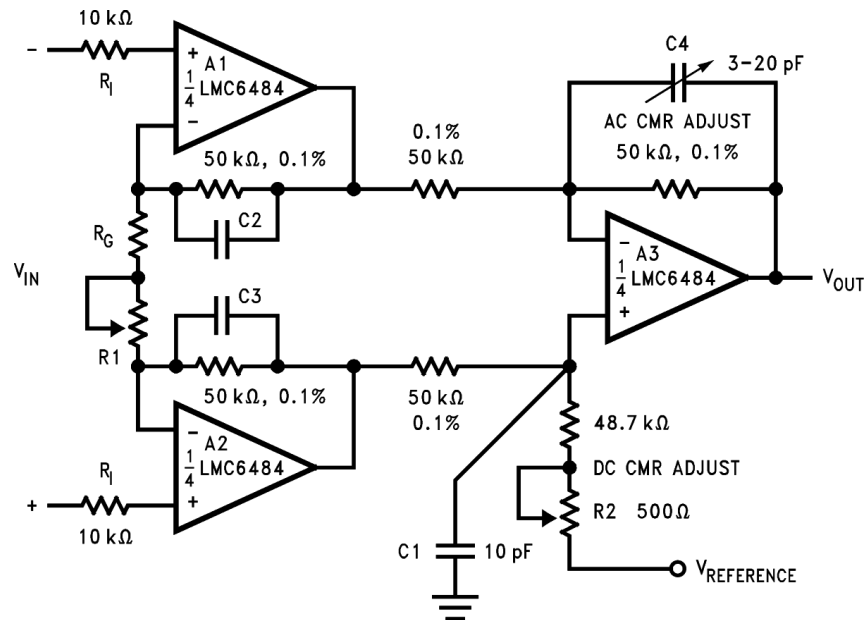

Figure 74. Low-Power, Three-Op-Amp Instrumentation Amplifier

A two-op-amp instrumentation amplifier designed for a gain of 100 is shown in Figure 75. Low sensitivity trimming is made for offset voltage, CMRR, and gain. Low cost and low power consumption are the main advantages of this two-op-amp circuit.

Higher frequency and larger common-mode range applications are best facilitated by a three-op-amp instrumentation amplifier.

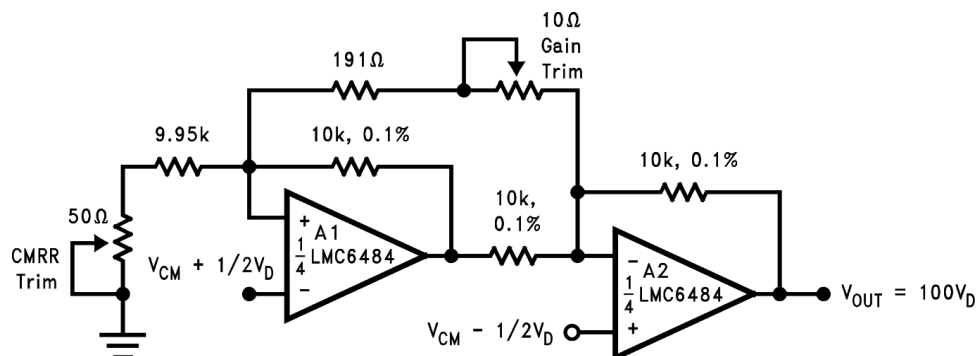

Figure 75. Low-Power Two-Op-Amp Instrumentation Amplifier

9 Power Supply Recommendations

The LMC6482 can be operated over a supply range of 3 V to 15 V. To achieve noise immunity as appropriate to the application, make sure to use good PCB layout practices for power supply rails and planes, as well as using bypass capacitors connected between the power supply pins and ground.

10 Layout

10.1 Layout Guidelines

10.1.1 Printed-Circuit-Board Layout for High-Impedance Work

Any circuit that must operate with less than 1000 pA of leakage current requires special layout of the PCB. To take advantage of the ultra-low input current of the LMC6484 (typically, less than 20 fA), make sure to have an excellent layout. Fortunately, the techniques for obtaining low leakages are quite simple. First, do not ignore the surface leakage of the PCB, even though this leakage may sometimes appear acceptably low, because under conditions of high humidity or dust or contamination, the surface leakage will be appreciable.

To minimize the effect of any surface leakage, lay out a ring of foil completely surrounding the LMC6484 inputs and the terminals of capacitors, diodes, conductors, resistors, relay terminals, and so on, connected to the operational amplifier inputs, as in Figure 78. To have a significant effect, place guard rings in both the top and bottom of the PCB. This PC foil must then be connected to a voltage that is at the same voltage as the amplifier inputs, because no leakage current can flow between two points at the same potential. For example, a PCB trace-to-pad resistance of $10^{12} \Omega$, which is normally considered a very large resistance, could leak 5 pA if the trace were a 5-V bus adjacent to the pad of the input. This leakage would cause a 250 times degradation from the actual performance of the LMC6484. However, if a guard ring is held within 5 mV of the inputs, then even a resistance of $10^{11} \Omega$ would cause only 0.05 pA of leakage current. Figure 76 shows the typical connections of guard rings for standard operational amplifier configurations.

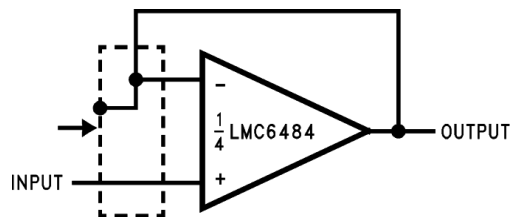
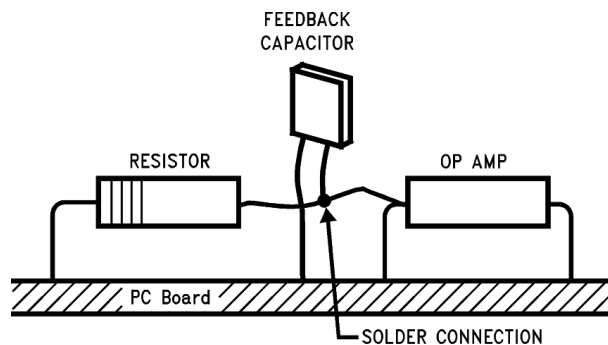

Figure 76. Typical Connections of Guard Rings

Be aware that when it is inappropriate to lay out a PCB for the sake of just a few circuits, another technique even better than a guard ring on a PCB: do *not* insert the input pin of the amplifier into the PCB at all, but bend the input pin up in the air and use only air as an insulator. Air is an excellent insulator. In this case, you may have to forego some of the advantages of PCB construction, but the advantages are sometimes well worth the effort of using point-to-point, up-in-the-air wiring, as shown in Figure 77.



NOTE: Input pins are lifted out of PCB and soldered directly to components. All other pins connected to PCB.

Figure 77. Air Wiring

10.2 Layout Example

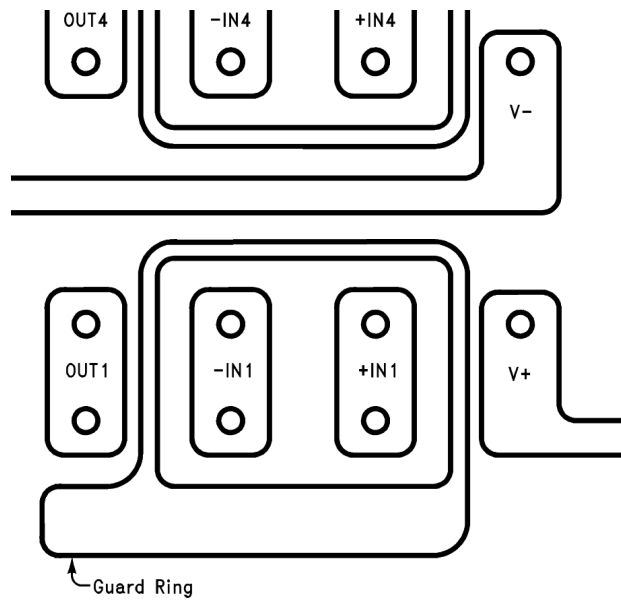

Figure 78. Example of Guard Ring in a PCB Layout

11 Device and Documentation Support

11.1 Device Support

For the LMC6584 PSpice model, see [SNOM165](#).

11.2 Documentation Support

11.2.1 Related Documentation

For related documentation, see the following:

- [LMC6482 CMOS Dual Rail-To-Rail Input and Output Operational Amplifier data sheet](#)
- [LMC660 CMOS Quad Operational Amplifier data sheet](#)

11.3 Support Resources

TI E2E™ [support forums](#) are an engineer's go-to source for fast, verified answers and design help — straight from the experts. Search existing answers or ask your own question to get the quick design help you need.

Linked content is provided "AS IS" by the respective contributors. They do not constitute TI specifications and do not necessarily reflect TI's views; see TI's [Terms of Use](#).

11.4 Trademarks

E2E is a trademark of Texas Instruments.

All other trademarks are the property of their respective owners.

11.5 Electrostatic Discharge Caution



These devices have limited built-in ESD protection. The leads should be shorted together or the device placed in conductive foam during storage or handling to prevent electrostatic damage to the MOS gates.

11.6 Glossary

[SLYZ022](#) — *TI Glossary*.

This glossary lists and explains terms, acronyms, and definitions.

12 Mechanical, Packaging, and Orderable Information

The following pages include mechanical, packaging, and orderable information. This information is the most current data available for the designated devices. This data is subject to change without notice and revision of this document. For browser-based versions of this data sheet, refer to the left-hand navigation.

PACKAGING INFORMATION

Orderable Device	Status (1)	Package Type	Package Drawing	Pins	Package Qty	Eco Plan (2)	Lead finish/ Ball material (6)	MSL Peak Temp (3)	Op Temp (°C)	Device Marking (4/5)	Samples
LMC6484AIM	NRND	SOIC	D	14	55	Non-RoHS & Green	Call TI	Level-1-235C-UNLIM	-40 to 85	LMC6484 AIM	
LMC6484AIM/NOPB	ACTIVE	SOIC	D	14	55	RoHS & Green	SN	Level-1-260C-UNLIM	-40 to 85	LMC6484 AIM	Samples
LMC6484AIMX	NRND	SOIC	D	14	2500	Non-RoHS & Green	Call TI	Level-1-235C-UNLIM	-40 to 85	LMC6484 AIM	
LMC6484AIMX/NOPB	ACTIVE	SOIC	D	14	2500	RoHS & Green	SN	Level-1-260C-UNLIM	-40 to 85	LMC6484 AIM	Samples
LMC6484AIN/NOPB	ACTIVE	PDIP	N	14	25	RoHS & Green	Call TI SN	Level-1-NA-UNLIM	-40 to 85	LMC6484AIN	Samples
LMC6484IM	NRND	SOIC	D	14	55	Non-RoHS & Green	Call TI	Level-1-235C-UNLIM	-40 to 85	LMC6484IM	
LMC6484IM/NOPB	ACTIVE	SOIC	D	14	55	RoHS & Green	SN	Level-1-260C-UNLIM	-40 to 85	LMC6484IM	Samples
LMC6484IMX	NRND	SOIC	D	14	2500	Non-RoHS & Green	Call TI	Level-1-235C-UNLIM	-40 to 85	LMC6484IM	
LMC6484IMX/NOPB	ACTIVE	SOIC	D	14	2500	RoHS & Green	SN	Level-1-260C-UNLIM	-40 to 85	LMC6484IM	Samples
LMC6484IN/NOPB	ACTIVE	PDIP	N	14	25	RoHS & Green	Call TI SN	Level-1-NA-UNLIM	-40 to 85	LMC6484IN	Samples

(1) The marketing status values are defined as follows:

ACTIVE: Product device recommended for new designs.

LIFEBUY: TI has announced that the device will be discontinued, and a lifetime-buy period is in effect.

NRND: Not recommended for new designs. Device is in production to support existing customers, but TI does not recommend using this part in a new design.

PREVIEW: Device has been announced but is not in production. Samples may or may not be available.

OBSOLETE: TI has discontinued the production of the device.

(2) **RoHS:** TI defines "RoHS" to mean semiconductor products that are compliant with the current EU RoHS requirements for all 10 RoHS substances, including the requirement that RoHS substance do not exceed 0.1% by weight in homogeneous materials. Where designed to be soldered at high temperatures, "RoHS" products are suitable for use in specified lead-free processes. TI may reference these types of products as "Pb-Free".

RoHS Exempt: TI defines "RoHS Exempt" to mean products that contain lead but are compliant with EU RoHS pursuant to a specific EU RoHS exemption.

Green: TI defines "Green" to mean the content of Chlorine (Cl) and Bromine (Br) based flame retardants meet JS709B low halogen requirements of <=1000ppm threshold. Antimony trioxide based flame retardants must also meet the <=1000ppm threshold requirement.

(3) MSL, Peak Temp. - The Moisture Sensitivity Level rating according to the JEDEC industry standard classifications, and peak solder temperature.

- (4) There may be additional marking, which relates to the logo, the lot trace code information, or the environmental category on the device.
- (5) Multiple Device Markings will be inside parentheses. Only one Device Marking contained in parentheses and separated by a "~" will appear on a device. If a line is indented then it is a continuation of the previous line and the two combined represent the entire Device Marking for that device.
- (6) Lead finish/Ball material - Orderable Devices may have multiple material finish options. Finish options are separated by a vertical ruled line. Lead finish/Ball material values may wrap to two lines if the finish value exceeds the maximum column width.

Important Information and Disclaimer:The information provided on this page represents TI's knowledge and belief as of the date that it is provided. TI bases its knowledge and belief on information provided by third parties, and makes no representation or warranty as to the accuracy of such information. Efforts are underway to better integrate information from third parties. TI has taken and continues to take reasonable steps to provide representative and accurate information but may not have conducted destructive testing or chemical analysis on incoming materials and chemicals. TI and TI suppliers consider certain information to be proprietary, and thus CAS numbers and other limited information may not be available for release.

In no event shall TI's liability arising out of such information exceed the total purchase price of the TI part(s) at issue in this document sold by TI to Customer on an annual basis.

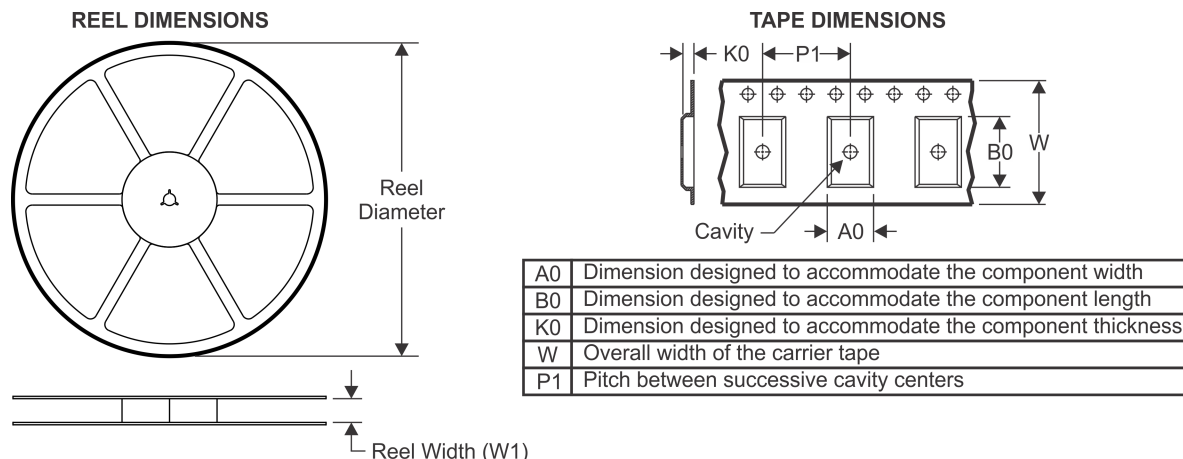
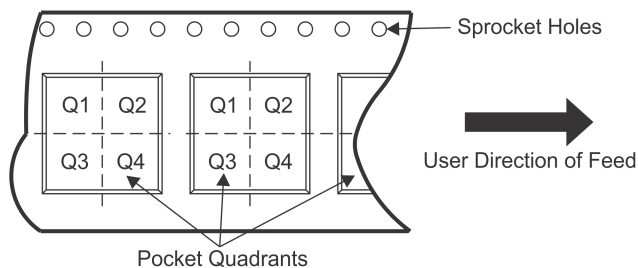
TAPE AND REEL INFORMATION

QUADRANT ASSIGNMENTS FOR PIN 1 ORIENTATION IN TAPE

*All dimensions are nominal

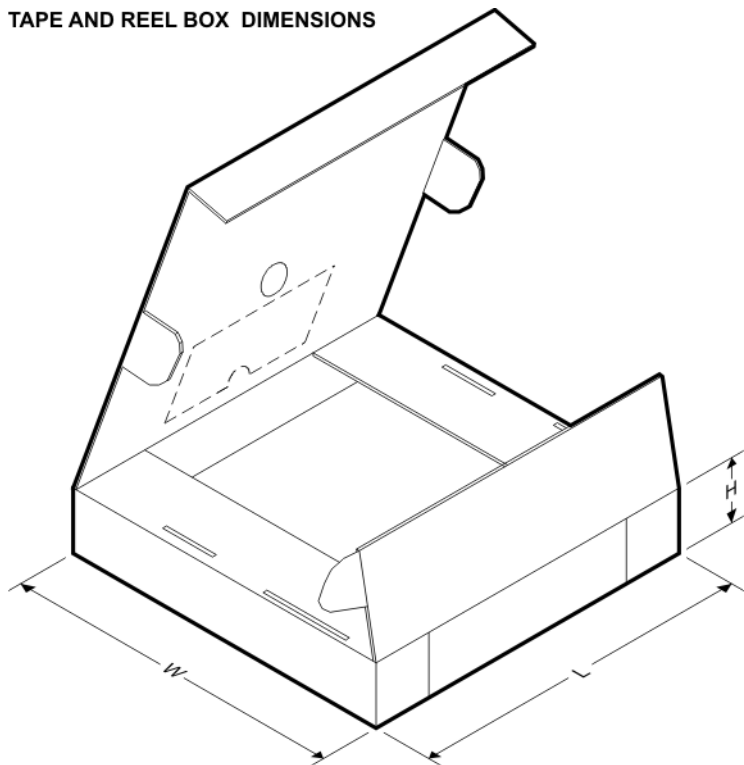
Device	Package Type	Package Drawing	Pins	SPQ	Reel Diameter (mm)	Reel Width W1 (mm)	A0 (mm)	B0 (mm)	K0 (mm)	P1 (mm)	W (mm)	Pin1 Quadrant
LMC6484AIMX	SOIC	D	14	2500	330.0	16.4	6.5	9.35	2.3	8.0	16.0	Q1
LMC6484AIMX/NOPB	SOIC	D	14	2500	330.0	16.4	6.5	9.35	2.3	8.0	16.0	Q1
LMC6484IMX	SOIC	D	14	2500	330.0	16.4	6.5	9.35	2.3	8.0	16.0	Q1
LMC6484IMX/NOPB	SOIC	D	14	2500	330.0	16.4	6.5	9.35	2.3	8.0	16.0	Q1

TAPE AND REEL BOX DIMENSIONS

*All dimensions are nominal

Device	Package Type	Package Drawing	Pins	SPQ	Length (mm)	Width (mm)	Height (mm)
LMC6484AIMX	SOIC	D	14	2500	367.0	367.0	35.0
LMC6484AIMX/NOPB	SOIC	D	14	2500	367.0	367.0	35.0
LMC6484IMX	SOIC	D	14	2500	367.0	367.0	35.0
LMC6484IMX/NOPB	SOIC	D	14	2500	367.0	367.0	35.0

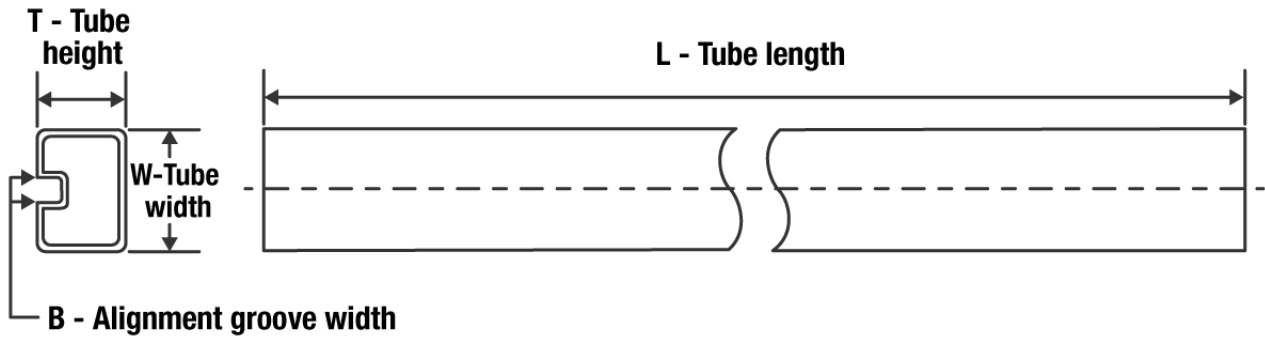
TUBE

*All dimensions are nominal

Device	Package Name	Package Type	Pins	SPQ	L (mm)	W (mm)	T (μm)	B (mm)
LMC6484AIM	D	SOIC	14	55	495	8	4064	3.05
LMC6484AIM	D	SOIC	14	55	495	8	4064	3.05
LMC6484AIM/NOPB	D	SOIC	14	55	495	8	4064	3.05
LMC6484AIN/NOPB	N	PDIP	14	25	502	14	11938	4.32
LMC6484IM	D	SOIC	14	55	495	8	4064	3.05
LMC6484IM	D	SOIC	14	55	495	8	4064	3.05
LMC6484IM/NOPB	D	SOIC	14	55	495	8	4064	3.05
LMC6484IN/NOPB	N	PDIP	14	25	502	14	11938	4.32

D (R-PDSO-G14)

PLASTIC SMALL OUTLINE



- NOTES:
- A. All linear dimensions are in millimeters.
 - B. This drawing is subject to change without notice.
 - C. Publication IPC-7351 is recommended for alternate designs.
 - D. Laser cutting apertures with trapezoidal walls and also rounding corners will offer better paste release. Customers should contact their board assembly site for stencil design recommendations. Refer to IPC-7525 for other stencil recommendations.
 - E. Customers should contact their board fabrication site for solder mask tolerances between and around signal pads.

N (R-PDIP-T**)

PLASTIC DUAL-IN-LINE PACKAGE

16 PINS SHOWN



- NOTES:
- A. All linear dimensions are in inches (millimeters).
 - B. This drawing is subject to change without notice.
 - C Falls within JEDEC MS-001, except 18 and 20 pin minimum body length (Dim A).
 - D The 20 pin end lead shoulder width is a vendor option, either half or full width.

4040049/E 12/2002

IMPORTANT NOTICE AND DISCLAIMER

TI PROVIDES TECHNICAL AND RELIABILITY DATA (INCLUDING DATA SHEETS), DESIGN RESOURCES (INCLUDING REFERENCE DESIGNS), APPLICATION OR OTHER DESIGN ADVICE, WEB TOOLS, SAFETY INFORMATION, AND OTHER RESOURCES "AS IS" AND WITH ALL FAULTS, AND DISCLAIMS ALL WARRANTIES, EXPRESS AND IMPLIED, INCLUDING WITHOUT LIMITATION ANY IMPLIED WARRANTIES OF MERCHANTABILITY, FITNESS FOR A PARTICULAR PURPOSE OR NON-INFRINGEMENT OF THIRD PARTY INTELLECTUAL PROPERTY RIGHTS.

These resources are intended for skilled developers designing with TI products. You are solely responsible for (1) selecting the appropriate TI products for your application, (2) designing, validating and testing your application, and (3) ensuring your application meets applicable standards, and any other safety, security, regulatory or other requirements.

These resources are subject to change without notice. TI grants you permission to use these resources only for development of an application that uses the TI products described in the resource. Other reproduction and display of these resources is prohibited. No license is granted to any other TI intellectual property right or to any third party intellectual property right. TI disclaims responsibility for, and you will fully indemnify TI and its representatives against, any claims, damages, costs, losses, and liabilities arising out of your use of these resources.

TI's products are provided subject to [TI's Terms of Sale](#) or other applicable terms available either on ti.com or provided in conjunction with such TI products. TI's provision of these resources does not expand or otherwise alter TI's applicable warranties or warranty disclaimers for TI products.

TI objects to and rejects any additional or different terms you may have proposed.

Mailing Address: Texas Instruments, Post Office Box 655303, Dallas, Texas 75265
Copyright © 2022, Texas Instruments Incorporated