

## FEATURES

- **Controlled Baseline**
  - One Assembly
  - One Test Site
  - One Fabrication Site
- **Extended Temperature Performance of up to  $-55^{\circ}\text{C}$  to  $125^{\circ}\text{C}$**
- **Enhanced Diminishing Manufacturing Sources (DMS) Support**
- **Enhanced Product-Change Notification**
- **Qualification Pedigree <sup>(1)</sup>**
- **RS-232 Bus-Pin ESD Protection Exceeds  $\pm 15$  kV Using Human-Body Model (HBM)**
- **Meets or Exceeds the Requirements of TIA/EIA-232-F and ITU v.28 Standards**
- **Operates With 3-V to 5.5-V  $V_{CC}$  Supply**
- **Operates up to 250 kbit/s**
- **Two Drivers and Two Receivers**
- **Low Standby Current . . . 1  $\mu\text{A}$  Typical**
- **External Capacitors . . .  $4 \times 0.1 \mu\text{F}$**
- **Accepts 5-V Logic Input With 3.3-V Supply**
- **Alternative High-Speed Pin-Compatible Device (1 Mbit/s)**
  - SNx5C3223

- (1) Component qualification in accordance with JEDEC and industry standards to ensure reliable operation over an extended temperature range. This includes, but is not limited to, Highly Accelerated Stress Test (HAST) or biased 85/85, temperature cycle, autoclave or unbiased HAST, electromigration, bond intermetallic life, and mold compound life. Such qualification testing should not be viewed as justifying use of this component beyond specified performance and environmental limits.

## APPLICATIONS

- **Battery-Powered Systems**
- **PDA's**
- **Notebooks**
- **Laptops**
- **Palmtop PCs**
- **Hand-Held Equipment**

DB, DW, OR PW PACKAGE  
(TOP VIEW)

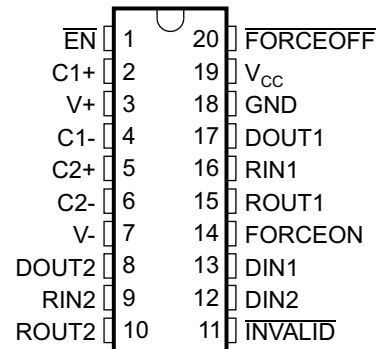

## DESCRIPTION/ORDERING INFORMATION

The MAX3223 consists of two line drivers, two line receivers, and a dual charge-pump circuit with  $\pm 15$ -kV ESD protection pin to pin (serial-port connection pins, including GND). The device meets the requirements of TIA/EIA-232-F and provides the electrical interface between an asynchronous communication controller and the serial-port connector. The charge pump and four small external capacitors allow operation from a single 3-V to 5.5-V supply. The device operates at typical data signaling rates up to 250 kbit/s and a maximum of 30-V/ $\mu\text{s}$  driver output slew rate.

### ORDERING INFORMATION

$T_A$	PACKAGE <sup>(1)</sup>		ORDERABLE PART NUMBER	TOP-SIDE MARKING
$-55^{\circ}\text{C}$ to $125^{\circ}\text{C}$	SOIC – DW	Reel of 2000	MAX3223MDWREP <sup>(2)</sup>	MAX3223M
	SSOP – DB	Reel of 2000	MAX3223MDBREP	MB223M
	TSSOP – PW	Reel of 2000	MAX3223MPWREP <sup>(2)</sup>	MB223M

(1) Package drawings, standard packing quantities, thermal data, symbolization, and PCB design guidelines are available at [www.ti.com/sc/package](http://www.ti.com/sc/package).

(2) Product Preview



Please be aware that an important notice concerning availability, standard warranty, and use in critical applications of Texas Instruments semiconductor products and disclaimers thereto appears at the end of this data sheet.

**DESCRIPTION/ORDERING INFORMATION (CONTINUED)**

Flexible control options for power management are available when the serial port is inactive. The auto-powerdown feature functions when FORCEON is low and FORCEOFF is high. During this mode of operation, if the device does not sense a valid RS-232 signal, the driver outputs are disabled. If FORCEOFF is set low and EN is high, both drivers and receivers are shut off, and the supply current is reduced to 1 µA. Disconnecting the serial port or turning off the peripheral drivers causes auto-powerdown to occur. Auto-powerdown can be disabled when FORCEON and FORCEOFF are high. With auto-powerdown enabled, the device is activated automatically when a valid signal is applied to any receiver input. The INVALID output is used to notify the user if an RS-232 signal is present at any receiver input. INVALID is high (valid data) if any receiver input voltage is greater than 2.7 V or less than -2.7 V, or has been between -0.3 V and 0.3 V for less than 30 µs. INVALID is low (invalid data) if the receiver input voltage is between -0.3 V and 0.3 V for more than 30 µs. See Figure 4 for receiver input levels.

**FUNCTION TABLES**

**EACH DRIVER<sup>(1)</sup>**

INPUTS				OUTPUT DOUT	DRIVER STATUS
DIN	FORCEON	FORCEOFF	VALID RIN RS-232 LEVEL		
X	X	L	X	Z	Powered off
L	H	H	X	H	Normal operation with auto-powerdown disabled
H	H	H	X	L	
L	L	H	Yes	H	Normal operation with auto-powerdown enabled
H	L	H	Yes	L	
L	L	H	No	Z	Powered off by auto-powerdown feature
H	L	H	No	Z	

(1) H = high level, L = low level, X = irrelevant, Z = high impedance

**EACH RECEIVER<sup>(1)</sup>**

INPUTS			OUTPUT ROUT
RIN	EN	VALID RIN RS-232 LEVEL	
L	L	X	H
H	L	X	L
X	H	X	Z
Open	L	No	H

(1) H = high level, L = low level, X = irrelevant,  
Z = high impedance (off),  
Open = input disconnected or connected driver off

LOGIC DIAGRAM (POSITIVE LOGIC)

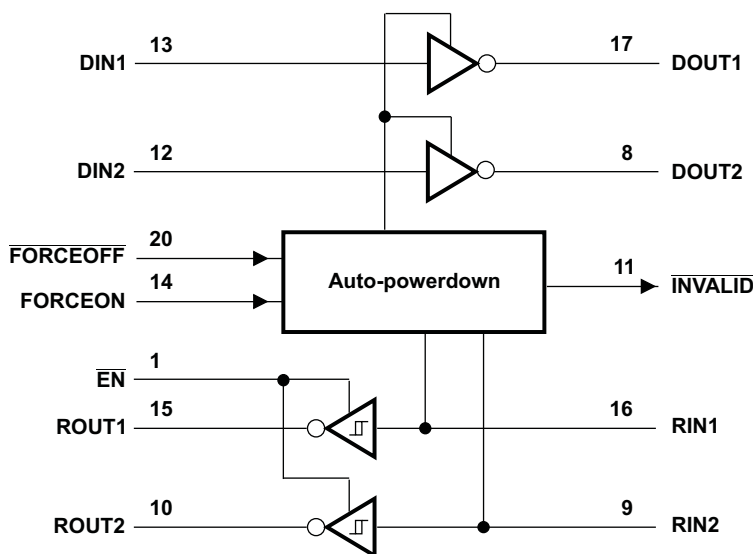

**Absolute Maximum Ratings**<sup>(1)</sup>

over operating free-air temperature range (unless otherwise noted)

		MIN	MAX	UNIT
V <sub>CC</sub>	Supply voltage range	-0.3	6	V
V+	Positive-output supply voltage range <sup>(2)</sup>	-0.3	7	V
V-	Negative-output supply voltage range <sup>(2)</sup>	0.3	-7	V
V+ - V-	Supply voltage difference <sup>(2)</sup>		13	V
V <sub>I</sub>	Input voltage range	Driver (FORCEOFF, FORCEON, EN)		V
		Receiver		
V <sub>O</sub>	Output voltage range	Driver		V
		Receiver (INVALID)		
θ <sub>JA</sub>	Package thermal impedance <sup>(3)(4)</sup>	DB package		°C/W
		DW package		
		PW package		
T <sub>J</sub>	Operating virtual junction temperature		150	°C
T <sub>stg</sub>	Storage temperature range	-65	150	°C

- (1) Stresses beyond those listed under "absolute maximum ratings" may cause permanent damage to the device. These are stress ratings only, and functional operation of the device at these or any other conditions beyond those indicated under "recommended operating conditions" is not implied. Exposure to absolute-maximum-rated conditions for extended periods may affect device reliability.
- (2) All voltages are with respect to network GND.
- (3) Maximum power dissipation is a function of T<sub>J(max)</sub>, θ<sub>JA</sub>, and T<sub>A</sub>. The maximum allowable power dissipation at any allowable ambient temperature is P<sub>D</sub> = (T<sub>J(max)</sub> - T<sub>A</sub>)/θ<sub>JA</sub>. Operating at the absolute maximum T<sub>J</sub> of 150°C can affect reliability.
- (4) The package thermal impedance is calculated in accordance with JESD 51-7.

**MAX3223-EP**  
**3-V TO 5.5-V MULTICHANNEL RS-232 LINE DRIVER/RECEIVER**  
**WITH  $\pm 15$ -kV ESD PROTECTION**

SGLS368–SEPTEMBER 2006

**Recommended Operating Conditions<sup>(1)</sup>**

See [Figure 6](#)

			MIN	NOM	MAX	UNIT
Supply voltage		$V_{CC} = 3.3\text{ V}$	3	3.3	3.6	V
		$V_{CC} = 5\text{ V}$	4.5	5	5.5	
$V_{IH}$	Driver and control high-level input voltage	DIN, $\overline{EN}$ , $\overline{FORCEOFF}$ , FORCEON	$V_{CC} = 3.3\text{ V}$	2		V
			$V_{CC} = 5\text{ V}$	2.4		
$V_{IL}$	Driver and control low-level input voltage	DIN, $\overline{EN}$ , $\overline{FORCEOFF}$ , FORCEON			0.8	V
$V_I$	Driver and control input voltage	DIN, $\overline{EN}$ , $\overline{FORCEOFF}$ , FORCEON	0	5.5		V
	Receiver input voltage		-25	25		V
$T_A$	Operating free-air temperature		-55	125		$^{\circ}\text{C}$

(1) Test conditions are C1–C4 = 0.1  $\mu\text{F}$  at  $V_{CC} = 3.3\text{ V} \pm 0.3\text{ V}$ ; C1 = 0.047  $\mu\text{F}$ , C2–C4 = 0.33  $\mu\text{F}$  at  $V_{CC} = 5\text{ V} \pm 0.5\text{ V}$ .

**Electrical Characteristics<sup>(1)</sup>**

over recommended ranges of supply voltage and operating free-air temperature (unless otherwise noted) (see [Figure 6](#))

PARAMETER		TEST CONDITIONS		MIN	TYP <sup>(2)</sup>	MAX	UNIT
$I_I$	Input leakage current	$\overline{EN}$ , $\overline{FORCEOFF}$ , FORCEON			$\pm 0.01$	$\pm 1$	$\mu\text{A}$
$I_{CC}$	Supply current	Auto-powerdown disabled	$V_{CC} = 3.3\text{ V}$ or $5\text{ V}$ , $T_A = 25^{\circ}\text{C}$	No load, $\overline{FORCEOFF}$ and FORCEON at $V_{CC}$	0.3	2	mA
		Powered off		No load, $\overline{FORCEOFF}$ at GND	1	20	$\mu\text{A}$
		Auto-powerdown enabled		No load, $\overline{FORCEOFF}$ at $V_{CC}$ , FORCEON at GND, All RIN are open or grounded	1	20	

(1) Test conditions are C1–C4 = 0.1  $\mu\text{F}$  at  $V_{CC} = 3.3\text{ V} \pm 0.3\text{ V}$ ; C1 = 0.047  $\mu\text{F}$ , C2–C4 = 0.33  $\mu\text{F}$  at  $V_{CC} = 5\text{ V} \pm 0.5\text{ V}$ .

(2) All typical values are at  $V_{CC} = 3.3\text{ V}$  or  $V_{CC} = 5\text{ V}$ , and  $T_A = 25^{\circ}\text{C}$ .

## DRIVER SECTION

### Electrical Characteristics<sup>(1)</sup>

over recommended ranges of supply voltage and operating free-air temperature (unless otherwise noted) (see [Figure 6](#))

PARAMETER		TEST CONDITIONS	MIN <sup>(2)</sup>	TYP <sup>(3)</sup>	MAX	UNIT
V <sub>OH</sub>	High-level output voltage	DOUT at R <sub>L</sub> = 3 k $\Omega$ to GND	5	5.4		V
V <sub>OL</sub>	Low-level output voltage	DOUT at R <sub>L</sub> = 3 k $\Omega$ to GND	V <sub>CC</sub> = 5 V	-5	-5.4	V
			V <sub>CC</sub> = 3.3 V	-4.9		
I <sub>IH</sub>	High-level input current	V <sub>I</sub> = V <sub>CC</sub>		$\pm 0.01$	$\pm 1$	$\mu$ A
I <sub>IL</sub>	Low-level input current	V <sub>I</sub> at GND		$\pm 0.01$	$\pm 1$	$\mu$ A
I <sub>OS</sub>	Short-circuit output current <sup>(4)</sup>	V <sub>CC</sub> = 3.6 V, V <sub>O</sub> = 0 V		$\pm 35$	$\pm 60$	mA
		V <sub>CC</sub> = 5.5 V, V <sub>O</sub> = 0 V		$\pm 35$	$\pm 60$	
r <sub>o</sub>	Output resistance	V <sub>CC</sub> , V <sub>+</sub> , and V <sub>-</sub> = 0 V, V <sub>O</sub> = $\pm 2$ V	300	10M		$\Omega$
I <sub>OZ</sub>	Output leakage current	FORCEOFF = GND	V <sub>CC</sub> = 3 V to 3.6 V, V <sub>O</sub> = $\pm 12$ V		$\pm 25$	$\mu$ A
			V <sub>CC</sub> = 4.5 V to 5.5 V, V <sub>O</sub> = $\pm 10$ V		$\pm 25$	

(1) Test conditions are C1–C4 = 0.1  $\mu$ F at V<sub>CC</sub> = 3.3 V  $\pm$  0.3 V; C1 = 0.047  $\mu$ F, C2–C4 = 0.33  $\mu$ F at V<sub>CC</sub> = 5 V  $\pm$  0.5 V.

(2) The minimum reading of -4.9 V at V<sub>CC</sub> = 3.3 V falls outside the TIA/EIA-232 Standard.

(3) All typical values are at V<sub>CC</sub> = 3.3 V or V<sub>CC</sub> = 5 V, and T<sub>A</sub> = 25°C.

(4) Short-circuit durations should be controlled to prevent exceeding the device absolute power dissipation ratings, and not more than one output should be shorted at a time.

### Switching Characteristics<sup>(1)</sup>

over recommended ranges of supply voltage and operating free-air temperature (unless otherwise noted) (see [Figure 6](#))

PARAMETER		TEST CONDITIONS	MIN	TYP <sup>(2)</sup>	MAX	UNIT
	Maximum data rate	C <sub>L</sub> = 1000 pF, One DOUT switching, R <sub>L</sub> = 3 k $\Omega$ , See <a href="#">Figure 1</a>	250			kbit/s
t <sub>sk(p)</sub>	Pulse skew <sup>(3)</sup>	C <sub>L</sub> = 150 pF to 2500 pF, See <a href="#">Figure 2</a>		100		ns
SR(tr)	Slew rate, transition region (see <a href="#">Figure 1</a> )	V <sub>CC</sub> = 3.3 V, R <sub>L</sub> = 3 k $\Omega$ to 7 k $\Omega$	C <sub>L</sub> = 150 pF to 1000 pF	6	30	V/ $\mu$ s
			C <sub>L</sub> = 150 pF to 2500 pF	4	30	

(1) Test conditions are C1–C4 = 0.1  $\mu$ F at V<sub>CC</sub> = 3.3 V  $\pm$  0.3 V; C1 = 0.047  $\mu$ F, C2–C4 = 0.33  $\mu$ F at V<sub>CC</sub> = 5 V  $\pm$  0.5 V.

(2) All typical values are at V<sub>CC</sub> = 3.3 V or V<sub>CC</sub> = 5 V, and T<sub>A</sub> = 25°C.

(3) Pulse skew is defined as |t<sub>PLH</sub> - t<sub>PHL</sub>| of each channel of the same device.

# MAX3223-EP

## 3-V TO 5.5-V MULTICHANNEL RS-232 LINE DRIVER/RECEIVER

### WITH $\pm 15$ -kV ESD PROTECTION

SGLS368–SEPTEMBER 2006

## RECEIVER SECTION

### Electrical Characteristics<sup>(1)</sup>

over recommended ranges of supply voltage and operating free-air temperature (unless otherwise noted) (see [Figure 6](#))

PARAMETER		TEST CONDITIONS	MIN	TYP <sup>(2)</sup>	MAX	UNIT
V <sub>OH</sub>	High-level output voltage	I <sub>OH</sub> = -1 mA	V <sub>CC</sub> - 0.6	V <sub>CC</sub> - 0.1		V
V <sub>OL</sub>	Low-level output voltage	I <sub>OL</sub> = 1.6 mA			0.4	V
V <sub>IT+</sub>	Positive-going input threshold voltage	V <sub>CC</sub> = 3.3 V		1.6	2.4	V
		V <sub>CC</sub> = 5 V		1.9	2.4	
V <sub>IT-</sub>	Negative-going input threshold voltage	V <sub>CC</sub> = 3.3 V	0.6	1.1		V
		V <sub>CC</sub> = 5 V	0.8	1.4		
V <sub>hys</sub>	Input hysteresis (V <sub>IT+</sub> - V <sub>IT-</sub> )			0.5		V
I <sub>OZ</sub>	Output leakage current	$\overline{EN} = V_{CC}$		$\pm 0.05$	$\pm 10$	$\mu$ A
r <sub>i</sub>	Input resistance	V <sub>I</sub> = $\pm 3$ V to $\pm 16$ V	3	5	8.3	k $\Omega$

(1) Test conditions are C1–C4 = 0.1  $\mu$ F at V<sub>CC</sub> = 3.3 V  $\pm$  0.3 V; C1 = 0.047  $\mu$ F, C2–C4 = 0.33  $\mu$ F at V<sub>CC</sub> = 5 V  $\pm$  0.5 V.

(2) All typical values are at V<sub>CC</sub> = 3.3 V or V<sub>CC</sub> = 5 V, and T<sub>A</sub> = 25°C.

### Switching Characteristics<sup>(1)</sup>

over recommended ranges of supply voltage and operating free-air temperature (unless otherwise noted)

PARAMETER		TEST CONDITIONS	TYP <sup>(2)</sup>	UNIT
t <sub>PLH</sub>	Propagation delay time, low- to high-level output	C <sub>L</sub> = 150 pF, See <a href="#">Figure 3</a>	150	ns
t <sub>PHL</sub>	Propagation delay time, high- to low-level output	C <sub>L</sub> = 150 pF, See <a href="#">Figure 3</a>	150	ns
t <sub>en</sub>	Output enable time	C <sub>L</sub> = 150 pF, R <sub>L</sub> = 3 k $\Omega$ , See <a href="#">Figure 4</a>	200	ns
t <sub>dis</sub>	Output disable time	C <sub>L</sub> = 150 pF, R <sub>L</sub> = 3 k $\Omega$ , See <a href="#">Figure 4</a>	200	ns
t <sub>sk(p)</sub>	Pulse skew <sup>(3)</sup>	See <a href="#">Figure 3</a>	50	ns

(1) Test conditions are C1–C4 = 0.1  $\mu$ F at V<sub>CC</sub> = 3.3 V  $\pm$  0.3 V; C1 = 0.047  $\mu$ F, C2–C4 = 0.33  $\mu$ F at V<sub>CC</sub> = 5 V  $\pm$  0.5 V.

(2) All typical values are at V<sub>CC</sub> = 3.3 V or V<sub>CC</sub> = 5 V, and T<sub>A</sub> = 25°C.

(3) Pulse skew is defined as |t<sub>PLH</sub> - t<sub>PHL</sub>| of each channel of the same device.

## AUTO-POWERDOWN SECTION

### Electrical Characteristics

over recommended ranges of supply voltage and operating free-air temperature (unless otherwise noted) (see [Figure 5](#))

PARAMETER		TEST CONDITIONS		MIN	MAX	UNIT
$V_{T+(valid)}$	Receiver input threshold for $\overline{INVALID}$ high-level output voltage	FORCEON = GND,	$\overline{FORCEOFF} = V_{CC}$		2.7	V
$V_{T-(valid)}$	Receiver input threshold for $\overline{INVALID}$ high-level output voltage	FORCEON = GND,	$\overline{FORCEOFF} = V_{CC}$	-2.7		V
$V_{T(invalid)}$	Receiver input threshold for $\overline{INVALID}$ low-level output voltage	FORCEON = GND,	$\overline{FORCEOFF} = V_{CC}$	-0.2	0.3	V
$V_{OH}$	$\overline{INVALID}$ high-level output voltage	$I_{OH} = 1\text{ mA}$ , $\overline{FORCEOFF} = V_{CC}$	FORCEON = GND,	$V_{CC} - 0.6$		V
$V_{OL}$	$\overline{INVALID}$ low-level output voltage	$I_{OL} = 1.6\text{ mA}$ , $\overline{FORCEOFF} = V_{CC}$	FORCEON = GND,		0.4	V

### Switching Characteristics

over recommended ranges of supply voltage and operating free-air temperature (unless otherwise noted) (see [Figure 5](#))

PARAMETER		TYP (1)	UNIT
$t_{valid}$	Propagation delay time, low- to high-level output	1	$\mu\text{s}$
$t_{invalid}$	Propagation delay time, high- to low-level output	30	$\mu\text{s}$
$t_{en}$	Supply enable time	100	$\mu\text{s}$

(1) All typical values are at  $V_{CC} = 3.3\text{ V}$  or  $V_{CC} = 5\text{ V}$ , and  $T_A = 25^\circ\text{C}$ .

**PARAMETER MEASUREMENT INFORMATION**

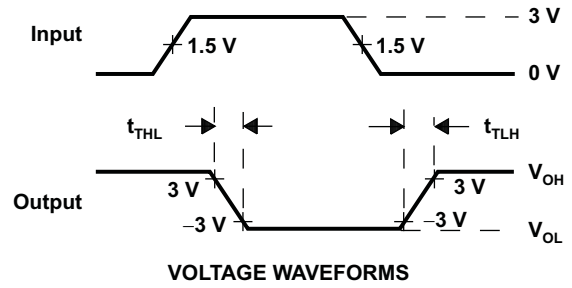
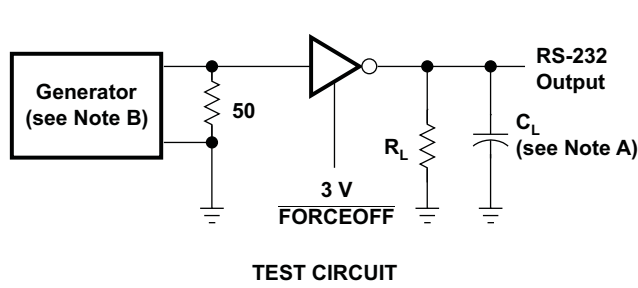

NOTES: A.  $C_L$  includes probe and jig capacitance.  
 B. The pulse generator has the following characteristics: PRR = 250 kbit/s,  $Z_0 = 50 \Omega$ , 50% duty cycle,  $t_r \leq 10$  ns,  $t_f \leq 10$  ns.

**Figure 1. Driver Slew Rate**

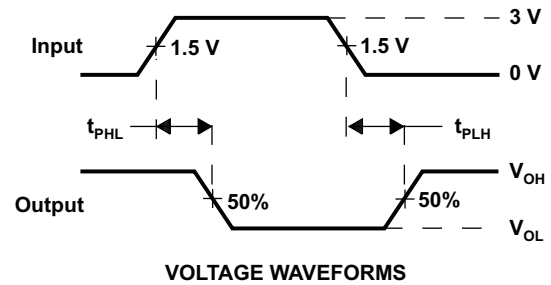
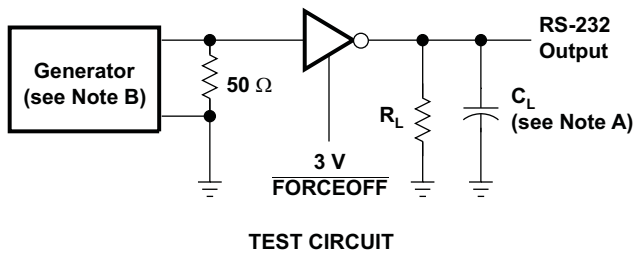

NOTES: A.  $C_L$  includes probe and jig capacitance.  
 B. The pulse generator has the following characteristics: PRR = 250 kbit/s,  $Z_0 = 50 \Omega$ , 50% duty cycle,  $t_r \leq 10$  ns,  $t_f \leq 10$  ns.

**Figure 2. Driver Pulse Skew**

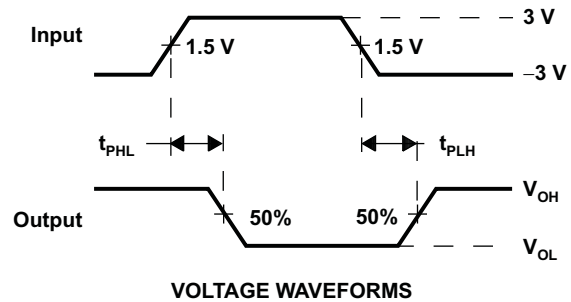
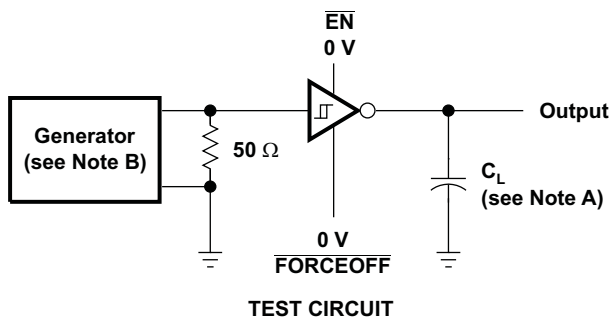

NOTES: A.  $C_L$  includes probe and jig capacitance.  
 B. The pulse generator has the following characteristics:  $Z_0 = 50 \Omega$ , 50% duty cycle,  $t_r \leq 10$  ns,  $t_f \leq 10$  ns.

**Figure 3. Receiver Propagation Delay Times**

PARAMETER MEASUREMENT INFORMATION (continued)

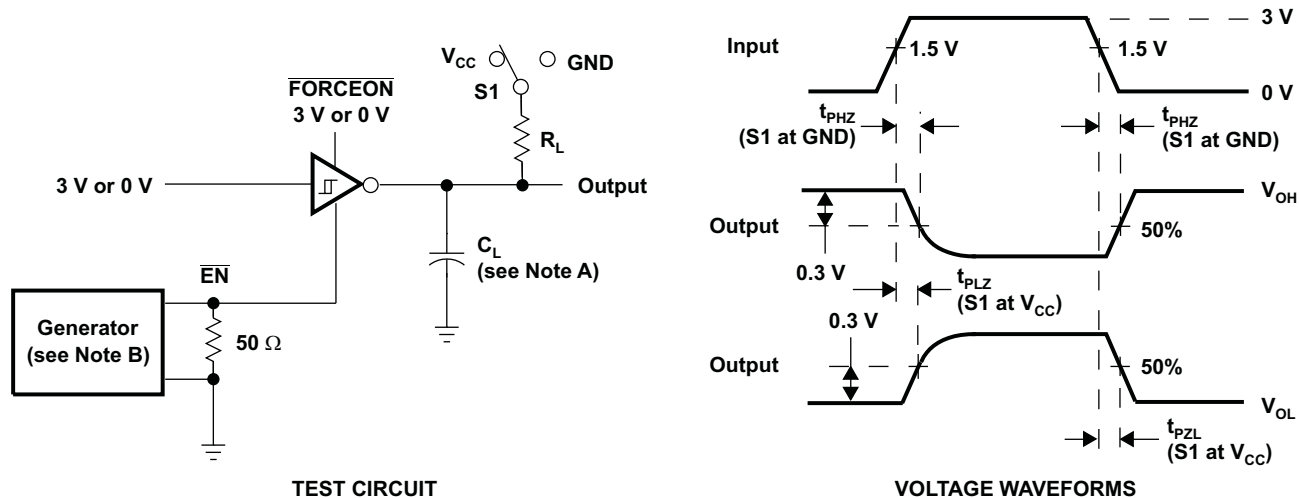

- NOTES: A.  $C_L$  includes probe and jig capacitance.  
B. The pulse generator has the following characteristics:  $Z_o = 50 \Omega$ , 50% duty cycle,  $t_r \leq 10$  ns,  $t_f \leq 10$  ns.

Figure 4. Receiver Enable and Disable Times

PARAMETER MEASUREMENT INFORMATION (continued)

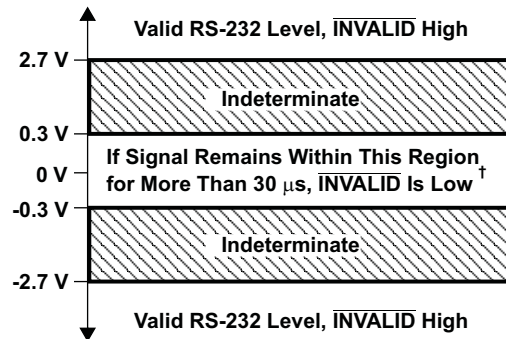
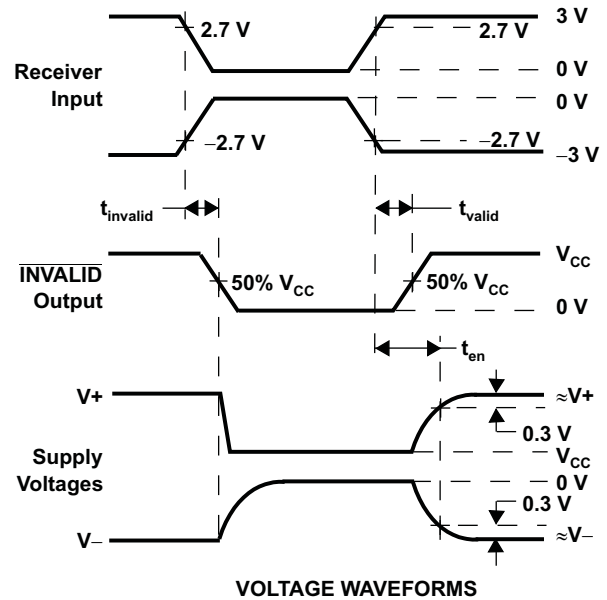
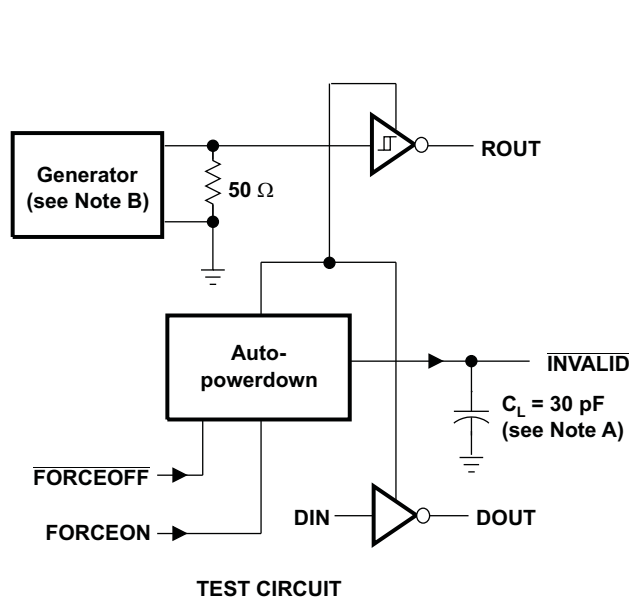

<sup>†</sup> Auto-powerdown disables drivers and reduces supply current to  $1$   $\mu\text{A}$ .

- NOTES: A.  $C_L$  includes probe and jig capacitance.  
 B. The pulse generator has the following characteristics: PRR = 5 kbit/s,  $Z_O = 50$   $\Omega$ , 50% duty cycle,  $t_r \leq 10$  ns,  $t_f \leq 10$  ns.

Figure 5.  $\overline{\text{INVALID}}$  Propagation Delay Times and Supply Enabling Time

APPLICATION INFORMATION

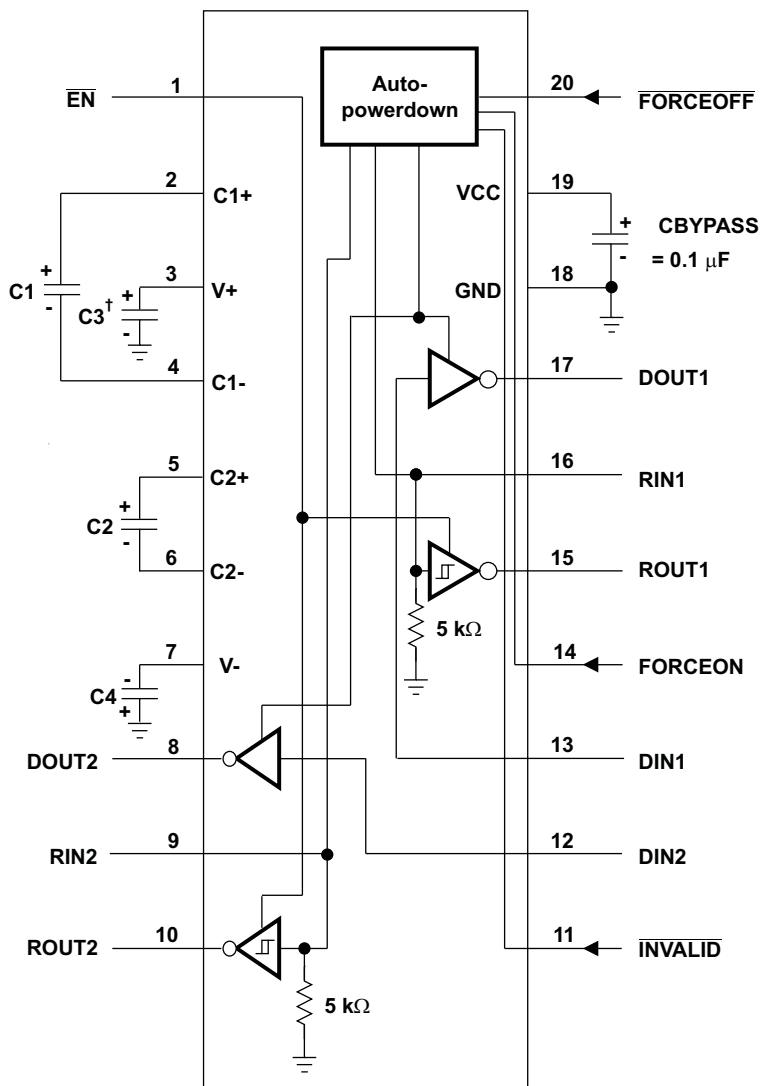

<sup>†</sup> C3 can be connected to V<sub>CC</sub> or GND.

NOTES: A. Resistor values shown are nominal.

B. Non polarized ceramic capacitors are acceptable. If polarized tantalum or electrolytic capacitors are used, they should be connected as shown.

V<sub>CC</sub> vs CAPACITOR VALUES

V <sub>CC</sub>	C1	C2, C3, C4
3.3 V ± 0.3 V	0.1 μF	0.1 μF
5 V ± 0.5 V	0.047 μF	0.33 μF
3 V to 5.5 V	0.1 μF	0.47 μF

Figure 6. Typical Operating Circuit and Capacitor Values

**PACKAGING INFORMATION**

Orderable Device	Status (1)	Package Type	Package Drawing	Pins	Package Qty	Eco Plan (2)	Lead finish/ Ball material (6)	MSL Peak Temp (3)	Op Temp (°C)	Device Marking (4/5)	Samples
MAX3223MDBREP	ACTIVE	SSOP	DB	20	2000	RoHS & Green	NIPDAU	Level-1-260C-UNLIM	-55 to 125	MB3223M	<a href="#">Samples</a>
V62/06635-01XE	ACTIVE	SSOP	DB	20	2000	RoHS & Green	NIPDAU	Level-1-260C-UNLIM	-55 to 125	MB3223M	<a href="#">Samples</a>

(1) The marketing status values are defined as follows:

**ACTIVE:** Product device recommended for new designs.

**LIFEBUY:** TI has announced that the device will be discontinued, and a lifetime-buy period is in effect.

**NRND:** Not recommended for new designs. Device is in production to support existing customers, but TI does not recommend using this part in a new design.

**PREVIEW:** Device has been announced but is not in production. Samples may or may not be available.

**OBSOLETE:** TI has discontinued the production of the device.

(2) **RoHS:** TI defines "RoHS" to mean semiconductor products that are compliant with the current EU RoHS requirements for all 10 RoHS substances, including the requirement that RoHS substance do not exceed 0.1% by weight in homogeneous materials. Where designed to be soldered at high temperatures, "RoHS" products are suitable for use in specified lead-free processes. TI may reference these types of products as "Pb-Free".

**RoHS Exempt:** TI defines "RoHS Exempt" to mean products that contain lead but are compliant with EU RoHS pursuant to a specific EU RoHS exemption.

**Green:** TI defines "Green" to mean the content of Chlorine (Cl) and Bromine (Br) based flame retardants meet JS709B low halogen requirements of <=1000ppm threshold. Antimony trioxide based flame retardants must also meet the <=1000ppm threshold requirement.

(3) MSL, Peak Temp. - The Moisture Sensitivity Level rating according to the JEDEC industry standard classifications, and peak solder temperature.

(4) There may be additional marking, which relates to the logo, the lot trace code information, or the environmental category on the device.

(5) Multiple Device Markings will be inside parentheses. Only one Device Marking contained in parentheses and separated by a "~" will appear on a device. If a line is indented then it is a continuation of the previous line and the two combined represent the entire Device Marking for that device.

(6) Lead finish/Ball material - Orderable Devices may have multiple material finish options. Finish options are separated by a vertical ruled line. Lead finish/Ball material values may wrap to two lines if the finish value exceeds the maximum column width.

**Important Information and Disclaimer:**The information provided on this page represents TI's knowledge and belief as of the date that it is provided. TI bases its knowledge and belief on information provided by third parties, and makes no representation or warranty as to the accuracy of such information. Efforts are underway to better integrate information from third parties. TI has taken and continues to take reasonable steps to provide representative and accurate information but may not have conducted destructive testing or chemical analysis on incoming materials and chemicals. TI and TI suppliers consider certain information to be proprietary, and thus CAS numbers and other limited information may not be available for release.

In no event shall TI's liability arising out of such information exceed the total purchase price of the TI part(s) at issue in this document sold by TI to Customer on an annual basis.

**OTHER QUALIFIED VERSIONS OF MAX3223-EP :**

- Catalog: [MAX3223](#)

## NOTE: Qualified Version Definitions:

- Catalog - TI's standard catalog product

## TAPE AND REEL INFORMATION

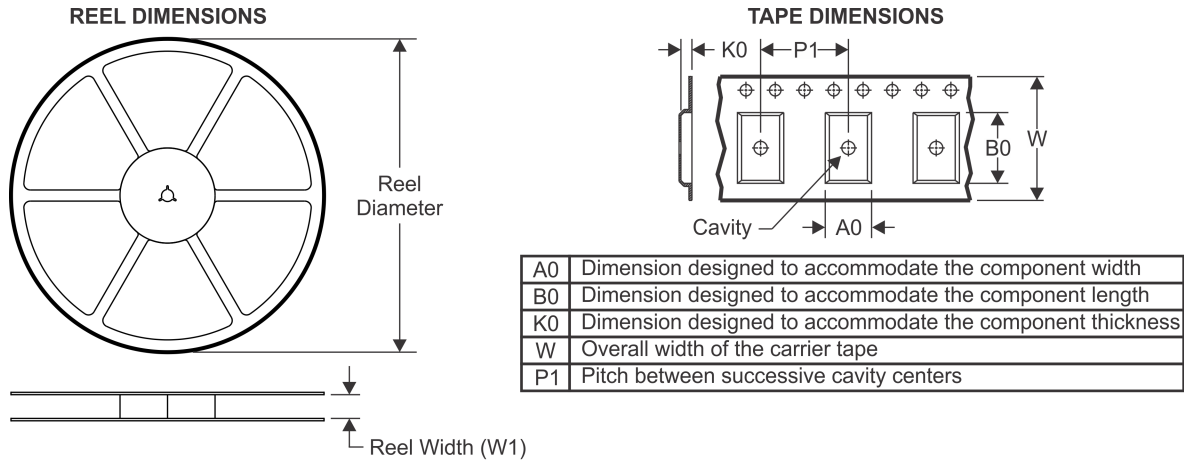

### QUADRANT ASSIGNMENTS FOR PIN 1 ORIENTATION IN TAPE



\*All dimensions are nominal

Device	Package Type	Package Drawing	Pins	SPQ	Reel Diameter (mm)	Reel Width W1 (mm)	A0 (mm)	B0 (mm)	K0 (mm)	P1 (mm)	W (mm)	Pin1 Quadrant
MAX3223MDBREP	SSOP	DB	20	2000	330.0	16.4	8.2	7.5	2.5	12.0	16.0	Q1

TAPE AND REEL BOX DIMENSIONS



\*All dimensions are nominal

Device	Package Type	Package Drawing	Pins	SPQ	Length (mm)	Width (mm)	Height (mm)
MAX3223MDBREP	SSOP	DB	20	2000	853.0	449.0	35.0

# DB0020A



# PACKAGE OUTLINE

## SSOP - 2 mm max height

SMALL OUTLINE PACKAGE



4214851/B 08/2019

### NOTES:

1. All linear dimensions are in millimeters. Any dimensions in parenthesis are for reference only. Dimensioning and tolerancing per ASME Y14.5M.
2. This drawing is subject to change without notice.
3. This dimension does not include mold flash, protrusions, or gate burrs. Mold flash, protrusions, or gate burrs shall not exceed 0.15 mm per side.
4. This dimension does not include interlead flash. Interlead flash shall not exceed 0.25 mm per side.
5. Reference JEDEC registration MO-150.

# EXAMPLE BOARD LAYOUT

DB0020A

SSOP - 2 mm max height

SMALL OUTLINE PACKAGE



LAND PATTERN EXAMPLE  
EXPOSED METAL SHOWN  
SCALE: 10X

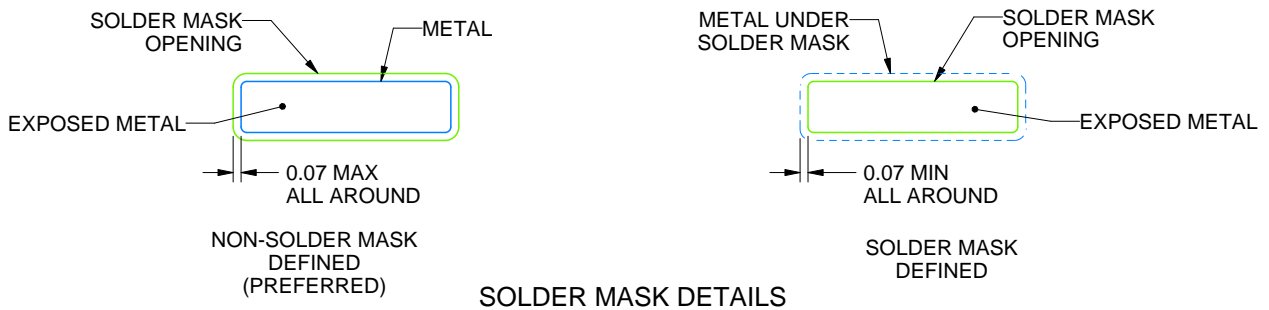

4214851/B 08/2019

NOTES: (continued)

- 6. Publication IPC-7351 may have alternate designs.
- 7. Solder mask tolerances between and around signal pads can vary based on board fabrication site.

# EXAMPLE STENCIL DESIGN

DB0020A

SSOP - 2 mm max height

SMALL OUTLINE PACKAGE

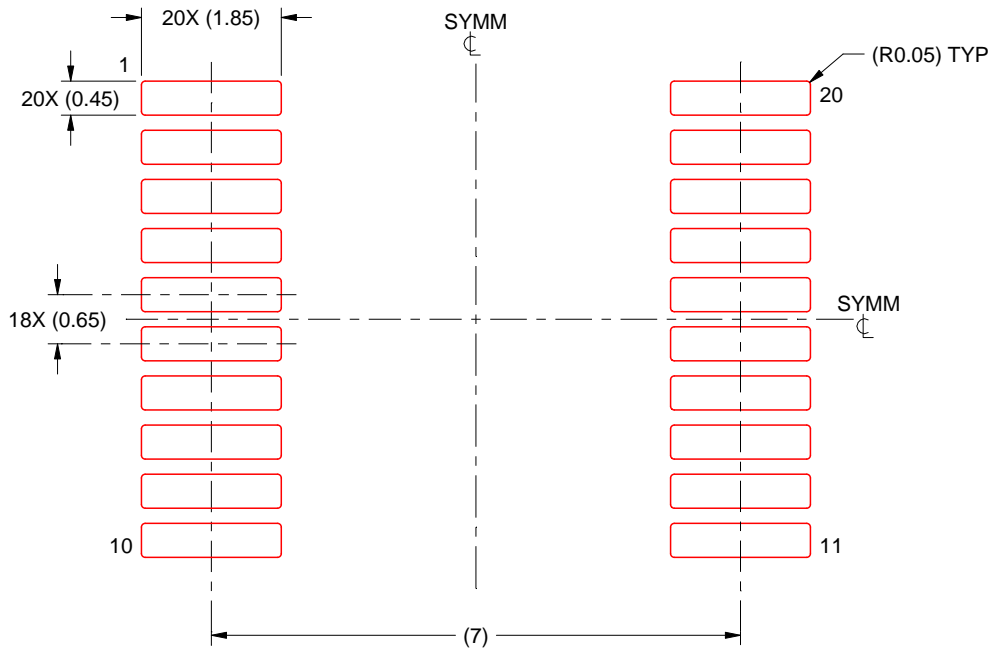

SOLDER PASTE EXAMPLE  
BASED ON 0.125 mm THICK STENCIL  
SCALE: 10X

4214851/B 08/2019

NOTES: (continued)

8. Laser cutting apertures with trapezoidal walls and rounded corners may offer better paste release. IPC-7525 may have alternate design recommendations.
9. Board assembly site may have different recommendations for stencil design.

## IMPORTANT NOTICE AND DISCLAIMER

TI PROVIDES TECHNICAL AND RELIABILITY DATA (INCLUDING DATASHEETS), DESIGN RESOURCES (INCLUDING REFERENCE DESIGNS), APPLICATION OR OTHER DESIGN ADVICE, WEB TOOLS, SAFETY INFORMATION, AND OTHER RESOURCES "AS IS" AND WITH ALL FAULTS, AND DISCLAIMS ALL WARRANTIES, EXPRESS AND IMPLIED, INCLUDING WITHOUT LIMITATION ANY IMPLIED WARRANTIES OF MERCHANTABILITY, FITNESS FOR A PARTICULAR PURPOSE OR NON-INFRINGEMENT OF THIRD PARTY INTELLECTUAL PROPERTY RIGHTS.

These resources are intended for skilled developers designing with TI products. You are solely responsible for (1) selecting the appropriate TI products for your application, (2) designing, validating and testing your application, and (3) ensuring your application meets applicable standards, and any other safety, security, or other requirements. These resources are subject to change without notice. TI grants you permission to use these resources only for development of an application that uses the TI products described in the resource. Other reproduction and display of these resources is prohibited. No license is granted to any other TI intellectual property right or to any third party intellectual property right. TI disclaims responsibility for, and you will fully indemnify TI and its representatives against, any claims, damages, costs, losses, and liabilities arising out of your use of these resources.

TI's products are provided subject to TI's Terms of Sale (<https://www.ti.com/legal/termsofsale.html>) or other applicable terms available either on [ti.com](https://www.ti.com) or provided in conjunction with such TI products. TI's provision of these resources does not expand or otherwise alter TI's applicable warranties or warranty disclaimers for TI products.

Mailing Address: Texas Instruments, Post Office Box 655303, Dallas, Texas 75265  
Copyright © 2021, Texas Instruments Incorporated