

# HIGH EFFICIENCY CHARGE PUMP FOR 7 WLEDs WITH I<sup>2</sup>C INTERFACE

## FEATURES

- 3.0 V to 6.0 V Input Voltage Range
- ×1 and ×1.5 Charge Pump
- Fully Programmable Current with I<sup>2</sup>C
  - 64 Dimming Steps with 25mA Maximum (Sub and Main Display Banks)
  - 4 Dimming Steps with 80mA Maximum (DM5 for Auxiliary Application)
- 2% Current Matching for Sub LEDs at Light Load Condition (Each 100µA)
- 750 kHz Charge Pump Frequency
- Continuous 230mA Maximum Output Current
- Auto Switching Between ×1 and ×1.5 Mode for Maximum Efficiency
- Built-in Soft Start and Current Limit
- Open Lamp Detection
- 16-Pin 3mm x 3mm QFN
- TPS60250 (I<sup>2</sup>C Slave Address: 1110111)
- TPS60252 (I<sup>2</sup>C Slave Address: 1110110)

## APPLICATIONS

- Cellular Phones
- PDA, PMP, GPS (Up To 4 Inch LCD Display)
- Multidisplay Handheld Devices

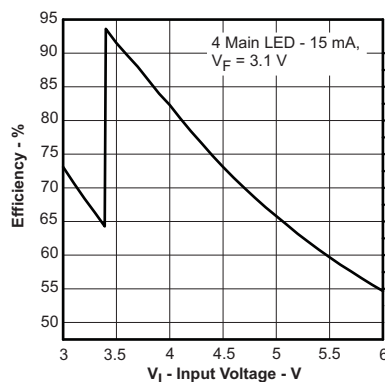

Figure 1. Efficiency vs Input Voltage

## DESCRIPTION

The TPS60250/2 are high efficiency, constant frequency charge pump DC/DC converters that use dual mode 1× and 1.5× conversions to maximize efficiency over the input voltage range. The devices drive up to five white LEDs for the main display and up to two white LEDs for the sub display with regulated constant current for uniform intensity. By utilizing adaptive 1×/1.5× charge pump modes and very low-dropout current regulators, the TPS60250/2 achieve high efficiency over the full 1-cell lithium-battery input voltage range.

Four enable inputs, ENmain, ENsub1, ENsub2, and ENaux, available through the I<sup>2</sup>C, are used for simple on/off controls for the independent main, sub1, sub2, and DM5 displays, respectively. To lower the operating current when using one sub display LED, the devices provide completely separate operation for the sub display LEDs.

The TPS60250/2 are available in a 16-pin 3mm x 3mm thin QFN.

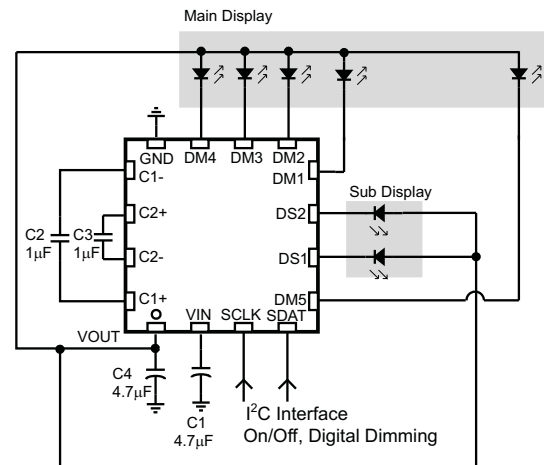

Figure 2. Typical Application for Sub and Main

## ORDERING INFORMATION<sup>(1)</sup>

PART NUMBER	PACKAGE	T <sub>A</sub>
TPS60250RTE	16-Pin 3 mm × 3 mm QFN (RTE)	–40°C to +85°C
TPS60252RTE		

(1) For the most current package and ordering information, see the Package Option Addendum at the end of this document, or see the TI web site at www.ti.com.



Please be aware that an important notice concerning availability, standard warranty, and use in critical applications of Texas Instruments semiconductor products and disclaimers thereto appears at the end of this data sheet.



These devices have limited built-in ESD protection. The leads should be shorted together or the device placed in conductive foam during storage or handling to prevent electrostatic damage to the MOS gates.

## ABSOLUTE MAXIMUM RATINGS

over operating free-air temperature range (unless otherwise noted)<sup>(1)</sup>

		VALUE	UNIT
V <sub>I</sub>	Input voltage range (all pins)	–0.3 to 7	V
	MAX Output current limit	650	mA
	HBM ESD Rating <sup>(2)</sup>	2	kV
	CDM ESD Rating <sup>(3)</sup>	500	V
	MM ESD Rating <sup>(4)</sup>	200	V
T <sub>A</sub>	Operating temperature range	–40 to 85	°C
T <sub>J</sub>	Maximum operating junction temperature	150	°C
T <sub>ST</sub>	Storage temperature	–55 to 150	°C

- (1) Stresses beyond those listed under *absolute maximum ratings* may cause permanent damage to the device. These are stress ratings only and functional operation of the device at these or any other conditions beyond those indicated under *recommended operating conditions* is not implied. Exposure to absolute-maximum-rated conditions for extended periods may affect device reliability.
- (2) The Human body model (HBM) is a 100 pF capacitor discharged through a 1.5kΩ resistor into each pin. The testing is done according JEDECs EIA/JESD22-A114.
- (3) Charged Device Model
- (4) Machine Model (MM) is a 200pF capacitor discharged through a 500 nH inductor with no series resistor into each pin. The testing is done according JEDECs EIA/JESD22-A115.

## DISSIPATION RATINGS

PACKAGE	THERMAL RESISTANCE, R <sub>θJC</sub>	THERMAL RESISTANCE, R <sub>θJA</sub>	T <sub>A</sub> ≤ 25°C POWER RATING	DERATING FACTOR ABOVE T <sub>A</sub> = 25°C	T <sub>A</sub> = 85°C POWER RATING
QFN 3×3 RTE	74.6°C/W	48.7°C/W	2.05 W	1.13 W	0.821 W

## RECOMMENDED OPERATING CONDITIONS

		MIN	NOM	MAX	UNIT
V <sub>I</sub>	Input voltage range	3.0		6.0	V
I <sub>O(max)</sub>	Maximum output current		230		mA
C <sub>I</sub>	Input capacitor		4.7		μF
C <sub>O</sub>	Output capacitor		4.7		μF
C <sub>1</sub> , C <sub>2</sub>	Flying capacitor		1.0		μF
T <sub>A</sub>	Operating ambient temperature	–40		85	°C
T <sub>J</sub>	Operating junction temperature	–40		125	°C

## ELECTRICAL CHARACTERISTICS

V<sub>I</sub> = 3.5 V, T<sub>A</sub> = –40°C to 85°C, typical values are at T<sub>A</sub> = 25°C (unless otherwise noted)

PARAMETER	TEST CONDITIONS	MIN	TYP	MAX	UNIT	
<b>SUPPLY VOLTAGE</b>						
V <sub>I</sub>	Input voltage range	3.0		6.0	V	
I <sub>Q</sub>	Operating quiescent current	750 kHz Switching in 1.5× mode (I <sub>MAIN_LED</sub> = 15 mA × 4, I <sub>O</sub> = 60 mA)		6.7	mA	
		No switching in ×1 mode (I <sub>O</sub> = 100 μA)		68	μA	
I <sub>SD</sub>	Shutdown current	Enable Control Register has 0x00		1.3	μA	
V <sub>UVLO1</sub>	UVLO Threshold voltage1 <sup>(1)</sup>	V <sub>I</sub> falling	2.2	2.4	2.6	V
V <sub>UVLO2</sub>	UVLO Threshold voltage2 <sup>(2)</sup>	V <sub>I</sub> falling	1.2	1.3	1.5	V

- (1) Shut down charge pump and power stage and keep I<sup>2</sup>C content
- (2) Shut down completely and come up with all 0's after device restart

**ELECTRICAL CHARACTERISTICS (continued)**
 $V_I = 3.5\text{ V}$ ,  $T_A = -40^\circ\text{C}$  to  $85^\circ\text{C}$ , typical values are at  $T_A = 25^\circ\text{C}$  (unless otherwise noted)

PARAMETER		TEST CONDITIONS	MIN	TYP	MAX	UNIT
$V_{\text{hys}}$	Under-voltage lockout hysteresis	UVLO1		210		mV
$T_S$	Soft start time <sup>(3)</sup>	$V_I = 3\text{ V}$ , $C_O = 1\ \mu\text{F}$ , $I_{\text{MAIN\_LED}} = 15\text{ mA} \times 4$		0.5		ms
<b>CHARGE PUMP</b>						
$V_{\text{out}}$	Overvoltage limit			6.5		V
$F_s$	Switching frequency			750		kHz
$R_O$	Open loop output impedance	$\times 1$ Mode, $(V_I - V_O)/I_O$			1.2	$\Omega$
		$\times 1.5$ Mode, $(V_I \times 1.5 - V_O)/I_O$ $V_I = 3.0\text{V}$ ( $I_O = 120\text{ mA}$ )		3.5	5.0	
<b>CURRENT SINK</b>						
$K_{\text{m\_sub}}$	Current matching of sub LEDs at light load condition <sup>(4)</sup>	$I_{\text{SUB\_LED}} = 100\ \mu\text{A} \times 2$ , $V_{\text{DXX}} = 0.4\text{ V}$		0	$\pm 2\%$	
$K_{\text{m\_main}}$	LED to LED Current matching <sup>(5)</sup>	$I_{\text{MAIN\_LED}} = 15\text{ mA} \times 4$ , $3.0\text{ V} \leq V_I \leq 4.2\text{ V}$		$\pm 0.1\%$	$\pm 5\%$	
$K_a$	Current accuracy	$I_{\text{LED}} = 15\text{ mA}$			$\pm 7\%$	
$I_{\text{D\_MS}}$	Maximum LED current of DM1-4 and DS1-2	Main and Sub Display Current Register = $0 \times 01 \& 2(111111)$ , $V_{\text{DXX}} = 0.2\text{ V}$		25.5		mA
$I_{\text{D\_DM5}}$	Maximum LED current of DM5	Aux Display Current Register = $0 \times 03$ (XXXX11)		80		mA
$V_{\text{DropOut}}$	LED Drop out voltage	See <sup>(6)</sup>		80	120	mV
$V_{\text{TH\_GU}}$	$1 \times$ Mode to $1.5 \times$ mode transition threshold voltage <sup>(7)</sup>	$V_{\text{DXX}}$ Falling, $15\text{ mA} \times 4$ measured on the lowest $V_{\text{DXX}}$	85	100	120	mV
$V_{\text{TH\_GD}}$	Input voltage hysteresis for $1.5 \times$ to $1 \times$ mode transition	Measured as $V_I - (V_O - V_{\text{DXX\_MIN}})$ , $I_{\text{MAIN\_LED}} = 15\text{ mA} \times 4$		550		mV
<b>SERIAL INTERFACE TIMING REQUIREMENTS</b>						
$f_{\text{max}}$	Clock frequency				400	kHz
$t_{\text{WH(HIGH)}}$	Pulse duration, clock high time			600		ns
$t_{\text{WL(LOW)}}$	Pulse duration, clock low time			1300		ns
$t_r$	DATA and CLK rise time				300	ns
$t_f$	DATA and CLK fall time				300	ns
$t_{\text{H(STA)}}$	High time (repeated) START condition(after this period the first clock pulse is generated)			600		ns
$t_{\text{SU(STA)}}$	Setup time for repeated START condition			600		ns
$t_{\text{H(DATA)}}$	Data input hold time			0		ns
$t_{\text{SU(DATA)}}$	Data input setup time			100		ns
$t_{\text{SU(STO)}}$	STOP condition setup time			600		ns
$t_{\text{(BUF)}}$	Bus free time			1300		ns
<b>I<sup>2</sup>C COMPATIBLE INTERFACE VOLTAGE SPECIFICATION (SCLK, SDAT, VIO)</b>						
$V_{\text{IL}}$	Low-level input voltage	$3.0\text{ V} \leq V_I \leq 6.0\text{ V}$	0		0.5	V
$V_{\text{IH}}$	High-level input voltage	$3.0\text{ V} \leq V_I \leq 6.0\text{ V}$	1.1			V
$V_{\text{OL}}$	Low-level output voltage	$I_{\text{LOAD}} = 2\text{ mA}$			0.4	V

(3) Measurement Condition: From enabling the LED driver to 90% output voltage after  $V_I$  is already up.

(4) LED current matching is defined as:  $(I_{\text{SUB\_LED\_WORST}} - I_{\text{AVG\_SUB}}) / I_{\text{AVG\_SUB}}$

(5) LED to LED Current Matching is defined as:  $(I_{\text{MAIN\_LED\_WORST}} - I_{\text{AVG\_MAIN}}) / I_{\text{AVG\_MAIN}}$

(6) Dropout Voltage is defined as  $V_{\text{DXX}}$  (WLED Cathode) to GND voltage at which current into the LED drops 10% from the LED current at  $V_{\text{DXX}} = 0.2\text{ V}$ , WLED current =  $15\text{ mA} \times 4$ .

(7) As  $V_I$  drops,  $V_{\text{DXX}}$  eventually falls below the switchover threshold of 100mV, and TPS60250/2 switches to  $1.5 \times$  mode. See the *Operating Principle* section for details about the mode transition thresholds.

## PIN ASSIGNMENTS

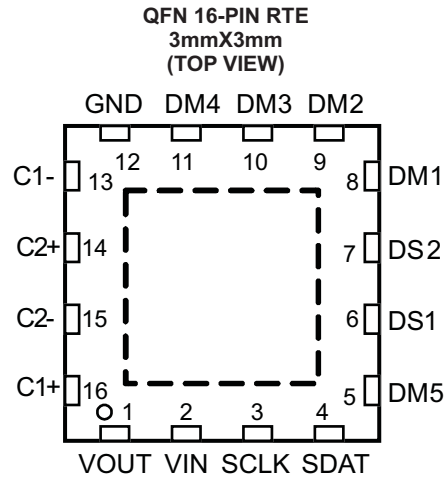

## TERMINAL FUNCTIONS

TERMINAL		I/O	DESCRIPTION
NAME	NO.		
VOUT	1	O	Connect the anodes of the sub, main, and aux display white LEDs to this pin.
VIN	2	I	Supply voltage input. Connect to a 3 V to 6 V input supply source.
SCLK	3	I	I <sup>2</sup> C Interface
SDAT	4	I/O	I <sup>2</sup> C Interface
DM5	5	I	Current sink inputs. Connect the cathode of the aux display or the 5th main display white LED to this pin.
DS1	6	I	Current sink inputs. Connect the cathode of one of the sub display white LEDs to these pins.
DS2	7	I	
DM1	8	I	Current sink input. Connect the cathode of one of the main display white LEDs to these pins.
DM2	9	I	
DM3	10	I	
DM4	11	I	
GND	12	–	Ground
C1–	13	–	Connect to the flying capacitor C1
C2+	14	–	Connect to the flying capacitor C2
C2–	15	–	Connect to the flying capacitor C2
C1+	16	–	Connect to the flying capacitor C1

FUNCTIONAL BLOCK DIAGRAM

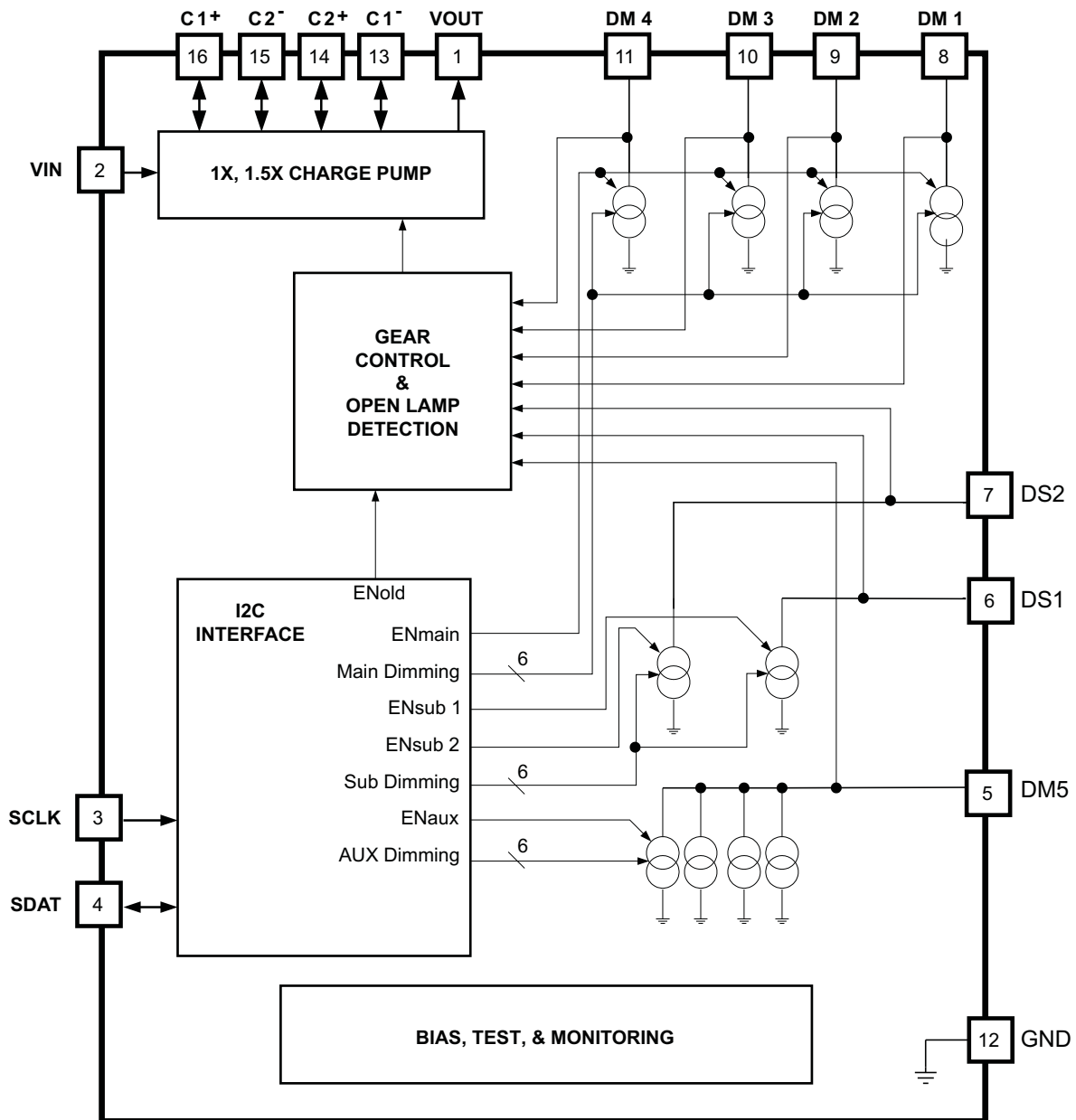

TYPICAL CHARACTERISTICS

TABLE OF GRAPHS

DESCRIPTION		REF
Efficiency	Efficiency vs Input Voltage, 4 Main LED - 15 mA, 25 mA	Figure 3
	Efficiency vs Input Voltage, 2 Sub LED with Light Load Condition, ×1 Mode Operation	Figure 4
Output Impedance of ×1 and ×1.5 Mode	Switch Resistance vs Free-Air Temperature, ×1 Mode, I <sub>LED</sub> = 230 mA	Figure 5
	Switch Resistance vs Free-Air Temperature, ×1 Mode, I <sub>LED</sub> = 100 mA	Figure 6
	Switch Resistance vs Free-Air Temperature, ×1.5 Mode Charge Pump Open-Loop, I <sub>LED</sub> = 230 mA	Figure 7
	Switch Resistance vs Free-Air Temperature, ×1.5 Mode Charge Pump Open-Loop, I <sub>LED</sub> = 100 mA	Figure 8
Shutdown Current	Shutdown Current vs Input Voltage	Figure 9

TYPICAL CHARACTERISTICS (continued)

DESCRIPTION		REF
Input Current	Input Current vs Supply Voltage, 4 Main LED	Figure 10
DM5 with Maximum 80 mA	DM5 Current vs Input Voltage, Programmed with 80 mA	Figure 11
Current Accuracy	WLED Current vs Input Voltage, 4 Main LED with 15 mA	Figure 12

EFFICIENCY  
VS  
INPUT VOLTAGE  
(4 Main LED - 15mA, 25mA)

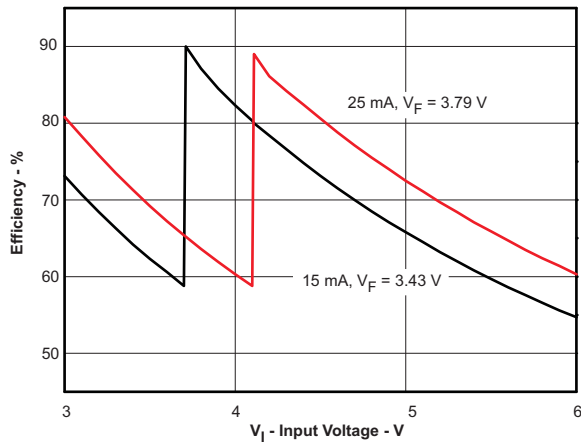

Figure 3.

EFFICIENCY  
VS  
INPUT VOLTAGE  
(2 Sub LED with Light Load Condition,  
×1 Mode Operation)

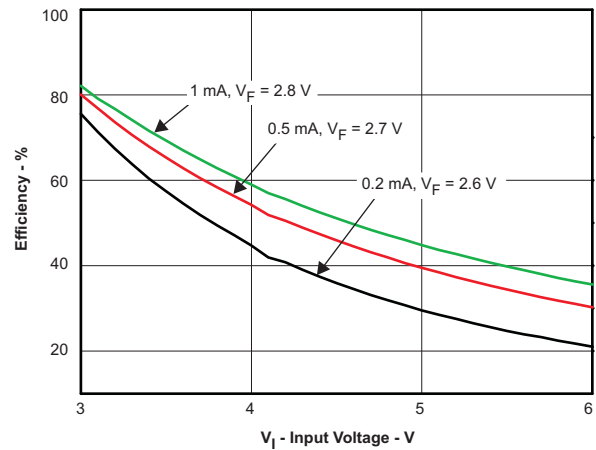

Figure 4.

SWITCH RESISTANCE  
VS  
FREE-AIR TEMPERATURE  
(×1 Mode)

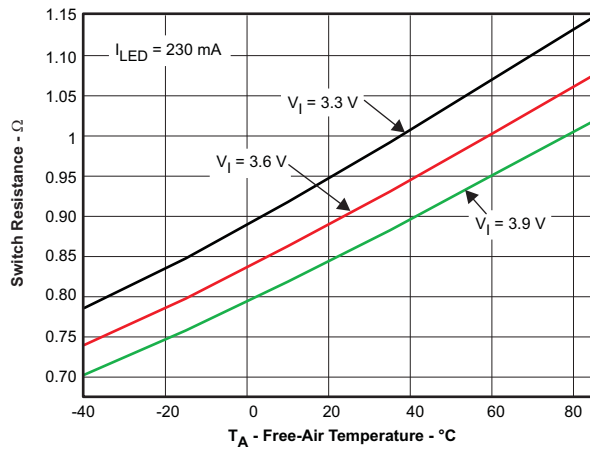

Figure 5.

SWITCH RESISTANCE  
VS  
FREE-AIR TEMPERATURE  
(×1 Mode)

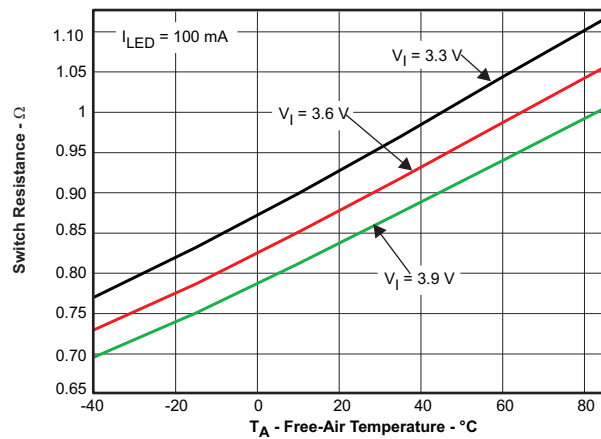

Figure 6.

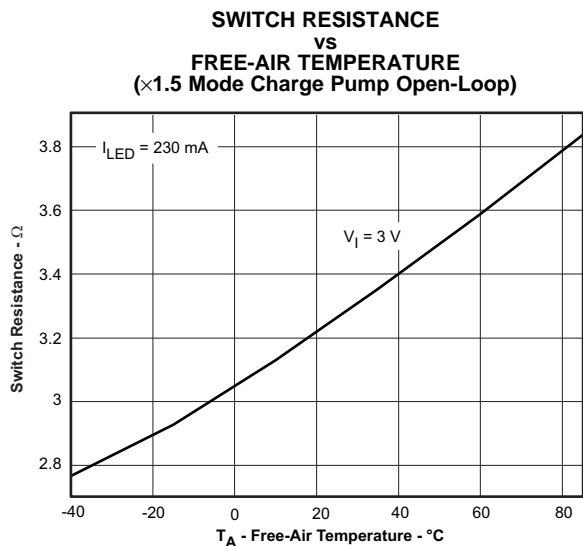

Figure 7.

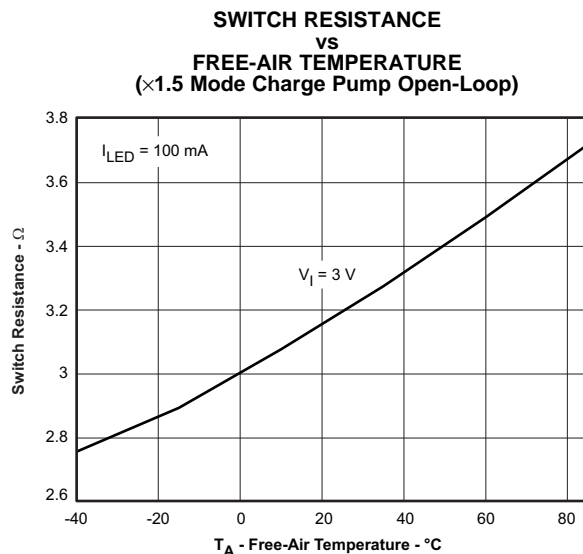

Figure 8.

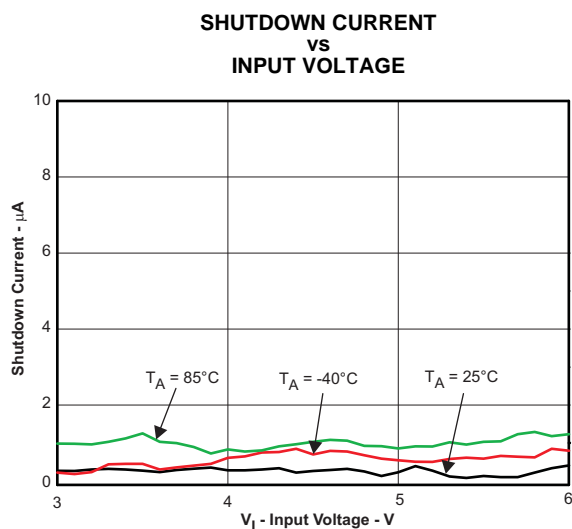

Figure 9.

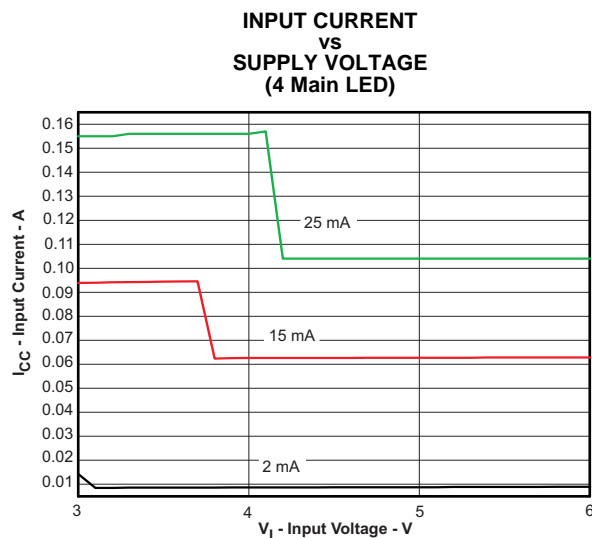

Figure 10.

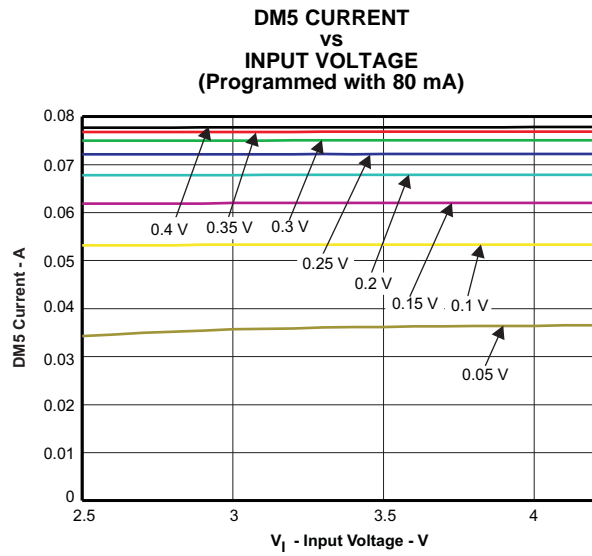

Figure 11.

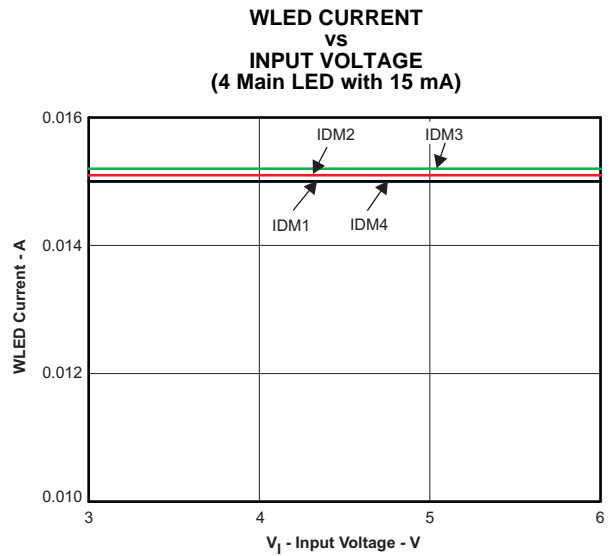

Figure 12.

## APPLICATION INFORMATION

### APPLICATION OVERVIEW

Most of the current handsets fall into one of three categories. First is the clamshell design, with a main display on the inside, a secondary display on the outside and a keypad backlight. Second is the bar design, with a main display and a keypad backlight. Third is the slide type (slide-up and slide-down) design, with a main display and two keypad banks (inside and outside). The TPS60250/2 are well suited for use in these three major phone designs because the devices have 7 individually regulated white LED current paths that drive up to five white LEDs in the main display and up to two white LEDs in sub display with regulated constant current for uniform intensity. The main and sub display LED channels drive up to 25 mA and the auxiliary LED output (DM5) that drives up to 80 mA can be assigned to keypad backlight, torch light, or low cost/weak camera flash application using the I<sup>2</sup>C interface.

The TPS60250/2 circuits use only 4 external components: the input/output capacitors and 2 charge pump flying capacitors. The few external components combined with the small 3mm × 3mm QFN package provide for a small total solution size. By combining independent control of three separate banks of backlight LEDs with low cost and weak flash capability, the TPS60250/2 help designers minimize power consumption especially in the case of a light load condition while reducing component count and package size.

### OPERATING PRINCIPLE

Charge pumps are becoming increasingly attractive in battery-operated applications where board space and maximum height of the converter are critical constraints. The major advantage of a charge pump is the use of only capacitors as storage elements. The TPS60250/2 charge pumps provide regulated LED current from a 3 V to 6 V input source. The devices operate in two modes. The 1× mode, where the input is connected to the output through a pass element, and a high efficiency 1.5× charge pump mode. The IC maximizes power efficiency by operating in 1× and 1.5× modes as input voltage and LED current conditions require. The mode of operation is automatically selected by comparing the forward voltage of the WLED plus the voltage of current sink for each LED with the input voltage. The IC starts up in 1× mode, and automatically transitions to 1.5× if the voltage at any current sink input (DM\_ or DS\_) falls below the 100 mV transition voltage. The IC returns to 1× mode as the input rises. [Figure 13](#) provides a visual explanation of the 1× to 1.5× transition.

In 1.5× mode, the internal oscillator determines the charge/discharge cycles for the flying capacitors. During a charge cycle, the flying capacitors are connected in series and charged up to the input voltage. After the on-time of the internal oscillator expires, the flying capacitors are reconfigured to be in parallel and then connected in series to the input voltage. This provides an output of 1.5× the input voltage. After the off-time of the internal oscillator expires, another charge cycle initiates and the process repeats.

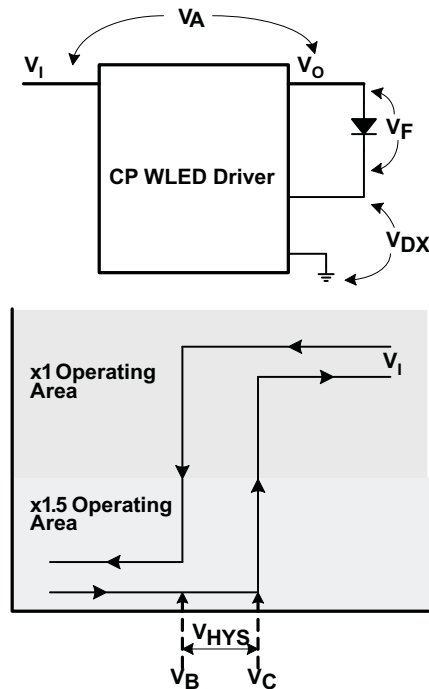

Figure 13. Input Voltage Hysteresis Between  $\times 1$  and  $\times 1.5$  Mode

As shown in Figure 13, there is input hysteresis voltage between  $1\times$  and  $1.5\times$  mode to ensure stable operation during mode transition. For the 1 cell Li-Ion battery input voltage range, the TPS6025/2 operate in  $1\times$  mode when a fully charged battery is installed. Once the battery voltage drops below the  $V_B$  level, which is the mode transition voltage from  $1\times$  to  $1.5\times$ , the WLED driver operates in  $1.5\times$  mode. Once in  $1.5\times$  mode, the battery voltage must rise to the  $V_C$  level in order to transition from  $1.5\times$  to  $1\times$ . This hysteresis ensures stable operation when there is some input voltage fluctuation at the  $1\times/1.5\times$  mode transition.

The transition voltage,  $V_B$ , depends on  $V_{DX}$  (the mode transition threshold voltage),  $V_F$  (WLED forward voltage drop) and  $V_A$  (the drop out voltage of the charge pump stage) and is calculated as follows:

$$V_B = V_A + V_F + V_{DX}$$

$$V_A = R_{OUT1X} \times I_{LEDTOTAL}$$

Where  $R_{OUT1X}$  is the  $1\times$  mode output impedance of the IC. See the Electrical Characteristics table for output impedance specifications.

The TPS60250/2 switch up to  $1.5\times$  mode when the input voltage is below  $V_B$  and remain in  $1.5\times$  mode as long as the input is lower than  $V_C$ .  $1.5\times$  Mode is exited when the input voltage rises above  $V_C$ .  $V_C$  is calculated as:

$$V_C = V_F + 550 \text{ mV}$$

The input voltage mode transition hysteresis voltage ( $V_{HYS}$ ) between  $1\times$  and  $1.5\times$  is calculated using the following equation.

$$V_{HYS} = V_C - V_B = 550 \text{ mV} - V_{DX} - V_A, \text{ where } V_{DX} = 100\text{mV}$$

Note that  $V_A$  is the key factor in determining  $V_{HYS}$  and is dependant on the  $1\times$  mode charge pump output impedance and WLED current.

## LED CURRENT SINKS (DM\_, DS\_)

The TPS60250/2 have constant current sinks which drive seven individual LED current paths. Each current sink regulates the LED current to a constant value determined by the I<sup>2</sup>C interface. The internal register addressing allows the LED main channels DM1~DM5 to be controlled independently from the LED sub channels DS1~DS2. All LED channels sink up to 25 mA of current except DM5 which has an 80 mA maximum current when configured as an auxiliary output. Using the I<sup>2</sup>C interface, the user may assign DM5 to the main display bank with up to 25 mA current or as an auxiliary output for torch or keypad light or low/weak camera flash with 80 mA current. DM5 has 64 dimming steps; the same as the main and sub display banks when assigned to the main display. However, it has its own current programming register and enable control. When assigned as an auxiliary, DM5 has 4 dimming steps (full scale, 70%, 40%, 20%).

These optimized current sinks minimize the voltage headroom required to drive each LED and maximize power efficiency by increasing the amount of time the controller stays in 1× mode before transitioning to 1.5× mode.

## OPEN LAMP DETECTION

In system production it is often necessary to leave LED current paths open depending on the phone model. For example, one phone may use 2 LEDs to backlight the main display while another uses 4 LEDs. Rather than use two different ICs for these different phone applications, the TPS60250/2 may be used in both applications with no additional efficiency loss in the 2 LED applications. In traditional LED driver applications when an LED current path is open, the current sink voltage falls to ground and the current regulation circuitry drives the output to maximum voltage in an attempt to regulate the current for the missing LED path. This severely reduces system efficiency. The TPS60250/2 use 7 internal comparators to detect open lamp condition, when one or more open LED conditions occur, TPS60250/2 prevent activation of 1.5X mode transition due to missing LEDs. Open lamp detection is enabled/disabled using the I<sup>2</sup>C interface.

## CAPACITOR SELECTION

The TPS60250/2 are optimized to work with ceramic capacitors with a dielectric of X5R or better. The two flying capacitors must be the same value for proper operation. The 750 kHz switching frequency requires that the flying capacitor be less than 4.7 μF. Use of 1 μF ceramic capacitors for both charge pump flying capacitors is recommended.

For good input voltage filtering, low ESR ceramic capacitors are recommended. A 1 μF ceramic input capacitor is sufficient for most applications. For better input voltage filtering this value can be increased to 4.7 μF.

The output capacitor controls the amount of ripple on the output. Since small ripple is undetectable by the human eye, a 4.7 μF output capacitor works well. If better output filtering and lower ripple is desired, a larger output capacitor may be used.

## SETTING THE LED CURRENT

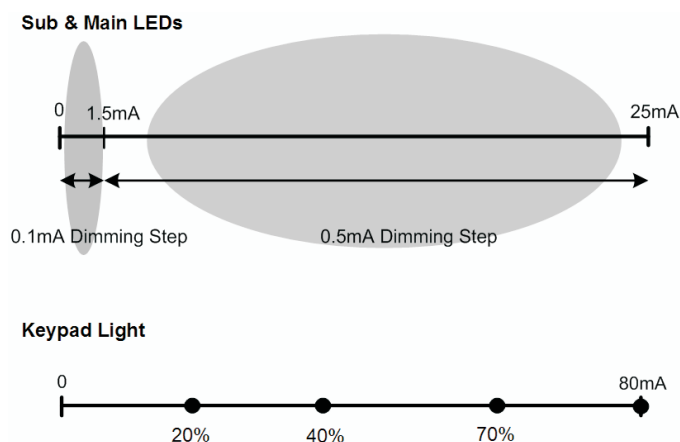

Figure 14. Dimming Steps for Sub, Main, and Keypad Backlight

Figure 14 shows the dimming steps for sub, main, and auxiliary display banks in a 25 mA maximum current

applications. In order to satisfy today's requirements on LED current, the TPS60250/2 cover the low LED current area from 100  $\mu$ A to 1.5 mA with 100  $\mu$ A dimming steps (total 16 steps for a 25 mA maximum current) for the new LCD panels which have improved transparency rates. For LED currents in the range from 2 mA to 25 mA, the devices use 48 dimming steps with 0.5 mA steps. Also, DM5 has 4 dimming steps once the current path is assigned for auxiliary applications with a 80 mA maximum current.

## SERIAL INTERFACE

The serial interface is compatible with the standard and fast mode I<sup>2</sup>C specifications, allowing transfers at up to 400 kHz. The interface adds flexibility to the WLED driver solution, enabling most functions to be programmed to new values depending on the instantaneous application requirements. Register contents remain intact as long as V<sub>CC</sub> remains above UVLO2 (typical 1.3 V).

For normal data transfer, DATA is allowed to change only when CLK is low. Changes when CLK is high are reserved for indicating the start and stop conditions. During data transfer, the data line must remain stable whenever the clock line is high. There is one clock pulse per bit of data. Each data transfer is initiated with a start condition and terminated with a stop condition. When addressed, the TPS60250/2 devices generate an acknowledge bit after the reception of each byte. The master device (microprocessor) must generate an extra clock pulse that is associated with the acknowledge bit. The TPS60250/2 devices must pull down the DATA line during the acknowledge clock pulse so that the DATA line is a stable low during the high period of the acknowledge clock pulse. Setup and hold times must be taken into account. During read operations, a master must signal the end of data to the slave by not generating an acknowledge bit on the last byte that was clocked out of the slave. In this case, the slave TPS60250/2 devices must leave the data line high to enable the master to generate the stop condition.

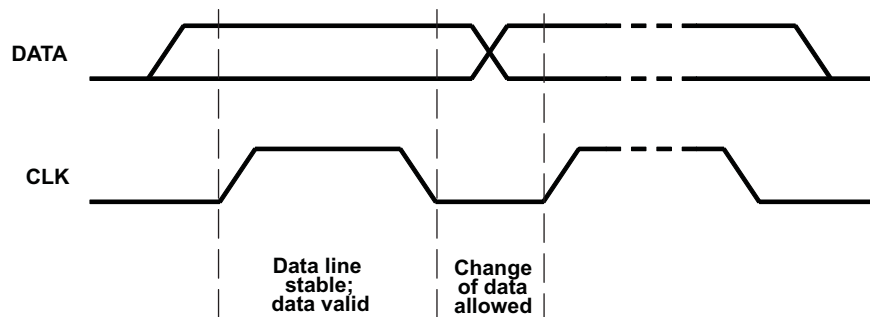

Figure 15. Bit Transfer on the Serial Interface

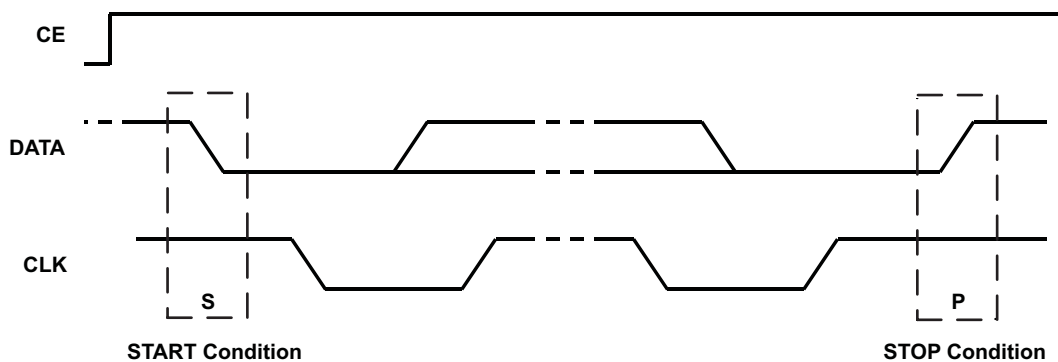

Figure 16. START and STOP Conditions

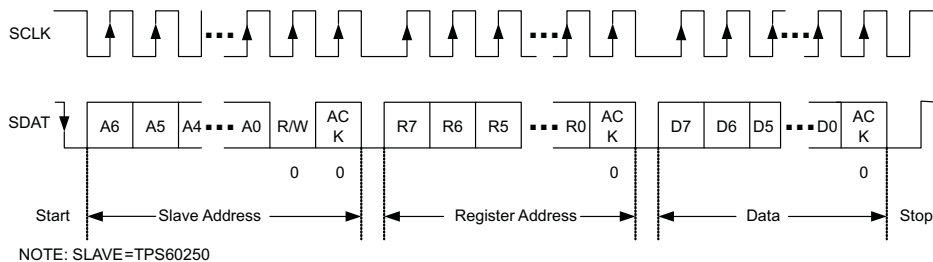

Figure 17. Serial I/F READ From TPS60250/2: Protocol A

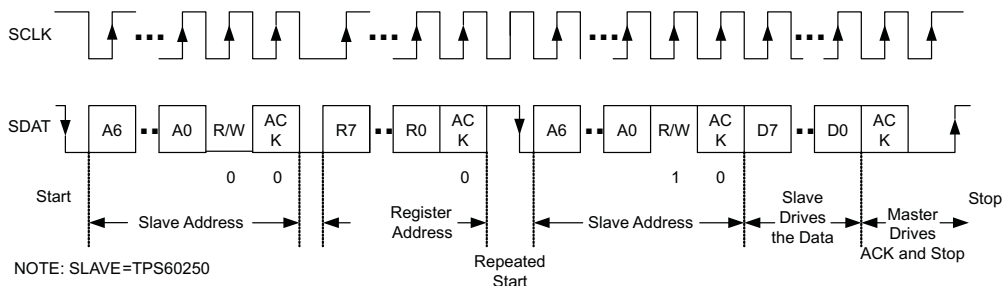

Figure 18. Serial I/F READ From TPS60250/2: Protocol B

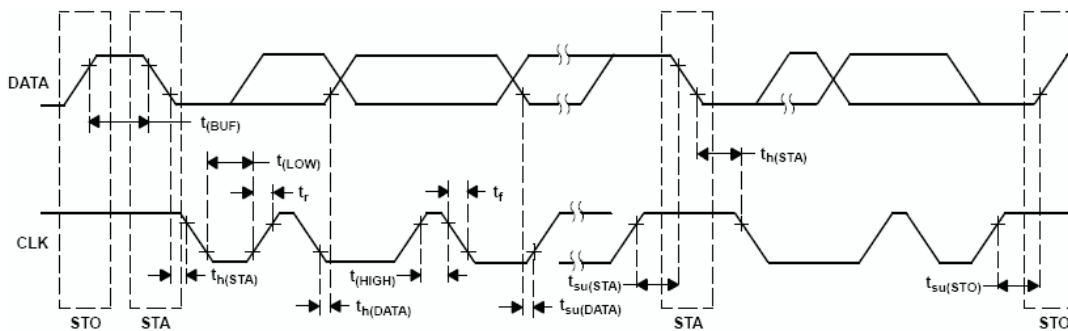

Figure 19. Serial I/F Timing Diagram

The I<sup>2</sup>C interface uses a combined protocol in which the START condition and the Slave Address are both repeated. The TPS60250 provides two I<sup>2</sup>C Slave Addresses using an internal EEPROM in case more than 1 device is used in the system. The TPS60250 primary I<sup>2</sup>C Slave Address is **1110111** and the TPS60252 primary I<sup>2</sup>C Slave Address is **1110110**. For the alternative I<sup>2</sup>C addresses, contact the factory.

**Enable Control Register (Address: 0x00h)**

ENABLE	B7	B6	B5	B4	B3	B2	B1	B0
BIT NAME	X	ENold	ENmain	ENsub2	ENsub1	ENaux	DM5H	DM5L

Bit 6 ENold (Enable Open Lamp Detection)  
1: Open Lamp Detection Enabled  
0: Open Lamp Detection Disabled

Bit 5 ENmain  
1: Enable Main Display LEDs (DM1-DM4)  
0: Disable Main Display LEDs

Bit 4 ENsub2  
1: Enable Sub Display LED 2 (DS2)  
0: Disable Sub Display LED 2

Bit 3 ENsub1  
1: Enable Sub Display LED 1 (DS1)  
0: Disable Sub Display LED 1

Bit 2 ENaux  
1: Enable Aux Display LED (DM5)  
0: Disable Aux Display LED

Bits 1,0 DM5H, DM5L

DM5H (B1)	DM5L (B0)	DM5 Mode and Shutdown Mode
0	0	Shutdown mode. All outputs disabled but keep register values
0	1	Enable the IC and Group DM5 as main display with maximum current of 25 mA
1	0	Enable the IC and set DM5 as Aux output with maximum current of 80 mA. Dimming steps determined by laux0 and laux1 bits.
1	1	Shutdown mode. All outputs disabled but keep register values

**Sub Display Current Control Register (Address: 0x01h)**

SUB DISP CURRENT	B7	B6	B5	B4	B3	B2	B1	B0
BIT NAME	X	X	lsub5	lsub4	lsub3	lsub2	lsub1	lsub0

Bits 5 - 0 lsub5 - lsub0 (total 64 steps)  
6-Bit command (64 steps) to these bits sets the current for DS1 and DS2.  
For LED currents between 0 and 1.5 mA, one step = 0.1 mA increment  
For LED currents between 1.5 and 25.5 mA, one step = 0.5 mA increment

**Main Display Current Control Register (Address: 0x02h)**

MAIN DISP CURRENT	B7	B6	B5	B4	B3	B2	B1	B0
BIT NAME	X	X	lmain5	lmain4	lmain3	lmain2	lmain1	lmain0

Bits 5 - 0 lmain5 - lmain0 (total 64 steps)  
6-Bit command (64 steps) to these bits sets the current for DM1-DM4.  
For LED currents between 0 and 1.5 mA, one step = 0.1mA increment  
For LED currents between 1.5 and 25.5 mA, one step = 0.5 mA increment

**Aux Output Brightness and Operation Mode Control Register (Address: 0x03h)**

AUX DISP CURRENT	B7	B6	B5	B4	B3	B2	B1	B0
BIT NAME	iaux5	iaux4	iaux3	iaux2	iaux1	iaux0	Mode1	Mode0

Bits 7 - 2 (DM5 set to Main Display Mode)

iaux5 - iaux0 (total 64 steps)

6-Bit command (64 steps) to these bits sets the current for DM5.

For LED currents between 0 and 1.5 mA, one step = 0.1mA increment

For LED currents between 1.5 and 25.5 mA, one step = 0.5 mA increment

Bits 7 - 2 (DM5 set to Aux Display Mode)

iaux5 (B7)	iaux4 (B6)	iaux3 (B5)	iaux2 (B4)	iaux1 (B3)	iaux0 (B2)	Aux Dimming Step
X	X	X	X	0	0	20%
X	X	X	X	0	1	40%
X	X	X	X	1	0	70%
X	X	X	X	1	1	100%

Bits 1,0 Mode1, Mode0

Mode1 (B1)	Mode0 (B0)	TPS60250/2 Mode
0	0	Auto-Switchover Mode. The TPS60250/2 select 1×/1.5× mode as described in the <i>Operating Principle</i> section.
0	1	1× Mode. TPS60250/2 remain in 1× mode regardless of the input voltage. LED current may not regulate at lower input voltages when in this mode.
1	0	1.5× Mode. TPS60250/2 remain in 1.5× mode regardless of the input voltage.
1	1	Auto-Switchover Mode. The TPS60250/2 select 1×/1.5× mode as described in the <i>Operating Principle</i> section.

APPLICATION CIRCUITS

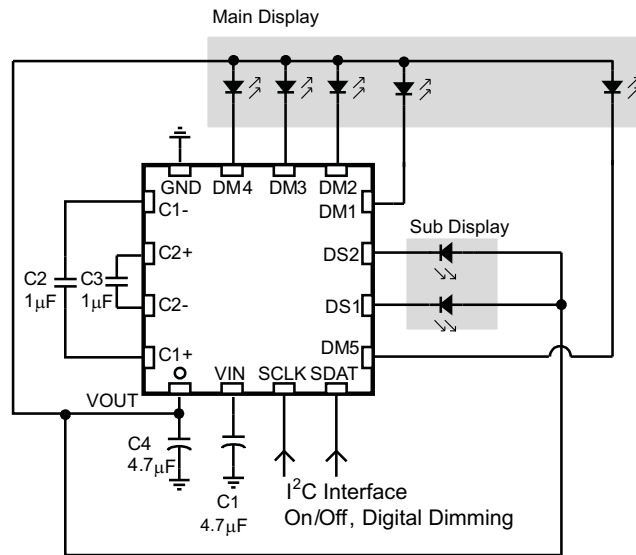

Figure 20. The Typical Application Circuit for Sub and Main Display

As shown in Figure 20, typical application circuit for a clam shell phone has 5 main LEDs and 2 sub LEDs. Recently, the LCD panel makers have developed a new panel that has an improved transparency rate which makes system efficiency with 100 µA LED current a critical load point. To meet system efficiency requirements with the light load conditions for the new LCD operating panels, the TPS60250/2 have a maximum 55 µA operating current with 100 µA output load condition. In this application, the controller always operates in 1× mode due to the WLED's low forward voltage drop (about 2.6 V<sub>F</sub> with a 100 µA WLED current). Thus, the total efficiency at the light load condition is determined using Equation 1:

$$\eta_{\text{Light}} = \frac{I_O \times V_F}{V_{\text{in}} \times (I_O + I_{\text{op}})} \tag{1}$$

Where:

- I<sub>O</sub>: Output Load (WLED) Current
- V<sub>F</sub>: Forward Voltage Drop of WLED
- V<sub>in</sub>: Input Voltage
- I<sub>op</sub>: Operating Current of LED Driver

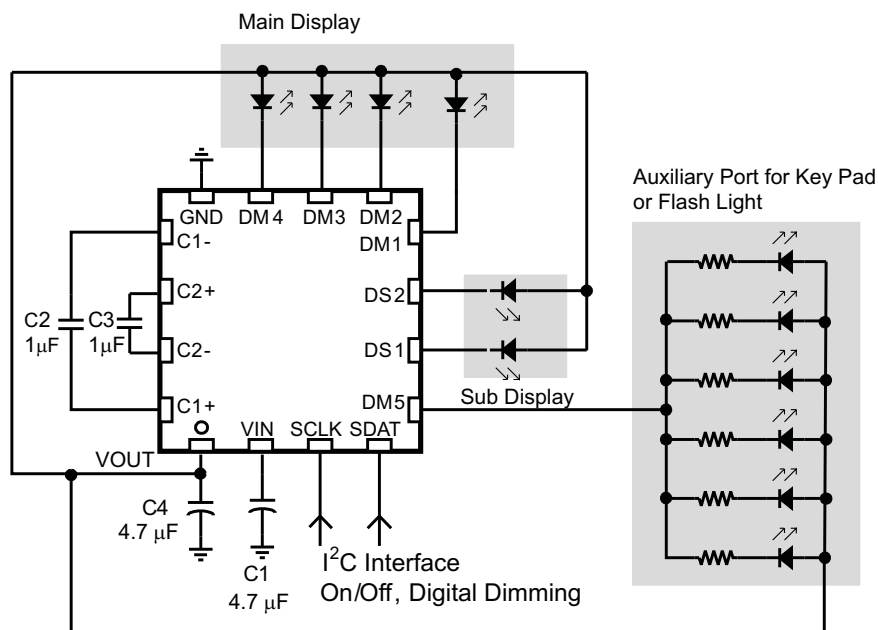

**Figure 21. The Typical Application Circuit for Sub, Main, and Keypad Backlight**

Figure 21 shows the typical application circuit for sub, main, and keypad backlight. In this application, DM5 is assigned as the auxiliary input for the keypad lighting application.

### LAYOUT GUIDELINES

There are several points to consider when laying out a PCB for charge pump based solutions. In general, all capacitors should be as close as possible to the device. This is especially important when placing the flying capacitors (C2, C3 in Figure 20 and Figure 21). In cases where DM5 is assigned for torch/flash applications, with a maximum 80 mA WLED current, this current path must be kept wide to reduce the trace resistance.

## Revision History

Changes from Revision B (November 2007) to Revision C	Page
• Added TPS60252 device information .....	1

**PACKAGING INFORMATION**

Orderable Device	Status (1)	Package Type	Package Drawing	Pins	Package Qty	Eco Plan (2)	Lead finish/ Ball material (6)	MSL Peak Temp (3)	Op Temp (°C)	Device Marking (4/5)	Samples
TPS60250RTER	ACTIVE	WQFN	RTE	16	3000	RoHS & Green	NIPDAU	Level-2-260C-1 YEAR	-40 to 85	BSR	<a href="#">Samples</a>
TPS60250RTET	ACTIVE	WQFN	RTE	16	250	RoHS & Green	NIPDAU	Level-2-260C-1 YEAR	-40 to 85	BSR	<a href="#">Samples</a>
TPS60252RTER	ACTIVE	WQFN	RTE	16	3000	RoHS & Green	NIPDAU	Level-2-260C-1 YEAR	-40 to 85	CFN	<a href="#">Samples</a>
TPS60252RTET	ACTIVE	WQFN	RTE	16	250	RoHS & Green	NIPDAU	Level-2-260C-1 YEAR	-40 to 85	CFN	<a href="#">Samples</a>

(1) The marketing status values are defined as follows:

**ACTIVE:** Product device recommended for new designs.

**LIFEBUY:** TI has announced that the device will be discontinued, and a lifetime-buy period is in effect.

**NRND:** Not recommended for new designs. Device is in production to support existing customers, but TI does not recommend using this part in a new design.

**PREVIEW:** Device has been announced but is not in production. Samples may or may not be available.

**OBSOLETE:** TI has discontinued the production of the device.

(2) **RoHS:** TI defines "RoHS" to mean semiconductor products that are compliant with the current EU RoHS requirements for all 10 RoHS substances, including the requirement that RoHS substance do not exceed 0.1% by weight in homogeneous materials. Where designed to be soldered at high temperatures, "RoHS" products are suitable for use in specified lead-free processes. TI may reference these types of products as "Pb-Free".

**RoHS Exempt:** TI defines "RoHS Exempt" to mean products that contain lead but are compliant with EU RoHS pursuant to a specific EU RoHS exemption.

**Green:** TI defines "Green" to mean the content of Chlorine (Cl) and Bromine (Br) based flame retardants meet JS709B low halogen requirements of <=1000ppm threshold. Antimony trioxide based flame retardants must also meet the <=1000ppm threshold requirement.

(3) MSL, Peak Temp. - The Moisture Sensitivity Level rating according to the JEDEC industry standard classifications, and peak solder temperature.

(4) There may be additional marking, which relates to the logo, the lot trace code information, or the environmental category on the device.

(5) Multiple Device Markings will be inside parentheses. Only one Device Marking contained in parentheses and separated by a "-" will appear on a device. If a line is indented then it is a continuation of the previous line and the two combined represent the entire Device Marking for that device.

(6) Lead finish/Ball material - Orderable Devices may have multiple material finish options. Finish options are separated by a vertical ruled line. Lead finish/Ball material values may wrap to two lines if the finish value exceeds the maximum column width.

**Important Information and Disclaimer:**The information provided on this page represents TI's knowledge and belief as of the date that it is provided. TI bases its knowledge and belief on information provided by third parties, and makes no representation or warranty as to the accuracy of such information. Efforts are underway to better integrate information from third parties. TI has taken and

continues to take reasonable steps to provide representative and accurate information but may not have conducted destructive testing or chemical analysis on incoming materials and chemicals. TI and TI suppliers consider certain information to be proprietary, and thus CAS numbers and other limited information may not be available for release.

In no event shall TI's liability arising out of such information exceed the total purchase price of the TI part(s) at issue in this document sold by TI to Customer on an annual basis.

**TAPE AND REEL INFORMATION**

**QUADRANT ASSIGNMENTS FOR PIN 1 ORIENTATION IN TAPE**

\*All dimensions are nominal

Device	Package Type	Package Drawing	Pins	SPQ	Reel Diameter (mm)	Reel Width W1 (mm)	A0 (mm)	B0 (mm)	K0 (mm)	P1 (mm)	W (mm)	Pin1 Quadrant
TPS60250RTER	WQFN	RTE	16	3000	330.0	12.4	3.3	3.3	1.1	8.0	12.0	Q2
TPS60250RTET	WQFN	RTE	16	250	180.0	12.4	3.3	3.3	1.1	8.0	12.0	Q2
TPS60252RTER	WQFN	RTE	16	3000	330.0	12.4	3.3	3.3	1.1	8.0	12.0	Q2
TPS60252RTET	WQFN	RTE	16	250	180.0	12.4	3.3	3.3	1.1	8.0	12.0	Q2

**TAPE AND REEL BOX DIMENSIONS**

\*All dimensions are nominal

Device	Package Type	Package Drawing	Pins	SPQ	Length (mm)	Width (mm)	Height (mm)
TPS60250RTER	WQFN	RTE	16	3000	853.0	449.0	35.0
TPS60250RTET	WQFN	RTE	16	250	210.0	185.0	35.0
TPS60252RTER	WQFN	RTE	16	3000	853.0	449.0	35.0
TPS60252RTET	WQFN	RTE	16	250	210.0	185.0	35.0

## GENERIC PACKAGE VIEW

**RTE 16**

**WQFN - 0.8 mm max height**

3 x 3, 0.5 mm pitch

PLASTIC QUAD FLATPACK - NO LEAD

This image is a representation of the package family, actual package may vary.  
Refer to the product data sheet for package details.

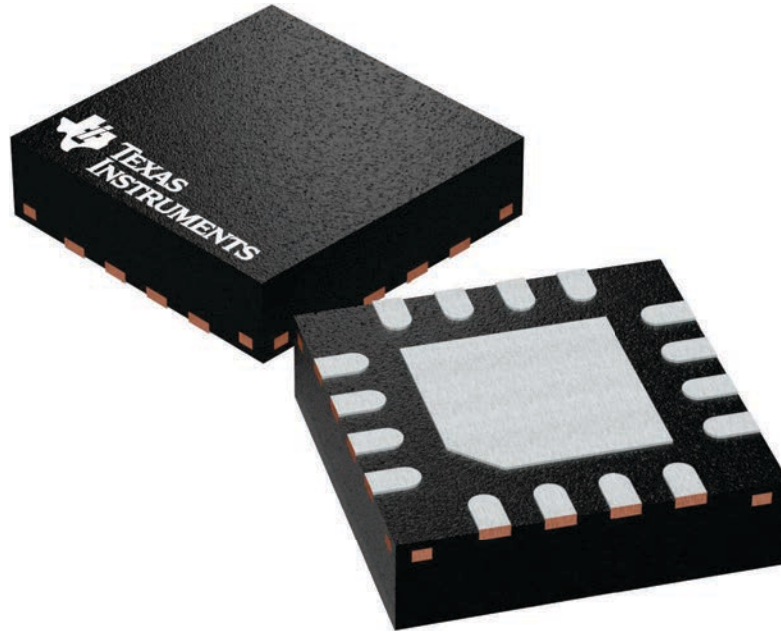

4225944/A

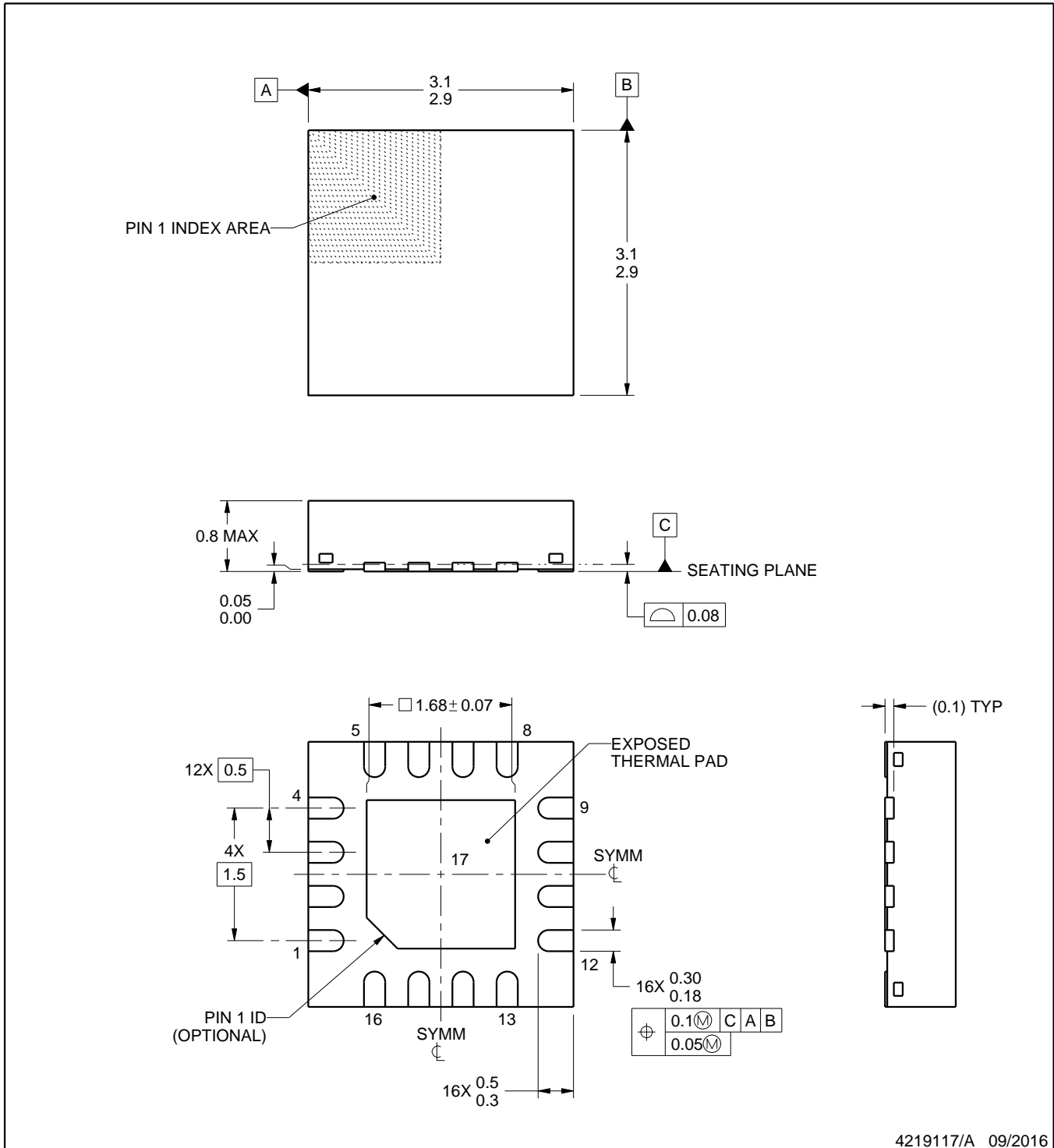

4219117/A 09/2016

NOTES:

1. All linear dimensions are in millimeters. Any dimensions in parenthesis are for reference only. Dimensioning and tolerancing per ASME Y14.5M.
2. This drawing is subject to change without notice.
3. The package thermal pad must be soldered to the printed circuit board for thermal and mechanical performance.

# EXAMPLE BOARD LAYOUT

RTE0016C

WQFN - 0.8 mm max height

PLASTIC QUAD FLATPACK - NO LEAD

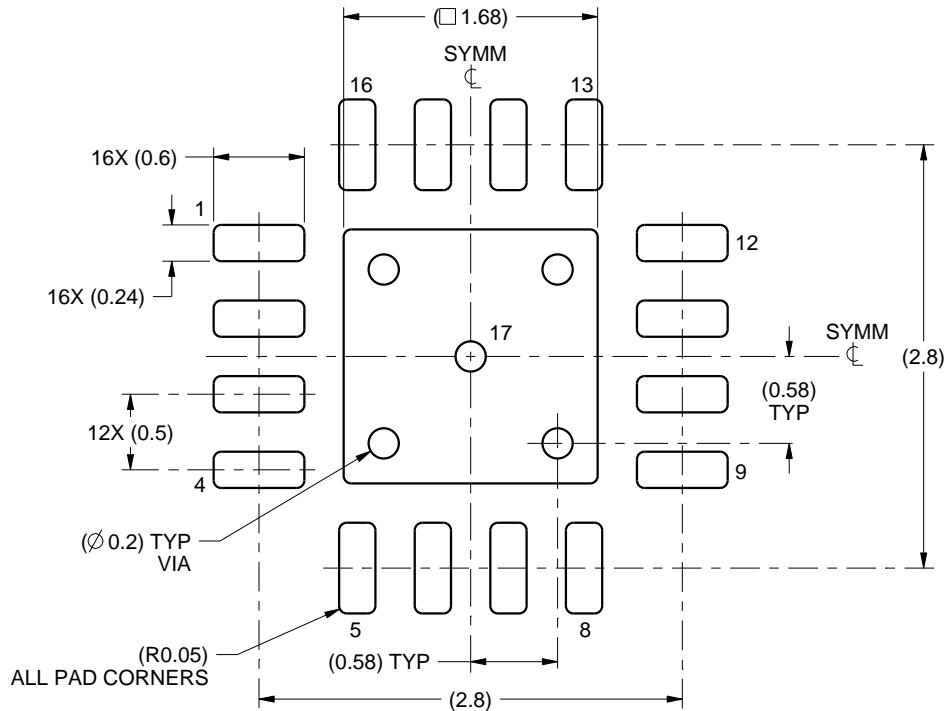

LAND PATTERN EXAMPLE  
SCALE:20X

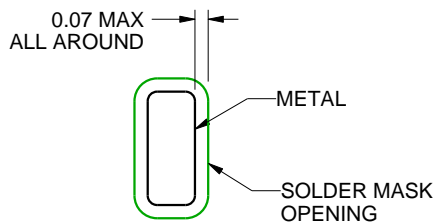

NON SOLDER MASK  
DEFINED  
(PREFERRED)

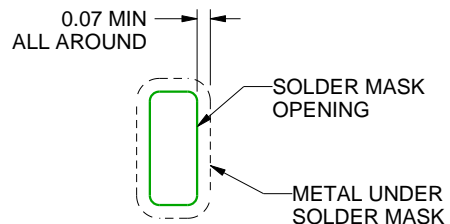

SOLDER MASK  
DEFINED

## SOLDER MASK DETAILS

4219117/A 09/2016

NOTES: (continued)

- This package is designed to be soldered to a thermal pad on the board. For more information, see Texas Instruments literature number SLUA271 ([www.ti.com/lit/slua271](http://www.ti.com/lit/slua271)).
- Vias are optional depending on application, refer to device data sheet. If any vias are implemented, refer to their locations shown on this view. It is recommended that vias under paste be filled, plugged or tented.

# EXAMPLE STENCIL DESIGN

RTE0016C

WQFN - 0.8 mm max height

PLASTIC QUAD FLATPACK - NO LEAD

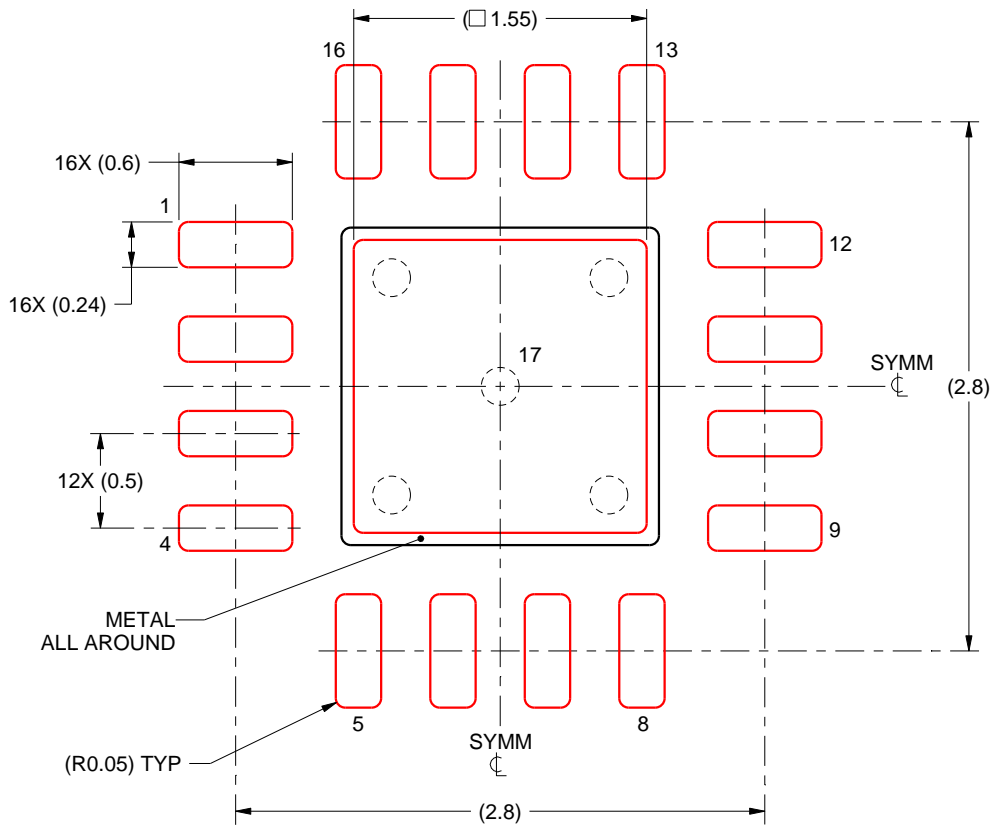

**SOLDER PASTE EXAMPLE**  
BASED ON 0.125 mm THICK STENCIL

EXPOSED PAD 17:  
85% PRINTED SOLDER COVERAGE BY AREA UNDER PACKAGE  
SCALE:25X

4219117/A 09/2016

NOTES: (continued)

6. Laser cutting apertures with trapezoidal walls and rounded corners may offer better paste release. IPC-7525 may have alternate design recommendations.

## IMPORTANT NOTICE AND DISCLAIMER

TI PROVIDES TECHNICAL AND RELIABILITY DATA (INCLUDING DATA SHEETS), DESIGN RESOURCES (INCLUDING REFERENCE DESIGNS), APPLICATION OR OTHER DESIGN ADVICE, WEB TOOLS, SAFETY INFORMATION, AND OTHER RESOURCES "AS IS" AND WITH ALL FAULTS, AND DISCLAIMS ALL WARRANTIES, EXPRESS AND IMPLIED, INCLUDING WITHOUT LIMITATION ANY IMPLIED WARRANTIES OF MERCHANTABILITY, FITNESS FOR A PARTICULAR PURPOSE OR NON-INFRINGEMENT OF THIRD PARTY INTELLECTUAL PROPERTY RIGHTS.

These resources are intended for skilled developers designing with TI products. You are solely responsible for (1) selecting the appropriate TI products for your application, (2) designing, validating and testing your application, and (3) ensuring your application meets applicable standards, and any other safety, security, regulatory or other requirements.

These resources are subject to change without notice. TI grants you permission to use these resources only for development of an application that uses the TI products described in the resource. Other reproduction and display of these resources is prohibited. No license is granted to any other TI intellectual property right or to any third party intellectual property right. TI disclaims responsibility for, and you will fully indemnify TI and its representatives against, any claims, damages, costs, losses, and liabilities arising out of your use of these resources.

TI's products are provided subject to [TI's Terms of Sale](#) or other applicable terms available either on [ti.com](http://ti.com) or provided in conjunction with such TI products. TI's provision of these resources does not expand or otherwise alter TI's applicable warranties or warranty disclaimers for TI products.

TI objects to and rejects any additional or different terms you may have proposed.

Mailing Address: Texas Instruments, Post Office Box 655303, Dallas, Texas 75265  
Copyright © 2022, Texas Instruments Incorporated