

BQ2022A 1-Kbit Serial EPROM with SDQ Interface

1 Features

- 1024 bits of one-time programmable (OTP) EPROM for storage of user-programmable configuration data
- Factory-programmed unique 64-bit identification number
- Single-wire interface to reduce circuit board routing
- Synchronous communication reduces host interrupt overhead
- 15-KV IEC 61000-4-2 ESD compliance on data pin
- No standby power required
- Available in a 3-pin SOT-23 package and TO-92 package

2 Applications

- Security encoding
- Inventory tracking
- Product-revision maintenance
- Battery-pack identification

3 Description

The BQ2022A is a 1-Kbit serial EPROM containing a factory-programmed, unique 48-bit identification number, 8-bit CRC generation, and the 8-bit family code (09h). A 64-bit status register controls write protection and page redirection.

The BQ2022A SDQ™ interface requires only a single connection and a ground return. The DATA pin is also the sole power source for the BQ2022A.

The small surface-mount package options saves printed-circuit-board space, while the low cost makes it ideal for applications such as battery pack configuration parameters, record maintenance, asset tracking, product-revision status, and access-code security.

Device Information

PART NUMBER	PACKAGE ⁽¹⁾	BODY SIZE (NOM)
BQ2022A	SOT-23 (3)	2.92 mm × 1.30 mm
	TO-92 (3)	4.30 mm × 4.30 mm

(1) For all available packages, see the orderable addendum at the end of the data sheet.

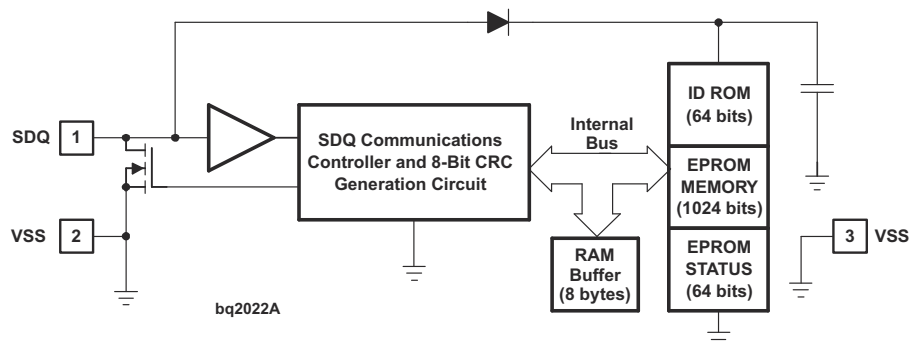

Simplified Schematic



Table of Contents

1 Features	1	7.5 Programming.....	8
2 Applications	1	8 Application and Implementation	17
3 Description	1	8.1 Application Information.....	17
4 Revision History	2	8.2 Typical Application.....	17
5 Pin Configuration and Functions	3	9 Power Supply Recommendations	19
6 Specifications	3	10 Layout	19
6.1 Absolute Maximum Ratings.....	3	10.1 Layout Guidelines.....	19
6.2 ESD Ratings.....	3	10.2 Layout Example.....	20
6.3 Recommended Operating Conditions.....	3	11 Device and Documentation Support	21
6.4 Thermal Information.....	4	11.1 Third-Party Products Disclaimer.....	21
6.5 Electrical Characteristics: DC.....	4	11.2 Documentation Support.....	21
6.6 Switching Characteristics: AC.....	4	11.3 Trademarks.....	21
6.7 Typical Characteristics.....	5	11.4 Support Resources.....	21
7 Detailed Description	5	11.5 Electrostatic Discharge Caution.....	21
7.1 Overview.....	5	11.6 Glossary.....	21
7.2 Functional Block Diagram.....	6	12 Mechanical, Packaging, and Orderable Information	21
7.3 Feature Description.....	6		
7.4 Device Functional Modes.....	8		

4 Revision History

NOTE: Page numbers for previous revisions may differ from page numbers in the current version.

Changes from Revision E (March 2016) to Revision F (January 2022)	Page
• Updated Pin Configuration and Functions	3

Changes from Revision D (December 2014) to Revision E (February 2016)	Page
• Added text: "No additional capacitance..." to Section 8.2	17
• Added Section 8.2.2.2	18
• Added text and Figure 9-1 to Section 9	19

5 Pin Configuration and Functions

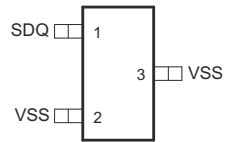

Figure 5-1. DBZ Package 3-Pin SOT-23 (Top View)

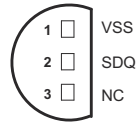

Figure 5-2. LP Package 3-Pin TO-92 (Bottom View)

Table 5-1. Pin Functions

NAME	PIN		TYPE	DESCRIPTION
	SOT-23	TO-92		
SDQ	1	2	I	Data
VSS	2, 3	1	—	Ground. Both pins should be connected to system ground.
NC	—	3	—	No connection. This pin should be connected to system ground or left floating.

6 Specifications

6.1 Absolute Maximum Ratings

over operating free-air temperature range (unless otherwise noted) ⁽¹⁾

	MIN	MAX	UNIT
DC voltage applied to data, V_{PU}	-0.3	7	V
Low-level output current, I_{OL}		40	mA
ESD IEC 61000-4-2 air discharge, data to V_{SS} , V_{SS} to data		15	kV
Operating free-air temperature, T_A	-20	70	°C
Communication free-air temperature, $T_{A(Comm)}$ ⁽²⁾	-40	85	°C
Junction temperature, T_J		125	°C
Storage temperature, T_{stg}	-55	125	°C

- (1) Operation outside the Absolute Maximum Ratings may cause permanent device damage. Absolute Maximum Ratings do not imply functional operation of the device at these or any other conditions beyond those listed under Recommended Operating Conditions. If outside the Recommended Operating Conditions but within the Absolute Maximum Ratings, the device may not be fully functional, and this may affect device reliability, functionality, performance, and shorten the device lifetime.
- (2) Communication is specified by design.

6.2 ESD Ratings

		VALUE	UNIT
$V_{(ESD)}$	Electrostatic discharge	Human body model (HBM), per ANSI/ESDA/JEDEC JS-001 ⁽¹⁾	V
		Charged device model (CDM), per JEDEC specification JESD22-C101 ⁽²⁾	

- (1) JEDEC document JEP155 states that 500-V HBM allows safe manufacturing with a standard ESD control process.
- (2) JEDEC document JEP157 states that 250-V CDM allows safe manufacturing with a standard ESD control process.

6.3 Recommended Operating Conditions

over operating free-air temperature range (unless otherwise noted)

	MIN	NOM	MAX	UNIT
V_{PU}		Operational pullup voltage	5.5	V

6.3 Recommended Operating Conditions (continued)

over operating free-air temperature range (unless otherwise noted)

		MIN	NOM	MAX	UNIT
R _{PU}	Serial communication interface pullup resistance		5		kΩ

6.4 Thermal Information

THERMAL METRIC ⁽¹⁾		BQ2022A		UNIT
		DBZ (3 PINS)	LP (3 PINS)	
R _{θJA}	Junction-to-ambient thermal resistance	244.3	158.5	°C/W
R _{θJC(top)}	Junction-to-case (top) thermal resistance	104.9	55.6	
R _{θJB}	Junction-to-board thermal resistance	93.1	n/a	
ψ _{JT}	Junction-to-top characterization parameter	4.8	26.8	
ψ _{JB}	Junction-to-board characterization parameter	66.4	137.8	
R _{θJC(bot)}	Junction-to-case (bottom) thermal resistance	n/a	n/a	

(1) For more information about traditional and new thermal metrics, see the [IC Package Thermal Metrics Application Report \(SPRA953\)](#).

6.5 Electrical Characteristics: DC

T_A = –20°C to 70°C; V_{PU(min)} = 2.65 V_{DC} to 5.5 V_{DC}, all voltages relative to VSS

PARAMETER		TEST CONDITIONS	MIN	TYP	MAX	UNIT
I _{DATA}	Supply current	V _{PU} = 5.5 V			20	μA
V _{OL}	Low-level output voltage	Logic 0, V _{PU} = 5.5 V, I _{OL} = 4 mA, SDQ pin			0.4	V
		Logic 0, V _{PU} = 2.65 V, I _{OL} = 2 mA			0.4	
V _{OH}	High-level output voltage	Logic 1		V _{PU}	5.5	
I _{OL}	Low-level output current (sink)	V _{OL} = 0.4 V, SDQ pin			4	mA
V _{IL}	Low-level input voltage	Logic 0			0.8	V
V _{IH}	High-level input voltage	Logic 1	2.2			V
V _{PP}	Programming voltage		11.5		12	V

6.6 Switching Characteristics: AC

T_A = –20°C to 70°C; V_{PU(min)} = 2.65 V_{DC} to 5.5 V_{DC}, all voltages relative to VSS

PARAMETER		TEST CONDITIONS	MIN	MAX	UNIT
t _c	Bit cycle time ⁽¹⁾		60	120	μs
t _{WSTRB}	Write start cycle ⁽¹⁾		1	15	μs
t _{WDSU}	Write data setup ⁽¹⁾		t _{WSTRB}	15	μs
t _{WDH}	Write data hold ⁽¹⁾⁽²⁾		60	t _c	μs
t _{rec}	Recovery time ⁽¹⁾		1		μs
		For memory command only	5		
t _{RSTRB}	Read start cycle ⁽¹⁾		1	13	μs
t _{ODD}	Output data delay ⁽¹⁾		t _{RSTRB}	13	μs
t _{ODHO}	Output data hold ⁽¹⁾		17	60	μs
t _{RST}	Reset time ⁽¹⁾		480		μs
t _{PPD}	Presence pulse delay ⁽¹⁾		15	60	μs
t _{PP}	Presence pulse ⁽¹⁾		60	240	μs
t _{EPROG}	EPROM programming time		2500		μs
t _{PSU}	Program setup time		5		μs
t _{PREC}	Program recovery time		5		μs

6.6 Switching Characteristics: AC (continued)

$T_A = -20^{\circ}\text{C}$ to 70°C ; $V_{PU(\text{min})} = 2.65 V_{DC}$ to $5.5 V_{DC}$, all voltages relative to V_{SS}

PARAMETER		TEST CONDITIONS	MIN	MAX	UNIT
t_{PRE}	Program rising-edge time			5	μs
t_{PFE}	Program falling-edge time			5	μs
t_{RSTREC}			480		μs

- 5-k Ω series resistor between SDQ pin and V_{PU} . (See [Figure 8-1](#).)
- t_{WDH} must be less than t_c to account for recovery.

6.7 Typical Characteristics

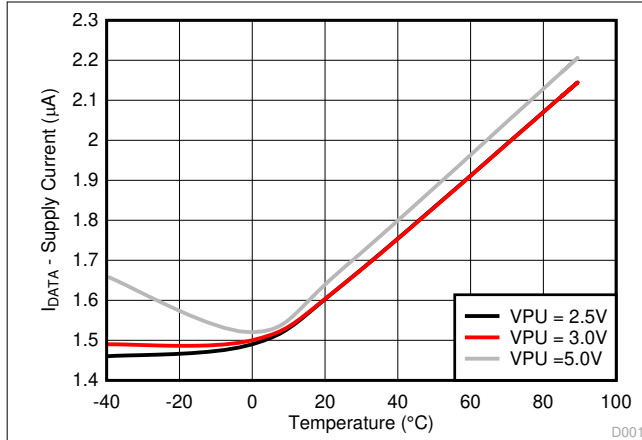

Figure 6-1. Supply Current vs Temperature

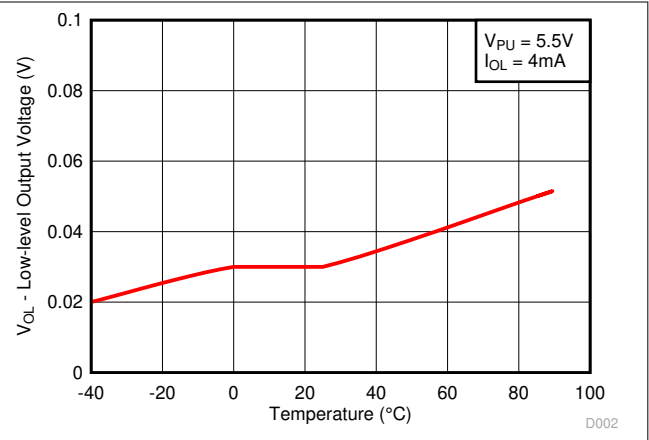

Figure 6-2. Low-Level Output Voltage vs Temperature

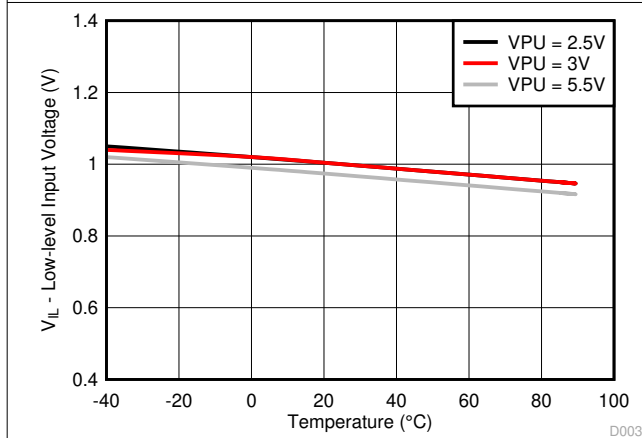

Figure 6-3. Low-Level Input Voltage vs Temperature

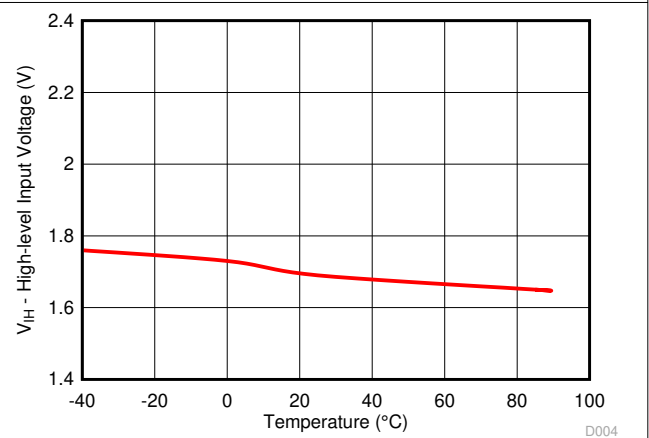

Figure 6-4. High-Level Input Voltage vs Temperature

7 Detailed Description

7.1 Overview

[Section 7.2](#) shows the relationships among the major control and memory sections of the BQ2022A. The BQ2022A has three main data components: a 64-bit factory-programmed ROM, including 8-bit family code, 48-bit identification number and 8-bit CRC value, 1024-bit EPROM, and EPROM STATUS bytes. Power for read and write operations is derived from the DATA pin. An internal capacitor stores energy while the signal line is high and releases energy during the low times of the DATA pin, until the pin returns high to replenish the charge on the capacitor. A special manufacturer's PROGRAM PROFILE BYTE can be read to determine the programming profile required to program the part.

7.2 Functional Block Diagram

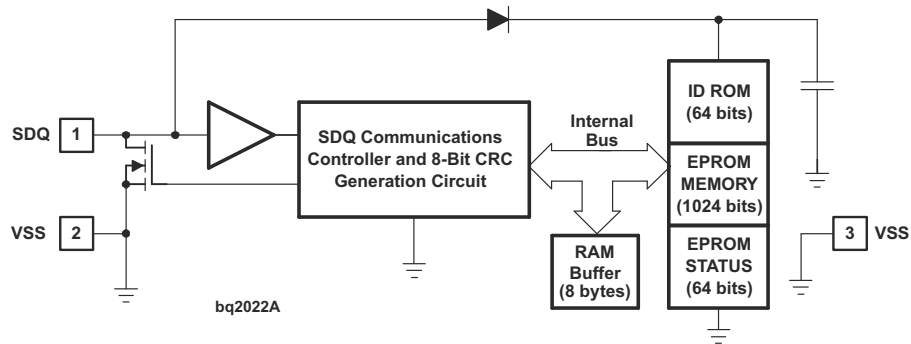

7.3 Feature Description

7.3.1 1024-Bit EPROM

Table 7-1 is a memory map of the 1024-bit EPROM section of the BQ2022A, configured as four pages of 32 bytes each. The 8-byte RAM buffers are additional registers used when programming the memory. Data are first written to the RAM buffer and then verified by reading an 8-bit CRC from the BQ2022A that confirms proper receipt of the data. If the buffer contents are correct, a programming command is issued and an 8-byte segment of data is written into the selected address in memory. This process ensures data integrity when programming the memory. The details for reading and programming the 1024-bit EPROM portion of the BQ2022A are in Section 7.5.4 section of this data sheet.

Table 7-1. 1024-Bit EPROM Data Memory Map

ADDRESS(HEX)	PAGE
0060-007F	Page 3
0040-005F	Page 2
0020-003F	Page 1
0000-001F	Page 0

7.3.2 EPROM Status Memory

In addition to the programmable 1024-bits of memory are 64 bits of status information contained in the EPROM STATUS memory. The STATUS memory is accessible with separate commands. The STATUS bits are EPROM and are read or programmed to indicate various conditions to the software interrogating the BQ2022A. The first byte of the STATUS memory contains the write protect page bits, that inhibit programming of the corresponding page in the 1024-bit main memory area if the appropriate write-protection bit is programmed. Once a bit has been programmed in the write protect page byte, the entire 32-byte page that corresponds to that bit can no longer be altered but may still be read. The write protect bits may be cleared by using the WRITE STATUS command.

The next four bytes of the EPROM STATUS memory contain the page address redirection bytes. Bits in the EPROM status bytes can indicate to the host what page is substituted for the page by the appropriate redirection byte. The hardware of the BQ2022A makes no decisions based on the contents of the page address redirection bytes. This feature allows the user's software to make a data patch to the EPROM by indicating that a particular page or pages should be replaced with those indicated in the page address redirection bytes. The ones complement of the new page address is written into the page address redirection byte that corresponds to the original (replaced) page. If a page address redirection byte has an FFh value, the data in the main memory that corresponds to that page are valid. If a page address redirection byte has some other hex value, the data in the page corresponding to that redirection byte are invalid, and the valid data can now be found at the ones complement of the page address indicated by the hexadecimal value stored in the associated page address redirection byte. A value of FDh in the redirection byte for page 1, for example, indicates that the updated data are now in page 2. The details for reading and programming the EPROM status memory portion of the BQ2022A are given in [Section 7.5.4](#) section.

Table 7-2. EPROM Status Bytes

ADDRESS (HEX)	PAGE
00h	Write protection bits BIT0—write protect page 0 BIT1—write protect page 1 BIT2—write protect page 2 BIT3—write protect page 3 BIT4 to 7—bitmap of used pages
01h	Redirection byte for page 0
02h	Redirection byte for page 1
03h	Redirection byte for page 2
04h	Redirection byte for page 3
05h	Reserved
06h	Reserved
07h	Factory programmed 00h

7.3.3 Error Checking

To validate the data transmitted from the BQ2022A, the host generates a CRC value from the data as they are received. This generated value is compared to the CRC value transmitted by the BQ2022A. If the two CRC values match, the transmission is error-free. The equivalent polynomial function of this CRC is $X^8 + X^5 + X^4 + 1$. [Section 7.5.16](#) provides details.

7.3.4 Customizing the BQ2022A

The 64-bit ID identifies each BQ2022A. The 48-bit serial number is unique and programmed by Texas Instruments. The default 8-bit family code is 09h; however, a different value can be reserved on an individual customer basis. Contact your Texas Instruments sales representative for more information.

7.3.5 Bus Termination

Because the drive output of the BQ2022A is an open-drain, N-channel MOSFET, the host must provide a source current or a 5-kΩ external pullup, as shown in the typical application circuit in [Figure 8-1](#).

7.4 Device Functional Modes

The device is in active mode during SDQ communication or while the SDQ is kept at valid V_{PU} voltages.

7.5 Programming

7.5.1 Serial Communication

A host reads, programs, or checks the status of the BQ2022A through the command structure of the SDQ interface.

7.5.2 Initialization

Initialization consists of two pulses, the RESET and the PRESENCE pulses. The host generates the RESET pulse, while the BQ2022A responds with the PRESENCE pulse. The host resets the BQ2022A by driving the DATA bus low for at least 480 μ s. For more details, see [Section 7.5.11](#).

7.5.3 ROM Commands

7.5.3.1 READ ROM Command

The READ ROM command sequence is the fastest sequence that allows the host to read the 8-bit family code and 48-bit identification number. The READ ROM sequence starts with the host generating the RESET pulse of at least 480 μ s. The BQ2022A responds with a PRESENCE pulse. Next, the host continues by issuing the READ ROM command, 33h, and then reads the ROM and CRC byte using the READ signaling (see the READ and WRITE signals section) during the data frame.

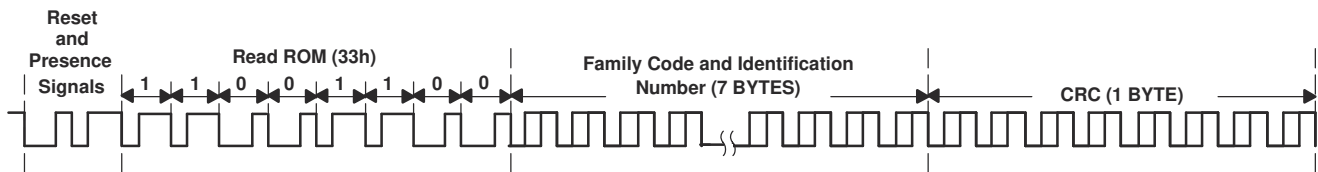

Figure 7-1. READ ROM Sequence

7.5.3.2 SKIP ROM Command

This SKIP ROM command, CCh, allows the host to access the memory/status functions. The SKIP ROM command is directly followed by a memory/status functions command.

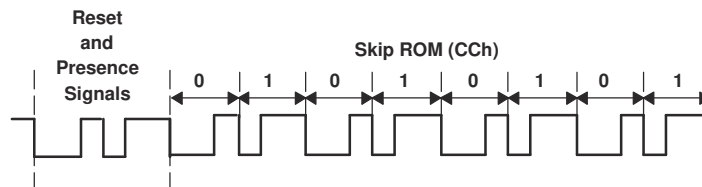

Figure 7-2. SKIP ROM Sequence

7.5.4 Memory/Status Function Commands

Six memory/status function commands allow read and modification of the 1024-bit EPROM data memory or the 64-bit EPROM status memory. There are two types of READ MEMORY command, plus the WRITE MEMORY, READ STATUS, and WRITE STATUS commands. Additionally, the part responds to a PROGRAM PROFILE byte command. The BQ2022A responds to memory/status function commands only after a part is issued a SKIP ROM command.

7.5.5 READ MEMORY Commands

Two READ MEMORY commands are available on the BQ2022A. Both commands are used to read data from the 1024-bit EPROM data field. They are the READ MEMORY/Page CRC and the READ MEMORY/Field CRC commands. The READ MEMORY/Page CRC generates CRC at the end any 32-byte page boundary whereas the READ MEMORY/Field CRC generates CRC when the end of the 1024-bit data memory is reached.

7.5.5.1 READ MEMORY/Page CRC

To read memory and generate the CRC at the 32-byte page boundaries of the BQ2022A, the SKIP ROM command is followed by the READ MEMORY/Generate CRC command, C3h, followed by the address low byte and then the address high byte.

An 8-bit CRC of the command byte and address bytes is computed by the BQ2022A and read back by the host to confirm that the correct command word and starting address were received. If the CRC read by the host is incorrect, a reset pulse must be issued and the entire sequence must be repeated. If the CRC received by the host is correct, the host issues read time slots and receives data from the BQ2022A starting at the initial address and continuing until the end of a 32-byte page is reached. At that point, the host sends eight additional read time slots and receive an 8-bit CRC that is the result of shifting into the CRC generator all of the data bytes from the initial starting byte to the last byte of the current page. Once the 8-bit CRC has been received, data is again read from the 1024-bit EPROM data field starting at the next page. This sequence continues until the final page and its accompanying CRC are read by the host. Thus each page of data can be considered to be 33 bytes long, the 32 bytes of user-programmed EPROM data and an 8-bit CRC that gets generated automatically at the end of each page.

Figure 7-3. READ MEMORY/Page CRC

Initialization and SKIP ROM Command Sequence	READ MEMORY/ Generate CRC Command C3h	Address Low Byte A0 A7		Address High Byte A8 A15		Read and Verify CRC	EPROM Memory and CRC Byte Generated at 32-Byte Page Boundaries
--	--	--	--	---	--	------------------------	--

NOTE: Individual bytes of address and data are transmitted LSB first.

7.5.5.2 READ MEMORY/Field CRC

To read memory without CRC generation on 32-byte page boundaries, the SKIP ROM command is followed by the READ MEMORY command, F0h, followed by the address low byte and then the address high byte.

Note

As shown in [Figure 7-4](#), individual bytes of address and data are transmitted LSB first.

An 8-bit CRC of the command byte and address bytes is computed by the BQ2022A and read back by the host to confirm that the correct command word and starting address were received. If the CRC read by the host is incorrect, a reset pulse must be issued and the entire sequence must be repeated. If the CRC received by the host is correct, the host issues read time slots and receives data from the BQ2022A starting at the initial address and continuing until the end of the 1024-bit data field is reached or until a reset pulse is issued. If reading occurs through the end of memory space, the host may issue eight additional read time slots and the BQ2022A responds with an 8-bit CRC of all data bytes read from the initial starting byte through the last byte of memory. After the CRC is received by the host, any subsequent read time slots appear as logical 1s until a reset pulse is issued. Any reads ended by a reset pulse prior to reaching the end of memory does not have the 8-bit CRC available.

Figure 7-4. READ MEMORY/Field CRC

Initialization and SKIP ROM Command Sequence	READ MEMORY Command F0h	Address Low Byte A0	Address High Byte A7	Address High Byte A8	Address High Byte A15	Read and Verify CRC	Read EPROM Memory Until End of EPROM Memory	Read and Verify CRC
--	-------------------------	------------------------	-------------------------	-------------------------	--------------------------	---------------------	---	---------------------

7.5.6 WRITE MEMORY Command

The WRITE MEMORY command is used to program the 1024-bit EPROM memory field. The 1024-bit memory field is programmed in 8-byte segments. Data is first written into an 8-byte RAM buffer one byte at a time. The contents of the RAM buffer is then ANDed with the contents of the EPROM memory field when the programming command is issued.

Figure 7-5 illustrates the sequence of events for programming the EPROM memory field. After issuing a SKIP ROM command, the host issues the WRITE MEMORY command, 0Fh, followed by the low byte and then the high byte of the starting address. The BQ2022A calculates and transmits an 8-bit CRC based on the WRITE command and address.

If at any time during the WRITE MEMORY process, the CRC read by the host is incorrect, a reset pulse must be issued, and the entire sequence must be repeated.

After the BQ2022A transmits the CRC, the host then transmits 8 bytes of data to the BQ2022A. Another 8-bit CRC is calculated and transmitted based on the 8 bytes of data. If this CRC agrees with the CRC calculated by the host, the host transmits the program command 5Ah and then applies the programming voltage for at least 2500 μ s or t_{EPROM} . The contents of the RAM buffer is then logically ANDed with the contents of the 8-byte EPROM offset by the starting address.

The starting address can be any integer multiple of eight between 0000 and 007F (hex) such as 0000, 0008, and 0010 (hex).

The WRITE DATA MEMORY command sequence can be terminated at any point by issuing a reset pulse except during the program pulse period t_{PROG} .

Note

The BQ2022A responds with the data from the selected EPROM address sent least significant-bit first. This response should be checked to verify the programmed byte. If the programmed byte is incorrect, then the host must reset the part and begin the write sequence again.

For both of these cases, the decision to continue programming is made entirely by the host, because the BQ2022A is not able to determine if the 8-bit CRC calculated by the host agrees with the 8-bit CRC calculated by the BQ2022A.

Prior to programming, bits in the 1024-bit EPROM data field appear as logical 1 s.

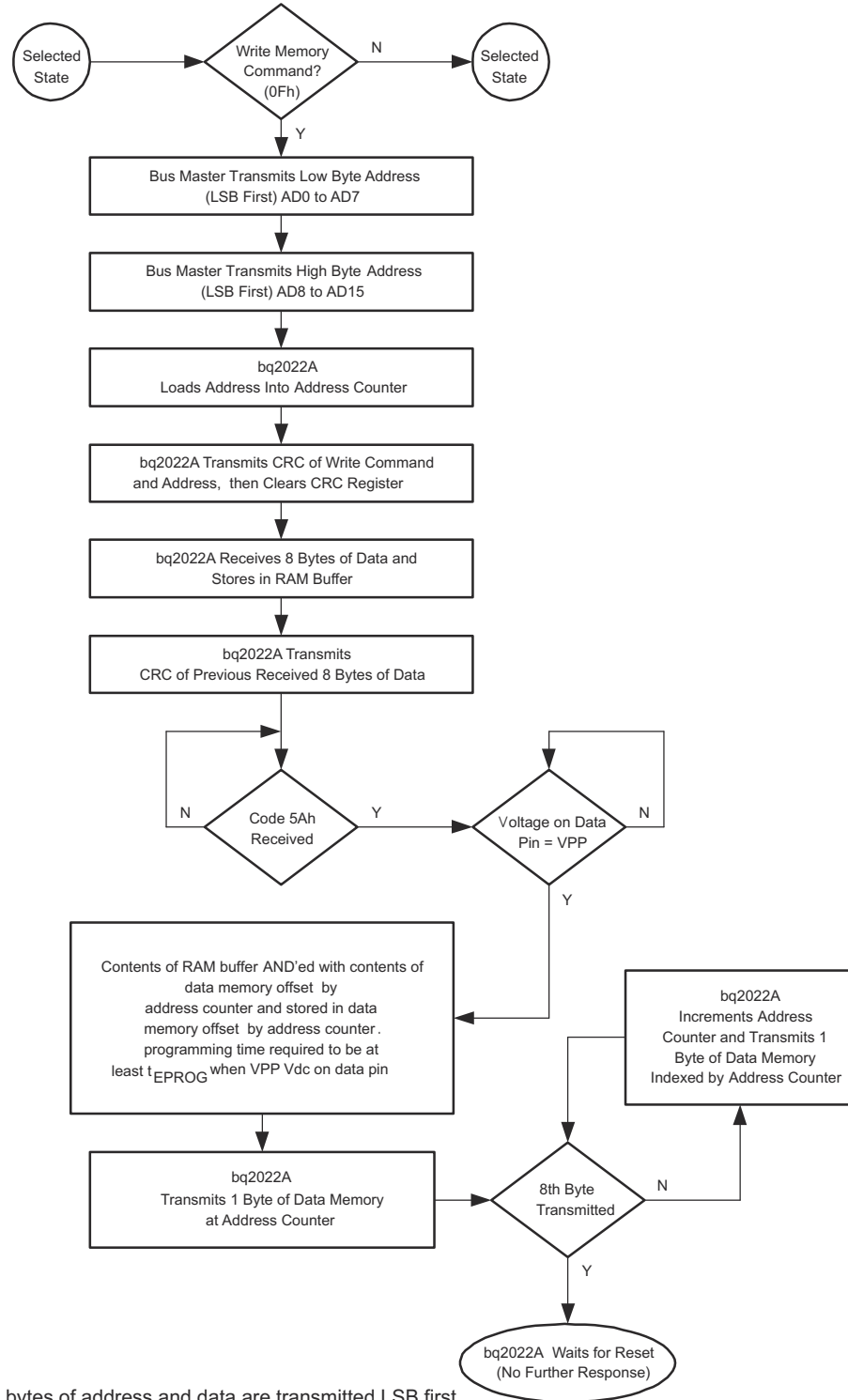

NOTE: Individual bytes of address and data are transmitted LSB first

Figure 7-5. WRITE MEMORY Command Flow

7.5.7 READ STATUS Command

The READ STATUS command is used to read data from the EPROM status data field. After issuing a SKIP ROM command, the host issues the READ STATUS command, AAh, followed by the address low byte and then the address high byte.

Note

An 8-bit CRC of the command byte and address bytes is computed by the BQ2022A and read back by the host to confirm that the correct command word and starting address were received.

If the CRC read by the host is incorrect, a reset pulse must be issued and the entire sequence must be repeated. If the CRC received by the host is correct, the host issues read time slots and receives data from the BQ2022A starting at the supplied address and continuing until the end of the EPROM Status data field is reached. At that point, the host receives an 8-bit CRC that is the result of shifting into the CRC generator all of the data bytes from the initial starting byte through the final factory-programmed byte that contains the 00h value.

This feature is provided because the EPROM status information may change over time making it impossible to program the data once and include an accompanying CRC that is always valid. Therefore, the READ status command supplies an 8-bit CRC that is based on (and always is consistent with) the current data stored in the EPROM status data field.

After the 8-bit CRC is read, the host receives logical 1s from the BQ2022A until a reset pulse is issued. The READ STATUS command sequence can be ended at any point by issuing a reset pulse.

Figure 7-6. READ STATUS Command

Initialization and SKIP ROM Command Sequence	READ MEMORY Command AAh	Address Low Byte A0 A7	Address High Byte A8 A15	Read and Verify CRC	Read STATUS Memory Until End of STATUS Memory	Read and Verify CRC
--	----------------------------	--------------------------------	----------------------------------	---------------------	---	---------------------

7.5.8 WRITE STATUS Command

The WRITE STATUS command is used to program the EPROM Status data field after the BQ2022A has been issued SKIP ROM command.

The flow chart in [Figure 7-7](#) illustrates that the host issues the WRITE STATUS command, 55h, followed by the address low byte and then the address high byte the followed by the byte of data to be programmed.

Note

Individual bytes of address and data are transmitted LSB first. An 8-bit CRC of the command byte, address bytes, and data byte is computed by the BQ2022A and read back by the host to confirm that the correct command word, starting address, and data byte were received.

If the CRC read by the host is incorrect, a reset pulse must be issued and the entire sequence must be repeated. If the CRC received by the host is correct, the program command (5Ah) is issued. After the program command is issued, then the programming voltage, V_{PP} is applied to the DATA pin for period t_{PROG} . Prior to programming, the first seven bytes of the EPROM STATUS data field appear as logical 1s. For each bit in the data byte provided by the host that is set to a logical 0, the corresponding bit in the selected byte of the EPROM STATUS data field is programmed to a logical 0 after the programming pulse has been applied at the byte location. The eighth byte of the EPROM STATUS byte data field is factory-programmed to contain 00h.

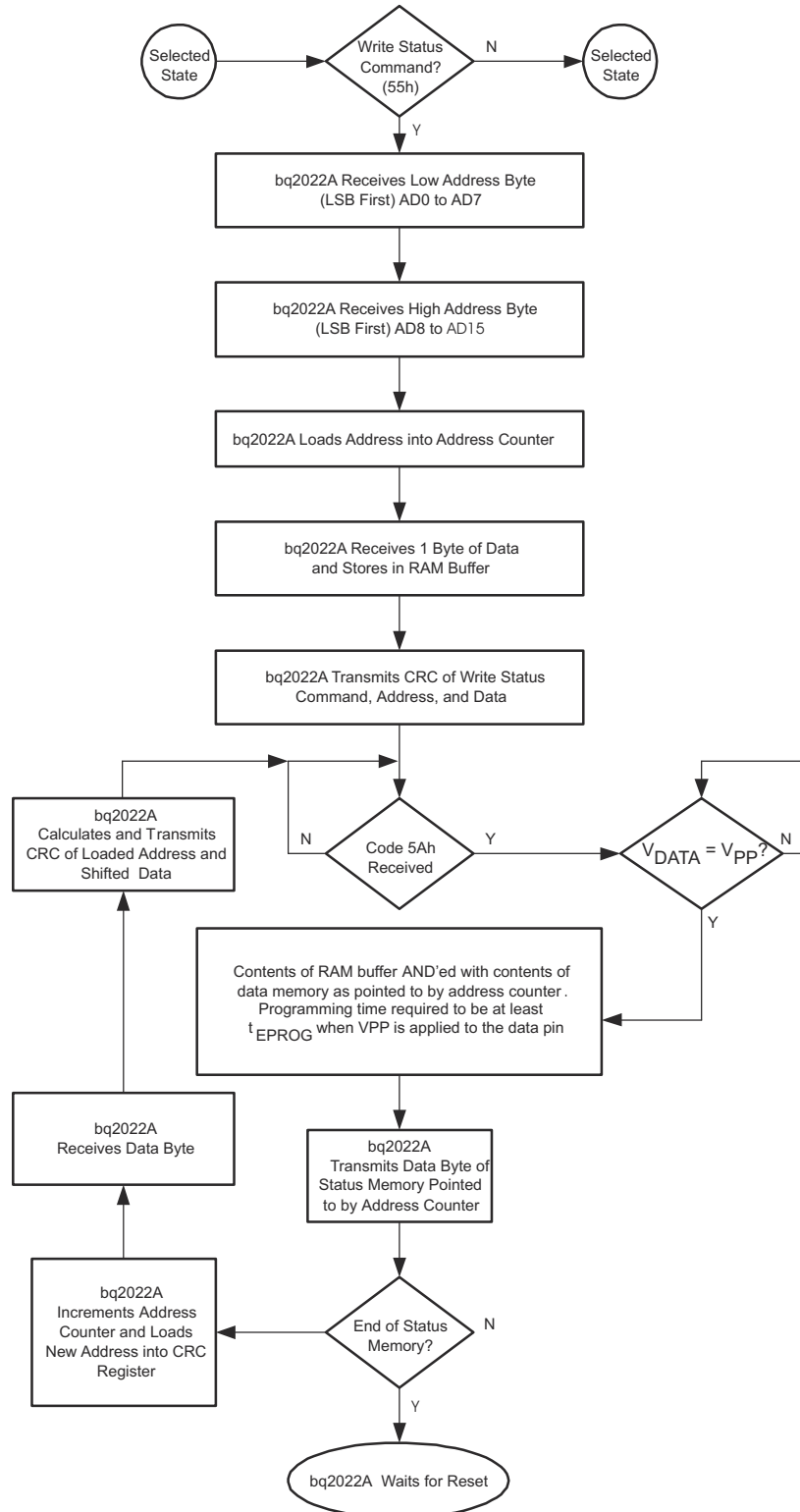

Figure 7-7. WRITE STATUS Command Flow

After the programming pulse is applied and the data line returns to V_{PU} , the host issues eight read time slots to verify that the appropriate bits have been programmed. The BQ2022A responds with the data from the selected EPROM STATUS address sent least significant bit first. This response should be checked to verify the programmed byte. If the programmed byte is incorrect, then the host must reset the device and begin the write

sequence again. If the BQ2022A EPROM data byte programming was successful, the BQ2022A automatically increments its address counter to select the next byte in the STATUS MEMORY data field. The least significant byte of the new two-byte address is also loaded into the 8-bit CRC generator as a starting value. The host issues the next byte of data using eight write time slots.

As the BQ2022A receives this byte of data into the RAM buffer, it also shifts the data into the CRC generator that has been preloaded with the LSB of the current address and the result is an 8-bit CRC of the new data byte and the LSB of the new address. After supplying the data byte, the host reads this 8-bit CRC from the BQ2022A with eight read time slots to confirm that the address incremented properly and the data byte was received correctly. If the CRC is incorrect, a Reset Pulse must be issued and the Write Status command sequence must be restarted. If the CRC is correct, the host issues a programming pulse and the selected byte in memory is programmed.

Note

The initial write of the WRITE STATUS command, generates an 8-bit CRC value that is the result of shifting the command byte into the CRC generator, followed by the two-address bytes, and finally the data byte. Subsequent writes within this WRITE STATUS command due to the BQ2022A automatically incrementing its address counter generates an 8-bit CRC that is the result of loading (not shifting) the LSB of the new (incremented) address into the CRC generator and then shifting in the new data byte.

For both of these cases, the decision to continue programming the EPROM Status registers is made entirely by the host, because the BQ2022A is not able to determine if the 8-bit CRC calculated by the host agrees with the 8-bit CRC calculated by the BQ2022A. If an incorrect CRC is ignored and a program pulse is applied by the host, incorrect programming could occur within the BQ2022A. Also note that the BQ2022A always increments its internal address counter after the receipt of the eight read time slots used to confirm the programming of the selected EPROM byte. The decision to continue is again made entirely by the host, therefore if the EPROM data byte does not match the supplied data byte but the master continues with the WRITE STATUS command, incorrect programming could occur within the BQ2022A. The WRITE STATUS command sequence can be ended at any point by issuing a reset pulse.

Table 7-3. Command Code Summary

COMMAND (HEX)	DESCRIPTION	CATEGORY
33h	Read Serialization ROM and CRC	ROM Commands Available in Command Level I
CCh	Skip Serialization ROM	
F0h	Read Memory/Field CRC	Memory Function Commands Available in Command Level II
AAh	Read EPROM Status	
C3h	Read Memory/Page CRC	
0Fh	Write Memory	
99h	Programming Profile	
55h	Write EPROM Status	Program Command Available Only in WRITE MEMORY and WRITE STATUS Modes
5Ah	Program Control	

7.5.9 PROGRAM PROFILE Byte

The PROGRAM PROFILE byte is read to determine the WRITE MEMORY programming sequence required by a specific manufacturer. After issuing a ROM command, the host issues the PROGRAM PROFILE BYTE command, 99h. [Figure 7-8](#) shows the BQ2022A responds with 55h. This informs the host that the WRITE MEMORY programming sequence is the one described in [Section 7.5.6](#).

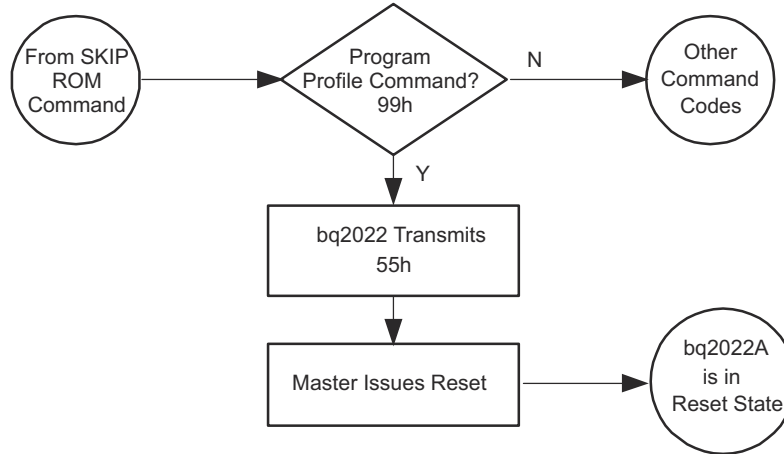

Figure 7-8. PROGRAM PROFILE Command Flow

7.5.10 SDQ Signaling

All SDQ signaling begins with initializing the device, followed by the host driving the bus low to write a 1 or 0, or to begin the start frame for a bit read. Figure 7-9 shows the initialization timing, whereas Figure 7-10 and Figure 7-11 show that the host initiates each bit by driving the DATA bus low for the start period, t_{WSTRB} / t_{RSTRB} . After the bit is initiated, either the host continues controlling the bus during a WRITE, or the BQ2022A responds during a READ.

7.5.11 RESET and PRESENCE PULSE

If the DATA bus is driven low for more than 120 μ s, the BQ2022A may be reset. Figure 7-9 shows that if the DATA bus is driven low for more than 480 μ s, the BQ2022A resets and indicates that it is ready by responding with a PRESENCE PULSE.

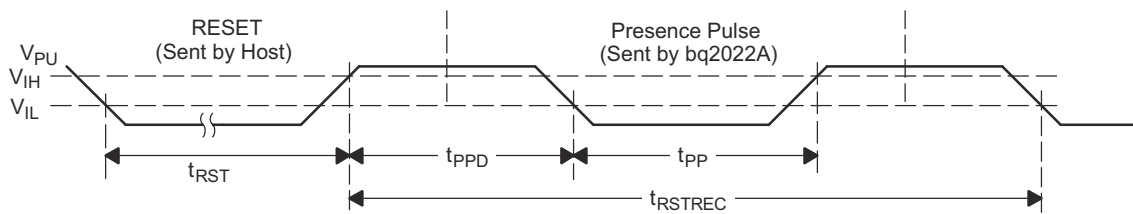

Figure 7-9. Reset Timing Diagram

7.5.12 WRITE Bit

The WRITE bit timing diagram in Figure 7-10 shows that the host initiates the transmission by issuing the t_{WSTRB} portion of the bit and then either driving the DATA bus low for a WRITE 0, or releasing the DATA bus for a WRITE 1.

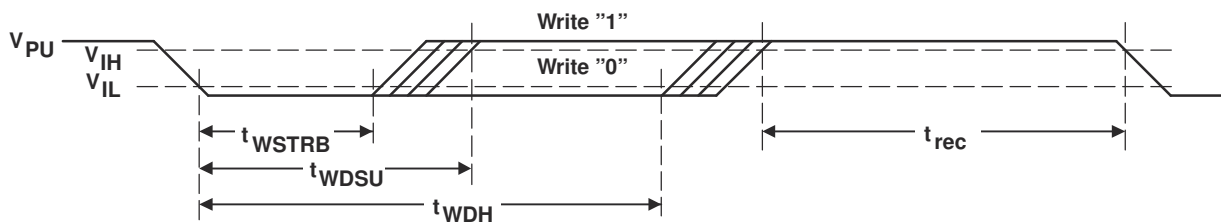

Figure 7-10. WRITE Bit Timing Diagram

7.5.13 READ Bit

The READ bit timing diagram in Figure 7-11 shows that the host initiates the transmission of the bit by issuing the t_{RSTRB} portion of the bit. The BQ2022A then responds by either driving the DATA bus low to transmit a READ 0 or releasing the DATA bus to transmit a READ 1.

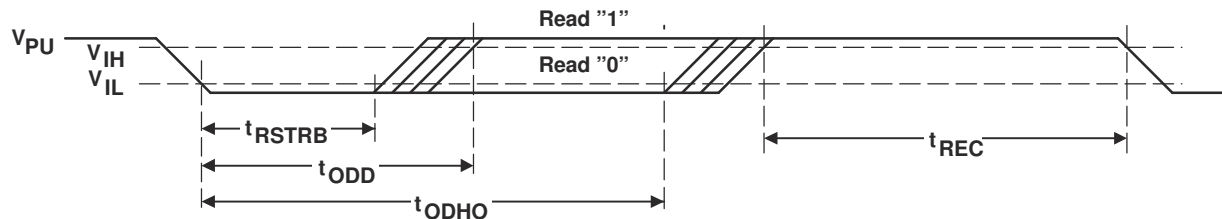

Figure 7-11. READ Bit Timing Diagram

7.5.14 PROGRAM PULSE

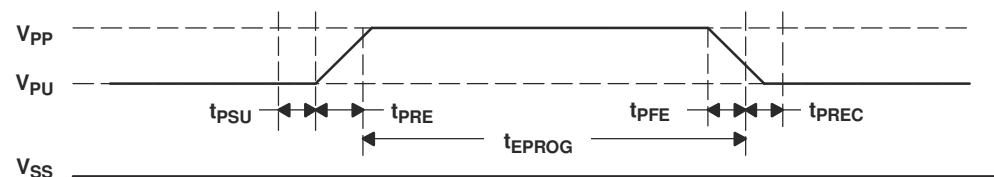

Figure 7-12. PROGRAM PULSE Timing Diagram

7.5.15 IDLE

If the bus is high, the bus is in the IDLE state. Bus transactions can be suspended by leaving the DATA bus in IDLE. Bus transactions can resume at any time from the IDLE state.

7.5.16 CRC Generation

The BQ2022A has an 8-bit CRC stored in the most significant byte of the 64-bit ROM. The bus master can compute a CRC value from the first 56 bits of the 64-bit ROM and compare it to the value stored within the BQ2022A to determine if the ROM data has been received error-free by the bus master. The equivalent polynomial function of this CRC is: $X^8 + X^5 + X^4 + 1$.

Under certain conditions, the BQ2022A also generates an 8-bit CRC value using the same polynomial function just shown and provides this value to the bus master to validate the transfer of command, address, and data bytes from the bus master to the BQ2022A. The BQ2022A computes an 8-bit CRC for the command, address, and data bytes received for the WRITE MEMORY and the WRITE STATUS commands and then outputs this value to the bus master to confirm proper transfer. Similarly, the BQ2022A computes an 8-bit CRC for the command and address bytes received from the bus master for the READ MEMORY, READ STATUS, and READ DATA/ GENERATE 8-BIT CRC commands to confirm that these bytes have been received correctly. The CRC generator on the BQ2022A is also used to provide verification of error-free data transfer as each page of data from the 1024-bit EPROM is sent to the bus master during a READ DATA/GENERATE 8-BIT CRC command, and for the eight bytes of information in the status memory field.

In each case where a CRC is used for data transfer validation, the bus master must calculate a CRC value using the polynomial function previously given and compare the calculated value to either the 8-bit CRC value stored in the 64-bit ROM portion of the BQ2022A (for ROM reads) or the 8-bit CRC value computed within the BQ2022A. The comparison of CRC values and decision to continue with an operation are determined entirely by the bus master. No circuitry on the BQ2022A prevents a command sequence from proceeding if the CRC stored in or calculated by the BQ2022A does not match the value generated by the bus master. Proper use of the CRC can result in a communication channel with a high level of integrity.

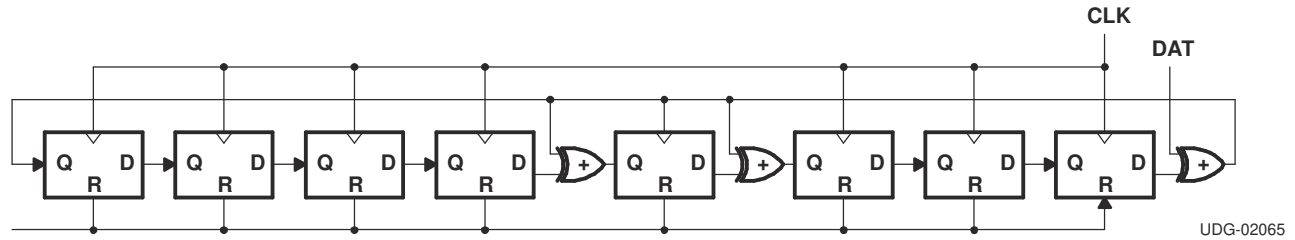

Figure 7-13. 8-Bit CRC Generator Circuit ($X^8 + X^5 + X^4 + 1$)

8 Application and Implementation

Note

Information in the following applications sections is not part of the TI component specification, and TI does not warrant its accuracy or completeness. TI's customers are responsible for determining suitability of components for their purposes, as well as validating and testing their design implementation to confirm system functionality.

8.1 Application Information

A typical application consists of a microcontroller that is configured to be a SDQ communication host device and the BQ2022A being the SDQ slave device. The host and slave have open drain functionality for which a pullup resistor (typically 10 k Ω) is required connected to a pullup voltage in the range of 2.65 V to 5.5 V.

8.2 Typical Application

No additional capacitance is needed on the SDQ line and may result in a communication failure.

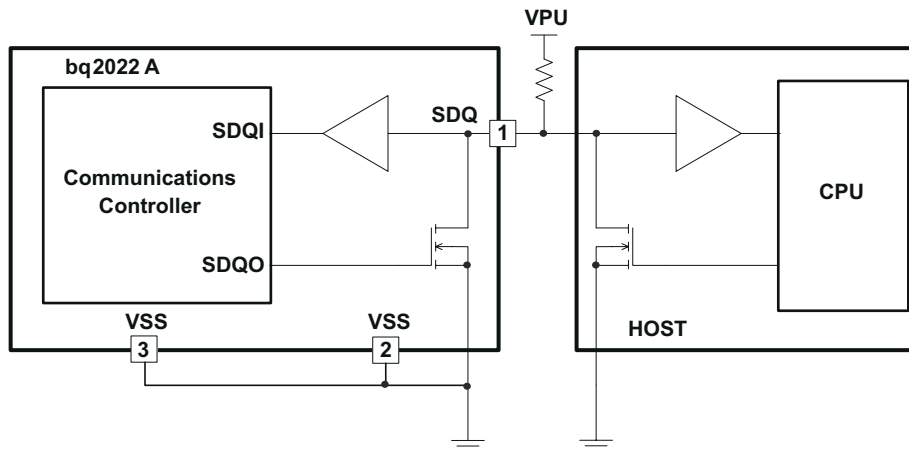

Figure 8-1. Typical Application Circuit

8.2.1 Design Requirements

Table 8-1. Design Parameters

DESIGN PARAMETER	EXAMPLE VALUE
Pullup voltage	2.65 V to 5.5 V
Operating free-air temperature	-20°C to 70°C
Pullup resistor	10 k Ω typ

8.2.2 Detailed Design Procedure

8.2.2.1 Programming Circuit Example

The BQ2022A requires a 12-V maximum pulse signal to program the OTP memory. It is necessary to have a programming test setup for production. Figure 8-2 shows an example of what the circuit could be for such setup. The Programming Module contains the microcontroller that acts as SDQ master and also controls the time of the programming pulse and its width. The 12-V supply is the source for the programming pulse. Only SDQ and VSS signals need to exit the test setup as the Application Circuit containing the BQ2022A under test is connected only for programming and verifying data.

The Programming Module typically will connect to a PC using interface such as USB. The diagram in Figure 8-2 does not include the interface to a PC which can vary depending on the system designer's choice.

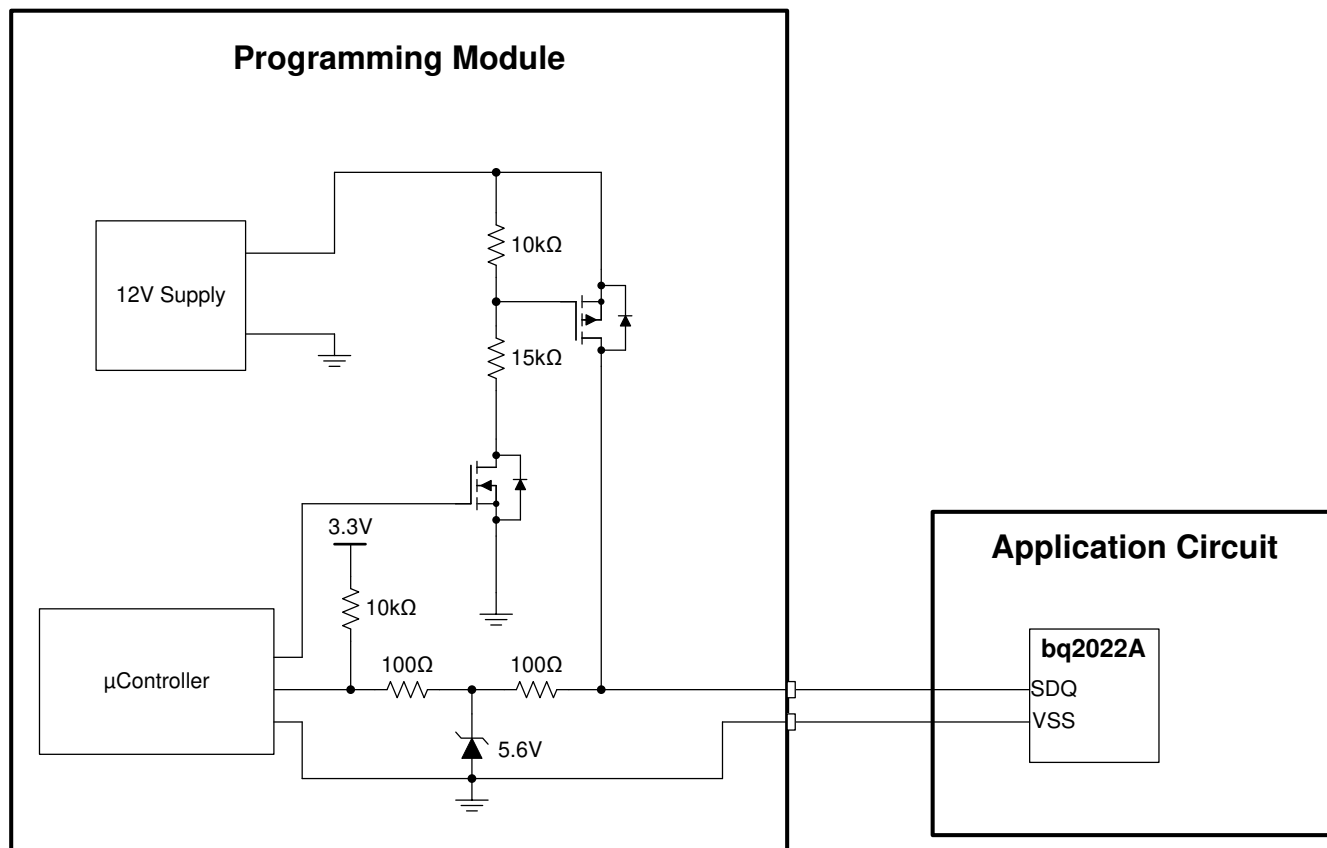

Figure 8-2. BQ2022A Programming Circuit Example

8.2.2.2 SDQ Master Best Practices

It may be necessary to “bit-bang” a GPIO on the host system to act as the SDQ master. In this case, some additional error checking should be built into the code used to reset the BQ2022A to ensure that the slave is operating as expected on the bus.

Whenever the host sends a reset, the BQ2022A responds with a presence pulse. The host should confirm, before the presence pulse, that the bus has been released and returned to a high level, indicating that nothing is holding the bus unexpectedly low. As the minimum t_{ppd} is 15 μ s, having the host look for a logic high on the bus 10 μ s after releasing the bus at the end of the reset is sufficient to confirm the bus is released for the BQ2022A to respond.

8.2.3 Application Curve

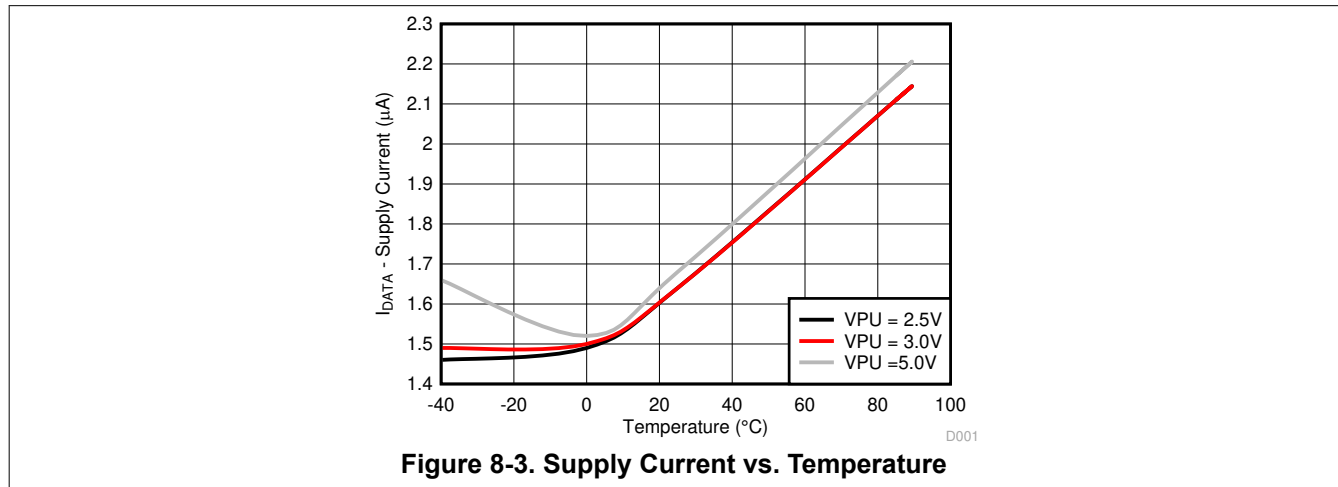

9 Power Supply Recommendations

The BQ2022A is a low-power device that only needs to be turned on when communicating. The device power comes from the voltage supply that is used for digital I/O in the system. A dedicated VCC pin does not exist in the device for which there is not a requirement of a supply input bypass capacitor. The device obtains its power from the SDQ communication input which can be sustained during normal communication activity.

The ramp time of the SDQ voltage when power is initially applied may be slow due to current limiting from the source. Ramp times greater than 200 μs might cause undesired bouncing of the POR circuit and result in the device not generating a presence pulse. To account for this undesired effect on the device a best practice for the communication master would be to issue a “hard” reset to the device by pulling down the SDQ line for >5 ms and then releasing the SDQ bus before issuing the reset pulse that is approximately 480 μs long.



Figure 9-1. Power Up Best Practice

Figure 9-1 illustrates the best practice for dealing with initial power on ramps, shown as (1) in the figure, that may be long in duration. The host should issue a “hard” reset, (2), of > 5 ms, which resets the device and generate a presence delay and presence pulse, (3). After that, a “soft” reset of approximately 480 μs can be applied, (4), which also generates a high presence delay and low presence pulse, (5).

10 Layout

10.1 Layout Guidelines

The BQ2022A only has one signal (SDQ). Best practice is to route the signal trace directly from the SDQ pin of BQ2022A to the external connector of the application system or to host SDQ master device. Signal trace should be shielded properly with a parallel ground plane. If possible use two vias per VSS pin to reach the ground plane [Figure 10-1](#). If a full ground plane is not available to the BQ2022A, then try to connect both VSS pins with a large trace surrounding most of the device and have a trace leaving the VSS pin that is adjacent to SDQ pin so that it follows the SDQ trace back to the SDQ master interface pins [Figure 10-2](#).

10.2 Layout Example

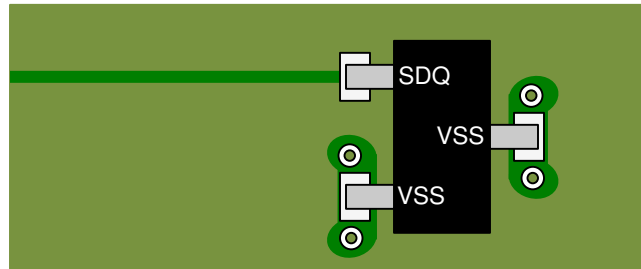

Figure 10-1. Board Layout Example with Ground Plane

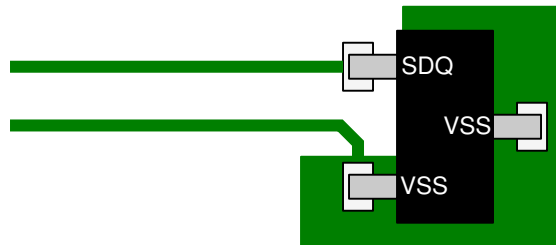

Figure 10-2. Board Layout Example without Ground Plane

11 Device and Documentation Support

11.1 Third-Party Products Disclaimer

TI'S PUBLICATION OF INFORMATION REGARDING THIRD-PARTY PRODUCTS OR SERVICES DOES NOT CONSTITUTE AN ENDORSEMENT REGARDING THE SUITABILITY OF SUCH PRODUCTS OR SERVICES OR A WARRANTY, REPRESENTATION OR ENDORSEMENT OF SUCH PRODUCTS OR SERVICES, EITHER ALONE OR IN COMBINATION WITH ANY TI PRODUCT OR SERVICE.

11.2 Documentation Support

11.2.1 Related Documentation

- [BQ2022A Evaluation Software User's Guide \(SLUU258\)](#)

11.2.2 Receiving Notification of Documentation Updates

To receive notification of documentation updates, navigate to the device product folder on [ti.com](#). Click on *Subscribe to updates* to register and receive a weekly digest of any product information that has changed. For change details, review the revision history included in any revised document.

11.3 Trademarks

SDQ™ and TI E2E™ are trademarks of Texas Instruments. All trademarks are the property of their respective owners.

11.4 Support Resources

[TI E2E™ support forums](#) are an engineer's go-to source for fast, verified answers and design help — straight from the experts. Search existing answers or ask your own question to get the quick design help you need.

Linked content is provided "AS IS" by the respective contributors. They do not constitute TI specifications and do not necessarily reflect TI's views; see TI's [Terms of Use](#).

11.5 Electrostatic Discharge Caution



This integrated circuit can be damaged by ESD. Texas Instruments recommends that all integrated circuits be handled with appropriate precautions. Failure to observe proper handling and installation procedures can cause damage.

ESD damage can range from subtle performance degradation to complete device failure. Precision integrated circuits may be more susceptible to damage because very small parametric changes could cause the device not to meet its published specifications.

11.6 Glossary

[TI Glossary](#) This glossary lists and explains terms, acronyms, and definitions.

12 Mechanical, Packaging, and Orderable Information

The following pages include mechanical, packaging, and orderable information. This information is the most current data available for the designated devices. This data is subject to change without notice and revision of this document. For browser-based versions of this data sheet, refer to the left-hand navigation.

PACKAGING INFORMATION

Orderable Device	Status (1)	Package Type	Package Drawing	Pins	Package Qty	Eco Plan (2)	Lead finish/ Ball material (6)	MSL Peak Temp (3)	Op Temp (°C)	Device Marking (4/5)	Samples
BQ2022ADBZR	ACTIVE	SOT-23	DBZ	3	3000	RoHS & Green	NIPDAU NIPDAUAG	Level-1-260C-UNLIM	-20 to 70	BYCI	Samples
BQ2022ADBZRG4	ACTIVE	SOT-23	DBZ	3	3000	RoHS & Green	NIPDAU	Level-1-260C-UNLIM	-20 to 70	BYCI	Samples
BQ2022ALPR	ACTIVE	TO-92	LP	3	2000	RoHS & Green	SN	N / A for Pkg Type	0 to 70	BYE	Samples
HPA01220DBZR	ACTIVE	SOT-23	DBZ	3	3000	RoHS & Green	NIPDAU	Level-1-260C-UNLIM	-20 to 70	BYCI	Samples

(1) The marketing status values are defined as follows:

ACTIVE: Product device recommended for new designs.

LIFEBUY: TI has announced that the device will be discontinued, and a lifetime-buy period is in effect.

NRND: Not recommended for new designs. Device is in production to support existing customers, but TI does not recommend using this part in a new design.

PREVIEW: Device has been announced but is not in production. Samples may or may not be available.

OBSOLETE: TI has discontinued the production of the device.

(2) **RoHS:** TI defines "RoHS" to mean semiconductor products that are compliant with the current EU RoHS requirements for all 10 RoHS substances, including the requirement that RoHS substance do not exceed 0.1% by weight in homogeneous materials. Where designed to be soldered at high temperatures, "RoHS" products are suitable for use in specified lead-free processes. TI may reference these types of products as "Pb-Free".

RoHS Exempt: TI defines "RoHS Exempt" to mean products that contain lead but are compliant with EU RoHS pursuant to a specific EU RoHS exemption.

Green: TI defines "Green" to mean the content of Chlorine (Cl) and Bromine (Br) based flame retardants meet JS709B low halogen requirements of <=1000ppm threshold. Antimony trioxide based flame retardants must also meet the <=1000ppm threshold requirement.

(3) MSL, Peak Temp. - The Moisture Sensitivity Level rating according to the JEDEC industry standard classifications, and peak solder temperature.

(4) There may be additional marking, which relates to the logo, the lot trace code information, or the environmental category on the device.

(5) Multiple Device Markings will be inside parentheses. Only one Device Marking contained in parentheses and separated by a "-" will appear on a device. If a line is indented then it is a continuation of the previous line and the two combined represent the entire Device Marking for that device.

(6) Lead finish/Ball material - Orderable Devices may have multiple material finish options. Finish options are separated by a vertical ruled line. Lead finish/Ball material values may wrap to two lines if the finish value exceeds the maximum column width.

Important Information and Disclaimer: The information provided on this page represents TI's knowledge and belief as of the date that it is provided. TI bases its knowledge and belief on information provided by third parties, and makes no representation or warranty as to the accuracy of such information. Efforts are underway to better integrate information from third parties. TI has taken and

continues to take reasonable steps to provide representative and accurate information but may not have conducted destructive testing or chemical analysis on incoming materials and chemicals. TI and TI suppliers consider certain information to be proprietary, and thus CAS numbers and other limited information may not be available for release.

In no event shall TI's liability arising out of such information exceed the total purchase price of the TI part(s) at issue in this document sold by TI to Customer on an annual basis.

TAPE AND REEL INFORMATION

QUADRANT ASSIGNMENTS FOR PIN 1 ORIENTATION IN TAPE

*All dimensions are nominal

Device	Package Type	Package Drawing	Pins	SPQ	Reel Diameter (mm)	Reel Width W1 (mm)	A0 (mm)	B0 (mm)	K0 (mm)	P1 (mm)	W (mm)	Pin1 Quadrant
BQ2022ADBZR	SOT-23	DBZ	3	3000	179.0	8.4	3.15	2.95	1.22	4.0	8.0	Q3
BQ2022ADBZR	SOT-23	DBZ	3	3000	180.0	8.4	3.15	2.77	1.22	4.0	8.0	Q3

TAPE AND REEL BOX DIMENSIONS

*All dimensions are nominal

Device	Package Type	Package Drawing	Pins	SPQ	Length (mm)	Width (mm)	Height (mm)
BQ2022ADBZR	SOT-23	DBZ	3	3000	200.0	183.0	25.0
BQ2022ADBZR	SOT-23	DBZ	3	3000	183.0	183.0	20.0

GENERIC PACKAGE VIEW

LP 3

TO-92 - 5.34 mm max height

TRANSISTOR OUTLINE



Images above are just a representation of the package family, actual package may vary.
Refer to the product data sheet for package details.

4040001-2/F

LP0003A



PACKAGE OUTLINE

TO-92 - 5.34 mm max height

TO-92

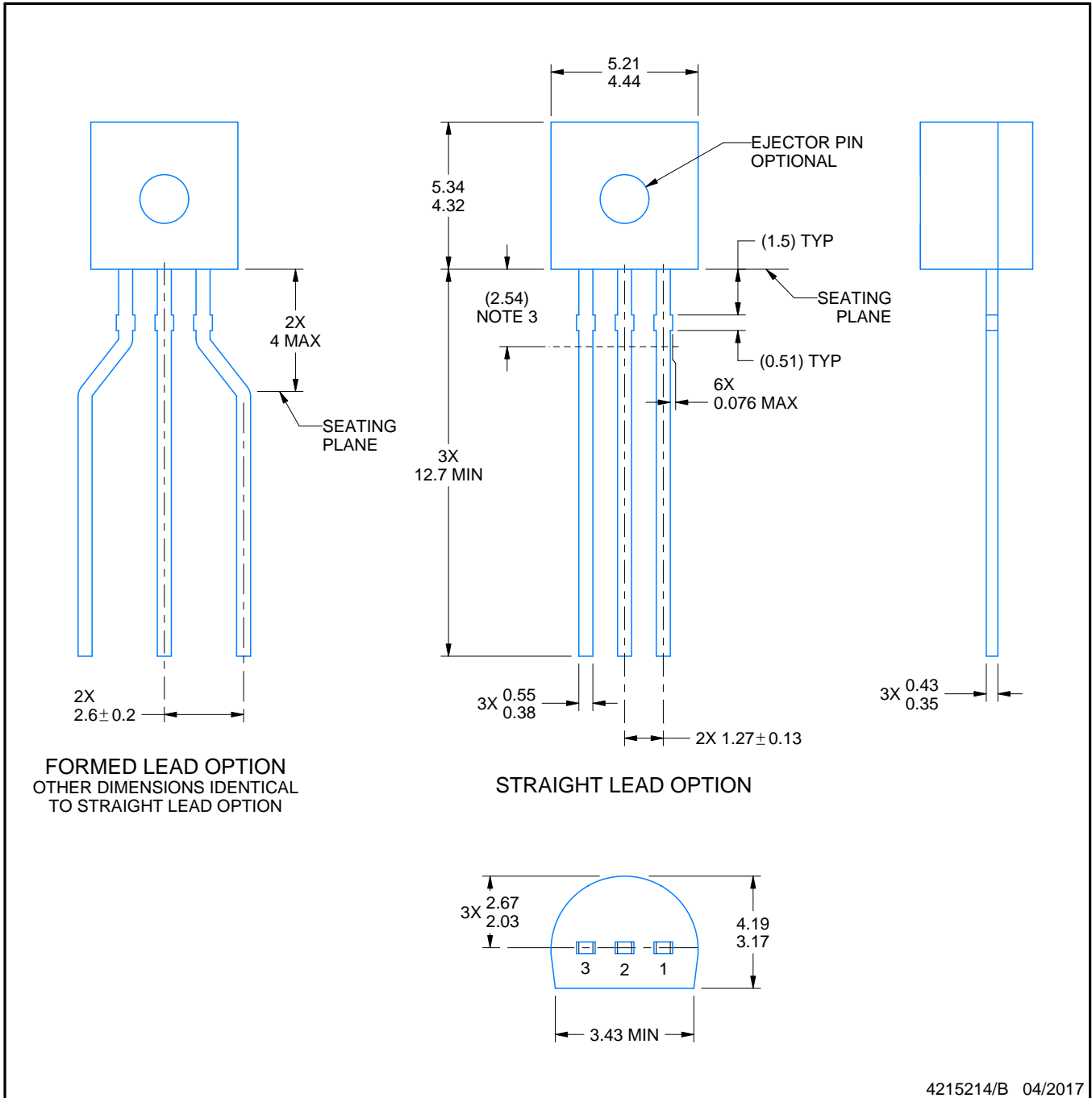

4215214/B 04/2017

NOTES:

1. All linear dimensions are in millimeters. Any dimensions in parenthesis are for reference only. Dimensioning and tolerancing per ASME Y14.5M.
2. This drawing is subject to change without notice.
3. Lead dimensions are not controlled within this area.
4. Reference JEDEC TO-226, variation AA.
5. Shipping method:
 - a. Straight lead option available in bulk pack only.
 - b. Formed lead option available in tape and reel or ammo pack.
 - c. Specific products can be offered in limited combinations of shipping medium and lead options.
 - d. Consult product folder for more information on available options.

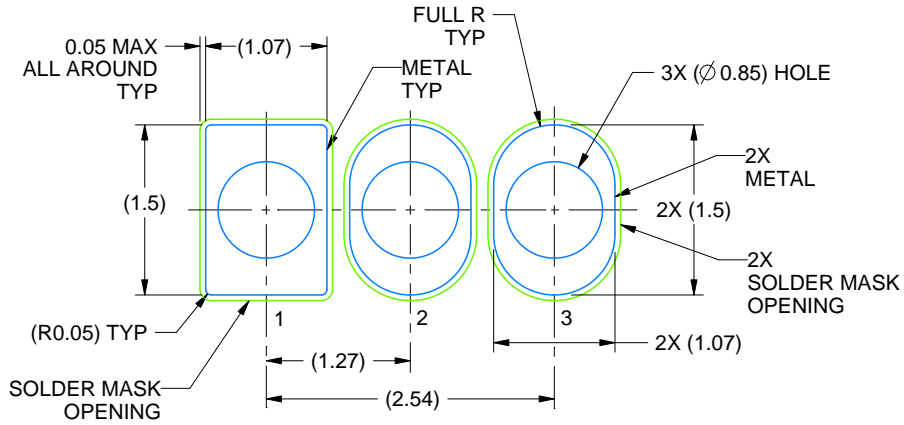

LAND PATTERN EXAMPLE
STRAIGHT LEAD OPTION
NON-SOLDER MASK DEFINED
SCALE:15X

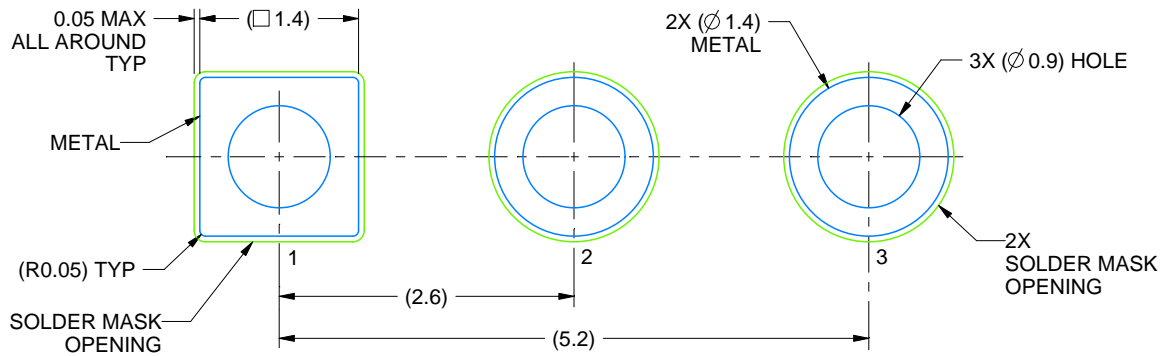

LAND PATTERN EXAMPLE
FORMED LEAD OPTION
NON-SOLDER MASK DEFINED
SCALE:15X

TAPE SPECIFICATIONS

LP0003A

TO-92 - 5.34 mm max height

TO-92

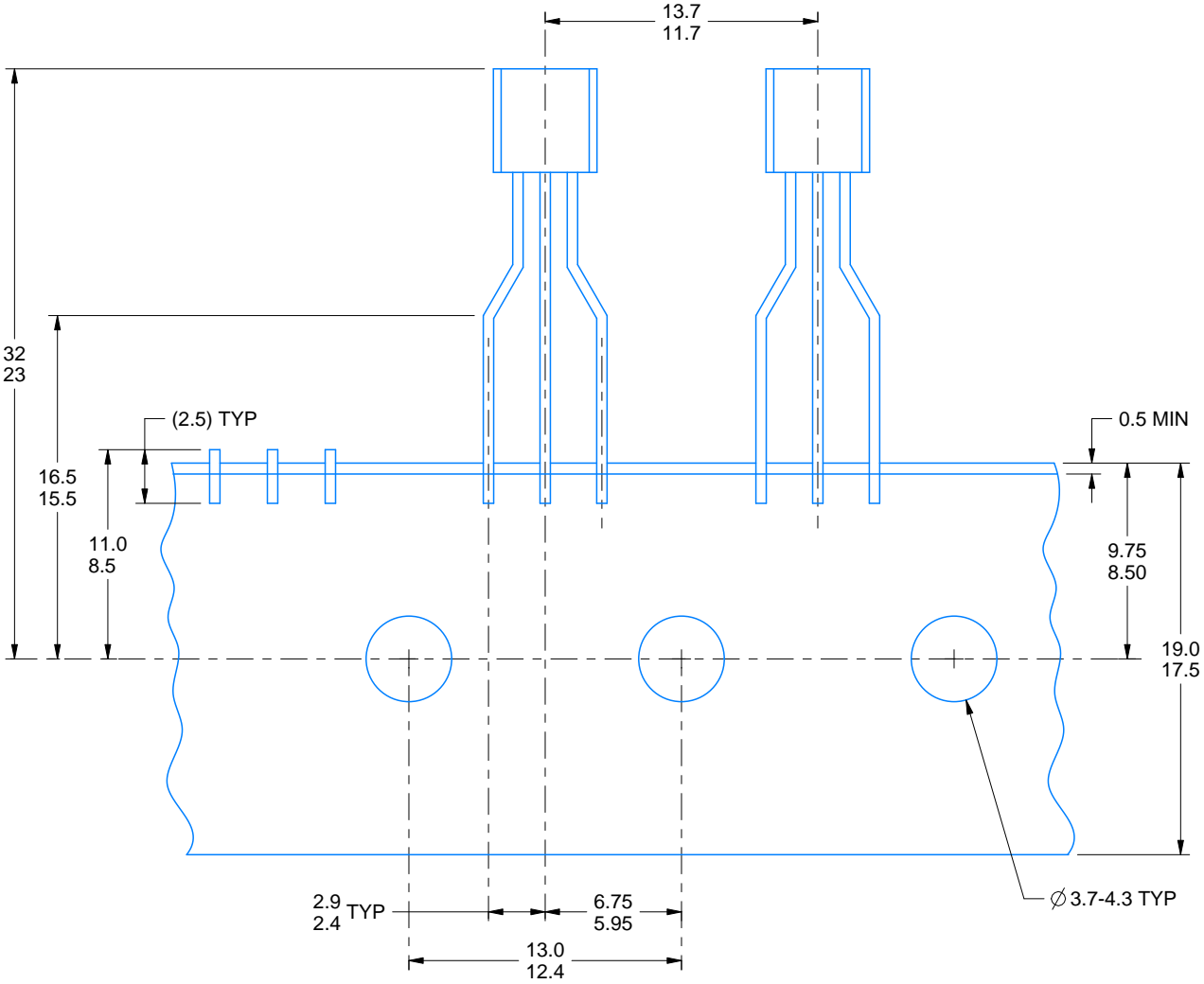

FOR FORMED LEAD OPTION PACKAGE

4215214/B 04/2017

GENERIC PACKAGE VIEW

DBZ 3

SOT-23 - 1.12 mm max height

SMALL OUTLINE TRANSISTOR

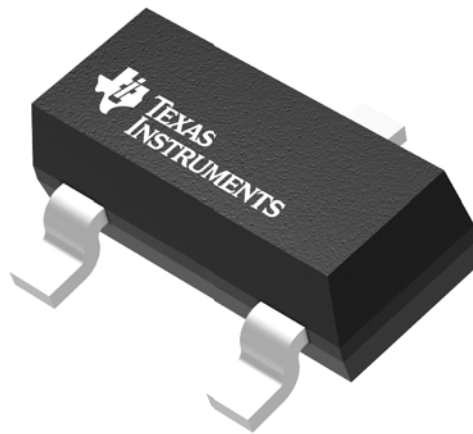

Images above are just a representation of the package family, actual package may vary.
Refer to the product data sheet for package details.

4203227/C

DBZ0003A



PACKAGE OUTLINE

SOT-23 - 1.12 mm max height

SMALL OUTLINE TRANSISTOR

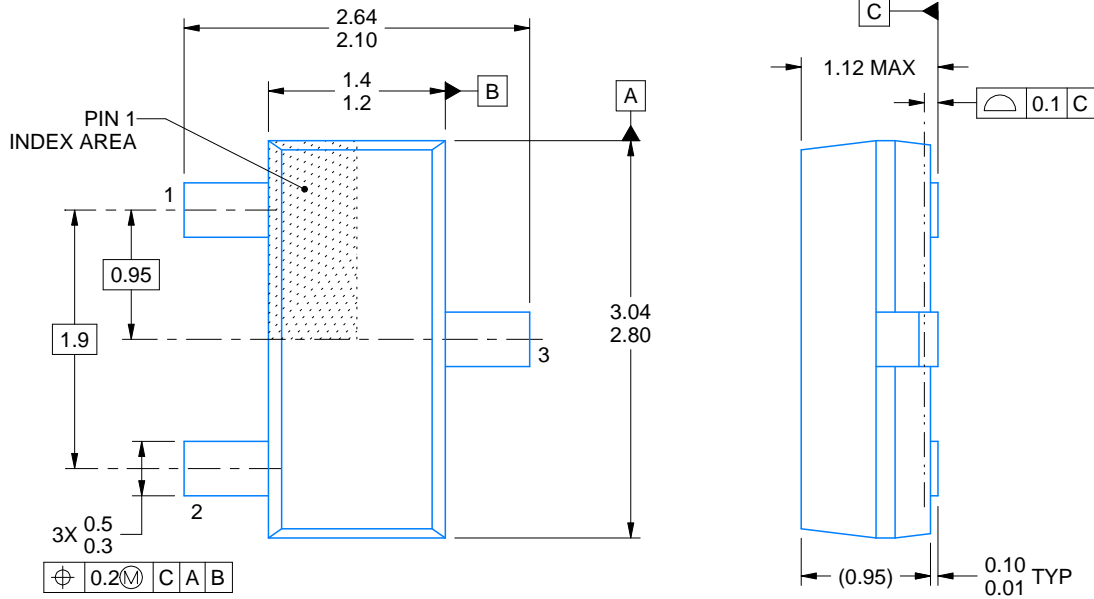

4214838/C 04/2017

NOTES:

1. All linear dimensions are in millimeters. Any dimensions in parenthesis are for reference only. Dimensioning and tolerancing per ASME Y14.5M.
2. This drawing is subject to change without notice.
3. Reference JEDEC registration TO-236, except minimum foot length.

EXAMPLE BOARD LAYOUT

DBZ0003A

SOT-23 - 1.12 mm max height

SMALL OUTLINE TRANSISTOR



LAND PATTERN EXAMPLE
SCALE:15X

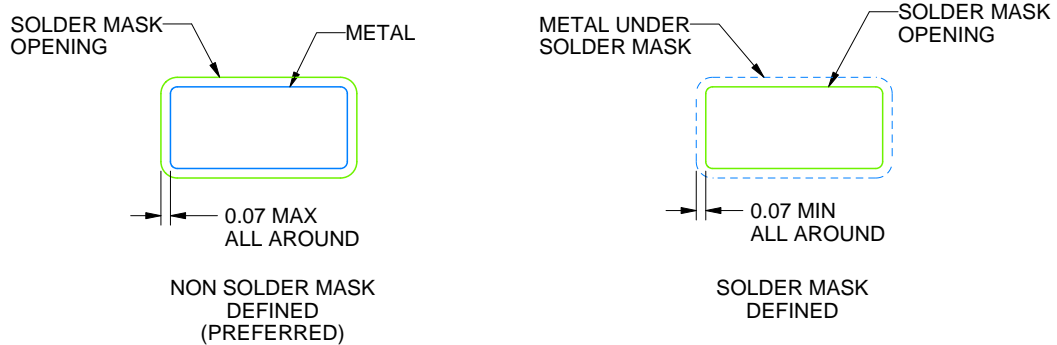

SOLDER MASK DETAILS

4214838/C 04/2017

NOTES: (continued)

- 4. Publication IPC-7351 may have alternate designs.
- 5. Solder mask tolerances between and around signal pads can vary based on board fabrication site.

EXAMPLE STENCIL DESIGN

DBZ0003A

SOT-23 - 1.12 mm max height

SMALL OUTLINE TRANSISTOR

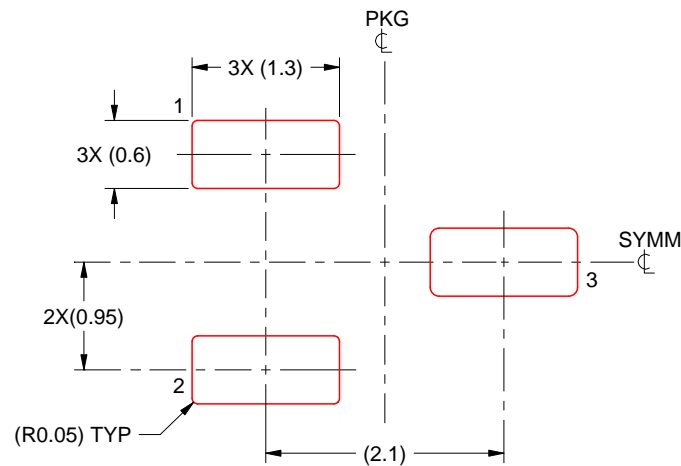

SOLDER PASTE EXAMPLE
BASED ON 0.125 THICK STENCIL
SCALE:15X

4214838/C 04/2017

NOTES: (continued)

6. Laser cutting apertures with trapezoidal walls and rounded corners may offer better paste release. IPC-7525 may have alternate design recommendations.
7. Board assembly site may have different recommendations for stencil design.

IMPORTANT NOTICE AND DISCLAIMER

TI PROVIDES TECHNICAL AND RELIABILITY DATA (INCLUDING DATA SHEETS), DESIGN RESOURCES (INCLUDING REFERENCE DESIGNS), APPLICATION OR OTHER DESIGN ADVICE, WEB TOOLS, SAFETY INFORMATION, AND OTHER RESOURCES "AS IS" AND WITH ALL FAULTS, AND DISCLAIMS ALL WARRANTIES, EXPRESS AND IMPLIED, INCLUDING WITHOUT LIMITATION ANY IMPLIED WARRANTIES OF MERCHANTABILITY, FITNESS FOR A PARTICULAR PURPOSE OR NON-INFRINGEMENT OF THIRD PARTY INTELLECTUAL PROPERTY RIGHTS.

These resources are intended for skilled developers designing with TI products. You are solely responsible for (1) selecting the appropriate TI products for your application, (2) designing, validating and testing your application, and (3) ensuring your application meets applicable standards, and any other safety, security, regulatory or other requirements.

These resources are subject to change without notice. TI grants you permission to use these resources only for development of an application that uses the TI products described in the resource. Other reproduction and display of these resources is prohibited. No license is granted to any other TI intellectual property right or to any third party intellectual property right. TI disclaims responsibility for, and you will fully indemnify TI and its representatives against, any claims, damages, costs, losses, and liabilities arising out of your use of these resources.

TI's products are provided subject to [TI's Terms of Sale](#) or other applicable terms available either on ti.com or provided in conjunction with such TI products. TI's provision of these resources does not expand or otherwise alter TI's applicable warranties or warranty disclaimers for TI products.

TI objects to and rejects any additional or different terms you may have proposed.

Mailing Address: Texas Instruments, Post Office Box 655303, Dallas, Texas 75265
Copyright © 2022, Texas Instruments Incorporated