

LMP91051 Configurable AFE for Nondispersive Infrared (NDIR) Sensing Applications

Check for Samples: [LMP91051](#)

FEATURES

- Dual Channel Input
- Programmable Gain Amplifier
- “Dark Signal” Offset Cancellation
- Supports External Filtering
- Common Mode Generator and 8 Bit DAC
- Package 14 Pin TSSOP

APPLICATIONS

- NDIR Sensing
- Demand Control Ventilation
- Building Monitoring
- CO₂ Cabin Control — Automotive
- Alcohol Detection — Automotive
- Industrial Safety and Security
- GHG & Freons Detection Platforms

KEY SPECIFICATIONS

- Programmable Gain ... 167V/V to 7986V/V
- Low Noise (0.1 to 10 Hz) ... 0.1 μ VRMS
- Gain Drift ... 20 ppm/ $^{\circ}$ C (typ)
- Phase Delay Drift ... 300 ns (typ)
- Power supply voltage range ... 2.7V to 5.5V

DESCRIPTION

The LMP91051 is a dual channel programmable integrated Sensor Analog Front End (AFE) optimized for thermopile sensors, as typically used in NDIR applications. It provides a complete signal path solution between a sensor and microcontroller that generates an output voltage proportional to the thermopile voltage. The LMP91051's programmability enables it to support multiple thermopile sensors with a single design as opposed to the multiple discrete solutions.

The LMP91051 features a programmable gain amplifier (PGA), “dark phase” offset cancellation, and an adjustable common mode generator (1.15V or 2.59V) which increases output dynamic range. The PGA offers a low gain range of 167V/V to 1335V/V plus a high gain range of 1002V/V to 7986V/V which enables the user to utilize thermopiles with different sensitivities. The PGA is highlighted by low gain drift (20 ppm/ $^{\circ}$ C), output offset drift (230 mV/ $^{\circ}$ C at G = 1002 V/V), phase delay drift (300 ns) and noise specifications (0.1 μ VRMS 0.1 to 10Hz) . The offset cancellation circuitry compensates for the “dark signal” by adding an equal and opposite offset to the input of the second stage, thus removing the original offset from the output signal. This offset cancellation circuitry allows optimized usage of the ADC full scale and relaxes ADC resolution requirements.

The LMP91051 allows extra signal filtering (high pass, low pass or band pass) through dedicated pins A0 and A1, in order to remove out of band noise. The user can program through the on board SPI interface. Available in a small form factor 14 pin TSSOP package, the LMP91051 operates from -40 to $+105^{\circ}$ C.



Please be aware that an important notice concerning availability, standard warranty, and use in critical applications of Texas Instruments semiconductor products and disclaimers thereto appears at the end of this data sheet.

All trademarks are the property of their respective owners.



These devices have limited built-in ESD protection. The leads should be shorted together or the device placed in conductive foam during storage or handling to prevent electrostatic damage to the MOS gates.

BLOCK DIAGRAM

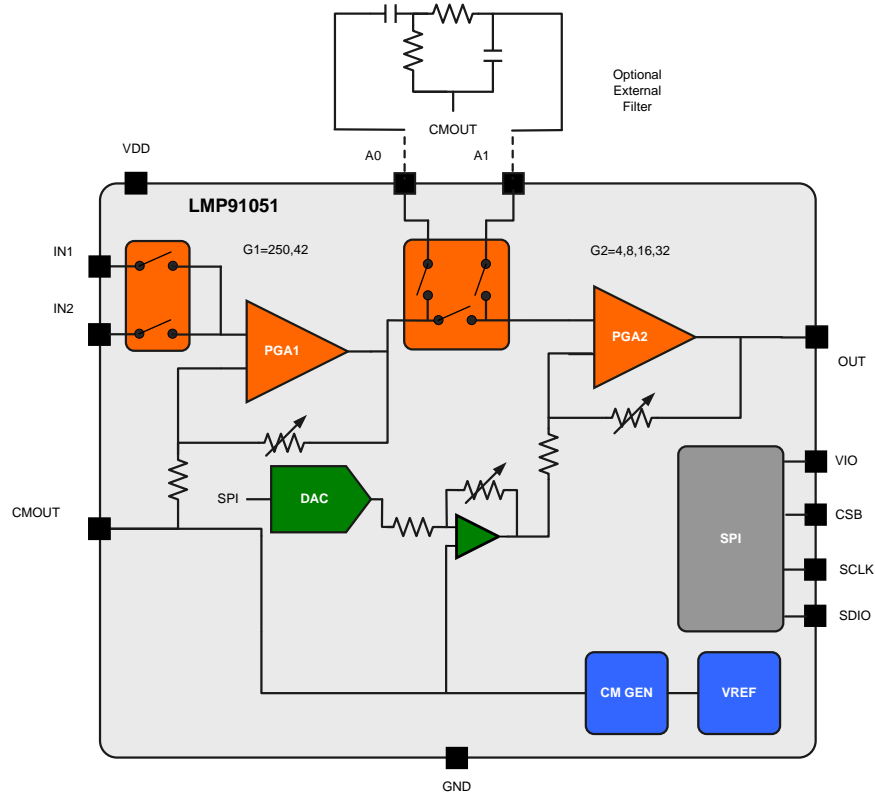

Configurable AFE for NDIR

TYPICAL APPLICATION

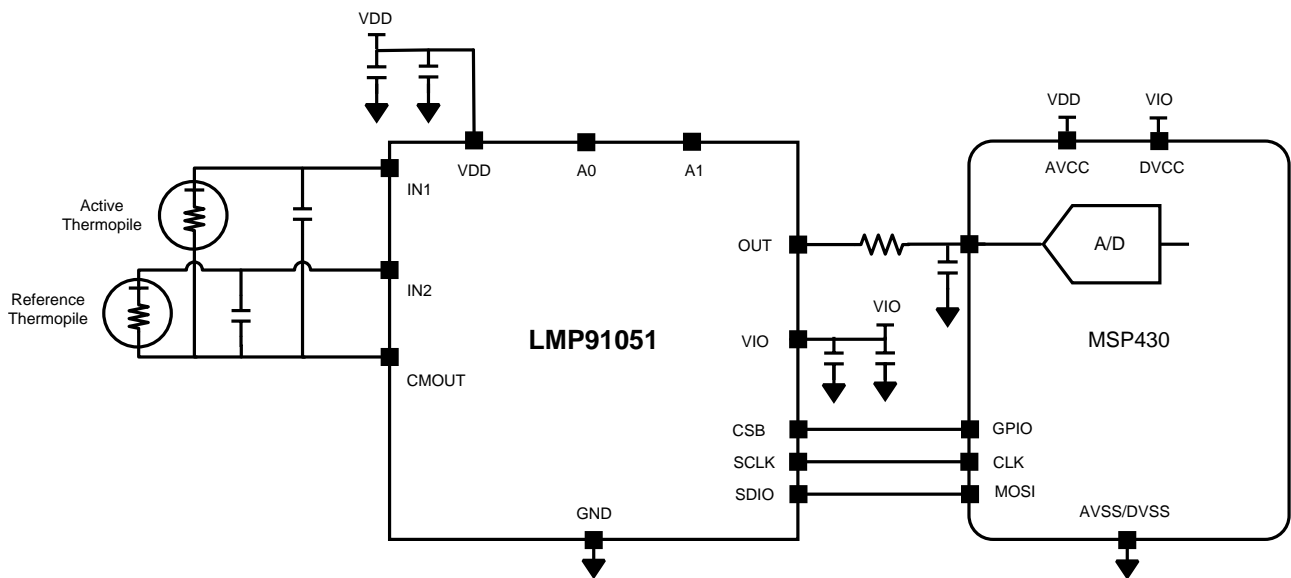

Typical NDIR Sensing Application Circuit

CONNECTION DIAGRAM

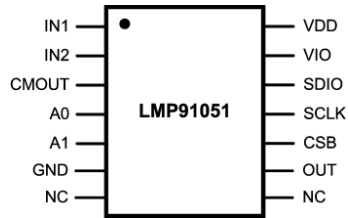

SVA-30180650

PIN DESCRIPTIONS

PIN		I/O	DESCRIPTION
NAME	NO.		
IN1	1	Analog Input	Signal Input
IN2	2	Analog Input	Signal Input
CMOUT	3	Analog Output	Common Mode Voltage Output
A0	4	Analog Output	First Stage Output
A1	5	Analog Input	Second Stage Input
GND	6	Power	Ground
NC	7	—	No Connect
NC	8	—	No Connect
OUT	9	Analog Output	Signal Output, reference to the same potential as CMOUT
CSB	10	Digital Input	Chip Select, active low
SCLK	11	Digital Input	Interface Clock
SDIO	12	Digital Input / Output	Serial Data Input / Output
VIO	13	Power	Digital Input/Output Supply
VDD	14	Power	Positive Supply

ABSOLUTE MAXIMUM RATINGS⁽¹⁾⁽²⁾

over operating free-air temperature range (unless otherwise noted)

		MIN	MAX	UNIT
ESD Tolerance ⁽³⁾	Human Body Model		1000	V
	Charged Device Model		250	
VDD	Supply Voltage	-0.3	6.0	V
VIO	Digital I/O supply	-0.3	6.0	V
	Voltage at Any Pin	-0.3	VDD + 0.3	V
	Input Current at Any Pin		5	mA
	Storage Temperature Range	65	150	°C
	Junction Temperature ⁽⁴⁾		150	°C
For soldering specifications: see product folder at www.national.com and www.national.com/ms/MS/MS-SOLDERING.pdf				

- (1) "Absolute Maximum Ratings" indicate limits beyond which damage to the device may occur, including inoperability and degradation of device reliability and/or performance. Functional operation of the device and/or non-degradation at the Absolute Maximum Ratings or other conditions beyond those indicated in the Operating Ratings is not implied. Operating Ratings indicate conditions at which the device is functional and the device should not be operated beyond such conditions.
- (2) If Military/Aerospace specified devices are required, please contact the Texas Instruments Sales Office/ Distributors for availability and specifications.
- (3) Human Body Model, applicable std. MIL-STD-883, Method 3015.7. Machine Model, applicable std. JESD22-A115-A (ESD MM std. of JEDEC) Field- Induced Charge-Device Model, applicable std. JESD22-C101-C (ESD FICDM std. of JEDEC).
- (4) The maximum power dissipation is a function of $T_{J(MAX)}$, θ_{JA} , and the ambient temperature, T_A . The maximum allowable power dissipation at any ambient temperature is $P_{DMAX} = (T_{J(MAX)} - T_A) / \theta_{JA}$. All numbers apply for packages soldered directly onto a PC board.

OPERATING CHARACTERISTICS⁽¹⁾

over operating free-air temperature range (unless otherwise noted)

PARAMETER		TEST CONDITIONS	MIN	TYP	MAX	UNIT
	Supply Voltage		2.7		5.5	V
	Junction Temperature Range ⁽²⁾		-40		105	°C
θ_{JA}	Package Thermal Resistance	Package 14 pin TSSOP			140	°C/W

- (1) "Absolute Maximum Ratings" indicate limits beyond which damage to the device may occur, including inoperability and degradation of device reliability and/or performance. Functional operation of the device and/or non-degradation at the Absolute Maximum Ratings or other conditions beyond those indicated in the Operating Ratings is not implied. Operating Ratings indicate conditions at which the device is functional and the device should not be operated beyond such conditions.
- (2) The maximum power dissipation is a function of $T_{J(MAX)}$, θ_{JA} , and the ambient temperature, T_A . The maximum allowable power dissipation at any ambient temperature is $P_{DMAX} = (T_{J(MAX)} - T_A) / \theta_{JA}$. All numbers apply for packages soldered directly onto a PC board.

ELECTRICAL CHARACTERISTICS⁽¹⁾

The following specifications apply for VDD = 3.3V, VIO = 3.3V, VCM = 1.15V, **Bold** values for $T_A = -40^\circ\text{C}$ to $+85^\circ\text{C}$ unless otherwise specified. All other limits apply to $T_A = T_J = +25^\circ\text{C}$.

PARAMETER		TEST CONDITIONS	MIN ⁽²⁾	TYP ⁽³⁾	MAX ⁽²⁾	UNIT
Power Supply						
VDD	Supply Voltage		2.7	3.3	5.5	V
VIO	Digital I/O supply		2.7	3.3	5.5	V
IDD	Supply Current	All analog block ON	3.1	3.6	4.2	mA
	Power Down Supply Current	All analog block OFF	45	75	121	μA
	Digital Supply Current			8		μA

- (1) Electrical Table values apply only for factory testing conditions at the temperature indicated. Factory testing conditions result in very limited self-heating of the device such that $T_J = T_A$. No guarantee of parametric performance is indicated in the electrical tables under conditions of internal self-heating where $T_J > T_A$. Absolute Maximum Ratings indicate junction temperature limits beyond which the device may be permanently degraded, either mechanically or electrically.
- (2) Limits are 100% production tested at 25°C. Limits over the operating temperature range are guaranteed through correlations using statistical quality control (SQC) method.
- (3) Typical values represent the most likely parametric norm as determined at the time of characterization. Actual typical values may vary over time and will also depend on the application and configuration. The typical values are not tested and are not guaranteed on shipped production material.

ELECTRICAL CHARACTERISTICS⁽¹⁾ (continued)

The following specifications apply for $V_{DD} = 3.3V$, $V_{IO} = 3.3V$, $V_{CM} = 1.15V$, **Bold** values for $T_A = -40^{\circ}C$ to $+85^{\circ}C$ unless otherwise specified. All other limits apply to $T_A = T_J = +25^{\circ}C$.

PARAMETER		TEST CONDITIONS	MIN ⁽²⁾	TYP ⁽³⁾	MAX ⁽²⁾	UNIT
Offset Cancellation (Offset DAC)						
	Resolution			256		steps
	LSB	All gains		33.8		mV
	DNL		-1		+2	LSB
	Error	Output referred offset error, all gains		±100		mV
	Offset adjust Range	Output referred, all gains	0.2		$V_{DD} - 0.2$	V
	DAC settling time			480		µs
Programmable Gain Amplifier (PGA) 1st Stage, $R_L = 10\text{ k}\Omega$, $C_L = 15\text{ pF}$						
IBIAS	Bias Current			5	200	pA
VINMAX_HGM	Max input signal High gain mode	Referenced to CMOUT voltage, it refers to the maximum voltage at the IN pin before clipping; It includes dark voltage of the thermopile and signal voltage.		±2		mV
VINMAX_LGM	Max input signal Low gain mode			±12		mV
VOS	Input Offset Voltage			-165		µV
G_HGM	Gain High gain mode			250		V/V
G_LGM	Gain Low gain mode			42		V/V
GE	Gain Error	Both HGM and LGM		2.5		%
VOUT	Output Voltage Range		0.5		$V_{DD} - 0.5$	V
PhDly	Phase Delay	1mV input step signal, HGM, Vout measured at $V_{dd}/2$		6		µs
TCPHDly	Phase Delay variation with Temperature	1mV input step signal, HGM, Vout measured at $V_{dd}/2$,		416		ns
SSBW	Small Signal Bandwidth	$V_{in} = 1\text{mV}_{pp}$, Gain = 250 V/V		18		kHz
Cin	Input Capacitance			100		pF
Programmable Gain Amplifier (PGA) 2nd Stage, $R_S = 1\text{ k}\Omega$, $C_L = 1\text{ }\mu\text{F}$						
VINMAX	Max input signal	GAIN = 4 V/V		1.65		V
VINMIN	Min input signal			0.82		V
G	Gain	Programmable in 4 steps	4		32	V/V
GE	Gain Error	Any gain		2.5		%
VOUT	Output Voltage Range		0.2		$V_{DD} - 0.2$	V
PhDly	Phase Delay	100mV input sine 35kHz signal, Gain = 8, VOUT measured at 1.65V, $R_L = 10\text{ k}\Omega$		1		µs
TCPHDly	Phase Delay variation with Temperature	250mV input step signal, Gain = 8, Vout measured at $V_{dd}/2$		84		ns
SSBW	Small Signal Bandwidth	Gain = 32 V/V		360		kHz
Cin	Input Capacitance			5		pF
CLOAD, OUT	OUT Pin Load Capacitance	Series RC		1		µF
RLOAD, OUT	OUT Pin Load Resistance	Series RC		1		kΩ

ELECTRICAL CHARACTERISTICS⁽¹⁾ (continued)

The following specifications apply for VDD = 3.3V, VIO = 3.3V, VCM = 1.15V, **Bold** values for T_A = -40°C to +85°C unless otherwise specified. All other limits apply to T_A = T_J = +25°C.

PARAMETER		TEST CONDITIONS	MIN ⁽²⁾	TYP ⁽³⁾	MAX ⁽²⁾	UNIT
Combined Amplifier Chain Specification						
en	Input-Referred Noise Density	Combination of both current and voltage noise, with a 86kΩ source impedance at 5Hz, Gain = 7986		30		nV $\sqrt{\text{Hz}}$
	Input-Referred Integrated Noise	Combination of both current and voltage noise, with a 86kΩ source impedance 0.1Hz to 10Hz, Gain = 7986		0.1	0.12 ⁽⁴⁾	μVrms
G	Gain	PGA1 GAIN = 42, PGA2 GAIN = 4		167		V/V
		PGA1 GAIN = 42, PGA2 GAIN = 8		335		
		PGA1 GAIN = 42, PGA2 GAIN = 16		669		
		PGA1 GAIN = 42, PGA2 GAIN = 3		1335		
		2 PGA1 GAIN = 250, PGA2 GAIN = 4		1002		
		PGA1 GAIN = 250, PGA2 GAIN = 8		2004		
		PGA1 GAIN = 250, PGA2 GAIN = 16		4003		
		PGA1 GAIN = 250, PGA2 GAIN = 32		7986		
GE	Gain Error	Any gain		5		%
TCCGE	Gain Temp Coefficient ⁽⁵⁾	Gain = 167 V/V, 335 V/V, 669 V/V, 1335 V/V		6		ppm/°C
		Gain = 1002 V/V, 2004 V/V, 4003 V/V, 7986V/V		20		
PSRR	Power Supply Rejection Ratio	DC, 3.0V to 3.6V supply, gain = 1002V/V	90	110		dB
PhDly	Phase Delay	1mV input step signal, Gain = 1002, Vout measured at Vdd/2		9		μs
TCPHly	Phase Delay variation with Temperature ⁽⁶⁾	1mV input step signal, Gain=1002, Vout measured at Vdd/2		300		ns
TCVOS	Output Offset Voltage Temperature Drift ⁽⁵⁾	Gain = 167 V/V		70		μV/°C
		Gain = 335 V/V		100		
		Gain = 669 V/V		160		
		Gain = 1335 V/V		290		
		Gain = 1002 V/V		230		
		Gain = 2004 V/V		420		
		Gain = 4003 V/V		800		
		Gain = 7986V/V		1550		
Common Mode Generator						
VCM	Common Mode Voltage	VDD = 3.3V		1.15		V
		VDD = 5V		2.59		
	VCM accuracy			2		%
CLOAD	CMOut Load Capacitance			10		nF

(4) Guaranteed by design and characterization. Not tested on shipped production material.

(5) TCCGE and TCVOS are calculated by taking the largest slope between -40°C and 25°C linear interpolation and 25°C and 85°C linear interpolation.

(6) TCPHly is largest change in phase delay between -40°C and 25°C measurements and 25°C and 85°C measurements.

SPI INTERFACE⁽¹⁾

The following specifications apply for VDD = 3.3V, VIO = 3.3V, VCM = 1.15V, CL = 15pF, **Bold** values for TA = –40°C to +85°C unless otherwise specified. All other limits apply to TA = TJ = +25°C.

PARAMETER		TEST CONDITIONS	MIN ⁽²⁾	TYP ⁽³⁾	MAX ⁽²⁾	UNIT
V _{IH}	Logic Input High		0.7 × VDD			V
V _{IL}	Logic Input Low				0.8	V
V _{OH}	Logic Output High		2.6			V
V _{OL}	Logic Output Low				0.4	V
I _{IH} /I _{IL}	Input Digital Leakage Current		–100 –200		100 200	nA

- (1) Electrical Table values apply only for factory testing conditions at the temperature indicated. Factory testing conditions result in very limited self-heating of the device such that TJ = TA. No guarantee of parametric performance is indicated in the electrical tables under conditions of internal self-heating where TJ > TA. Absolute Maximum Ratings indicate junction temperature limits beyond which the device may be permanently degraded, either mechanically or electrically.
- (2) Limits are 100% production tested at 25°C. Limits over the operating temperature range are guaranteed through correlations using statistical quality control (SQC) method.
- (3) Typical values represent the most likely parametric norm as determined at the time of characterization. Actual typical values may vary over time and will also depend on the application and configuration. The typical values are not tested and are not guaranteed on shipped production material.

TIMING CHARACTERISTICS⁽¹⁾

The following specifications apply for VDD = 3.3V, VIO = 3.3V, VCM = 1.15V, CL = 15pF, **Bold** values for TA = –40°C to +85°C unless otherwise specified. All other limits apply to TA = TJ = +25°C.

PARAMETER		TEST CONDITIONS	MIN ⁽²⁾	TYP ⁽³⁾	MAX ⁽²⁾	UNIT
t _{WU}	Wake up time			1		ms
f _{SCLK}	Serial Clock Frequency				10	MHz
t _{PH}	SCLK Pulse Width High		0.4/f _{SCLK}			ns
t _{PL}	SCLK Pulse Width Low		0.4/f _{SCLK}			ns
t _{CSS}	CSB Setup Time		10			ns
t _{CSH}	CSB Hold Time		10			ns
t _{SU}	SDI Setup Time prior to rise edge of SCLK		10			ns
t _{SH}	SDI Hold Time prior to rise edge of SCLK		10			ns
t _{DOD1}	SDO Disable Time after rise edge of CSB				45	ns
t _{DOD2}	SDO Disable Time after 16th rise edge of SCLK				45	ns
t _{DOE}	SDO Enable Time from the fall edge of 8th SCLK				35	ns
t _{DOA}	SDO Access Time after the fall edge of SCLK				35	ns
t _{DOH}	SDO hold time after the fall edge of SCLK		5			ns
t _{DOR}	SDO Rise time			5		ns
t _{DOF}	SDO Fall time			5		ns

- (1) Electrical Table values apply only for factory testing conditions at the temperature indicated. Factory testing conditions result in very limited self-heating of the device such that TJ = TA. No guarantee of parametric performance is indicated in the electrical tables under conditions of internal self-heating where TJ > TA. Absolute Maximum Ratings indicate junction temperature limits beyond which the device may be permanently degraded, either mechanically or electrically.
- (2) Limits are 100% production tested at 25°C. Limits over the operating temperature range are guaranteed through correlations using statistical quality control (SQC) method.
- (3) Typical values represent the most likely parametric norm as determined at the time of characterization. Actual typical values may vary over time and will also depend on the application and configuration. The typical values are not tested and are not guaranteed on shipped production material.

Timing Diagrams

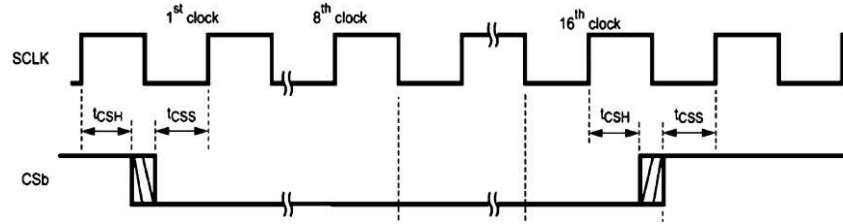

SVA-30180612

Figure 1. SPI Timing Diagram

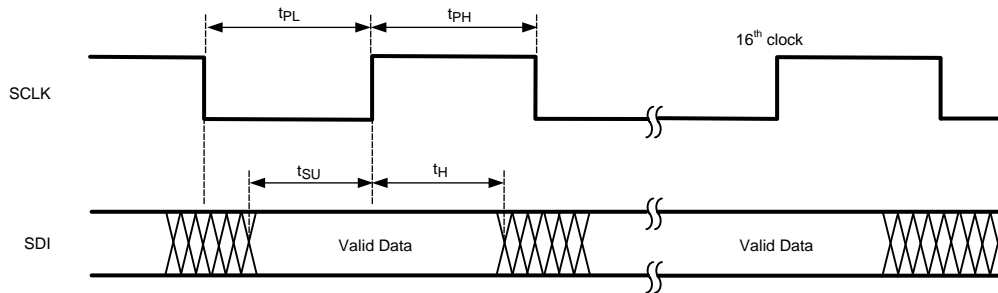

SVA-30180613

Figure 2. SPI Set-up Hold Time

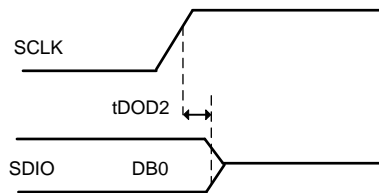

SVA-30180617

Figure 3. SDO Disable Time After 16th Rise Edge of SCLK

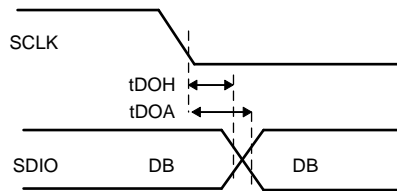

SVA-30180616

Figure 4. SDO Access Time (t_{DOA}) and SDO Hold Time (t_{DOH}) After the Fall Edge of SCLK

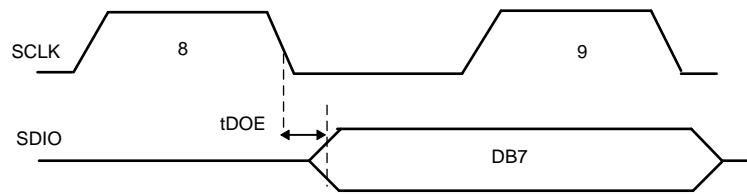

SVA-30180618

Figure 5. SDO Enable Time From the Fall Edge of 8th SCLK

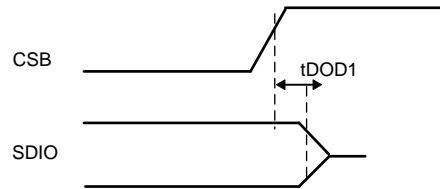

SVA-30180619

Figure 6. SDO Disable Time After Rise Edge of CSB

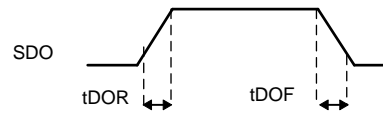

SVA-30180620

Figure 7. SDO Rise and Fall Times

TYPICAL PERFORMANCE CHARACTERISTICS

VDD = +3.3V, VCM = 1.15V, and T_A = 25°C unless otherwise noted

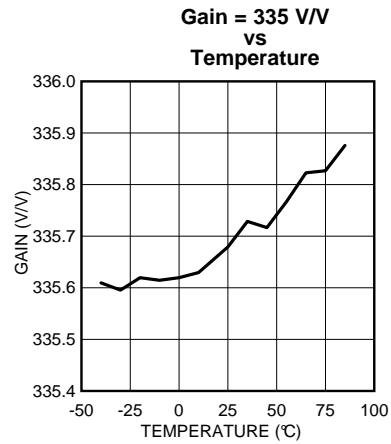
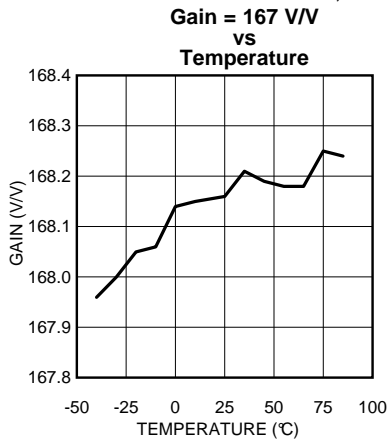

SVA-30180625

SVA-30180624

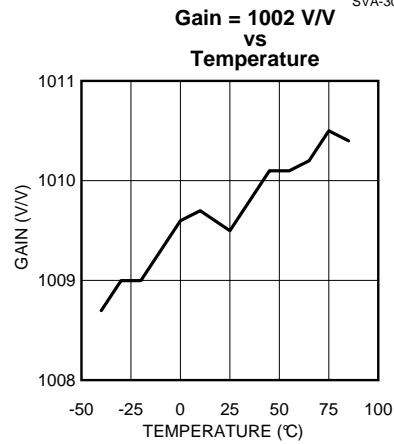
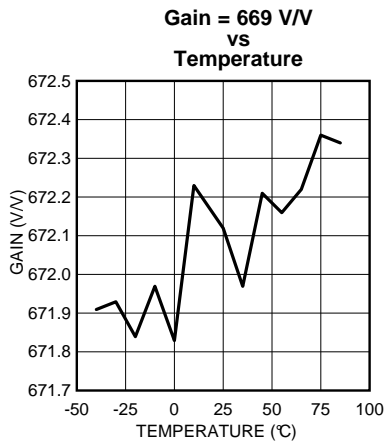

SVA-30180623

SVA-30180627

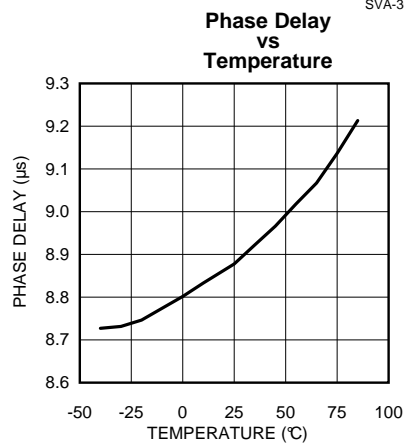
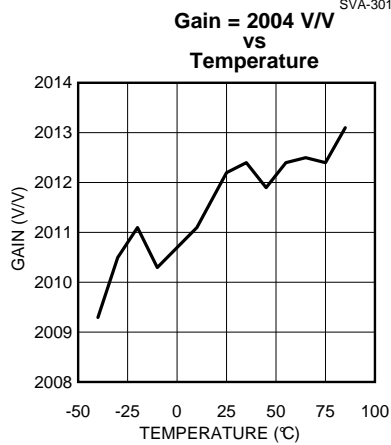

SVA-30180626

SVA-30180622

TYPICAL PERFORMANCE CHARACTERISTICS (continued)

VDD = +3.3V, VCM = 1.15V, and T_A = 25°C unless otherwise noted

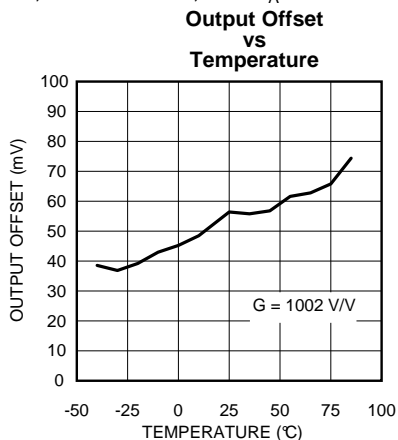

SVA-30180628

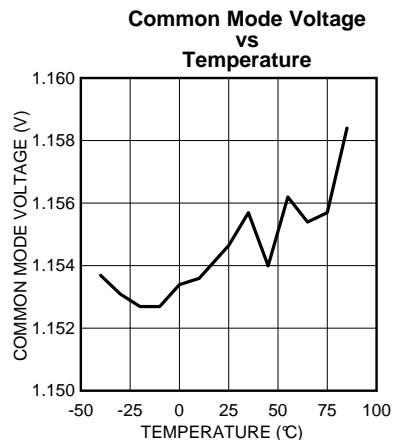

SVA-301806100

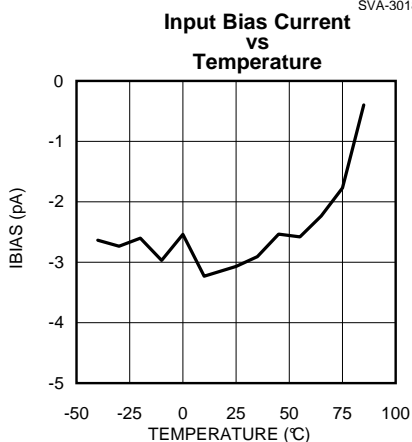

SVA-30180643

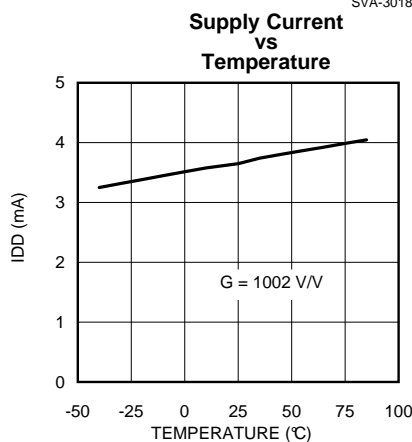

SVA-30180642

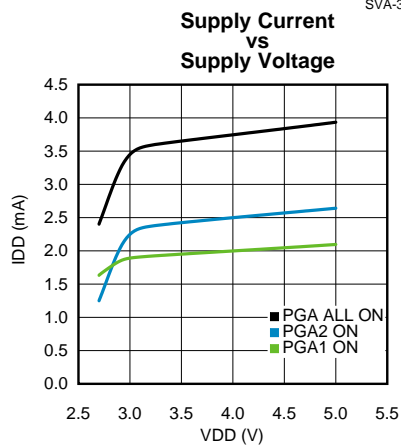

SVA-30180631

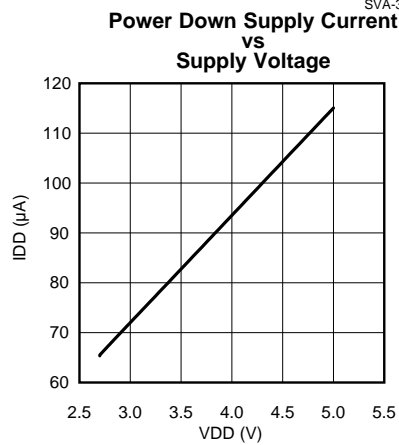

SVA-30180630

TYPICAL PERFORMANCE CHARACTERISTICS (continued)

VDD = +3.3V, VCM = 1.15V, and TA = 25°C unless otherwise noted

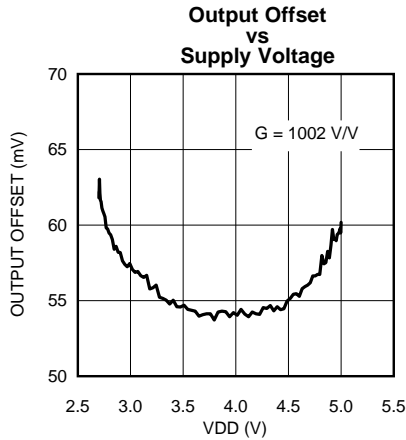

SVA-30180629

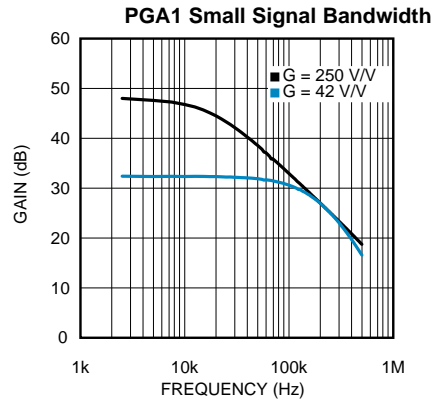

SVA-30180633

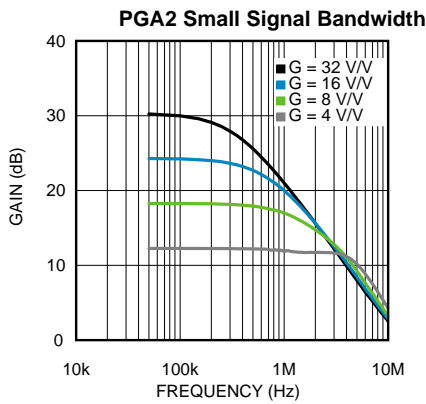

SVA-30180632

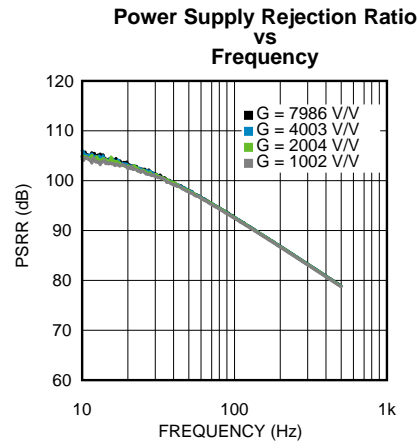

SVA-30180634

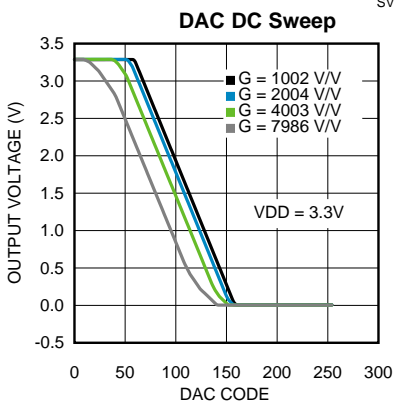

SVA-30180639

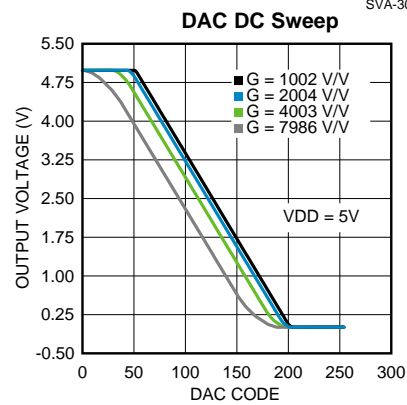

SVA-30180640

FUNCTIONAL DESCRIPTION

PROGRAMMABLE GAIN AMPLIFIER

The LMP91051 offers two programmable gain modes (low/high) with four programmable gain settings each. The purpose of the gain mode is to enable thermopiles with larger dark voltage levels. All gain settings are accessible through bits GAIN1 and GAIN2 [1:0]. The low gain mode has a range of 167 V/V to 1335 V/V while the high gain mode has a range of 1002 V/V to 7986 V/V. The PGA is referenced to the internally generated VCM. Input signal, referenced to this VCM voltage, should be within +/-2mV (see VINMAX_HGM specification) in high gain mode. In the low gain mode the first stage will provide a gain of 42 V/V instead of 250 V/V, thus allowing a larger maximum input signal up to +/-12mV (VINMAX_LGM).

Table 1. Gain Modes

BIT SYMBOL	GAIN
GAIN1	0: 250 (default) 1: 42
GAIN2 [1:0]	00: 4 (default) 01: 8 10: 16 11: 32

EXTERNAL FILTER

The LMP91051 offers two different measurement modes selectable through EXT_FILT bit. EXT_FILT bit is present in the Device configuration register and is programmable through SPI.

Table 2. Measurement Modes

BIT SYMBOL	MEASUREMENT MODE
EXT_FILT	0: The signal from the thermopile is being processed by the internal PGAs, without additional external decoupling or filtering (default).
	1: The signal from the thermopile is being processed by the first internal PGA and fed to the A0 pin. An external low pass, high pass or band pass filter can be connected through pins A0, A1.

An external filter can be applied when EXT_FILT = 1. A typical band pass filter is shown in the picture below. Resistor and capacitor can be connected to the CMOUT pin of the LMP91051 as shown. Discrete component values have been added for reference.

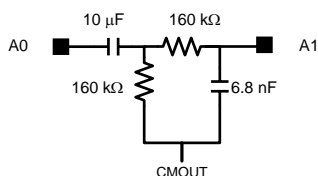

SVA-30180607

Figure 8. Typical Bandpass Filter

OFFSET ADJUST

Procedure of the offset adjust is to first measure the “dark signal”, program the DAC to adjust, and then measure in a second cycle the residual of the dark signal for further signal manipulation within the µC. The signal source is expected to have an offset component (dark signal) larger than the actual signal. During the “dark phase”, the time when no light is detected by the sensor, the µC can program LMP91051 internal DAC to compensate for a measured offset. A low output offset voltage temperature drift (TCVOS) ensures system accuracy over temperature.

COMMON MODE GENERATION

As the sensor's offset is bipolar, there is a need to supply a VCM to the sensor. This can be programmed as 1.15V or 2.59V (approximately mid rail of 3.3V or 5V supply). It is not recommended to use 2.59V VCM with 3.3V supply.

SPI INTERFACE

An SPI interface is available in order to program the device parameters like PGA gain of two stages, enabling external filter, enabling power for PGAs, offset adjust and common mode (VCM) voltage.

Interface Pins

The Serial Interface consists of SDIO (Serial Data Input / Output), SCLK (Serial Interface Clock) and CSB (Chip Select Bar). The serial interface is write-only by default. Read operations are supported after enabling the SDIO mode by programming the SDIO_MODE_EN register. This is discussed in detail later in the document.

CSB

Chip Select is a active-low signal. CSB needs to be asserted throughout a transaction. That is, CSB should not pulse between the Instruction Byte and the Data Byte of a single transaction.

Note that CSB de-assertion always terminates an on-going transaction, if it is not already complete. Likewise, CSB assertion will always bring the device into a state, ready for next transaction, regardless of the termination status of a previous transaction.

CSB may be permanently tied low for a 2-wire SPI communication protocol.

SCLK

SCLK can idle High or Low for a write transaction. However, for a READ transaction, SCLK should idle high. SCLK features a Schmitt-triggered input and although it has hysteresis, it is recommended to keep SCLK as clean as possible to prevent glitches from inadvertently spoiling the SPI frame.

Communication Protocol

Communication on the SPI normally involves Write and Read transactions. Write transaction consists of single Write Command Byte, followed by single Data byte. The following figure shows the SPI Interface Protocol for write transaction.

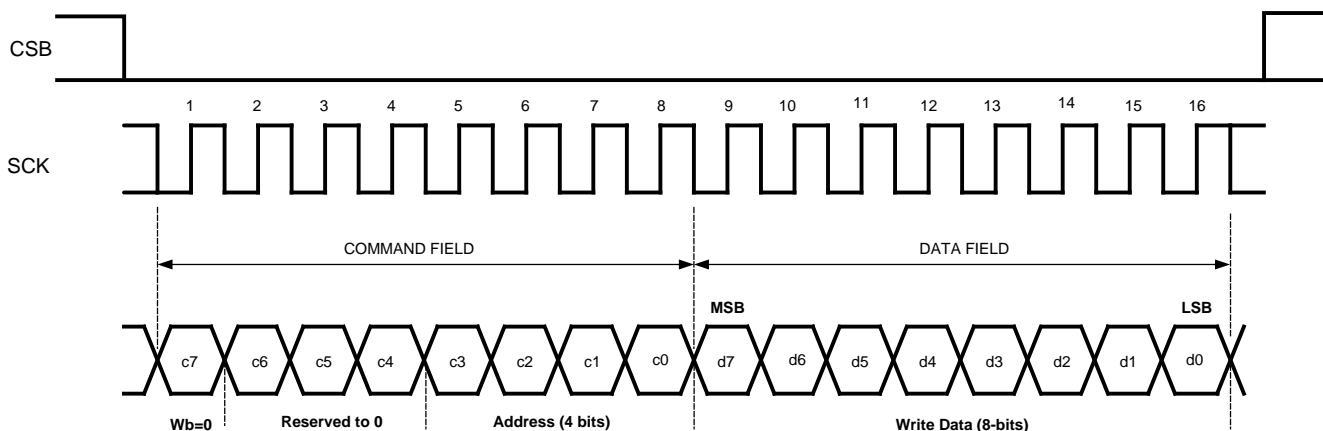

SVA-30180609

Figure 9. SPI Interface Protocol

For Read transactions, user first needs to write into a SDIO mode enable register for enabling the SPI read mode. Once the device is enabled for Reading, the data is driven out on the SDIO pin during the Data field of the Read Transaction. SDIO pin is designed as a bidirectional pin for this purpose. Figure 6 shows the Read transaction. The sequence of commands that need to be issued by the SPI Master to enable SPI read mode is illustrated in Figure 11.

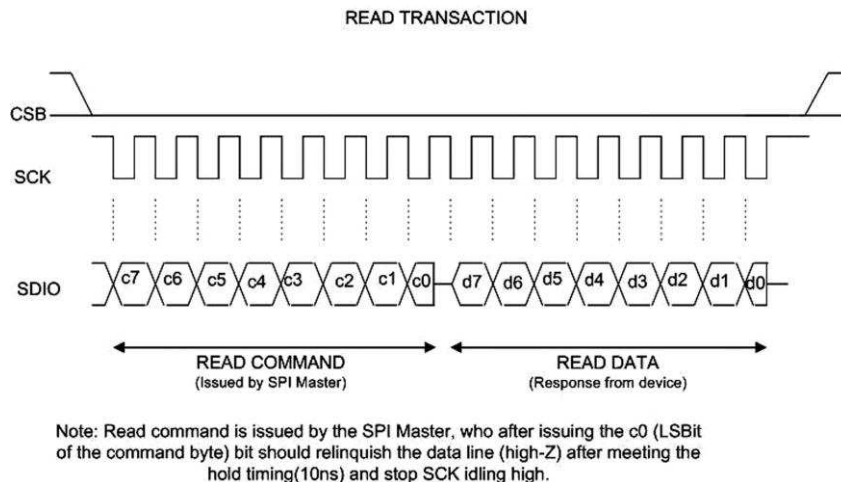

SVA-30180601

Figure 10. Read Transaction

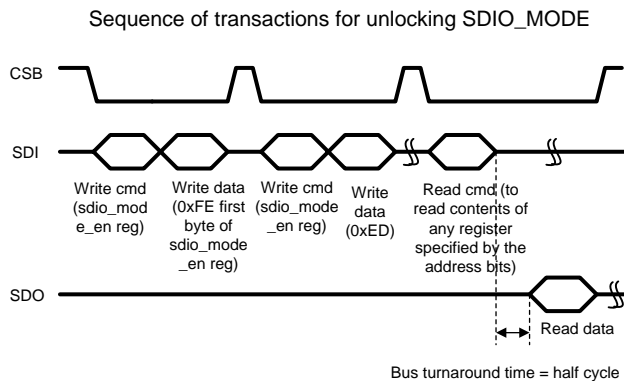

Note:

1. Once the SDIO_mode is unlocked. The user can read as many registers as long as nothing else is written to sdio_mode_en register to disturb the state of SDIO_mode
2. The separate signals SDI and SDO are given in the figure for the sake of understanding. However, only one signal SDIO exists in the design

SVA-30180615

Figure 11. Enable SDIO Mode for reading SPI registers

Registers Organization

Configuring the device is achieved using ‘Write’ of the designated registers in the device. All the registers are organized into individually addressable byte-long registers that have a unique address. The format of the Write/Read instruction is as shown below.

Table 3. Write / Read Instruction Format

BIT[7]	BIT[6:4] ⁽¹⁾	BIT[3:0]
0 : Write Instruction 1 : Read Instruction	Reserved to 0	Address

(1) Specifying any value other than zero in Bit[6:4] is prohibited.

REGISTERS

This section describes the programmable registers and the associated programming sequence, if any, for the device. The following table shows the summary listing of all the registers that are available to the user and their power-up values.

TITLE	ADDRESS (HEX) ⁽¹⁾	TYPE	POWER-UP/RESET VALUE (HEX)
Device Configuration	0x0	Read-Write (Read allowed in SDIO Mode)	0x0
DAC Configuration	0x1	Read-Write (Read allowed in SDIO Mode)	0x80
SDIO Mode Enable	0xF	Write-only	0x0

(1) Recommended values must be programmed where they are indicated in order to avoid unexpected results. Avoid writing to addresses not mentioned in the document; this could cause unexpected results.

Device Configuration – Device Configuration Register (Address 0x0)

BIT	BIT SYMBOL	DESCRIPTION
7	INP_SEL	0: IN1 (default) 1: IN2
[6:5]	EN	00: PGA1 OFF PGA2 OFF (default) 01: PGA1 OFF, PGA2 ON 10: PGA1 ON, PGA2 OFF 11: PGA1 ON, PGA2 ON
4	EXT_FILT	0: PGA1 to PGA2 direct (default) 1: PGA1 to PGA2 via external filter
3	CMN_MODE	0 : 1.15V (default) 1 : 2.59V
[2:1]	GAIN2	00: 4 (default) 01: 8 10: 16 11: 32
0	GAIN1	0: 250 (default) 1: 42

DAC Configuration – DAC Configuration Register (Address 0x1)

The output DC level will shift according to the formula $V_{out_shift} = -33.8mV * (NDAC - 128)$.

BIT	BIT SYMBOL	DESCRIPTION
[7:0]	NDAC	128 (0x80): $V_{out_shift} = -33.8mV * (128 - 128) = 0mV$ (default)

SDIO Mode – SDIO Mode Enable Register (Address 0xf) Write-only

BIT	BIT SYMBOL	DESCRIPTION
[7:0]	SDIO_MODE_EN	To enter SDIO Mode, write the successive sequence 0xFE and 0xED. Write anything other than this sequence to get out of mode.

APPLICATION INFORMATION

NDIR Gas Sensing Principle

NDIR technology, a type of IR spectroscopy, is based on the principle that gas molecules absorb IR light and absorption of a certain gas occurs at a specific wavelength. Typically, a thermopile with a built-in filter is used to detect the amount of a specific gas. For instance, since CO₂ has a strong absorbance at a wavelength of 4.26 μm, a band-pass filter is used to remove all light outside of this wavelength. Figure below shows the basic NDIR gas sensor working principle.

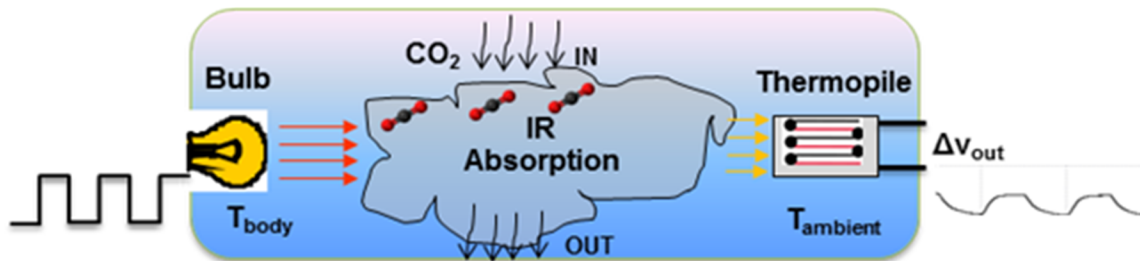

Figure 12. NDIR Gas Sensor Principle

Gas molecules will absorb radiation energy from the lamp emission. Absorption follows the Lambert-Beer law:

$$I = I_0 * e^{-kcl}$$

Where I is the transmitted IR intensity at the thermopile detector side, I₀ is the initial intensity at the IR source, k is the gas specific absorption coefficient of the target gas, c is the gas concentration, and l is the length of the absorption path from light source to thermopile detector.

The thermopile is used to detect the light intensity change. Its output voltage will follow:

$$V = n * \Delta\alpha * (T_{body} - T_{amb})$$

Where Δα is the difference of the Seebeck coefficients of the thermopile materials and n is the number of thermocouples in thermopile detector. T_{body} is the blackbody temperature that is emitting thermal radiation (i.e. the IR lamp), and T_{amb} is the temperature of the surrounding ambient.

Inside the gas chamber, the IR lamp radiation energy could be regarded as ideal black body radiation. The radiation emitted by a blackbody as a result of the temperature difference between the blackbody and ambient is known as thermal radiation. According to Stefan-Boltzmann law, thermal radiation per unit area is expressed with the following equation:

$$R_T = \sigma * (T_{body}^4 - T_{amb}^4)$$

where σ = 5.67 * 10⁻⁸ W/(m² * K⁴) is the Stefan-Boltzmann constant.

Assuming no loss in light intensity while traveling through the chamber, then R_T = I. After rearranging the equations above the equation for thermopile output voltage becomes:

$$V = n * \Delta\alpha * [I_0 * e^{-kcl}] / [\sigma * (T_{body}^2 + T_{amb}^2) * (T_{body} + T_{amb})]$$

If we examine this equation it makes sense that the thermopile output voltage will be affected by the ambient temperature and the IR lamp intensity uncertainty with a complex relationship. In order to maintain better accuracy of the system, special consideration should be taken in the design implementation. We can see that temperature compensation is an effective way to maintain system accuracy. To accomplish this thermistors are commonly integrated into the thermopile sensor and their resistance changes depending on the surrounding ambient temperature. For better measurement accuracy, having a stable constant voltage to excite the thermistor is a good choice.

Traditional Discrete Op Amp Signal Conditioning

Traditionally discrete op amps have been employed for the gain stage of NDIR systems. AC coupling is required in order to eliminate the signal chain offset. To handle a two channel system one could use a quad op amp configured in a dual channel 2 stage front end. Active filtering is built into the signal path.

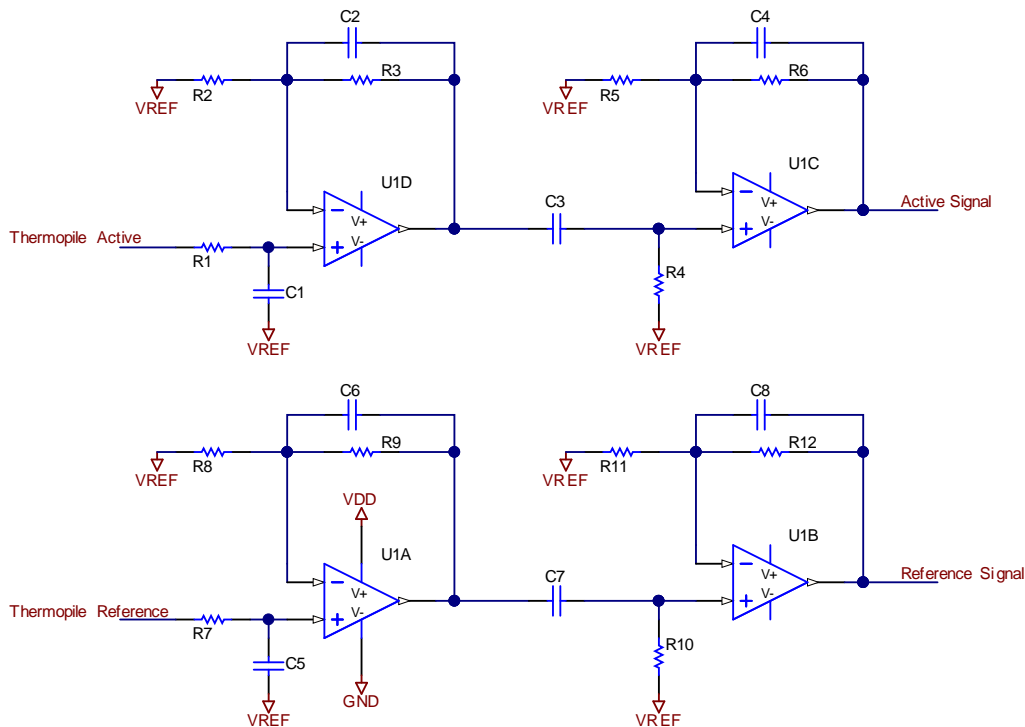

Figure 13. Discrete Op Amp Based System

LMP91051 Sensor AFE for NDIR Gas Sensing

An integrated analog front-end (AFE) can save design time and complexity by incorporating the features of a discrete op amp solution into one chip. The LMP91051 AFE contains a two channel PGA which allows easy interface to a two channel NDIR sensor. By cancelling out errors due to light source deviation optimum accuracy is obtained in a two channel system. This deviation results in long-term drift, which occurs over large periods of time. Hence, the requirement to simultaneously sample both the reference and active channel simultaneously is not required. You can use the input multiplexer (MUX) to switch between the two channels, reducing system cost and complexity, while maintaining accuracy.

The LMP91051 also has fully programmable gain and offset adjustment. This helps ensure that the small thermopile output (100's μV) is matched to the dynamic range of the sampling Analog to Digital converter (A/D) and improves system resolution. The LMP91051 also provides a common mode bias which level-shifts the thermopile sensor signal away from the negative rail, allowing for accurate sensing in the presence of sensor offset voltages.

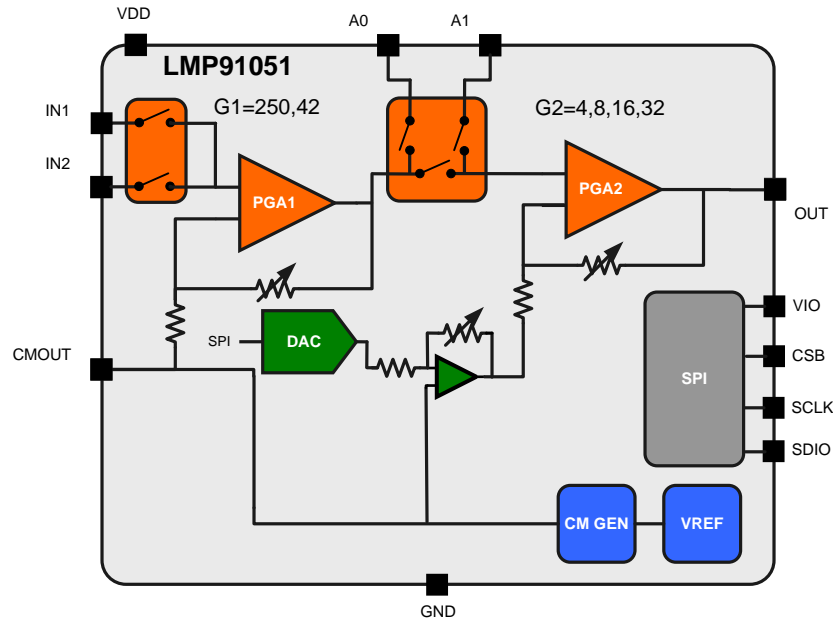

Figure 14. LMP91051 Sensor AFE for NDIR Sensing

LMP91051 Gas Detection System

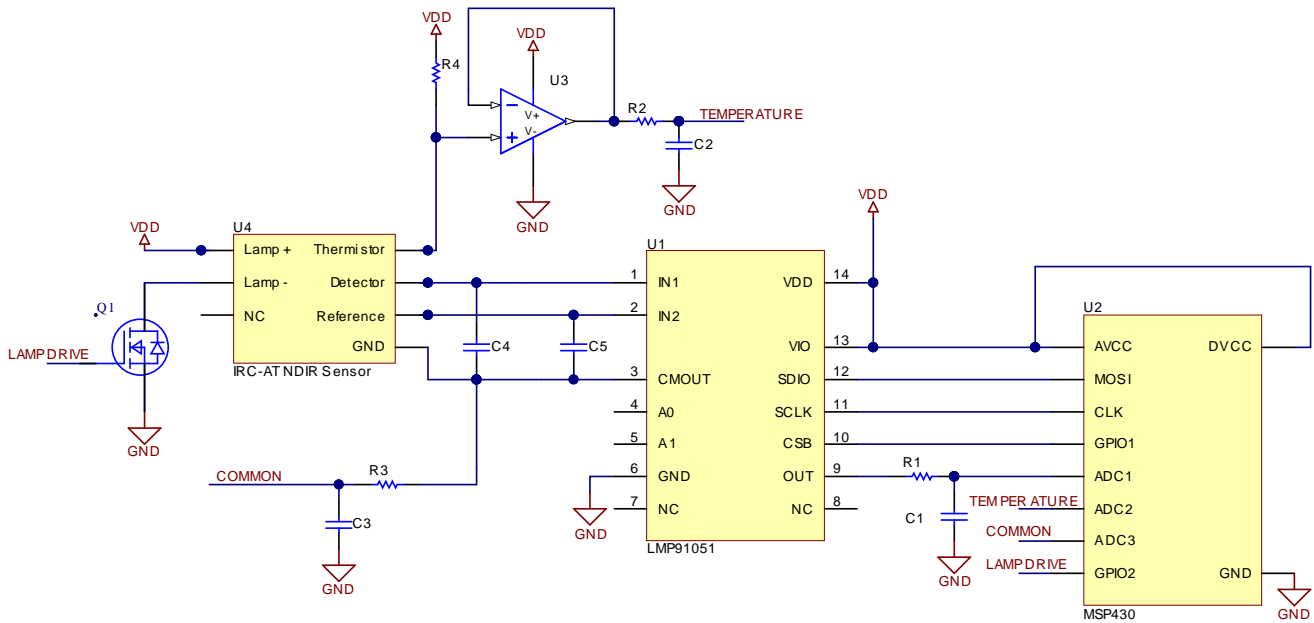

Figure 15. LMP91051 CO2 Gas Detection System

The NDIR sensor used in the proposed system is a Alphasense IRC-AT. The sensor is composed of an IR lamp, two thermopile channels, and a thermistor which is used for temperature calibration. To save power and to avoid overheating the device the lamp source is modulated typically with a 50% duty cycle with a frequency of 1 to 3Hz. The Detector (Active) and Reference channel output are connected directly to the inputs of the LMP91051. Filter capacitors are connected from each input to the common mode reference, CMOOUT, to provide low pass

filtering. LMP91051 external filtering option is disabled and pins A0 and A1 are shorted internally in the chip. No high pass filtering (AC coupling) is required because the internal offset DAC is used to cancel offset error in the signal chain. This facilitates faster measurements over the traditional AC coupled system which will be discussed further later in this application note. The NDIR sensor has an internal thermistor which is connected to a resistor bridge then buffered by an amplifier.

The MSP430 microcontroller programs the LMP91051 via SPI. The microcontroller utilizes an internal 12 bit muxed A/D to sample the LMP91051 output, buffered thermistor output, and system common mode. The entire system can be powered off of a single supply of 3V.

Gas Detection Method and Settings

In a 2 channel NDIR system the integrated IR lamp is pulsed (typical 1 to 3Hz) with a 50% duty cycle resulting in small 100's μ V RC waveforms seen on both the output of the active and reference channel. To improve measurement accuracy these signals are amplified and the peak to peak waveform voltage of both the active channel and reference channel are compared. In a DC coupled single supply system, active DC offset adjustment is required in order to ensure the output of the gain stage doesn't saturate and to remove signal chain offset errors.

In a Muxed 2 channel system toggling between channels is done at an increased rate (i.e 100Hz) in order to reliably reconstruct both channels. To ensure accurate sampling, multiple samples should be taken on each channel prior to switching channels. Preferably sampling is synced to the lamp pulses to ensure data is being capture at the expected time relative to the lamp switching and the same sample within one lamp cycle can be looked at over many lamp cycles to determine noise performance. Figure below provides a visual explanation of the proposed gas detection method.

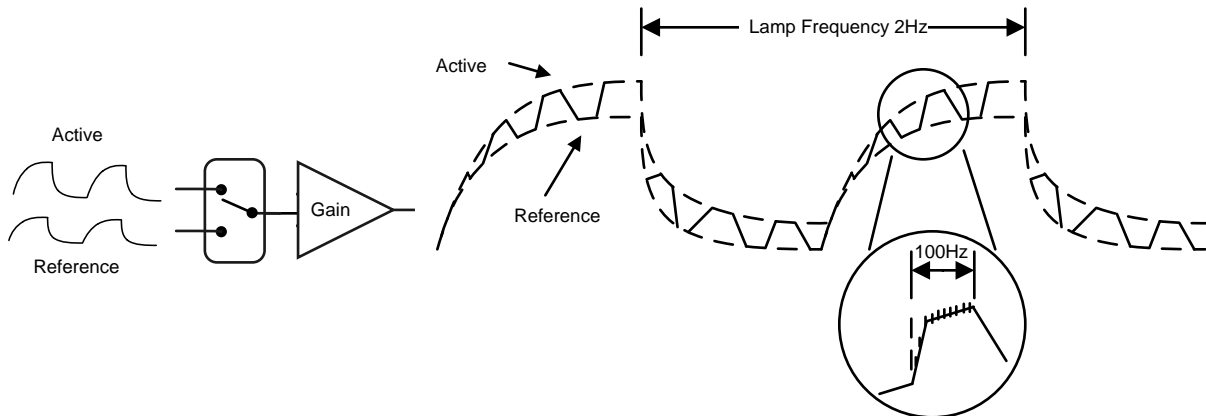

Figure 16. Example Gas Detection Method

A system was constructed with the following settings. Image below shows actual system RC waveform.

Lamp Pulse Frequency: 2 Hz

System Gain: 2000 V/V

System Offset: Apx. -700mV

Input Channel Mux Toggle Frequency: 100Hz

Number of Ch. Samples per Ch. Toggle: 10

ADC Sampling Rate: 1ksps

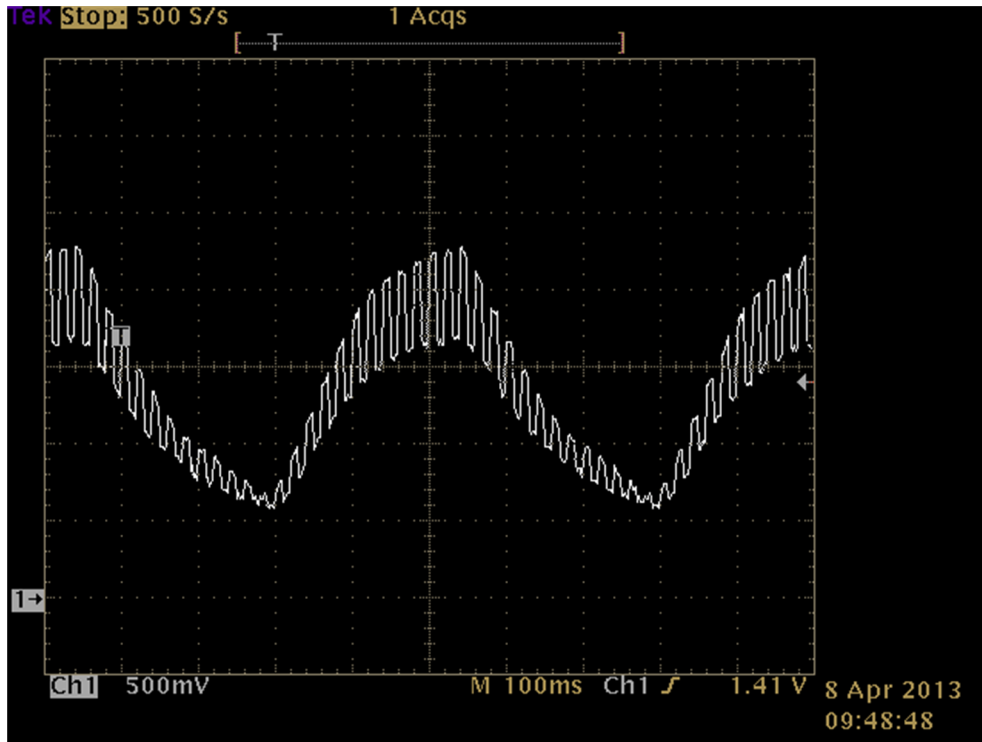



Figure 17. System Waveform

PACKAGING INFORMATION

Orderable Device	Status (1)	Package Type	Package Drawing	Pins	Package Qty	Eco Plan (2)	Lead finish/ Ball material (6)	MSL Peak Temp (3)	Op Temp (°C)	Device Marking (4/5)	Samples
LMP91051MT/NOPB	ACTIVE	TSSOP	PW	14	94	RoHS & Green	SN	Level-1-260C-UNLIM	-40 to 105	LMP910 51MT	
LMP91051MTX/NOPB	ACTIVE	TSSOP	PW	14	2500	RoHS & Green	SN	Level-1-260C-UNLIM	-40 to 105	LMP910 51MT	

(1) The marketing status values are defined as follows:

ACTIVE: Product device recommended for new designs.

LIFEBUY: TI has announced that the device will be discontinued, and a lifetime-buy period is in effect.

NRND: Not recommended for new designs. Device is in production to support existing customers, but TI does not recommend using this part in a new design.

PREVIEW: Device has been announced but is not in production. Samples may or may not be available.

OBSOLETE: TI has discontinued the production of the device.

(2) **RoHS:** TI defines "RoHS" to mean semiconductor products that are compliant with the current EU RoHS requirements for all 10 RoHS substances, including the requirement that RoHS substance do not exceed 0.1% by weight in homogeneous materials. Where designed to be soldered at high temperatures, "RoHS" products are suitable for use in specified lead-free processes. TI may reference these types of products as "Pb-Free".

RoHS Exempt: TI defines "RoHS Exempt" to mean products that contain lead but are compliant with EU RoHS pursuant to a specific EU RoHS exemption.

Green: TI defines "Green" to mean the content of Chlorine (Cl) and Bromine (Br) based flame retardants meet JS709B low halogen requirements of <=1000ppm threshold. Antimony trioxide based flame retardants must also meet the <=1000ppm threshold requirement.

(3) MSL, Peak Temp. - The Moisture Sensitivity Level rating according to the JEDEC industry standard classifications, and peak solder temperature.

(4) There may be additional marking, which relates to the logo, the lot trace code information, or the environmental category on the device.

(5) Multiple Device Markings will be inside parentheses. Only one Device Marking contained in parentheses and separated by a "~" will appear on a device. If a line is indented then it is a continuation of the previous line and the two combined represent the entire Device Marking for that device.

(6) Lead finish/Ball material - Orderable Devices may have multiple material finish options. Finish options are separated by a vertical ruled line. Lead finish/Ball material values may wrap to two lines if the finish value exceeds the maximum column width.

Important Information and Disclaimer:The information provided on this page represents TI's knowledge and belief as of the date that it is provided. TI bases its knowledge and belief on information provided by third parties, and makes no representation or warranty as to the accuracy of such information. Efforts are underway to better integrate information from third parties. TI has taken and continues to take reasonable steps to provide representative and accurate information but may not have conducted destructive testing or chemical analysis on incoming materials and chemicals. TI and TI suppliers consider certain information to be proprietary, and thus CAS numbers and other limited information may not be available for release.

In no event shall TI's liability arising out of such information exceed the total purchase price of the TI part(s) at issue in this document sold by TI to Customer on an annual basis.

TAPE AND REEL INFORMATION

QUADRANT ASSIGNMENTS FOR PIN 1 ORIENTATION IN TAPE



*All dimensions are nominal

Device	Package Type	Package Drawing	Pins	SPQ	Reel Diameter (mm)	Reel Width W1 (mm)	A0 (mm)	B0 (mm)	K0 (mm)	P1 (mm)	W (mm)	Pin1 Quadrant
LMP91051MTX/NOPB	TSSOP	PW	14	2500	330.0	12.4	6.95	5.6	1.6	8.0	12.0	Q1

TAPE AND REEL BOX DIMENSIONS

*All dimensions are nominal

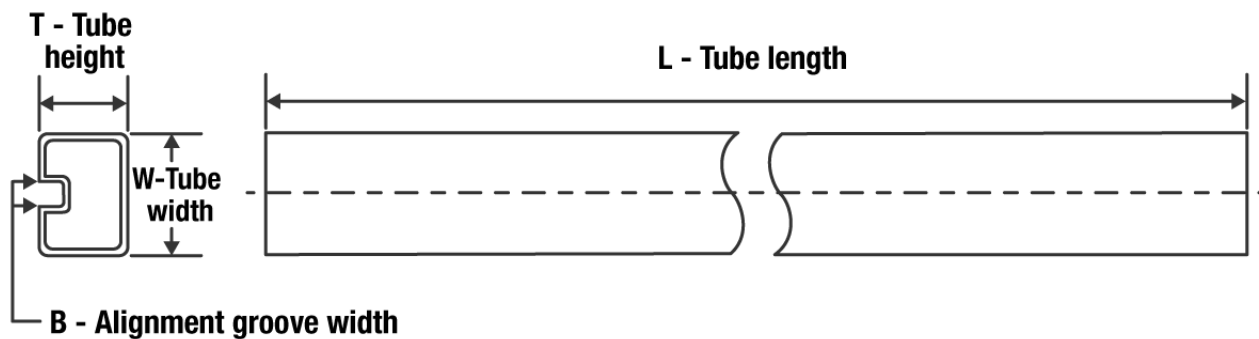
Device	Package Type	Package Drawing	Pins	SPQ	Length (mm)	Width (mm)	Height (mm)
LMP91051MTX/NOPB	TSSOP	PW	14	2500	853.0	449.0	35.0

TUBE

*All dimensions are nominal

Device	Package Name	Package Type	Pins	SPQ	L (mm)	W (mm)	T (μm)	B (mm)
LMP91051MT/NOPB	PW	TSSOP	14	94	495	8	2514.6	4.06

PW (R-PDSO-G14)

PLASTIC SMALL OUTLINE

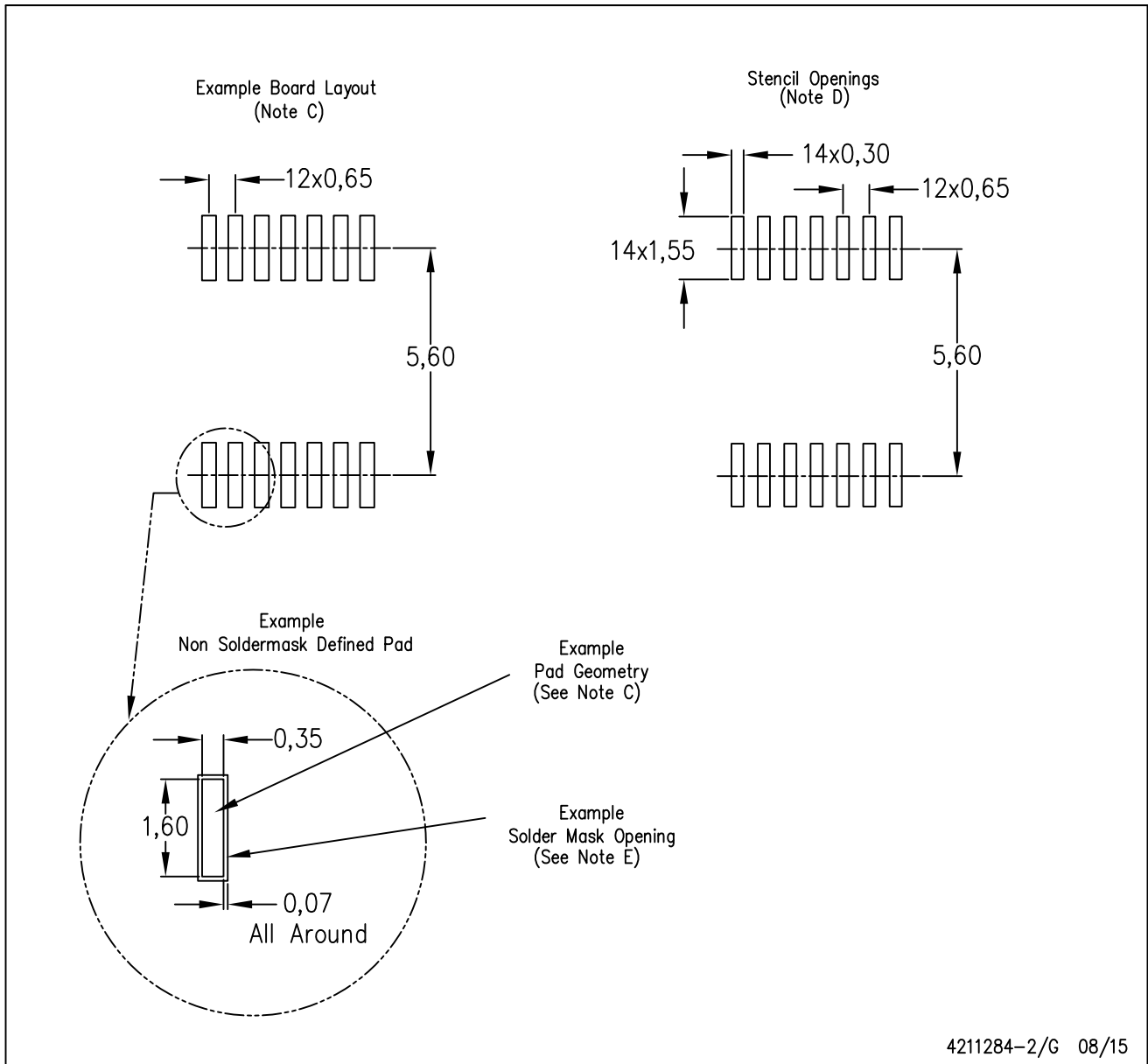

- NOTES:
- All linear dimensions are in millimeters.
 - This drawing is subject to change without notice.
 - Publication IPC-7351 is recommended for alternate designs.
 - Laser cutting apertures with trapezoidal walls and also rounding corners will offer better paste release. Customers should contact their board assembly site for stencil design recommendations. Refer to IPC-7525 for other stencil recommendations.
 - Customers should contact their board fabrication site for solder mask tolerances between and around signal pads.

IMPORTANT NOTICE AND DISCLAIMER

TI PROVIDES TECHNICAL AND RELIABILITY DATA (INCLUDING DATA SHEETS), DESIGN RESOURCES (INCLUDING REFERENCE DESIGNS), APPLICATION OR OTHER DESIGN ADVICE, WEB TOOLS, SAFETY INFORMATION, AND OTHER RESOURCES "AS IS" AND WITH ALL FAULTS, AND DISCLAIMS ALL WARRANTIES, EXPRESS AND IMPLIED, INCLUDING WITHOUT LIMITATION ANY IMPLIED WARRANTIES OF MERCHANTABILITY, FITNESS FOR A PARTICULAR PURPOSE OR NON-INFRINGEMENT OF THIRD PARTY INTELLECTUAL PROPERTY RIGHTS.

These resources are intended for skilled developers designing with TI products. You are solely responsible for (1) selecting the appropriate TI products for your application, (2) designing, validating and testing your application, and (3) ensuring your application meets applicable standards, and any other safety, security, regulatory or other requirements.

These resources are subject to change without notice. TI grants you permission to use these resources only for development of an application that uses the TI products described in the resource. Other reproduction and display of these resources is prohibited. No license is granted to any other TI intellectual property right or to any third party intellectual property right. TI disclaims responsibility for, and you will fully indemnify TI and its representatives against, any claims, damages, costs, losses, and liabilities arising out of your use of these resources.

TI's products are provided subject to [TI's Terms of Sale](#) or other applicable terms available either on ti.com or provided in conjunction with such TI products. TI's provision of these resources does not expand or otherwise alter TI's applicable warranties or warranty disclaimers for TI products.

TI objects to and rejects any additional or different terms you may have proposed.

Mailing Address: Texas Instruments, Post Office Box 655303, Dallas, Texas 75265
Copyright © 2022, Texas Instruments Incorporated