

采用 WSON 和 SOT-23 封装的 TPS61165 高亮度白光 LED 驱动器

1 特性

- 3V 至 18V 输入电压范围
- 38V 开路 LED 保护
- 200mV 基准电压，精确度 2%
- 具有 1.2MHz 开关频率的 1.2A 开关 FET
- 灵活的单线数字式和 PWM 亮度控制
- 内置软启动
- 效率高达 90%
- 2mm x 2mm x 0.8mm 6 引脚 WSON 封装（具有散热垫）和 SOT-23 封装

2 应用

- 高亮度 LED 照明
- 白色 LED 背光照明适合媒体外形显示屏
- 手持式数据终端 (EPOS)
- 恒温器显示屏
- 人机界面 (HMI)
- 视频监控摄像头
- 出口标志
- HMI 和控制面板
- 工业 PC
- IR LED 驱动器
- 冰箱
- 烤箱

3 说明

TPS61165 器件配备 40V 额定值的集成开关 FET，是一款可驱动串联 LED 的升压转换器。该升压转换器运行在

1.2MHz 固定开关频率下，开关电流限制为 1.2A，允许在普通照明条件下使用高亮度 LED。

通过外部传感器电阻器 R_{set} 来设置白色 LED 的默认电流，可将反馈电压调节至 200mV，如下面的典型应用图中所示。在运行过程中，可以使用单线数字接口（EasyScale™协议）通过 CTRL 引脚来控制 LED 电流。另外，可以将脉宽调制信号应用于 CTRL 引脚，通过该引脚占空比可以确定反馈基准电压。无论是数字模式还是 PWM 模式，TPS61165 器件都不会突发 LED 电流；因此不会在输出电容器上产生可闻噪声。为了提供最大保护，该器件具备集成开路 LED 保护功能，可禁用 TPS61165 器件以防止在开路 LED 条件下输出超过最大绝对电压额定值。

器件信息⁽¹⁾

器件型号	封装	封装尺寸（标称值）
TPS61165	SOT-23 (6)	2.90mm x 1.60mm
	WSON (6)	2.00mm x 2.00mm

(1) 如需了解所有可用封装，请参阅数据表末尾的可订购产品附录。

典型应用

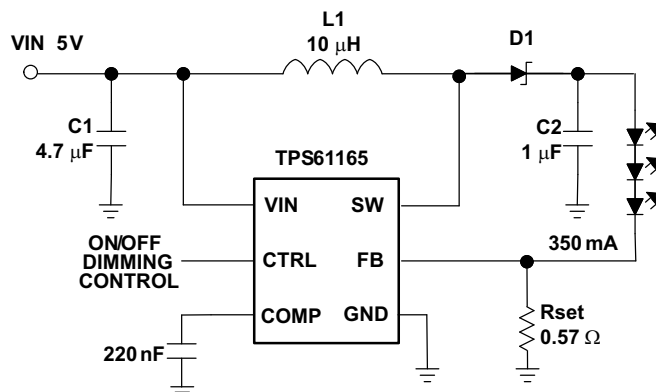

L1: TOKO #A915_Y-100M
 C1: Murata GRM188R61A475K
 C2: Murata GRM188R61E105K
 D1: ONsemi MBR0540T1
 LED: OSRAM LW-W5SM

Copyright © 2016, Texas Instruments Incorporated



目录

1	特性	1	9	Application and Implementation	10
2	应用	1	9.1	Application Information.....	10
3	说明	1	9.2	Typical Applications	12
4	修订历史记录	2	9.3	Do's and Don'ts.....	20
5	Device Options.....	3	10	Power Supply Recommendations	21
6	Pin Configuration and Functions	3	11	Layout.....	21
7	Specifications.....	4	11.1	Layout Guidelines	21
7.1	Absolute Maximum Ratings	4	11.2	Layout Example	21
7.2	Recommended Operating Conditions.....	4	11.3	Thermal Considerations	22
7.3	Thermal Information	4	12	器件和文档支持	23
7.4	Electrical Characteristics.....	5	12.1	器件支持.....	23
7.5	Timing Requirements	6	12.2	文档支持.....	23
7.6	Typical Characteristics.....	6	12.3	社区资源.....	23
8	Detailed Description	8	12.4	商标.....	23
8.1	Overview	8	12.5	静电放电警告.....	23
8.2	Functional Block Diagram	8	12.6	术语表	23
8.3	Feature Description.....	9	13	机械、封装和可订购信息.....	23
8.4	Device Functional Modes.....	9			

4 修订历史记录

Changes from Revision D (April 2016) to Revision E	Page
• 已添加 clear description to separate Easyscale Mode and PWM mode	12
• 已更改 5 khz to 6.5 khz in first paragraph after 图 10	14

Changes from Revision C (January 2015) to Revision D	Page
• 已添加 在应用 列表中增加了新的项目	1

Changes from Revision B (July 2011) to Revision C	Page
• 已添加 引脚配置和功能 部分、特性 说明 部分、器件功能模式、应用和 实施 部分、电源相关建议 部分、布局 部分、器件和文档支持 部分以及机械、封装和可订购信息 部分	1

Changes from Revision A (May 2010) to Revision B	Page
• Replaced the Dissipations Ratings Table with the Thermal Information Table.....	4
• Changed 图 10	14
• Changed Additional Application Circuits and added text "For Assistance..."	18

Changes from Original (November 2007) to Revision A	Page
• 已添加 在标题、最后一个 特性 项和“说明”的最后一段中增加了“和 SOT-23 封装”的字样	1
• Added 6-pin SOT-23 pinout to the Device Information section	3
• Added the DBV package to the Ordering Information table	3
• Changed the Dissipation Rating Table to include the DBV package	4
• 已更改 two values in the last paragraph of the MAXIMUM OUTPUT CURRENT section - From: 65 mA To: 110 mA in typical condition, and From: 85 mA To: 150 mA in typical condition.....	10

5 Device Options

T _A	OPEN LED PROTECTION	PACKAGE ⁽¹⁾	PACKAGE MARKING
-40°C to 85°C	38 V (typical)	TPS61165DRV	CCQ
		TPS61165DBV	DAK

(1) The DRV package is available in tape and reel. Add R suffix (TPS61165DRVR) to order quantities of 3000 parts per reel or add T suffix (TPS61165DRVT) to order 250 parts per reel.

6 Pin Configuration and Functions

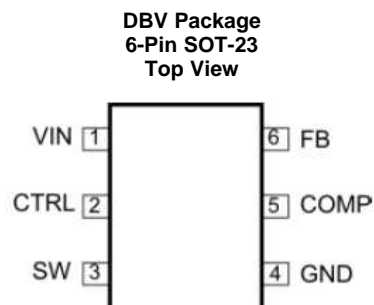
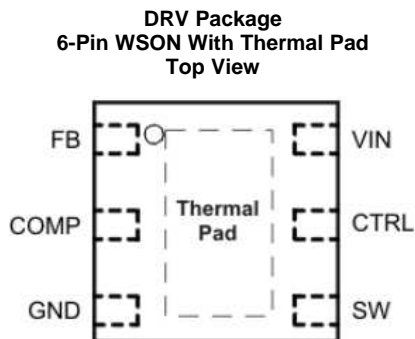

Pin Functions

NAME	PIN		TYPE	DESCRIPTION
	WSON NO.	SOT-23 NO.		
CTRL	5	2	I	Control pin of the boost converter. It is a multifunctional pin which can be used for enable control, PWM and digital dimming.
COMP	2	5	O	Output of the transconductance error amplifier. Connect an external capacitor to this pin to compensate the converter.
FB	1	6	I	Feedback pin for current. Connect the sense resistor from FB to GND.
GND	3	4	O	Ground
SW	4	3	I	This is the switching node of the device. Connect the switched side of the inductor to SW. This pin is also used to sense the output voltage for open LED protection.
VIN	6	1	I	The input supply pin for the IC. Connect VIN to a supply voltage between 3 V and 18 V.
Thermal Pad	—	—	—	The thermal pad must be soldered to the analog ground plane. If possible, use thermal via to connect to ground plane for ideal power dissipation.

7 Specifications

7.1 Absolute Maximum Ratings

over operating free-air temperature range (unless otherwise noted)⁽¹⁾

		MIN	MAX	UNIT
V _{IN}	Supply voltages on VIN ⁽²⁾	-0.3	20	V
	Voltages on CTRL ⁽²⁾	-0.3	20	V
	Voltage on FB and COMP ⁽²⁾	-0.3	3	V
	Voltage on SW ⁽²⁾	-0.3	40	V
P _D	Continuous power dissipation	See Thermal Information		
T _J	Operating junction temperature	-40	150	°C
T _{stg}	Storage temperature	-65	150	°C

- (1) Stresses beyond those listed under *Absolute Maximum Ratings* may cause permanent damage to the device. These are stress ratings only, and functional operation of the device at these or any other conditions beyond those indicated under *Recommended Operating Conditions* is not implied. Exposure to absolute-maximum-rated conditions for extended periods may affect device reliability.
- (2) All voltage values are with respect to network ground pin.

7.2 Recommended Operating Conditions

		MIN	TYP	MAX	UNIT
V _I	Input voltage range, VIN	3		18	V
V _O	Output voltage range	V _{IN}		38	V
L	Inductor ⁽¹⁾	10		22	μH
f _{dim}	PWM dimming frequency	5		100	kHz
C _{IN}	Input capacitor	1			μF
C _O	Output capacitor	1		10	μF
T _A	Operating ambient temperature	-40		85	°C
T _J	Operating junction temperature	-40		125	°C

- (1) These values are recommended values that have been successfully tested in several applications. Other values may be acceptable in other applications but should be fully tested by the user.

7.3 Thermal Information

THERMAL METRIC ⁽¹⁾⁽²⁾		TPS61165		UNIT
		DRV (WSON)	DBV (SOT-23)	
		6 PINS	6 PINS	
R _{θJA}	Junction-to-ambient thermal resistance	80.7	210.1	°C/W
R _{θJC(top)}	Junction-to-case(top) thermal resistance	55.4	46.8	°C/W
R _{θJB}	Junction-to-board thermal resistance	140.2	56.7	°C/W
ψ _{JT}	Junction-to-top characterization parameter	0.3	0.5	°C/W
ψ _{JB}	Junction-to-board characterization parameter	36.5	50.2	°C/W
R _{θJC(bottom)}	Junction-to-case(bottom) thermal resistance	0.9	—	°C/W

- (1) 有关传统和新热指标的更多信息，请参见应用报告《半导体和 IC 封装热指标》（文献编号：SPRA953）。
- (2) 有关该器件的基于 PCB 覆铜区的热评估信息，请参阅 TI PCB 热应力计算。

7.4 Electrical Characteristics

 $V_{IN} = 3.6\text{ V}$, $CTRL = V_{IN}$, $T_A = -40^\circ\text{C}$ to $+85^\circ\text{C}$, typical values are at $T_A = 25^\circ\text{C}$ (unless otherwise noted)

PARAMETER		TEST CONDITIONS	MIN	TYP	MAX	UNIT
SUPPLY CURRENT						
V_I	Input voltage range, V_{IN}		3		18	V
I_Q	Operating quiescent current into VIN	Device PWM switching no load			2.3	mA
I_{SD}	Shutdown current	$CTRL=GND$, $V_{IN} = 4.2\text{ V}$			1	μA
UVLO	Undervoltage lockout threshold	V_{IN} falling		2.2	2.5	V
V_{hys}	Undervoltage lockout hysteresis			70		mV
ENABLE AND REFERENCE CONTROL						
$V_{(CTRLh)}$	CTRL logic high voltage	$V_{IN} = 3\text{ V}$ to 18 V	1.2			V
$V_{(CTRLl)}$	CTRL logic low voltage	$V_{IN} = 3\text{ V}$ to 18 V			0.4	V
$R_{(CTRL)}$	CTRL pull down resistor		400	800	1600	k Ω
t_{off}	CTRL pulse width to shutdown	CTRL high to low	2.5			ms
t_{es_det}	Easy Scale detection time ⁽¹⁾	CTRL pin low	260			μs
t_{es_delay}	Easy Scale detection delay		100			μs
t_{es_win}	Easy Scale detection window time	Measured from CTRL high	1			ms
VOLTAGE AND CURRENT CONTROL						
V_{REF}	Voltage feedback regulation voltage		196	200	204	mV
$V_{(REF_PWM)}$	Voltage feedback regulation voltage under brightness control	$V_{FB} = 50\text{ mV}$	47	50	53	mV
		$V_{FB} = 20\text{ mV}$	17	20	23	
I_{FB}	Voltage feedback input bias current	$V_{FB} = 200\text{ mV}$			2	μA
f_S	Oscillator frequency		1.0	1.2	1.5	MHz
D_{max}	Maximum duty cycle	$V_{FB} = 100\text{ mV}$	90%	93%		
t_{min_on}	Minimum on pulse width			40		ns
I_{sink}	Comp pin sink current			100		μA
I_{source}	Comp pin source current			100		μA
G_{ea}	Error amplifier transconductance		240	320	400	umho
R_{ea}	Error amplifier output resistance			6		M Ω
f_{ea}	Error amplifier crossover frequency	5 pF connected to COMP		500		kHz
POWER SWITCH						
$R_{DS(ON)}$	N-channel MOSFET on-resistance	$V_{IN} = 3.6\text{ V}$		0.3	0.6	Ω
		$V_{IN} = 3.0\text{ V}$			0.7	
I_{LN_NFET}	N-channel leakage current	$V_{SW} = 35\text{ V}$, $T_A = 25^\circ\text{C}$			1	μA
OC and OLP						
I_{LIM}	N-Channel MOSFET current limit	$D = D_{max}$	0.96	1.2	1.44	A
I_{LIM_Start}	Start up current limit	$D = D_{max}$		0.7		A
t_{Half_LIM}	Time step for half current limit			5		ms
V_{ovp}	Open LED protection threshold	Measured on the SW pin	37	38	39	V
$V_{(FB_OVP)}$	Open LED protection threshold on FB	Measured on the FB pin, percentage of V_{ref} , $V_{ref} = 200\text{ mV}$ and 20 mV		50%		
t_{REF}	V_{REF} filter time constant			180		μs
t_{step}	V_{REF} ramp up time	Each step, Measured as number of cycles of the 1.2-MHz clock		213		μs
THERMAL SHUTDOWN						
$T_{shutdown}$	Thermal shutdown threshold			160		$^\circ\text{C}$
$T_{hysteresis}$	Thermal shutdown threshold hysteresis			15		$^\circ\text{C}$

(1) To select EasyScale mode, the CTRL pin has to be low for more than t_{es_det} during t_{es_win} .

7.5 Timing Requirements

			MIN	NOM	MAX	UNIT
EasyScale TIMING						
t_{start}	Start time of program stream		2			μs
t_{EOS}	End time of program stream		2		360	μs
t_{H_LB}	High time low bit	Logic 0	2		180	μs
t_{L_LB}	Low time low bit	Logic 0	$2 \times t_{H_LB}$		360	μs
t_{H_HB}	High time high bit	Logic 1	$2 \times t_{L_HB}$		360	μs
t_{L_HB}	Low time high bit	Logic 1	2		180	μs
V_{ACKNL}	Acknowledge output voltage low	Open drain, $R_{pullup} = 15 \text{ k}\Omega$ to V_{IN}			0.4	V
$t_{valACKN}$	Acknowledge valid time	See ⁽¹⁾			2	μs
t_{ACKN}	Duration of acknowledge condition	See ⁽¹⁾			512	μs

(1) Acknowledge condition active 0, this condition is only applied in case the RFA bit is set. Open-drain output, line must be pulled high by the host with resistor load.

7.6 Typical Characteristics

表 1. Table of Graphs

		FIGURE
Efficiency	3 LEDs ($V_{OUT} = 12 \text{ V}$); $V_{IN} = 3, 5, 8.5 \text{ V}$; $L = 10 \mu\text{H}$	图 1
Efficiency	6 LEDs ($V_{OUT} = 24 \text{ V}$); $V_{IN} = 5, 8.5, 12 \text{ V}$; $L = 10 \mu\text{H}$	图 2
Current limit	$T_A = 25^\circ\text{C}$	图 3
Current limit		图 4
Easyscale step		图 13
PWM dimming linearity	$V_{IN} = 3.6 \text{ V}$; PWM Freq = 10 kHz and 32 kHz	图 14
Output ripple at PWM dimming	3 LEDs; $V_{IN} = 5 \text{ V}$; $I_{LOAD} = 350 \text{ mA}$; PWM = 32 kHz	图 15
Switching waveform	3 LEDs; $V_{IN} = 5 \text{ V}$; $I_{LOAD} = 350 \text{ mA}$; $L = 10 \mu\text{H}$	图 5
Start-up	3 LEDs; $V_{IN} = 5 \text{ V}$; $I_{LOAD} = 350 \text{ mA}$; $L = 10 \mu\text{H}$	图 6
Open LED protection	8 LEDs; $V_{IN} = 3.6 \text{ V}$; $I_{LOAD} = 20 \text{ mA}$	图 7



图 1. Efficiency vs Output Current



图 2. Efficiency vs Output Current

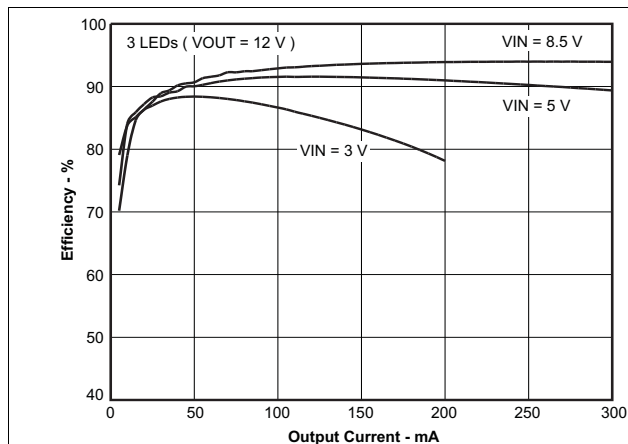

图 3. Switch Current Limit vs Duty Cycle

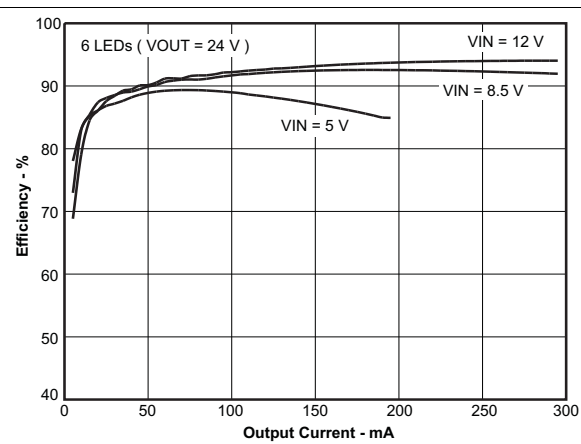

图 4. Switch Current Limit vs Temperature

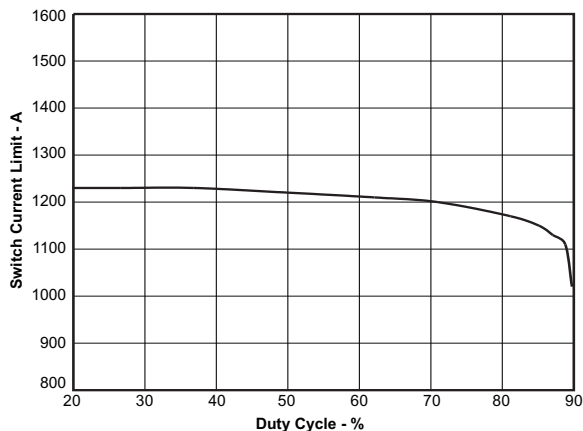

图 5. Switching Waveform

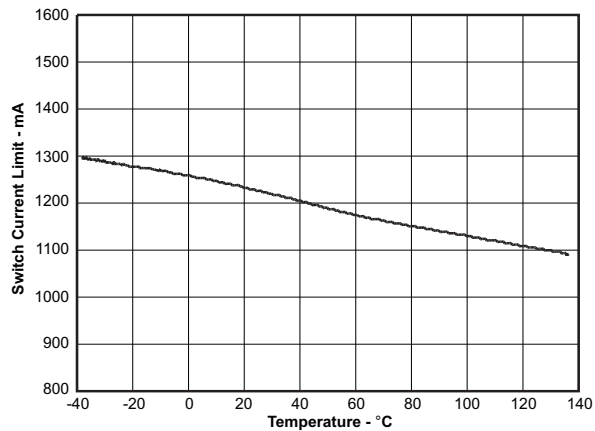

图 6. Start-Up

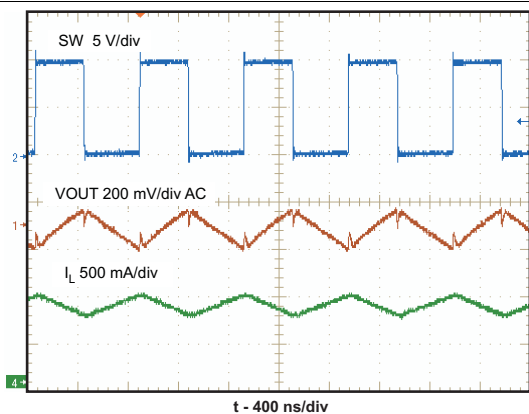

图 7. Open LED Protection

8 Detailed Description

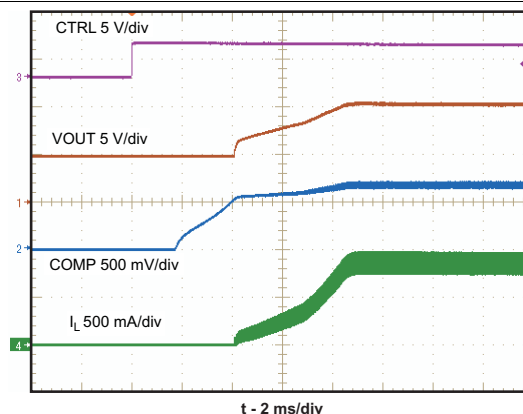
8.1 Overview

The TPS61165 is a high-efficiency, high-output-voltage boost converter in small package size. The device is ideal for driving white LEDs in series. The serial LED connection provides even illumination by sourcing the same output current through all LEDs, eliminating the need for expensive factory calibration. The device integrates 40-V/1.2-A switch FET and operates in pulse width modulation (PWM) with 1.2-MHz fixed switching frequency. (For operation see the [Functional Block Diagram](#).) The duty cycle of the converter is set by the error amplifier output and the current signal applied to the PWM control comparator. The control architecture is based on traditional current-mode control; therefore, slope compensation is added to the current signal to allow stable operation for duty cycles larger than 40%. The feedback loop regulates the FB pin to a low reference voltage (200 mV typical), reducing the power dissipation in the current sense resistor.

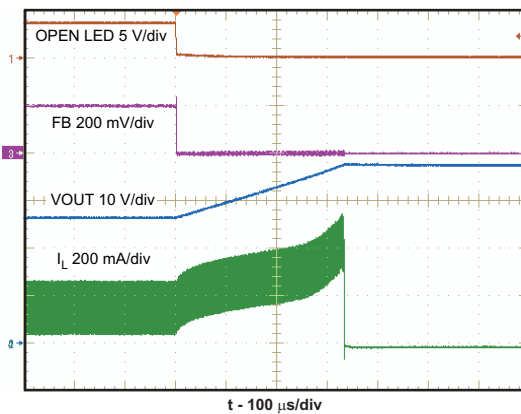
8.2 Functional Block Diagram

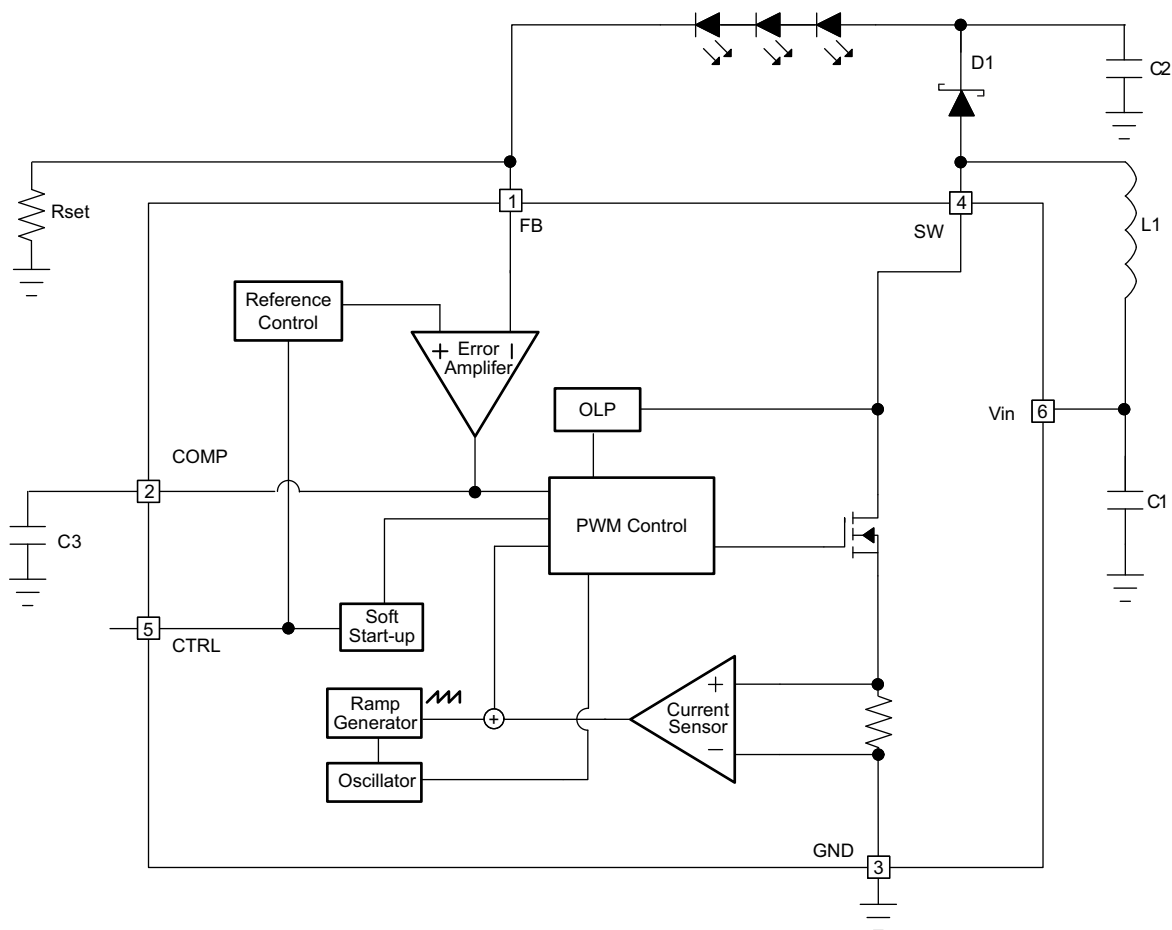

Copyright © 2016, Texas Instruments Incorporated

8.3 Feature Description

8.3.1 Soft Start-Up

Soft-start circuitry is integrated into the device to avoid a high inrush current during start-up. After the device is enabled, the voltage at FB pin ramps up to the reference voltage in 32 steps — each step takes 213 μ s. This ensures that the output voltage rises slowly to reduce the input current. Additionally, for the first 5 msec after the COMP voltage ramps, the current limit of the switch is set to half of the normal current limit specification. During this period, the input current is kept below 700 mA (typical). These two features ensure smooth start-up and minimize the inrush current (see [Figure 6](#)).

8.3.2 Open LED Protection

Open LED protection circuitry prevents device damage as the result of white LED disconnection. The TPS61165 monitors the voltage at the SW pin and FB pin during each switching cycle. The circuitry turns off the switch FET and shuts down the device when both of the following conditions persist for 8 switching clock cycles: (1) the SW voltage exceeds the V_{OVP} threshold, and (2) the FB voltage is less than half of regulation voltage. As a result, the output voltage falls to the level of the input supply. The device remains in shutdown mode until it is enabled by toggling the CTRL pin. The product of the number of external series LEDs and the maximum forward voltage of each LED plus the 200-mV reference voltage does not exceed the 38-V minimum OVP threshold ($N_{LEDs} \times V_{LED(MAX)} + 200 \text{ mV} \leq 38 \text{ V}$).

8.3.3 Undervoltage Lockout

An undervoltage lockout prevents operation of the device at input voltages below typical 2.2 V. When the input voltage is below the undervoltage threshold, the device is shutdown and the internal switch FET is turned off. If the input voltage rises by undervoltage lockout hysteresis, the device restarts.

8.3.4 Thermal Shutdown

An internal thermal shutdown turns off the device when the typical junction temperature of 160°C is exceeded. The device is released from shutdown automatically when the junction temperature decreases by 15°C.

8.4 Device Functional Modes

8.4.1 Shutdown

The TPS61165 device enters shutdown mode when the CTRL voltage is logic low for more than 2.5 ms. During shutdown, the input supply current for the device is less than 1 μ A (maximum). Although the internal FET does not switch in shutdown, there is still a dc current path between the input and the LEDs through the inductor and Schottky diode. The minimum forward voltage of the LED array must exceed the maximum input voltage to ensure that the LEDs remain off in shutdown.

9 Application and Implementation

注

Information in the following applications sections is not part of the TI component specification, and TI does not warrant its accuracy or completeness. TI's customers are responsible for determining suitability of components for their purposes. Customers should validate and test their design implementation to confirm system functionality.

9.1 Application Information

9.1.1 Maximum Output Current

The overcurrent limit in a boost converter limits the maximum input current and thus maximum input power for a given input voltage. Maximum output power is less than maximum input power due to power conversion losses. Therefore, the current limit setting, input voltage, output voltage and efficiency can all change maximum current output. The current limit clamps the peak inductor current; therefore, the ripple has to be subtracted to derive maximum dc current. The ripple current is a function of switching frequency, inductor value and duty cycle. The following equations take into account of all the above factors for maximum output current calculation.

$$I_p = \frac{1}{L \times F_s \times \left(\frac{1}{V_{out} + V_f - V_{in}} + \frac{1}{V_{in}} \right)}$$

where

- I_p = inductor peak to peak ripple
- L = inductor value
- V_f = Schottky diode forward voltage
- F_s = switching frequency
- V_{out} = output voltage of the boost converter. It is equal to the sum of VFB and the voltage drop across LEDs.

$$I_{out_max} = \frac{V_{in} \times (I_{lim} - I_p / 2) \times \eta}{V_{out}}$$

where

- I_{out_max} = Maximum output current of the boost converter
- I_{lim} = overcurrent limit
- η = efficiency

For instance, when V_{IN} is 3 V, 8 LEDs output equivalent to V_{OUT} of 26 V, the inductor is 22 μ H, the Schottky forward voltage is 0.2 V, the maximum output current is then 110 mA in typical condition. When V_{IN} is 5 V, 10 LEDs output equivalent to V_{OUT} of 32 V, the inductor is 22 μ H, the Schottky forward voltage is 0.2 V, the maximum output current is 150 mA in typical condition.

9.1.2 Inductor Selection

Selection of the inductor affects steady state operation as well as transient behavior and loop stability. These factors make it the most important component in power regulator design. There are three important inductor specifications, inductor value, DC resistance and saturation current. Considering inductor value alone is not enough.

The inductor value determines the inductor ripple current. Choose an inductor that can handle the necessary peak current without saturating, according to half of the peak-to-peak ripple current given by 公式 1, pause the inductor DC current given by:

$$I_{in_DC} = \frac{V_{out} \times I_{out}}{V_{in} \times \eta}$$

Application Information (接下页)

Inductor values can have $\pm 20\%$ tolerance with no current bias. When the inductor current approaches saturation level, its inductance can decrease 20% to 35% from the 0A value depending on how the inductor vendor defines saturation current. Using an inductor with a smaller inductance value forces discontinuous PWM when the inductor current ramps down to zero before the end of each switching cycle. This reduces the maximum output current of the boost convert, causes large input voltage ripple, and reduces efficiency. Large inductance value provides much more output current and higher conversion efficiency. For these reasons, a 10- μH to 22- μH inductor value range is recommended. A 22- μH inductor optimized the efficiency for most application while maintaining low inductor peak to peak ripple. 表 2 lists the recommended inductor for the TPS61165. When recommending inductor value, the factory has considered -40% and 20% tolerance from its nominal value.

TPS61165 has built-in slope compensation to avoid subharmonic oscillation associated with current mode control. If the inductor value is lower than 10 μH , the slope compensation may not be adequate, and the loop can be unstable. Therefore, customers need to verify the inductor in their application if it is different from the recommended values.

表 2. Recommended Inductors for TPS61165

PART NUMBER	L (μH)	DCR MAX (m Ω)	SATURATION CURRENT (A)	SIZE (L x W x H mm)	VENDOR
A915_Y-100M	10	90	1.3	5.2 x 5.2 x 3.0	TOKO
VLCF5020T-100M1R1-1	10	237	1.1	5 x 5 x 2.0	TDK
CDRH4D22/HP	10	144	1.2	5 x 5 x 2.4	Sumida
LQH43PN100MR0	10	247	0.84	4.5 x 3.2 x 2.0	Murata

9.1.3 Schottky Diode Selection

The high switching frequency of the TPS61165 demands a high-speed rectification for optimum efficiency. Ensure that the average and peak current rating of the diode exceeds the average output current and peak inductor current. In addition, the reverse breakdown voltage of the diode must exceed the open LED protection voltage. The ONSemiconductor MBR0540 and the ZETEX ZHCS400 are recommended for TPS61165.

9.1.4 Compensation Capacitor Selection

The compensation capacitor C3 (see *Functional Block Diagram*), connected from COMP pin to GND, is used to stabilize the feedback loop of the TPS61165. A 220-nF ceramic capacitor is suitable for most applications.

9.1.5 Input and Output Capacitor Selection

The output capacitor is mainly selected to meet the requirements for the output ripple and loop stability. This ripple voltage is related to the capacitor's capacitance and its equivalent series resistance (ESR). Assuming a capacitor with zero ESR, the minimum capacitance needed for a given ripple can be calculated as shown in 公式 4.

$$C_{\text{out}} = \frac{(V_{\text{out}} - V_{\text{in}}) I_{\text{out}}}{V_{\text{out}} \times F_{\text{s}} \times V_{\text{ripple}}}$$

where

- V_{ripple} = peak-to-peak output ripple (4)

The additional output ripple component caused by ESR is calculated as shown in 公式 4.

$$V_{\text{ripple_ESR}} = I_{\text{out}} \times R_{\text{ESR}} \quad (5)$$

Due to its low ESR, $V_{\text{ripple_ESR}}$ can be neglected for ceramic capacitors, but must be considered if tantalum or electrolytic capacitors are used.

Care must be taken when evaluating a ceramic capacitors derating under dc bias, aging and AC signal. For example, larger form factor capacitors (in 1206 size) have self-resonant frequencies in the range of the switching frequency. So the effective capacitance is significantly lower. The dc bias can also significantly reduce capacitance. Ceramic capacitors can loss as much as 50% of its capacitance at its rated voltage. Therefore, leave the margin on the voltage rating to ensure adequate capacitance at the required output voltage.

The capacitor in the range of 1 μF to 4.7 μF is recommended for input side. The output requires a capacitor in the range of 1 μF to 10 μF . The output capacitor affects the loop stability of the boost regulator. If the output capacitor is below the range, the boost regulator can potentially become unstable.

The popular vendors for high value ceramic capacitors are:

TDK (<http://www.component.tdk.com/components.php>)

Murata (<http://www.murata.com/cap/index.html>)

9.2 Typical Applications

9.2.1 TPS61165 Typical Application

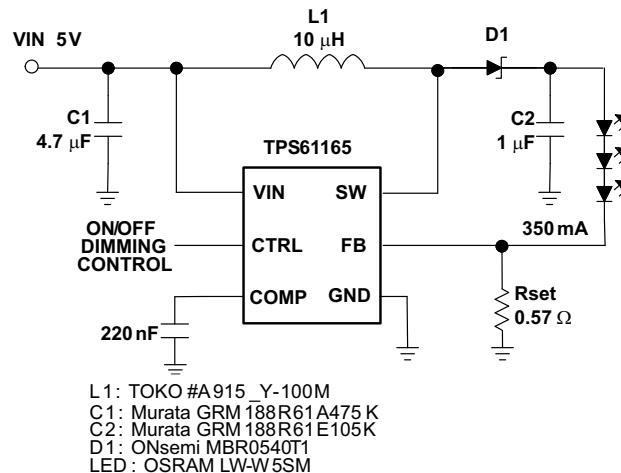

Copyright © 2016, Texas Instruments Incorporated

图 8. TPS61165 Typical Application

9.2.1.1 Design Requirements

DESIGN PARAMETERS	EXAMPLE VALUE
Brightness control	PWM dimming
LED current	357 mA

9.2.1.2 Detailed Design Procedure

9.2.1.2.1 LED Brightness Dimming Mode Selection

The TPS61165 features two dimming modes: PWM dimming and EasyScale one-wire digital dimming.

The CTRL pin is used for the control input for both dimming modes, PWM dimming and the 1 wire dimming. The dimming mode for the TPS61165 is selected each time the device is enabled. The default dimming mode is PWM dimming. To enter 1 wire mode, the following digital pattern on the CTRL pin must be recognized by the device every time the device starts from the shutdown mode.

1. Pull CTRL pin high to enable the TPS61165, and to start the 1 wire detection window.
2. After the EasyScale detection delay ($t_{\text{es_delay}}$, 100 μs) expires, drive CTRL low for more than the EasyScale detection time ($t_{\text{es_det}}$, 260 μs). $t_{\text{es_det}}$ and $t_{\text{es_delay}}$ values are conservative to guarantee the EasyScale detection taking into account the process and clock variations. To ensure not to enter EasyScale mode, please make sure CTRL pin is never held low for more than 160 μs .
3. The CTRL pin has to be low for more than EasyScale detection time before the EasyScale detection window ($t_{\text{es_win}}$, 1 msec) expires. EasyScale detection window starts from the first CTRL pin low to high transition.

The device immediately enters the one-wire mode once the preceding three conditions are met. The EasyScale communication can start before the detection window expires. Once the dimming mode is programmed, it can not be changed without another start up. This means the device needs to be shutdown by pulling the CTRL low for 2.5 ms and restarts. See 图 9 for a graphical explanation.



图 9. Dimming Mode Detection and Soft Start PWM Brightness Dimming

9.2.1.2.2 PWM Brightness Dimming

When the CTRL pin is constantly high, the FB voltage is regulated to 200 mV typically. However, the CTRL pin allows a PWM signal to reduce this regulation voltage; therefore, it achieves LED brightness dimming. The relationship between the duty cycle and FB voltage is shown in 公式 6.

$$V_{FB} = \text{Duty} \times 200 \text{ mV}$$

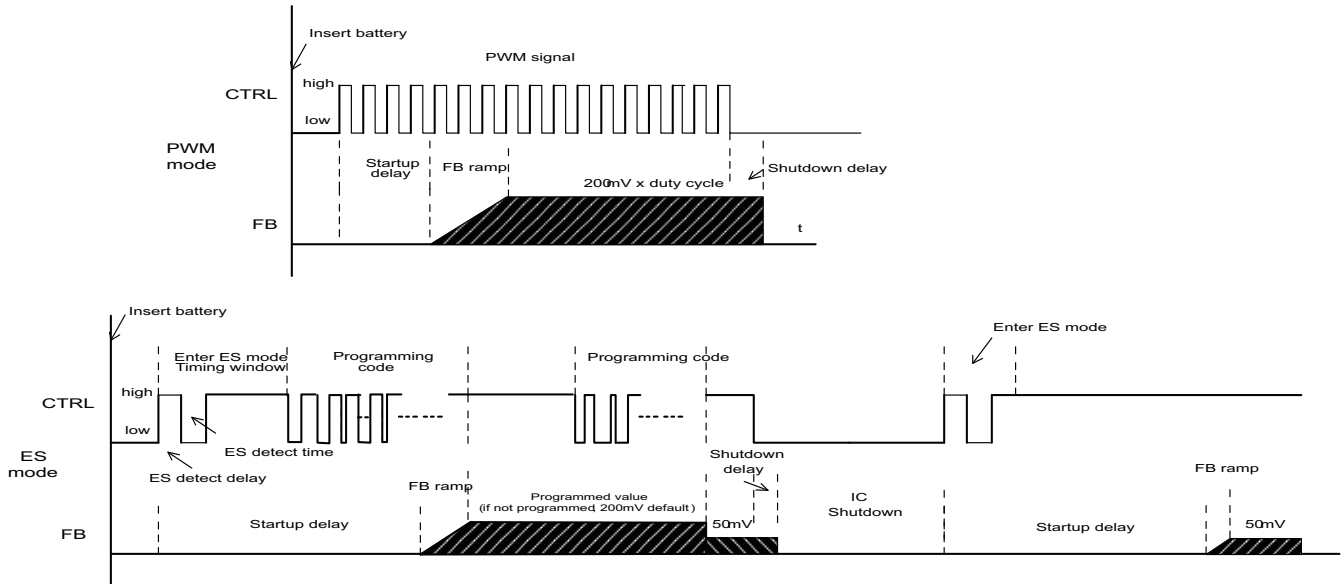
where

- Duty = duty cycle of the PWM signal
 - 200 mV = internal reference voltage
- (6)

As shown in 图 10, the device chops up the internal 200-mV reference voltage at the duty cycle of the PWM signal. The pulse signal is then filtered by an internal low pass filter. The output of the filter is connected to the error amplifier as the reference voltage for the FB pin regulation. Therefore, although a PWM signal is used for brightness dimming, only the WLED DC current is modulated, which is often referred as analog dimming. This eliminates the audible noise which often occurs when the LED current is pulsed in replica of the frequency and duty cycle of PWM control. Unlike other methods which filters the PWM signal for analog dimming, TPS61165 regulation voltage is independent of the PWM logic voltage level which often has large variations.

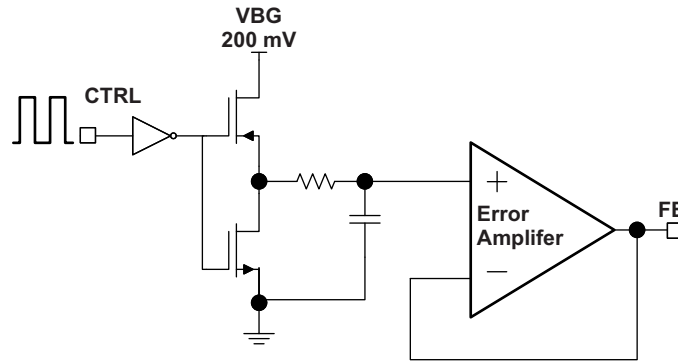

Copyright © 2016, Texas Instruments Incorporated

图 10. Block Diagram of Programmable FB Voltage Using PWM Signal

For optimum performance, use the PWM dimming frequency in the range of 6.5 kHz to 100 kHz. The requirement of minimum dimming frequency comes from the EasyScale detection delay and detection time specification in the dimming mode selection. Because the CTRL pin is logic only pin, adding an external RC filter applied to the pin does not work.

To use lower PWM dimming, add external RC network connected to the FB pin as shown in [Additional Application Circuits](#).

9.2.1.2.3 Digital One-Wire Brightness Dimming

The CTRL pin features a simple digital interface to allow digital brightness control. The digital dimming can save the processor power and battery life as it does not require a PWM signal all the time, and the processor can enter idle mode if available.

The TPS61165 adopts the EasyScale protocol for the digital dimming, which can program the FB voltage to any of the 32 steps with single command. The step increment increases with the voltage to produce pseudo logarithmic curve for the brightness step. See [表 3](#) for the FB pin voltage steps. The default step is full scale when the device is first enabled ($V_{FB} = 200\text{ mV}$). The programmed reference voltage is stored in an internal register and is not changed by pulling CTRL low for 2.5 ms and then re-enabling the device by taking CTRL high. A power reset clears the register value and reset it to default.

9.2.1.2.4 EasyScale: One-Wire Digital Dimming

EasyScale is a simple but flexible one-pin interface to configure the FB voltage. The interface is based on a master-slave structure, where the master is typically a microcontroller or application processor. [图 11](#) and [表 4](#) give an overview of the protocol. The protocol consists of a device specific address byte and a data byte. The device specific address byte is fixed to 72 hex. The data byte consists of five bits for information, two address bits, and the RFA bit. The RFA bit set to high indicates the *Request for Acknowledge* condition. The Acknowledge condition is only applied if the protocol was received correctly. The advantage of EasyScale compared with other on-pin interfaces is that its bit detection is in a large extent independent from the bit transmission rate. It can automatically detect bit rates between 1.7 kBit/sec and up to 160 kBit/sec.

表 3. Selectable FB Voltage

	FB Voltage (mV)	D4	D3	D2	D1	D0
0	0	0	0	0	0	0
1	5	0	0	0	0	1
2	8	0	0	0	1	0
3	11	0	0	0	1	1
4	14	0	0	1	0	0
5	17	0	0	1	0	1

表 3. Selectable FB Voltage (接下页)

	FB Voltage (mV)	D4	D3	D2	D1	D0
6	20	0	0	1	1	0
7	23	0	0	1	1	1
8	26	0	1	0	0	0
9	29	0	1	0	0	1
10	32	0	1	0	1	0
11	35	0	1	0	1	1
12	38	0	1	1	0	0
13	44	0	1	1	0	1
14	50	0	1	1	1	0
15	56	0	1	1	1	1
16	62	1	0	0	0	0
17	68	1	0	0	0	1
18	74	1	0	0	1	0
19	80	1	0	0	1	1
20	86	1	0	1	0	0
21	92	1	0	1	0	1
22	98	1	0	1	1	0
23	104	1	0	1	1	1
24	116	1	1	0	0	0
25	128	1	1	0	0	1
26	140	1	1	0	1	0
27	152	1	1	0	1	1
28	164	1	1	1	0	0
29	176	1	1	1	0	1
30	188	1	1	1	1	0
31	200	1	1	1	1	1

DATA IN



图 11. EasyScale Protocol Overview

表 4. EasyScale Bit Description

BYTE	BIT NUMBER	NAME	TRANSMISSION DIRECTION	DESCRIPTION
Device Address Byte 72 hex	7	DA7	IN	0 MSB device address
	6	DA6		1
	5	DA5		1
	4	DA4		1
	3	DA3		0
	2	DA2		0
	1	DA1		1
	0	DA0		0 LSB device address

表 4. EasyScale Bit Description (接下页)

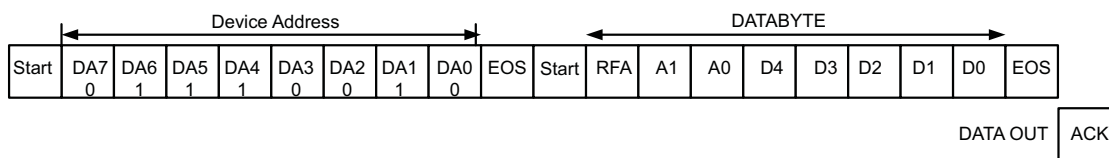
BYTE	BIT NUMBER	NAME	TRANSMISSION DIRECTION	DESCRIPTION
Data byte	7 (MSB)	RFA	IN	Request for acknowledge. If high, acknowledge is applied by device
	6	A1		0 Address bit 1
	5	A0		0 Address bit 0
	4	D4		Data bit 4
	3	D3		Data bit 3
	2	D2		Data bit 2
	1	D1		Data bit 1
	0 (LSB)	D0		Data bit 0
		ACK	OUT	Acknowledge condition active 0, this condition is only applied in case RFA bit is set. Open drain output, line must be pulled high by the host with a pullup resistor. This feature can only be used if the master has an open-drain output stage. In case of a push-pull output stage Acknowledge condition may not be requested!

EasyScale Timing, without acknowledge RFA = 0

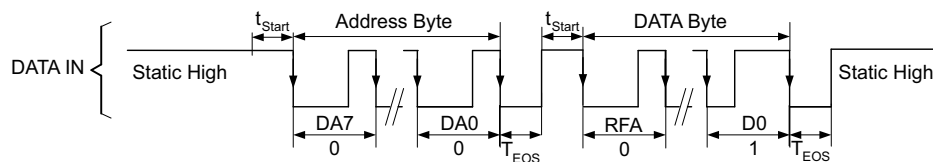

EasyScale Timing, with acknowledge RFA = 1



图 12. EasyScale — Bit Coding

All bits are transmitted MSB first and LSB last. 图 12 shows the protocol without acknowledge request (Bit RFA = 0), 图 12 with acknowledge (Bit RFA = 1) request. Prior to both bytes, device address byte and data byte, a start condition must be applied. For this, the CTRL pin must be pulled high for at least t_{start} (2 μ s) before the bit transmission starts with the falling edge. If the CTRL pin is already at a high level, no start condition is needed prior to the device address byte. The transmission of each byte is closed with an End of Stream condition for at least t_{EOS} (2 μ s).

The bit detection is based on a Logic Detection scheme, where the criterion is the relation between t_{LOW} and t_{HIGH} . It can be simplified to:

High Bit: $t_{HIGH} > t_{LOW}$, but with t_{HIGH} at least $2x t_{LOW}$, see 图 12.

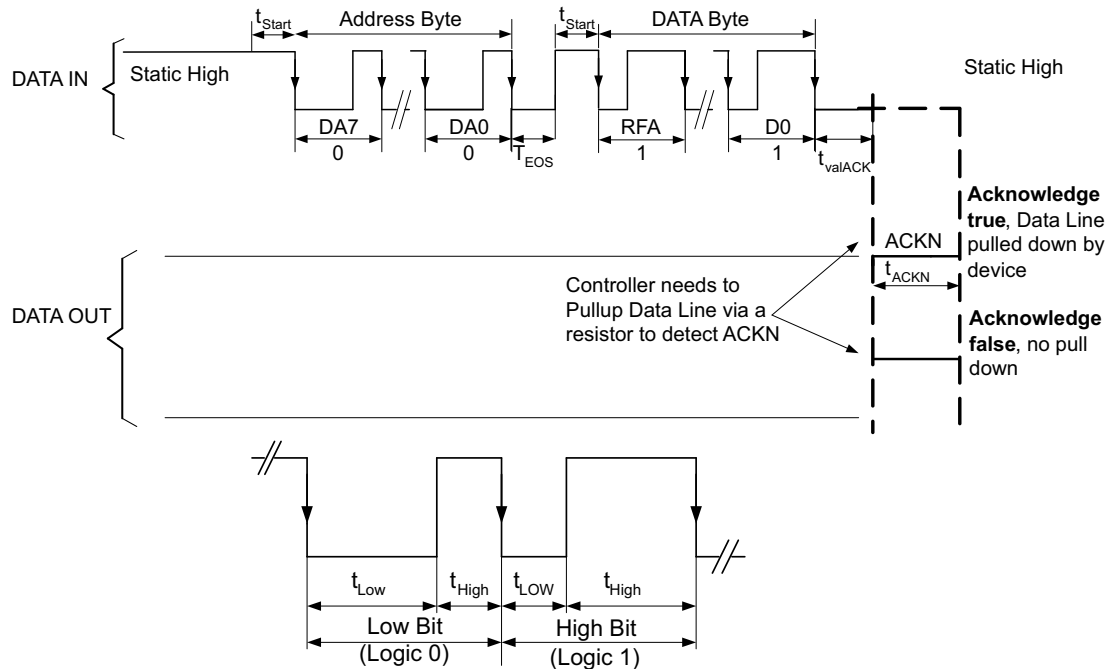
Low Bit: $t_{HIGH} < t_{LOW}$, but with t_{LOW} at least $2x t_{HIGH}$, see 图 12.

The bit detection starts with a falling edge on the CTRL pin and ends with the next falling edge. Depending on the relation between t_{HIGH} and t_{LOW} , the logic 0 or 1 is detected.

The acknowledge condition is only applied if:

- Acknowledge is requested by a set RFA bit.
- The transmitted device address matches with the device address of the device.
- 16 bits is received correctly.

If the device turns on the internal ACKN-MOSFET and pulls the CTRL pin low for the time t_{ACKN} , which is 512 μs maximum then the Acknowledge condition is valid after an internal delay time t_{valACK} . This means that the internal ACKN-MOSFET is turned on after t_{valACK} , when the last falling edge of the protocol was detected. The master controller keeps the line low in this period. The master device can detect the acknowledge condition with its input by releasing the CTRL pin after t_{valACK} and read back a logic 0. The CTRL pin can be used again after the acknowledge condition ends.

The acknowledge condition may be requested only if the master device has an open drain output. For a push-pull output stage, the use a series resistor in the CTRL line to limit the current to 500 μA is recommended for such cases as:

- accidentally requested acknowledge, or
- to protect the internal ACKN-MOSFET.

9.2.1.2.5 Current Program

The FB voltage is regulated by a low 0.2-V reference voltage. The LED current is programmed externally using a current-sense resistor in series with the LED string. The value of the R_{SET} is calculated using 公式 7.

$$I_{LED} = \frac{V_{FB}}{R_{SET}}$$

where

- I_{LED} = output current of LEDs
- V_{FB} = regulated voltage of FB
- R_{SET} = current sense resistor

(7)

The output current tolerance depends on the FB accuracy and the current sensor resistor accuracy.

9.2.1.3 Application Curves

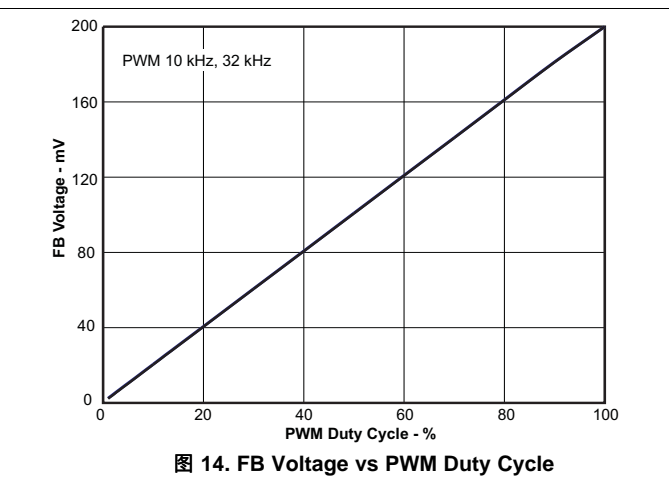
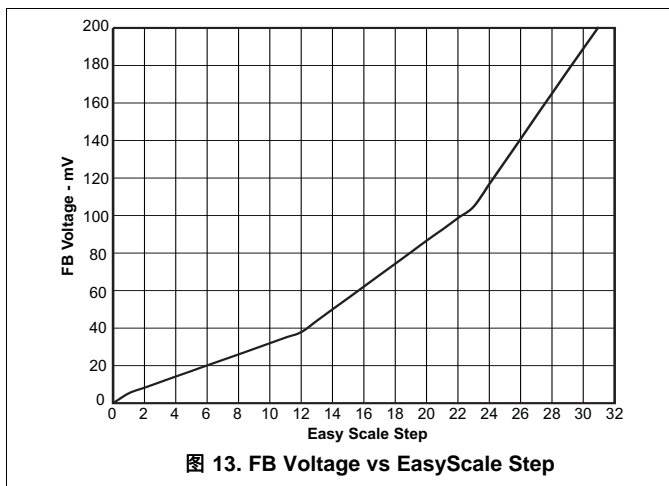

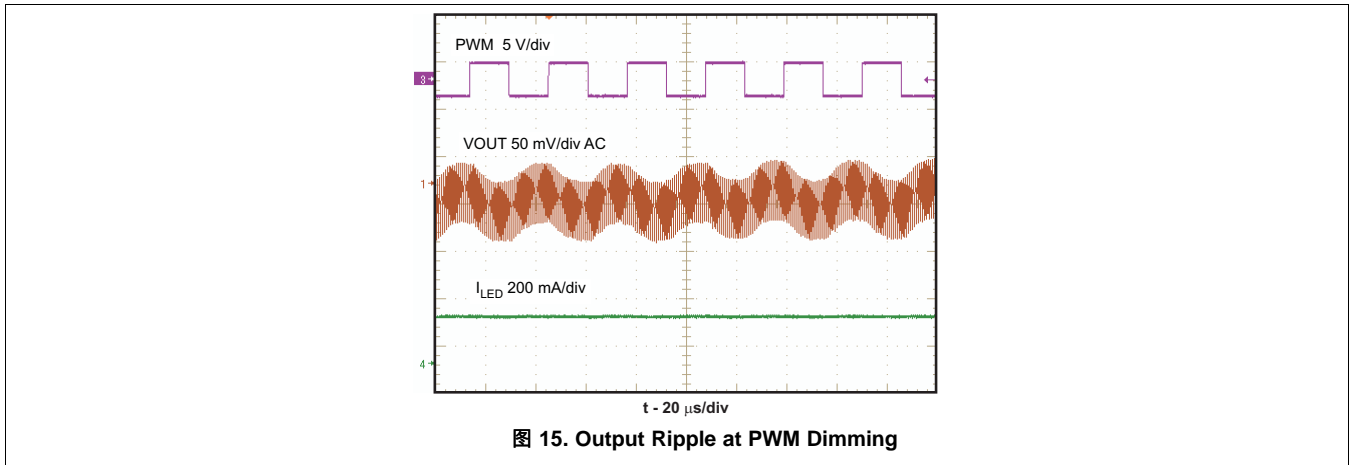

9.2.2 Additional Application Circuits

The TPS61165 can be configured to drive three high-brightness LEDs using an external PWM dimming network. [图 16](#) shows an example application circuit.

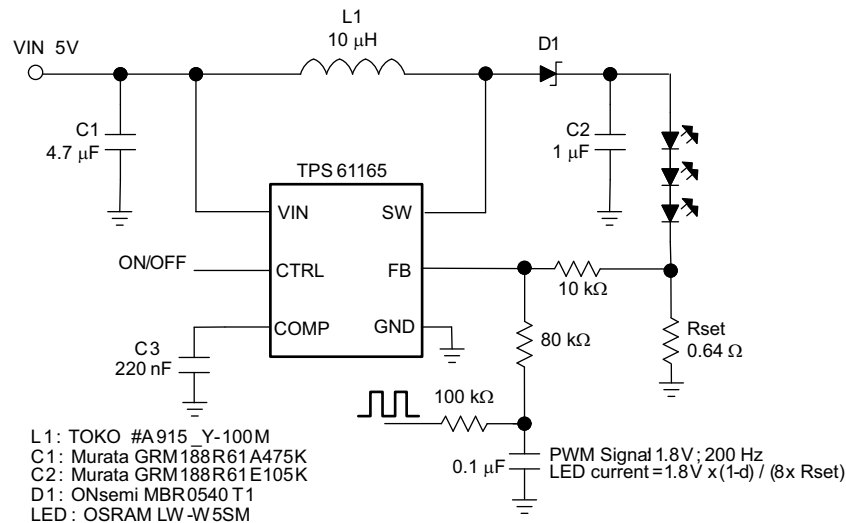

Copyright © 2016, Texas Instruments Incorporated

图 16. Drive Three High-Brightness LEDs With External PWM Dimming Network

The TPS61165 can be configured to drive nine strings of three LEDs for media form factor displays. 图 17 shows an example application circuit.

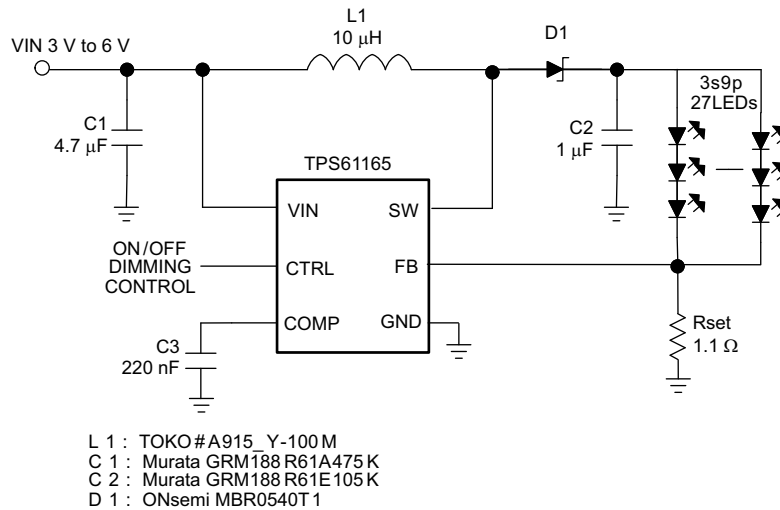

Copyright © 2016, Texas Instruments Incorporated

图 17. Drive 27 LEDs for Media Form-Factor Display

The TPS61165 can be configured to drive six high-brightness LEDs in series. 图 18 provides an example applications circuit.

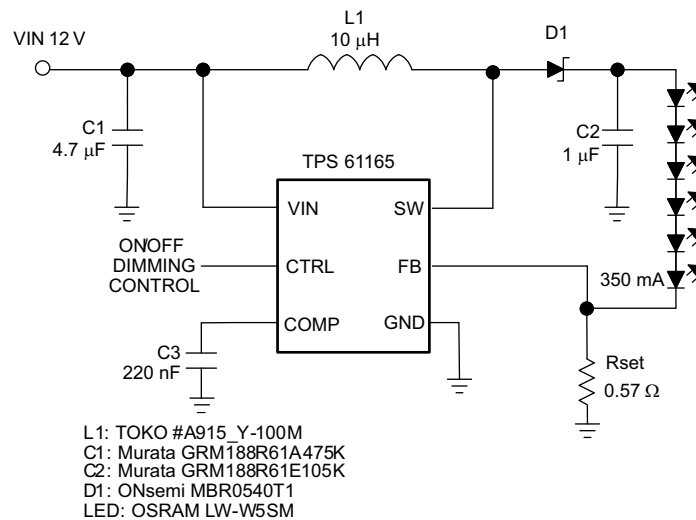

Copyright © 2016, Texas Instruments Incorporated

图 18. Drive Six High-Brightness LEDs

The TPS61165 can be configured to drive four high-brightness LEDs using SEPIC topology. An example application circuit can be found in [Figure 19](#).

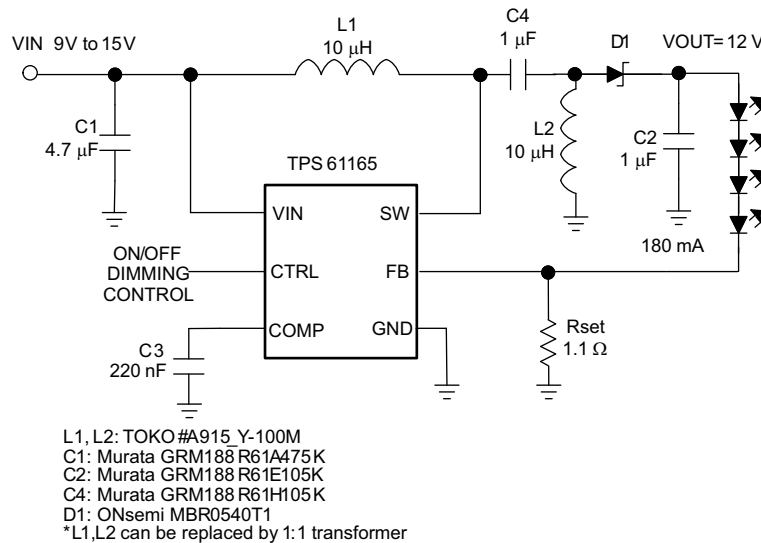

Copyright © 2016, Texas Instruments Incorporated

图 19. Drive Four High-Brightness LED With SEPIC Topology

9.3 Do's and Don'ts

There is a known issue with the TPS61165 when using the EasyScale interface to increase the feedback voltage. When V_{FB} is increased from 0 mV to any value above 0 mV, some ICs do not properly soft start during this transition and the voltage on their SW pin overshoots. If the overshoot exceeds the absolute maximum voltage rating on the SW pin, the device is damaged.

With VFB set below 10 mV through EasyScale, the parasitic offsets on the input pins of the internal transconductance amplifier determine the value of output of the amplifier. Device process variations are causing the offset to be larger and in the opposite polarity than expected. If the amplifier's output is already high prior to a transition from $V_{FB} = 0$ mV to any other voltage, then the modulator turns on full, bypassing soft start, and causes the SW pin and output voltage to overshoot.

To avoid this issue do not use EasyScale to change the feedback voltage from 0 mV, effectively disabling the device, to any other voltage. One alternative is to start with $V_{FB} = 10$ mV and go to a higher voltage. Another alternative is to disable the device by taking the CTRL pin low for 2.5 ms and then re-enter EasyScale to force a soft start from $V_{FB} = 0$ mV to the default 200 mV.

10 Power Supply Recommendations

The TPS61165 requires a single supply input voltage. This voltage can range from 3 V to 18 V and be able to supply enough current for a given application.

11 Layout

11.1 Layout Guidelines

As for all switching power supplies, especially those high frequency and high current ones, layout is an important design step. If layout is not carefully done, the regulator could suffer from instability as well as noise problems. To reduce switching losses, the SW pin rise and fall times are made as short as possible. To prevent radiation of high frequency resonance problems, proper layout of the high frequency switching path is essential. Minimize the length and area of all traces connected to the SW pin, and always use a ground plane under the switching regulator to minimize inter-plane coupling. The loop including the PWM switch, Schottky diode, and output capacitor, contains high current rising and falling in nanosecond and must be kept as short as possible. The input capacitor must be close to both the VIN pin and the GND pin to reduce the device supply ripple. 图 20 shows a sample layout.

11.2 Layout Example



图 20. Layout Recommendation

11.3 Thermal Considerations

The maximum device junction temperature must be restricted to 125°C under normal operating conditions. This restriction limits the power dissipation of the TPS61165. Calculate the maximum allowable dissipation, $P_{D(max)}$, and keep the actual dissipation less than or equal to $P_{D(max)}$. The maximum-power-dissipation limit is determined using [公式 8](#):

$$P_{D(max)} = \frac{125^{\circ}\text{C} - T_A}{R_{\theta JA}}$$

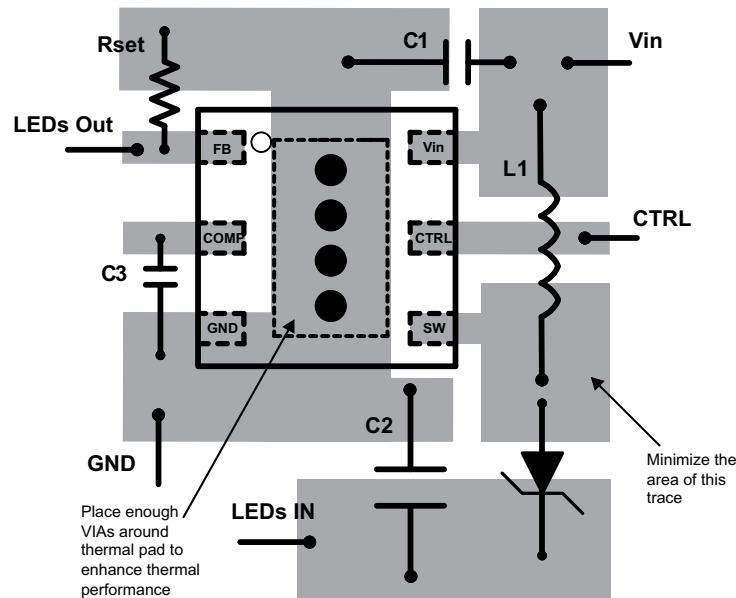
where

- T_A is the maximum ambient temperature for the application
- $R_{\theta JA}$ is the thermal resistance junction-to-ambient given in [Thermal Information](#) (8)

The TPS61165 comes in a thermally enhanced QFN package. This package includes a thermal pad that improves the thermal capabilities of the package. The $R_{\theta JA}$ of the QFN package greatly depends on the PCB layout and thermal pad connection. The thermal pad must be soldered to the analog ground on the PCB. Using thermal vias underneath the thermal pad as illustrated in the layout example. Also see the [QFN/SON PCB Attachment](#) application report ([SLUA271](#)).

12 器件和文档支持

12.1 器件支持

12.1.1 第三方产品免责声明

TI 发布的与第三方产品或服务有关的信息，不能构成与此类产品或服务或保修的适用性有关的认可，不能构成此类产品或服务单独或与任何 TI 产品或服务一起的表示或认可。

12.2 文档支持

12.2.1 相关文档

请参阅如下相关文档：

《QFN/SON PCB 连接》（文献编号：[SLUA271](#)）

12.3 社区资源

下列链接提供到 TI 社区资源的连接。链接的内容由各个分销商“按照原样”提供。这些内容并不构成 TI 技术规范，并且不一定反映 TI 的观点；请参阅 TI 的《使用条款》。

TI E2E™ Online Community *TI's Engineer-to-Engineer (E2E) Community*. Created to foster collaboration among engineers. At [e2e.ti.com](#), you can ask questions, share knowledge, explore ideas and help solve problems with fellow engineers.

Design Support *TI's Design Support* Quickly find helpful E2E forums along with design support tools and contact information for technical support.

12.4 商标

EasyScale, E2E are trademarks of Texas Instruments.
All other trademarks are the property of their respective owners.

12.5 静电放电警告



这些装置包含有限的内置 ESD 保护。存储或装卸时，应将导线一起截短或将装置放置于导电泡棉中，以防止 MOS 门极遭受静电损伤。

12.6 术语表

[SLYZ022](#) — TI 术语表。

这份术语表列出并解释术语、缩写和定义。

13 机械、封装和可订购信息

以下页面包含机械、封装和可订购信息。这些信息是指定器件的最新可用数据。数据如有变更，恕不另行通知，且不会对此文档进行修订。如需获取此数据表的浏览器版本，请查阅左侧的导航栏。

PACKAGING INFORMATION

Orderable Device	Status (1)	Package Type	Package Drawing	Pins	Package Qty	Eco Plan (2)	Lead finish/ Ball material (6)	MSL Peak Temp (3)	Op Temp (°C)	Device Marking (4/5)	Samples
HPA00735DRVR	ACTIVE	WSON	DRV	6	3000	RoHS & Green	NIPDAU	Level-2-260C-1 YEAR	-40 to 85	CCQ	Samples
TPS61165DBVR	ACTIVE	SOT-23	DBV	6	3000	RoHS & Green	NIPDAU	Level-1-260C-UNLIM	-40 to 85	DAK	Samples
TPS61165DBVT	ACTIVE	SOT-23	DBV	6	250	RoHS & Green	NIPDAU	Level-1-260C-UNLIM	-40 to 85	DAK	Samples
TPS61165DRVR	ACTIVE	WSON	DRV	6	3000	RoHS & Green	NIPDAU NIPDAUAG	Level-2-260C-1 YEAR	-40 to 85	CCQ	Samples
TPS61165DRVRG4	ACTIVE	WSON	DRV	6	3000	RoHS & Green	NIPDAU	Level-2-260C-1 YEAR	-40 to 85	CCQ	Samples
TPS61165DRVT	ACTIVE	WSON	DRV	6	250	RoHS & Green	NIPDAU NIPDAUAG	Level-2-260C-1 YEAR	-40 to 85	CCQ	Samples
TPS61165DRVTG4	ACTIVE	WSON	DRV	6	250	RoHS & Green	NIPDAU	Level-2-260C-1 YEAR	-40 to 85	CCQ	Samples

(1) The marketing status values are defined as follows:

ACTIVE: Product device recommended for new designs.

LIFEBUY: TI has announced that the device will be discontinued, and a lifetime-buy period is in effect.

NRND: Not recommended for new designs. Device is in production to support existing customers, but TI does not recommend using this part in a new design.

PREVIEW: Device has been announced but is not in production. Samples may or may not be available.

OBSOLETE: TI has discontinued the production of the device.

(2) **RoHS:** TI defines "RoHS" to mean semiconductor products that are compliant with the current EU RoHS requirements for all 10 RoHS substances, including the requirement that RoHS substance do not exceed 0.1% by weight in homogeneous materials. Where designed to be soldered at high temperatures, "RoHS" products are suitable for use in specified lead-free processes. TI may reference these types of products as "Pb-Free".

RoHS Exempt: TI defines "RoHS Exempt" to mean products that contain lead but are compliant with EU RoHS pursuant to a specific EU RoHS exemption.

Green: TI defines "Green" to mean the content of Chlorine (Cl) and Bromine (Br) based flame retardants meet JS709B low halogen requirements of <=1000ppm threshold. Antimony trioxide based flame retardants must also meet the <=1000ppm threshold requirement.

(3) MSL, Peak Temp. - The Moisture Sensitivity Level rating according to the JEDEC industry standard classifications, and peak solder temperature.

(4) There may be additional marking, which relates to the logo, the lot trace code information, or the environmental category on the device.

(5) Multiple Device Markings will be inside parentheses. Only one Device Marking contained in parentheses and separated by a "~" will appear on a device. If a line is indented then it is a continuation of the previous line and the two combined represent the entire Device Marking for that device.

⁽⁶⁾ Lead finish/Ball material - Orderable Devices may have multiple material finish options. Finish options are separated by a vertical ruled line. Lead finish/Ball material values may wrap to two lines if the finish value exceeds the maximum column width.

Important Information and Disclaimer:The information provided on this page represents TI's knowledge and belief as of the date that it is provided. TI bases its knowledge and belief on information provided by third parties, and makes no representation or warranty as to the accuracy of such information. Efforts are underway to better integrate information from third parties. TI has taken and continues to take reasonable steps to provide representative and accurate information but may not have conducted destructive testing or chemical analysis on incoming materials and chemicals. TI and TI suppliers consider certain information to be proprietary, and thus CAS numbers and other limited information may not be available for release.

In no event shall TI's liability arising out of such information exceed the total purchase price of the TI part(s) at issue in this document sold by TI to Customer on an annual basis.

TAPE AND REEL INFORMATION



QUADRANT ASSIGNMENTS FOR PIN 1 ORIENTATION IN TAPE



*All dimensions are nominal

Device	Package Type	Package Drawing	Pins	SPQ	Reel Diameter (mm)	Reel Width W1 (mm)	A0 (mm)	B0 (mm)	K0 (mm)	P1 (mm)	W (mm)	Pin1 Quadrant
TPS61165DBVR	SOT-23	DBV	6	3000	179.0	8.4	3.2	3.2	1.4	4.0	8.0	Q3
TPS61165DBVT	SOT-23	DBV	6	250	179.0	8.4	3.2	3.2	1.4	4.0	8.0	Q3
TPS61165DRVR	WSO	DRV	6	3000	180.0	8.4	2.3	2.3	1.15	4.0	8.0	Q2
TPS61165DRVT	WSO	DRV	6	250	180.0	8.4	2.3	2.3	1.15	4.0	8.0	Q2

TAPE AND REEL BOX DIMENSIONS

*All dimensions are nominal

Device	Package Type	Package Drawing	Pins	SPQ	Length (mm)	Width (mm)	Height (mm)
TPS61165DBVR	SOT-23	DBV	6	3000	200.0	183.0	25.0
TPS61165DBVT	SOT-23	DBV	6	250	200.0	183.0	25.0
TPS61165DRVR	WSON	DRV	6	3000	210.0	185.0	35.0
TPS61165DRVT	WSON	DRV	6	250	210.0	185.0	35.0

GENERIC PACKAGE VIEW

DRV 6

WSON - 0.8 mm max height

PLASTIC SMALL OUTLINE - NO LEAD



Images above are just a representation of the package family, actual package may vary.
Refer to the product data sheet for package details.

4206925/F



4222173/B 04/2018

NOTES:

1. All linear dimensions are in millimeters. Any dimensions in parenthesis are for reference only. Dimensioning and tolerancing per ASME Y14.5M.
2. This drawing is subject to change without notice.
3. The package thermal pad must be soldered to the printed circuit board for thermal and mechanical performance.

EXAMPLE STENCIL DESIGN

DRV0006A

WSON - 0.8 mm max height

PLASTIC SMALL OUTLINE - NO LEAD



SOLDER PASTE EXAMPLE
BASED ON 0.125 mm THICK STENCIL

EXPOSED PAD #7
88% PRINTED SOLDER COVERAGE BY AREA UNDER PACKAGE
SCALE:30X

4222173/B 04/2018

NOTES: (continued)

6. Laser cutting apertures with trapezoidal walls and rounded corners may offer better paste release. IPC-7525 may have alternate design recommendations.

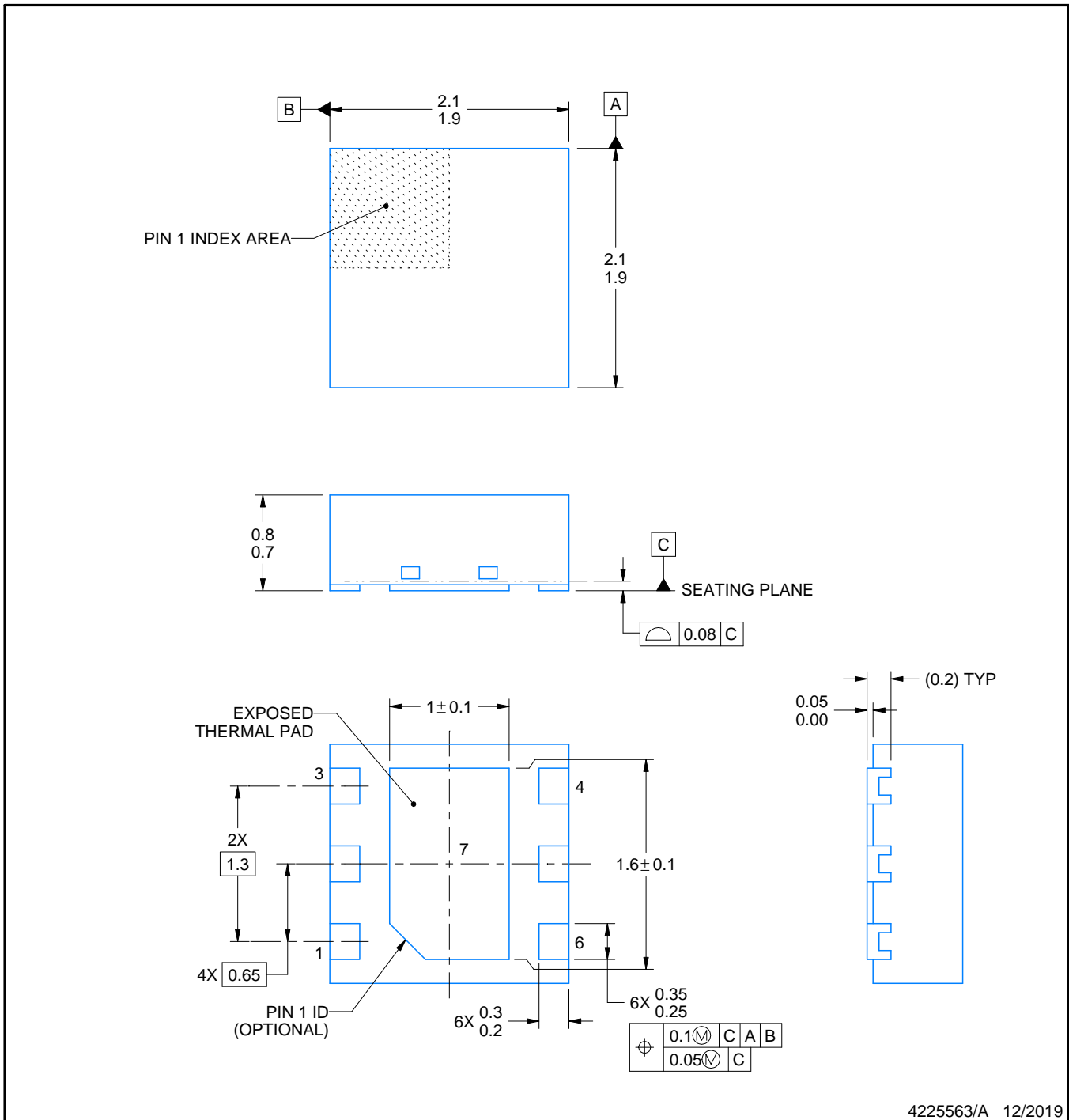
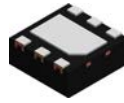

NOTES:

1. All linear dimensions are in millimeters. Any dimensions in parenthesis are for reference only. Dimensioning and tolerancing per ASME Y14.5M.
2. This drawing is subject to change without notice.
3. The package thermal pad must be soldered to the printed circuit board for thermal and mechanical performance.

EXAMPLE BOARD LAYOUT

DRV0006D

WSON - 0.8 mm max height

PLASTIC SMALL OUTLINE - NO LEAD

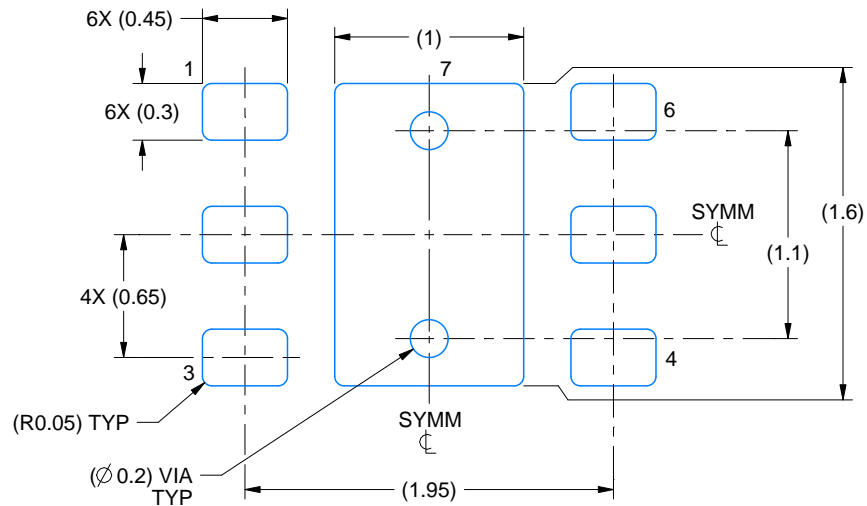

LAND PATTERN EXAMPLE
EXPOSED METAL SHOWN
SCALE:25X

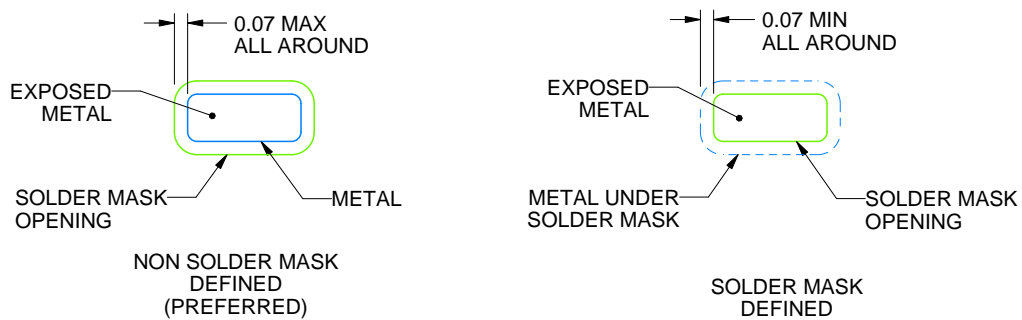

SOLDER MASK DETAILS

4225563/A 12/2019

NOTES: (continued)

4. This package is designed to be soldered to a thermal pad on the board. For more information, see Texas Instruments literature number SLUA271 (www.ti.com/lit/sluea271).
5. Vias are optional depending on application, refer to device data sheet. If some or all are implemented, recommended via locations are shown.

EXAMPLE STENCIL DESIGN

DRV0006D

WSON - 0.8 mm max height

PLASTIC SMALL OUTLINE - NO LEAD



SOLDER PASTE EXAMPLE
BASED ON 0.125 mm THICK STENCIL

EXPOSED PAD #7
88% PRINTED SOLDER COVERAGE BY AREA UNDER PACKAGE
SCALE:30X

4225563/A 12/2019

NOTES: (continued)

6. Laser cutting apertures with trapezoidal walls and rounded corners may offer better paste release. IPC-7525 may have alternate design recommendations.

DBV0006A



PACKAGE OUTLINE

SOT-23 - 1.45 mm max height

SMALL OUTLINE TRANSISTOR

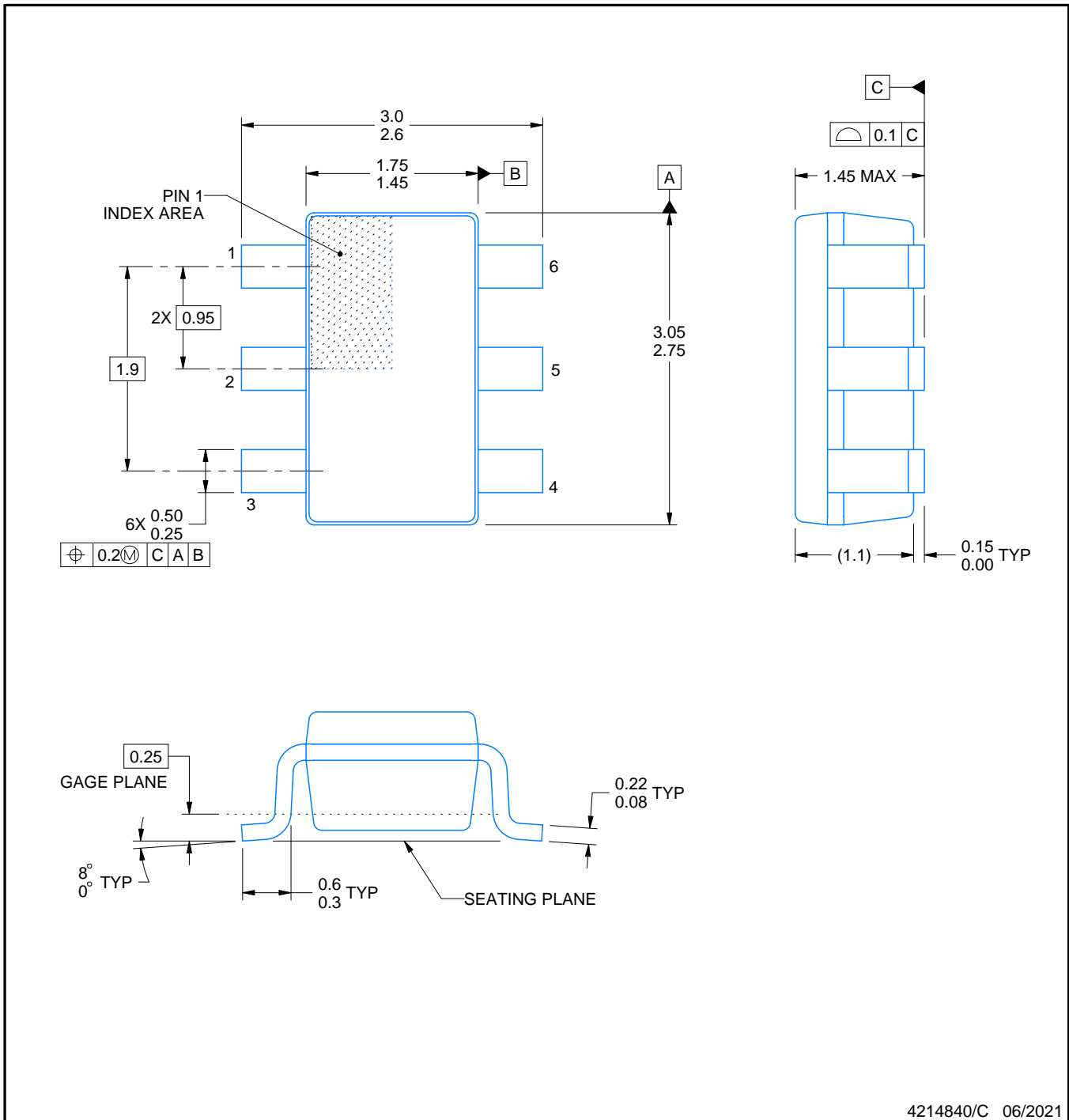

4214840/C 06/2021

NOTES:

1. All linear dimensions are in millimeters. Any dimensions in parenthesis are for reference only. Dimensioning and tolerancing per ASME Y14.5M.
2. This drawing is subject to change without notice.
3. Body dimensions do not include mold flash or protrusion. Mold flash and protrusion shall not exceed 0.25 per side.
4. Leads 1,2,3 may be wider than leads 4,5,6 for package orientation.
5. Reference JEDEC MO-178.

EXAMPLE BOARD LAYOUT

DBV0006A

SOT-23 - 1.45 mm max height

SMALL OUTLINE TRANSISTOR

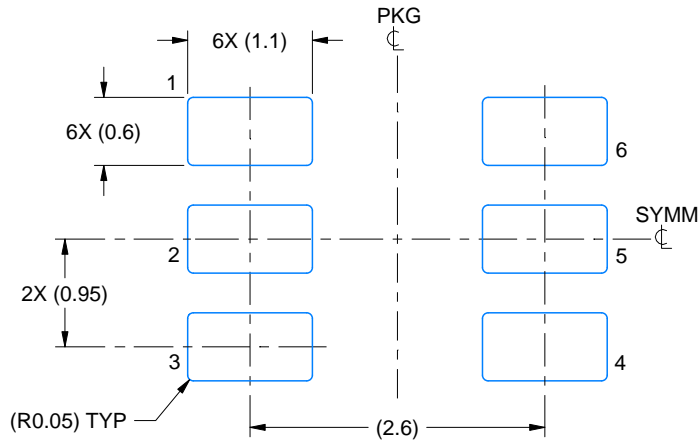

LAND PATTERN EXAMPLE
EXPOSED METAL SHOWN
SCALE:15X

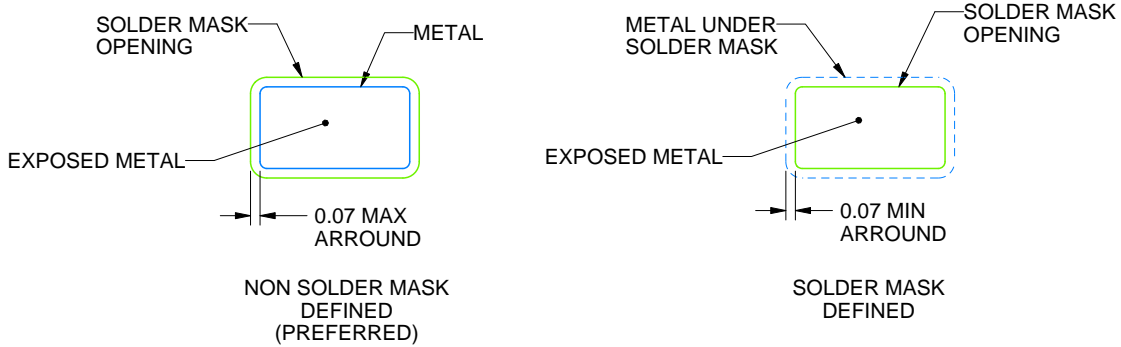

SOLDER MASK DETAILS

4214840/C 06/2021

NOTES: (continued)

- 6. Publication IPC-7351 may have alternate designs.
- 7. Solder mask tolerances between and around signal pads can vary based on board fabrication site.

EXAMPLE STENCIL DESIGN

DBV0006A

SOT-23 - 1.45 mm max height

SMALL OUTLINE TRANSISTOR

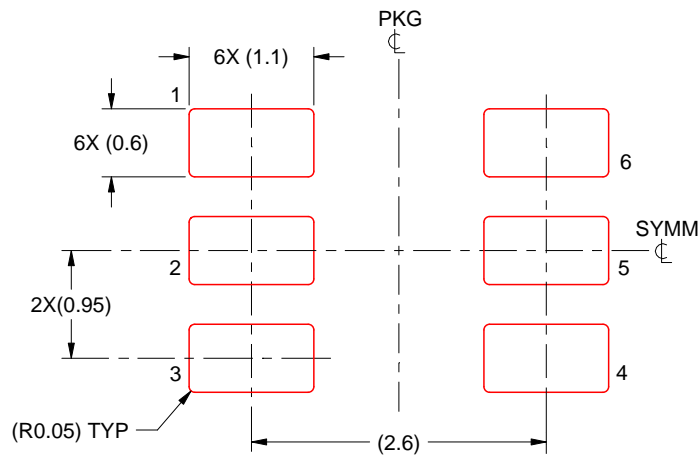

SOLDER PASTE EXAMPLE
BASED ON 0.125 mm THICK STENCIL
SCALE:15X

4214840/C 06/2021

NOTES: (continued)

8. Laser cutting apertures with trapezoidal walls and rounded corners may offer better paste release. IPC-7525 may have alternate design recommendations.
9. Board assembly site may have different recommendations for stencil design.

重要声明和免责声明

TI 提供技术和可靠性数据（包括数据表）、设计资源（包括参考设计）、应用或其他设计建议、网络工具、安全信息和其他资源，不保证没有瑕疵且不做任何明示或暗示的担保，包括但不限于对适销性、某特定用途方面的适用性或不侵犯任何第三方知识产权的暗示担保。

这些资源可供使用 TI 产品进行设计的熟练开发人员使用。您将自行承担以下全部责任：(1) 针对您的应用选择合适的 TI 产品，(2) 设计、验证并测试您的应用，(3) 确保您的应用满足相应标准以及任何其他安全、安保或其他要求。这些资源如有变更，恕不另行通知。TI 授权您仅可将这些资源用于研发本资源所述的 TI 产品的应用。严禁对这些资源进行其他复制或展示。您无权使用任何其他 TI 知识产权或任何第三方知识产权。您应全额赔偿因在这些资源的使用中对 TI 及其代表造成的任何索赔、损害、成本、损失和债务，TI 对此概不负责。

TI 提供的产品受 TI 的销售条款 (<https://www.ti.com.cn/zh-cn/legal/termsofsale.html>) 或 [ti.com.cn](https://www.ti.com.cn) 上其他适用条款/TI 产品随附的其他适用条款的约束。TI 提供这些资源并不会扩展或以其他方式更改 TI 针对 TI 产品发布的适用的担保或担保免责声明。

邮寄地址：上海市浦东新区世纪大道 1568 号中建大厦 32 楼，邮政编码：200122

Copyright © 2021 德州仪器半导体技术（上海）有限公司