

LMK1C110x 1.8V、2.5V 和 3.3V LVCMOS 时钟缓冲器系列

1 特性

- 高性能 1:2、1:3 或 1:4 LVCMOS 时钟缓冲器
- 输出偏斜极低，< 50ps
- 附加抖动极低，最大值 < 50fs
 - $V_{DD} = 3.3V$ 时，典型值为 7.5fs
 - $V_{DD} = 2.5V$ 时，典型值为 10fs
 - $V_{DD} = 1.8V$ 时，典型值为 19.2fs
- 传播延迟极低，< 3ns
- 同步输出使能
- 电源电压：3.3V、2.5V 或 1.8V
 - 在电源电压范围内输入端耐受 3.3V 电压
- $f_{max} = 250MHz$ (3.3V)
- $f_{max} = 200MHz$ (2.5V 和 1.8V)
- 工作温度范围：-40°C 至 125°C
- 采用 8 引脚 TSSOP 封装
- 采用 8 引脚 WSON 封装

2 应用

- 工厂自动化与控制
- 电信设备
- 数据中心和企业计算
- 电网基础设施
- 电机驱动器
- 医疗成像

3 说明

LMK1C110x 是德州仪器 (TI) 的一款模块化、高性能、低偏斜、通用时钟缓冲器系列器件。

整个系列采用模块化方法设计。提供三个不同的扇出选项：1:2、1:3、1:4。

该系列所有器件均互相引脚兼容，并与 CDCLVC110x 系列向后兼容，从而易于处理。

该系列所有器件均具有相同的高性能特性，如低附加抖动、低偏斜和宽工作温度范围。

LMK1C110x 具有同步输出使能控制端 (1G)，可在 1G 处于低电平时将输出切换为低电平状态。

LMK1C110x 系列可在 1.8V、2.5V 和 3.3V 电压下工作，额定工作温度范围为 -40°C 至 125°C。

器件信息(1)

器件型号	封装	封装尺寸 (标称值)
LMK1C1102	TSSOP (8)	3.00mm × 4.40mm
LMK1C1103		
LMK1C1104		
LMK1C1102	WSON (8)	2.00mm × 2.00mm
LMK1C1104		

(1) 如需了解所有可用封装，请参阅数据表末尾的可订购产品附录。

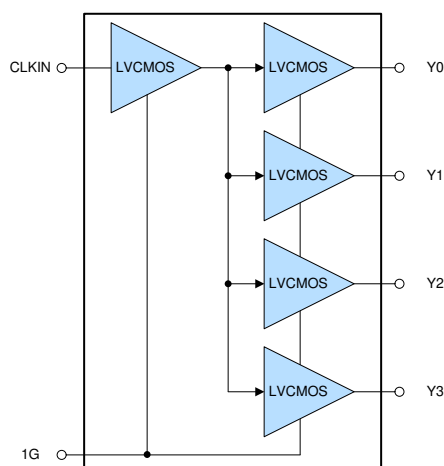

功能方框图



Table of Contents

1 特性	1	8.3 Feature Description.....	10
2 应用	1	8.4 Device Functional Modes.....	10
3 说明	1	9 Application and Implementation	11
4 Revision History	2	9.1 Application Information.....	11
5 Device Comparison	3	9.2 Typical Application.....	11
6 Pin Configuration and Functions	3	10 Power Supply Recommendations	13
7 Specifications	5	11 Layout	14
7.1 Absolute Maximum Ratings	5	11.1 Layout Guidelines.....	14
7.2 ESD Ratings	5	11.2 Layout Example.....	14
7.3 Recommended Operating Conditions	5	12 Device and Documentation Support	15
7.4 Thermal Information	5	12.1 接收文档更新通知.....	15
7.5 Electrical Characteristics	6	12.2 支持资源.....	15
7.6 Timing Requirements	7	12.3 Trademarks.....	15
7.7 Typical Characteristics.....	7	12.4 Electrostatic Discharge Caution.....	15
8 Detailed Description	10	12.5 术语表.....	15
8.1 Overview.....	10	13 Mechanical, Packaging, and Orderable Information	15
8.2 Functional Block Diagram.....	10		

4 Revision History

Changes from Revision B (June 2020) to Revision C (June 2021)	Page
• 更改了整个文档中的表、图和交叉参考的文本格式和编号格式.....	1
• 增加了 LMK1C1102/04 DQF (WSON) 封装.....	1
• Added the <i>Device Comparison</i> table.....	3
• Added pinout diagrams for the DQF (WSON) package variant of the LMK1C1102 and LMK1C1104.....	3
• Added information pertaining to the layout of LMK1C1102/04 WSON package variant.....	14
• Removed <i>Related Links</i> section.....	15

Changes from Revision A (February 2020) to Revision B (June 2020)	Page
• 向 <i>说明</i> 部分添加了扇出选项信息.....	1
• 从第一页中删除 LMK1C1104PW 引脚排列.....	1
• Added LMK1C1102 and LMK1C1103 pinout diagrams.....	3

Changes from Revision * (December 2019) to Revision A (February 2020)	Page
• 向数据表添加了 LMK1C1102 和 LMK1C1103.....	1
• Changed the <i>Power Supply Recommendations</i> section.....	13

5 Device Comparison

表 5-1. Device Comparison

DEVICE	NUMBER OF OUTPUTS	PACKAGE
LMK1C1102	2	TSSOP (8), 3.00 mm x 4.40 mm
LMK1C1103	3	
LMK1C1104	4	
LMK1C1106	6	TSSOP (14), 5.00 mm x 4.40 mm
LMK1C1108	8	TSSOP (16), 5.00 mm x 4.40 mm
LMK1C1102	2	WSON (8), 2.00 mm x 2.00 mm
LMK1C1104	4	

6 Pin Configuration and Functions



图 6-1. LMK1C1102 PW Package 8-Pin TSSOP Top View



1. The DQF (WSON) package is equivalent to the DFN package of other vendors.

图 6-2. LMK1C1102 DQF Package 8-Pin WSON Top View

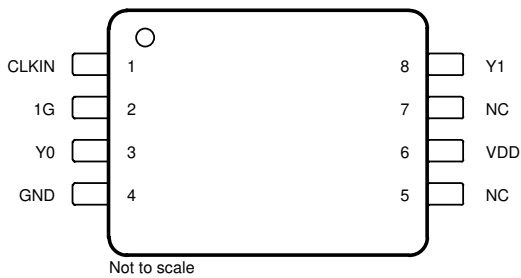
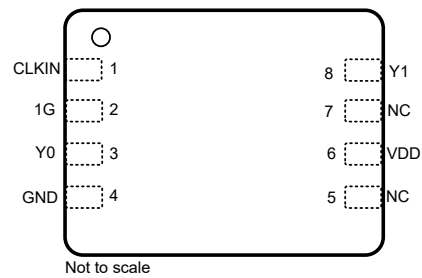

图 6-3. LMK1C1103 PW Package 8-Pin TSSOP Top View



图 6-4. LMK1C1104 PW Package 8-Pin TSSOP Top View

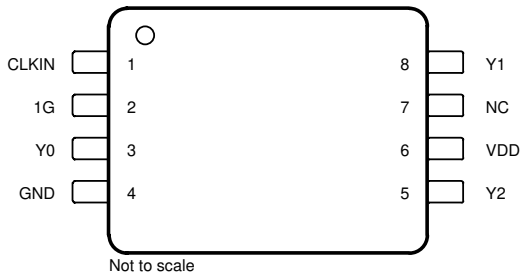

1. The DQF (WSON) package is equivalent to the DFN package of other vendors.

图 6-5. LMK1C1104 DQF Package 8-Pin WSON Top View

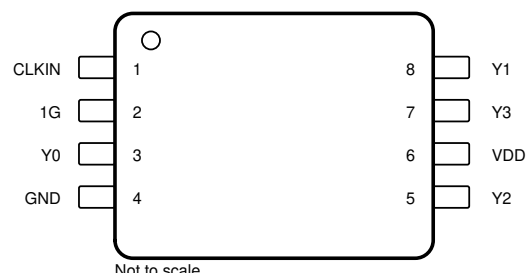
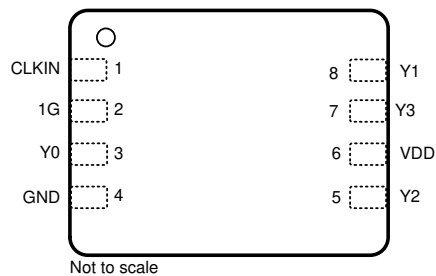
表 6-1. Pin Functions

NAME	PIN			TYPE	DESCRIPTION
	LMK1C 1102	LMK1C 1103	LMK1C 1104		
LVCMOS CLOCK INPUT					
CLKIN	1	1	1	Input	Single-ended clock input with internal 300-k Ω (typical) pulldown resistor to GND. Typically connected to a single-ended clock input.
CLOCK OUTPUT ENABLE					
1G	2	2	2	Input	Global Output Enable with internal 300-k Ω (typical) pulldown resistor to GND. Typically connected to VDD with external pullup resistor. HIGH: outputs enabled LOW: outputs disabled
LVCMOS CLOCK OUTPUT					
Y0	3	3	3	Output	LVCMOS output. Typically connected to a receiver. Unused outputs can be left floating.
Y1	8	8	8		
Y2	—	5	5		
Y3	—	—	7		
SUPPLY VOLTAGE					
VDD	6	6	6	Power	Power supply terminal. Typically connected to a 3.3-V, 2.5-V, or 1.8-V supply. The VDD pin is typically connected to an external 0.1- μ F capacitor near the pin.
GROUND					
GND	4	4	4	GND	Power supply ground.

7 Specifications

7.1 Absolute Maximum Ratings

over operating free-air temperature range (unless otherwise noted)⁽¹⁾

		MIN	MAX	UNIT
V _{DD}	Supply voltage	- 0.5	3.6	V
V _{CLKIN}	Input voltage (CLKIN)			
V _{IN}	Input voltage (1G)			
V _{Yn}	Output pins (Yn)	- 0.5	V _{DD} + 0.3	
I _{IN}	Input current	- 20	20	mA
I _O	Continuous output current	- 50	50	mA
T _{stg}	Storage temperature	- 65	150	°C

- (1) Stresses beyond those listed under *Absolute Maximum Rating* may cause permanent damage to the device. These are stress ratings only, which do not imply functional operation of the device at these or any other conditions beyond those indicated under *Recommended Operating Condition*. Exposure to absolute-maximum-rated conditions for extended periods may affect device reliability.

7.2 ESD Ratings

			VALUE	UNIT
V _(ESD)	Electrostatic discharge	Human body model (HBM), per ANSI/ESDA/ JEDEC JS-001, all pins ⁽¹⁾	±9000	V
		Charged device model (CDM), per JEDEC specification JESD22-C101, all pins ⁽²⁾	±1500	

- (1) JEDEC document JEP155 states that 500-V HBM allows safe manufacturing with a standard ESD control process.
(2) JEDEC document JEP157 states that 250-V CDM allows safe manufacturing with a standard ESD control process.

7.3 Recommended Operating Conditions

over operating free-air temperature range (unless otherwise noted)

			MIN	NOM	MAX	UNIT
V _{DD}	Core supply voltage	3.3-V supply	3.135	3.3	3.465	V
		2.5-V supply	2.375	2.5	2.625	
		1.8-V supply	1.71	1.8	1.89	
T _A	Operating free-air temperature		- 40		125	°C
T _J	Operating junction temperature		- 40		150	°C

7.4 Thermal Information

THERMAL METRIC ⁽¹⁾		LMK1C1104		UNIT
		DQF (WSON)	PW (TSSOP)	
		8 PINS	8 PINS	
R _{qJA}	Junction-to-ambient thermal resistance	163	181.9	°C/W
R _{qJC(top)}	Junction-to-case (top) thermal resistance	105.7	76.6	°C/W
R _{qJB}	Junction-to-board thermal resistance	84.2	111.6	°C/W
Y _{JT}	Junction-to-top characterization parameter	16.7	16	°C/W
Y _{JB}	Junction-to-board characterization parameter	83.9	110.1	°C/W

- (1) For more information about traditional and new thermal metrics, see the [Semiconductor and IC Package Thermal Metrics](#) application report.

7.5 Electrical Characteristics

VDD = 3.3 V ± 5%, -40°C ≤ TA ≤ 125°C. Typical values are at VDD = 3.3 V, 25°C (unless otherwise noted)

PARAMETER		TEST CONDITIONS	MIN	TYP	MAX	UNIT	
CURRENT CONSUMPTION							
I _{DD}	Core supply current, static	All-outputs disabled, f _{IN} = 0 V		25	45	μA	
I _{DD}	Core supply current	All-outputs disabled, f _{IN} = 100 MHz		8	15	mA	
		All-outputs active, f _{IN} = 100 MHz, C _L = 5pF, V _{DD} = 1.8 V		14	20		
		All-outputs active, f _{IN} = 100 MHz, C _L = 5pF, V _{DD} = 2.5 V		21	30		
		All-outputs active, f _{IN} = 100 MHz, C _L = 5pF, V _{DD} = 3.3 V		33	40		
CLOCK INPUT							
f _{IN_SE}	Input frequency	V _{DD} = 3.3 V	DC		250	MHz	
		V _{DD} = 2.5 V and 1.8 V	DC		200		
V _{IH}	Input high voltage		0.7 x V _{DD}			V	
V _{IL}	Input low voltage				0.3 x V _{DD}		
dV _{IN} /dt	Input slew rate	20% - 80% of input swing	0.1			V/ns	
I _{IN_LEAK}	Input leakage current		- 50		50	uA	
C _{IN_SE}	Input capacitance	at 25°C			7	pF	
CLOCK OUTPUT FOR ALL V_{DD} LEVELS							
f _{OUT}	Output frequency	V _{DD} = 3.3 V			250	MHz	
		V _{DD} = 2.5 V and 1.8 V			200		
ODC	Output duty cycle	With 50% duty cycle input (for all VDD)	45		55	%	
t _{START}	Start-up time before output is active	See (1)			3	ms	
t _{1G_ON}	Output enable time	See (2)			5	cycles	
t _{1G_OFF}	Output disable time	See (3)			5	cycles	
CLOCK OUTPUT FOR V_{DD} = 3.3 V ± 5%							
V _{OH}	Output high voltage	I _{OH} = 1 mA	2.8			V	
V _{OL}	Output low voltage	I _{OL} = 1 mA			0.2		
t _{RISE-FALL}	Output rise and fall time	20/80%, C _L = 5 pF, f _{IN} = 156.25 MHz			0.35	0.7	ns
t _{OUTPUT-SKEW}	Output-output skew	See (4)			25	50	ps
t _{PART-SKEW}	Part-to-part skew					450	
t _{PROP-DELAY}	Propagation delay	See (5)			1.5	2	ns
t _{JITTER-ADD}	Additive Jitter	f _{IN} = 156.25 MHz, Input slew rate = 2 V/ns, Integration range = 12 kHz - 20 MHz			8	20	fs, RMS
R _{OUT}	Output impedance				50		Ω
CLOCK OUTPUT FOR V_{DD} = 2.5 V ± 5%							
V _{OH}	Output high voltage	I _{OH} = 1 mA	0.8 x V _{DD}			V	
V _{OL}	Output low voltage	I _{OL} = 1 mA			0.2 x V _{DD}		
t _{RISE-FALL}	Output rise and fall time	20/80%, C _L = 5 pF, f _{IN} = 156.25 MHz			0.33	0.8	ns
t _{OUTPUT-SKEW}	Output-output skew	See (4)			50		ps
t _{PART-SKEW}	Part-to-part skew				400		
t _{PROP-DELAY}	Propagation delay	See (5)			1.5	2.5	ns
t _{JITTER-ADD}	Additive Jitter	f _{IN} = 156.25 MHz, Input slew rate = 2 V/ns, Integration range = 12 kHz - 20 MHz			11	27	fs, RMS
R _{OUT}	Output impedance				52.5		Ω

VDD = 3.3 V ± 5 %, - 40°C ≤ TA ≤ 125°C. Typical values are at VDD = 3.3 V, 25°C (unless otherwise noted)

PARAMETER	TEST CONDITIONS	MIN	TYP	MAX	UNIT	
CLOCK OUTPUT FOR V _{DD} = 1.8 V ± 5%						
V _{OH}	Output high voltage	I _{OH} = 1 mA		0.8 x V _{DD}	V	
V _{OL}	Output low voltage	I _{OL} = 1 mA		0.2 x V _{DD}		
t _{RISE-FALL}	Output rise and fall time	20/80%, C _L = 5 pF, f _{IN} = 156.25 MHz		0.38	1	ns
t _{OUTPUT-SKEW}	Output-output skew	See (4)			50	ps
t _{PART-SKEW}	Part-to-part skew				900	ps
t _{PROP-DELAY}	Propagation delay	See (5)		1.5	3	ns
t _{JITTER-ADD}	Additive Jitter	f _{IN} = 156.25 MHz, Input slew rate = 2 V/ns, Integration range = 12 kHz - 20 MHz		17.5	50	fs, RMS
R _{OUT}	Output impedance			60		Ω
GENERAL PURPOSE INPUT (1G)						
V _{IH}	High-level input voltage			0.75 x V _{DD}	V	
V _{IL}	Low-level input voltage			0.25 x V _{DD}		
I _{IH}	Input high-level current	V _{IH} = V _{DD_REF}		- 50	50	μA
I _{IL}	Input low-level current	V _{IL} = GND		- 50	50	

- (1) Measured from VDD stable to output active, when 1G = HIGH.
- (2) Measured from 1G rising edge crossing VIH to first rising edge of Yn.
- (3) Measured from 1G falling edge crossing VIL to last falling edge of Yn.
- (4) Measured from rising edge of any Yn output to any other Ym output.
- (5) Measured from rising edge of CLKIN to any Yn output.

7.6 Timing Requirements

VDD = 3.3 V ± 5 %, - 40°C ≤ TA ≤ 125°C

		MIN	NOM	MAX	UNIT
POWER SUPPLY					
V/t _{RAMP}	V _{DD} ramp rate	0.1		50	V/ms

7.7 Typical Characteristics



图 7-1. Device Power Consumption vs. Clock Frequency (Load 5 pF)

Parameter Measurement Information



图 8-1. Test Load Circuit

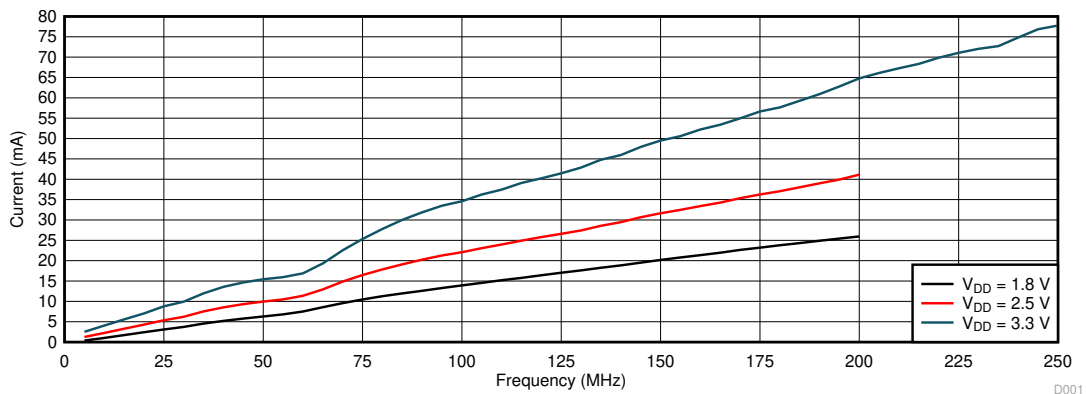

图 8-2. Application Load With 50- Ω Termination

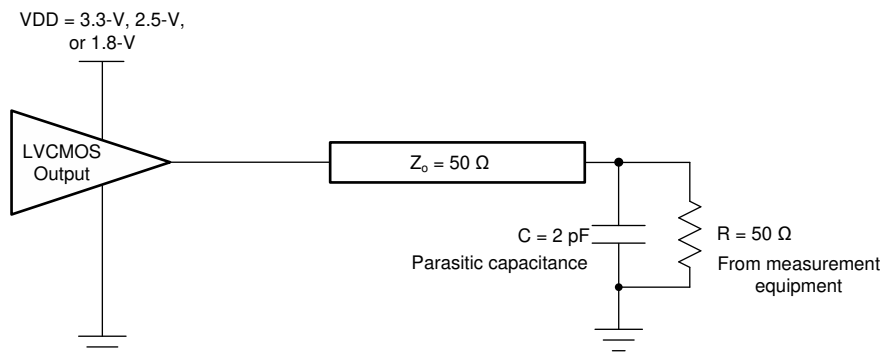

图 8-3. Application Load With Termination

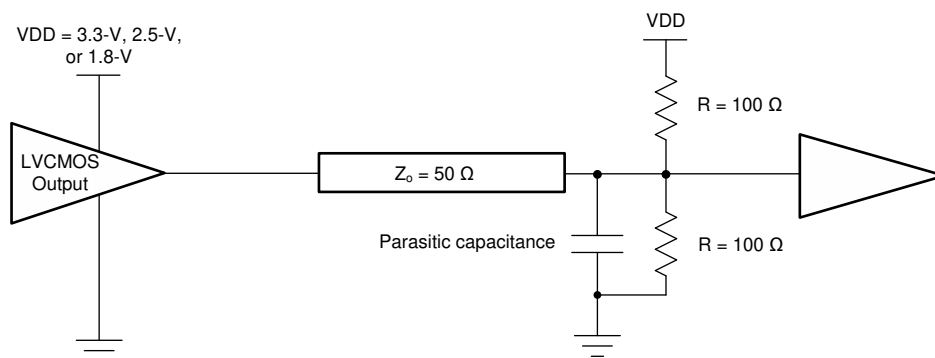

图 8-4. t_{1G_ON} Output Enable Time

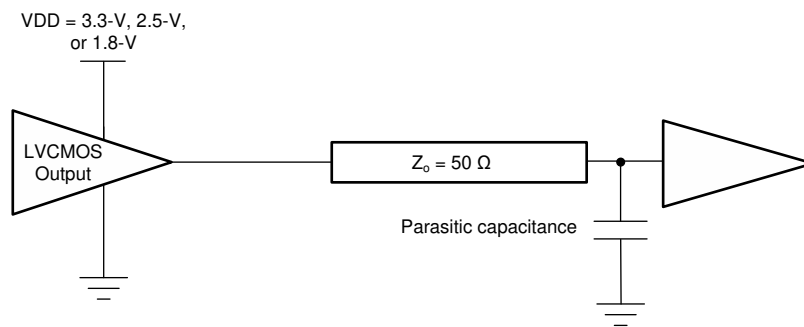

图 8-5. t_{1G_OFF} Output Disable Time

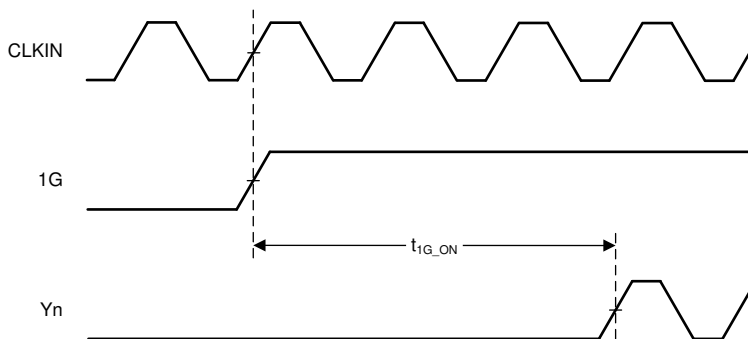

图 8-6. Propagation Delay $t_{PROP-DELAY}$ and Output Skew $t_{OUTPUT-SKEW}$

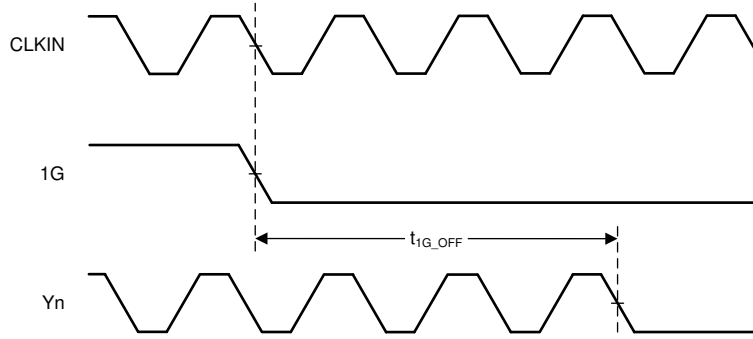

图 8-7. Rise and Fall Time $t_{RISE-FALL}$

8 Detailed Description

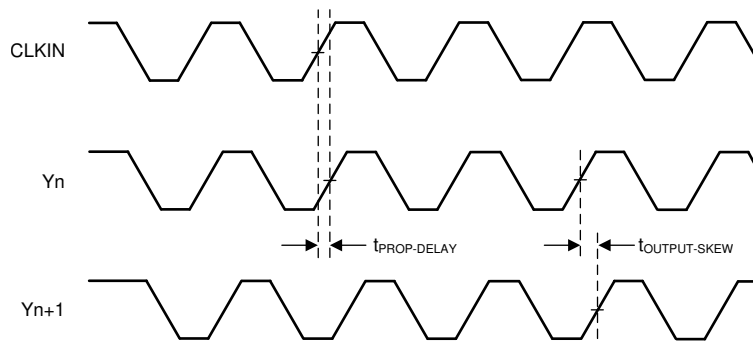
8.1 Overview

The LMK1C110x family of devices is part of a low-jitter and low-skew LVCMOS fan-out buffer solution. For best signal integrity, it is important to match the characteristic impedance of the LMK1C110x's output driver with that of the transmission line.

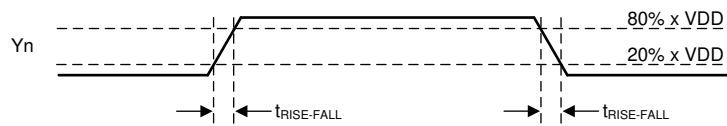
8.2 Functional Block Diagram

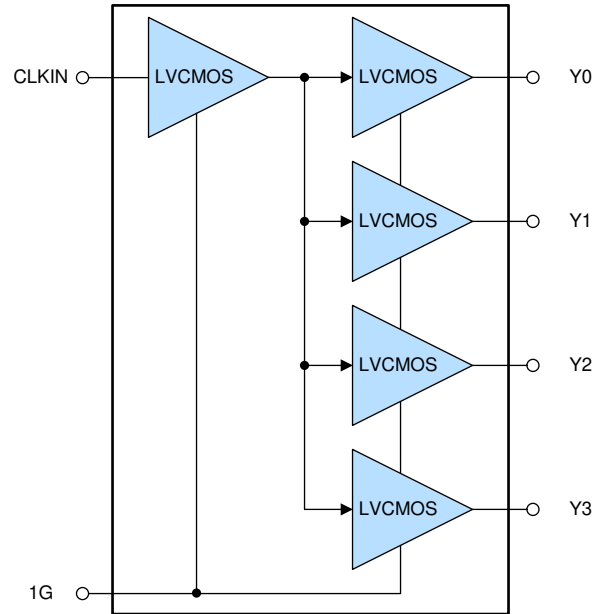

8.3 Feature Description

The outputs of the LMK1C110x can be disabled by driving the synchronous output enable pin (1G) low. Unused output can be left floating to reduce overall system component cost. Supply and ground pins must be connected to V_{DD} and GND, respectively.

8.4 Device Functional Modes

The LMK1C110x operates from 1.8-V, 2.5-V, or 3.3-V supplies. 表 8-1 shows the output logics of the LMK1C110x.

表 8-1. Output Logic Table

INPUTS		OUTPUTS
CLKIN	1G	Yn
X	L	L
L	H	L
H	H	H

9 Application and Implementation

Note

以下应用部分中的信息不属于 TI 器件规格的范围，TI 不担保其准确性和完整性。TI 的客户应负责确定器件是否适用于其应用。客户应验证并测试其设计，以确保系统功能。

9.1 Application Information

The LMK1C110x family is a low additive jitter LVCMOS buffer solution that can operate up to 250-MHz at $V_{DD} = 3.3\text{ V}$ and 200 MHz at $V_{DD} = 2.5\text{ V}$ to 1.8 V. Low output skew as well as the ability for synchronous output enable is featured to simultaneously enable or disable buffered clock outputs as necessary in the application.

9.2 Typical Application



图 9-1. System Configuration Example

9.2.1 Design Requirements

The LMK1C110x shown in 图 9-1 is configured to fan out a 100-MHz signal from a local LVCMOS oscillator. The CPU is configured to control the output state through 1G.

The configuration example is driving three LVCMOS receivers in a backplane application with the following properties:

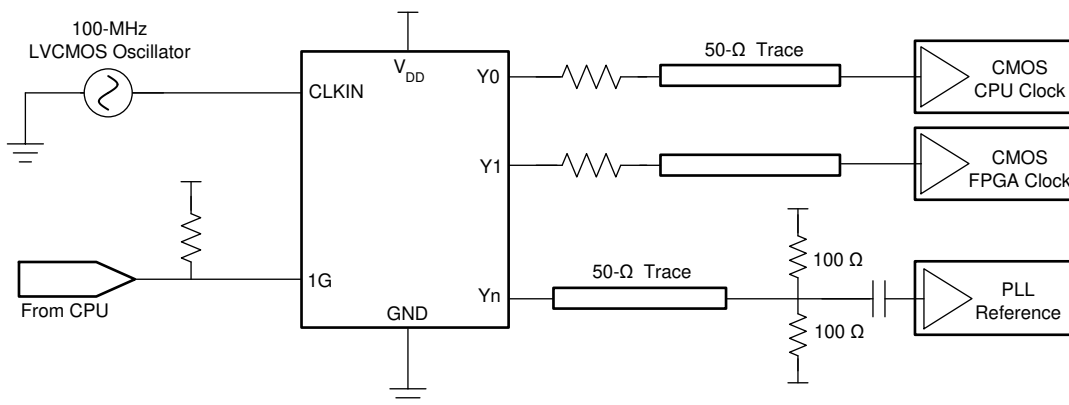
- The CPU clock can accept a full swing DC-coupled LVCMOS signal. A series resistor is placed near the LMK1C110x to closely match the characteristic impedance of the trace to minimize reflections.
- The FPGA clock is similarly DC-coupled with an appropriate series resistor placed near the LMK1C110x.
- The PLL in this example can accept a lower amplitude signal, so a Thevenin's equivalent termination is used. The PLL receiver features internal biasing, so AC coupling can be used when common-mode voltage is mismatched.

9.2.2 Detailed Design Procedure

Unused outputs can be left floating. See the [Power Supply Recommendations](#) section for recommended filtering techniques.

9.2.3 Application Curves

The low additive jitter of the LMK1C110x is shown in 图 9-2.

图 9-3 shows the low-noise 156.25-MHz reference source with 25.6-fs RMS jitter driving the LMK1C110x, resulting in 26.7-fs RMS jitter when integrated from 12 kHz to 20 MHz at 3.3-V supply. The resultant additive jitter measured is a low 7.6-fs RMS for this configuration.

LMK1C1102, LMK1C1103, LMK1C1104

ZHCSKK6C – DECEMBER 2019 – REVISED JUNE 2021

图 9-4 shows the low-noise 156.25-MHz reference source with 25.6-fs RMS jitter driving the LMK1C110x, resulting in 27.5-fs RMS jitter when integrated from 12 kHz to 20 MHz at 2.5-V supply. The resultant additive jitter measured is a low 10-fs RMS for this configuration.

图 9-5 shows the low-noise 156.25-MHz reference source with 25.6-fs RMS jitter driving the LMK1C110x, resulting in 32-fs RMS jitter when integrated from 12 kHz to 20 MHz at 1.8-V supply. The resultant additive jitter measured is a low 19.2-fs RMS for this configuration.



图 9-2. LMK1C110x Reference Phase Noise 25.6-fs (12 kHz to 20 MHz)



图 9-3. LMK1C110x 3.3-V Output Phase Noise 26.7-fs (12 kHz to 20 MHz)

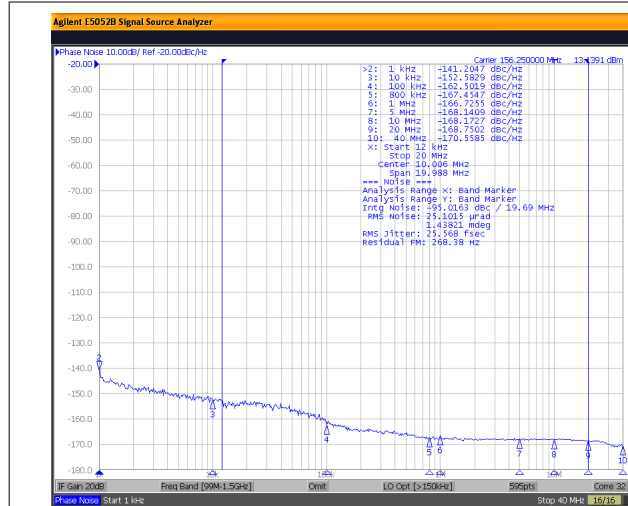

图 9-4. LMK1C110x 2.5-V Output Phase Noise 27.5-fs (12 kHz to 20 MHz)

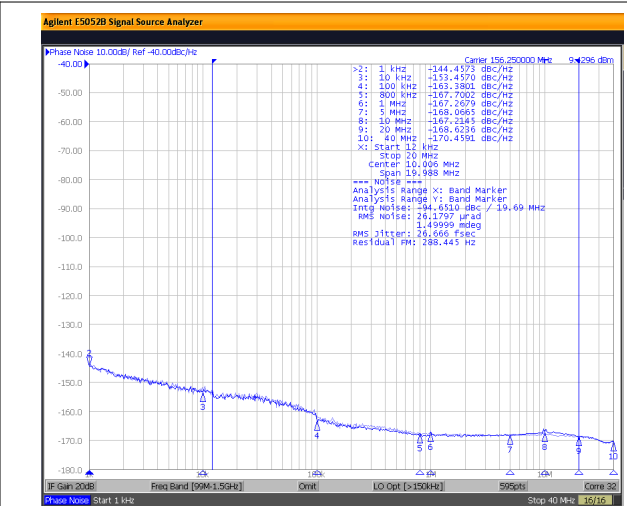

图 9-5. LMK1C110x 1.8-V Output Phase Noise 32-fs (12 kHz to 20 MHz)

10 Power Supply Recommendations

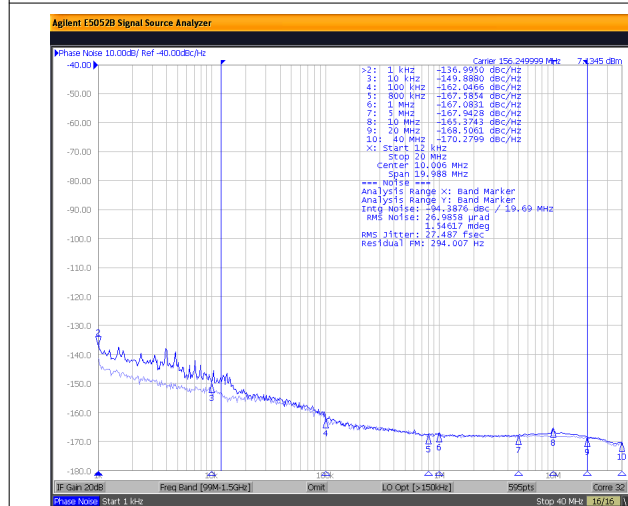
High-performance clock buffers can be sensitive to noise on the power supply, which may dramatically increase the additive jitter of the buffer. Thus, it is essential to manage any excessive noise from the system power supply, especially for applications where the jitter and phase noise performance is critical.

Filter capacitors are used to eliminate the low-frequency noise from the power supply, where the bypass capacitors provide the very low impedance path for high-frequency noise and guard the power supply system against induced fluctuations. These bypass capacitors also provide instantaneous current surges as required by the device and should have low equivalent series resistance (ESR). To properly bypass the supply, the decoupling capacitors must be placed very close to the power-supply terminals, be connected directly to the ground plane, and laid out with short loops to minimize inductance. TI recommends adding as many high-frequency (for example, 0.1 μF) bypass capacitors, as there are supply terminals in the package. TI recommends, but does not require, inserting a ferrite bead between the board power supply and the chip power supply that isolates the high-frequency switching noises generated by the clock buffer; these beads prevent the switching noise from leaking into the board supply. It is imperative to choose an appropriate ferrite bead with very low DC resistance to provide adequate isolation between the board supply and the chip supply, as well as to maintain a voltage at the supply terminals that is greater than the minimum voltage required for proper operation.

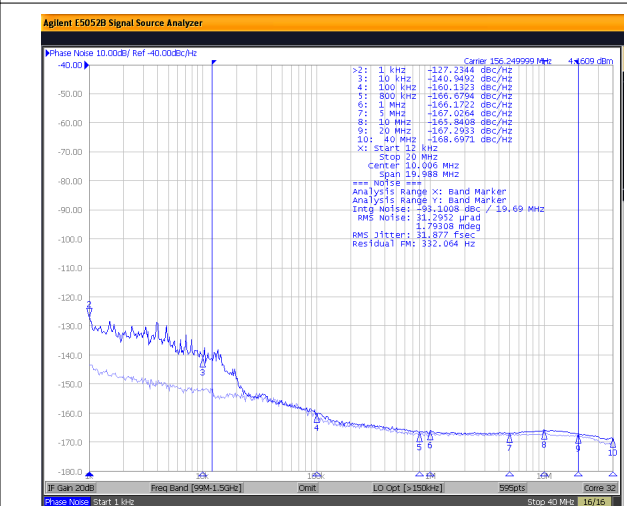
Figure 10-1 shows this recommended power supply decoupling method.

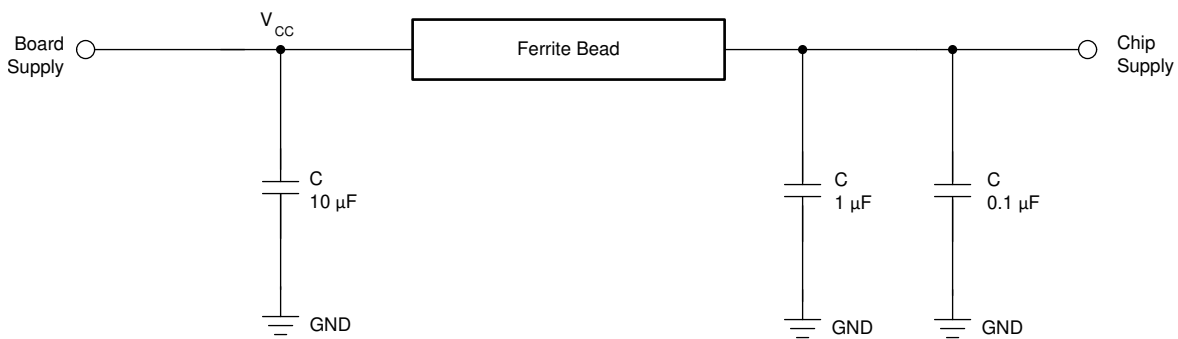

Figure 10-1. Power Supply Decoupling

11 Layout

11.1 Layout Guidelines

图 11-1 shows a conceptual layout detailing recommended placement of power supply bypass capacitors. For component side mounting, use 0402 body size capacitors to facilitate signal routing. Keep the connections between the bypass capacitors and the power supply on the device as short as possible. Ground the other side of the capacitor using a low-impedance connection to the ground plane.

图 11-2 provides a visual representation of the WSON device; it can be seen from the figure that similar to a DFN package, WSON doesn't have any leads.

11.2 Layout Example



图 11-1. PCB Conceptual Layout



图 11-2. Layout illustration for 8-pin WSON device

12 Device and Documentation Support

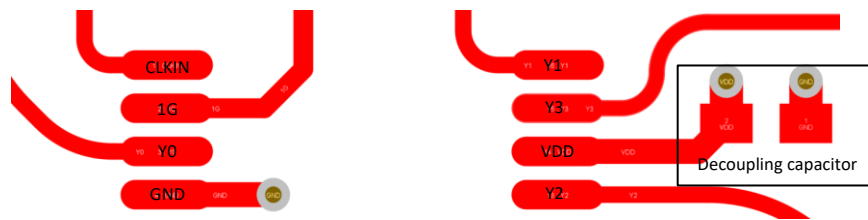
12.1 接收文档更新通知

要接收文档更新通知，请导航至 ti.com 上的器件产品文件夹。点击 [订阅更新](#) 进行注册，即可每周接收产品信息更改摘要。有关更改的详细信息，请查看任何已修订文档中包含的修订历史记录。

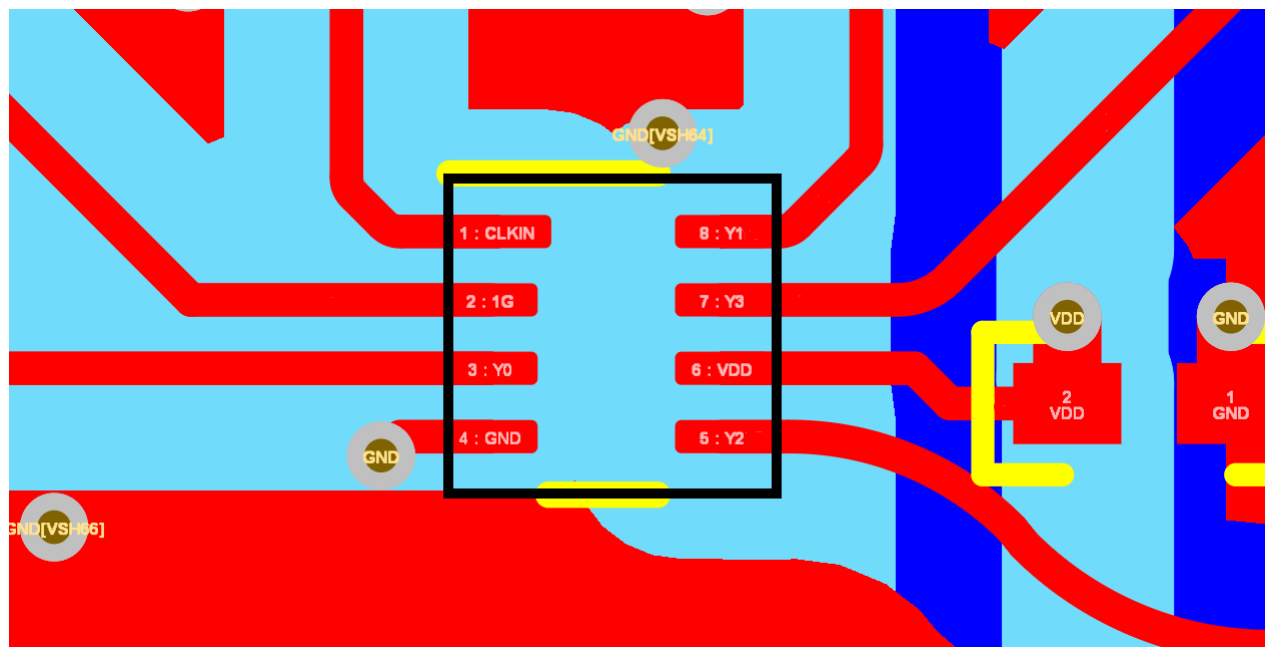
12.2 支持资源

[TI E2E™ 支持论坛](#) 是工程师的重要参考资料，可直接从专家获得快速、经过验证的解答和设计帮助。搜索现有解答或提出自己的问题可获得所需的快速设计帮助。

链接的内容由各个贡献者“按原样”提供。这些内容并不构成 TI 技术规范，并且不一定反映 TI 的观点；请参阅 TI 的《[使用条款](#)》。

12.3 Trademarks

TI E2E™ is a trademark of Texas Instruments.

所有商标均为其各自所有者的财产。

12.4 Electrostatic Discharge Caution



This integrated circuit can be damaged by ESD. Texas Instruments recommends that all integrated circuits be handled with appropriate precautions. Failure to observe proper handling and installation procedures can cause damage.

ESD damage can range from subtle performance degradation to complete device failure. Precision integrated circuits may be more susceptible to damage because very small parametric changes could cause the device not to meet its published specifications.

12.5 术语表

[TI 术语表](#) 本术语表列出并解释了术语、首字母缩略词和定义。

13 Mechanical, Packaging, and Orderable Information

The following pages include mechanical, packaging, and orderable information. This information is the most current data available for the designated devices. This data is subject to change without notice and revision of this document. For browser-based versions of this data sheet, refer to the left-hand navigation.

重要声明和免责声明

TI 提供技术和可靠性数据 (包括数据表)、设计资源 (包括参考设计)、应用或其他设计建议、网络工具、安全信息和其他资源, 不保证没有瑕疵且不做任何明示或暗示的担保, 包括但不限于对适销性、某特定用途方面的适用性或不侵犯任何第三方知识产权的暗示担保。

这些资源可供使用 TI 产品进行设计的熟练开发人员使用。您将自行承担以下全部责任: (1) 针对您的应用选择合适的 TI 产品, (2) 设计、验证并测试您的应用, (3) 确保您的应用满足相应标准以及任何其他安全、安保或其他要求。这些资源如有变更, 恕不另行通知。TI 授权您仅可将这些资源用于研发本资源所述的 TI 产品的应用。严禁对这些资源进行其他复制或展示。您无权使用任何其他 TI 知识产权或任何第三方知识产权。您应全额赔偿因在这些资源的使用中对 TI 及其代表造成的任何索赔、损害、成本、损失和债务, TI 对此概不负责。

TI 提供的产品受 TI 的销售条款 (<https://www.ti.com/legal/termsofsale.html>) 或 [ti.com](https://www.ti.com) 上其他适用条款/TI 产品随附的其他适用条款的约束。TI 提供这些资源并不会扩展或以其他方式更改 TI 针对 TI 产品发布的适用的担保或担保免责声明。

邮寄地址: Texas Instruments, Post Office Box 655303, Dallas, Texas 75265
Copyright © 2021, 德州仪器 (TI) 公司

PACKAGING INFORMATION

Orderable Device	Status (1)	Package Type	Package Drawing	Pins	Package Qty	Eco Plan (2)	Lead finish/ Ball material (6)	MSL Peak Temp (3)	Op Temp (°C)	Device Marking (4/5)	Samples
LMK1C1102DQFR	ACTIVE	WSON	DQF	8	3000	RoHS & Green	NIPDAUAG	Level-1-260C-UNLIM	-40 to 125	L1C2	Samples
LMK1C1102DQFT	ACTIVE	WSON	DQF	8	250	RoHS & Green	NIPDAUAG	Level-1-260C-UNLIM	-40 to 125	L1C2	Samples
LMK1C1102PWR	ACTIVE	TSSOP	PW	8	2000	RoHS & Green	NIPDAU	Level-1-260C-UNLIM	-40 to 125	LMK1C2	Samples
LMK1C1103PWR	ACTIVE	TSSOP	PW	8	2000	RoHS & Green	NIPDAU	Level-1-260C-UNLIM	-40 to 125	LMK1C3	Samples
LMK1C1104DQFR	ACTIVE	WSON	DQF	8	3000	RoHS & Green	NIPDAUAG	Level-1-260C-UNLIM	-40 to 125	L1C4	Samples
LMK1C1104DQFT	ACTIVE	WSON	DQF	8	250	RoHS & Green	NIPDAUAG	Level-1-260C-UNLIM	-40 to 125	L1C4	Samples
LMK1C1104PWR	ACTIVE	TSSOP	PW	8	2000	RoHS & Green	NIPDAU	Level-1-260C-UNLIM	-40 to 125	LMK1C4	Samples

(1) The marketing status values are defined as follows:

ACTIVE: Product device recommended for new designs.

LIFEBUY: TI has announced that the device will be discontinued, and a lifetime-buy period is in effect.

NRND: Not recommended for new designs. Device is in production to support existing customers, but TI does not recommend using this part in a new design.

PREVIEW: Device has been announced but is not in production. Samples may or may not be available.

OBSOLETE: TI has discontinued the production of the device.

(2) **RoHS:** TI defines "RoHS" to mean semiconductor products that are compliant with the current EU RoHS requirements for all 10 RoHS substances, including the requirement that RoHS substance do not exceed 0.1% by weight in homogeneous materials. Where designed to be soldered at high temperatures, "RoHS" products are suitable for use in specified lead-free processes. TI may reference these types of products as "Pb-Free".

RoHS Exempt: TI defines "RoHS Exempt" to mean products that contain lead but are compliant with EU RoHS pursuant to a specific EU RoHS exemption.

Green: TI defines "Green" to mean the content of Chlorine (Cl) and Bromine (Br) based flame retardants meet JS709B low halogen requirements of <=1000ppm threshold. Antimony trioxide based flame retardants must also meet the <=1000ppm threshold requirement.

(3) MSL, Peak Temp. - The Moisture Sensitivity Level rating according to the JEDEC industry standard classifications, and peak solder temperature.

(4) There may be additional marking, which relates to the logo, the lot trace code information, or the environmental category on the device.

(5) Multiple Device Markings will be inside parentheses. Only one Device Marking contained in parentheses and separated by a "~" will appear on a device. If a line is indented then it is a continuation of the previous line and the two combined represent the entire Device Marking for that device.

⁽⁶⁾ Lead finish/Ball material - Orderable Devices may have multiple material finish options. Finish options are separated by a vertical ruled line. Lead finish/Ball material values may wrap to two lines if the finish value exceeds the maximum column width.

Important Information and Disclaimer:The information provided on this page represents TI's knowledge and belief as of the date that it is provided. TI bases its knowledge and belief on information provided by third parties, and makes no representation or warranty as to the accuracy of such information. Efforts are underway to better integrate information from third parties. TI has taken and continues to take reasonable steps to provide representative and accurate information but may not have conducted destructive testing or chemical analysis on incoming materials and chemicals. TI and TI suppliers consider certain information to be proprietary, and thus CAS numbers and other limited information may not be available for release.

In no event shall TI's liability arising out of such information exceed the total purchase price of the TI part(s) at issue in this document sold by TI to Customer on an annual basis.

TAPE AND REEL INFORMATION

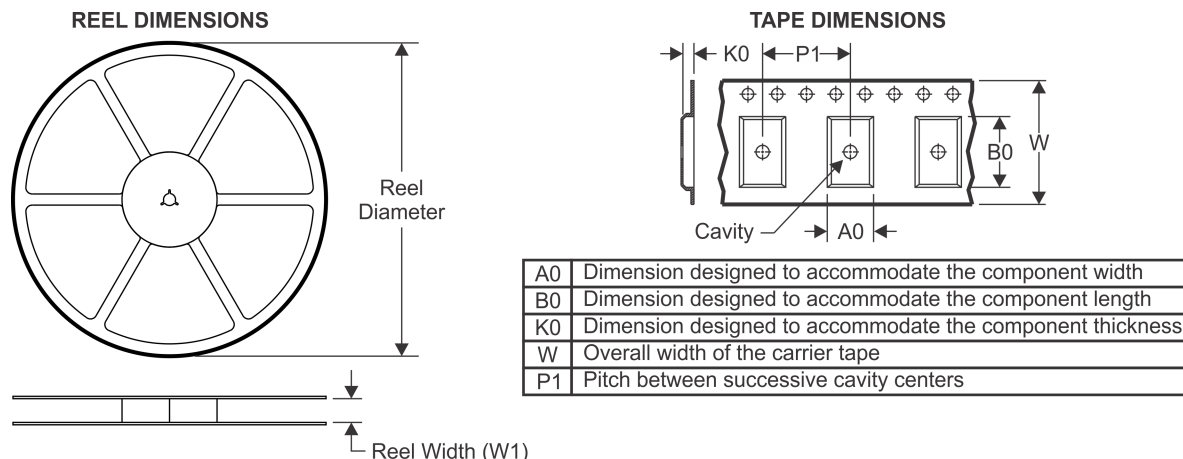

QUADRANT ASSIGNMENTS FOR PIN 1 ORIENTATION IN TAPE



*All dimensions are nominal

Device	Package Type	Package Drawing	Pins	SPQ	Reel Diameter (mm)	Reel Width W1 (mm)	A0 (mm)	B0 (mm)	K0 (mm)	P1 (mm)	W (mm)	Pin1 Quadrant
LMK1C1102DQFR	WSOP	DQF	8	3000	178.0	8.4	2.25	2.25	1.0	4.0	8.0	Q2
LMK1C1102DQFT	WSOP	DQF	8	250	178.0	8.4	2.25	2.25	1.0	4.0	8.0	Q2
LMK1C1102PWR	TSSOP	PW	8	2000	330.0	12.4	7.0	3.6	1.6	8.0	12.0	Q1
LMK1C1103PWR	TSSOP	PW	8	2000	330.0	12.4	7.0	3.6	1.6	8.0	12.0	Q1
LMK1C1104DQFR	WSOP	DQF	8	3000	178.0	8.4	2.25	2.25	1.0	4.0	8.0	Q2
LMK1C1104DQFT	WSOP	DQF	8	250	178.0	8.4	2.25	2.25	1.0	4.0	8.0	Q2
LMK1C1104PWR	TSSOP	PW	8	2000	330.0	12.4	7.0	3.6	1.6	8.0	12.0	Q1

TAPE AND REEL BOX DIMENSIONS

*All dimensions are nominal

Device	Package Type	Package Drawing	Pins	SPQ	Length (mm)	Width (mm)	Height (mm)
LMK1C1102DQFR	WSON	DQF	8	3000	205.0	200.0	33.0
LMK1C1102DQFT	WSON	DQF	8	250	205.0	200.0	33.0
LMK1C1102PWR	TSSOP	PW	8	2000	853.0	449.0	35.0
LMK1C1103PWR	TSSOP	PW	8	2000	853.0	449.0	35.0
LMK1C1104DQFR	WSON	DQF	8	3000	205.0	200.0	33.0
LMK1C1104DQFT	WSON	DQF	8	250	205.0	200.0	33.0
LMK1C1104PWR	TSSOP	PW	8	2000	853.0	449.0	35.0

PW0008A



PACKAGE OUTLINE
TSSOP - 1.2 mm max height

SMALL OUTLINE PACKAGE

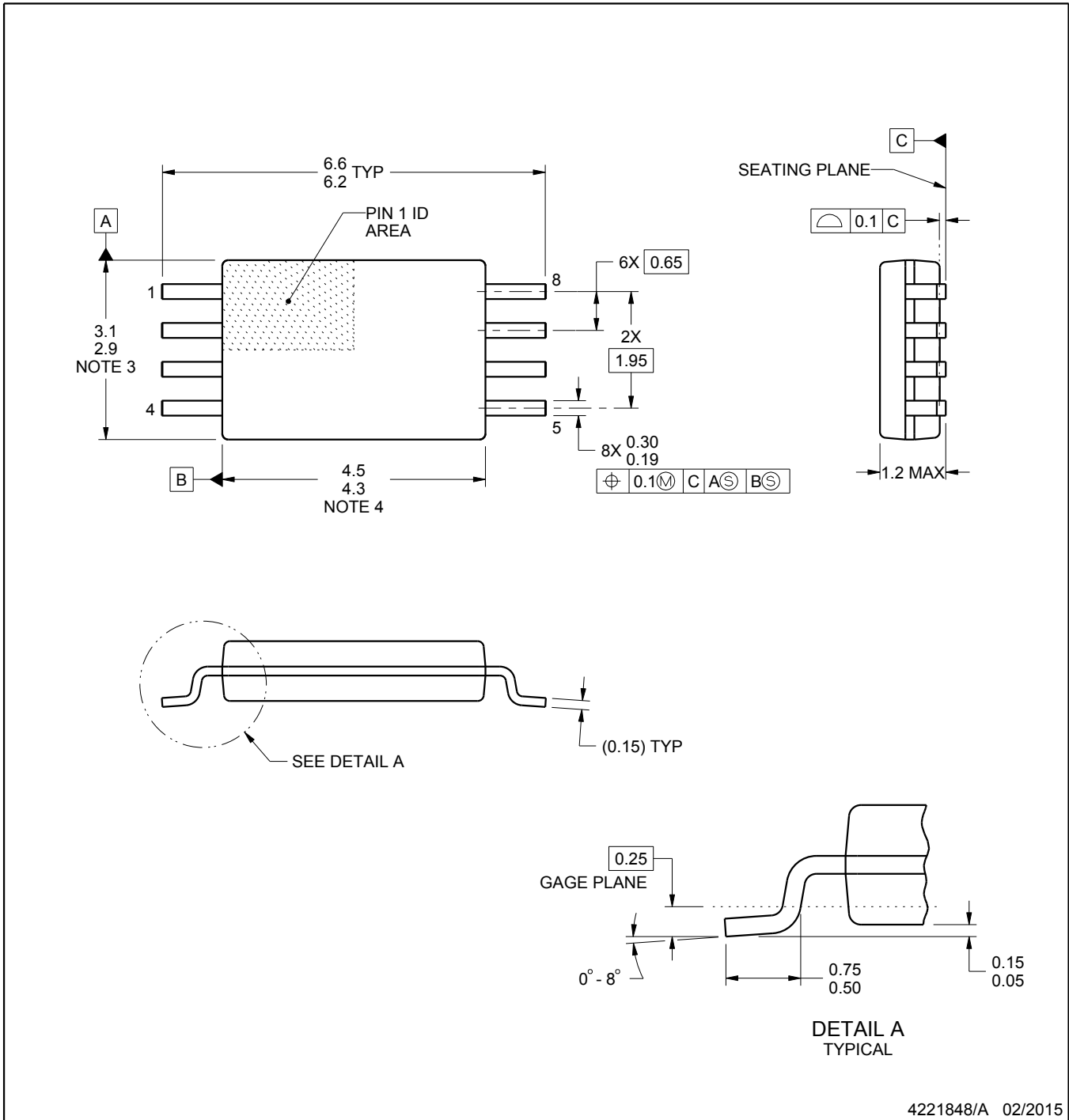

4221848/A 02/2015

NOTES:

1. All linear dimensions are in millimeters. Any dimensions in parenthesis are for reference only. Dimensioning and tolerancing per ASME Y14.5M.
2. This drawing is subject to change without notice.
3. This dimension does not include mold flash, protrusions, or gate burrs. Mold flash, protrusions, or gate burrs shall not exceed 0.15 mm per side.
4. This dimension does not include interlead flash. Interlead flash shall not exceed 0.25 mm per side.
5. Reference JEDEC registration MO-153, variation AA.

EXAMPLE BOARD LAYOUT

PW0008A

TSSOP - 1.2 mm max height

SMALL OUTLINE PACKAGE



LAND PATTERN EXAMPLE
SCALE:10X



SOLDER MASK DETAILS
NOT TO SCALE

4221848/A 02/2015

NOTES: (continued)

- 6. Publication IPC-7351 may have alternate designs.
- 7. Solder mask tolerances between and around signal pads can vary based on board fabrication site.

EXAMPLE STENCIL DESIGN

PW0008A

TSSOP - 1.2 mm max height

SMALL OUTLINE PACKAGE



SOLDER PASTE EXAMPLE
BASED ON 0.125 mm THICK STENCIL
SCALE:10X

4221848/A 02/2015

NOTES: (continued)

8. Laser cutting apertures with trapezoidal walls and rounded corners may offer better paste release. IPC-7525 may have alternate design recommendations.
9. Board assembly site may have different recommendations for stencil design.

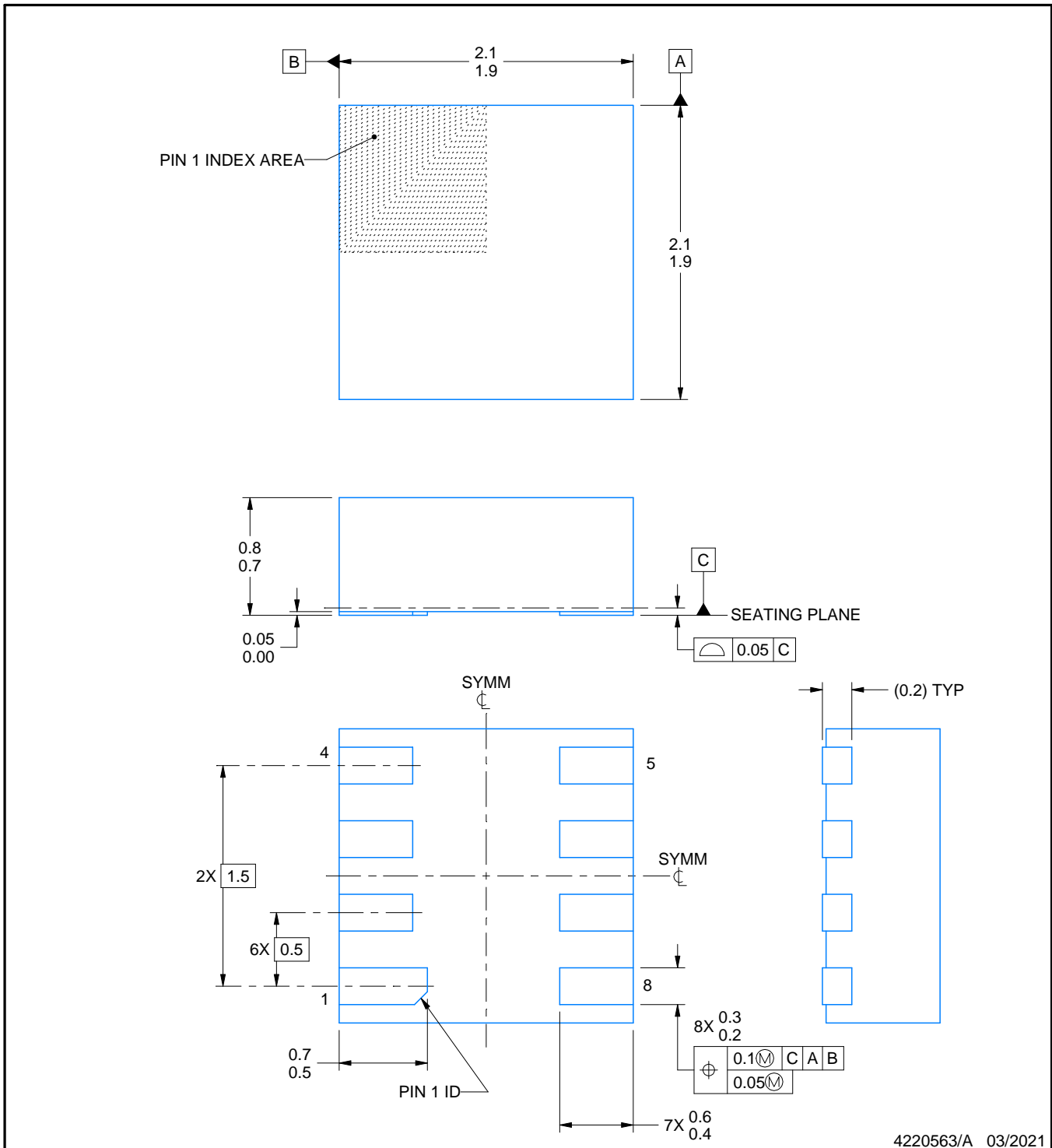
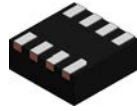

NOTES:

1. All linear dimensions are in millimeters. Any dimensions in parenthesis are for reference only. Dimensioning and tolerancing per ASME Y14.5M.
2. This drawing is subject to change without notice.

EXAMPLE BOARD LAYOUT

DQF0008A

WSON - 0.8 mm max height

PLASTIC SMALL OUTLINE - NO LEAD

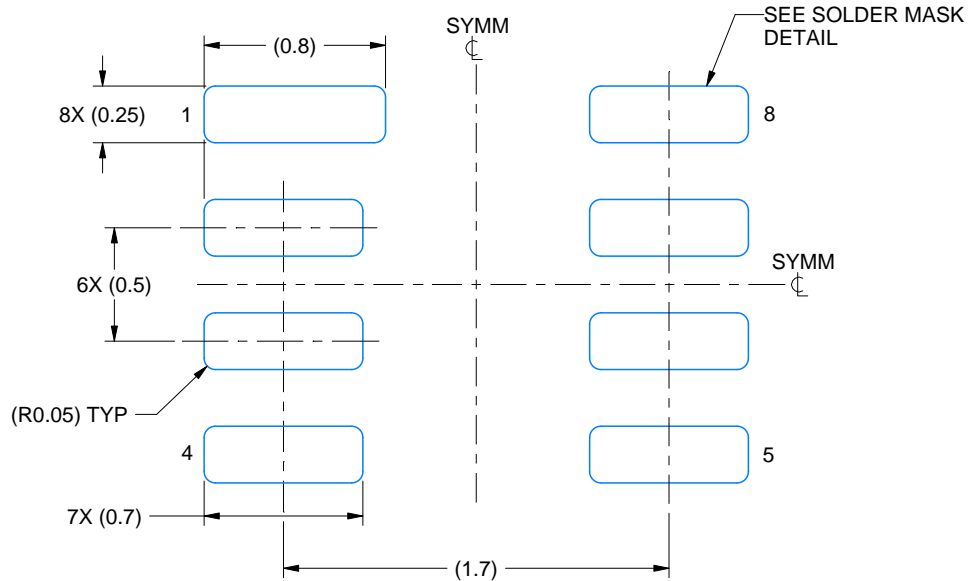

LAND PATTERN EXAMPLE
EXPOSED METAL SHOWN
SCALE: 30X

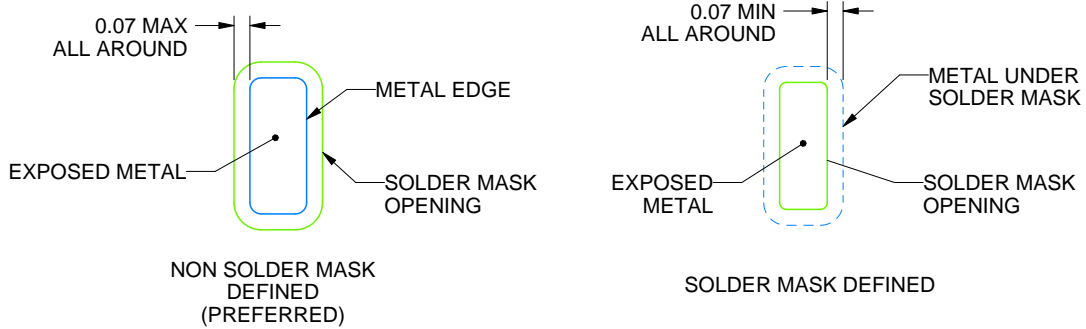

SOLDER MASK DETAILS

4220563/A 03/2021

NOTES: (continued)

- This package is designed to be soldered to a thermal pad on the board. For more information, see Texas Instruments literature number SLUA271 (www.ti.com/lit/slua271).

EXAMPLE STENCIL DESIGN

DQF0008A

WSON - 0.8 mm max height

PLASTIC SMALL OUTLINE - NO LEAD

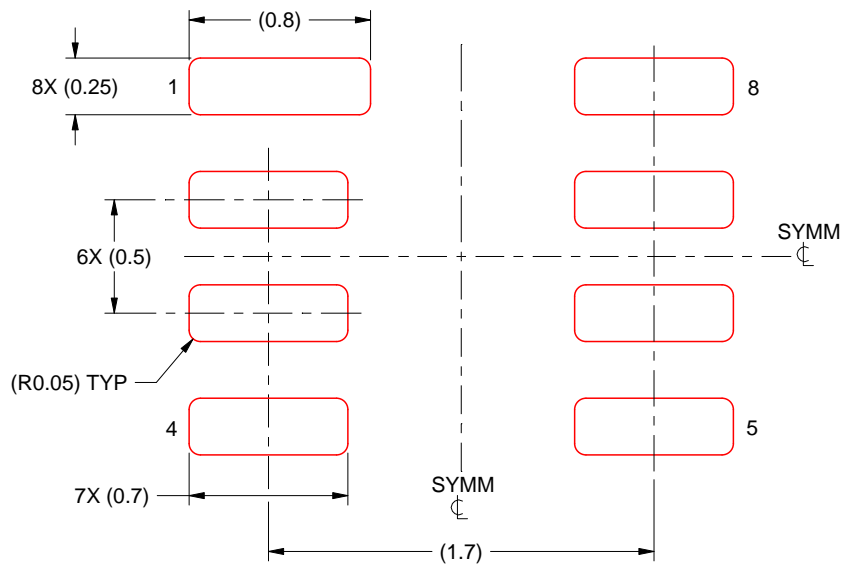

SOLDER PASTE EXAMPLE
BASED ON 0.125 MM THICK STENCIL
SCALE: 30X

4220563/A 03/2021

NOTES: (continued)

4. Laser cutting apertures with trapezoidal walls and rounded corners may offer better paste release. IPC-7525 may have alternate design recommendations.

重要声明和免责声明

TI 提供技术和可靠性数据（包括数据表）、设计资源（包括参考设计）、应用或其他设计建议、网络工具、安全信息和其他资源，不保证没有瑕疵且不做任何明示或暗示的担保，包括但不限于对适销性、某特定用途方面的适用性或不侵犯任何第三方知识产权的暗示担保。

这些资源可供使用 TI 产品进行设计的熟练开发人员使用。您将自行承担以下全部责任：(1) 针对您的应用选择合适的 TI 产品，(2) 设计、验证并测试您的应用，(3) 确保您的应用满足相应标准以及任何其他安全、安保或其他要求。这些资源如有变更，恕不另行通知。TI 授权您仅可将这些资源用于研发本资源所述的 TI 产品的应用。严禁对这些资源进行其他复制或展示。您无权使用任何其他 TI 知识产权或任何第三方知识产权。您应全额赔偿因在这些资源的使用中对 TI 及其代表造成的任何索赔、损害、成本、损失和债务，TI 对此概不负责。

TI 提供的产品受 TI 的销售条款 (<https://www.ti.com.cn/zh-cn/legal/termsofsale.html>) 或 [ti.com.cn](https://www.ti.com.cn) 上其他适用条款/TI 产品随附的其他适用条款的约束。TI 提供这些资源并不会扩展或以其他方式更改 TI 针对 TI 产品发布的适用的担保或担保免责声明。

邮寄地址：上海市浦东新区世纪大道 1568 号中建大厦 32 楼，邮政编码：200122

Copyright © 2021 德州仪器半导体技术（上海）有限公司