

LP50xx 9/12 通道、12 位 PWM 超低静态电流 I²C RGB LED 驱动器

1 特性

- 工作电压范围：
 - V_{CC} 范围：2.7V 至 5.5V
 - EN、SDA 和 SCL 引脚与 1.8V、3.3V 和 5V 电源轨兼容。
 - 最大输出电压：6V
- 12 路高精度恒定电流阱
 - 在整个 V_{CC} 范围内，每个通道的最大电流为 25.5mA
 - 当 $V_{CC} \geq 3.3V$ 时，每个通道的最大电流为 35mA
 - 器件间的误差： $\pm 5\%$ ；通道间的误差： $\pm 5\%$
- 超低静态电流：
 - 关断模式：1 μA （最大值），EN 处于低电平
 - 节能模式：10 μA （典型值），EN 处于高电平，并且所有 LED 在超过 30ms 后关闭
- 每个通道都具有集成式 12 位、29kHz PWM 发生器：
 - 每个通道都具有独立的色彩混合寄存器
 - 每个 RGB LED 模块都具有独立的亮度控制寄存器
 - 可选的对数或线性标度亮度控制
 - 集成三相 PWM 相移方案
- 3 个可编程组（R、G、B），可轻松对每种颜色进行软件控制
- 2 个外部硬件地址引脚允许连接多达 4 个器件
- 广播从地址允许同时配置多个器件
- 自动递增允许在一次传输期间写入或读取多个连续的寄存器
- 高达 400kHz 的快速模式 I²C 速度

2 应用

用于以下设备的 LED 照明、指示灯和闪烁光：

- 智能扬声器（带语音助理）
- 智能家用电器
- 可视门铃
- 电子智能锁
- 烟雾和热量探测器
- STB 和 DVR
- 智能路由器
- 手持设备

3 说明

在智能家居以及配备人机交互功能的其他应用中，高性能 RGB LED 驱动器必不可少。LED 动画效果（如闪烁、呼吸以及追逐）可极大地改善用户体验，同时最大限度地降低系统噪声也至关重要。

LP50xx 器件是一款 9/12 通道恒定电流阱 LED 驱动器。LP50xx 器件包含集成式色彩混合和亮度控制，并且预配置特性可简化软件编码过程。为每个通道配备的集成式 12 位、29kHz PWM 发生器可使 LED 色彩流畅、生动，并消除可闻噪声。

器件信息(1)

器件型号	封装	封装尺寸（标称值）
LP5009	WQFN (20)	3.00mm x 3.00mm
LP5012		

(1) 如需了解所有可用封装，请参阅数据表末尾的可订购产品目录。

简化原理图

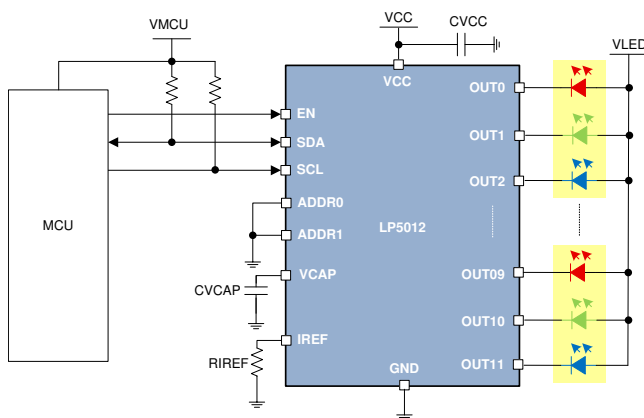

目录

1	特性	1	8.4	Device Functional Modes	17
2	应用	1	8.5	Programming	18
3	说明	1	8.6	Register Maps	22
4	修订历史记录	2	9	Application and Implementation	33
5	说明 (续)	3	9.1	Application Information	33
6	Pin Configuration and Functions	4	9.2	Typical Application	33
7	Specifications	6	10	Power Supply Recommendations	35
7.1	Absolute Maximum Ratings	6	11	Layout	35
7.2	ESD Ratings	6	11.1	Layout Guidelines	35
7.3	Recommended Operating Conditions	6	11.2	Layout Examples	36
7.4	Thermal Information	6	12	器件和文档支持	38
7.5	Electrical Characteristics	7	12.1	相关链接	38
7.6	Timing Characteristics	8	12.2	接收文档更新通知	38
7.7	Typical Characteristics	9	12.3	社区资源	38
8	Detailed Description	11	12.4	商标	38
8.1	Overview	11	12.5	静电放电警告	38
8.2	Functional Block Diagram	11	12.6	Glossary	38
8.3	Feature Description	11	13	机械、封装和可订购信息	38

4 修订历史记录

Changes from Original (May 2019) to Revision A

Page

• 已更改 将“高级信息”更改为“生产数据”	1
------------------------------	----------

5 说明（续）

LP50xx 以 12 位 PWM 分辨率和 29kHz 开关频率控制每个 LED 输出，这有助于实现平滑的调光效果和消除可闻噪声。独立的色彩混合和亮度控制寄存器使软件编码变得非常简单。在以淡入淡出类型的呼吸效果为目标时，全局 R、G、B 组控制可显著减轻微控制器负载。LP50xx 还可以实现 PWM 相移功能，以帮助在多个 LED 同时打开时降低输入功率预算。

LP50xx 器件可实现自动节能模式，以实现超低静态电流。当所有通道都关断 30ms 时，该器件的总功耗会降至 10 μ A，这使得 LP50xx 器件成为电池供电终端设备的潜在选择。

6 Pin Configuration and Functions

LP5009 RUK Package
20-Pin WQFN With Exposed Thermal Pad
Top View

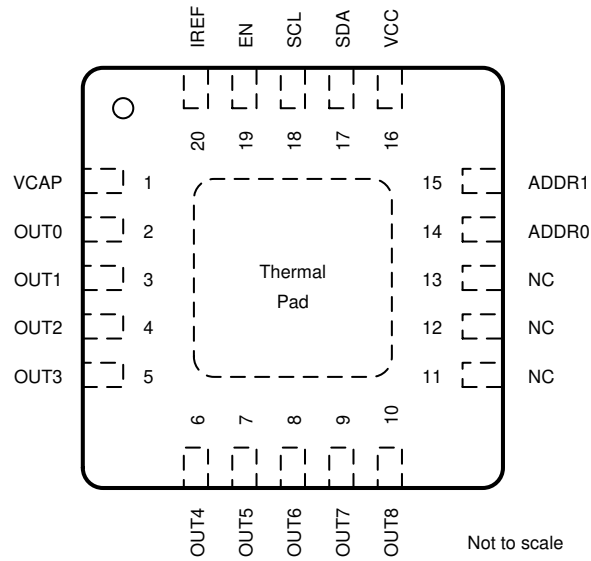

LP5012 RUK Package
20-Pin WQFN With Exposed Thermal Pad
Top View

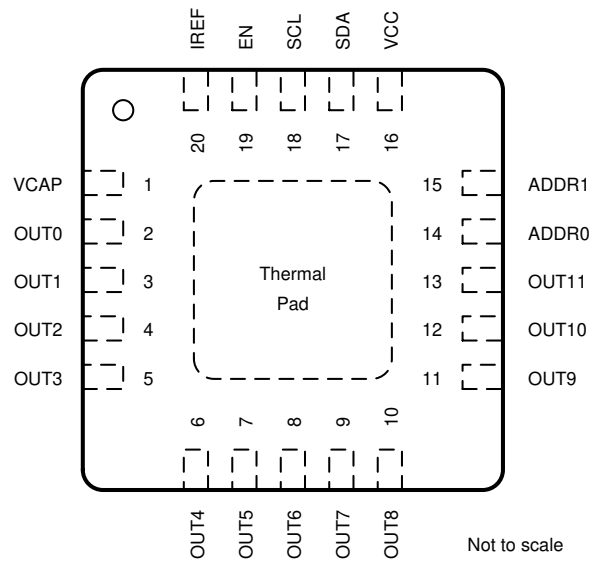

Pin Functions

NAME	PIN		I/O	DESCRIPTION
	NO.			
	LP5009	LP5012		
ADDR0	14	14	—	I ² C slave-address selection pin. This pin must not be left floating.
ADDR1	15	15	—	I ² C slave-address selection pin. This pin must not be left floating.
EN	19	19	I	Chip enable input pin
IREF	20	20	—	Output current-reference global-setting pin
NC	11, 12, 13	—	—	No internal connection
OUT0	2	2	O	Current sink output 0. If not used, this pin can be left floating.
OUT1	3	3	O	Current sink output 1. If not used, this pin can be left floating.
OUT2	4	4	O	Current sink output 2. If not used, this pin can be left floating.
OUT3	5	5	O	Current sink output 3. If not used, this pin can be left floating.
OUT4	6	6	O	Current sink output 4. If not used, this pin can be left floating.
OUT5	7	7	O	Current sink output 5. If not used, this pin can be left floating.
OUT6	8	8	O	Current sink output 6. If not used, this pin can be left floating.
OUT7	9	9	O	Current sink output 7. If not used, this pin can be left floating.
OUT8	10	10	O	Current sink output 8. If not used, this pin can be left floating.
OUT9	—	11	O	Current sink output 9. If not used, this pin can be left floating.
OUT10	—	12	O	Current sink output 10. If not used, this pin can be left floating.
OUT11	—	13	O	Current sink output 11. If not used, this pin can be left floating.
SCL	18	18	I	I ² C bus clock line. If not used, this pin must be connected to GND or VCC.
SDA	17	17	I/O	I ² C bus data line. If not used, this pin must be connected to GND or VCC.
VCAP	1	1	—	Internal LDO output pin, this pin must be connected to a 1- μ F capacitor to GND. Place the capacitor as close to the device as possible.
VCC	16	16	I	Input power.
GND	—	—	—	Exposed thermal pad also serves the ground pin for the device.

7 Specifications

7.1 Absolute Maximum Ratings

over operating ambient temperature range (unless otherwise noted)⁽¹⁾

	MIN	MAX	UNIT
Voltage on EN, IREF, OUTx, SCL, SDA, VCC	-0.3	6	V
Voltage on ADDR _x	-0.3	VCC+0.3	V
Voltage on VCAP	-0.3	2	V
Continuous power dissipation	Internally limited		
Junction temperature, T _{J-MAX}	-40	125	°C
Storage temperature, T _{stg}	-65	150	°C

- (1) Stresses beyond those listed under *Absolute Maximum Ratings* may cause permanent damage to the device. These are stress ratings only, which do not imply functional operation of the device at these or any other conditions beyond those indicated under *Recommended Operating Conditions*. Exposure to absolute-maximum-rated conditions for extended periods may affect device reliability.

7.2 ESD Ratings

			VALUE	UNIT
V _(ESD)	Electrostatic discharge	Human-body model (HBM), per ANSI/ESDA/JEDEC JS-001 ⁽¹⁾	±4000	V
		Charged-device model (CDM), per JEDEC specification JESD22-C101 ⁽²⁾	±1500	

- (1) JEDEC document JEP155 states that 500-V HBM allows safe manufacturing with a standard ESD control process. Manufacturing with less than 500-V HBM is possible with the necessary precautions.
 (2) JEDEC document JEP157 states that 250-V CDM allows safe manufacturing with a standard ESD control process. Manufacturing with less than 250-V CDM is possible with the necessary precautions.

7.3 Recommended Operating Conditions

over operating ambient temperature range (unless otherwise noted)

	MIN	MAX	UNIT
Input voltage on VCC	2.7	5.5	V
Voltage on OUT _x	0	5.5	V
Voltage on ADDR _x , EN, SDA, SCL	0	5.5	V
Operating ambient temperature, T _A	-40	85	°C

7.4 Thermal Information

THERMAL METRIC ⁽¹⁾		LP5009 or LP5012	UNIT
		RUK (QFN)	
		20 PINS	
R _{θJA}	Junction-to-ambient thermal resistance	53.7	°C/W
R _{θJC(top)}	Junction-to-case (top) thermal resistance	55.3	°C/W
R _{θJB}	Junction-to-board thermal resistance	27.4	°C/W
ψ _{JT}	Junction-to-top characterization parameter	1.9	°C/W
ψ _{JB}	Junction-to-board characterization parameter	27.4	°C/W
R _{θJC(bot)}	Junction-to-case (bottom) thermal resistance	12.9	°C/W

- (1) For more information about traditional and new thermal metrics, see the [Semiconductor and IC Package Thermal Metrics](#) application report.

7.5 Electrical Characteristics

over operating ambient temperature range ($-40^{\circ}\text{C} < T_A < 85^{\circ}\text{C}$) (unless otherwise noted)

PARAMETER		TEST CONDITIONS	MIN	TYP	MAX	UNIT
POWER SUPPLIES (VCC)						
V_{VCC}	Supply voltage		2.7		5.5	V
I_{VCC}	Shutdown supply current	$V_{EN} = 0\text{ V}$		0.2	1	μA
	Standby supply current	$V_{EN} = 3.3\text{ V}$, Chip_EN = 0 (bit)		6	10	μA
	Normal-mode supply current	With 10-mA LED current per OUTx		4	6	mA
	Power-save mode supply current	$V_{EN} = 3.3\text{ V}$, Chip_EN = 1 (bit), Power_Save_EN = 1 (bit), all the LEDs off duration $> t_{PSM}$		6	10	μA
V_{UVR}	Undervoltage restart	V_{VCC} rising			2.5	V
V_{UVF}	Undervoltage shutdown	V_{VCC} falling	2			V
V_{UV_HYS}	Undervoltage shutdown hysteresis			0.2		V
OUTPUT STAGE (OUTx)						
I_{MAX}	Maximum sink current (OUT0–OUTx) (For LP5012, x = 11. For LP5009, x = 8.)	V_{VCC} in full range, Max_Current_Option = 0 (bit), PWM = 100%			25.5	mA
	Maximum sink current (OUT0–OUTx) (For LP5012, x = 11. For LP5009, x = 8.)	$V_{VCC} \geq 3.3\text{ V}$, Max_Current_Option = 1 (bit), PWM = 100%			35	
I_{LIM}	Internal sink current limit (OUT0–OUTx) (For LP5012, x = 11. For LP5009, x = 8.)	V_{VCC} in full range, Max_Current_Option = 0 (bit), $V_{IREF} = 0\text{ V}$	35	55	85	mA
	Internal sink current limit (OUT0–OUTx) (For LP5012, x = 11. For LP5009, x = 8.)	$V_{VCC} \geq 3.3\text{ V}$, Max_Current_Option=1 (bit), $V_{IREF} = 0\text{ V}$	40	75	120	
I_{lkg}	Leakage current (OUT0–OUTx) (For LP5012, x = 11. For LP5009, x = 8.)	PWM = 0%		0.1	1	μA
I_{ERR_DD}	Device to device current error, $I_{ERR_DD} = (I_{AVE} - I_{SET}) / I_{SET} \times 100\%$	Channels' current are set to 10 mA. PWM = 100%. Already includes the V_{IREF} and K_{IREF} tolerance	-5%		5%	
I_{ERR_CC}	Channel to channel current error, $I_{ERR_CC} = (I_{OUTx} - I_{AVE}) / I_{AVE} \times 100\%$	Channels' current are set to 10 mA. PWM = 100%. Already includes the V_{IREF} and K_{IREF} tolerance	-5%		5%	
V_{IREF}	IREF voltage			0.7		V
K_{IREF}	IREF ratio			105		
f_{PWM}	PWM switching frequency		21	29		kHz
V_{SAT}	Output saturation voltage	V_{VCC} in full range, Max_Current_Option = 0 (bit), output current set to 20 mA, the voltage when the LED current has dropped 5%		0.25	0.35	V
		$V_{VCC} \geq 3.3\text{ V}$, Max_Current_Option = 1 (bit), output current set to 20 mA, the voltage when the LED current has dropped 5%		0.3	0.4	

Electrical Characteristics (continued)

over operating ambient temperature range ($-40^{\circ}\text{C} < T_A < 85^{\circ}\text{C}$) (unless otherwise noted)

PARAMETER		TEST CONDITIONS	MIN	TYP	MAX	UNIT
LOGIC INPUTS (EN, SCL, SDA, ADDR_x)						
V_{IL}	Low level input voltage				0.4	V
V_{IH}	High level input voltage		1.4			V
I_{LOGIC}	Input current		-1		1	μA
V_{SDA}	SDA output low level	$I_{PULLUP} = 5\text{ mA}$			0.4	V
PROTECTION CIRCUITS						
$T_{(TSD)}$	Thermal-shutdown junction temperature			160		$^{\circ}\text{C}$
$T_{(HYS)}$	Thermal shutdown temperature hysteresis			15		$^{\circ}\text{C}$

7.6 Timing Characteristics

over operating ambient temperature range ($-40^{\circ}\text{C} < T_A < 85^{\circ}\text{C}$) (unless otherwise noted)

PARAMETER		MIN	TYP	MAX	UNIT
f_{OSC}	Internal oscillator frequency		15		MHz
t_{PSM}	Power save mode deglitch time	20	30	40	ms
t_{EN_H}	EN first rising edge until first I ² C access			500	μs
t_{EN_L}	EN first falling edge until first I ² C reset			3	μs
f_{SCL}	I ² C clock frequency			400	kHz
1	Hold time (repeated) START condition	0.6			μs
2	Clock low time	1.3			μs
3	Clock high time	600			ns
4	Setup time for a repeated START condition	600			ns
5	Data hold time	0			ns
6	Data setup time	100			ns
7	Rise time of SDA and SCL	$20 + 0.1 C_b$		300	ns
8	Fall time of SDA and SCL	$15 + 0.1 C_b$		300	ns
9	Setup time for STOP condition	600			ns
10	Bus free time between a STOP and a START condition	1.3			μs
C_b	Capacitive load parameter for each bus line Load of 1 pF corresponds to one nanosecond.	10		200	pF



图 1. I²C Timing Parameters

7.7 Typical Characteristics



图 2. I_{OUT} Target vs R_{REF}

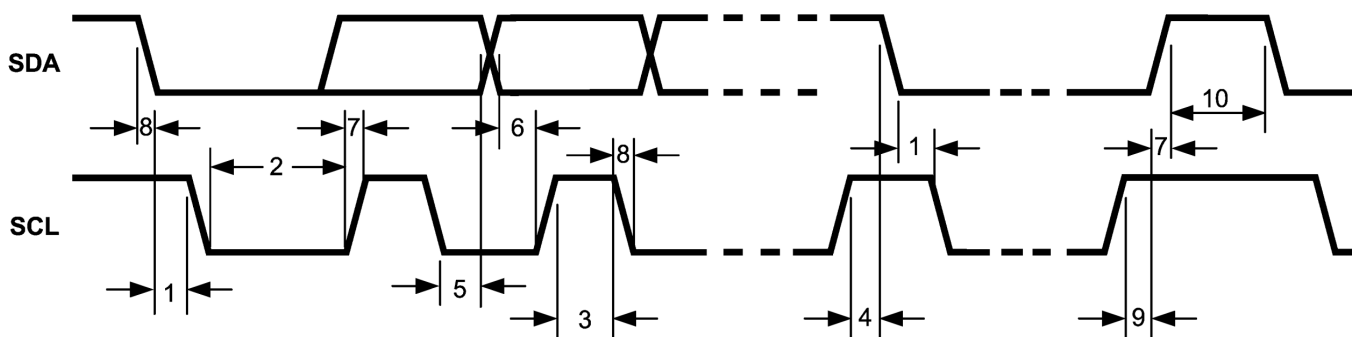

VCC = 3.3 V

图 3. Output Current vs Temperature

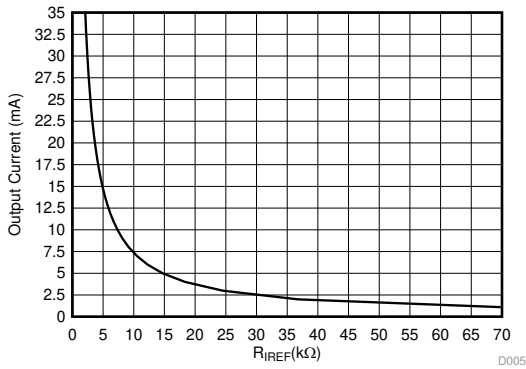
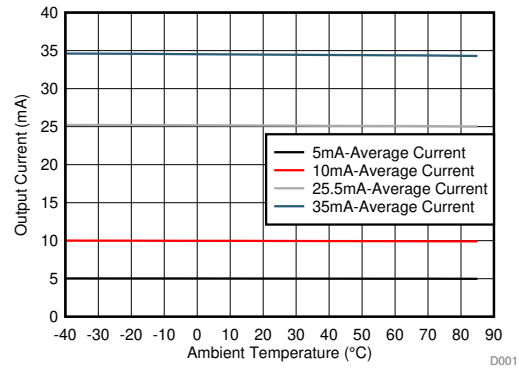
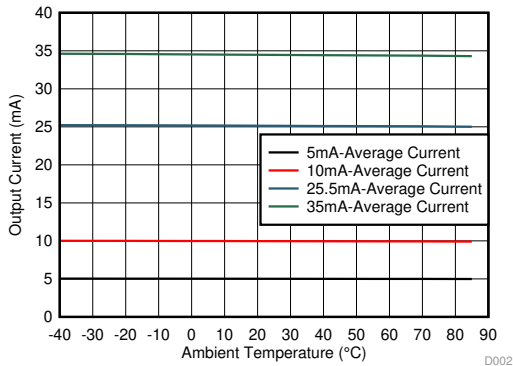

VCC = 5 V

图 4. Output Current vs Temperature

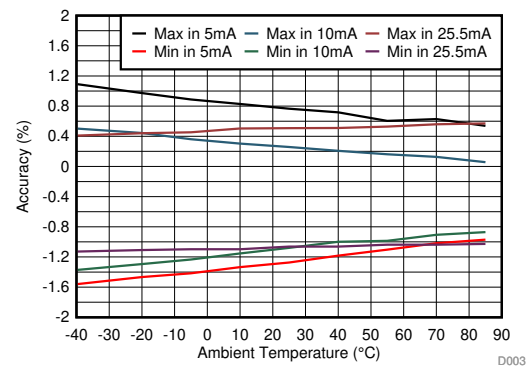

VCC = 3.3 V

图 5. Channel-to-Channel Current Accuracy

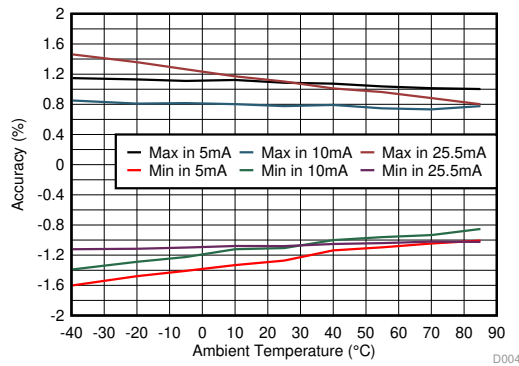

VCC = 5 V

图 6. Channel-to-Channel Current Accuracy vs Temperature

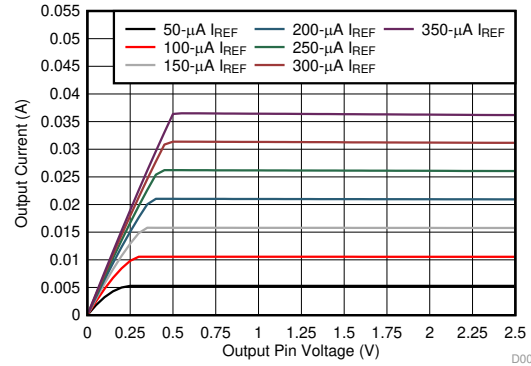

VCC = 3.3 V

图 7. OUT Pin Voltage vs Current

Typical Characteristics (接下页)

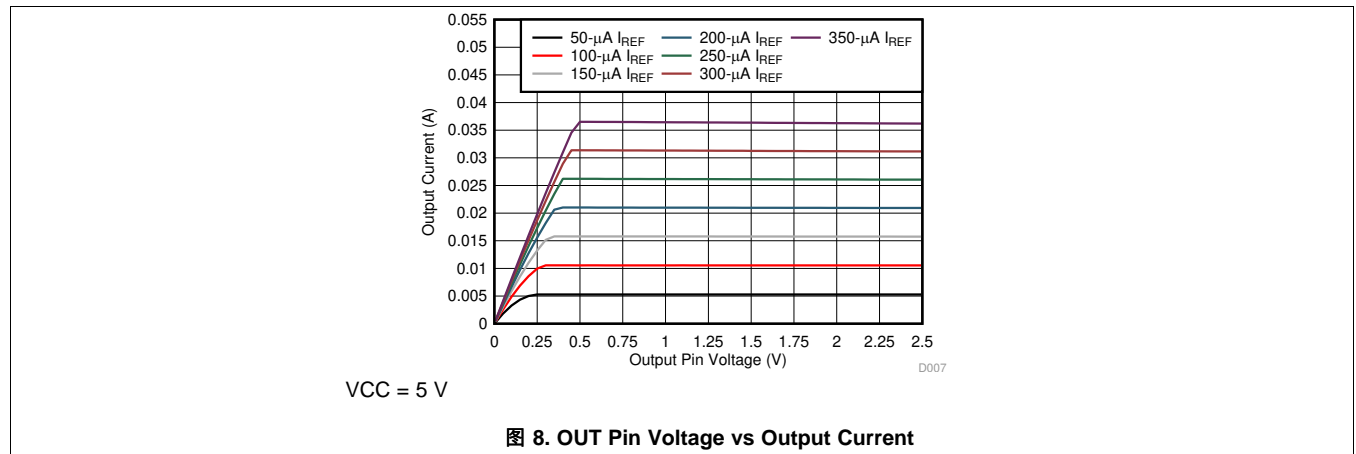

8 Detailed Description

8.1 Overview

The LP50xx device is an 9- or 12-channel constant-current-sink LED driver. The LP50xx device includes all necessary power rails, an on-chip oscillator, and a two-wire serial I²C interface. The maximum constant-current value of all channels is set by a single external resistor. Two hardware address pins allow up to four devices on the same bus. An automatic power-saving mode is implemented to keep the total current consumption under 10 μ A, which makes the LP50xx device a potential choice for battery-powered end equipment.

The LP50xx device is optimized for RGB LEDs regarding both live effects and software efforts. The LP50xx device controls each LED output with 12-bit PWM resolution at 29-kHz switching frequency, which helps achieve a smooth dimming effect and eliminates audible noise. The independent color-mixing and intensity-control registers make the software coding straightforward. When targeting a fade-in, fade-out type breathing effect, the global RGB bank control reduces the microcontroller loading significantly. The LP50xx device also implements a PWM phase-shifting function to help reduce the input power budget when LEDs turn on simultaneously.

8.2 Functional Block Diagram

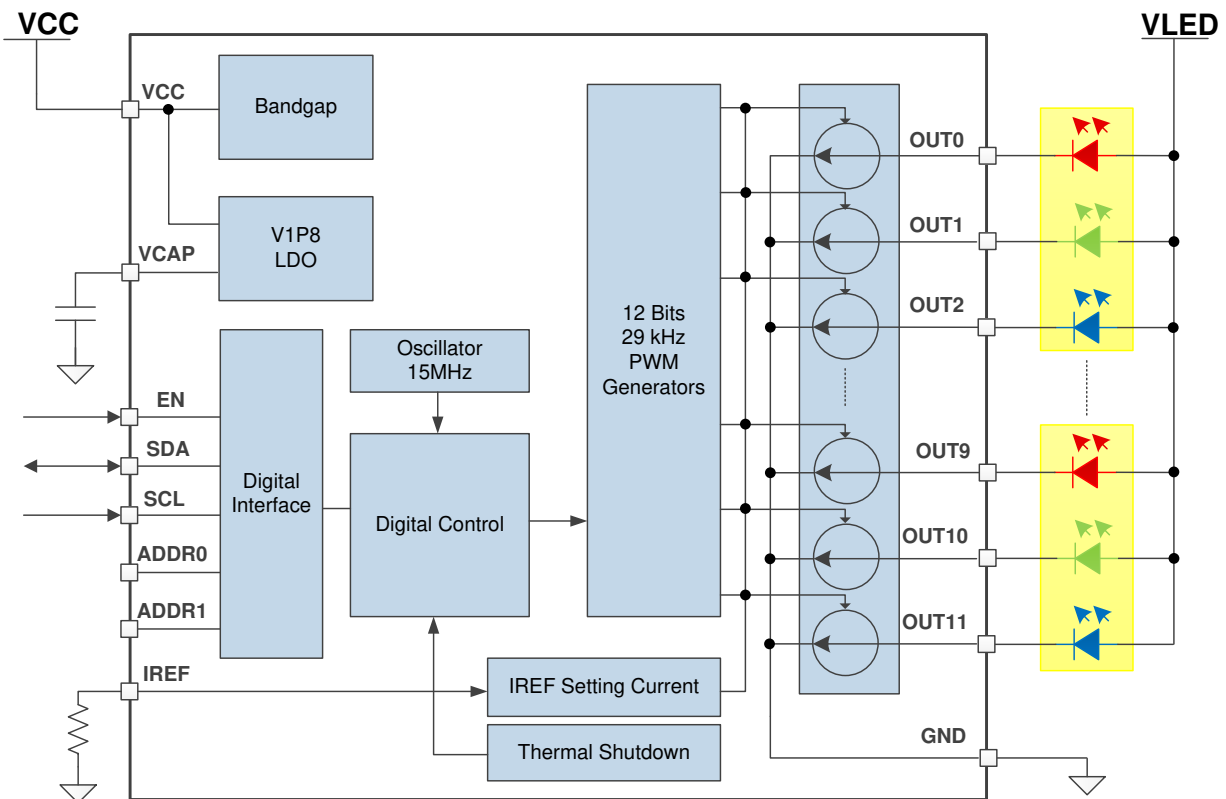

8.3 Feature Description

8.3.1 PWM Control for Each Channel

Most traditional LED drivers are designed for the single-color LEDs, in which the high-resolution PWM generator is used for intensity control only. However, for RGB LEDs, both the color mixing and intensity control must be addressed to achieve the target effect. With the traditional solution, the users must handle the color mixing and intensity control simultaneously with a single PWM register. Several undesired effects occur: the limited dimming steps, the complex software design and the color distortion when using a logarithmic scale control.

Feature Description (接下页)

The LP50xx device is designed with independent color mixing and intensity control, which makes the RGB LED effects fancy and the control experience straightforward. With the inputs of the color-mixing register and the intensity-control register, the final PWM generator output for each channel is 12-bit resolution and 29-kHz dimming frequency, which helps achieve a smooth dimming effect and eliminates audible noise. See 图 9.



图 9. PWM Control Scheme for Each Channel

8.3.1.1 Independent Color Mixing Per RGB LED Module

Each output channel has its own individual 8-bit color-setting register (OUTx_COLOR). The device allows every RGB LED module to achieve >16 million (256 × 256 × 256) color-mixing.

8.3.1.2 Independent Intensity Control Per RGB LED Module

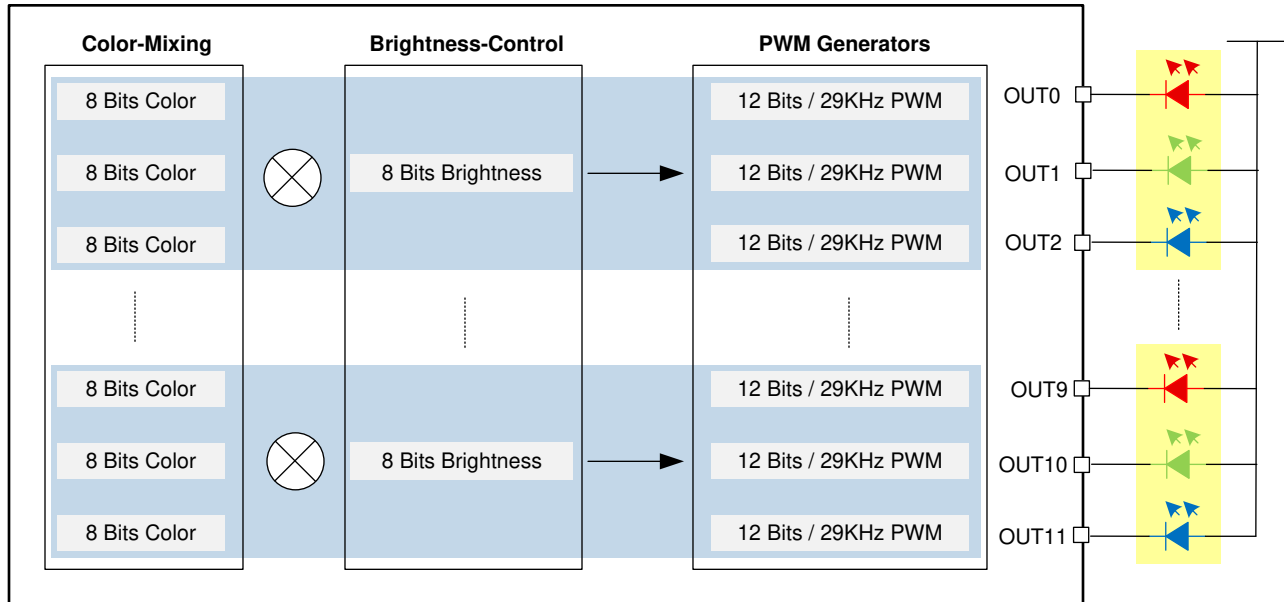
When color is fixed, the independent intensity-control is used to achieve accurate and flexible dimming control for every RGB LED module.

8.3.1.2.1 Intensity-Control Register Configuration

Every three consecutive output channels are assigned to their respective intensity-control register (LEDx_BRIGHTNESS). For example, OUT0, OUT1, and OUT2 are assigned to LED0_BRIGHTNESS, so it is recommended to connect the RGB LEDs in the sequence as shown in 表 1. The LP50xx device allows 256-step intensity control for each RGB LED module, which helps achieve a smooth dimming effect.

Keeping FFh (default value) in the LED0_BRIGHTNESS register results in 100% dimming duty cycle. With this setting, users can just configure the color mixing register by channel to achieve the target dimming effect in a single-color LED application.

8.3.1.2.2 Logarithmic- or Linear-Scale Intensity Control

For human-eye-friendly visual performance, a logarithmic-scale dimming curve is usually implemented in LED drivers. However, for RGB LEDs, if using a single register to achieve both color mixing and intensity control, color distortion can be observed easily when using a logarithmic scale. The LP50xx device, with independent color-mixing and intensity-control registers, implements the logarithmic scale dimming control inside the intensity control function, which solves the color distortion issue effectively. See 图 10. Also, the LP50xx device allows users to configure the dimming scale either logarithmically or linearly through the global Log_Scale_EN register. If a special dimming curve is desired, using the linear scale with software correction is the most flexible approach. See 图 11.

Feature Description (接下页)



图 10. Logarithmic- or Linear-Scale Intensity Control



图 11. Logarithmic vs Linear Dimming Curve

8.3.1.3 12-Bit, 29-kHz PWM Generator Per Channel

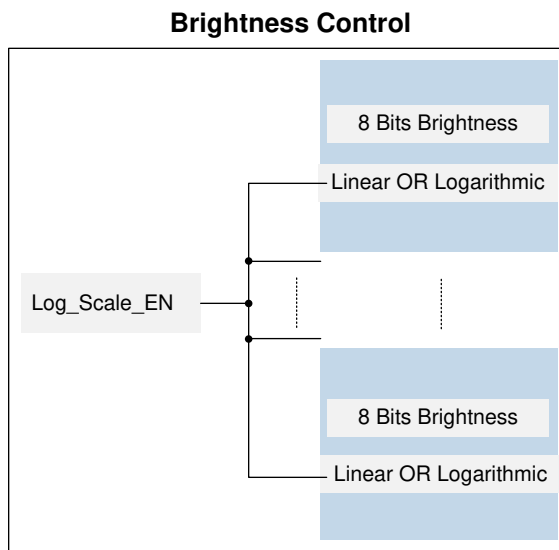
8.3.1.3.1 PWM Generator

With the inputs of the color mixing and the intensity control, the final output PWM duty cycle is defined as the product obtained by multiplying the color-mixing register value by the related intensity-control register value. The final output PWM duty cycle has 12 bits of control accuracy, which is achieved by a 9 bits of pure PWM resolution and 3 bits of digital dithering control. For 3-bit dithering, every eighth pulse is made 1 LSB longer to increase the average value by 1 / 8th. The LP50xx device allows users to enable or disable the dithering function through the PWM_Dithering_EN register. When enabled (default), the output PWM duty-cycle accuracy is 12 bits. When disabled, the output PWM duty-cycle accuracy is 9 bits.

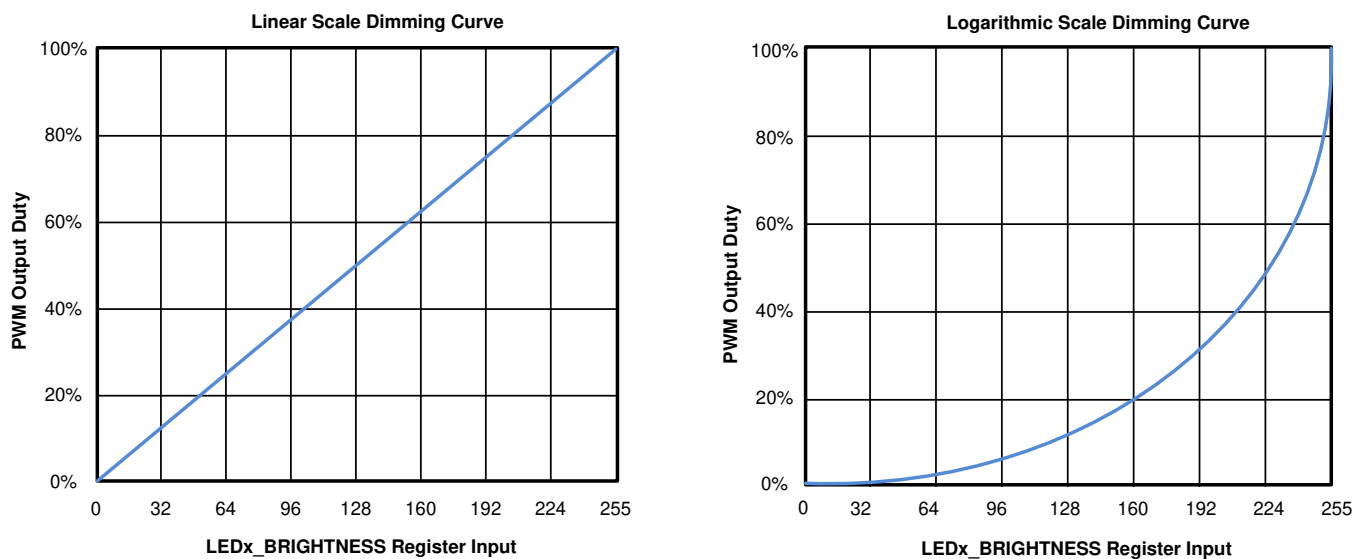
To eliminate the audible noise due to the PWM switching, the LP50xx device sets the PWM switching frequency at 29 kHz, above the 20-kHz human hearing range.

Feature Description (接下页)

8.3.1.4 PWM Phase-Shifting

A PWM phase-shifting scheme allows delaying the time when each LED driver is active. When the LED drivers are not activated simultaneously, the peak load current from the pre-stage power supply is significantly decreased. The scheme also reduces input-current ripple and ceramic-capacitor audible ringing. LED drivers are grouped into three different phases.

- Phase 1—the rising edge of the PWM pulse is fixed. The falling edge of the pulse is changed when the duty cycle changes. Phase 1 is applied to LED0, LED3, LED6, LED9.
- Phase 2—the middle point of the PWM pulse is fixed. The pulse spreads in both directions when the PWM duty cycle is increased. Phase 2 is applied to LED1, LED4, LED7, LED10.
- Phase 3—the falling edge of the PWM pulse is fixed. The rising edge of the pulse is changed when the duty cycle changes. Phase 3 is applied to LED2, LED5, LED8, LED11.



图 12. PWM Phase-Shifting

8.3.2 LED Bank Control

For most LED-animation effects, like blinking and breathing, all the RGB LEDs have the same lighting pattern. Instead of controlling the individual LED separately, which occupies the microcontroller resources heavily, the LP50xx device provides an easy coding approach, the LED bank control.

Each channel can be configured as either independent control or bank control through the LEDx_Bank_EN register. When LEDx_Bank_EN = 0 (default), the LED is controlled independently by the related color-mixing and intensity-control registers. When LEDx_Bank_EN = 1, the LP50xx device drives the LEDs in LED bank-control mode. The LED bank has its own independent PWM control scheme, which is the same structure as the PWM scheme of each channel. See [PWM Control for Each Channel](#) for more details. When a channel is configured in LED bank-control mode, the related color mixing and intensity control is governed by the bank control registers (BANK_A_COLOR, BANK_B_COLOR, BANK_C_COLOR, and BANK_BRIGHTNESS) regardless of the inputs on its own color-mixing and intensity-control registers.

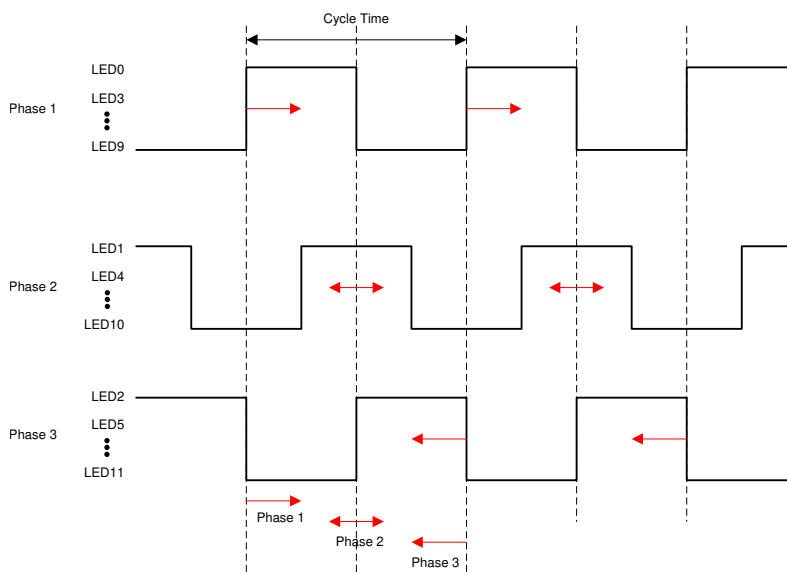
Feature Description (接下页)



图 13. Bank PWM Control Scheme

表 1. Bank Number and LED Number Assignment

OUT NUMBER	BANK NUMBER	RGB LED MODULE NUMBER
OUT0	Bank A	LED0
OUT1	Bank B	
OUT2	Bank C	
OUT3	Bank A	LED1
OUT4	Bank B	
OUT5	Bank C	
OUT6	Bank A	LED2
OUT7	Bank B	
OUT8	Bank C	
OUT9 (LP5012 only)	Bank A	LED3
OUT10 (LP5012 only)	Bank B	
OUT11 (LP5012 only)	Bank C	

With the bank control configuration, the LP50xx device enables users to achieve smooth and live LED effects globally with an ultrasimple software effort. 图 14 shows an example using LED0 as an independent RGB indicator and others with group breathing effect.

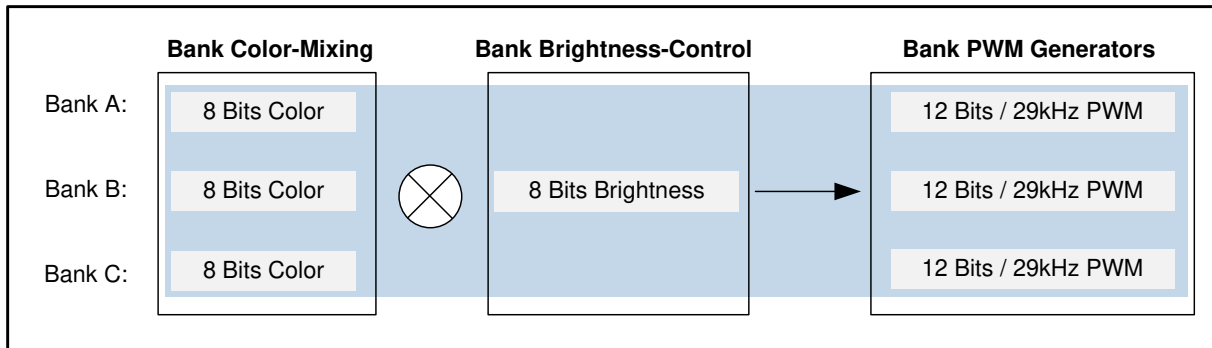

图 14. Bank PWM Control Example

8.3.3 Current Range Setting

The constant-current value (I_{SET}) of all 12 channels is set by a single external resistor, R_{IREF} . The value of R_{IREF} can be calculated by [公式 1](#).

$$R_{IREF} = K_{IREF} \times \frac{V_{IREF}}{I_{SET}}$$

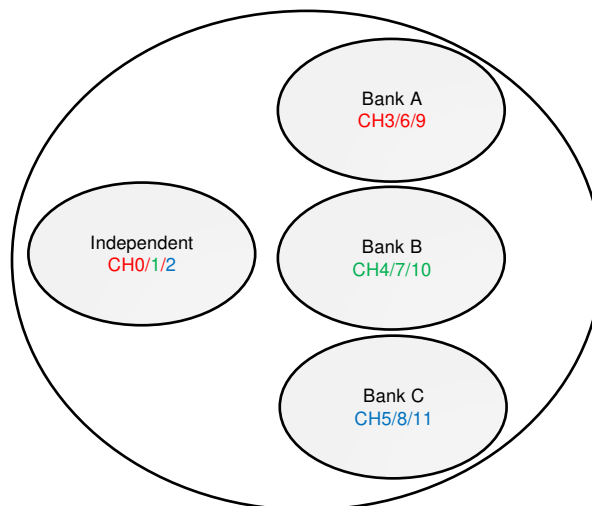
where:

- $K_{IREF} = 105$
 - $V_{IREF} = 0.7 \text{ V}$
- (1)

With the IREF pin floating, the output current is close to zero. With the IREF pin shorted to GND, the LP50xx device provides internal current-limit protection, and the output-channel maximum current is limited to I_{LIM} .

The LP50xx device supports two levels of maximum output current, I_{MAX} .

- When V_{CC} is in the range from 2.7 V to 5.5 V, and the Max_Current_Option (bit) = 0, $I_{MAX} = 25.5 \text{ mA}$.
- When V_{CC} is in the range from 3.3 V to 5.5 V, and the Max_Current_Option (bit) = 1, $I_{MAX} = 35 \text{ mA}$.

8.3.4 Automatic Power-Save Mode

When all the LED outputs are inactive, the LP50xx device is able to enter power-save mode automatically, thus lowering idle-current consumption down to 10 μA (typical). Automatic power-save mode is enabled when register bit Power_Save_EN = 1 (default) and all the LEDs are off for a duration of > 30 ms. Almost all analog blocks are powered down in power-save mode. If any I²C command to the device occurs, the LP50xx device returns to NORMAL mode.

8.3.5 Protection Features

8.3.5.1 Thermal Shutdown

The LP50xx device implements a thermal shutdown mechanism to protect the device from damage due to overheating. When the junction temperature rises to 160°C (typical), the device switches into shutdown mode. The LP50xx device releases thermal shutdown when the junction temperature of the device is reduced to 145°C (typical).

8.3.5.2 UVLO

The LP50xx device has an internal comparator that monitors the voltage at V_{CC} . When V_{CC} is below V_{UVF} , reset is active and the LP50xx device is in the INITIALIZATION state.

8.4 Device Functional Modes



图 15. Functional Modes

- **INITIALIZATION:** The device enters into INITIALIZATION mode when EN = H. In this mode, all the registers are reset. Entry can also be from any state, if the RESET (register) = FFh or UVLO is active.
- **NORMAL:** The device enters the NORMAL mode when Chip_EN (register) = 1. I_{CC} is 10 mA (typical).
- **POWER SAVE:** The device automatically enters the POWER SAVE mode when Power_Save_EN (register) = 1 and all the LEDs are off for a duration of > 30 ms. In POWER SAVE mode, analog blocks are disabled to minimize power consumption, but the registers retain the data and keep it available via I²C. I_{CC} is 10 μ A (typical). In case of any I²C command to this device, it returns to the NORMAL mode.
- **SHUTDOWN:** The device enters into SHUTDOWN mode from all states on V_{CC} power up or when EN = L. I_{CC} is < 1 μ A (maximum).
- **STANDBY:** The device enters the STANDBY mode when Chip_EN (register) = 0. In this mode, all the OUTx pins are shut down, but the registers retain the data and keep it available via I²C. STANDBY is the low-power-consumption mode, when all circuit functions are disabled. I_{CC} is 10 μ A (typical).
- **THERMAL SHUTDOWN:** The device automatically enters the THERMAL SHUTDOWN mode when the junction temperature exceeds 160°C (typical). In this mode, all the OUTx outputs are shut down. If the junction temperature decreases below 145°C (typical), the device returns to the NORMAL mode.

8.5 Programming

8.5.1 I²C Interface

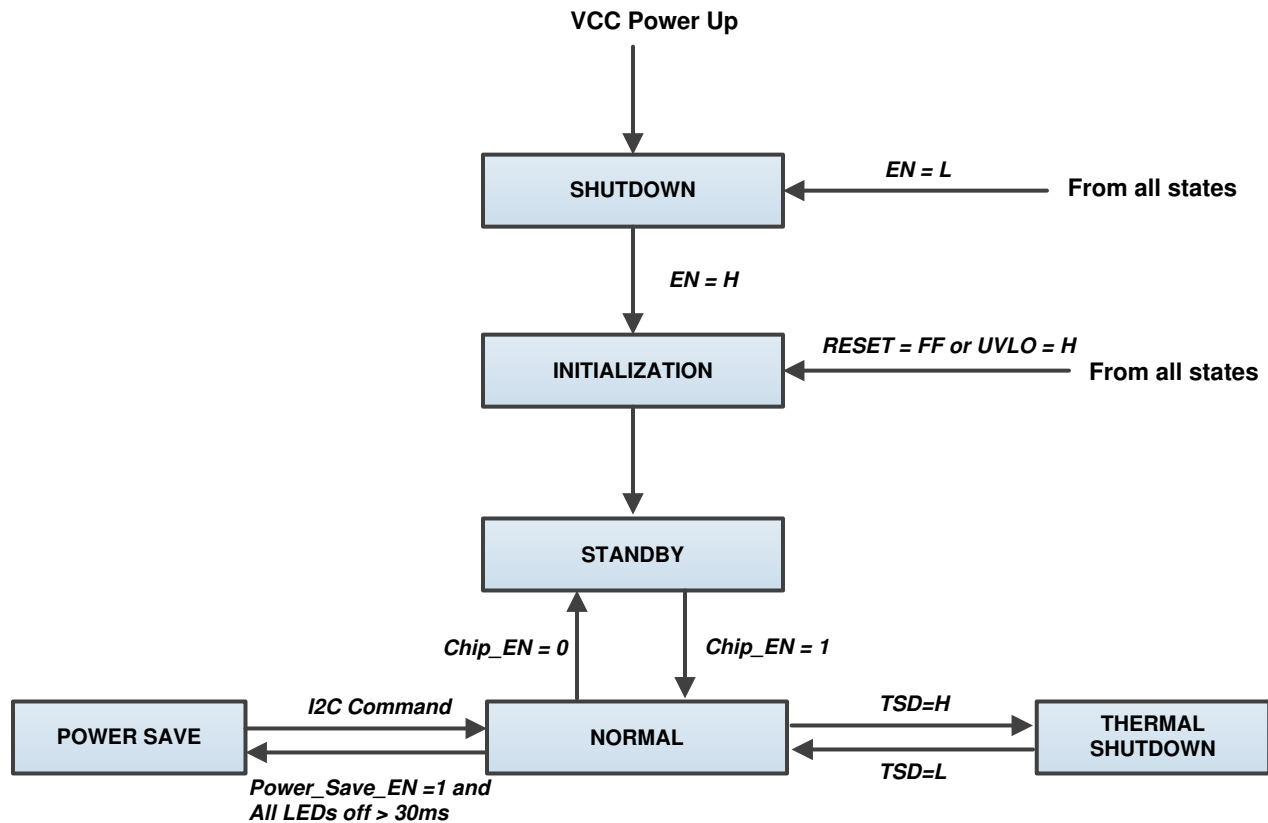
The I²C-compatible two-wire serial interface provides access to the programmable functions and registers on the device. This protocol uses a two-wire interface for bidirectional communications between the devices connected to the bus. The two interface lines are the serial data line (SDA) and the serial clock line (SCL). Every device on the bus is assigned a unique address and acts as either a master or a slave depending on whether it generates or receives the serial clock, SCL. The SCL and SDA lines must each have a pullup resistor placed somewhere on the line and remain HIGH even when the bus is idle.

8.5.1.1 Data Validity

The data on SDA line must be stable during the HIGH period of the clock signal (SCL). In other words, the state of the data line can only be changed when the clock signal is LOW.



图 16. Data Validity

8.5.1.2 Start and Stop Conditions

START and STOP conditions classify the beginning and the end of the data transfer session. A START condition is defined as the SDA signal transitioning from HIGH to LOW while the SCL line is HIGH. A STOP condition is defined as the SDA transitioning from LOW to HIGH while SCL is HIGH. The bus master always generates START and STOP conditions. The bus is considered to be busy after a START condition and free after a STOP condition. During data transmission, the bus master can generate repeated START conditions. First START and repeated START conditions are functionally equivalent.

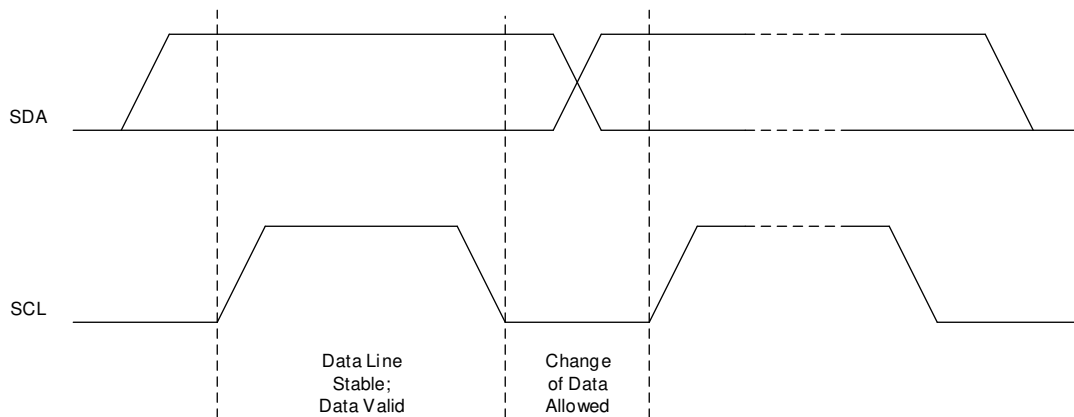

图 17. Start and Stop Conditions

Programming (接下页)

8.5.1.3 Transferring Data

Every byte put on the SDA line must be eight bits long, with the most-significant bit (MSB) being transferred first. Each byte of data must be followed by an acknowledge bit. The acknowledge-related clock pulse is generated by the master. The master releases the SDA line (HIGH) during the acknowledge clock pulse. The device pulls down the SDA line during the ninth clock pulse, signifying an acknowledge. The device generates an acknowledge after each byte has been received.

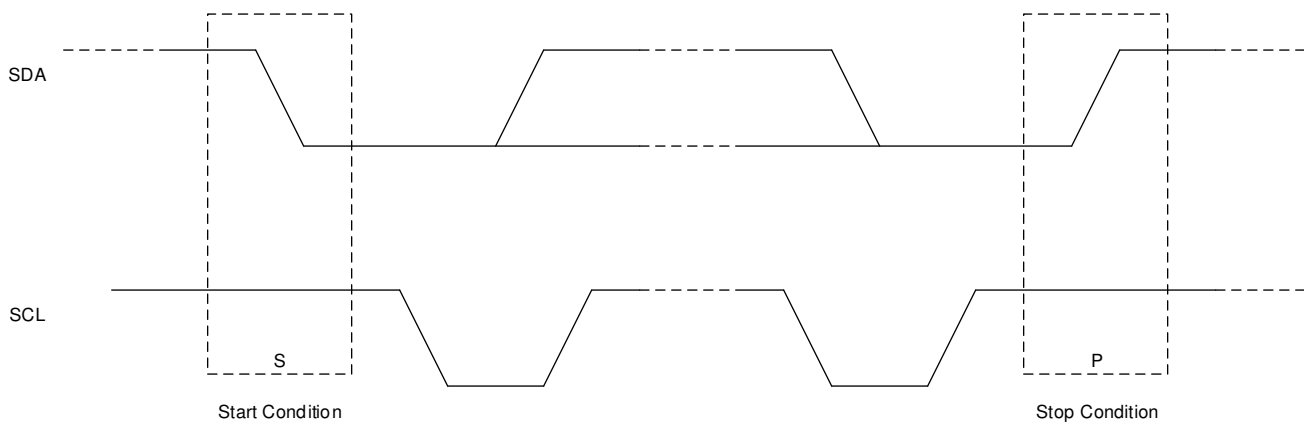
There is one exception to the acknowledge-after-every-byte rule. When the master is the receiver, it must indicate to the transmitter an end of data by not acknowledging (negative acknowledge) the last byte clocked out of the slave. This negative acknowledge still includes the acknowledge clock pulse (generated by the master), but the SDA line is not pulled down.

After the START condition, the bus master sends a chip address. This address is seven bits long followed by an eighth bit which is a data direction bit (READ or WRITE). For the eighth bit, a 0 indicates a WRITE, and a 1 indicates a READ. The second byte selects the register to which the data is written. The third byte contains data to write to the selected register.



图 18. Acknowledge and Not Acknowledge on I²C Bus

8.5.1.4 I²C Slave Addressing

The device slave address is defined by connecting GND or VCC to the ADDR0 and ADDR1 pins. A total of four independent slave addresses can be realized by combinations when GND or VCC is connected to the ADDR0 and ADDR1 pins (see 表 2 and 表 3).

The device responds to a broadcast slave address regardless of the setting of the ADDR0 and ADDR1 pins. Global writes to the broadcast address can be used for configuring all devices simultaneously. The device supports global read using a broadcast address; however, the data read is only valid if all devices on the I²C bus contain the same value in the addressed register.

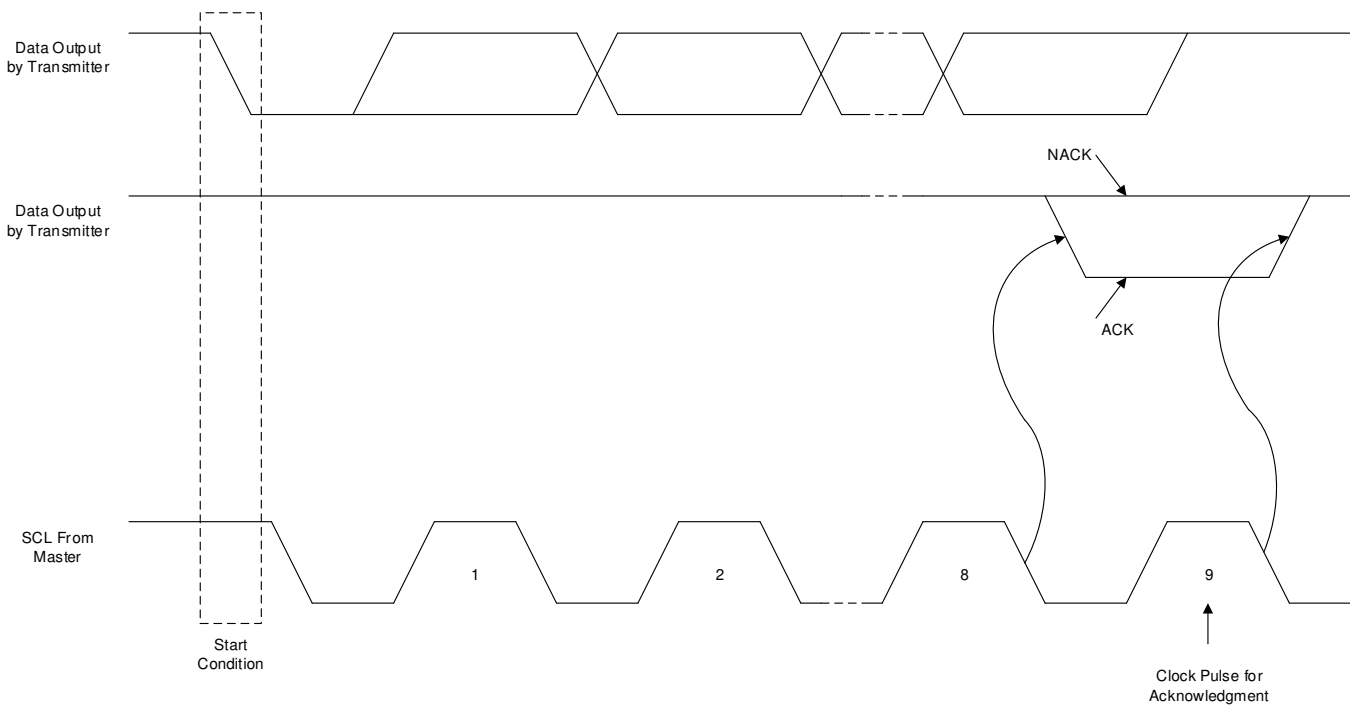
Programming (接下页)
表 2. Slave-Address Combinations

ADDR1	ADDR0	SLAVE ADDRESS	
		INDEPENDENT	BROADCAST
GND	GND	0010100	0001100
GND	VCC	0010101	
VCC	GND	0010110	
VCC	VCC	0010111	

表 3. Chip Address

	SLAVE ADDRESS							R/ \overline{W}
	Bit 7	Bit 6	Bit 5	Bit 4	Bit 3	Bit 2	Bit 1	Bit 0
Independent	0	0	1	0	1	ADDR1	ADDR0	1 or 0
Broadcast	0	0	0	1	1	0	0	1 or 0

8.5.1.5 Control-Register Write Cycle

- The master device generates a start condition.
- The master device sends the slave address (7 bits) and the data direction bit ($R/\overline{W} = 0$).
- The slave device sends an acknowledge signal if the slave address is correct.
- The master device sends the control register address (8 bits).
- The slave device sends an acknowledge signal.
- The master device sends the data byte to be written to the addressed register.
- The slave device sends an acknowledge signal.
- If the master device sends further data bytes, the control register address of the slave is incremented by 1 after the acknowledge signal. To reduce program load time, the device supports address auto incrementation. The register address is incremented after each 8 data bits.
- The write cycle ends when the master device creates a stop condition.

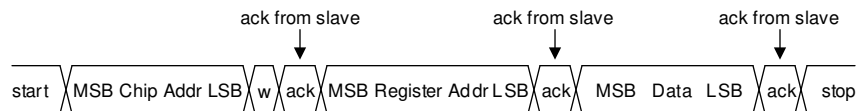
图 19. Write Cycle
8.5.1.6 Control-Register Read Cycle

- The master device generates a start condition.
- The master device sends the slave address (7 bits) and the data direction bit ($R/\overline{W} = 0$).
- The slave device sends an acknowledge signal if the slave address is correct.
- The master device sends the control register address (8 bits).
- The slave device sends an acknowledge signal.
- The master device generates a repeated-start condition.
- The master device sends the slave address (7 bits) and the data direction bit ($R/\overline{W} = 1$).
- The slave device sends an acknowledge signal if the slave address is correct.
- The slave device sends the data byte from the addressed register.
- If the master device sends an acknowledge signal, the control-register address is incremented by 1. The slave device sends the data byte from the addressed register. To reduce program load time, the device supports address auto incrementation. The register address is incremented after each 8 data bits.
- The read cycle ends when the master device does not generate an acknowledge signal after a data byte and generates a stop condition.



图 20. Read Cycle

8.5.1.7 Auto-Increment Feature

The auto-increment feature allows writing or reading several consecutive registers within one transmission. For example, when an 8-bit word is sent to the device, the internal address index counter is incremented by 1, and the next register is written. The auto-increment feature is enabled by default and can be disabled by setting the Auto_Incr_EN bit = 0 in the DEVICE_CONFIG1 register. The auto-increment feature is applied for the full register address from 0h to FFh.

8.6 Register Maps

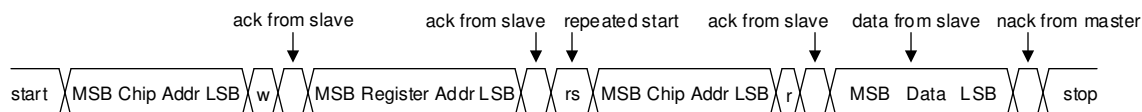
表 4 lists the memory-mapped registers of the device.

表 4. Register Maps

REGISTER NAME	ADDR	TYPE	D7	D6	D5	D4	D3	D2	D1	D0	DEF-AULT
DEVICE_CONFIG0	00h	R \bar{W}	RESERVED	Chip_EN	RESERVED						00h
DEVICE_CONFIG1	01h	R \bar{W}	RESERVED		Log_Scale_EN	Power_Save_EN	Auto_Incr_EN	PWM_Dithering_EN	Max_Current_Option	LED_Global Off	3Ch
LED_CONFIG0	02h	R \bar{W}	RESERVED				LED3_Bank_EN (Only for LP5012)	LED2_Bank_EN	LED1_Bank_EN	LED0_Bank_EN	00h
BANK_BRIGHTNESS	03h	R \bar{W}	Bank_Brightness								FFh
BANK_A_COLOR	04h	R \bar{W}	Bank_A_Color								00h
BANK_B_COLOR	05h	R \bar{W}	Bank_B_Color								00h
BANK_C_COLOR	06h	R \bar{W}	Bank_C_Color								00h
LED0_BRIGHTNESS	07h	R \bar{W}	LED0_Brightness								FFh
LED1_BRIGHTNESS	08h	R \bar{W}	LED1_Brightness								FFh
LED2_BRIGHTNESS	09h	R \bar{W}	LED2_Brightness								FFh
LED3_BRIGHTNESS	0Ah	R \bar{W}	LED3_Brightness (Only for LP5012)								FFh
OUT0_COLOR	0Bh	R \bar{W}	OUT0_Color								00h
OUT1_COLOR	0Ch	R \bar{W}	OUT1_Color								00h
OUT2_COLOR	0Dh	R \bar{W}	OUT2_Color								00h
OUT3_COLOR	0Eh	R \bar{W}	OUT3_Color								00h
OUT4_COLOR	0Fh	R \bar{W}	OUT4_Color								00h
OUT5_COLOR	10h	R \bar{W}	OUT5_Color								00h
OUT6_COLOR	11h	R \bar{W}	OUT6_Color								00h
OUT7_COLOR	12h	R \bar{W}	OUT7_Color								00h
OUT8_COLOR	13h	R \bar{W}	OUT8_Color								00h
OUT9_COLOR	14h	R \bar{W}	OUT9_Color (Only for LP5012)								00h

Register Maps (接下页)
表 4. Register Maps (接下页)

REGISTER NAME	ADDR	TYPE	D7	D6	D5	D4	D3	D2	D1	D0	DEF-AULT
OUT10_COLOR	15h	R \bar{W}	OUT10_Color (Only for LP5012)								00h
OUT11_COLOR	16h	R \bar{W}	OUT11_Color (Only for LP5012)								00h
RESET	17h	W	Reset								00h

表 5. Access Type Codes

ACCESS TYPE	CODE	DESCRIPTION
Read Type		
R	R	Read
Write Type		
W	W	Write
Reset or Default Value		
-n		Value after reset or the default value

8.6.1 DEVICE_CONFIG0 (Address = 0h) [reset = 0h]

DEVICE_CONFIG0 is shown in 图 21 and described in 表 6.

Return to 表 4.

图 21. DEVICE_CONFIG0 Register

7	6	5	4	3	2	1	0
RESERVED	Chip_EN	RESERVED					
R/W-0h	R/W-0h	R/W-0h					

表 6. DEVICE_CONFIG0 Register Field Descriptions

Bit	Field	Type	Reset	Description
7	RESERVED	R/W	0h	Reserved
6	Chip_EN	R/W	0h	1 = LP50xx enabled 0 = LP50xx not enabled
5-0	RESERVED	R/W	0h	Reserved

8.6.2 DEVICE_CONFIG1 (Address = 1h) [reset = 3Ch]

DEVICE_CONFIG1 is shown in 图 22 and described in 表 7.

Return to 表 4.

图 22. DEVICE_CONFIG1 Register

7	6	5	4	3	2	1	0
RESERVED	Log_Scale_EN	Power_Save_EN	Auto_Incr_EN	PWM_Dithering_EN	Optional_Headroom	LED_Global Off	
R/W-0h	R/W-1h	R/W-1h	R/W-1h	R/W-1h	R/W-1h	R/W-0h	

表 7. DEVICE_CONFIG1 Register Field Descriptions

Bit	Field	Type	Reset	Description
7-6	RESERVED	R/W	0h	Reserved
5	Log_Scale_EN	R/W	1h	1 = Logarithmic scale dimming curve enabled 0 = Linear scale dimming curve enabled
4	Power_Save_EN	R/W	1h	1 = Automatic power-saving mode enabled 0 = Automatic power-saving mode not enabled
3	Auto_Incr_EN	R/W	1h	1 = Automatic increment mode enabled 0 = Automatic increment mode not enabled
2	PWM_Dithering_EN	R/W	1h	1 = PWM dithering mode enabled 0 = PWM dithering mode not enabled
1	Max_Current_Option	R/W	0h	1 = Output maximum current I _{MAX} = 35 mA. 0 = Output maximum current I _{MAX} = 25.5 mA.
0	LED_Global Off	R/W	0h	1 = Shut down all LEDs 0 = Normal operation

8.6.3 LED_CONFIG0 (Address = 2h) [reset = 00h]

LED_CONFIG0 is shown in 图 23 and described in 表 8.

Return to 表 4.

图 23. LED_CONFIG0 Register

7	6	5	4	3	2	1	0
RESERVED				LED3_Bank_E	LED2_Bank_E	LED1_Bank_E	LED0_Bank_E
				N	N	N	N
R/W-0h				R/W-0h	R/W-0h	R/W-0h	R/W-0h

表 8. LED_CONFIG0 Register Field Descriptions

Bit	Field	Type	Reset	Description
7-4	RESERVED	R/W	0h	Reserved
3	LED3_Bank_EN	R/W	0h	1 = LED3 bank control mode enabled 0 = LED3 Independent control mode enabled
2	LED2_Bank_EN	R/W	0h	1 = LED2 bank control mode enabled 0 = LED2 independent control mode enabled
1	LED1_Bank_EN	R/W	0h	1 = LED1 bank control mode enabled 0 = LED1 independent control mode enabled
0	LED0_Bank_EN	R/W	0h	1 = LED0 bank control mode enabled 0 = LED0 independent control mode enabled

8.6.4 BANK_BRIGHTNESS (Address = 3h) [reset = FFh]

BANK_BRIGHTNESS is shown in 图 24 and described in 表 9.

Return to 表 4.

图 24. BANK_BRIGHTNESS Register

7	6	5	4	3	2	1	0
Bank_Brightness							
R/W-FFh							

表 9. BANK_BRIGHTNESS Register Field Descriptions

Bit	Field	Type	Reset	Description
7-0	Bank_Brightness	R/W	FFh	FFh = 100% of full brightness ... 80h = 50% of full brightness ... 00h = 0% of full brightness

8.6.5 BANK_A_COLOR (Address = 4h) [reset = 00h]

BANK_A_COLOR is shown in 图 25 and described in 表 10.

Return to 表 4.

图 25. BANK_A_COLOR Register

7	6	5	4	3	2	1	0
Bank_A_Color							
R/W-0h							

表 10. BANK_A_COLOR Register Field Descriptions

Bit	Field	Type	Reset	Description
7–0	Bank_A_Color	R/W	0h	FFh = The color mixing percentage is 100%. ... 80h = The color mixing percentage is 50%. ... 00h = The color mixing percentage is 0%.

8.6.6 BANK_B_COLOR (Address = 5h) [reset = 00h]

 BANK_B_COLOR is shown in [图 26](#) and described in [表 11](#).

 Return to [表 4](#).

图 26. BANK_B_COLOR Register

7	6	5	4	3	2	1	0
Bank_B_Color							
R/W-0h							

表 11. BANK_B_COLOR Register Field Descriptions

Bit	Field	Type	Reset	Description
7–0	Bank_B_Color	R/W	0h	FFh = The color mixing percentage is 100%. ... 80h = The color mixing percentage is 50%. ... 00h = The color mixing percentage is 0%.

8.6.7 BANK_C_COLOR (Address = 6h) [reset = 00h]

 BANK_C_COLOR is shown in [图 27](#) and described in [表 12](#).

 Return to [表 4](#).

图 27. BANK_C_COLOR Register

7	6	5	4	3	2	1	0
Bank_C_Color							
R/W-0h							

表 12. BANK_C_COLOR Register Field Descriptions

Bit	Field	Type	Reset	Description
7–0	Bank_C_Color	R/W	0h	FFh = The color mixing percentage is 100%. ... 80h = The color mixing percentage is 50%. ... 00h = The color mixing percentage is 0%.

8.6.8 LED0_BRIGHTNESS (Address = 7h) [reset = FFh]

 LED0_BRIGHTNESS is shown in [图 28](#) and described in [表 13](#).

 Return to [表 4](#).

图 28. LED0_BRIGHTNESS Register

7	6	5	4	3	2	1	0
LED0_Brightness							
R/W-FFh							

表 13. LED0_BRIGHTNESS Register Field Descriptions

Bit	Field	Type	Reset	Description
7–0	LED0_Brightness	R/W	FFh	FFh = 100% of full intensity ... 80h = 50% of full intensity ... 00h = 0% of full intensity

8.6.9 LED1_BRIGHTNESS (Address = 8h) [reset = FFh]

LED1_BRIGHTNESS is shown in [图 29](#) and described in [表 14](#).

Return to [表 4](#).

图 29. LED1_BRIGHTNESS Register

7	6	5	4	3	2	1	0
LED1_Brightness							
R/W-FFh							

表 14. LED1_BRIGHTNESS Register Field Descriptions

Bit	Field	Type	Reset	Description
7–0	LED1_Brightness	R/W	FFh	FFh = 100% of full intensity ... 80h = 50% of full intensity ... 00h = 0% of full intensity

8.6.10 LED2_BRIGHTNESS (Address = 9h) [reset = FFh]

LED2_BRIGHTNESS is shown in [图 30](#) and described in [表 15](#).

Return to [表 4](#).

图 30. LED2_BRIGHTNESS Register

7	6	5	4	3	2	1	0
LED2_Brightness							
R/W-FFh							

表 15. LED2_BRIGHTNESS Register Field Descriptions

Bit	Field	Type	Reset	Description
7–0	LED2_Brightness	R/W	FFh	FFh = 100% of full intensity ... 80h = 50% of full intensity ... 00h = 0% of full intensity

8.6.11 LED3_BRIGHTNESS (Address = 0Ah) [reset = FFh]

LED3_BRIGHTNESS is shown in [图 31](#) and described in [表 16](#).

Return to [表 4](#).

图 31. LED3_BRIGHTNESS Register

7	6	5	4	3	2	1	0
LED3_Brightness							
R/W-FFh							

表 16. LED3_BRIGHTNESS Register Field Descriptions

Bit	Field	Type	Reset	Description
7–0	LED3_Brightness	R/W	FFh	FFh = 100% of full intensity ... 80h = 50% of full intensity ... 00h = 0% of full intensity

8.6.12 OUT0_COLOR (Address = 0Bh) [reset = 00h]

 OUT0_COLOR is shown in [图 32](#) and described in [表 17](#).

 Return to [表 4](#).

图 32. OUT0_COLOR Register

7	6	5	4	3	2	1	0
OUT0_Color							
R/W-00h							

表 17. OUT0_COLOR Register Field Descriptions

Bit	Field	Type	Reset	Description
7–0	OUT0_Color	R/W	00h	FFh = The color mixing percentage is 0%. ... 80h =The color mixing percentage is 50%. ... 00h = The color mixing percentage is 100%.

8.6.13 OUT1_COLOR (Address = 0Ch) [reset = 00h]

 OUT1_COLOR is shown in [图 33](#) and described in [表 18](#).

 Return to [表 4](#).

图 33. OUT1_COLOR Register

7	6	5	4	3	2	1	0
OUT1_Color							
R/W-00h							

表 18. OUT1_COLOR Register Field Descriptions

Bit	Field	Type	Reset	Description
7–0	OUT1_Color	R/W	00h	FFh = The color mixing percentage is 0%. ... 80h =The color mixing percentage is 50%. ... 00h = The color mixing percentage is 100%.

8.6.14 OUT2_COLOR (Address = 0Dh) [reset = 00h]

 OUT2_COLOR is shown in [图 34](#) and described in [表 19](#).

 Return to [表 4](#).

图 34. OUT2_COLOR Register

7	6	5	4	3	2	1	0
OUT2_Color							
R/W-00h							

表 19. OUT2_COLOR Register Field Descriptions

Bit	Field	Type	Reset	Description
7–0	OUT2_Color	R/W	00h	FFh = The color mixing percentage is 0%. ... 80h =The color mixing percentage is 50%. ... 00h = The color mixing percentage is 100%.

8.6.15 OUT3_COLOR (Address = 0Eh) [reset = 00h]

OUT3_COLOR is shown in [图 35](#) and described in [表 20](#).

Return to [表 4](#).

图 35. OUT3_COLOR Register

7	6	5	4	3	2	1	0
OUT3_Color							
R/W-00h							

表 20. OUT3_COLOR Register Field Descriptions

Bit	Field	Type	Reset	Description
7–0	OUT3_Color	R/W	00h	FFh = The color mixing percentage is 0%. ... 80h =The color mixing percentage is 50%. ... 00h = The color mixing percentage is 100%.

8.6.16 OUT4_COLOR (Address = 0Fh) [reset = 00h]

OUT4_COLOR is shown in [图 36](#) and described in [表 21](#).

Return to [表 4](#).

图 36. OUT4_COLOR Register

7	6	5	4	3	2	1	0
OUT4_Color							
R/W-00h							

表 21. OUT4_COLOR Register Field Descriptions

Bit	Field	Type	Reset	Description
7–0	OUT4_Color	R/W	00h	FFh = The color mixing percentage is 0%. ... 80h =The color mixing percentage is 50%. ... 00h = The color mixing percentage is 100%.

8.6.17 OUT5_COLOR (Address = 10h) [reset = 00h]

OUT5_COLOR is shown in [图 37](#) and described in [表 22](#).

Return to [表 4](#).

图 37. OUT5_COLOR Register

7	6	5	4	3	2	1	0
OUT5_Color							
R/W-00h							

表 22. OUT5_COLOR Register Field Descriptions

Bit	Field	Type	Reset	Description
7–0	OUT5_Color	R/W	00h	FFh = The color mixing percentage is 0%. ... 80h =The color mixing percentage is 50%. ... 00h = The color mixing percentage is 100%.

8.6.18 OUT6_COLOR (Address = 11h) [reset = 00h]

 OUT6_COLOR is shown in [图 38](#) and described in [表 23](#).

 Return to [表 4](#).

图 38. OUT6_COLOR Register

7	6	5	4	3	2	1	0
OUT6_Color							
R/W-00h							

表 23. OUT6_COLOR Register Field Descriptions

Bit	Field	Type	Reset	Description
7–0	OUT6_Color	R/W	00h	FFh = The color mixing percentage is 0%. ... 80h =The color mixing percentage is 50%. ... 00h = The color mixing percentage is 100%.

8.6.19 OUT7_COLOR (Address = 12h) [reset = 00h]

 OUT7_COLOR is shown in [图 39](#) and described in [表 24](#).

 Return to [表 4](#).

图 39. OUT7_COLOR Register

7	6	5	4	3	2	1	0
OUT7_Color							
R/W-00h							

表 24. OUT7_COLOR Register Field Descriptions

Bit	Field	Type	Reset	Description
7–0	OUT7_Color	R/W	00h	FFh = The color mixing percentage is 0%. ... 80h =The color mixing percentage is 50%. ... 00h = The color mixing percentage is 100%.

8.6.20 OUT8_COLOR (Address = 13h) [reset = 00h]

 OUT8_COLOR is shown in [图 40](#) and described in [表 25](#).

 Return to [表 4](#).

图 40. OUT8_COLOR Register

7	6	5	4	3	2	1	0
OUT8_Color							
R/W-00h							

表 25. OUT8_COLOR Register Field Descriptions

Bit	Field	Type	Reset	Description
7–0	OUT8_Color	R/W	00h	FFh = The color mixing percentage is 0%. ... 80h =The color mixing percentage is 50%. ... 00h = The color mixing percentage is 100%.

8.6.21 OUT9_COLOR (Address = 14h) [reset = 00h]

OUT9_COLOR is shown in [图 41](#) and described in [表 26](#).

Return to [表 4](#).

图 41. OUT9_COLOR Register

7	6	5	4	3	2	1	0
OUT9_Color							
R/W-00h							

表 26. OUT9_COLOR Register Field Descriptions

Bit	Field	Type	Reset	Description
7–0	OUT9_Color	R/W	00h	FFh = The color mixing percentage is 0%. ... 80h =The color mixing percentage is 50%. ... 00h = The color mixing percentage is 100%.

8.6.22 OUT10_COLOR (Address = 15h) [reset = 00h]

OUT10_COLOR is shown in [图 42](#) and described in [表 27](#).

Return to [表 4](#).

图 42. OUT10_COLOR Register

7	6	5	4	3	2	1	0
OUT10_Color							
R/W-00h							

表 27. OUT10_COLOR Register Field Descriptions

Bit	Field	Type	Reset	Description
7–0	OUT10_Color	R/W	00h	FFh = The color mixing percentage is 0%. ... 80h =The color mixing percentage is 50%. ... 00h = The color mixing percentage is 100%.

8.6.23 OUT11_COLOR (Address = 16h) [reset = 00h]

OUT11_COLOR is shown in [图 43](#) and described in [表 28](#).

Return to [表 4](#).

图 43. OUT11_COLOR Register

7	6	5	4	3	2	1	0
OUT11_Color							
R/W-00h							

表 28. OUT11_COLOR Register Field Descriptions

Bit	Field	Type	Reset	Description
7–0	OUT11_Color	R/W	00h	FFh = The color mixing percentage is 0%. ... 80h =The color mixing percentage is 50%. ... 00h = The color mixing percentage is 100%.

8.6.24 RESET (Address = 17h) [reset = 00h]

 RESET is shown in [图 44](#) and described in [表 29](#).

 Return to [表 4](#).

图 44. RESET Register

7	6	5	4	3	2	1	0
Reset							
W-00h							

表 29. OUT14_COLOR Register Field Descriptions

Bit	Field	Type	Reset	Description
7–0	Reset	W	00h	FFh = Reset all the registers to default value.

9 Application and Implementation

注

Information in the following applications sections is not part of the TI component specification, and TI does not warrant its accuracy or completeness. TI's customers are responsible for determining suitability of components for their purposes. Customers should validate and test their design implementation to confirm system functionality.

9.1 Application Information

The LP50xx device is a 9- or 12-channel constant-current-sink LED driver. The LP50xx device improves the user experience in color mixing and intensity control, for both live effects and coding effort. The optimized performance for RGB LEDs makes it a good choice for human-machine interaction applications.

9.2 Typical Application

The LP50xx design supports up to four devices in parallel with different configurations on the ADDR0 and ADDR1 pins.



图 45. Driving Dual LP5012 Application Example

Typical Application (接下页)

9.2.1 Design Requirements

Set the LED current to 15 mA using the R_{IREF} resistor. Select the proper value for the other external components, like VCAP pin capacitor and the SCL/SDA pullup resistors.

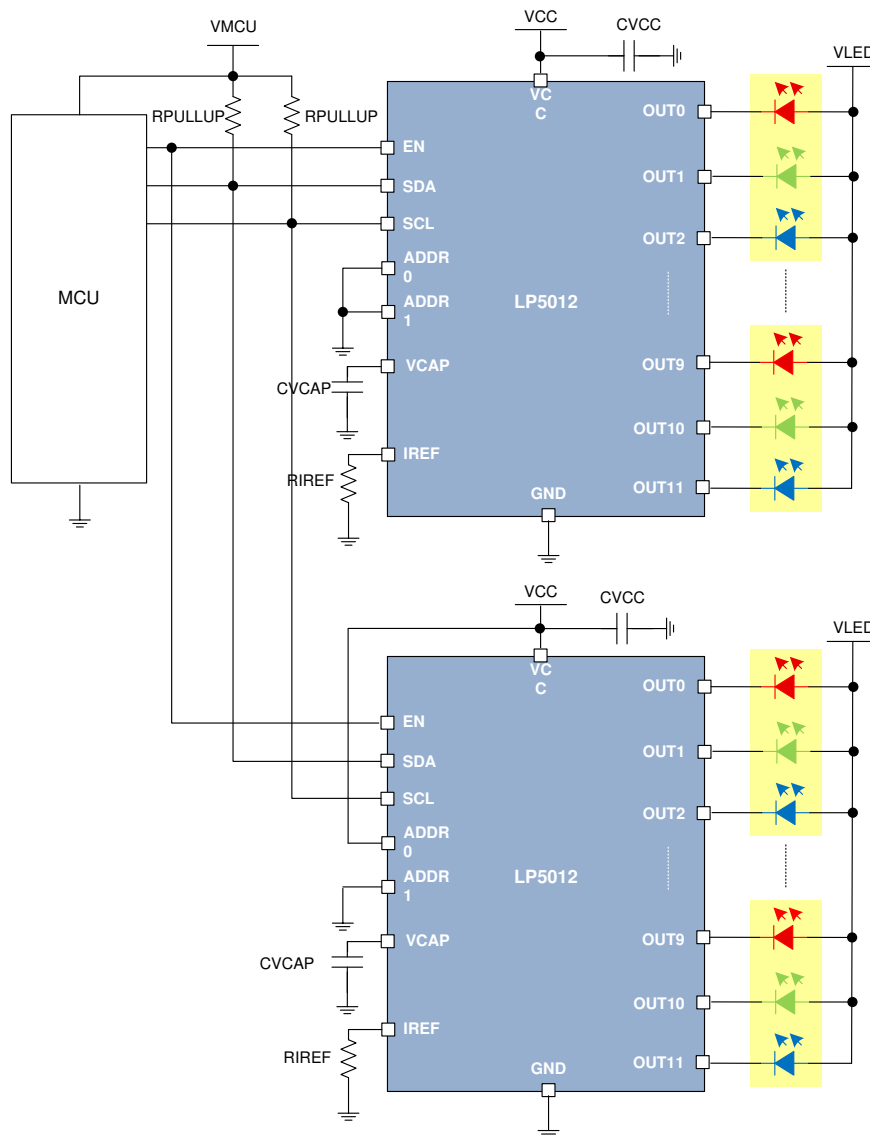
9.2.2 Detailed Design Procedure

LP50xx scales up the reference current (I_{REF}) set by the external resistor (R_{IREF}) to sink the output current (I_{OUT}) at each output port. The following formula can be used to calculate the external resistor (R_{IREF}):

$$R_{IREF} = K_{IREF} \times \frac{V_{IREF}}{I_{SET}} \tag{2}$$

The SCL and SDA lines must each have a pullup resistor placed somewhere on the line (the pullup resistors are normally located on the bus master). In typical applications, values of 1.8 kΩ to 4.7 kΩ are used.

VCAP is internal LDO output pin. This pin must be connected through a 1-μF capacitor to GND. Place the capacitor as close to the device as possible.

TI recommends having a 1-μF capacitor between VCC and GND to ensure proper operation. Place the capacitor as close to the device as possible.

9.2.3 Application Curves

The test condition for is that the testing under bank control, with the register's (0x04,0x05,0x06) value is 0xF0.

The test condition for is that the testing under bank control, with the register's (0x04,0x05,0x06) value is 0x0F.

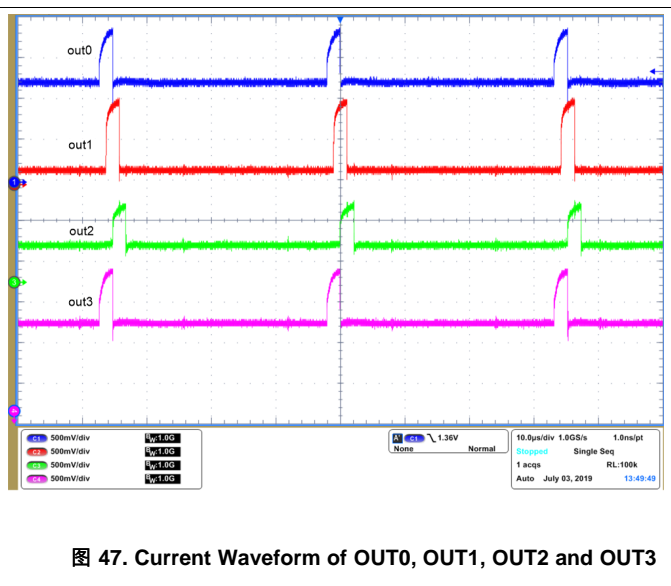
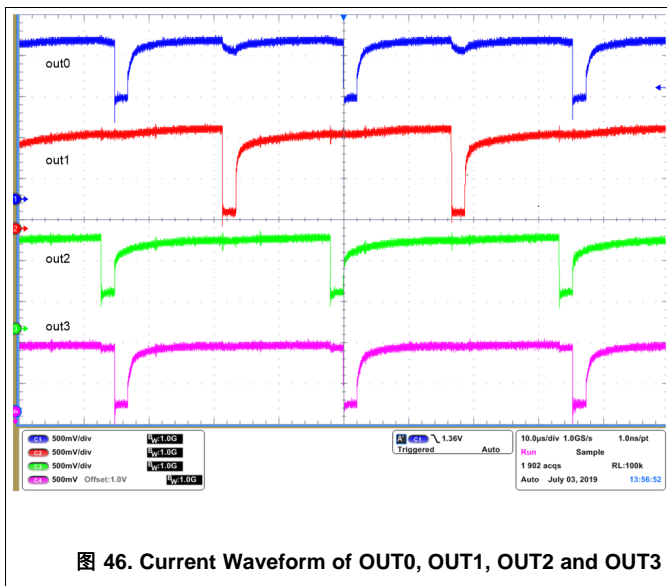

10 Power Supply Recommendations

The device is designed to operate from a V_{VCC} input-voltage supply range from 2.7 V and 5.5 V. This input supply must be well-regulated and able to withstand maximum input current and maintain stable voltage without voltage drop even in a load-transition condition (start-up or rapid intensity change). The resistance of the input supply rail must be low enough that the input-current transient does not cause a drop below a 2.7-V level in the LP50xx V_{VCC} supply voltage.

11 Layout

11.1 Layout Guidelines

To prevent thermal shutdown, the junction temperature, T_J , must be less than $T_{(TSD)}$. If the voltage drop across the output channels is high, the device power dissipation can be large. The LP50xx device has very good thermal performance because of the thermal pad design; however, the PCB layout is also very important to ensure that the device has good thermal performance. Good PCB design can optimize heat transfer, which is essential for the long-term reliability of the device.

Use the following guidelines when designing the device layout:

- Place the $C_{V_{CAP}}$, $C_{V_{CC}}$ and $R_{I_{REF}}$ as close to the device as possible. Also, TI recommends putting the ground plane as [图 48](#) and [图 49](#).
- Maximize the copper coverage on the PCB to increase the thermal conductivity of the board. The major heat flow path from the package to the ambient is through copper on the PCB. Maximum copper density is extremely important when no heat sinks are attached to the PCB on the other side from the package.
- Add as many thermal vias as possible directly under the package ground pad to optimize the thermal conductivity of the board.
- Use either plated-shut or plugged and capped vias for all the thermal vias on both sides of the board to prevent solder voids. To ensure reliability and performance, the solder coverage must be at least 85%.

11.2 Layout Examples



图 48. LP5009 Layout Example

Layout Examples (接下页)

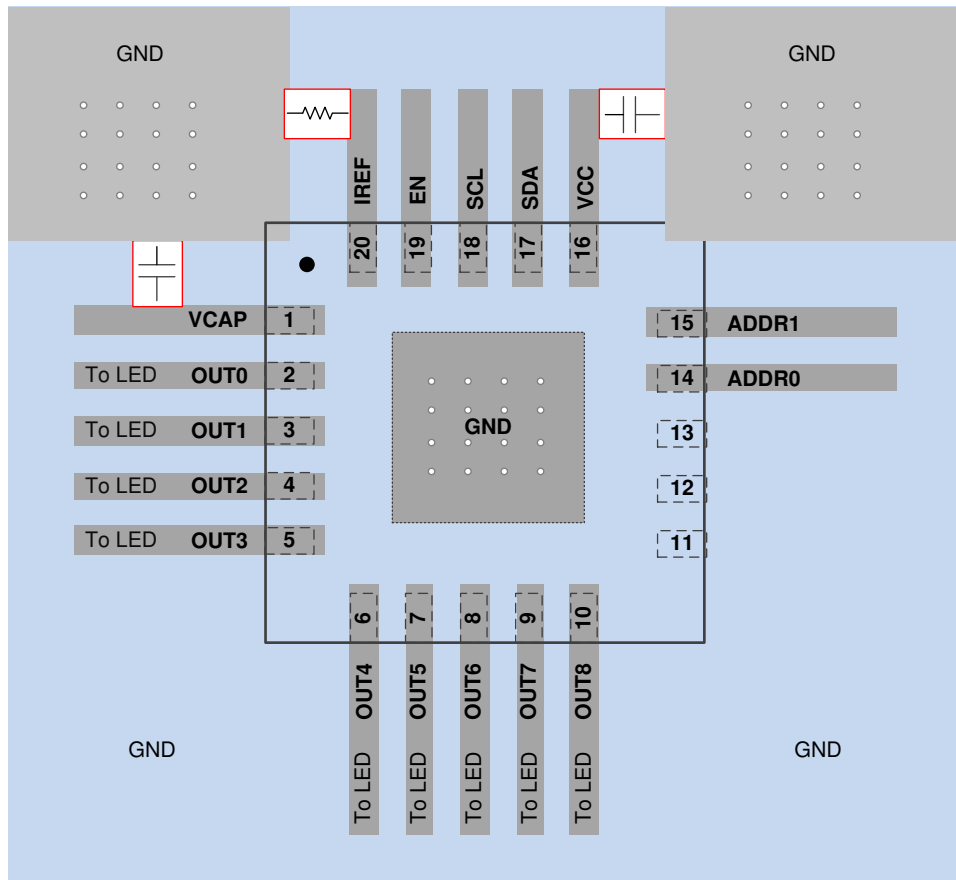

图 49. LP5012 Layout Example

12 器件和文档支持

12.1 相关链接

下表列出了快速访问链接。类别包括技术文档、支持和社区资源、工具和软件，以及立即订购快速访问。

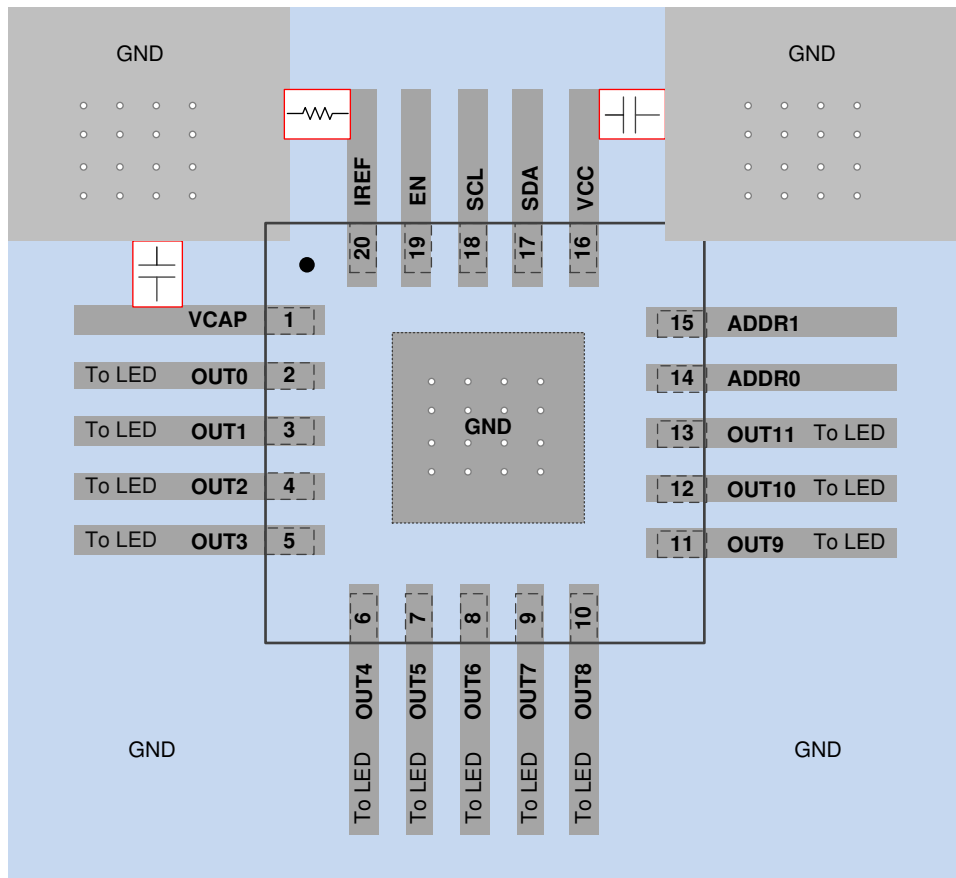
表 30. 相关链接

器件	产品文件夹	立即订购	技术文档	工具与软件	支持和社区
LP5009	单击此处	单击此处	单击此处	单击此处	单击此处
LP5012	单击此处	单击此处	单击此处	单击此处	单击此处

12.2 接收文档更新通知

要接收文档更新通知，请导航至 TI.com.cn 上的器件产品文件夹。单击右上角的 [通知我](#) 进行注册，即可每周接收产品信息更改摘要。有关更改的详细信息，请查看任何已修订文档中包含的修订历史记录。

12.3 社区资源

The following links connect to TI community resources. Linked contents are provided "AS IS" by the respective contributors. They do not constitute TI specifications and do not necessarily reflect TI's views; see TI's [Terms of Use](#).

TI E2E™ Online Community *TI's Engineer-to-Engineer (E2E) Community*. Created to foster collaboration among engineers. At e2e.ti.com, you can ask questions, share knowledge, explore ideas and help solve problems with fellow engineers.

Design Support *TI's Design Support* Quickly find helpful E2E forums along with design support tools and contact information for technical support.

12.4 商标

E2E is a trademark of Texas Instruments.
All other trademarks are the property of their respective owners.

12.5 静电放电警告



ESD 可能会损坏该集成电路。德州仪器 (TI) 建议通过适当的预防措施处理所有集成电路。如果不遵守正确的处理措施和安装程序，可能会损坏集成电路。

ESD 的损坏小至导致微小的性能降级，大至整个器件故障。精密的集成电路可能更容易受到损坏，这是因为非常细微的参数更改都可能会导致器件与其发布的规格不相符。

12.6 Glossary

[SLYZ022](#) — *TI Glossary*.

This glossary lists and explains terms, acronyms, and definitions.

13 机械、封装和可订购信息

以下页面包含机械、封装和可订购信息。这些信息是指定器件的最新可用数据。数据如有变更，恕不另行通知，且不会对此文档进行修订。如需获取此数据表的浏览器版本，请查看左侧的导航面板。

PACKAGING INFORMATION

Orderable Device	Status (1)	Package Type	Package Drawing	Pins	Package Qty	Eco Plan (2)	Lead finish/ Ball material (6)	MSL Peak Temp (3)	Op Temp (°C)	Device Marking (4/5)	Samples
LP5009PWR	ACTIVE	TSSOP	PW	24	2000	RoHS & Green	NIPDAU	Level-2-260C-1 YEAR	-40 to 85	LP5009PWR	Samples
LP5009RUKR	ACTIVE	WQFN	RUK	20	3000	RoHS & Green	NIPDAU	Level-1-260C-UNLIM	-40 to 85	LP5009	Samples
LP5012PWR	ACTIVE	TSSOP	PW	24	2000	RoHS & Green	NIPDAU	Level-2-260C-1 YEAR	-40 to 85	LP5012PWR	Samples
LP5012RUKR	ACTIVE	WQFN	RUK	20	3000	RoHS & Green	NIPDAU	Level-1-260C-UNLIM	-40 to 85	LP5012	Samples

(1) The marketing status values are defined as follows:

ACTIVE: Product device recommended for new designs.

LIFEBUY: TI has announced that the device will be discontinued, and a lifetime-buy period is in effect.

NRND: Not recommended for new designs. Device is in production to support existing customers, but TI does not recommend using this part in a new design.

PREVIEW: Device has been announced but is not in production. Samples may or may not be available.

OBSOLETE: TI has discontinued the production of the device.

(2) **RoHS:** TI defines "RoHS" to mean semiconductor products that are compliant with the current EU RoHS requirements for all 10 RoHS substances, including the requirement that RoHS substance do not exceed 0.1% by weight in homogeneous materials. Where designed to be soldered at high temperatures, "RoHS" products are suitable for use in specified lead-free processes. TI may reference these types of products as "Pb-Free".

RoHS Exempt: TI defines "RoHS Exempt" to mean products that contain lead but are compliant with EU RoHS pursuant to a specific EU RoHS exemption.

Green: TI defines "Green" to mean the content of Chlorine (Cl) and Bromine (Br) based flame retardants meet JS709B low halogen requirements of <=1000ppm threshold. Antimony trioxide based flame retardants must also meet the <=1000ppm threshold requirement.

(3) MSL, Peak Temp. - The Moisture Sensitivity Level rating according to the JEDEC industry standard classifications, and peak solder temperature.

(4) There may be additional marking, which relates to the logo, the lot trace code information, or the environmental category on the device.

(5) Multiple Device Markings will be inside parentheses. Only one Device Marking contained in parentheses and separated by a "-" will appear on a device. If a line is indented then it is a continuation of the previous line and the two combined represent the entire Device Marking for that device.

(6) Lead finish/Ball material - Orderable Devices may have multiple material finish options. Finish options are separated by a vertical ruled line. Lead finish/Ball material values may wrap to two lines if the finish value exceeds the maximum column width.

Important Information and Disclaimer:The information provided on this page represents TI's knowledge and belief as of the date that it is provided. TI bases its knowledge and belief on information provided by third parties, and makes no representation or warranty as to the accuracy of such information. Efforts are underway to better integrate information from third parties. TI has taken and

continues to take reasonable steps to provide representative and accurate information but may not have conducted destructive testing or chemical analysis on incoming materials and chemicals. TI and TI suppliers consider certain information to be proprietary, and thus CAS numbers and other limited information may not be available for release.

In no event shall TI's liability arising out of such information exceed the total purchase price of the TI part(s) at issue in this document sold by TI to Customer on an annual basis.

TAPE AND REEL INFORMATION

QUADRANT ASSIGNMENTS FOR PIN 1 ORIENTATION IN TAPE

*All dimensions are nominal

Device	Package Type	Package Drawing	Pins	SPQ	Reel Diameter (mm)	Reel Width W1 (mm)	A0 (mm)	B0 (mm)	K0 (mm)	P1 (mm)	W (mm)	Pin1 Quadrant
LP5009PWR	TSSOP	PW	24	2000	330.0	16.4	6.95	8.3	1.6	8.0	16.0	Q1
LP5009RUKR	WQFN	RUK	20	3000	330.0	12.4	3.3	3.3	1.1	8.0	12.0	Q2
LP5012PWR	TSSOP	PW	24	2000	330.0	16.4	6.95	8.3	1.6	8.0	16.0	Q1
LP5012RUKR	WQFN	RUK	20	3000	330.0	12.4	3.3	3.3	1.1	8.0	12.0	Q2

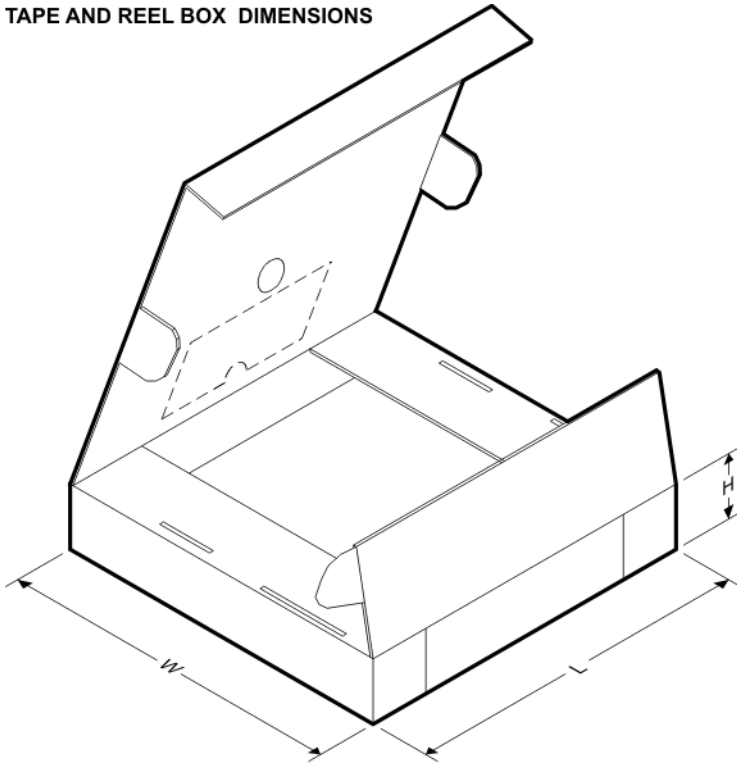
TAPE AND REEL BOX DIMENSIONS

*All dimensions are nominal

Device	Package Type	Package Drawing	Pins	SPQ	Length (mm)	Width (mm)	Height (mm)
LP5009PWR	TSSOP	PW	24	2000	853.0	449.0	35.0
LP5009RUKR	WQFN	RUK	20	3000	367.0	367.0	35.0
LP5012PWR	TSSOP	PW	24	2000	853.0	449.0	35.0
LP5012RUKR	WQFN	RUK	20	3000	367.0	367.0	35.0

PW0024A

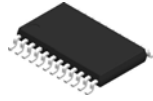

PACKAGE OUTLINE

TSSOP - 1.2 mm max height

SMALL OUTLINE PACKAGE

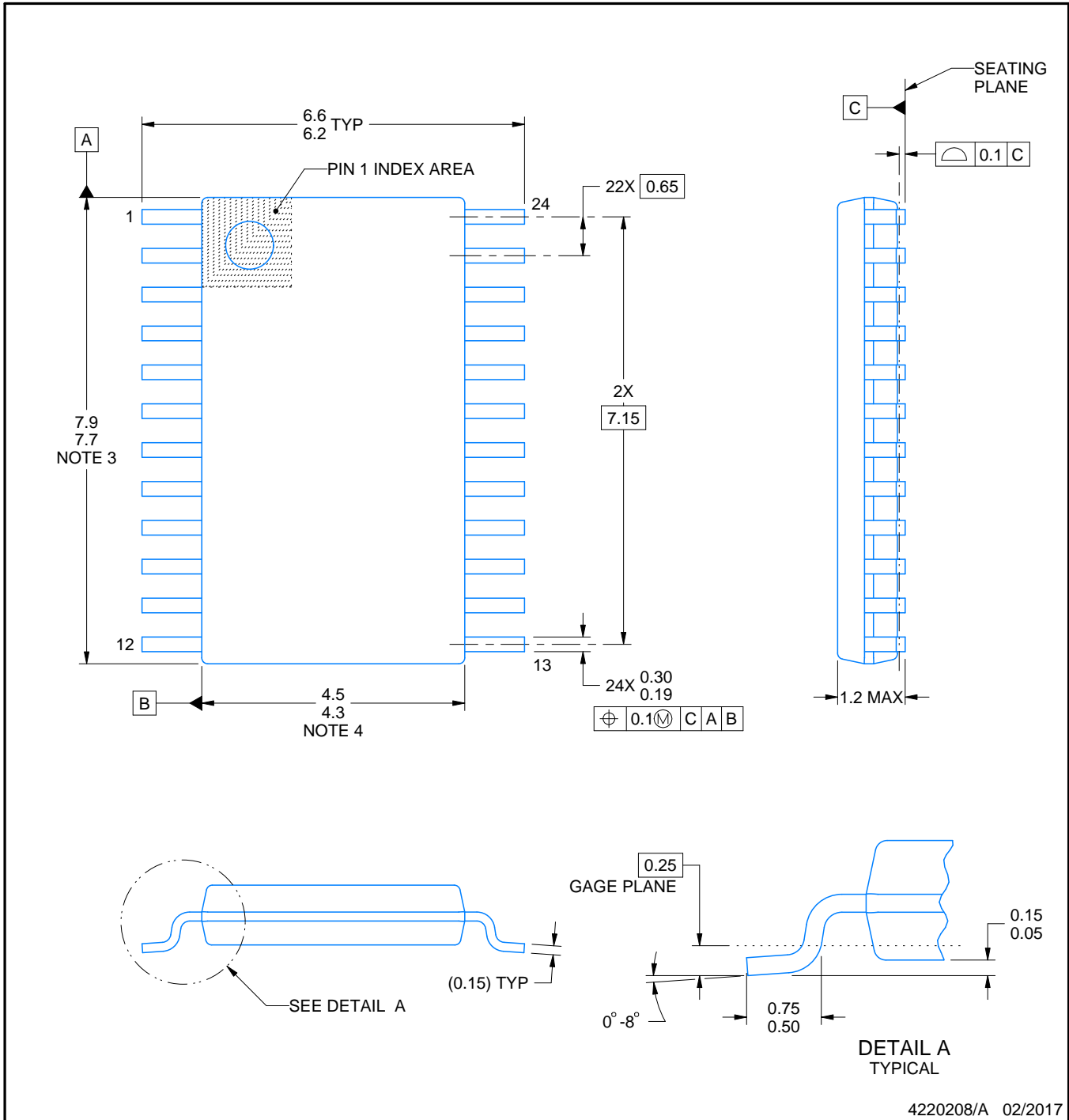

4220208/A 02/2017

NOTES:

1. All linear dimensions are in millimeters. Any dimensions in parenthesis are for reference only. Dimensioning and tolerancing per ASME Y14.5M.
2. This drawing is subject to change without notice.
3. This dimension does not include mold flash, protrusions, or gate burrs. Mold flash, protrusions, or gate burrs shall not exceed 0.15 mm per side.
4. This dimension does not include interlead flash. Interlead flash shall not exceed 0.25 mm per side.
5. Reference JEDEC registration MO-153.

EXAMPLE BOARD LAYOUT

PW0024A

TSSOP - 1.2 mm max height

SMALL OUTLINE PACKAGE

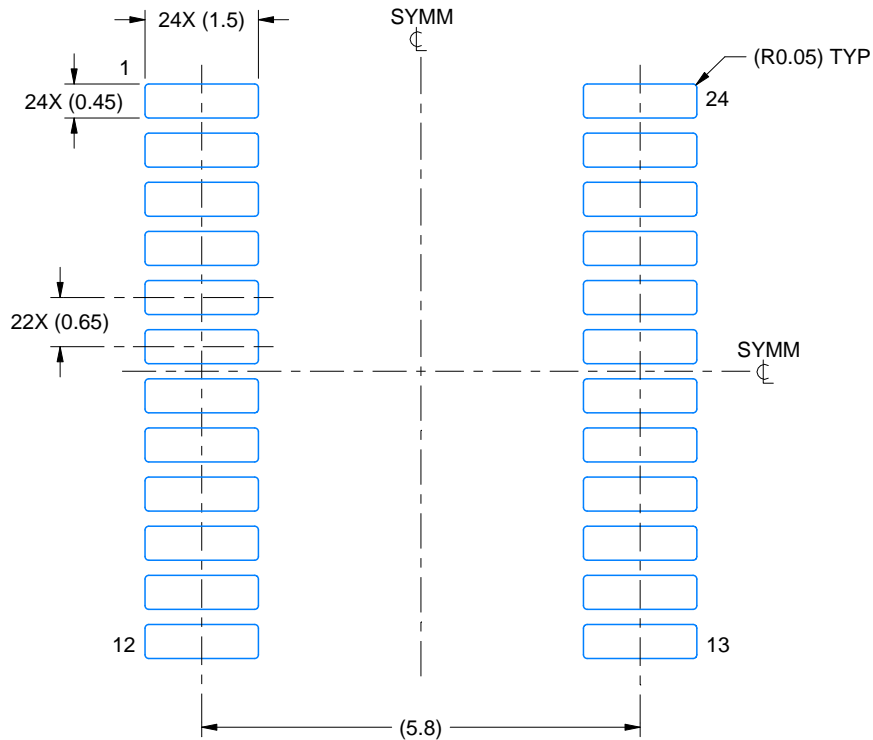

LAND PATTERN EXAMPLE
EXPOSED METAL SHOWN
SCALE: 10X

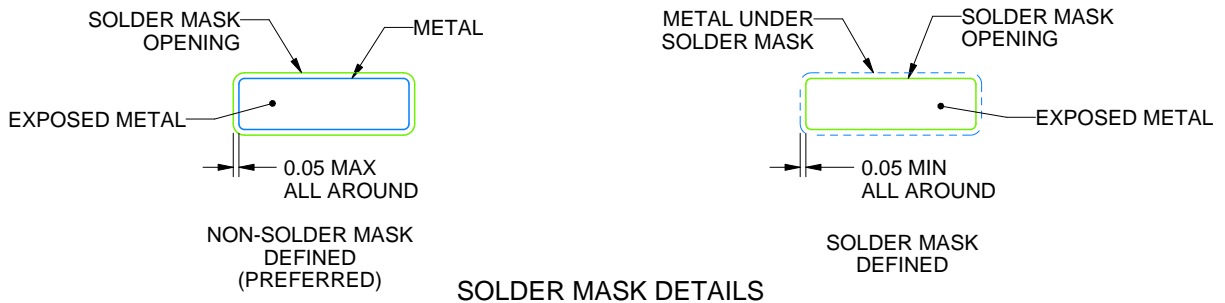

SOLDER MASK DETAILS

4220208/A 02/2017

NOTES: (continued)

- 6. Publication IPC-7351 may have alternate designs.
- 7. Solder mask tolerances between and around signal pads can vary based on board fabrication site.

EXAMPLE STENCIL DESIGN

PW0024A

TSSOP - 1.2 mm max height

SMALL OUTLINE PACKAGE

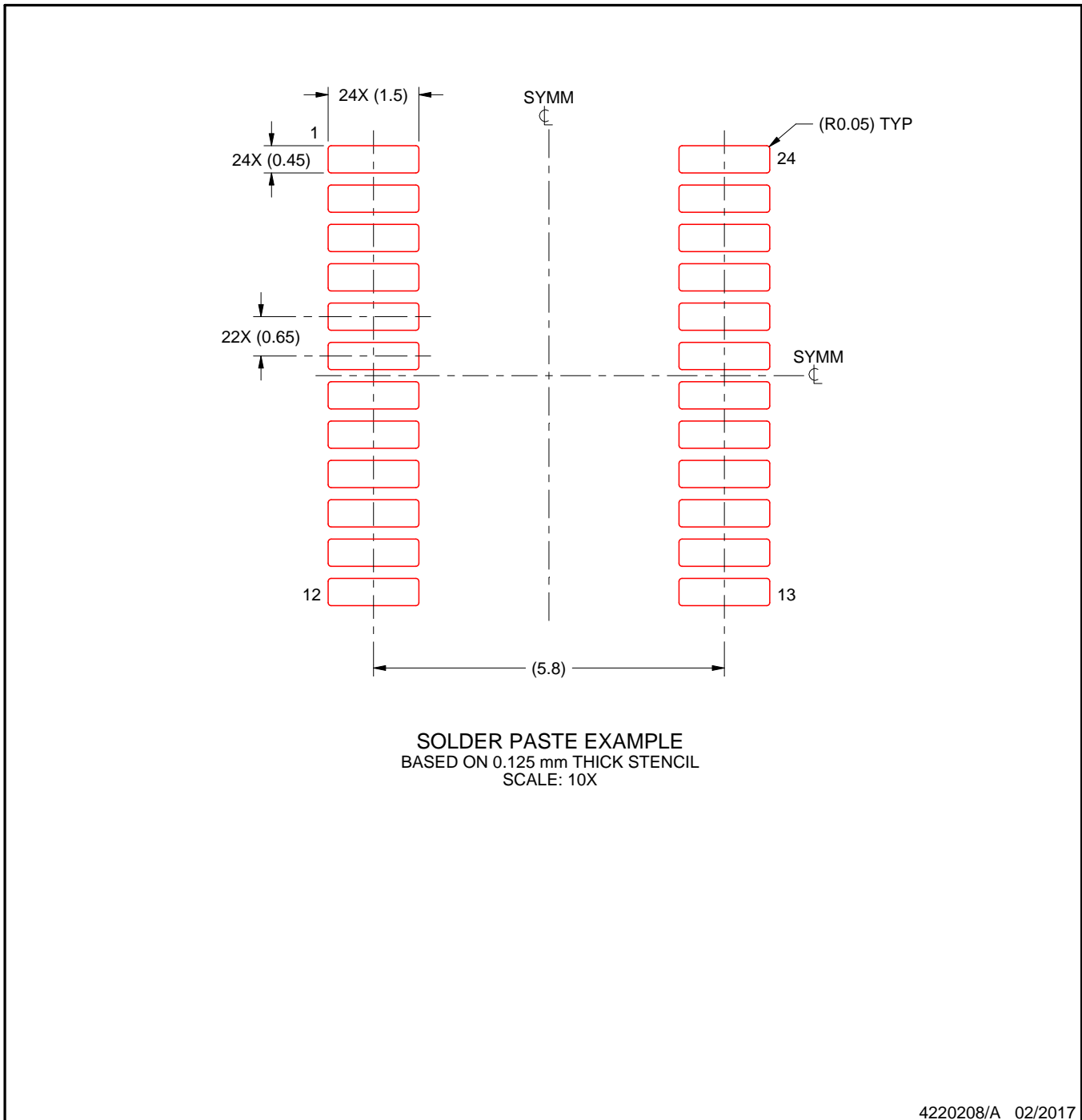

NOTES: (continued)

8. Laser cutting apertures with trapezoidal walls and rounded corners may offer better paste release. IPC-7525 may have alternate design recommendations.
9. Board assembly site may have different recommendations for stencil design.

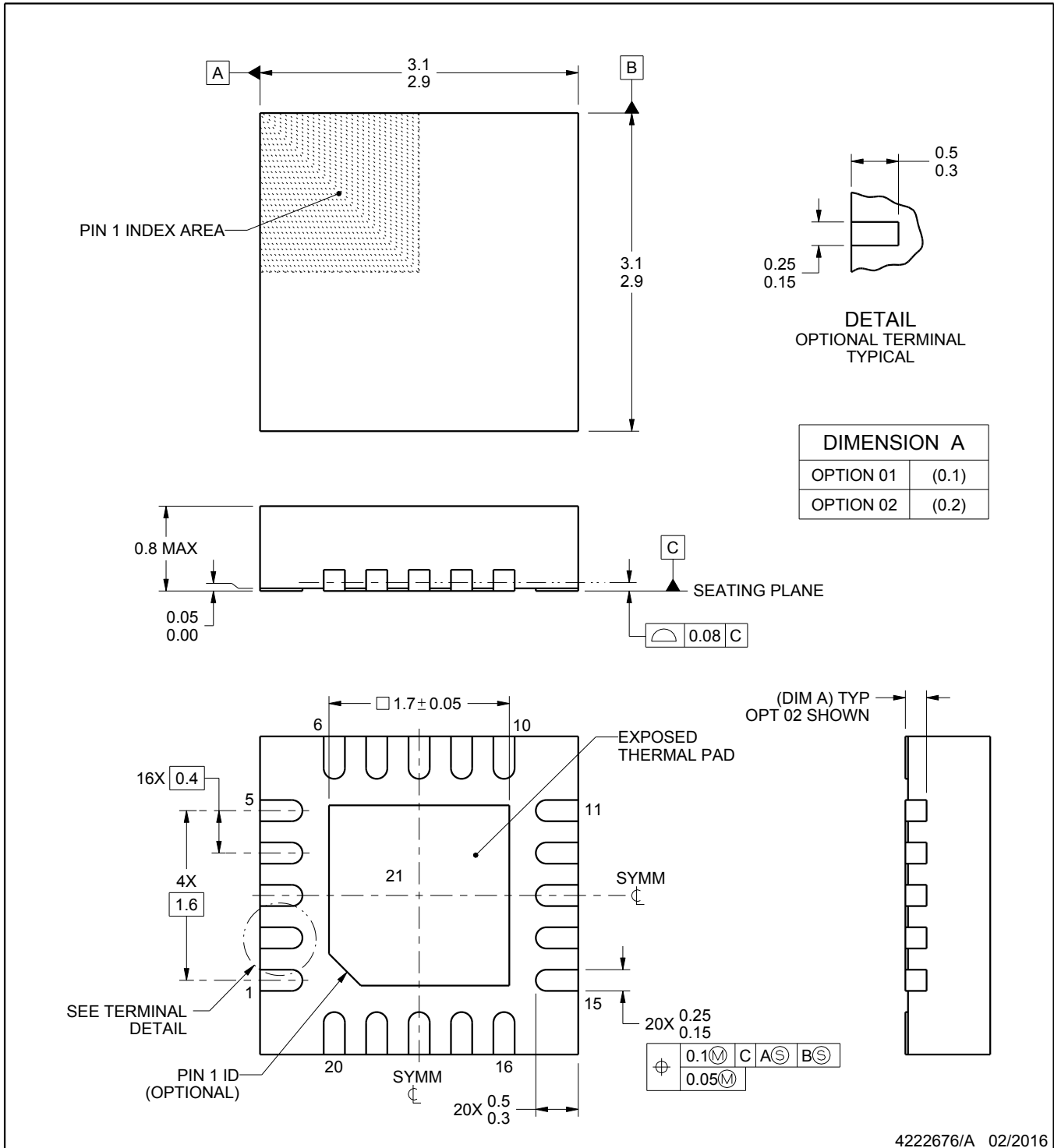
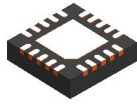

4222676/A 02/2016

NOTES:

1. All linear dimensions are in millimeters. Any dimensions in parenthesis are for reference only. Dimensioning and tolerancing per ASME Y14.5M.
2. This drawing is subject to change without notice.
3. The package thermal pad must be soldered to the printed circuit board for thermal and mechanical performance.

EXAMPLE BOARD LAYOUT

RUK0020B

WQFN - 0.8 mm max height

PLASTIC QUAD FLATPACK - NO LEAD

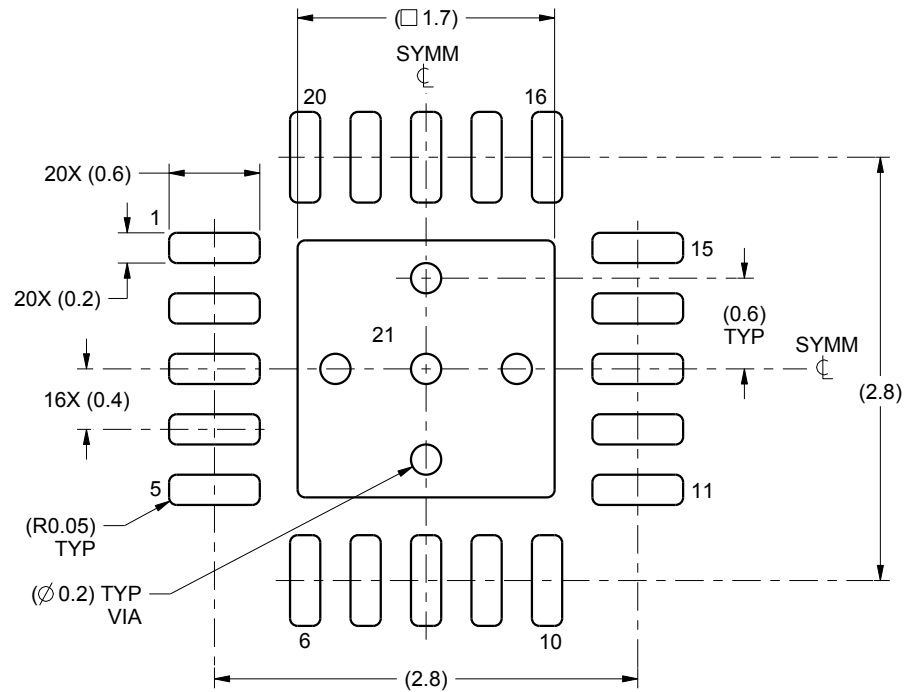

LAND PATTERN EXAMPLE
SCALE:20X

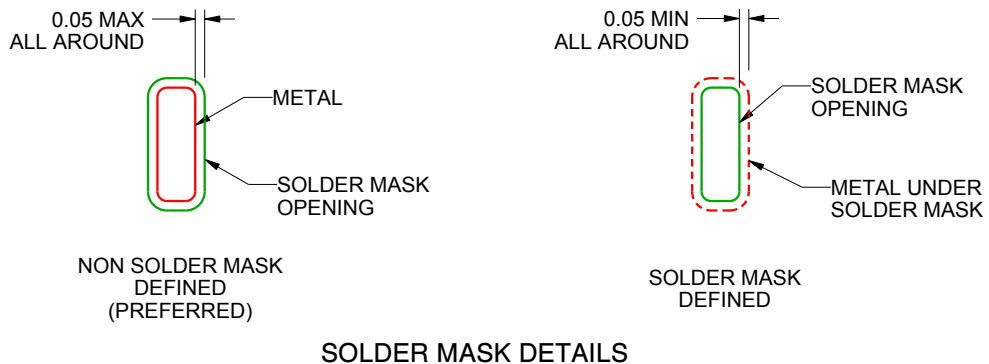

SOLDER MASK DETAILS

4222676/A 02/2016

NOTES: (continued)

4. This package is designed to be soldered to a thermal pad on the board. For more information, see Texas Instruments literature number SLUA271 (www.ti.com/lit/sluea271).
5. Vias are optional depending on application, refer to device data sheet. If any vias are implemented, refer to their locations shown on this view. It is recommended that vias under paste be filled, plugged or tented.

重要声明和免责声明

TI“按原样”提供技术和可靠性数据（包括数据表）、设计资源（包括参考设计）、应用或其他设计建议、网络工具、安全信息和其他资源，不保证没有瑕疵且不做任何明示或暗示的担保，包括但不限于对适销性、某特定用途方面的适用性或不侵犯任何第三方知识产权的暗示担保。

这些资源可供使用 TI 产品进行设计的熟练开发人员使用。您将自行承担以下全部责任：(1) 针对您的应用选择合适的 TI 产品，(2) 设计、验证并测试您的应用，(3) 确保您的应用满足相应标准以及任何其他功能安全、信息安全、监管或其他要求。

这些资源如有变更，恕不另行通知。TI 授权您仅可将这些资源用于研发本资源所述的 TI 产品的应用。严禁对这些资源进行其他复制或展示。您无权使用任何其他 TI 知识产权或任何第三方知识产权。您应全额赔偿因在这些资源的使用中对 TI 及其代表造成的任何索赔、损害、成本、损失和债务，TI 对此概不负责。

TI 提供的产品受 [TI 的销售条款](#) 或 [ti.com](#) 上其他适用条款/TI 产品随附的其他适用条款的约束。TI 提供这些资源并不会扩展或以其他方式更改 TI 针对 TI 产品发布的适用的担保或担保免责声明。

TI 反对并拒绝您可能提出的任何其他或不同的条款。

邮寄地址：Texas Instruments, Post Office Box 655303, Dallas, Texas 75265
Copyright © 2021，德州仪器 (TI) 公司