

SN5545xB, SN7545xB Dual-Peripheral Drivers for High-Current, High-Speed Switching

1 Features

- Characterized for Use to 300 mA
- High-Voltage Outputs up to 30 V
- No Output Latch-Up at 20 V (After Conducting 300 mA)
- High-Speed Switching
- Open-Collector Outputs
- Circuit Flexibility for Varied Applications
- TTL-Compatible Diode-Clamped Inputs
- Standard Supply Voltages

2 Applications

- High-Speed Logic Buffers
- Power Drivers
- Lamp Drivers
- LED Drivers
- Line Drivers
- Memory Drivers

3 Description

The SN5545xB and SN7545xB devices are dual-peripheral drivers designed for use in systems that employ TTL logic. This family is functionally interchangeable with and replaces the SN75450 family and the SN75450A family devices manufactured previously. The speed of the devices is equal to that of the SN75450 family, and the parts are designed to ensure freedom from latch-up. Diode-clamped inputs simplify circuit design.

The SNx5451B, SNx5452B, SNx5453B, and SNx5454B devices are dual peripheral AND, NAND, OR, and NOR drivers, respectively (assuming positive logic), with the output of the logic gates internally connected to the bases of the npn output transistors.

The SN5545xB drivers are characterized for operation over the full military range of -55°C to 125°C . The SN7545xB drivers are characterized for operation from 0°C to 70°C .

Device Information⁽¹⁾

PART NUMBER	PACKAGE	BODY SIZE (NOM)
SN7545xBP	PDIP (8)	9.81 mm x 6.35 mm
SN7545xBD	SOIC (8)	4.90 mm x 3.90 mm
SN7545xBPS	SO (8)	6.20 mm x 5.30 mm
SN5545xBJG	CDIP (8)	9.60 mm x 6.67 mm
SN5545xBFK	LCCC (20)	8.89 mm x 8.89 mm

(1) For all available packages, see the orderable addendum at the end of the data sheet.

SN75451B Logic Diagram

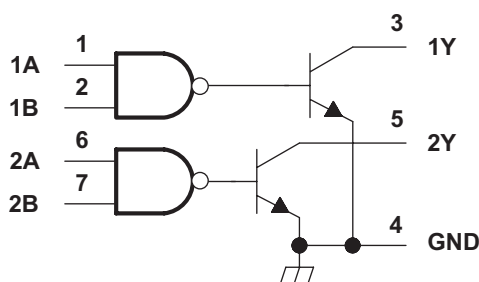

Copyright © 2016 Texas Instruments Incorporated



Table of Contents

1 Features	1	9.3 Feature Description	10
2 Applications	1	9.4 Device Functional Modes	10
3 Description	1	10 Application and Implementation	13
4 Revision History	2	10.1 Application Information	13
5 Device Comparison Table	3	10.2 Typical Application	13
6 Pin Configuration and Functions	3	11 Power Supply Recommendations	14
7 Specifications	4	12 Layout	14
7.1 Absolute Maximum Ratings	4	12.1 Layout Guidelines	14
7.2 Recommended Operating Conditions	4	12.2 Layout Example	14
7.3 Thermal Information	4	13 Device and Documentation Support	15
7.4 Electrical Characteristics	5	13.1 Related Links	15
7.5 Switching Characteristics, $V_{CC} = 5\text{ V}$, $T_A = 25^\circ\text{C}$	5	13.2 Receiving Notification of Documentation Updates	15
7.6 Dissipation Ratings	5	13.3 Community Resources	15
7.7 Typical Characteristics	6	13.4 Trademarks	15
8 Parameter Measurement Information	6	13.5 Electrostatic Discharge Caution	15
9 Detailed Description	9	13.6 Glossary	15
9.1 Overview	9	14 Mechanical, Packaging, and Orderable Information	15
9.2 Functional Block Diagrams	9		

4 Revision History

Changes from Revision C (May 2016) to Revision D	Page
• Replaced image <i>SN75451B Logic Diagram</i>	1

Changes from Revision B (January 1999) to Revision C	Page
• Added <i>ESD Ratings</i> table, <i>Feature Description</i> section, <i>Device Functional Modes</i> , <i>Application and Implementation</i> section, <i>Power Supply Recommendations</i> section, <i>Layout</i> section, <i>Device and Documentation Support</i> section, and <i>Mechanical, Packaging, and Orderable Information</i> section.	1

5 Device Comparison Table

DEVICE	LOGIC OF COMPLETE CIRCUIT	OPERATING FREE AIR TEMPERATURE RANGE
SN55451B	AND	–55°C to 125°C
SN55452B	NAND	–55°C to 125°C
SN55453B	OR	–55°C to 125°C
SN55454B	NOR	–55°C to 125°C
SN75451B	AND	0°C to 70°C
SN75452B	NAND	0°C to 70°C
SN75453B	OR	0°C to 70°C
SN75454B	NOR	0°C to 70°C

6 Pin Configuration and Functions

JG, D, P, or PS Package
8-Pin CDIP, SOIC, PDIP, or SO
Top View

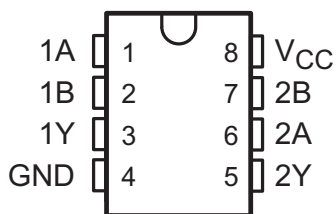

FK Package
20-Pin LCCC
Top View

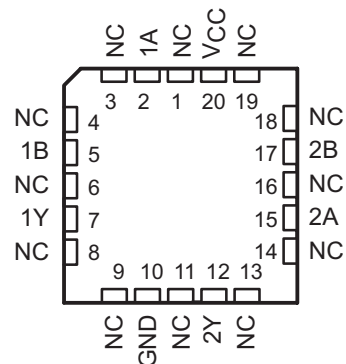

NC – No internal connection

Pin Functions

NAME	PIN		I/O	DESCRIPTION
	CDIP, SOIC, PDIP, SO	LCCC		
1A	1	2	I	Channel 1 Logic Input A
1B	2	5	I	Channel 1 Logic Input B
1Y	3	7	O	Channel 1 Driver
2A	6	15	I	Channel 2 Logic Input A
2B	7	17	I	Channel 2 Logic Input B
2Y	5	12	O	Channel 2 Driver
GND	4	10	—	Ground
NC	—	1, 3, 4, 6, 8, 9, 11, 13, 14, 16, 18, 19	—	No Internal Connection
VCC	8	20	—	Supply Voltage

7 Specifications

7.1 Absolute Maximum Ratings

over operating free-air temperature range (unless otherwise noted)⁽¹⁾

		MIN	MAX	UNIT	
V _{CC}	Supply voltage, (see ⁽²⁾)		7	V	
V _I	Input voltage		5.5	V	
	Inter-emitter voltage (see Note ⁽³⁾)		5.5	V	
V _O	Off-state output voltage		30	V	
I _{OK}	Continuous collector or output current, (see Note ⁽⁴⁾)		400	mA	
	Peak collector or output current, II (tw ≤ 10 ms, duty cycle ≤ 50%, see Note ⁽⁵⁾)		500	mA	
	Continuous total power dissipation	See Dissipation Ratings			
T _A	Operating free-air temperature	SN5545xB	–55	125	°C
		SN7545xB	0	70	
	Case temperature for 60 seconds	SN5545xB FK package		260	°C
	Lead temperature 1,6 mm (1/16 inch) from case for 60 seconds	SN5545xB JG package		100	°C
	Lead temperature 1,6 mm (1/16 inch) from case for 10 seconds	SN7545xB D or P package		260	°C
T _J	Operating virtual junction temperature		150	°C	
T _{stg}	Storage temperature	–65	150	°C	

- (1) Stresses beyond those listed under *Absolute Maximum Ratings* may cause permanent damage to the device. These are stress ratings only, which do not imply functional operation of the device at these or any other conditions beyond those indicated under *Recommended Operating Conditions*. Exposure to absolute-maximum-rated conditions for extended periods may affect device reliability.
- (2) Voltage values are with respect to network GND, unless otherwise specified.
- (3) This is the voltage between two emitters of a multiple-emitter transistor.
- (4) This value applies when the base-emitter resistance (RBE) is equal to or less than 500 Ω.
- (5) Both halves of these dual circuits may conduct rated current simultaneously; however, power dissipation averaged over a short time interval must fall within the continuous dissipation rating.

7.2 Recommended Operating Conditions

over operating free-air temperature range (unless otherwise noted)

		MIN	NOM	MAX	UNIT	
V _{CC}	Supply voltage	SN5545xB	4.5	5	5.5	V
		SN7545xB	4.75	5	5.25	
V _{IH}	High-level input voltage	2			V	
V _{IL}	Low-level input voltage			0.8	V	
T _A	Operating free-air temperature	SN5545xB	–50	125	°C	
		SN7545xB	0	70		

7.3 Thermal Information

THERMAL METRIC ⁽¹⁾	SN7545xB			UNIT	
	D (SOIC)	P (PDIP)	PS (SO)		
	8 PINS	8 PINS	8 PINS		
R _{θJA}	Junction-to-ambient thermal resistance	122.2	63.7	119.6	°C/W
R _{θJC(top)}	Junction-to-case (top) thermal resistance	68.4	53.6	71.5	°C/W
R _{θJB}	Junction-to-board thermal resistance	62.4	40.8	68.7	°C/W
ψ _{JT}	Junction-to-top characterization parameter	23.2	31.1	31.6	°C/W
ψ _{JB}	Junction-to-board characterization parameter	62.0	40.8	67.7	°C/W

- (1) For more information about traditional and new thermal metrics, see the [Semiconductor and IC Package Thermal Metrics](#) application report.

7.4 Electrical Characteristics

over operating free-air temperature range (unless otherwise noted)

PARAMETER		TEST CONDITIONS	MIN	TYP	MAX	UNIT
V_{IK}	Input clamp voltage	$V_{CC} = \text{MIN}$, $I_I = -12 \text{ mA}$		-1.2	-1.5	V
V_{OL}	Low-level output voltage	$V_{CC} = \text{MIN}$, $V_{IL} = 0.8 \text{ V}$, $I_{OL} = 100 \text{ mA}$	SN5545xB	0.25	0.5	V
			SN7545xB	0.25	0.4	
		$V_{CC} = \text{MIN}$, $V_{IL} = 0.8 \text{ V}$, $I_{OL} = 300 \text{ mA}$	SN5545xB	0.5	0.8	
			SN7545xB	0.5	0.7	
I_{OH}	High-level output current	$V_{CC} = \text{MIN}$, $V_{IH} = \text{MIN}$, $V_{OH} = 30 \text{ V}$	SN5545xB		300	μA
			SN7545xB		100	
I_I	Input current at maximum input voltage	$V_{CC} = \text{MAX}$, $V_I = 5.5 \text{ V}$			1	mA
I_{IH}	High-level input current	$V_{CC} = \text{MAX}$, $V_I = 2.4 \text{ V}$			40	μA
I_{IL}	Low-level input current	$V_{CC} = \text{MAX}$, $V_I = 0.4 \text{ V}$		-1	-1.6	mA
I_{CCH}	Supply current, outputs high	$V_{CC} = \text{MAX}$, $V_I = 5 \text{ V}$	SNx5451B	7	11	mA
			SNx5453B	8	11	
		$V_{CC} = \text{MAX}$, $V_I = 0 \text{ V}$	SNx5452B	11	14	
			SNx5454B	13	17	
I_{CCL}	Supply current, outputs low	$V_{CC} = \text{MAX}$, $V_I = 0 \text{ V}$	SNx5451B	52	65	mA
			SNx5453B	54	68	
		$V_{CC} = \text{MAX}$, $V_I = 5 \text{ V}$	SNx5452B	56	71	
			SNx5454B	61	79	

7.5 Switching Characteristics, $V_{CC} = 5 \text{ V}$, $T_A = 25^\circ\text{C}$

over operating free-air temperature range (unless otherwise noted)

PARAMETER		TEST CONDITIONS ⁽¹⁾	MIN	TYP ⁽²⁾	MAX	UNIT
t_{PLH}	Propagation delay time, low-to-high-level output	$I_O \approx 200 \text{ mA}$, $C_L = 15 \text{ pF}$, $R_L = 50 \Omega$, L See Figure 2	SNx5451B, SNx5453B	18	25	ns
			SNx5452B	26	35	
			SNx5454B	27	35	
			SNx5451B, SNx5453B	18	25	
t_{PHL}	Propagation delay time, high-to-low-level output	$I_O \approx 200 \text{ mA}$, $C_L = 15 \text{ pF}$, $R_L = 50 \Omega$, L See Figure 2	SNx5452B, SNx5454B	24	35	
			SNx5451B, SNx5453B	18	25	
t_{TLH}	Transition time, low-to-high-level output	$I_O \approx 200 \text{ mA}$, $C_L = 15 \text{ pF}$, $R_L = 50 \Omega$, L See Figure 2		5	8	
t_{THL}	Transition time, high-to-low-level output	$I_O \approx 200 \text{ mA}$, $C_L = 15 \text{ pF}$, $R_L = 50 \Omega$, L See Figure 2		7	12	
V_{OH}	High level output voltage after switching	$V_S = 20 \text{ V}$, $I_O 9 \text{ 300 mA}$, See Figure 2	SN5545xB	$V_S - 6.5$		mV
			SN7545xB	$V_S - 6.5$		

(1) For conditions shown as MIN or MAX, use the appropriate value specified under recommended operating conditions.

 (2) All typical values are at $V_{CC} = 5 \text{ V}$, $T_A = 25^\circ\text{C}$.

7.6 Dissipation Ratings

PACKAGE	$T_A \leq 25^\circ\text{C}$ POWER RATING	DERATING FACTOR ABOVE $T_A = 25^\circ\text{C}$	$T_A = 70^\circ\text{C}$ POWER RATING	$T_A = 125^\circ\text{C}$ POWER RATING
D	725 mW	5.8 mW/ $^\circ\text{C}$	464	—
FK	1375 mW	11.0 mW/ $^\circ\text{C}$	880	275 mW
JG	1050 mW	8.4 mW/ $^\circ\text{C}$	672	210 mW
P	1000 mW	8.0 mW/ $^\circ\text{C}$	640	—

7.7 Typical Characteristics

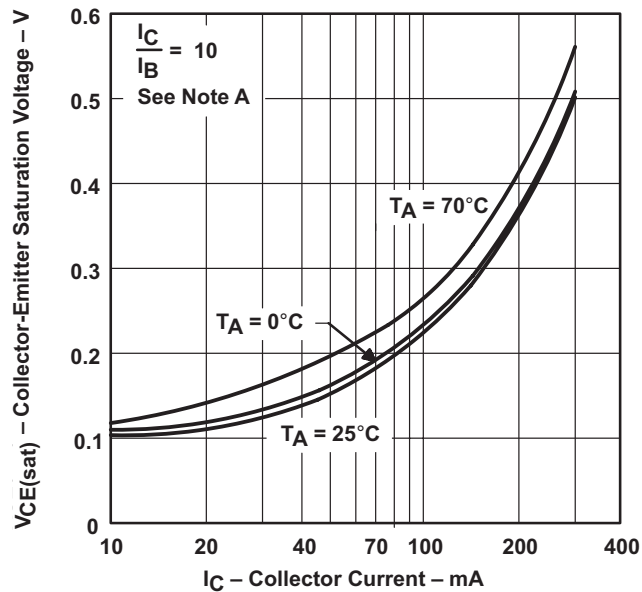

NOTE A: These parameters must be measured using pulse techniques, $t_w = 300 \mu\text{s}$, duty cycle $\leq 2\%$.

Figure 1. Transistor Collector-Emitter Saturation Voltage vs Collector Current

8 Parameter Measurement Information

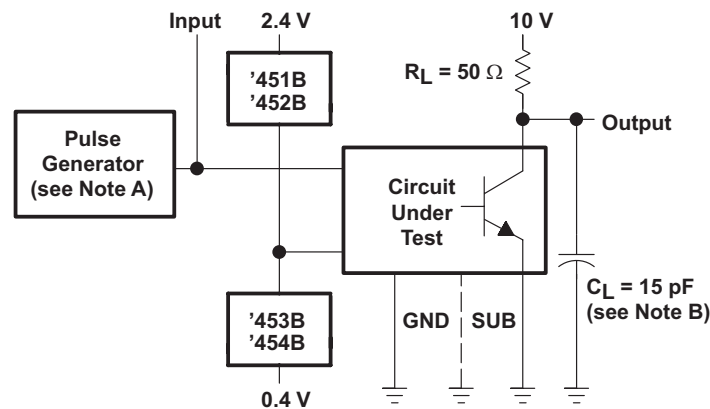

- A. The pulse generator has the following characteristics: $\text{PRR} \leq 1 \text{ MHz}$, $Z_O = 50 \Omega$.
- B. C_L includes probe and jig capacitance.

Figure 2. Test Circuit, Complete Drivers

Parameter Measurement Information (continued)

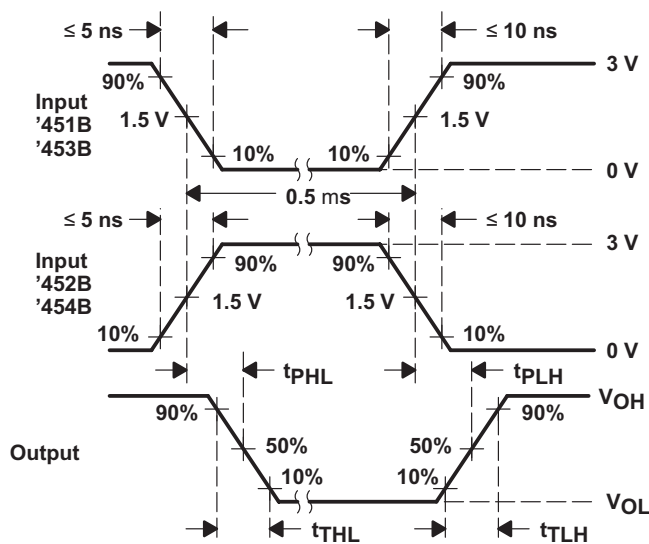

- A. The pulse generator has the following characteristics: PRR \leq 1 MHz, $Z_O = 50 \Omega$.
- B. C_L includes probe and jig capacitance.

Figure 3. Waveforms, Complete Drivers

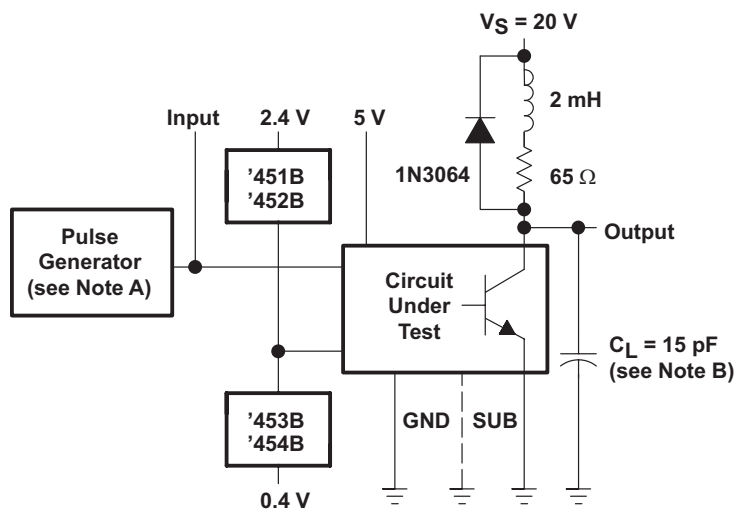

- A. The pulse generator has the following characteristics: PRR \leq 12.5 kHz, $Z_O = 50 \Omega$.
- B. C_L includes probe and jig capacitance.

Figure 4. Test Circuit for Latch-Up Test of Complete Drivers

Parameter Measurement Information (continued)

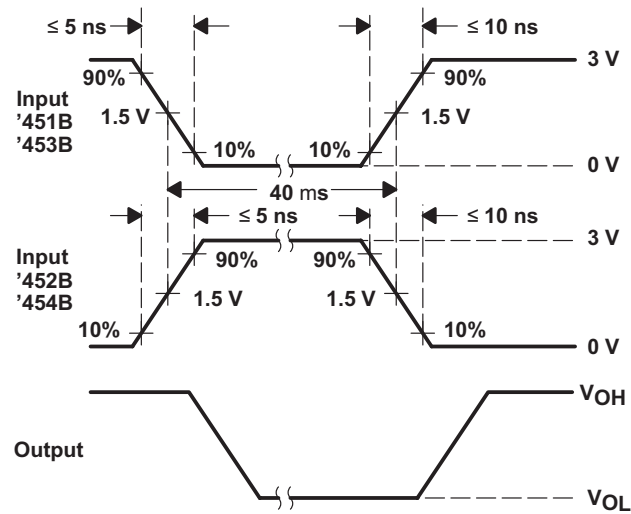

- A. The pulse generator has the following characteristics: PRR $\leq 12.5\text{ kHz}$, $Z_O = 50\ \Omega$.
- B. C_L includes probe and jig capacitance.

Figure 5. Voltage Waveforms for Latch-Up Test of Complete Drivers

9 Detailed Description

9.1 Overview

The SN7545xB and SN5545xB devices provide dual-output drivers with AND, NAND, NOR, or OR logic inputs. If each logic input is set to the appropriate voltage level, then the output driver will turn on, pulling the driver to ground and allowing current to flow.

9.2 Functional Block Diagrams

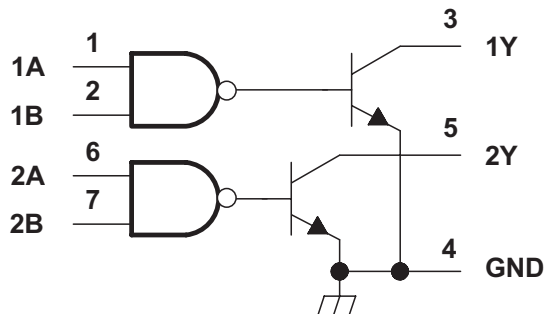

Copyright © 2016 Texas Instruments Incorporated

Figure 6. SNx5451B Logic Diagram (Positive Logic)

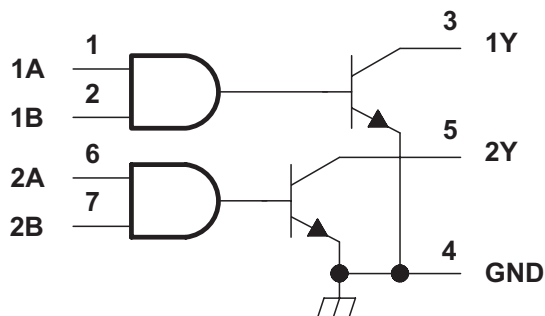

Copyright © 2016 Texas Instruments Incorporated

Figure 7. SNx5452B Logic Diagram (Positive Logic)

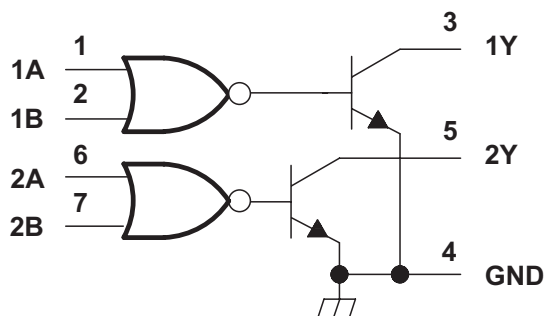

Copyright © 2016 Texas Instruments Incorporated

Figure 8. SNx5453B Logic Diagram (Positive Logic)

Functional Block Diagrams (continued)

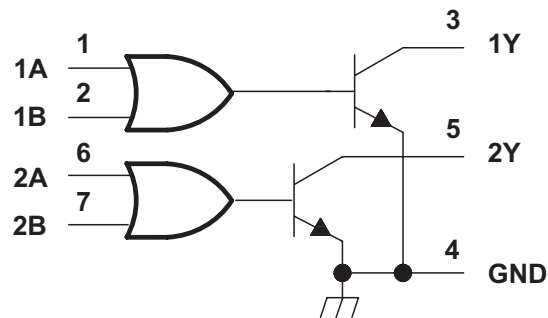

Copyright © 2016 Texas Instruments Incorporated

Figure 9. SNx5454B Logic Diagram (Positive Logic)

9.3 Feature Description

The SNx5451B devices allow for high current driving up to 300 mA. This family of devices have AND, NAND, OR, or NOR input logic gates to allow for a wide variety of applications. The SN7545xB devices are rated for a commercial temperature range of 0°C to 70°C, and the SN5545xB devices are rated for a military temperature range of –65°C to 125°C.

9.4 Device Functional Modes

Table 1, Table 2, Table 3, and Table 4 list the functional modes of the SNx545xB.



Figure 10. SNx5451B Logic Symbol

Table 1. SNx5451B Function Table

A	B	Y ⁽¹⁾
L	L	L (on state)
L	H	L (on state)
H	L	L (on state)
H	H	H (off state)

(1) Positive logic: $Y = AB$ or $\text{NOT}(\bar{A} + \bar{B})$

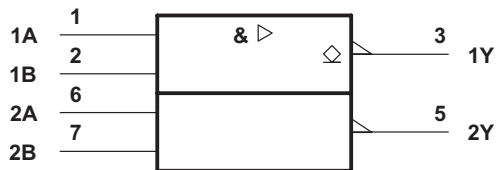

Figure 11. SNx5452B Logic Symbol

Table 2. SNx5452B Function Table

A	B	Y (1)
L	L	H (off state)
L	H	H (off state)
H	L	H (off state)
H	H	L (on state)

(1) Positive logic: $Y = \overline{AB}$ or $\overline{A} + \overline{B}$

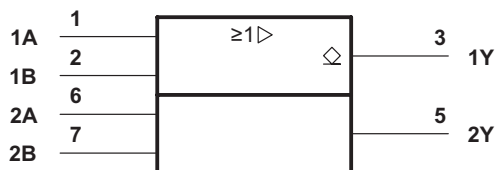

Figure 12. SNx5453B Logic Symbol

Table 3. SNx5453B Function Table

A	B	Y (1)
L	L	L (on state)
L	H	H (off state)
H	L	H (off state)
H	H	H (off state)

(1) Positive logic: $Y = AB$ or $\text{NOT}(\overline{A} + \overline{B})$

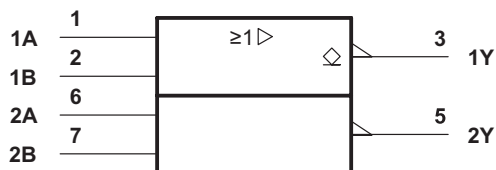

Figure 13. SNx5454B Logic Symbol

Table 4. SNx5454B Function Table

A	B	Y (1)
L	L	H (off state)
L	H	L (on state)
H	L	L (on state)
H	H	L (on state)

(1) Positive logic: $Y = \overline{A+B}$ or $\overline{A} \overline{B}$

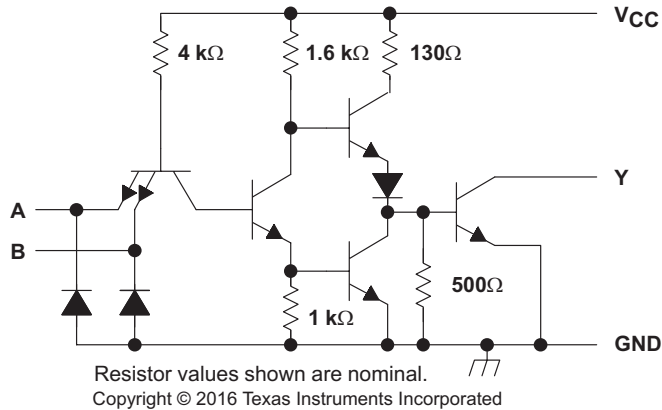

Figure 14. SNx5451B Schematic (Each Driver)

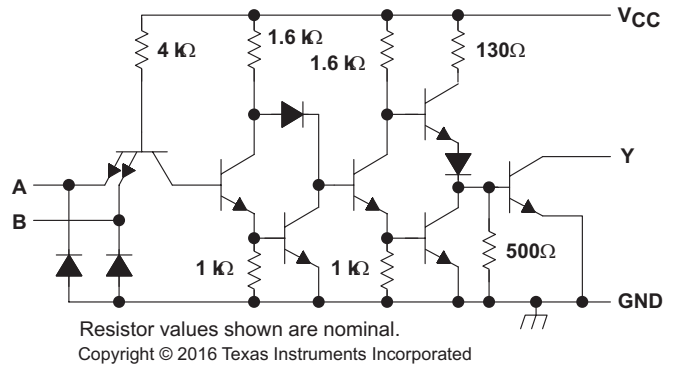

Figure 15. SNx5452B Schematic (Each Driver)

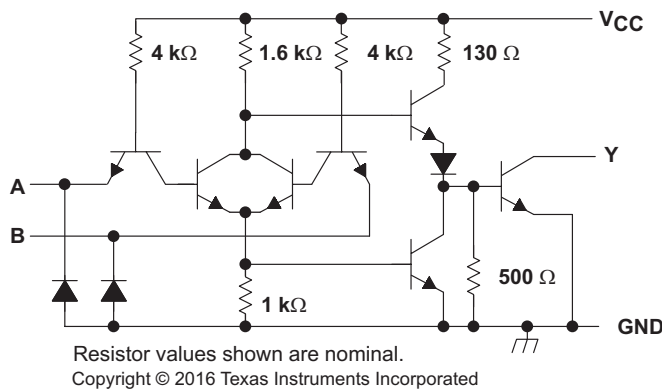

Figure 16. SNx5453B Schematic (Each Driver)

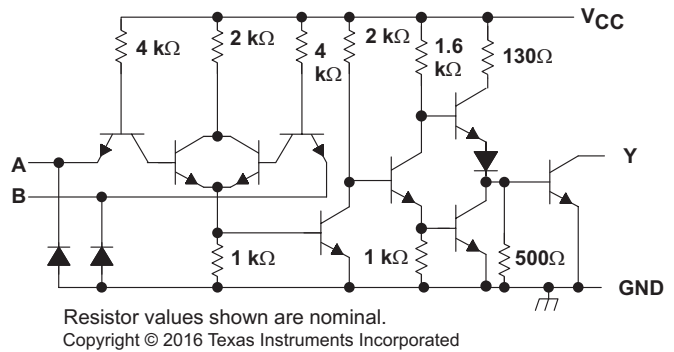

Figure 17. SNx5454B Schematic (Each Driver)

10 Application and Implementation

NOTE

Information in the following applications sections is not part of the TI component specification, and TI does not warrant its accuracy or completeness. TI's customers are responsible for determining suitability of components for their purposes. Customers should validate and test their design implementation to confirm system functionality.

10.1 Application Information

Typically the SN75451B device drives a high-voltage or high-current peripheral from an MCU or logic device that cannot tolerate these conditions. The following design is a common application of the SN75451B device, driving an LED using one channel and a high voltage peripheral using the other. In this configuration, the LED will turn on whenever the high voltage peripheral is on.

10.2 Typical Application

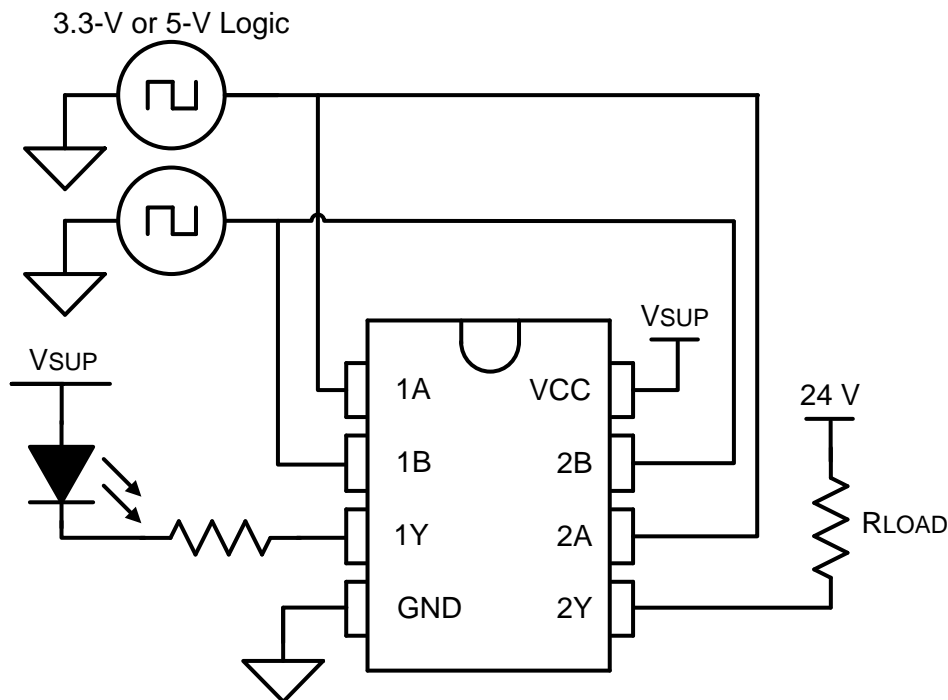

Copyright © 2016, Texas Instruments Incorporated

Figure 18. SN75451B Driving an LED and a High Voltage Peripheral

10.2.1 Design Requirements

Each of the inputs to the logic gate should never float. If one of the inputs is floating, then the logic gate could be in an unknown state. Be sure to connect ground or V_{CC} to any unused input channels.

10.2.2 Detailed Design Procedure

- Recommended Input Conditions:
 - For specified high and low levels, see V_{IH} and V_{IL} in [Recommended Operating Conditions](#).
 - The input voltage must not exceed the V_I specified in [Absolute Maximum Ratings](#).
- Recommended Output Conditions:
 - It is recommended that the load current not exceed 300 mA.
 - The load current must never exceed the I_{OK} noted in [Absolute Maximum Ratings](#).

Typical Application (continued)

10.2.3 Application Curves

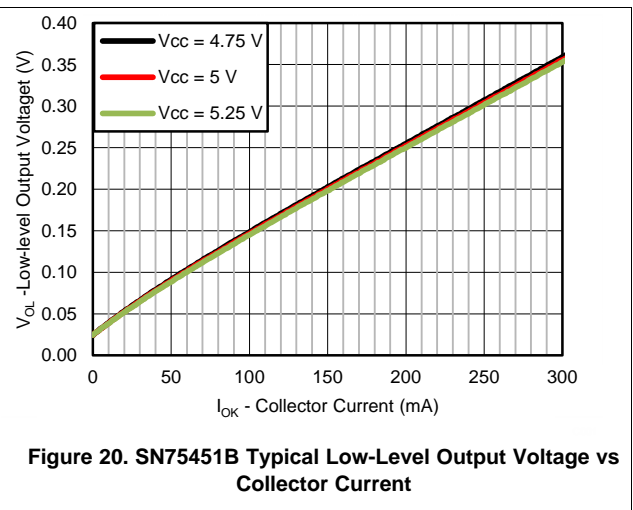
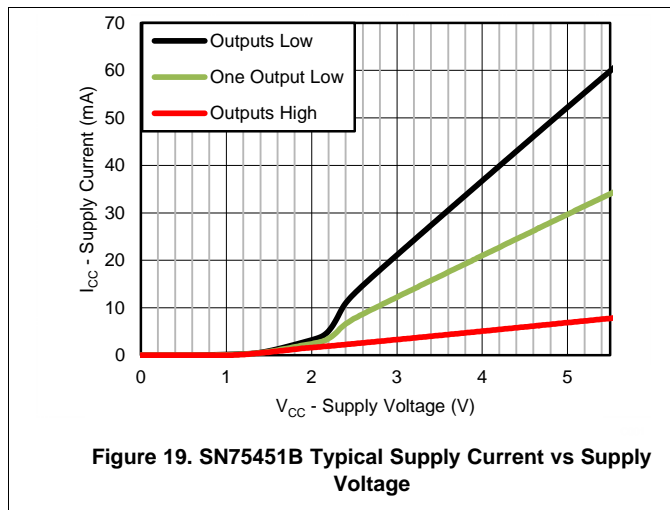

11 Power Supply Recommendations

The power supply can be any voltage between the minimum and maximum supply voltage rating located in [Recommended Operating Conditions](#). The V_{CC} pin should have a bypass capacitor to prevent power disturbance. A 0.1- μF capacitor is suitable for this device.

12 Layout

12.1 Layout Guidelines

Thin traces can be used on the input due to the low-current logic that is used to drive the SNx545xB devices. Take care to separate the input channels to eliminate crosstalk. These traces are recommended for the output to be able to drive high currents. Be sure to connect ground or V_{CC} to any unused input channels, and use a bypass capacitor on the V_{CC} pin to prevent any power glitches.

12.2 Layout Example

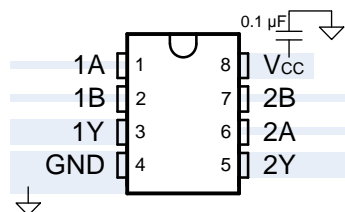

Figure 21. SN75451BD Layout

13 Device and Documentation Support

13.1 Related Links

The table below lists quick access links. Categories include technical documents, support and community resources, tools and software, and quick access to sample or buy.

Table 5. Related Links

PARTS	PRODUCT FOLDER	ORDER NOW	TECHNICAL DOCUMENTS	TOOLS & SOFTWARE	SUPPORT & COMMUNITY
SN55451B	Click here	Click here	Click here	Click here	Click here
SN55452B	Click here	Click here	Click here	Click here	Click here
SN55453B	Click here	Click here	Click here	Click here	Click here
SN55454B	Click here	Click here	Click here	Click here	Click here
SN75451B	Click here	Click here	Click here	Click here	Click here
SN75452B	Click here	Click here	Click here	Click here	Click here
SN75453B	Click here	Click here	Click here	Click here	Click here
SN75454B	Click here	Click here	Click here	Click here	Click here

13.2 Receiving Notification of Documentation Updates

To receive notification of documentation updates, navigate to the device product folder on ti.com. In the upper right corner, click on *Alert me* to register and receive a weekly digest of any product information that has changed. For change details, review the revision history included in any revised document.

13.3 Community Resources

The following links connect to TI community resources. Linked contents are provided "AS IS" by the respective contributors. They do not constitute TI specifications and do not necessarily reflect TI's views; see TI's [Terms of Use](#).

TI E2E™ Online Community *TI's Engineer-to-Engineer (E2E) Community*. Created to foster collaboration among engineers. At e2e.ti.com, you can ask questions, share knowledge, explore ideas and help solve problems with fellow engineers.

Design Support *TI's Design Support* Quickly find helpful E2E forums along with design support tools and contact information for technical support.

13.4 Trademarks

E2E is a trademark of Texas Instruments.
All other trademarks are the property of their respective owners.

13.5 Electrostatic Discharge Caution



These devices have limited built-in ESD protection. The leads should be shorted together or the device placed in conductive foam during storage or handling to prevent electrostatic damage to the MOS gates.

13.6 Glossary

[SLYZ022](#) — *TI Glossary*.

This glossary lists and explains terms, acronyms, and definitions.

14 Mechanical, Packaging, and Orderable Information

The following pages include mechanical, packaging, and orderable information. This information is the most current data available for the designated devices. This data is subject to change without notice and revision of this document. For browser-based versions of this data sheet, refer to the left-hand navigation.

PACKAGING INFORMATION

Orderable Device	Status (1)	Package Type	Package Drawing	Pins	Package Qty	Eco Plan (2)	Lead finish/ Ball material (6)	MSL Peak Temp (3)	Op Temp (°C)	Device Marking (4/5)	Samples
5962-9563301Q2A	ACTIVE	LCCC	FK	20	1	Non-RoHS & Green	SNPB	N / A for Pkg Type	-55 to 125	5962-9563301Q2A SNJ55 453BFK	Samples
5962-9563301QPA	ACTIVE	CDIP	JG	8	1	Non-RoHS & Green	SNPB	N / A for Pkg Type	-55 to 125	9563301QPA SNJ55453B	Samples
77049012A	ACTIVE	LCCC	FK	20	1	Non-RoHS & Green	SNPB	N / A for Pkg Type	-55 to 125	77049012A SNJ55 452BFK	Samples
7704901PA	ACTIVE	CDIP	JG	8	1	Non-RoHS & Green	SNPB	N / A for Pkg Type	-55 to 125	7704901PA SNJ55452B	Samples
77049022A	ACTIVE	LCCC	FK	20	1	Non-RoHS & Green	SNPB	N / A for Pkg Type	-55 to 125	77049022A SNJ55 451BFK	Samples
7704902PA	ACTIVE	CDIP	JG	8	1	Non-RoHS & Green	SNPB	N / A for Pkg Type	-55 to 125	7704902PA SNJ55451B	Samples
JM38510/12902BPA	ACTIVE	CDIP	JG	8	1	Non-RoHS & Green	SNPB	N / A for Pkg Type	-55 to 125	JM38510 /12902BPA	Samples
JM38510/12903BPA	ACTIVE	CDIP	JG	8	1	Non-RoHS & Green	SNPB	N / A for Pkg Type	-55 to 125	JM38510 /12903BPA	Samples
JM38510/12905BPA	ACTIVE	CDIP	JG	8	1	Non-RoHS & Green	SNPB	N / A for Pkg Type	-55 to 125	JM38510 /12905BPA	Samples
M38510/12902BPA	ACTIVE	CDIP	JG	8	1	Non-RoHS & Green	SNPB	N / A for Pkg Type	-55 to 125	JM38510 /12902BPA	Samples
M38510/12903BPA	ACTIVE	CDIP	JG	8	1	Non-RoHS & Green	SNPB	N / A for Pkg Type	-55 to 125	JM38510 /12903BPA	Samples
M38510/12905BPA	ACTIVE	CDIP	JG	8	1	Non-RoHS & Green	SNPB	N / A for Pkg Type	-55 to 125	JM38510 /12905BPA	Samples
SN55451BJG	ACTIVE	CDIP	JG	8	50	Non-RoHS & Green	SNPB	N / A for Pkg Type	-55 to 125	SN55451BJG	Samples
SN55452BJG	ACTIVE	CDIP	JG	8	1	Non-RoHS & Green	SNPB	N / A for Pkg Type	-55 to 125	SN55452BJG	Samples
SN55453BJG	ACTIVE	CDIP	JG	8	1	Non-RoHS & Green	SNPB	N / A for Pkg Type	-55 to 125	SN55453BJG	Samples

Orderable Device	Status (1)	Package Type	Package Drawing	Pins	Package Qty	Eco Plan (2)	Lead finish/ Ball material (6)	MSL Peak Temp (3)	Op Temp (°C)	Device Marking (4/5)	Samples
SN55454BJG	ACTIVE	CDIP	JG	8	1	Non-RoHS & Green	SNPB	N / A for Pkg Type	-55 to 125	SN55454BJG	Samples
SN75451BD	ACTIVE	SOIC	D	8	75	RoHS & Green	NIPDAU	Level-1-260C-UNLIM	0 to 70	75451B	Samples
SN75451BDE4	ACTIVE	SOIC	D	8	75	RoHS & Green	NIPDAU	Level-1-260C-UNLIM	0 to 70	75451B	Samples
SN75451BDR	ACTIVE	SOIC	D	8	2500	RoHS & Green	NIPDAU	Level-1-260C-UNLIM	0 to 70	75451B	Samples
SN75451BDRE4	ACTIVE	SOIC	D	8	2500	RoHS & Green	NIPDAU	Level-1-260C-UNLIM	0 to 70	75451B	Samples
SN75451BDRG4	ACTIVE	SOIC	D	8	2500	RoHS & Green	NIPDAU	Level-1-260C-UNLIM	0 to 70	75451B	Samples
SN75451BP	ACTIVE	PDIP	P	8	50	RoHS & Green	NIPDAU	N / A for Pkg Type	0 to 70	SN75451BP	Samples
SN75451BPE4	ACTIVE	PDIP	P	8	50	RoHS & Green	NIPDAU	N / A for Pkg Type	0 to 70	SN75451BP	Samples
SN75451BPS	ACTIVE	SO	PS	8	80	RoHS & Green	NIPDAU	Level-1-260C-UNLIM		A451B	Samples
SN75451BPSR	ACTIVE	SO	PS	8	2000	RoHS & Green	NIPDAU	Level-1-260C-UNLIM	0 to 70	A451B	Samples
SN75452BD	ACTIVE	SOIC	D	8	75	RoHS & Green	NIPDAU	Level-1-260C-UNLIM	0 to 70	75452B	Samples
SN75452BDE4	ACTIVE	SOIC	D	8	75	RoHS & Green	NIPDAU	Level-1-260C-UNLIM	0 to 70	75452B	Samples
SN75452BDR	ACTIVE	SOIC	D	8	2500	RoHS & Green	NIPDAU	Level-1-260C-UNLIM	0 to 70	75452B	Samples
SN75452BDRE4	ACTIVE	SOIC	D	8	2500	RoHS & Green	NIPDAU	Level-1-260C-UNLIM	0 to 70	75452B	Samples
SN75452BDRG4	ACTIVE	SOIC	D	8	2500	RoHS & Green	NIPDAU	Level-1-260C-UNLIM	0 to 70	75452B	Samples
SN75452BP	ACTIVE	PDIP	P	8	50	RoHS & Green	NIPDAU	N / A for Pkg Type	0 to 70	SN75452BP	Samples
SN75452BPE4	ACTIVE	PDIP	P	8	50	RoHS & Green	NIPDAU	N / A for Pkg Type	0 to 70	SN75452BP	Samples
SN75452BPS	ACTIVE	SO	PS	8	80	RoHS & Green	NIPDAU	Level-1-260C-UNLIM		A452B	Samples
SN75452BPSR	ACTIVE	SO	PS	8	2000	RoHS & Green	NIPDAU	Level-1-260C-UNLIM	0 to 70	A452B	Samples
SN75452BPSRG4	ACTIVE	SO	PS	8	2000	RoHS & Green	NIPDAU	Level-1-260C-UNLIM	0 to 70	A452B	Samples
SN75453BD	ACTIVE	SOIC	D	8	75	RoHS & Green	NIPDAU	Level-1-260C-UNLIM	0 to 70	75453B	Samples

Orderable Device	Status (1)	Package Type	Package Drawing	Pins	Package Qty	Eco Plan (2)	Lead finish/ Ball material (6)	MSL Peak Temp (3)	Op Temp (°C)	Device Marking (4/5)	Samples
SN75453BDR	ACTIVE	SOIC	D	8	2500	RoHS & Green	NIPDAU	Level-1-260C-UNLIM	0 to 70	75453B	Samples
SN75453BDRG4	ACTIVE	SOIC	D	8	2500	RoHS & Green	NIPDAU	Level-1-260C-UNLIM	0 to 70	75453B	Samples
SN75453BP	ACTIVE	PDIP	P	8	50	RoHS & Green	NIPDAU	N / A for Pkg Type	0 to 70	SN75453BP	Samples
SN75453BPE4	ACTIVE	PDIP	P	8	50	RoHS & Green	NIPDAU	N / A for Pkg Type	0 to 70	SN75453BP	Samples
SN75453BPSR	ACTIVE	SO	PS	8	2000	RoHS & Green	NIPDAU	Level-1-260C-UNLIM	0 to 70	A453B	Samples
SN75454BD	ACTIVE	SOIC	D	8	75	RoHS & Green	NIPDAU	Level-1-260C-UNLIM	0 to 70	75454B	Samples
SN75454BDR	ACTIVE	SOIC	D	8	2500	RoHS & Green	NIPDAU	Level-1-260C-UNLIM	0 to 70	75454B	Samples
SN75454BP	ACTIVE	PDIP	P	8	50	RoHS & Green	NIPDAU	N / A for Pkg Type	0 to 70	SN75454BP	Samples
SN75454BPE4	ACTIVE	PDIP	P	8	50	RoHS & Green	NIPDAU	N / A for Pkg Type	0 to 70	SN75454BP	Samples
SN75454BPSR	ACTIVE	SO	PS	8	2000	RoHS & Green	NIPDAU	Level-1-260C-UNLIM	0 to 70	A454B	Samples
SNJ55451BFBK	ACTIVE	LCCC	FK	20	1	Non-RoHS & Green	SNPB	N / A for Pkg Type	-55 to 125	77049022A SNJ55 451BFBK	Samples
SNJ55451BJG	ACTIVE	CDIP	JG	8	1	Non-RoHS & Green	SNPB	N / A for Pkg Type	-55 to 125	7704902PA SNJ55451B	Samples
SNJ55452BFBK	ACTIVE	LCCC	FK	20	1	Non-RoHS & Green	SNPB	N / A for Pkg Type	-55 to 125	77049012A SNJ55 452BFBK	Samples
SNJ55452BJG	ACTIVE	CDIP	JG	8	1	Non-RoHS & Green	SNPB	N / A for Pkg Type	-55 to 125	7704901PA SNJ55452B	Samples
SNJ55453BFBK	ACTIVE	LCCC	FK	20	1	Non-RoHS & Green	SNPB	N / A for Pkg Type	-55 to 125	5962- 9563301Q2A SNJ55 453BFBK	Samples
SNJ55453BJG	ACTIVE	CDIP	JG	8	1	Non-RoHS & Green	SNPB	N / A for Pkg Type	-55 to 125	9563301QPA SNJ55453B	Samples
SNJ55454BJG	ACTIVE	CDIP	JG	8	1	Non-RoHS & Green	SNPB	N / A for Pkg Type	-55 to 125	SNJ55 454BJG	Samples

(1) The marketing status values are defined as follows:

ACTIVE: Product device recommended for new designs.

LIFEBUY: TI has announced that the device will be discontinued, and a lifetime-buy period is in effect.

NRND: Not recommended for new designs. Device is in production to support existing customers, but TI does not recommend using this part in a new design.

PREVIEW: Device has been announced but is not in production. Samples may or may not be available.

OBSOLETE: TI has discontinued the production of the device.

(2) **RoHS:** TI defines "RoHS" to mean semiconductor products that are compliant with the current EU RoHS requirements for all 10 RoHS substances, including the requirement that RoHS substance do not exceed 0.1% by weight in homogeneous materials. Where designed to be soldered at high temperatures, "RoHS" products are suitable for use in specified lead-free processes. TI may reference these types of products as "Pb-Free".

RoHS Exempt: TI defines "RoHS Exempt" to mean products that contain lead but are compliant with EU RoHS pursuant to a specific EU RoHS exemption.

Green: TI defines "Green" to mean the content of Chlorine (Cl) and Bromine (Br) based flame retardants meet JS709B low halogen requirements of ≤ 1000 ppm threshold. Antimony trioxide based flame retardants must also meet the ≤ 1000 ppm threshold requirement.

(3) MSL, Peak Temp. - The Moisture Sensitivity Level rating according to the JEDEC industry standard classifications, and peak solder temperature.

(4) There may be additional marking, which relates to the logo, the lot trace code information, or the environmental category on the device.

(5) Multiple Device Markings will be inside parentheses. Only one Device Marking contained in parentheses and separated by a "~" will appear on a device. If a line is indented then it is a continuation of the previous line and the two combined represent the entire Device Marking for that device.

(6) Lead finish/Ball material - Orderable Devices may have multiple material finish options. Finish options are separated by a vertical ruled line. Lead finish/Ball material values may wrap to two lines if the finish value exceeds the maximum column width.

Important Information and Disclaimer: The information provided on this page represents TI's knowledge and belief as of the date that it is provided. TI bases its knowledge and belief on information provided by third parties, and makes no representation or warranty as to the accuracy of such information. Efforts are underway to better integrate information from third parties. TI has taken and continues to take reasonable steps to provide representative and accurate information but may not have conducted destructive testing or chemical analysis on incoming materials and chemicals. TI and TI suppliers consider certain information to be proprietary, and thus CAS numbers and other limited information may not be available for release.

In no event shall TI's liability arising out of such information exceed the total purchase price of the TI part(s) at issue in this document sold by TI to Customer on an annual basis.

OTHER QUALIFIED VERSIONS OF SN55451B, SN55452B, SN55453B, SN55454B, SN75451B, SN75452B, SN75453B, SN75454B :

● Catalog : [SN75451B](#), [SN75452B](#), [SN75453B](#), [SN75454B](#)

● Military : [SN55451B](#), [SN55452B](#), [SN55453B](#), [SN55454B](#)

NOTE: Qualified Version Definitions:

- Catalog - TI's standard catalog product
- Military - QML certified for Military and Defense Applications

TAPE AND REEL INFORMATION

QUADRANT ASSIGNMENTS FOR PIN 1 ORIENTATION IN TAPE



*All dimensions are nominal

Device	Package Type	Package Drawing	Pins	SPQ	Reel Diameter (mm)	Reel Width W1 (mm)	A0 (mm)	B0 (mm)	K0 (mm)	P1 (mm)	W (mm)	Pin1 Quadrant
SN75451BDR	SOIC	D	8	2500	330.0	12.4	6.4	5.2	2.1	8.0	12.0	Q1
SN75451BPSR	SO	PS	8	2000	330.0	16.4	8.35	6.6	2.4	12.0	16.0	Q1
SN75452BDR	SOIC	D	8	2500	330.0	12.4	6.4	5.2	2.1	8.0	12.0	Q1
SN75452BPSR	SO	PS	8	2000	330.0	16.4	8.35	6.6	2.4	12.0	16.0	Q1
SN75453BDR	SOIC	D	8	2500	330.0	12.4	6.4	5.2	2.1	8.0	12.0	Q1
SN75453BPSR	SO	PS	8	2000	330.0	16.4	8.35	6.6	2.4	12.0	16.0	Q1
SN75454BDR	SOIC	D	8	2500	330.0	12.4	6.4	5.2	2.1	8.0	12.0	Q1
SN75454BPSR	SO	PS	8	2000	330.0	16.4	8.35	6.6	2.4	12.0	16.0	Q1

TAPE AND REEL BOX DIMENSIONS

*All dimensions are nominal

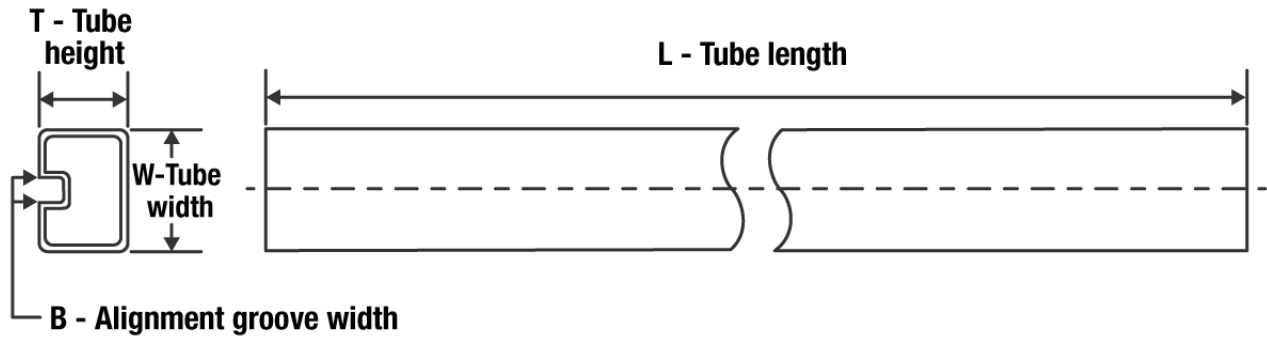
Device	Package Type	Package Drawing	Pins	SPQ	Length (mm)	Width (mm)	Height (mm)
SN75451BDR	SOIC	D	8	2500	340.5	336.1	25.0
SN75451BPSR	SO	PS	8	2000	853.0	449.0	35.0
SN75452BDR	SOIC	D	8	2500	340.5	336.1	25.0
SN75452BPSR	SO	PS	8	2000	853.0	449.0	35.0
SN75453BDR	SOIC	D	8	2500	340.5	336.1	25.0
SN75453BPSR	SO	PS	8	2000	853.0	449.0	35.0
SN75454BDR	SOIC	D	8	2500	340.5	336.1	25.0
SN75454BPSR	SO	PS	8	2000	853.0	449.0	35.0

TUBE

*All dimensions are nominal

Device	Package Name	Package Type	Pins	SPQ	L (mm)	W (mm)	T (μm)	B (mm)
5962-9563301Q2A	FK	LCCC	20	1	506.98	12.06	2030	NA
77049012A	FK	LCCC	20	1	506.98	12.06	2030	NA
77049022A	FK	LCCC	20	1	506.98	12.06	2030	NA
SN75451BD	D	SOIC	8	75	507	8	3940	4.32
SN75451BDE4	D	SOIC	8	75	507	8	3940	4.32
SN75451BP	P	PDIP	8	50	506	13.97	11230	4.32
SN75451BPE4	P	PDIP	8	50	506	13.97	11230	4.32
SN75451BPS	PS	SOP	8	80	530	10.5	4000	4.1
SN75452BD	D	SOIC	8	75	507	8	3940	4.32
SN75452BDE4	D	SOIC	8	75	507	8	3940	4.32
SN75452BP	P	PDIP	8	50	506	13.97	11230	4.32
SN75452BPE4	P	PDIP	8	50	506	13.97	11230	4.32
SN75452BPS	PS	SOP	8	80	530	10.5	4000	4.1
SN75453BD	D	SOIC	8	75	507	8	3940	4.32
SN75453BP	P	PDIP	8	50	506	13.97	11230	4.32
SN75453BPE4	P	PDIP	8	50	506	13.97	11230	4.32
SN75454BD	D	SOIC	8	75	507	8	3940	4.32
SN75454BP	P	PDIP	8	50	506	13.97	11230	4.32
SN75454BPE4	P	PDIP	8	50	506	13.97	11230	4.32
SNJ55451BFBK	FK	LCCC	20	1	506.98	12.06	2030	NA
SNJ55452BFBK	FK	LCCC	20	1	506.98	12.06	2030	NA
SNJ55453BFBK	FK	LCCC	20	1	506.98	12.06	2030	NA



D0008A

PACKAGE OUTLINE

SOIC - 1.75 mm max height

SMALL OUTLINE INTEGRATED CIRCUIT



NOTES:

1. Linear dimensions are in inches [millimeters]. Dimensions in parenthesis are for reference only. Controlling dimensions are in inches. Dimensioning and tolerancing per ASME Y14.5M.
2. This drawing is subject to change without notice.
3. This dimension does not include mold flash, protrusions, or gate burrs. Mold flash, protrusions, or gate burrs shall not exceed $.006$ [0.15] per side.
4. This dimension does not include interlead flash.
5. Reference JEDEC registration MS-012, variation AA.

EXAMPLE BOARD LAYOUT

D0008A

SOIC - 1.75 mm max height

SMALL OUTLINE INTEGRATED CIRCUIT



LAND PATTERN EXAMPLE
EXPOSED METAL SHOWN
SCALE:8X



SOLDER MASK DETAILS

4214825/C 02/2019

NOTES: (continued)

- 6. Publication IPC-7351 may have alternate designs.
- 7. Solder mask tolerances between and around signal pads can vary based on board fabrication site.

EXAMPLE STENCIL DESIGN

D0008A

SOIC - 1.75 mm max height

SMALL OUTLINE INTEGRATED CIRCUIT



SOLDER PASTE EXAMPLE
BASED ON .005 INCH [0.125 MM] THICK STENCIL
SCALE:8X

4214825/C 02/2019

NOTES: (continued)

8. Laser cutting apertures with trapezoidal walls and rounded corners may offer better paste release. IPC-7525 may have alternate design recommendations.
9. Board assembly site may have different recommendations for stencil design.

MECHANICAL DATA

PS (R-PDSO-G8)

PLASTIC SMALL-OUTLINE PACKAGE

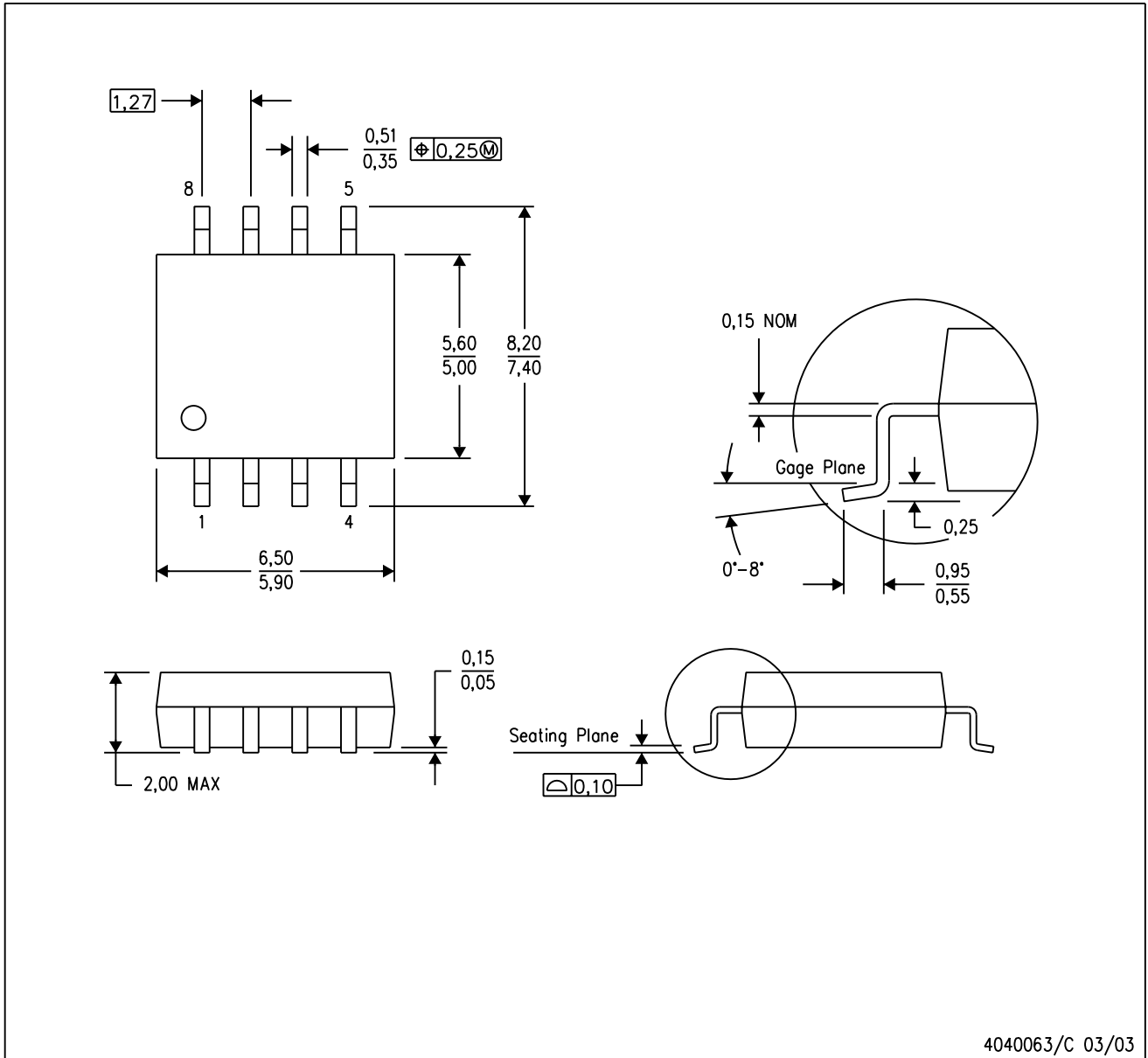

- NOTES:
- A. All linear dimensions are in millimeters.
 - B. This drawing is subject to change without notice.
 - C. Body dimensions do not include mold flash or protrusion, not to exceed 0,15.

PS (R-PDSO-G8)

PLASTIC SMALL OUTLINE

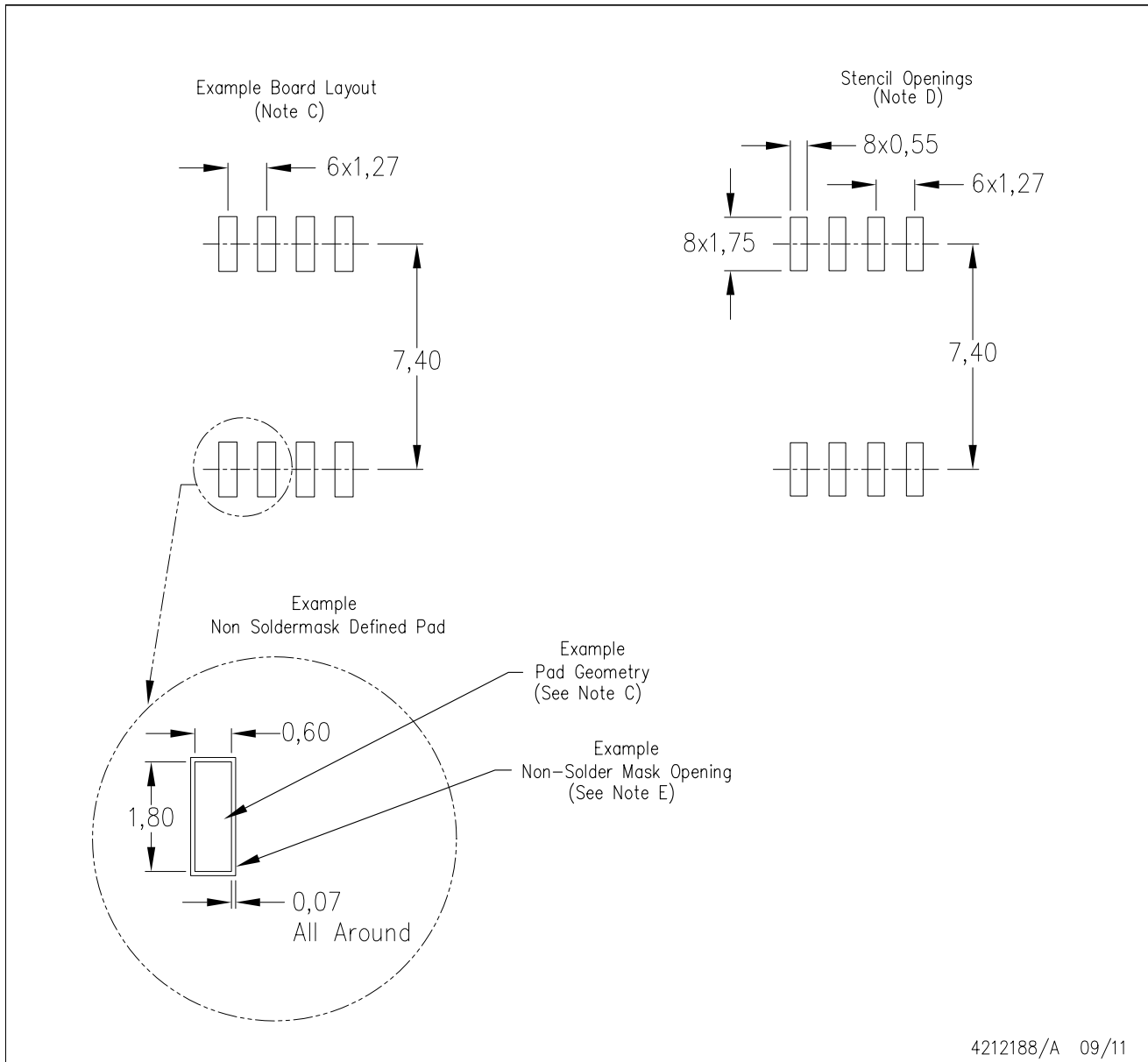

- NOTES:
- A. All linear dimensions are in millimeters.
 - B. This drawing is subject to change without notice.
 - C. Publication IPC-7351 is recommended for alternate designs.
 - D. Laser cutting apertures with trapezoidal walls and also rounding corners will offer better paste release. Customers should contact their board assembly site for stencil design recommendations. Refer to IPC-7525 for other stencil recommendations.
 - E. Customers should contact their board fabrication site for solder mask tolerances between and around signal pads.

JG (R-GDIP-T8)

CERAMIC DUAL-IN-LINE

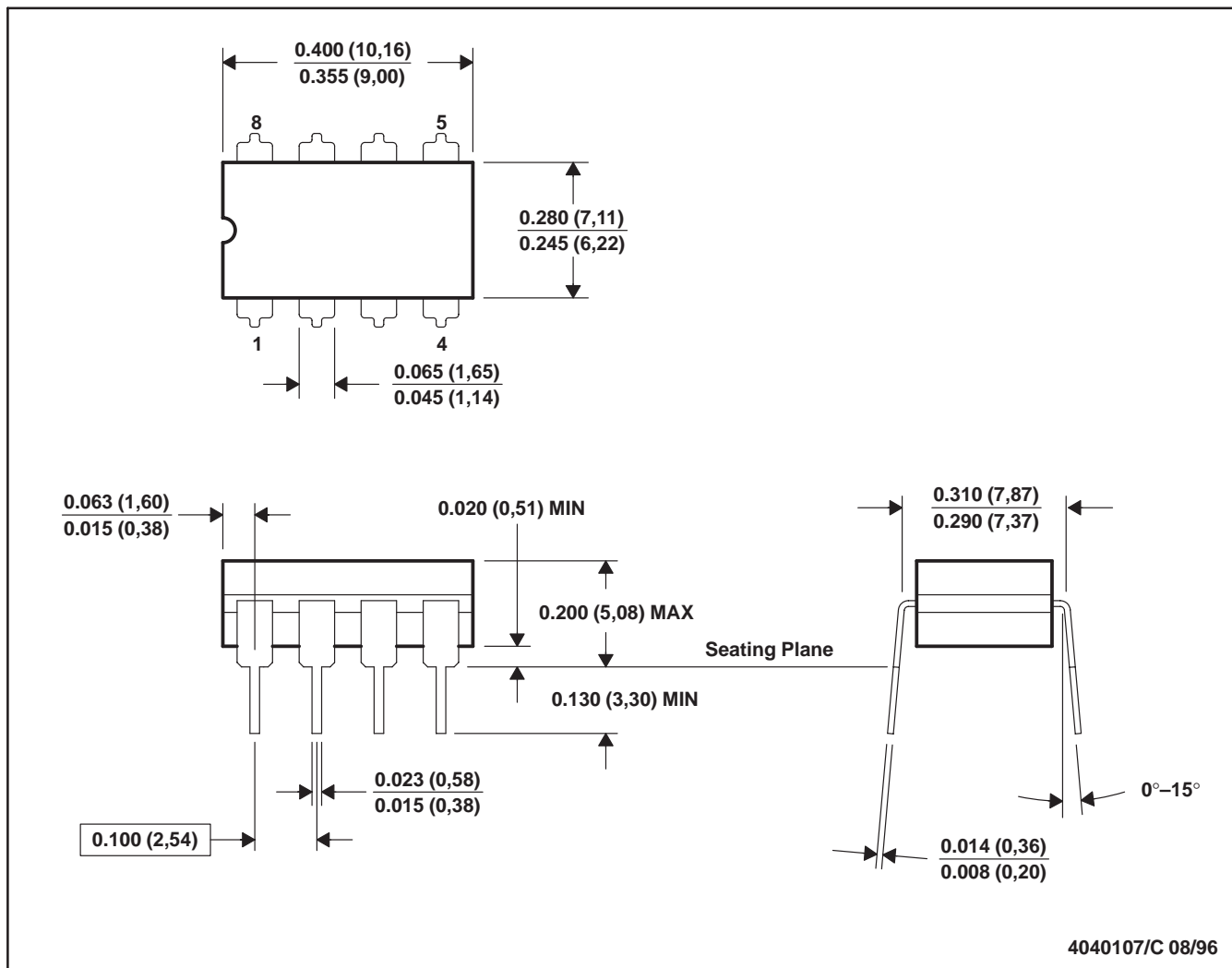

- NOTES: A. All linear dimensions are in inches (millimeters).
 B. This drawing is subject to change without notice.
 C. This package can be hermetically sealed with a ceramic lid using glass frit.
 D. Index point is provided on cap for terminal identification.
 E. Falls within MIL STD 1835 GDIP1-T8

P (R-PDIP-T8)

PLASTIC DUAL-IN-LINE PACKAGE



- NOTES:
- A. All linear dimensions are in inches (millimeters).
 - B. This drawing is subject to change without notice.
 - C. Falls within JEDEC MS-001 variation BA.

IMPORTANT NOTICE AND DISCLAIMER

TI PROVIDES TECHNICAL AND RELIABILITY DATA (INCLUDING DATA SHEETS), DESIGN RESOURCES (INCLUDING REFERENCE DESIGNS), APPLICATION OR OTHER DESIGN ADVICE, WEB TOOLS, SAFETY INFORMATION, AND OTHER RESOURCES "AS IS" AND WITH ALL FAULTS, AND DISCLAIMS ALL WARRANTIES, EXPRESS AND IMPLIED, INCLUDING WITHOUT LIMITATION ANY IMPLIED WARRANTIES OF MERCHANTABILITY, FITNESS FOR A PARTICULAR PURPOSE OR NON-INFRINGEMENT OF THIRD PARTY INTELLECTUAL PROPERTY RIGHTS.

These resources are intended for skilled developers designing with TI products. You are solely responsible for (1) selecting the appropriate TI products for your application, (2) designing, validating and testing your application, and (3) ensuring your application meets applicable standards, and any other safety, security, regulatory or other requirements.

These resources are subject to change without notice. TI grants you permission to use these resources only for development of an application that uses the TI products described in the resource. Other reproduction and display of these resources is prohibited. No license is granted to any other TI intellectual property right or to any third party intellectual property right. TI disclaims responsibility for, and you will fully indemnify TI and its representatives against, any claims, damages, costs, losses, and liabilities arising out of your use of these resources.

TI's products are provided subject to [TI's Terms of Sale](#) or other applicable terms available either on ti.com or provided in conjunction with such TI products. TI's provision of these resources does not expand or otherwise alter TI's applicable warranties or warranty disclaimers for TI products.

TI objects to and rejects any additional or different terms you may have proposed.

Mailing Address: Texas Instruments, Post Office Box 655303, Dallas, Texas 75265
Copyright © 2022, Texas Instruments Incorporated