

DRV3220-Q1 Three-Phase Automotive Gate Driver With Enhanced Protection, Diagnostics, and Monitoring

1 Features

- AEC-Q100 Qualified for Automotive Applications:
 - Device Temperature Grade 1: –40°C to +125°C Ambient Operating Temperature
- Three-Phase Bridge Driver for Motor Control
- Suitable for 12-V and 24-V Applications
- Integrated Boost Converter, Gate Drive to 4.75 V
- Drives 6 Separate N-Channel Power MOSFETs
- Strong 1-A Gate Drive for High-Current FETs
- Programmable Dead Time
- PWM Frequency up to 20 kHz
- Supports 100% Duty Cycle Operation
- Short-Circuit Protection
 - VDS-Monitoring (Adjustable Detection Level)
- Overvoltage and Undervoltage Protection
- Overtemperature Warning and Shut Down
- Sophisticated Failure Detection and Handling Through SPI
- System Supervision
 - Q&A Watchdog
 - I/O Supply Monitoring
 - ADREF Monitoring
- Programmable Internal Fault Diagnostics
- Sleep Mode Function
- Thermally-Enhanced 48-Pin HTQFP PowerPAD™ IC Package (7-mm x 7-mm Body)

2 Applications

- Automotive Motor-Control Applications
 - Electrical Power Steering (EPS, EHPS)
 - Electrical Brake and Brake Assist
 - Transmission
 - Pumps
- Industrial Motor-Control Applications

3 Description

The DRV3220-Q1 bridge driver is dedicated to automotive three-phase brushless DC motor control applications. The device provides six dedicated drivers for standard-level N-channel MOSFET transistors. A boost converter with an integrated FET provides the overdrive voltage, allowing full control on the power stages even for low battery voltage down to 4.75 V. The strong driver strength is suitable for high-current applications and programmable to limit peak output current.

The device incorporates robust FET protection and system monitoring functions like a Q&A watchdog and voltage monitors for I/O supplies and ADC reference voltages. Integrated internal diagnostic functions can be accessed and programmed through an SPI interface.

Device Information⁽¹⁾

PART NUMBER	PACKAGE	BODY SIZE (NOM)
DRV3220-Q1	HTQFP (48)	7.00 mm x 7.00 mm

(1) For all available packages, see the orderable addendum at the end of the data sheet.

Typical Application Diagram

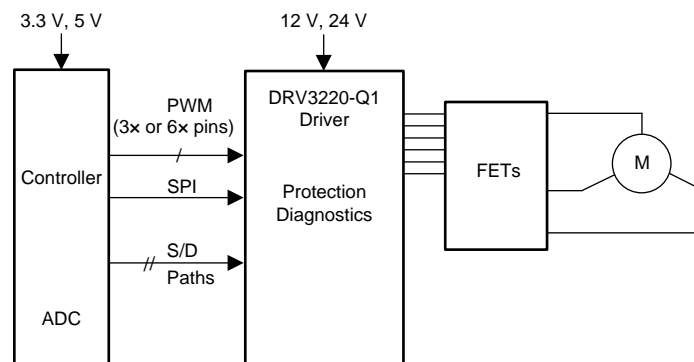

Copyright © 2017, Texas Instruments Incorporated



Table of Contents

1 Features	1	7.4 Register Maps	17
2 Applications	1	8 Application and Implementation	19
3 Description	1	8.1 Application Information.....	19
4 Revision History	2	8.2 Typical Application	20
5 Pin Configuration and Functions	3	8.3 System Example	20
6 Specifications	5	9 Power Supply Recommendations	22
6.1 Absolute Maximum Ratings	5	10 Layout	22
6.2 ESD Ratings.....	6	10.1 Layout Guidelines	22
6.3 Recommended Operating Conditions.....	6	10.2 Layout Example	22
6.4 Thermal Information	7	11 Device and Documentation Support	23
6.5 Electrical Characteristics.....	7	11.1 Documentation Support	23
6.6 Serial Peripheral Interface Timing Requirements ...	11	11.2 Receiving Notification of Documentation Updates	23
6.7 Typical Characteristics	12	11.3 Community Resources.....	23
7 Detailed Description	13	11.4 Trademarks	23
7.1 Overview	13	11.5 Electrostatic Discharge Caution.....	23
7.2 Functional Block Diagram	13	11.6 Glossary	23
7.3 Programming.....	14	12 Mechanical, Packaging, and Orderable Information	23

4 Revision History

NOTE: Page numbers for previous revisions may differ from page numbers in the current version.

DATE	REVISION	NOTES
February 2017	*	Initial release.

5 Pin Configuration and Functions

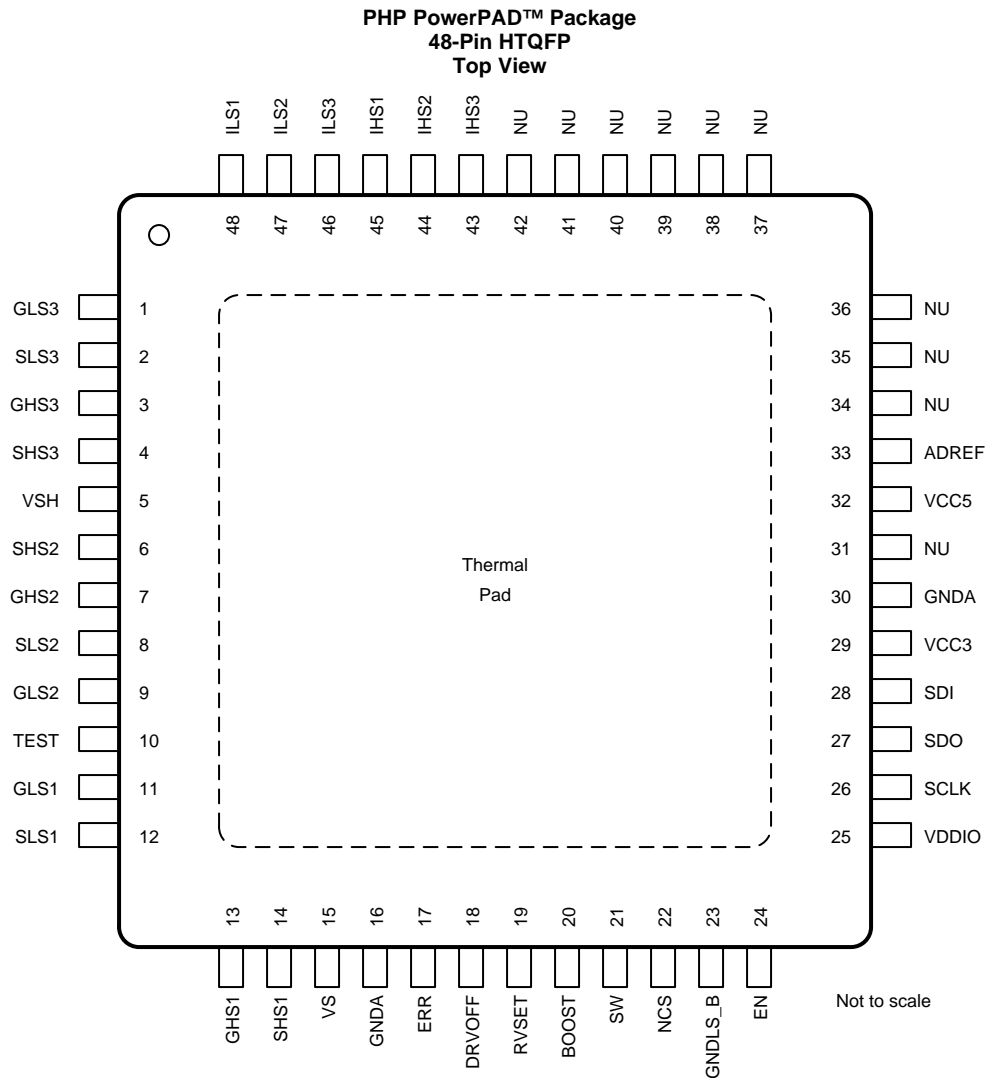

Pin Functions

PIN		TYPE ⁽¹⁾	DESCRIPTION
NO.	NAME		
1	GLS3	PWR	Gate low-side 3, connected to gate of external power MOSFET.
2	SLS3	PWR	Source low-side 3, connected to external power MOSFET for gate discharge and VDS monitoring.
3	GHS3	PWR	Gate high-side 3, connected to gate of external power MOSFET.
4	SHS3	PWR	Source high-side 3, connected to external power MOSFET for gate discharge and VDS monitoring.
5	VSH	HVI_A	Sense high-side, sensing VS connection of the external power MOSFETs for VDS monitoring.
6	SHS2	PWR	Source high-side 2, connected to external power MOSFET gate discharge and VDS monitoring.
7	GHS2	PWR	Gate high-side 2, connected to gate of external power MOSFET.
8	SLS2	PWR	Source low-side 2, connected to external power MOSFET for gate discharge and VDS monitoring.
9	GLS2	PWR	Gate low-side 2, connected to gate of external power MOSFET.
10	TEST	HVI_A	Test mode input, during normal application connected to ground.

(1) Description of pin type: GND = Ground; HVI_A = High-voltage input analog; HVI_D = High-voltage input digital; LVI_A = Low-voltage input analog; LVO_A = Low-voltage output analog; LVO_D = Low-voltage output digital; NC = No connect; PWR = Power output; Supply = Supply input

Pin Functions (continued)

PIN		TYPE ⁽¹⁾	DESCRIPTION
NO.	NAME		
11	GLS1	PWR	Gate low-side 1, connected to gate of external power MOSFET.
12	SLS1	PWR	Source low-side 1, connected to external power MOSFET for gate discharge and VDS monitoring.
13	GHS1	PWR	Gate high-side 1, connected to gate of external power MOS transistor.
14	SHS1	PWR	Source high-side 1, connected to external power MOS transistor for gate discharge and VDS.
15	VS	Supply	Power-supply voltage (externally protected against reverse battery connection).
16	GND_A	GND	Analog ground.
17	ERR	LVO_D	Error (low active), Error pin to indicate detected error.
18	DRVOFF	HVI_D	Driver OFF (high active), secondary bridge driver disable.
19	RVSET	HVI_A	VDDIO / ADREF OV/UV configuration resistor.
20	BOOST	Supply	Boost output voltage, used as supply for the gate drivers.
21	SW	PWR	Boost converter switching node connected to external coil and external diode.
22	NCS	HVI_D	SPI chip select.
23	GNDLS_B	GND	Boost GND to set current limit. Boost switching current goes through this pin through external resistor to ground.
24	EN	HVI_D	Enable (high active) of the device.
25	VDDIO	Supply	I/O supply voltage, defines the interface voltage of digital I/O, for example, SPI.
26	SCLK	HVI_D	SPI clock.
27	SDO	LVO_D	SPI data output.
28	SDI	HVI_D	SPI data input.
29	VCC3	LVO_A	VCC3 regulator, for internal use only. TI recommends an external decoupling capacitor of 0.1 μ F. External load < 100 μ A.
30	GND_A	GND	Analog ground.
31	NU	—	Not used. Leave this pin open.
32	VCC5	LVO_A	VCC5 regulator, for internal use only. Recommended external decoupling capacitor 1 μ F. External load < 100 μ A.
33	ADREF	LVI_A	ADC reference of MCU. Connect to VDDIO
34	NU	—	Not used. Leave this pin open.
35	NU	—	Not used. Leave this pin open.
36	NU	—	Not used. Leave this pin open.
37	NU	—	Not used. Connect this pin to ground.
38	NU	—	Not used. Connect this pin to ground.
39	NU	—	Not used. Connect this pin to ground.
40	NU	—	Not used. Connect this pin to ground.
41	NU	—	Not used. Connect this pin to ground.
42	NU	—	Not used. Connect this pin to ground.
43	IHS3	HVI_D	High-side input 3, digital input to drive the HS3.
44	IHS2	HVI_D	Input HS 2, digital input to drive the HS2.
45	IHS1	HVI_D	Input HS 1, digital input to drive the HS1.
46	ILS3	HVI_D	Low-side input 3, digital input to drive the LS3.
47	ILS2	HVI_D	Input LS 2, digital input to drive the LS2.
48	ILS1	HVI_D	Input LS 1, digital input to drive the LS1.

6 Specifications

6.1 Absolute Maximum Ratings

over operating free-air temperature range (unless otherwise noted)⁽¹⁾⁽²⁾

POS			MIN	MAX	UNIT
2.1	DC voltage	VS, VSH	-0.3	60	V
2.1a		VS	Negative voltages with minimum serial resistor 5 Ω, T _A = 25°C		V
2.1c			Negative voltages with minimum serial resistor 5 Ω, T _A = 105°C		V
2.1b		VSH	Negative voltages with minimum serial resistor 10 Ω, T _A = 25°C		V
2.1d			Negative voltages with minimum serial resistor 10 Ω, T _A = 105°C		V
2.2A		Gate high-side voltage	GHSx	-9	70
2.2B	Source high-side voltage	SHSx	-9	70	V
2.3	Gate-source high-side voltage difference	GHSx-SHSx	Externally driven, internal limited, see position 5.4 in Electrical Characteristics		V
2.4	Gate low-side voltage	GLSx	-9	20	V
2.5	Source low-side voltage	SLSx	-9	7	V
2.6	Gate-source low-side voltage difference	GLSx-SLSx	Externally driven, internal limited, see position 5.5 in Electrical Characteristics		V
2.7	Boost converter	BOOST, SW	-0.3	70	V
2.9	Analog input voltage	VDDIO	-0.3	60	V
2.9a		ADREF	-0.3	60	V
2.11		RVSET	-0.3	60	V
2.10	Digital input voltage	ILSx, IHSx, EN, DRVOFF, SCLK, NCS, SDI	-0.3	60	V
2.13	Difference between GND _A and GND _{L_S_B}	GND _A , GND _{L_S_B}	-0.3	0.3	V
2.20	Maximum slew rate of SHSx pins, SR _{SHS}		-250	250	V/μs
2.21	Analog and digital output voltages	ERR, SDO, RO	-0.3	6	V
2.22	Unused pins (connect to GND)	TEST	-0.3	0.3	V
2.24	Internal supply voltage	VCC5	-0.3	6	V
2.25		VCC3	-0.3	3.6	V
2.21 A	Forced input and output current	ERR, SDO, RO	-10	10	mA
2.24 A	Short-to-ground current, I _{VCC5} ⁽³⁾	Internal current limit		80	mA
2.26	Short-to-ground current, I _{VCC3}	Limited by VCC5		80	mA
2.27	Driver FET total gate charge (per FET), Q _{gmax}	VS = 12 V, f _{PWM} = 20 kHz, 6 FETs ON/OFF per PWM cycle		200 ⁽⁴⁾	nC
2.28		VS = 24 V, f _{PWM} = 20 kHz, 6 FETs ON/OFF per PWM cycle		100 ⁽⁴⁾	nC

- (1) Stresses beyond those listed under *Absolute Maximum Ratings* may cause permanent damage to the device. These are stress ratings only, which do not imply functional operation of the device at these or any other conditions beyond those indicated under *Recommended Operating Conditions*. Exposure to absolute-maximum-rated conditions for extended periods may affect device reliability.
- (2) All voltages are with respect to network ground terminal, unless specified otherwise.
- (3) I_{VCC5} is not specifying VCC5 output current capability for external load. The allowed external load on VCC5 is specified at position 3.18 in [Recommended Operating Conditions](#).
- (4) The maximum value also depends on PCB thermal design, modulation scheme, and motor operation time.

Absolute Maximum Ratings (continued)

 over operating free-air temperature range (unless otherwise noted)⁽¹⁾⁽²⁾

POS		MIN	MAX	UNIT
2.14	Operating virtual junction temperature, T_J	-40	150	°C
2.15	Storage temperature, T_{stg}	-55	165	°C

6.2 ESD Ratings

POS		VALUE	UNIT
2.17	$V_{(ESD)}$ Electrostatic discharge	Human-body model (HBM), per AEC Q100-002 ⁽¹⁾	All pins ±2000
2.18		Charged-device model (CDM), per AEC Q100-011	Pins 4, 6, and 14 ±4000
2.19			All pins ±500
		Corner pins (1, 12, 13, 24, 25, 36, 37, and 48) ±750	

(1) AEC Q100-002 indicates that HBM stressing shall be in accordance with the ANSI/ESDA/JEDEC JS-001 specification.

6.3 Recommended Operating Conditions

POS		MIN	NOM	MAX	UNIT	
3.1	V_{VS} Supply voltage, normal voltage operation	Full device functionality. Operation at $V_S = 4.75$ V only when coming from higher V_S . Minimum V_S for startup = 4.85 V		4.75	40	V
3.2	V_{VSLO} Supply voltage, logic operation	Logic functional (during battery cranking after coming from full device functionality)		4	40	V
3.3	V_{VDDIO} Supply voltage for digital I/Os			2.97	5.5	V
3.14	V_{CC3} Internal supply voltage	$V_S > 4$ V, external load current < 100 μ A, decoupling capacitor typical 0.1 μ F		3 ⁽¹⁾	3.3	V
3.17	V_{CC5} Internal supply voltage	$V_S > 6$ V, external load current < 100 μ A, decoupling capacitor typical 1 μ F		5.15	5.45	V
3.6A	I_{VSn} VS quiescent current normal operation (boost converter enabled, drivers not switching)	Boost converter enabled, see and for SHSx/SLSx connections. EN_GDBIAS = 1			22	mA
3.61A		Boost converter enabled, see and for SHSx/SLSx connections. EN_GDBIAS = 0			22.3	mA
3.6B	I_{BOOSTn} BOOST pin quiescent current normal operation (drivers not switching)	4.75 V $< V_S < 20$ V, $T_A = 25^\circ$ C to 125° C			9	mA
3.62B		4.75 V $< V_S < 20$ V, $T_A = -40^\circ$ C			10	
3.6C		$20 < V_S < 40$ V, $T_A = 25^\circ$ C to 125° C			9.5	
3.6C1		$20 < V_S < 40$ V, $T_A = -40^\circ$ C			10.5	
3.61B	I_{VSn} VS quiescent additional current normal operation because of RVSET thermal voltage output enabled (boost converter enabled, drivers not switching)	THERMAL_RVSET_EN = 1			0.6	mA
3.6D	$I_{BOOST,sw}$ BOOST pin additional load current because of switching gate drivers	Excluding FET gate charge current. 20-kHz all gate drivers switching at the same time. EN_GDBIAS = 1			4	mA
3.61D		Excluding FET gate charge current. 20-kHz all gate drivers switching at the same time. EN_GDBIAS = 0			5.4	
3.75	I_{VSq_1} VS quiescent current shutdown (sleep mode) 1	$V_S = 14$ V, no operation, $T_J < 25^\circ$ C, EN = Low, total leakage current on all supply connected pins			20	μ A
3.75a	I_{VSq_2} VS quiescent current shutdown (sleep mode) 2	$V_S = 14$ V, no operation, $T_J < 85^\circ$ C, EN = Low, total leakage current on all supply connected pins			30	μ A
3.15	I_{VCC3} VCC3 output current	Intended for MCU ADC input		0	100	μ A
3.18	I_{VCC5} VCC5 output current	Intended for MCU ADC input		0	100	μ A
3.16	C_{VCC3} VCC3 decoupling capacitance	0.075	0.1	0.2		μ F
3.19	C_{VCC5} VCC5 decoupling capacitance	0.5	1	1.5		μ F
3.4	D Duty cycle of bridge drivers	0%			100%	
3.5	f_{PWM} PWM switching frequency	0			22 ⁽¹⁾	kHz

(1) Maximum PWM allowed also depends on maximum operating temperature, FET gate charge current, VS supply voltage, modulation scheme, and PCB thermal design.

Recommended Operating Conditions (continued)

POS			MIN	NOM	MAX	UNIT
3.8	T _J	Junction temperature	-40		150	°C
3.9	T _A	Operating ambient free-air temperature	-40	With proper thermal connection	125	°C

6.4 Thermal Information

THERMAL METRIC ⁽¹⁾		DRV3220-Q1	UNIT
		PHP (HTQFP)	
		48 PINS	
R _{θJA}	Junction-to-ambient thermal resistance	25.7	°C/W
R _{θJC(top)}	Junction-to-case (top) thermal resistance	10.3	°C/W
R _{θJB}	Junction-to-board thermal resistance	6	°C/W
Ψ _{JT}	Junction-to-top characterization parameter	0.2	°C/W
Ψ _{JB}	Junction-to-board characterization parameter	5.9	°C/W
R _{θJC(bot)}	Junction-to-case (bottom) thermal resistance	0.3	°C/W

(1) For more information about traditional and new thermal metrics, see the [Semiconductor and IC Package Thermal Metrics](#) application report.

6.5 Electrical Characteristics

over operating temperature T_J = -40°C to 150°C and recommended operating conditions, V_S = 4.75 V to 40 V⁽¹⁾, f_{PWM} < 20 kHz (unless otherwise noted)

POS	PARAMETER	TEST CONDITIONS	MIN	TYP	MAX	UNIT		
4.4	ADREF / VDDIO							
4.4.3	I _{ADREF}	ADREF bias current	ADREF = 3.3 V, pin to ground		300	μA		
4.4.4	V _{ovadref}	Overvoltage threshold, ADREF	ADREF: 3.3-V setting by RVSET resistor		3.696	3.795	3.894	V
4.4.4a			ADREF: 5-V setting by RVSET resistor		5.6	5.75	5.9	V
4.4.5	V _{uvadref}	Undervoltage threshold, ADREF	ADREF: 3.3-V setting by RVSET resistor		2.706	2.805	2.904	V
4.4.5a			ADREF: 5-V setting by RVSET resistor		4.1	4.25	4.4	V
4.4.7	V _{ovvddio}	Overvoltage threshold, VDDIO	VDDIO: 3.3-V setting by RVSET resistor		3.696	3.795	3.894	V
4.4.7a			VDDIO: 5-V setting by RVSET resistor		5.6	5.75	5.9	V
4.4.8	V _{uvvddio}	Undervoltage threshold, VDDIO	VDDIO: 3.3-V setting by RVSET resistor		2.706	2.805	2.904	V
4.4.8a			VDDIO: 5-V setting by RVSET resistor		4.1	4.25	4.4	V
4.4.10	R _{RVSET33}	RVSET resistance	VDDIO = 3.3 V; ADREF = 3.3-V mode; STAT6 bit[3:0] = 4'b0001		135	150	165	kΩ
4.4.11	R _{RVSET53}		VDDIO = 5 V; ADREF = 3.3-V mode; STAT6 bit[3:0] = 4'b0100		46	51	56.5	kΩ
4.4.12	R _{RVSET35}		VDDIO = 3.3 V; ADREF = 5-V mode; STAT6 bit[3:0] = 4'b1000		13.5	15	16.5	kΩ
4.4.13	R _{RVSET55}		VDDIO = 5 V; ADREF = 5-V mode; STAT6 bit[3:0] = 4'b0010		4.6	5.1	5.65	kΩ
4.4.30	R _{RVSETopen}	RVSET resistor error detection	Open		650		kΩ	
4.4.31	R _{RVSETshort}		Short		1.5			
4.4.32	V _{RVSETn40}	RVSET output voltage	-40°C T _J , THERMAL_RVSET_EN = 1		1.67	1.745	1.82	V
4.4.33	V _{RVSET25}		25°C T _J , THERMAL_RVSET_EN = 1		1.445	1.535	1.625	
4.4.34	V _{RVSET125}		125°C T _J , THERMAL_RVSET_EN = 1		1.085	1.195	1.305	
VCC3 / VCC5 REGULATORS								
4.4.14	VCC3	VCC3 regulator output voltage	V _S > 4 V		3	3.15	3.3	V
4.4.15	VCC3 _{UV}	VCC3 regulator undervoltage threshold	V _S > 4 V		2.7	2.85	3	V
4.4.16	VCC3 _{OV}	VCC3 regulator overvoltage threshold ⁽²⁾	V _S > 4 V		3.3	3.45	3.6	V

(1) Product life time depends on V_S voltage, PCB thermal design, modulation scheme, and motor operation time. The product is designed for 12-V and 24-V battery system.

(2) ADREF / VDDIO overvoltage and undervoltage is set by RVSET.

Electrical Characteristics (continued)

over operating temperature $T_J = -40^\circ\text{C}$ to 150°C and recommended operating conditions, $V_S = 4.75\text{ V}$ to $40\text{ V}^{(1)}$, $f_{\text{PWM}} < 20\text{ kHz}$ (unless otherwise noted)

POS	PARAMETER	TEST CONDITIONS	MIN	TYP	MAX	UNIT		
4.4.17	V_{CC5_1} VCC5 regulator output voltage 1	$V_S > 6\text{ V}$	5.15	5.3	5.45	V		
4.4.18	V_{CC5_2} VCC5 regulator output voltage 2	$6\text{ V} > V_S > 4.75\text{ V}$	4.6		5.45	V		
4.4.19	$V_{\text{CC5}_{\text{UV}}}$ VCC5 regulator undervoltage threshold	$V_S > 4.75\text{ V}$	4.3		4.6	V		
4.4.20	$V_{\text{CC5}_{\text{OV}}}$ VCC5 regulator overvoltage threshold	$V_S > 4.75\text{ V}$	5.45	5.6	5.75	V		
5.	GATE DRIVER							
5.1	$V_{\text{GS,low}}$ Gate-source voltage low, high-side/low-side driver	Active pulldown, $I_{\text{load}} = -2\text{ mA}$	0		0.2	V		
5.2	R_{GSp} Passive gate-source resistance	$V_{\text{gs}} \leq 200\text{ mV}$	110	220	330	k Ω		
5.3	R_{GSsa} Semi-active gate-source resistance	In sleep mode, $V_{\text{GS}} > 2\text{ V}$		2	4	k Ω		
5.3b	I_{GSL01}	Low-side driver pullup/pulldown current	Gate driven low by gate driver, CURR1, 3 = 01, SPI configurable		TYP \times 0.65	0.65	TYP \times 1.35	A
5.3c	I_{GSL00}		Gate driven low by gate driver ⁽²⁾ , CURR1, 3 = 00, SPI configurable		TYP \times 0.1	0.15	TYP \times 1.9	A
5.3d	I_{GSL10}		Gate driven low by gate driver, CURR1, 3 = 11, SPI configurable		TYP \times 0.65	1.1	TYP \times 1.35	A
5.3f	I_{GSH01}	High-side driver pullup/pulldown current	Gate driven low by gate driver, CURR0, 2 = 01, SPI configurable		TYP \times 0.65	0.65	TYP \times 1.35	A
5.3g	I_{GSH00}		Gate driven low by gate driver ⁽²⁾ , CURR0, 2 = 00, SPI configurable		TYP \times 0.1	0.15	TYP \times 1.9	A
5.3h	I_{GSH11}		Gate driven low by gate driver, CURR0, 2 = 11, SPI configurable		TYP \times 0.65	1.1	TYP \times 1.35	A
5.3i	I_{GSHsd} High-side/low-side driver shutdown current		2	30	70	mA		
5.4	$V_{\text{GS,HS,high}}$ High-side output voltage	$I_{\text{load}} = -2\text{ mA}$; $4.75\text{ V} < V_S < 40\text{ V}$	9		13.4	V		
5.5	$V_{\text{GS,LS,high}}$ Low-side output voltage	$I_{\text{load}} = -2\text{ mA}$	9		13.4	V		
5.27	t_{Don} Propagation on delay time	After ILx/IHx rising edge, $C_{\text{load}} = 10\text{ nF}$, CURR1, 3 = 10, $V_{\text{GS}} = 1\text{ V}$	100	200	350	ns		
5.31	A_{dt} Accuracy of dead time	If not disabled in CFG1	-15%		15%			
5.32	I_{HSxlk_1}	Source leak current, total leakage current of source pins	EN = L, SHSx = 1.5 V, $T_J < 125^\circ\text{C}$		-5		5	μA
5.32a	I_{HSxlk_2}		EN = L, SHSx = 1.5 V, $125^\circ\text{C} < T_J < 150^\circ\text{C}$		-40		40	μA
5.29	t_{Doff} Propagation off delay time ⁽³⁾	ILx/IHx falling edge to $V_{\text{GS,LS,high}}(V_{\text{GS,HS,high}}) - 1\text{ V}$ $C_{\text{iss}} = 10\text{ nF}$, CURR1,3 = 10,	100	200	350	ns		
5.30	t_{Doffdiff} Propagation off delay time difference ⁽³⁾	LSx to LSy and HSx to HSy $C_{\text{load}} = 10\text{ nF}$, CURR1,3 = 10, $V_{\text{GS,LS,high}}(V_{\text{GS,HS,high}}) - 1\text{ V}$			50	ns		
5.30a	$t_{\text{Don_Doff_diff}}$ Difference between propagation on delay time and propagation off delay time ⁽³⁾	For each gate driver in each channel: $C_{\text{load}} = 10\text{ nF}$, CURR1, 3 = 10, $V_{\text{GS}} = 1\text{ V}$ (rising), $V_{\text{GS,LS,high}}(V_{\text{GS,HS,high}}) - 1\text{ V}$ (falling)			150	ns		
5.30c	t_{ENoff} Propagation off (EN) deglitch time ⁽³⁾	After falling edge on EN	2.5	6	12	μs		
5.30d	t_{SD} Time until gate drivers initiate shutdown ⁽³⁾	After falling edge on EN		12	24	μs		
5.30e	t_{SDDRV} Time until gate drivers initiate shutdown ⁽³⁾	After rising edge on DRVOFF			10	μs		

(3) Ensured by characterization.

Electrical Characteristics (continued)

over operating temperature $T_J = -40^\circ\text{C}$ to 150°C and recommended operating conditions, $V_S = 4.75\text{ V}$ to $40\text{ V}^{(1)}$, $f_{\text{PWM}} < 20\text{ kHz}$ (unless otherwise noted)

POS	PARAMETER		TEST CONDITIONS	MIN	TYP	MAX	UNIT
6.	BOOST CONVERTER						
6.1	V_{BOOST}	Boost output voltage excluding switching ripple and response delay.	BOOST – V_S voltage	14	15	16.5	V
6.1b	V_{BOOSTOV}	Boost output voltage overvoltage with respect GND		64	67.5	70	V
6.2	I_{BOOST}	Output current capability	External load current including external MOSFET gate charge current BOOST – $V_S > V_{\text{BOOSTUV}}$	40			mA
6.3	f_{BOOST}	Switching frequency	BOOST – $V_S > V_{\text{BOOSTUV}}$; ensured by characterization ⁽⁴⁾	1.8	2.5	3	MHz
6.31			BOOST – $V_S > V_{\text{BOOSTUV}}$; $V_S < 6\text{ V}$; ensured by characterization ⁽⁴⁾	1.1		3	
6.4	V_{BOOSTUV}	Undervoltage shutdown level	BOOST – V_S voltage	7		8	V
6.4a	V_{BOOSTUV2}	Undervoltage condition that device may enter RESET state	BOOST – GND voltage			10	V
6.5	t_{BCSD}	Filter time for undervoltage detection		5		6	μs
6.7	$V_{\text{GNDLS_B,off}}$	Voltage at GNDLS_B pin at which boost FET switches off because of current limit		110	150	200	mV
6.7a	$t_{\text{SW,off}}$	Delay of the GNDLS_B current limit comparator	Specified by design			100	ns
6.8	$I_{\text{SW,fail}}$	Internal second-level current limit	GNDLS_B = 0 V	840		1600	mA
6.9	$R_{\text{dson_BSTfet}}$	R_{dson} resistance boost FET	$V_S \geq 6$; $I_{\text{SW}} = V_{\text{GNDLS_B,off}} / 0.33\ \Omega$	0.25		1.5	Ω
6.9a			$V_S < 6$; $I_{\text{SW}} = V_{\text{GNDLS_B,off}} / 0.33\ \Omega$			2	Ω
7.	DIGITAL INPUTS						
7.1	INL	Input low threshold	All digital inputs NCS, DRVOFF, ILSx, IHSx, SDI			$V_{\text{DDIO}} \times 0.3$	V
7.1a	ENH	EN input high threshold	$V_S > 4\text{ V}$	2.7			V
7.1b	ENL	EN input low threshold	$V_S > 4\text{ V}$			0.7	V
7.2	INH	Input high threshold	All digital inputs NCS, DRVOFF, ILSx, IHSx, SDI	$V_{\text{DDIO}} \times 0.7$			V
7.3	Inhys	Input hysteresis	All digital inputs EN, NCS, DRVOFF, ILSx, IHSx, SDI, $V_{\text{DDIO}} = 5\text{ V}$	0.3	0.4		V
7.3a			All digital inputs EN, NCS, DRVOFF, ILSx, IHSx, SDI, $V_{\text{DDIO}} = 3.3\text{ V}$	0.2	0.3		V
7.4	$R_{\text{pd,EN}}$	Input pulldown resistor at EN pin	EN	140	200	360	k Ω
7.4a	$t_{\text{deg,ENon}}$	Power-up time after EN pin high from sleep mode to active mode	ERR = L \rightarrow H			5	ms
7.5	R_{pullup}	Input pullup resistance	NCS, DRVOFF	200	280	400	k Ω
7.6	R_{pulldown}	Input pulldown resistance	ILSx, IHSx, SDI, SCLK Input voltage = 0.1 V	100	140	200	k Ω
7.6a	R_{pulldown}	Input pulldown current	ILSx, IHSx, SDI, SCLK Input voltage = V_{DDIO}	4		50	μA
8.	DIGITAL OUTPUTS						
8.1	OH1	Output high voltage 1	All digital outputs: SDO, $I = \pm 2\text{ mA}$; V_{DDIO} in functional range ⁽⁵⁾	$V_{\text{DDIO}} \times 0.9$			V
8.2	OL1	Output low voltage 1	All digital outputs: SDO, $I = \pm 2\text{ mA}$; V_{DDIO} in functional range			$V_{\text{DDIO}} \times 0.1$	V
8.1	OH2	Output high voltage 2	ERR $I = -0.2\text{ mA}$; V_{DDIO} in functional range	$V_{\text{DDIO}} \times 0.9$			V
8.2	OL2	Output low voltage 2	ERR $I = +0.2\text{ mA}$; V_{DDIO} in functional range			$V_{\text{DDIO}} \times 0.1$	V
9.	VDS, VGS, MONITORING						
9.1	V_{SCTH}	VDS short-circuit threshold range	If not disabled in CFG1	0.1		2	V

(4) During startup when $\text{BOOST} - V_S < V_{\text{BOOSTUV}}$, f_{BOOST} is typically 1.25 MHz.

(5) All digital outputs have a push-pull output stage between V_{DDIO} and ground.

Electrical Characteristics (continued)

over operating temperature $T_J = -40^{\circ}\text{C}$ to 150°C and recommended operating conditions, $V_S = 4.75\text{ V}$ to $40\text{ V}^{(1)}$, $f_{\text{PWM}} < 20\text{ kHz}$ (unless otherwise noted)

POS	PARAMETER	TEST CONDITIONS	MIN	TYP	MAX	UNIT		
9.2	A_{Vds}	Accuracy of VDS monitoring	0.1-V to 0.5-V threshold setting		-50	50	mV	
			0.6-V to 2-V threshold setting		-10%	10%		
9.3	t_{VDS}	Detection filter time	Only rising edge of VDS comparators are filtered		5	μs		
9.4	$V_{\text{gserr+}_1}$	VGS error detection 1	STAT7, IHSx (ILSx) = H		7	8.5	V	
9.5	$V_{\text{gserr-}}$	VGS error detection	STAT7, IHSx (ILSx) = L			2	V	
9.6	t_{VGS}	Detection filter time	CFG6[5:4]		1.0		μs	
9.6a	t_{VGSm}	Detection mask time	CFG6[2:0]		2.5		μs	
10.	THERMAL SHUTDOWN							
10.1	T_{msd0}	Thermal recovery	Specified by characterization		130	153	178	$^{\circ}\text{C}$
10.2	T_{msd1}	Thermal warning	Specified by characterization		140	165	190	$^{\circ}\text{C}$
10.3	T_{msd2}	Thermal global reset	Specified by characterization		170	195	220	$^{\circ}\text{C}$
10.4	T_{hmsd}	Thermal shutdownx2 hysteresis	Specified by characterization			40		$^{\circ}\text{C}$
10.5	t_{rSD1}	Thermal warning filter time	Specified by characterization		40	45	50	μs
10.6	t_{rSD2}	Thermal shutdownx2 filter time	Specified by characterization		2.5	6	12	μs
12.	VS MONITORING							
12.1	$V_{\text{VS,OVoff0}}$	Overvoltage shutdown level range ⁽⁶⁾	Programmable CFG5 mode1, 12-V/24-V mode		29		38	V
12.1a	$V_{\text{VS,OVoff1}}$	Overvoltage shutdown level ⁽⁶⁾	29-V threshold setting		27.5	29	30.5	V
12.1b	$V_{\text{VS,OVon1}}$	Recovery level form overvoltage shutdown ⁽⁶⁾	29-V threshold setting		26.5	28	29.5	V
12.1c	$V_{\text{VS,OVoff2}}$	Overvoltage shutdown level ⁽⁶⁾	33-V threshold setting		32	33.5	35	V
12.1d	$V_{\text{VS,OVon2}}$	Recovery level form overvoltage shutdown ⁽⁶⁾	33-V threshold setting		31	32.5	34	V
12.1e	$V_{\text{VS,OVoff3}}$	Overvoltage shutdown level ⁽⁶⁾	38-V threshold setting		36.5	38	39.5	V
12.1f	$V_{\text{VS,OVon3}}$	Recovery level form overvoltage shutdown ⁽⁶⁾	38-V threshold setting		35.5	37	38.5	V
12.2	$V_{\text{VS,UVoff}}$	Undervoltage shutdown level ⁽⁶⁾	VS is falling from higher voltage than 4.75 V		4.5		4.75	V
12.2a	$V_{\text{VS,UVon}}$	Recovery level form undervoltage shutdown ⁽⁶⁾	Minimum VS for device startup		4.6		4.85	V
12.3	$t_{\text{VS,SHD}}$	Filter time for overvoltage/undervoltage shutdown			5		6	μs

(6) Shutdown signifies *predriver shutdown*, not VCC3/VCC5 regulator shutdown.

6.6 Serial Peripheral Interface Timing Requirements

POS 13		MIN	NOM	MAX	UNIT
13.1	f_{SPI}			4 ⁽¹⁾	MHz
13.2	t_{SPI}	250			ns
13.3	t_{high}	90			ns
13.4	t_{low}	90			ns
13.5	t_{sucs}	$t_{SPI} / 2$			ns
13.6	t_{d1}			60	ns
13.7	t_{susi}	30			ns
13.8	t_{d2}	0		60	ns
13.9	t_{hcs}	45			ns
13.10	t_{hlcs}	250			ns
13.11	t_{tri}			30	ns

- (1) The maximum SPI clock tolerance is ±10%.
- (2) Ensured by characterization.
- (3) Ensured by characterization.

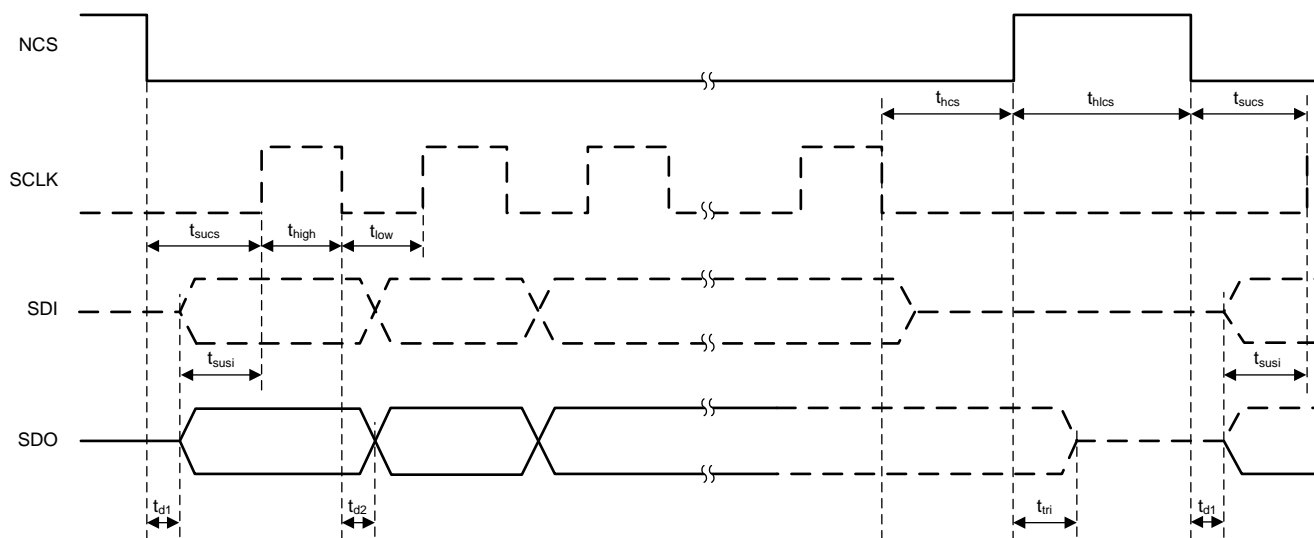
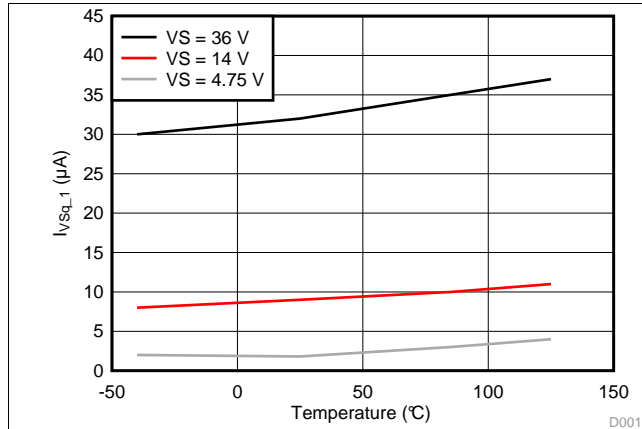
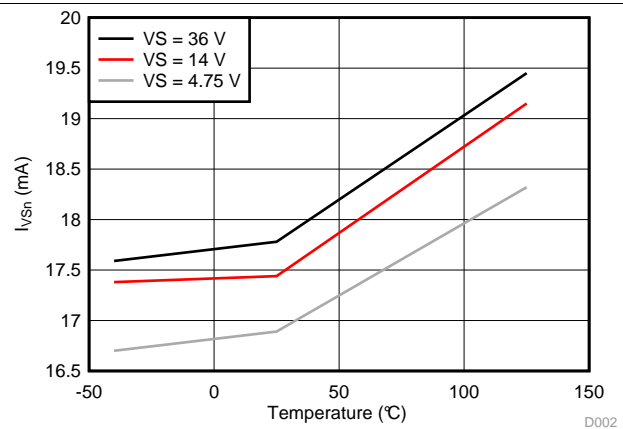

Figure 1. SPI Timing Parameters

6.7 Typical Characteristics

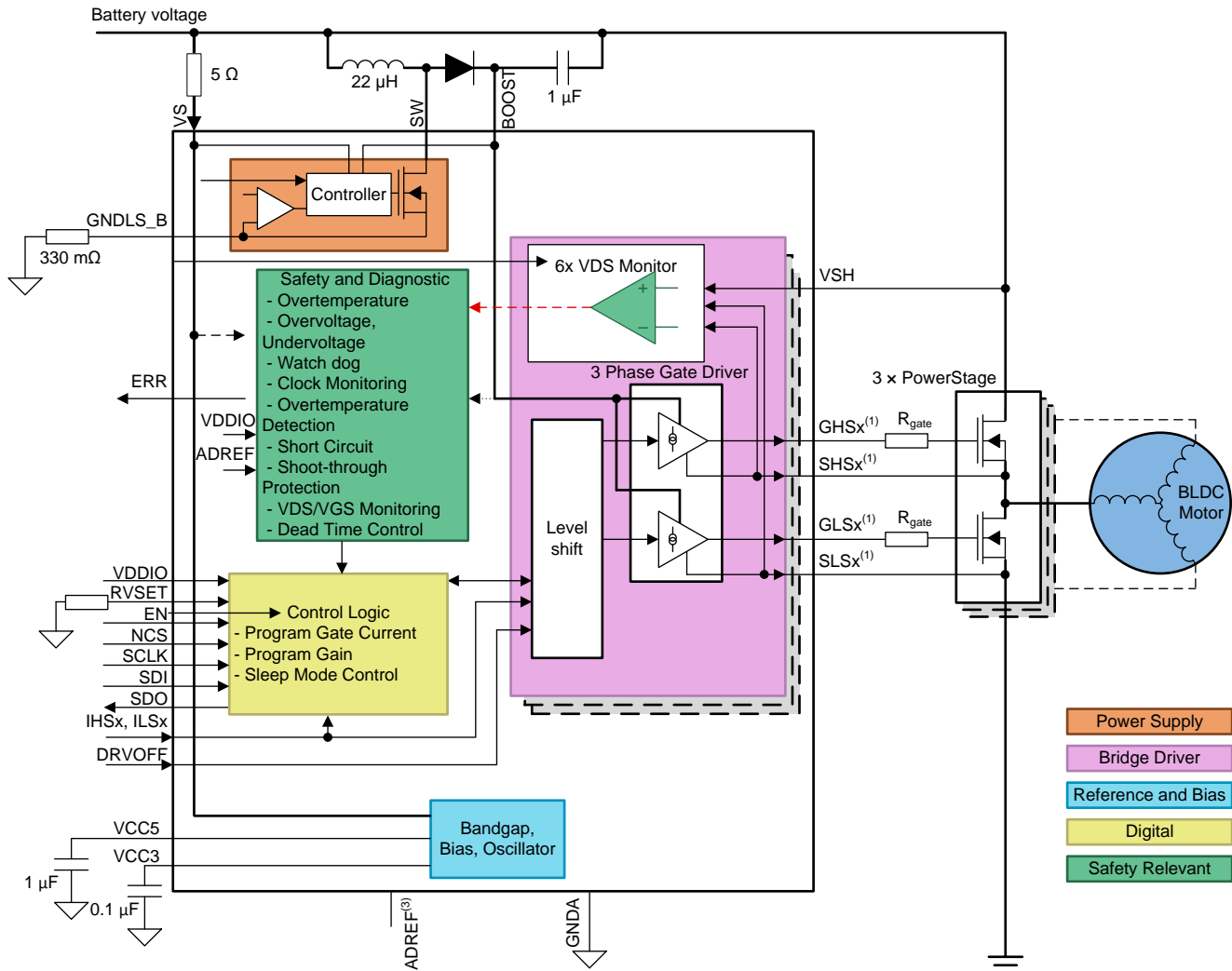

Figure 2. VS Quiescent Current Shutdown

Figure 3. VS Quiescent Current Shutdown

7 Detailed Description

7.1 Overview

The DRV3220-Q1 is designed to control 3-phase brushless DC motors in automotive applications using pulse-width modulation. Three high-side and three low-side gate drivers can be switched individually with low propagation delay. The input logic prevents simultaneous activation of the high-side and low-side driver of the same channel. A configuration and status register can be accessed through a SPI communication interface.

7.2 Functional Block Diagram



Copyright © 2017, Texas Instruments Incorporated

(1) x = 1, 2, 3

(2) y = 1, 2, 3

(3) An external reference voltage (VCC5 or VCC3) cannot be used for AREF voltage.

7.3 Programming

7.3.1 SPI

The SPI slave interface is used for serial communication with the external SPI master (external MCU). The SPI communication starts with the NCS falling edge and ends with NCS rising edge. The NCS high level keeps the SPI slave interface in reset state, and the SDO output in tri-state.

7.3.1.1 Address Mode Transfer

The address mode transfer is an 8-bit protocol. Both SPI slave and SPI master transmit the MSB first.

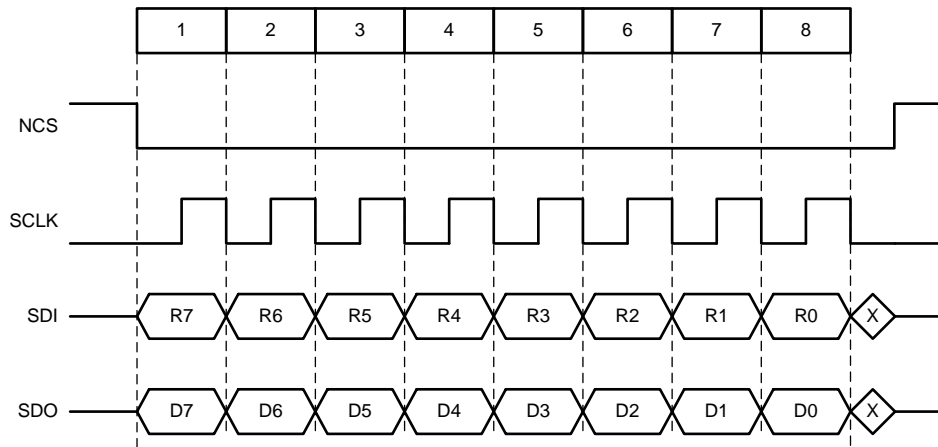

NOTE: SPI master (MCU) and SPI slave (DRV3220-Q1) sample received data on the falling SCLK edge and transmit on the rising SCLK edge.

Figure 4. Single 8-Bit SPI Frame/Transfer

After the NCS falling edge, the first word of 7 bits are address bits followed by the RW bit. During first address transfer, the device returns the STAT1 register on SDO.

Each complete 8-bit frame will be processed. If NCS goes high before a multiple of 8 bits is transferred, the bits are ignored.

7.3.1.1.1 SPI Address Transfer Phase

Figure 5. SPI Address Transfer Phase Bits

Bit	D7	D6	D5	D4	D3	D2	D1	D0
Function	ADDR6	ADDR5	ADDR4	ADDR3	ADDR2	ADDR1	ADDR0	RW

ADDR [6:0] Register address

RW Read and write access

RW = 0: Read access. The SPI master performs a read access to selected register. During following SPI transfer, the device returns the requested register read value on SDO, and device interprets SDI bits as a next address transfer.

RW = 1: Write access. The master performs a write access on the selected register. The slave updates the register value during next SPI transfer (if followed immediately) and returns the current register value on SDO.

7.3.1.2 SPI Data Transfer Phase

Figure 6. SPI Data Transfer Phase Bits

Bit	D7	D6	D5	D4	D3	D2	D1	D0
Function	DATA7	DATA6	DATA5	DATA4	ADDR3	DATA2	DATA1	DATA0

DATA [7:0] Data value for write access (8-Bit).

The table shows data value encoding scheme during a write access. It is possible to mix the two access modes (write and read access) during one SPI communication sequence (NCS = 0). The SPI communication can be terminated after single 8-bit SPI transfer by asserting NCS = 1. Device returns STAT1 register (for the very first SPI transfer after power-up) or current register value that was addressed during SPI Transfer Address Phase.

7.3.1.3 Device Data Response

Figure 7. Device Data Response Bits

Bit	D7	D6	D5	D4	D3	D2	D1	D0
Function	REG7	REG6	REG5	REG4	REG3	REG2	REG1	REG0

REG [7:0] Internal register value. All unused bits are set to 0.

Figure 8 shows a complete 16-bit SPI frame. Figure 9, Figure 10, Figure 11, Figure 12, Figure 13, and Figure 14 show the frame examples.

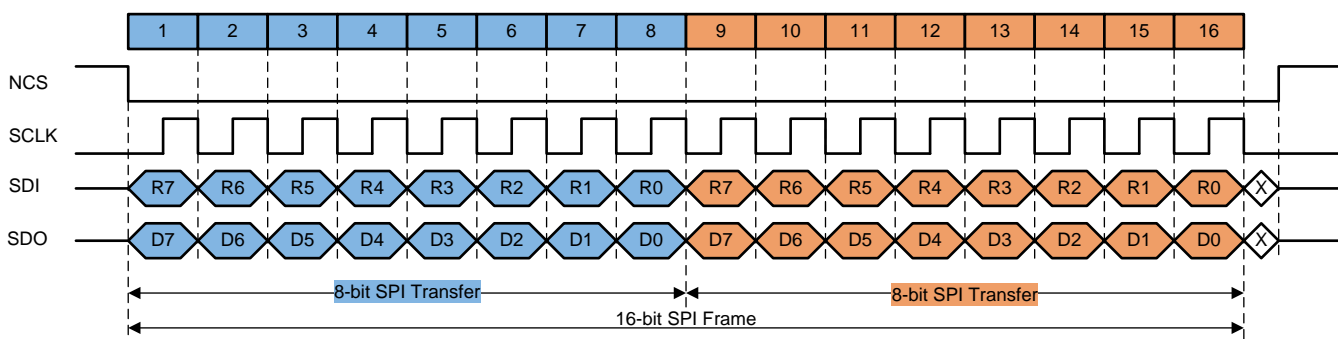

SPI Master (MCU) and SPI slave (DRV3220-Q1) sample received data on the rising SCLK edge, and transmit data on the falling SCLK edge

Figure 8. 16-Bit SPI Frame

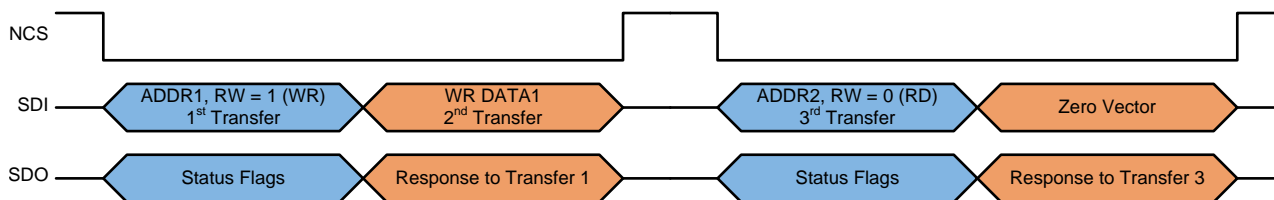

Figure 9. Write Access Followed by Read Access

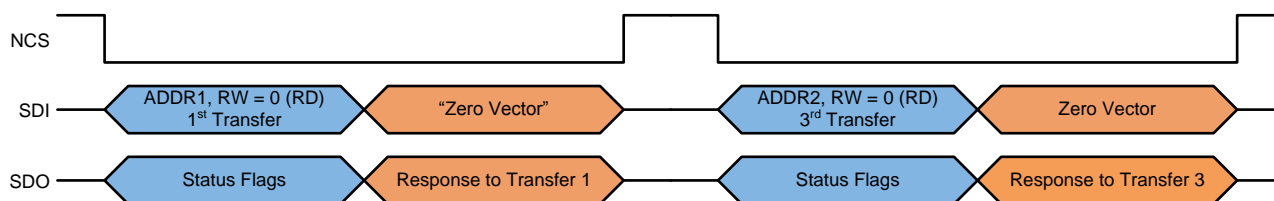

Figure 10. Read Access Followed by Read Access

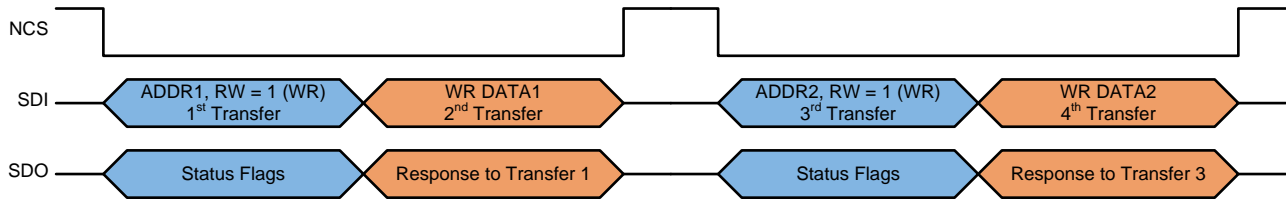

Figure 11. Write Access Followed by Write Access

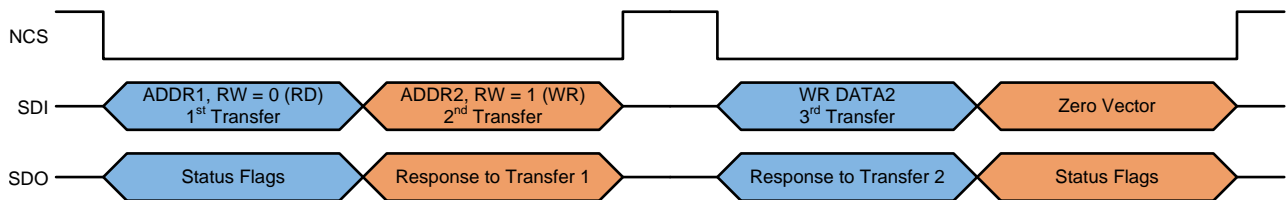

Figure 12. Read Access Followed by Write Access

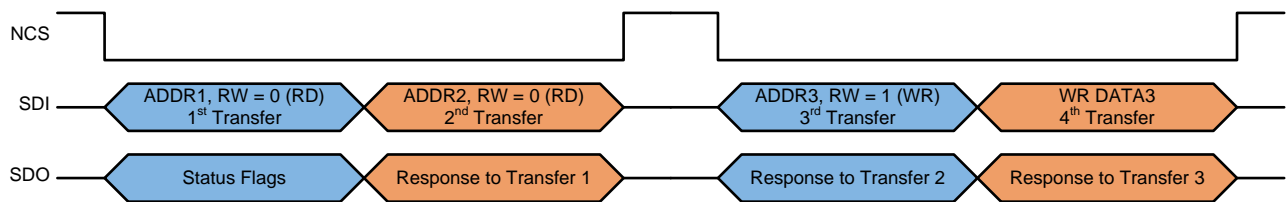

Figure 13. Read Access Followed by Read Access Followed by Write Access

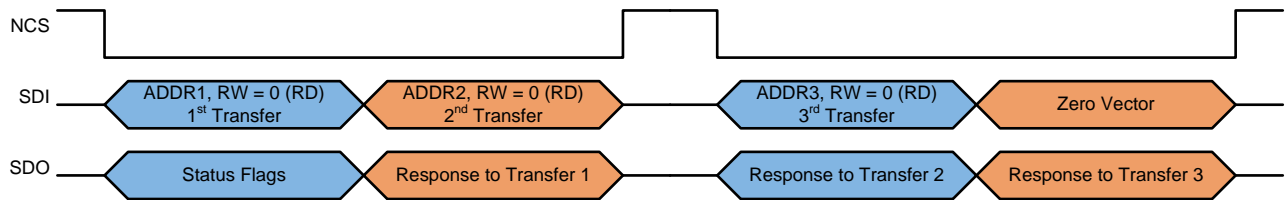

Figure 14. Read Access Followed by Read Access Followed by Read Access

7.4 Register Maps

Table 1. Register Address Map and Summary Table

Address	Name	Reset Value	CRC Check	Access State ⁽¹⁾	Reset Event ⁽²⁾ (bit wide exception)	Section
0x01	Configuration register 0 (CFG0)	8'h3F	Yes	W/R : D, A:[6:3] R : A[7,[2:0], SF	RST1-4	Go
0x02	Configuration register 1 (CFG1)	8'h3F	Yes	W/R: D R: A, SF	RST1-4	Go
0x04	HS 1/2/3 drive register (CURR0) ON	8'h00	Yes	W/R: D R: A, SF	RST1-4	Go
0x05	LS 1/2/3 drive register (CURR1) ON	8'h00	Yes	W/R: D R: A, SF	RST1-4	Go
0x06	HS 1/2/3 drive register (CURR2) OFF	8'h00	Yes	W/R: D R: A, SF	RST1-4	Go
0x07	LS 1/2/3 drive register (CURR3) OFF	8'h00	Yes	W/R: D R: A, SF	RST1-4	Go
0x08	Safety/error configuration register (SECR1)	8'hC0	Yes	W/R: D R: A, SF	RST1	Go
0x09	Safety function configuration register (SFCR1)	8'h80	Yes	W/R: D R: A, SF	RST1-3	Go
0x0A	Status register 0 (STAT0)	8'h00	No	R: D, A, SF	RST1-4	Go
0x0B	Status register 1 (STAT1)	8'h80	No	R: D, A, SF	RST1-3	Go
0x0C	Status register 2 (STAT2)	8'h00	No	R: D, A, SF	RST1-3	Go
0x0D	Status register 3 (STAT3)	8'h03	No	R: D, A, SF	RST1-3	Go
0x0E	Status register 4 (STAT4)	8'h00	No	R: D, A, SF	RST1-3	Go
0x0F	Status register 5 (STAT5)	8'h03	No	R: D, A, SF	RST1-3 (Bit[4]:RST1)	Go
0x10	Status register 6 (STAT6)	8'h00	No	R: D, A, SF	RST1-3	Go
0x11	Status register 7 (STAT7)	8'h00	No	R: D, A, SF	RST1-4	Go
0x12	Status register 8 (STAT8)	8'h00	No	R: D, A, SF	RST1-4 (Bit[0]:RST1)	Go
0x13	Safety error status (SAFETY_ERR_STAT)	8'h00	No	R: D, A, SF	RST1-3 (Bit[3:1]:RST1)	Go
0x14	Status register 9 (STAT9)	8'h00	No	R: D, A, SF	RST1-3	Go
0x15	Reserved 1	8'h00	No	W/R: D, A, SF	RST1-3	
0x16	Reserved 2	8'h00	No	W/R: D, A, SF	RST1-3	
0x1E	SPI transfer write CRC register (SPIWR_CRC)	8'h00	No	W/R: D, A, SF	RST1-3	Go
0x1F	SPI transfer read CRC register (SPIRD_CRC)	8'hFF	No	R: D, A, SF	RST1-3	Go
0x20	SAFETY_CHECK_CTRL register (SFCC1)	8'h01	No	W/R: D R: A, SF	RST1-3	Go
0x21	CRC control register (CRCCTL)	8'h00	No	W/R: D, A R: SF	RST1-3	Go
0x22	CRC calculated check sum register (CRCCALC)	N/A	No	W/R: D R: A, SF	RST1-3	Go
0x23	Reserved 3	8'h00	No	W/R: D, A, SF	RST1-3	
0x24	HS/LS read back (RB0)	8'h00	No	R: D, A, SF	RST1-3	Go
0x25	HS/LS count control (RB1)	8'h00	No	W/R: D, A R: SF	RST1-4	Go
0x26	HS/LS count (RB2)	8'h00	No	R: D, A, SF	RST1-4	Go
0x27	Configuration register 3 (CFG3)	8'hAB	Yes	W/R: D R: A, SF	RST1-4	Go

(1) W/R: Write and Read access possible, W: Write access possible, R: Read access possible

D: DIAGNOSTIC STATE, A: ACTIVE STATE, SF: SAFE STATE, SY: STANDBY STATE, R: RESET

(2) RST1: Power up, RST2: System clock error detected by clock monitor RST3: VCC3 UV/OV or from other state to RESET, RST4: LBI

Register Maps (continued)
Table 1. Register Address Map and Summary Table (continued)

Address	Name	Reset Value	CRC Check	Access State ⁽¹⁾	Reset Event ⁽²⁾ (bit wide exception)	Section
0x28	Configuration register 4 (CFG4)	8'h00	Yes	W/R: D R: A, SF	RST1-4	Go
0x29	Configuration register 5 (CFG5)	8'hAB	Yes	W/R: D R: A, SF	RST1-3	Go
0x2A	CSM unlock (CSM_UNLOCK1)	8'h00	No	W/R: D R: A, SF	RST1-4	Go
0x2B	CSM unlock (CSM_UNLOCK2)	8'h3F	No	W/R: D R: A, SF	RST1-4	Go
0x2C	Reserved 4	8'h00	Yes	W/R: D R: A, SF	RST1-4	
0x2D	Safety BIST control register 1 (SAFETY_BIST_CTL1)	8'h00	Yes	W/R: D R: SF, A	RST1-3	Go
0x2E	SPI test register (SPI_TEST)	8'h00	No	W/R: D, A, SF	RST1-4	Go
0x2F	Reserved 5	8'h00	No	W/R: D, A, SF	RST1-3	
0x30	Safety BIST control register 2 (SAFETY_BIST_CTL2)	8'h00	Yes	W/R: D R: SF, A	RST1-3 (Bit[5]:RST1)	Go
0x31	Watch dog timer configuration register (WDT_WIN1_CFG)	8'h02	Yes	W/R: D R: SF, A	RST1-4	Go
0x32	Watch dog timer configuration register (WDT_WIN2_CFG)	8'h08	Yes	W/R: D R: SF, A	RST1-4	Go
0x33	Watch dog timer TOKEN register (WDT_TOKEN_FDBCK)	8'h04	Yes	W/R: D R: SF, A	RST1	Go
0x34	Watch dog timer TOKEN register (WDT_TOKEN_VALUE)	8'h40	No	R: D, SF, A	RST1-4	Go
0x35	Watch dog timer ANSWER register (WDT_ANSWER)	8'h00	No	W/R: D, A, SF	RST1-4	Go
0x36	Watch dog timer status register (WDT_STATUS)	8'hC0	No	R: D, A, SG	RST1-4	Go
0x37	Watch dog failure detection configuration register (WD_FAIL_CFG)	8'hEC	Yes	W/R: D R: SF, A	RST1-4	Go
0x38	Configuration register 6 (CFG6)	8'h10	Yes	W/R: D R: A, SF	RST1-4	Go
0x39	Configuration register 7 (CFG7)	8'h13	Yes	W/R: D R: A, SF	RST1-4	Go
0x3A	Configuration register 8 (CFG8)	8'h20	Yes	W/R: D R: A, SF	RST1-4	Go
0x3B	Reserved 6	0	—	—	—	

8 Application and Implementation

NOTE

Information in the following applications sections is not part of the TI component specification, and TI does not warrant its accuracy or completeness. TI's customers are responsible for determining suitability of components for their purposes. Customers should validate and test their design implementation to confirm system functionality.

8.1 Application Information

The DRV3220-Q1 is a predriver for automotive applications featuring three-phase brushless DC-motor control. Because this device has a boost regulator for charging high-side gates, it can handle gate charges of 250 nC. A boost converter allows full control on the power-stages even for a low battery voltage down to 4.75 V.

8.2 Typical Application

8.2.1 Three-Phase Motor Drive-Device for Automotive Application

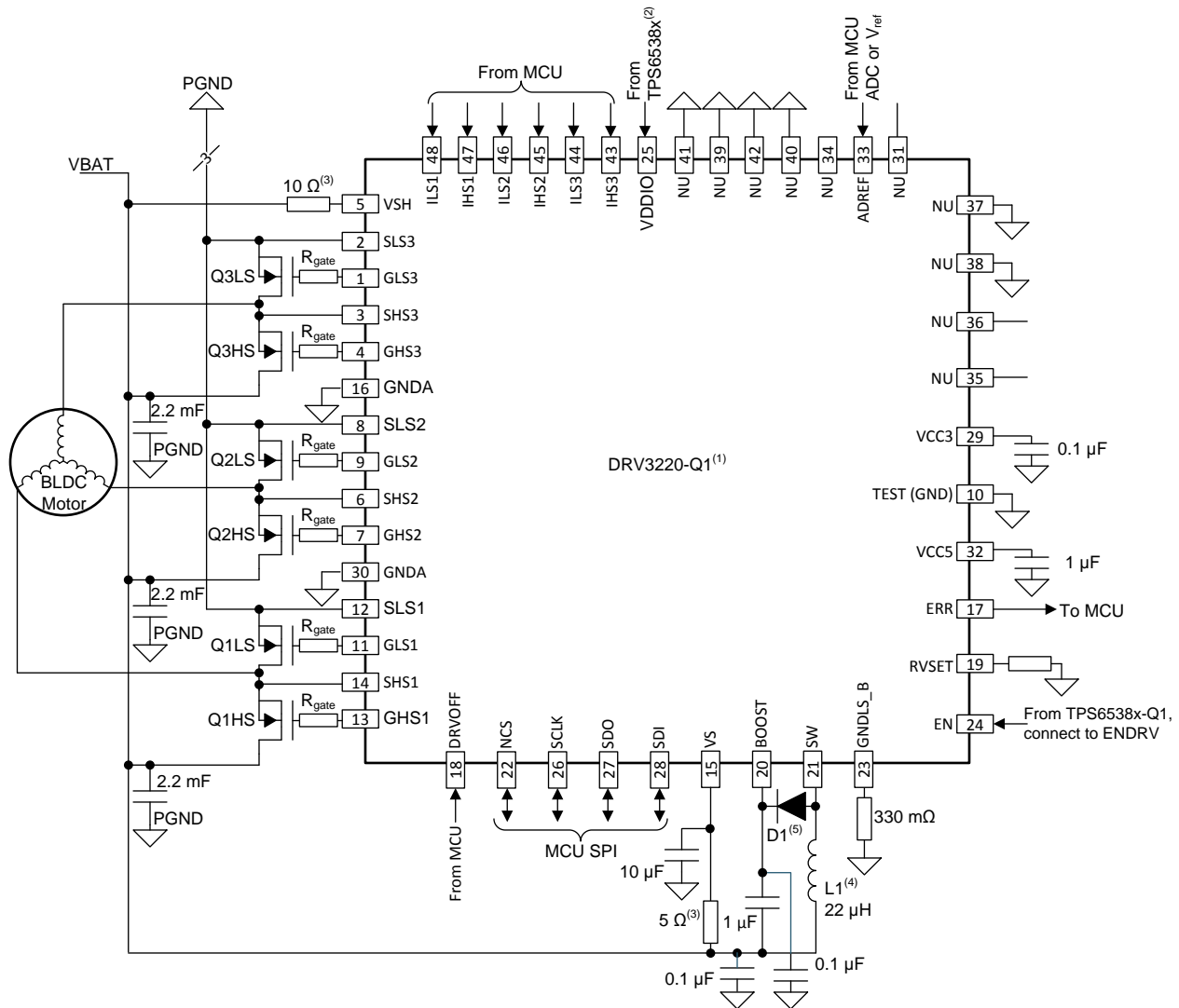

Copyright © 2017, Texas Instruments Incorporated

- (1) This schematic of the DRV3220-Q1 48-pin HTQFP does not provide a true representation of physical pin locations.
- (2) Use same supply from the TPS6538x as the supply used for the MCU IO.
- (3) Resistor not required for reverse protected battery.
- (4) L1 = B82442A1223K000 INDUCTOR, SMT, 22 uH, 10%, 480 mA). The maximum inductor current must be more than VGNDLS_B / 330 mΩ.
- (5) D1 = SS28 (DIODE, SMT, SCHOTTKY, 80 V, 2 A). A fast recovery diode is recommended.
- (6) QxHS, QxLS = IRFS3004PBF (HEXFET, N-CHANNEL, POWER MOSFET, D2PACK)
- (7) R_{gate} = Must be adjust based on system requirement such as EMI, Slew rate, and power

Figure 15. Typical Application Diagram

8.3 System Example

Figure 16 shows a typical system example for an electric power-steering system.

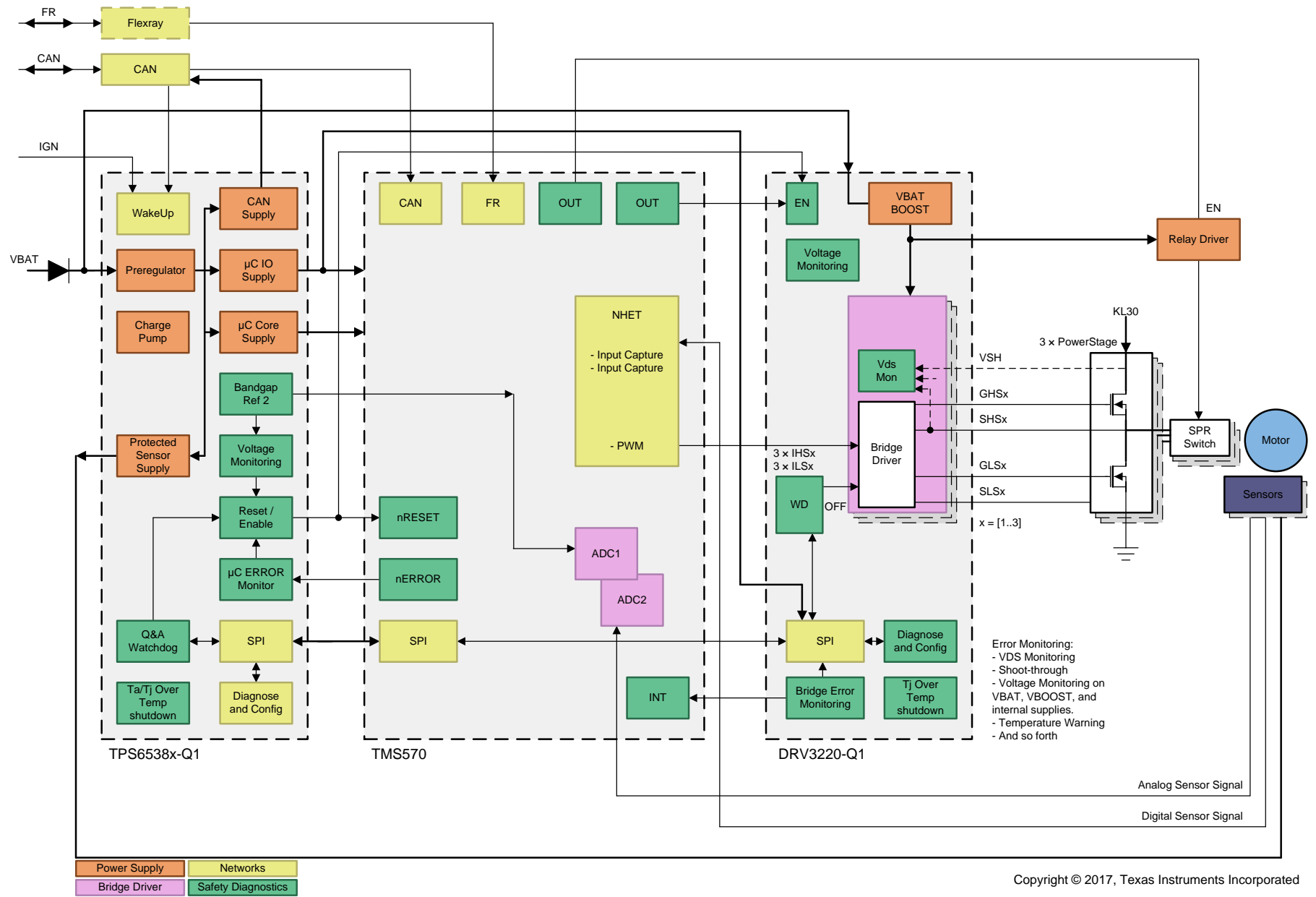

Figure 16. Typical System – Electrical Power Steering Example

9 Power Supply Recommendations

The device is designed to operate from an input voltage supply range of 4.75 V to 40 V. The protection circuit must be placed for protection against reverse supply connection.

10 Layout

10.1 Layout Guidelines

Use the following guidelines when designing a PCB for the DRV3220-Q1:

- In addition to the GND pins, the DRV3220-Q1 makes an electrical connection to GND through the PowerPAD. Always check that the PowerPAD has been properly soldered (see *PowerPAD™ Thermally Enhanced Package* [SLMA002]).
- The VS bypass capacitors should be placed close to the power supply terminals. See the VS box in [Figure 17](#)
- Place the VCC5 and VCC5 bypass capacitors close to the corresponding pins with a low impedance path to the ground plane pin (pin 16). See the VCC3 VCC5 bypass box in [Figure 17](#).
- AGND should all be tied to the ground plane through a low impedance trace or copper fill.
- Add stitching vias to reduce the impedance of the GND path from the top to bottom side.
- Try to clear the space around and below the DRV3220-Q1 to allow for better heat spreading from the PowerPAD.
- Keep the BOOST components close to the device and current loops small. See the BOOST boxes in [Figure 17](#).
- Place the GNDLS_B resistor close to the device pin. See the GNDLS_B box in [Figure 17](#).

10.2 Layout Example

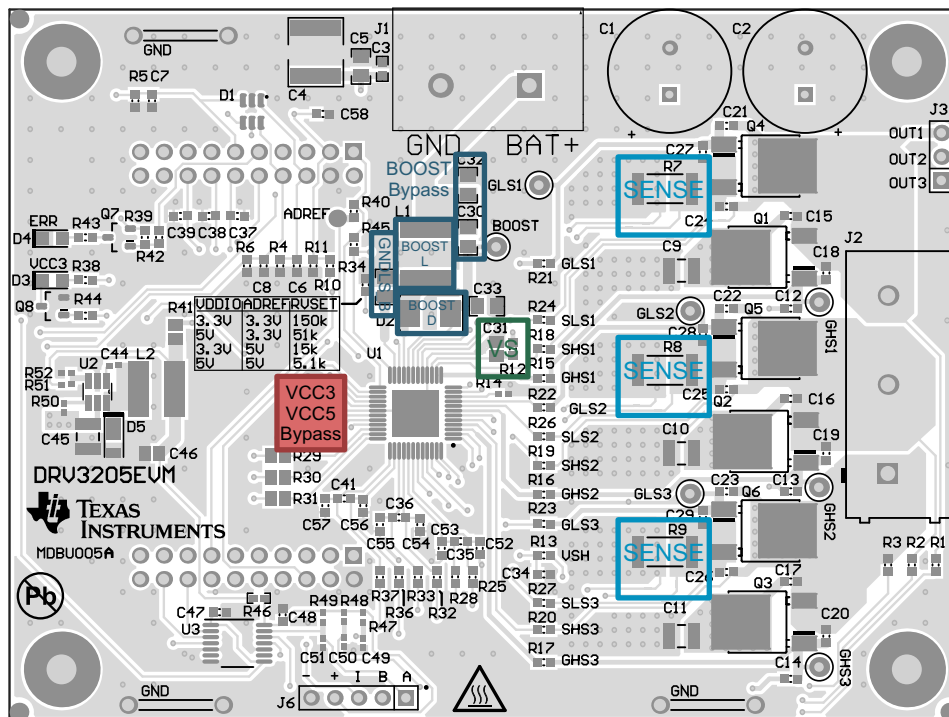

Figure 17. Layout Schematic

11 Device and Documentation Support

11.1 Documentation Support

11.1.1 Related Documentation

For related documentation see the following:

- [DRV3220-Q1 Applications in 24-V Automotive Systems](#)
- [DRV3220-Q1 Negative Voltage Stress on Source Pins](#)
- [Electric Power Steering Design Guide with DRV3220-Q1](#)
- [PowerPAD™ Thermally Enhanced Package](#)
- [Protecting Automotive Motor Drive Systems from Reverse Polarity Conditions](#)
- [Q&A Watchdog Timer Configuration for DRV3220-Q1](#)
- [TPS653850-Q1 Multirail Power Supply for Microcontrollers in Safety-Relevant Applications](#)
- [TPS653853-Q1 Multirail Power Supply for Microcontrollers in Safety-Relevant Applications](#)

11.2 Receiving Notification of Documentation Updates

To receive notification of documentation updates, navigate to the device product folder on ti.com. In the upper right corner, click on *Alert me* to register and receive a weekly digest of any product information that has changed. For change details, review the revision history included in any revised document.

11.3 Community Resources

The following links connect to TI community resources. Linked contents are provided "AS IS" by the respective contributors. They do not constitute TI specifications and do not necessarily reflect TI's views; see TI's [Terms of Use](#).

TI E2E™ Online Community *TI's Engineer-to-Engineer (E2E) Community*. Created to foster collaboration among engineers. At e2e.ti.com, you can ask questions, share knowledge, explore ideas and help solve problems with fellow engineers.

Design Support *TI's Design Support* Quickly find helpful E2E forums along with design support tools and contact information for technical support.

11.4 Trademarks

PowerPAD, E2E are trademarks of Texas Instruments.
All other trademarks are the property of their respective owners.

11.5 Electrostatic Discharge Caution



This integrated circuit can be damaged by ESD. Texas Instruments recommends that all integrated circuits be handled with appropriate precautions. Failure to observe proper handling and installation procedures can cause damage.

ESD damage can range from subtle performance degradation to complete device failure. Precision integrated circuits may be more susceptible to damage because very small parametric changes could cause the device not to meet its published specifications.

11.6 Glossary

[SLYZ022](#) — *TI Glossary*.

This glossary lists and explains terms, acronyms, and definitions.

12 Mechanical, Packaging, and Orderable Information

The following pages include mechanical, packaging, and orderable information. This information is the most current data available for the designated devices. This data is subject to change without notice and revision of this document. For browser-based versions of this data sheet, refer to the left-hand navigation.

PACKAGING INFORMATION

Orderable Device	Status (1)	Package Type	Package Drawing	Pins	Package Qty	Eco Plan (2)	Lead finish/ Ball material (6)	MSL Peak Temp (3)	Op Temp (°C)	Device Marking (4/5)	Samples
DRV3220QPHPRQ1	ACTIVE	HTQFP	PHP	48	1000	RoHS & Green	NIPDAU	Level-3-260C-168 HR	-40 to 125	DRV3220Q1	Samples

(1) The marketing status values are defined as follows:

ACTIVE: Product device recommended for new designs.

LIFEBUY: TI has announced that the device will be discontinued, and a lifetime-buy period is in effect.

NRND: Not recommended for new designs. Device is in production to support existing customers, but TI does not recommend using this part in a new design.

PREVIEW: Device has been announced but is not in production. Samples may or may not be available.

OBSOLETE: TI has discontinued the production of the device.

(2) **RoHS:** TI defines "RoHS" to mean semiconductor products that are compliant with the current EU RoHS requirements for all 10 RoHS substances, including the requirement that RoHS substance do not exceed 0.1% by weight in homogeneous materials. Where designed to be soldered at high temperatures, "RoHS" products are suitable for use in specified lead-free processes. TI may reference these types of products as "Pb-Free".

RoHS Exempt: TI defines "RoHS Exempt" to mean products that contain lead but are compliant with EU RoHS pursuant to a specific EU RoHS exemption.

Green: TI defines "Green" to mean the content of Chlorine (Cl) and Bromine (Br) based flame retardants meet JS709B low halogen requirements of <=1000ppm threshold. Antimony trioxide based flame retardants must also meet the <=1000ppm threshold requirement.

(3) MSL, Peak Temp. - The Moisture Sensitivity Level rating according to the JEDEC industry standard classifications, and peak solder temperature.

(4) There may be additional marking, which relates to the logo, the lot trace code information, or the environmental category on the device.

(5) Multiple Device Markings will be inside parentheses. Only one Device Marking contained in parentheses and separated by a "-" will appear on a device. If a line is indented then it is a continuation of the previous line and the two combined represent the entire Device Marking for that device.

(6) Lead finish/Ball material - Orderable Devices may have multiple material finish options. Finish options are separated by a vertical ruled line. Lead finish/Ball material values may wrap to two lines if the finish value exceeds the maximum column width.

Important Information and Disclaimer: The information provided on this page represents TI's knowledge and belief as of the date that it is provided. TI bases its knowledge and belief on information provided by third parties, and makes no representation or warranty as to the accuracy of such information. Efforts are underway to better integrate information from third parties. TI has taken and continues to take reasonable steps to provide representative and accurate information but may not have conducted destructive testing or chemical analysis on incoming materials and chemicals. TI and TI suppliers consider certain information to be proprietary, and thus CAS numbers and other limited information may not be available for release.

In no event shall TI's liability arising out of such information exceed the total purchase price of the TI part(s) at issue in this document sold by TI to Customer on an annual basis.

GENERIC PACKAGE VIEW

PHP 48

TQFP - 1.2 mm max height

7 x 7, 0.5 mm pitch

QUAD FLATPACK

This image is a representation of the package family, actual package may vary.
Refer to the product data sheet for package details.

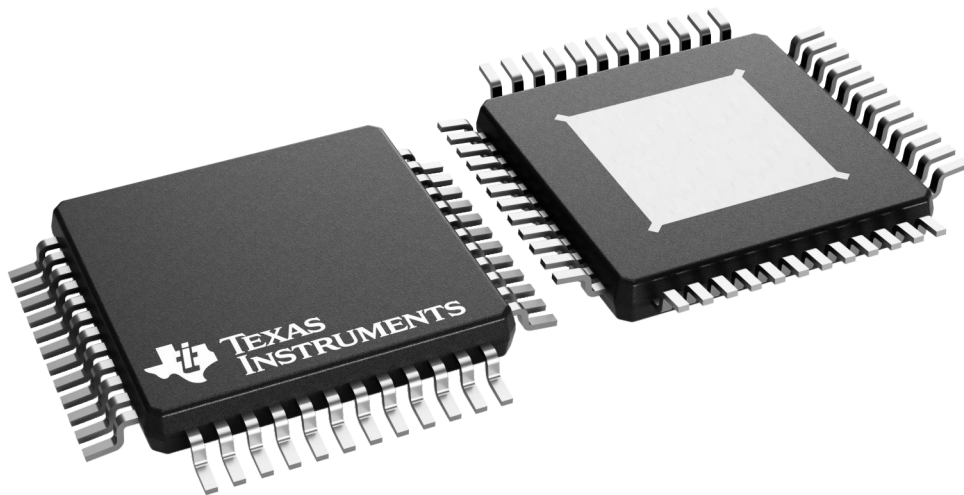

4226443/A

EXAMPLE BOARD LAYOUT

PHP0048G

PowerPAD™ HTQFP - 1.2 mm max height

PLASTIC QUAD FLATPACK

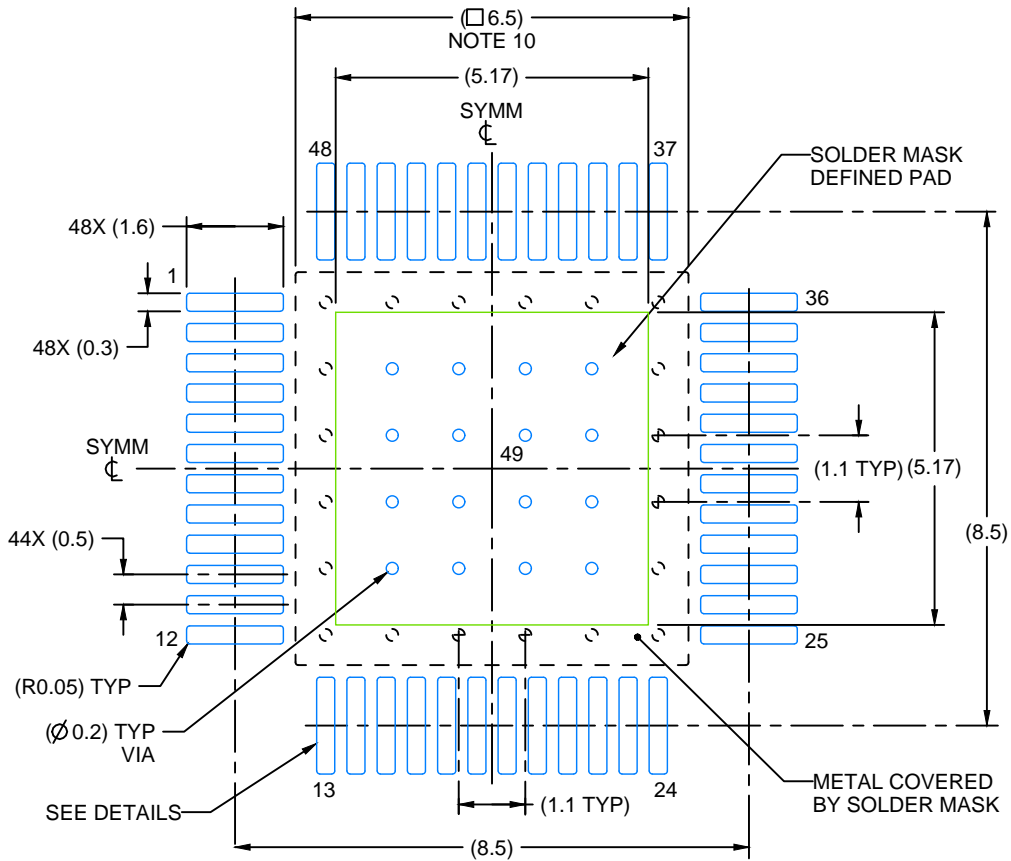

LAND PATTERN EXAMPLE
EXPOSED METAL SHOWN
SCALE:8X

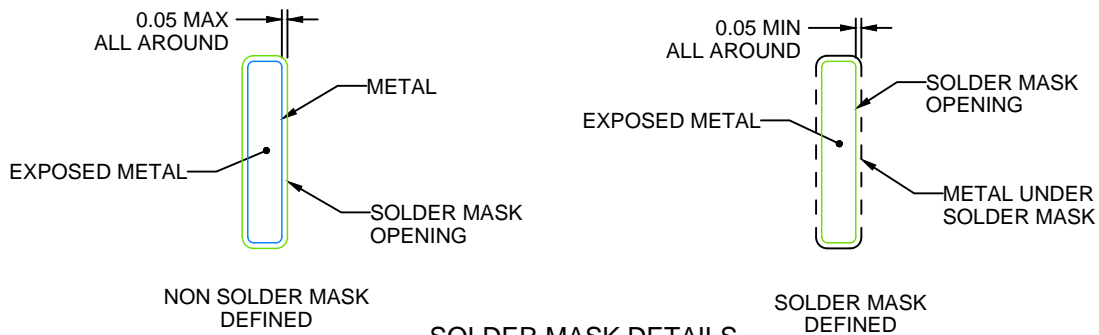

SOLDER MASK DETAILS

4225861/A 4/2020

NOTES: (continued)

6. Publication IPC-7351 may have alternate designs.
7. Solder mask tolerances between and around signal pads can vary based on board fabrication site.
8. This package is designed to be soldered to a thermal pad on the board. See technical brief, Powerpad thermally enhanced package, Texas Instruments Literature No. SLMA002 (www.ti.com/lit/slma002) and SLMA004 (www.ti.com/lit/slma004).
9. Vias are optional depending on application, refer to device data sheet. It is recommended that vias under paste be filled, plugged or tented.
10. Size of metal pad may vary due to creepage requirement.

EXAMPLE STENCIL DESIGN

PHP0048G

PowerPAD™ HTQFP - 1.2 mm max height

PLASTIC QUAD FLATPACK

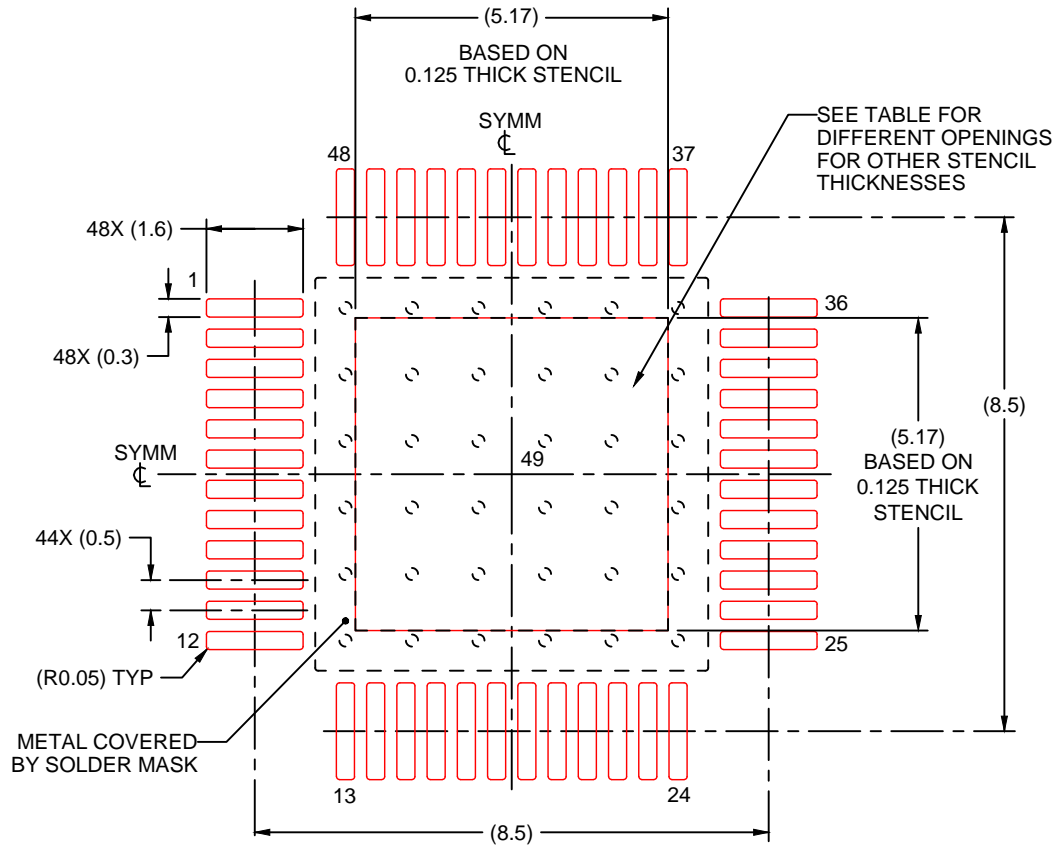

SOLDER PASTE EXAMPLE
EXPOSED PAD
100% PRINTED SOLDER COVERAGE BY AREA
SCALE:8X

STENCIL THICKNESS	SOLDER STENCIL OPENING
0.1	5.78 X 5.78
0.125	5.17 X 5.17 (SHOWN)
0.150	4.72 X 4.72
0.175	4.37 X 4.37

4225861/A 4/2020

NOTES: (continued)

11. Laser cutting apertures with trapezoidal walls and rounded corners may offer better paste release. IPC-7525 may have alternate design recommendations.
12. Board assembly site may have different recommendations for stencil design.

IMPORTANT NOTICE AND DISCLAIMER

TI PROVIDES TECHNICAL AND RELIABILITY DATA (INCLUDING DATA SHEETS), DESIGN RESOURCES (INCLUDING REFERENCE DESIGNS), APPLICATION OR OTHER DESIGN ADVICE, WEB TOOLS, SAFETY INFORMATION, AND OTHER RESOURCES "AS IS" AND WITH ALL FAULTS, AND DISCLAIMS ALL WARRANTIES, EXPRESS AND IMPLIED, INCLUDING WITHOUT LIMITATION ANY IMPLIED WARRANTIES OF MERCHANTABILITY, FITNESS FOR A PARTICULAR PURPOSE OR NON-INFRINGEMENT OF THIRD PARTY INTELLECTUAL PROPERTY RIGHTS.

These resources are intended for skilled developers designing with TI products. You are solely responsible for (1) selecting the appropriate TI products for your application, (2) designing, validating and testing your application, and (3) ensuring your application meets applicable standards, and any other safety, security, regulatory or other requirements.

These resources are subject to change without notice. TI grants you permission to use these resources only for development of an application that uses the TI products described in the resource. Other reproduction and display of these resources is prohibited. No license is granted to any other TI intellectual property right or to any third party intellectual property right. TI disclaims responsibility for, and you will fully indemnify TI and its representatives against, any claims, damages, costs, losses, and liabilities arising out of your use of these resources.

TI's products are provided subject to [TI's Terms of Sale](#) or other applicable terms available either on ti.com or provided in conjunction with such TI products. TI's provision of these resources does not expand or otherwise alter TI's applicable warranties or warranty disclaimers for TI products.

TI objects to and rejects any additional or different terms you may have proposed.

Mailing Address: Texas Instruments, Post Office Box 655303, Dallas, Texas 75265
Copyright © 2021, Texas Instruments Incorporated