

# TPS65268-Q1 4V 至 8V、3A、2A、2A 三路同步降压转换器

## 1 特性

- 符合汽车类应用要求
- 具有符合 AEC-Q100 标准的下列特性：
  - 器件温度 1 级：-40°C 至 +125°C 的工作结温范围
  - 器件 HBM ESD 分类等级 2
  - 器件 CDM ESD 分类等级 C4B
- 工作输入电压范围 4V 至 8V，最大连续输出电流 3A、2A、2A
- 反馈基准电压为 0.6V ±1%
- 可调节时钟频率范围为 200kHz 至 2.3MHz
- 强制连续电流模式 (FCCM)
- 外部时钟同步
- 针对每次降压的专用使能引脚和软启动引脚
- 输出电压电源正常状态指示器
- 热过载保护

## 2 应用

- 汽车
- 汽车音频和视频
- 家庭网关和接入点网络
- 安全监控

## 3 说明

TPS65268-Q1 器件包含三路同步降压转换器，并具有 4V 至 8V 的宽输入电压范围。这款转换器具有恒定频率峰值电流模式，专用于简化应用，同时方便设计人员根据目标应用来优化系统。可通过外部电阻在 200kHz 至 2.3MHz 范围内调节转换器的开关频率。BUCK1 与 BUCK2 和 BUCK3 之间呈 180° 异相运行 (BUCK2 和 BUCK3 同相位运行) 最大限度地降低了输入滤波器要求。

TPS65268-Q1 器件中的每个降压转换器在轻负载条件下均以强制连续电流模式 (FCCM) 运行，以降低输出电压纹波，提高负载瞬态响应。

TPS65268-Q1 器件具有过压、过流、短路和过热保护。

器件信息(1)

器件型号	封装	封装尺寸 (标称值)
TPS65268-Q1	VQFN (32)	5.00mm × 5.00mm

(1) 要了解所有可用封装，请见数据表末尾的可订购产品附录。

应用原理图

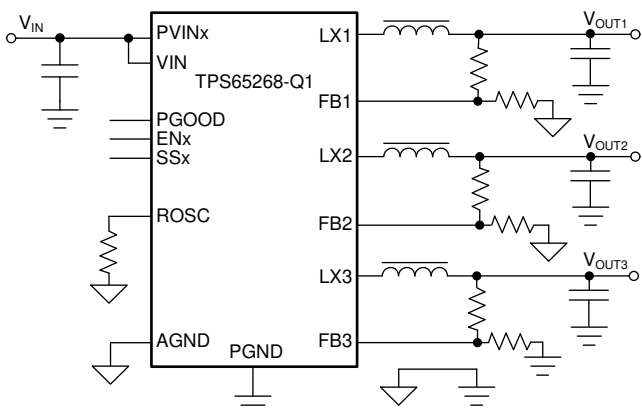

Copyright © 2017, Texas Instruments Incorporated

效率与输出负载之间的关系

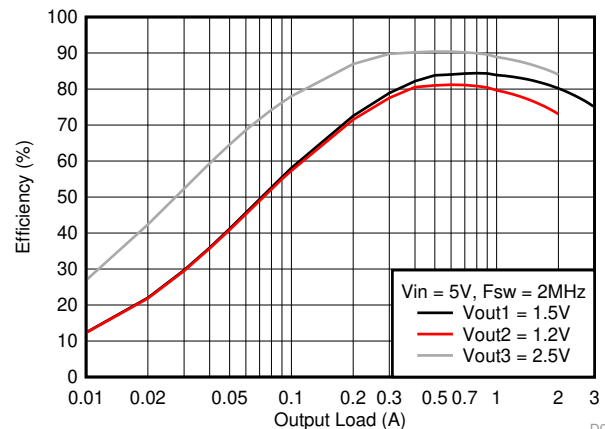

D001



## 目录

<b>1</b>	特性 .....	<b>1</b>	7.3	Feature Description .....	<b>13</b>
<b>2</b>	应用 .....	<b>1</b>	7.4	Device Functional Modes .....	<b>22</b>
<b>3</b>	说明 .....	<b>1</b>	<b>8</b>	<b>Application and Implementation</b> .....	<b>23</b>
<b>4</b>	修订历史记录 .....	<b>2</b>	8.1	Application Information .....	<b>23</b>
<b>5</b>	<b>Pin Configuration and Functions</b> .....	<b>3</b>	8.2	Typical Application .....	<b>23</b>
<b>6</b>	<b>Specifications</b> .....	<b>5</b>	<b>9</b>	<b>Power Supply Recommendations</b> .....	<b>31</b>
6.1	Absolute Maximum Ratings .....	<b>5</b>	<b>10</b>	<b>Layout</b> .....	<b>31</b>
6.2	ESD Ratings .....	<b>5</b>	10.1	Layout Guidelines .....	<b>31</b>
6.3	Recommended Operating Conditions .....	<b>5</b>	10.2	Layout Example .....	<b>32</b>
6.4	Thermal Information .....	<b>5</b>	<b>11</b>	<b>器件和文档支持</b> .....	<b>33</b>
6.5	Electrical Characteristics .....	<b>6</b>	11.1	接收文档更新通知 .....	<b>33</b>
6.6	Timing Requirements .....	<b>7</b>	11.2	社区资源 .....	<b>33</b>
6.7	Typical Characteristics .....	<b>8</b>	11.3	商标 .....	<b>33</b>
<b>7</b>	<b>Detailed Description</b> .....	<b>12</b>	11.4	静电放电警告 .....	<b>33</b>
7.1	Overview .....	<b>12</b>	11.5	Glossary .....	<b>33</b>
7.2	Functional Block Diagram .....	<b>13</b>	<b>12</b>	<b>机械、封装和可订购信息</b> .....	<b>33</b>

## 4 修订历史记录

注：之前版本的页码可能与当前版本有所不同。

<b>Changes from Revision A (January 2018) to Revision B</b>	<b>Page</b>
• 已更改 <a href="#">图 52</a> thermal signature .....	<b>30</b>

<b>Changes from Original (January 2018) to Revision A</b>	<b>Page</b>
• Changed the maximum value for the BUCK2/BUCK3 peak inductor current limit parameter from 3.9 A to 4 A in the <i>Electrical Characteristics</i> table .....	<b>6</b>
• 已更改 the unit for soft start current from mA to $\mu$ A in the <i>SS Pin Charge Current vs Temperature</i> graph .....	<b>9</b>

## 5 Pin Configuration and Functions

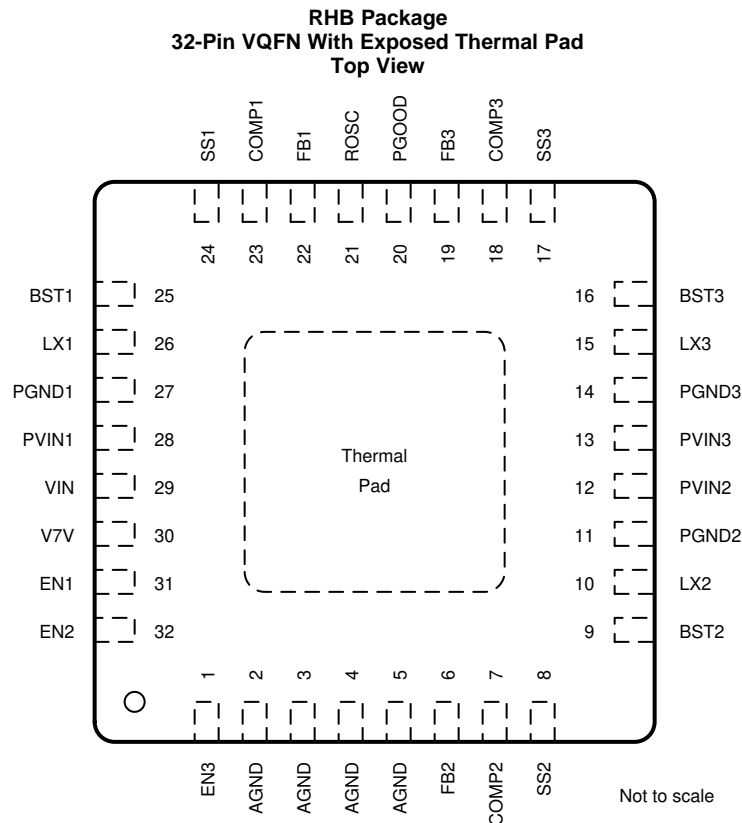

No electric signal is down bonded to thermal pad inside the device. Exposed thermal pad must be soldered to PCB for optimal thermal performance.

### Pin Functions

PIN		TYPE <sup>(1)</sup>	DESCRIPTION
NO.	NAME		
1	EN3	I	Enable for BUCK3. Float to enable. Use this pin to adjust the UVLO input voltage of BUCK3 with a resistor divider.
2	AGND	G	Analog ground common to buck controllers and other analog circuits. This pin must be routed separately from high-current power grounds to the negative pin of bypass capacitor of input voltage ( $V_{IN}$ ).
3			
4			
5			
6	FB2	I	Feedback Kelvin sensing pin for BUCK2 output voltage. Connect this pin to the BUCK2 resistor divider.
7	COMP2	O	Error amplifier output and loop compensation pin for BUCK2. Connect a series resistor and capacitor to compensate the control loop of BUCK2 with peak-current PWM mode.
8	SS2	O	Soft-start and tracking input for BUCK2. An internal 5.2- $\mu$ A pullup current source is connected to this pin. The soft-start time can be programmed by connecting a capacitor between this pin and ground.
9	BST2	O	Boot-strapped supply to the high-side floating gate driver in BUCK2. Connect a capacitor (recommended value of 47 nF) from the BST2 pin to LX2 pin.
10	LX2	O	Switching node connection to the inductor and bootstrap capacitor for BUCK2. The voltage swing at this pin is from a diode voltage below the ground up to the PVIN2 voltage.
11	PGND2	G	Power ground connection of BUCK2. Connect the PGND2 pin as close as possible to the negative pin of VIN2 input ceramic capacitor.
12	PVIN2	P	Input power supply for BUCK2. Connect the PVIN2 pin as close as possible to the positive pin of an input ceramic capacitor (recommended value of 10 $\mu$ F).

(1) I = Input, O = Output, P = Supply, G = Ground

**Pin Functions (continued)**

PIN		TYPE <sup>(1)</sup>	DESCRIPTION
NO.	NAME		
13	PVIN3	P	Input power supply for BUCK3. Connect the PVIN3 pin as close as possible to the positive pin of an input ceramic capacitor (recommended value of 10 $\mu$ F).
14	PGND3	G	Power ground connection of BUCK3. Connect the PGND3 pin as close as possible to the negative pin of the VIN3 input ceramic capacitor.
15	LX3	O	Switching node connection to the inductor and bootstrap capacitor for BUCK3. The voltage swing at this pin is from a diode voltage below the ground up to the PVIN3 voltage.
16	BST3	O	Boot-strapped supply to the high-side floating gate driver in BUCK3. Connect a capacitor (recommended value of 47 nF) from the BST3 pin to LX3 pin.
17	SS3	O	Soft-start and tracking input for BUCK3. An internal 5.2- $\mu$ A pullup current source is connected to this pin. The soft-start time can be programmed by connecting a capacitor between this pin and ground.
18	COMP3	O	Error amplifier output and loop compensation pin for BUCK3. Connect a series resistor and capacitor to compensate the control loop of BUCK3 with peak-current PWM mode.
19	FB3	I	Feedback Kelvin sensing pin for BUCK3 output voltage. Connect this pin to the BUCK3 resistor divider.
20	PGOOD	O	Output voltage supervision pin. When all buck converters are in the regulation range of the PGOOD monitor, the PGOOD pin is asserted high.
21	ROSC	O	Clock frequency adjustment pin. Connect a resistor from this pin to ground to adjust the clock frequency. When connected to an external clock, the internal oscillator synchronizes to the external clock.
22	FB1	I	Feedback Kelvin sensing pin for BUCK1 output voltage. Connect this pin to the BUCK1 resistor divider.
23	COMP1	O	Error amplifier output and loop compensation pin for BUCK1. Connect a series resistor and capacitor to compensate the control loop of BUCK1 with peak current PWM mode.
24	SS1	O	Soft-start and tracking input for BUCK1. An internal 5.2- $\mu$ A pullup current source is connected to this pin. The soft-start time can be programmed by connecting a capacitor between this pin and ground.
25	BST1	O	Boot-strapped supply to the high-side floating gate driver in BUCK1. Connect a capacitor (recommended value of 47 nF) from the BST1 pin to LX1 pin.
26	LX1	O	Switching node connection to the inductor and bootstrap capacitor for BUCK1. The voltage swing at this pin is from a diode voltage below the ground up to the PVIN1 voltage.
27	PGND1	G	Power ground connection of BUCK1. Connect the PGND1 pin as close as possible to the negative pin of PVIN1 input ceramic capacitor.
28	PVIN1	P	Input power supply for BUCK1. Connect the PVIN1 pin as close as possible to the positive pin of an input ceramic capacitor (suggest 10 $\mu$ F).
29	VIN	P	Buck controller power supply
30	V7V	O	Internal LDO regulator for gate driver and internal controller. Connect a 1- $\mu$ F capacitor from the pin to power ground.
31	EN1	I	Enable for BUCK1. Float to enable. Use this pin to adjust the UVLO input voltage of BUCK1 with a resistor divider.
32	EN2	I	Enable for BUCK2. Float to enable. Use this pin to adjust the UVLO input voltage of BUCK2 with a resistor divider.
—	PAD	—	No electric signal is down bonded to thermal pad inside the device. Exposed thermal pad must be soldered to PCB for optimal thermal performance.

## 6 Specifications

### 6.1 Absolute Maximum Ratings

over operating free-air temperature (unless otherwise noted)<sup>(1)</sup>

	MIN	MAX	UNIT
PVIN1, PVIN2, PVIN3, VIN	-0.3	12	V
LX1, LX2, LX3 (Maximum withstand voltage transient < 20 ns)	-1	15	V
BST1, BST2, BST3 referenced to LX1, LX2, LX3 pins respectively	-0.3	7	V
EN1, EN2, EN3, V7V, PGOOD	-0.3	7	V
FB1, FB2, FB3, COMP1, COMP2, COMP3, ROSC, SS1, SS2, SS3	-0.3	3.6	V
AGND, PGND1, PGND2, PGND3	-0.3	0.3	V
Operating junction temperature, T <sub>J</sub>	-40	150	°C
Storage temperature, T <sub>stg</sub>	-55	150	°C

(1) Stresses beyond those listed under *Absolute Maximum Ratings* may cause permanent damage to the device. These are stress ratings only, which do not imply functional operation of the device at these or any other conditions beyond those indicated under *Recommended Operating Conditions*. Exposure to absolute-maximum-rated conditions for extended periods may affect device reliability.

### 6.2 ESD Ratings

		VALUE	UNIT	
V <sub>(ESD)</sub>	Electrostatic discharge	Human-body model (HBM), per AEC Q100-002 <sup>(1)</sup>	±2000	
		Charged-device model (CDM), per AEC Q100-011	All pins	±500
			Corner pins (1, 8, 9, 16, 17, 24, 25, and 32)	±750

(1) AEC Q100-002 indicates that HBM stressing shall be in accordance with the ANSI/ESDA/JEDEC JS-001 specification.

### 6.3 Recommended Operating Conditions

over operating free-air temperature range (unless otherwise noted)

	MIN	MAX	UNIT
PVIN1, PVIN2, PVIN3, VIN	4	8	V
LX1, LX2, LX3 (Maximum withstand voltage transient <20 ns)	-0.8	10	V
BST1, BST2, BST3 referenced to LX1, LX2, LX3 pins respectively	-0.1	6.8	V
EN1, EN2, EN3, V7V, PGOOD	-0.1	6.3	V
FB1, FB2, FB3, COMP1, COMP2, COMP3, ROSC, SS1, SS2, SS3	-0.1	3	V
Operating junction temperature, T <sub>J</sub>	-40	125	°C

### 6.4 Thermal Information

THERMAL METRIC <sup>(1)</sup>		TPS65268-Q1	
		RHB (VQFN)	UNIT
		32 PINS	
R <sub>θJA</sub>	Junction-to-ambient thermal resistance	33.3	°C/W
R <sub>θJC(top)</sub>	Junction-to-case (top) thermal resistance	25.7	°C/W
R <sub>θJB</sub>	Junction-to-board thermal resistance	7.4	°C/W
ψ <sub>JT</sub>	Junction-to-top characterization parameter	0.3	°C/W
ψ <sub>JB</sub>	Junction-to-board characterization parameter	7.3	°C/W
R <sub>θJC(bot)</sub>	Junction-to-case (bottom) thermal resistance	2.1	°C/W

(1) For more information about traditional and new thermal metrics, see the [Semiconductor and IC Package Thermal Metrics application report](#).

## 6.5 Electrical Characteristics

 $V_{IN} = 5\text{ V}$ ,  $f_{SW} = 2\text{ MHz}$ ,  $-40^{\circ}\text{C} \geq T_J \geq 125^{\circ}\text{C}$ , typical values are at  $T_J = 25^{\circ}\text{C}$  (unless otherwise noted)

PARAMETER		TEST CONDITIONS	MIN	TYP	MAX	UNIT
<b>INPUT SUPPLY VOLTAGE</b>						
$V_{IN}$	Input voltage range		4		8	V
UVLO	VIN UVLO	VIN rising	3.5	3.8	4	V
		VIN falling	3.1	3.3	3.5	V
UVLO <sub>hys</sub>	VIN UVLO hysteresis			500		mV
IDD <sub>SDN</sub>	Shutdown supply current	$V_{EN1} = V_{EN2} = V_{EN3} = 0\text{ V}$	2.5	6	15	μA
IDD <sub>Q_NSW</sub>	Input quiescent current without BUCK1, BUCK2, BUCK3 switching	$V_{EN1} = V_{EN2} = V_{EN3} = 3\text{ V}$ , $V_{FB1} = V_{FB2} = V_{FB3} = 0.8\text{ V}$	550	780	1150	μA
IDD <sub>Q_NSW1</sub>		$V_{EN1} = 3\text{ V}$ , $V_{EN2} = V_{EN3} = 0\text{ V}$ , $V_{FB1} = 0.8\text{ V}$	180	370	590	
IDD <sub>Q_NSW2</sub>		$V_{EN2} = 3\text{ V}$ , $V_{EN1} = V_{EN3} = 0\text{ V}$ , $V_{FB2} = 0.8\text{ V}$	180	370	590	
IDD <sub>Q_NSW3</sub>		$V_{EN3} = 3\text{ V}$ , $V_{EN1} = V_{EN2} = 0\text{ V}$ , $V_{FB3} = 0.8\text{ V}$	180	370	590	
$V_{V7V}$	V7V LDO output voltage	$V_{IN} = 5\text{ V}$ , $V_{V7V}$ load current = 0 A		4.96		V
		$V_{IN} = 8\text{ V}$ , $V_{V7V}$ load current = 0 A		6.3		V
I <sub>OCP_V7V</sub>	V7V LDO current limit		78	185	260	mA
<b>FEEDBACK VOLTAGE REFERENCE</b>						
$V_{FB}$	Feedback voltage	$V_{COMP} = 1.2\text{ V}$	0.594	0.6	0.606	V
<b>BUCK1, BUCK2, BUCK3</b>						
$V_{ENxH}$	EN1, EN2, EN3 high-level input voltage		1.12	1.2	1.26	V
$V_{ENxL}$	EN1, EN2, EN3 low-level input voltage		1.05	1.15	1.21	V
I <sub>ENx1</sub>	EN1, EN2, EN3 pullup current	$V_{ENx} = 1\text{ V}$	2.5	3.9	5.9	μA
I <sub>ENx2</sub>		$V_{ENx} = 1.5\text{ V}$	5.1	6.9	9.2	
I <sub>ENhys</sub>	Hysteresis current		2.6	3	3.3	μA
I <sub>SSX</sub>	Soft-start charging current		3.9	5.2	6.5	μA
t <sub>ON_MIN</sub>	Minimum on-time		50	75	110	ns
G <sub>m_EA</sub>	Error amplifier transconductance	$-2\text{ μA} < I_{COMPx} < 2\text{ μA}$	140	300	450	μs
G <sub>m_PS1/2/3</sub>	COMP1/2/3 voltage to inductor current G <sub>m</sub> <sup>(1)</sup>	I <sub>LX</sub> = 0.5 A		7.4		A/V
I <sub>LIMIT1</sub>	BUCK1 peak inductor current limit		4.8	5.9	7	A
I <sub>LIMITSINK1</sub>	BUCK1 low-side sink current limit		0.7	1.3	1.8	A
I <sub>LIMIT2/3</sub>	BUCK2/BUCK3 peak inductor current limit		2.55	3.3	4	A
I <sub>LIMITSINK2/3</sub>	BUCK2/BUCK3 low-side sink current limit		0.5	1	1.4	A
R <sub>dson_HS1</sub>	BUCK1 high-side switch resistance	$V_{IN} = 5\text{ V}$		110		mΩ
R <sub>dson_LS1</sub>	BUCK1 low-side switch resistance	$V_{IN} = 5\text{ V}$		67		mΩ
R <sub>dson_HS2</sub>	BUCK2 high-side switch resistance	$V_{IN} = 5\text{ V}$		149		mΩ
R <sub>dson_LS2</sub>	BUCK2 low-side switch resistance	$V_{IN} = 5\text{ V}$		94		mΩ
R <sub>dson_HS3</sub>	BUCK3 high-side switch resistance	$V_{IN} = 5\text{ V}$		149		mΩ
R <sub>dson_LS3</sub>	BUCK3 low-side switch resistance	$V_{IN} = 5\text{ V}$		94		mΩ
<b>POWER GOOD</b>						
$V_{th\_PG}$	Feedback voltage threshold	FBx undervoltage falling		92.5		%V <sub>ref</sub>
		FBx undervoltage rising		95		
		FBx overvoltage rising		107.5		
		FBx overvoltage falling		105		
t <sub>DEGLITCH(PG)_F</sub>	PGOOD falling edge deglitch time			112		cycles
t <sub>RDEGLITCH(PG)_R</sub>	PGOOD rising edge deglitch time			616		cycles
I <sub>PG</sub>	PGOOD pin leakage				0.1	μA
V <sub>LOW_PG</sub>	PGOOD pin low voltage	I <sub>SINK</sub> = 1 mA			0.4	V
<b>OSCILLATOR</b>						
f <sub>SW</sub>	Switching frequency	R <sub>OSC</sub> = 88.7 kΩ	430	500	560	kHz
f <sub>SW_range</sub>	Switching frequency		200		2300	kHz
f <sub>SYNC_w</sub>	Clock sync minimum pulse width		80			ns

(1) Lab validation result

## Electrical Characteristics (continued)

$V_{IN} = 5\text{ V}$ ,  $f_{SW} = 2\text{ MHz}$ ,  $-40^{\circ}\text{C} \geq T_J \geq 125^{\circ}\text{C}$ , typical values are at  $T_J = 25^{\circ}\text{C}$  (unless otherwise noted)

PARAMETER		TEST CONDITIONS	MIN	TYP	MAX	UNIT
$f_{\text{SYNC\_HI}}$	Clock sync high threshold				2	V
$f_{\text{SYNC\_LO}}$	Clock sync low threshold		0.4			V
$f_{\text{SYNC}}$	Clock sync frequency range		200		2300	kHz
<b>THERMAL PROTECTION</b>						
$T_{\text{TRIP\_OTP}}$	Thermal protection trip point <sup>(1)</sup>	Temperature rising		160		$^{\circ}\text{C}$
$T_{\text{HYST\_OTP}}$	Thermal protection trip point hysteresis <sup>(1)</sup>			20		$^{\circ}\text{C}$

## 6.6 Timing Requirements

		MIN	NOM	MAX	UNIT
<b>HICCUP TIMING</b>					
$t_{\text{Hiccup\_wait}}$	Overcurrent wait time <sup>(1)</sup>		256		cycles
$t_{\text{Hiccup\_re}}$	Hiccup time before restart <sup>(1)</sup>		8192		cycles

(1) Lab validation result

### 6.7 Typical Characteristics

$T_A = 25^\circ\text{C}$ ,  $V_{IN} = 5\text{ V}$ ,  $V_{OUT1} = 1.5\text{ V}$ ,  $V_{OUT2} = 1.2\text{ V}$ ,  $V_{OUT3} = 2.5\text{ V}$ ,  $f_{SW} = 2\text{ MHz}$  (unless otherwise noted)

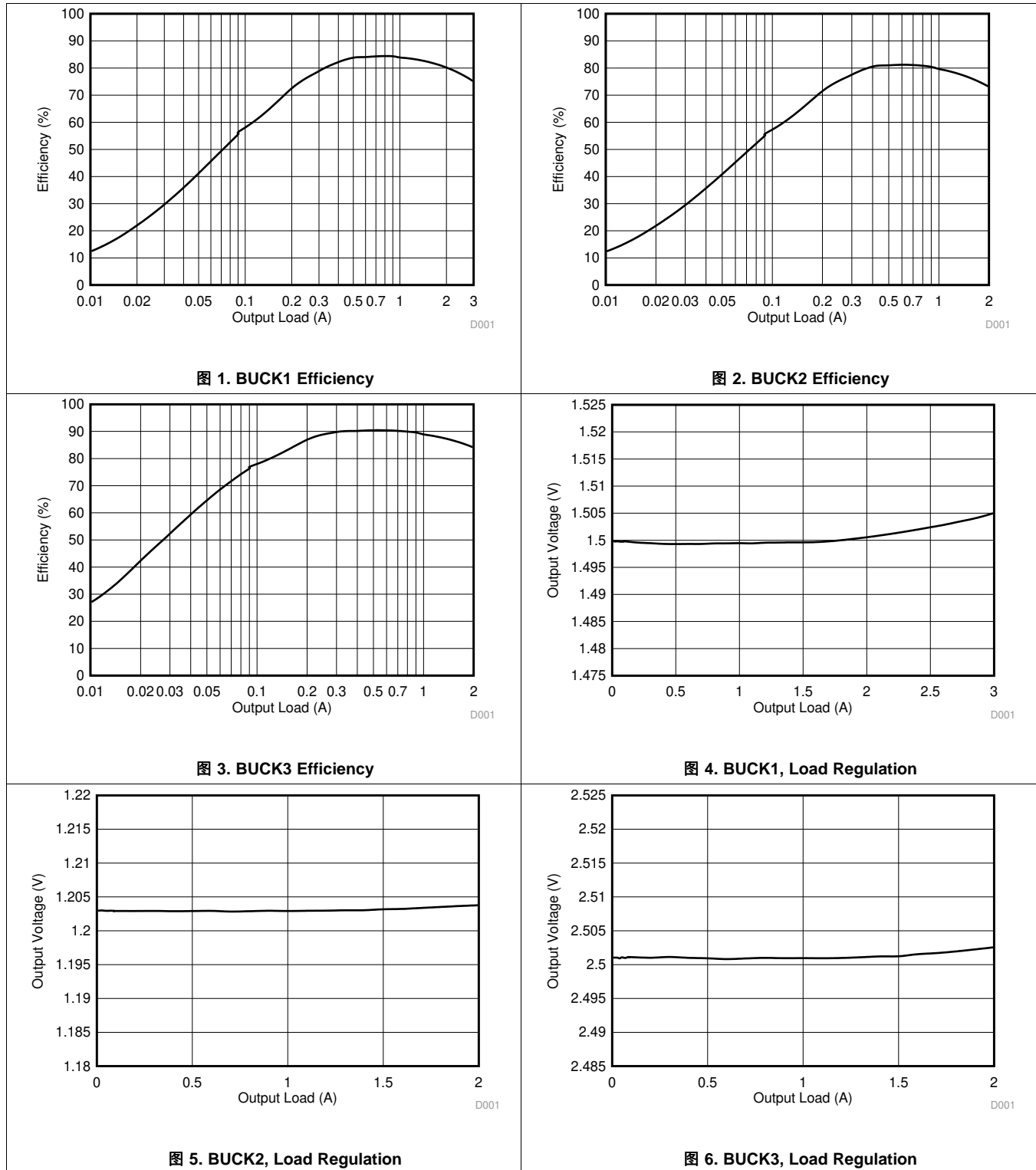

Typical Characteristics (接下页)

$T_A = 25^\circ\text{C}$ ,  $V_{IN} = 5\text{ V}$ ,  $V_{OUT1} = 1.5\text{ V}$ ,  $V_{OUT2} = 1.2\text{ V}$ ,  $V_{OUT3} = 2.5\text{ V}$ ,  $f_{SW} = 2\text{ MHz}$  (unless otherwise noted)

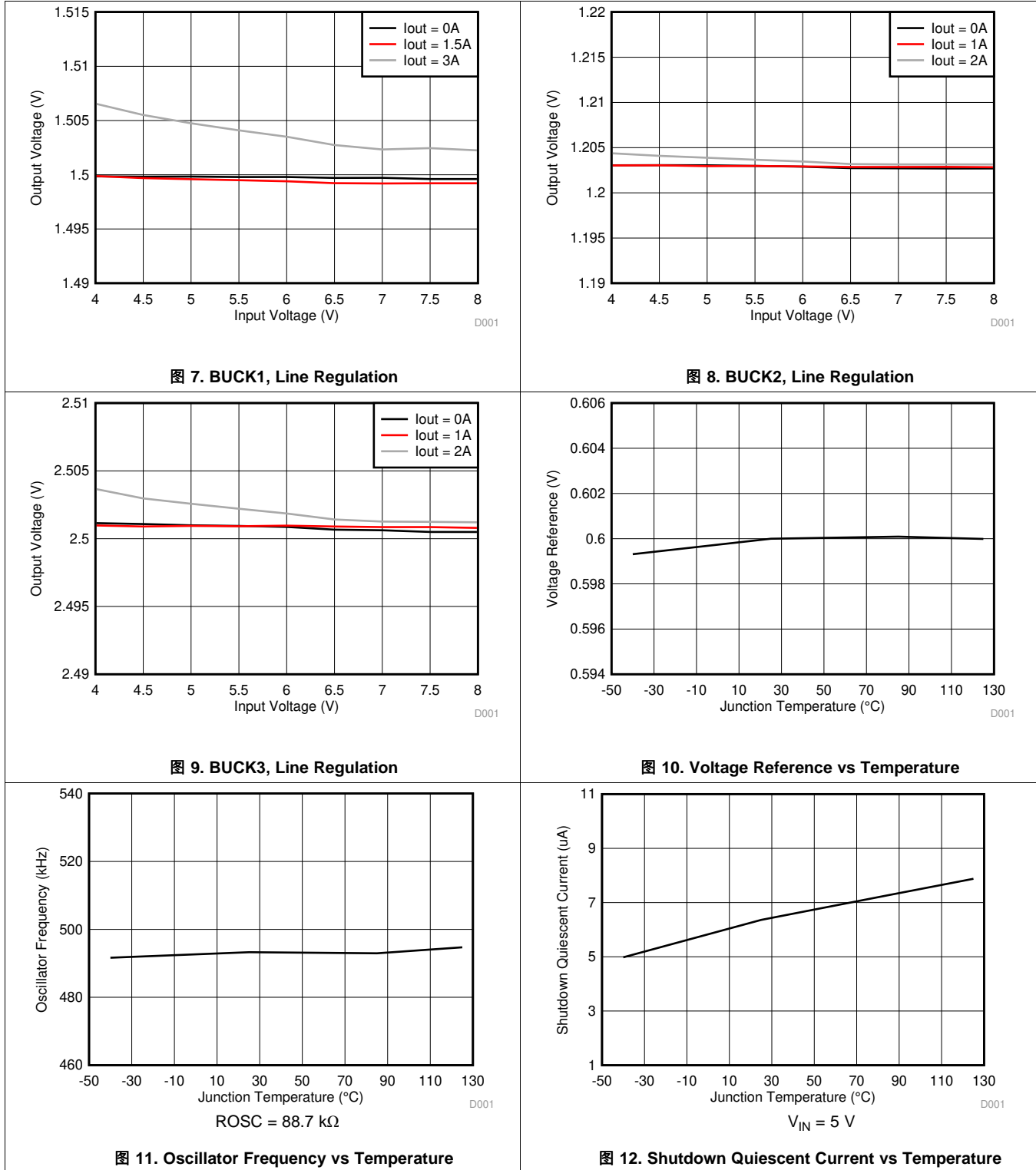

Typical Characteristics (接下页)

$T_A = 25^\circ\text{C}$ ,  $V_{IN} = 5\text{ V}$ ,  $V_{OUT1} = 1.5\text{ V}$ ,  $V_{OUT2} = 1.2\text{ V}$ ,  $V_{OUT3} = 2.5\text{ V}$ ,  $f_{SW} = 2\text{ MHz}$  (unless otherwise noted)

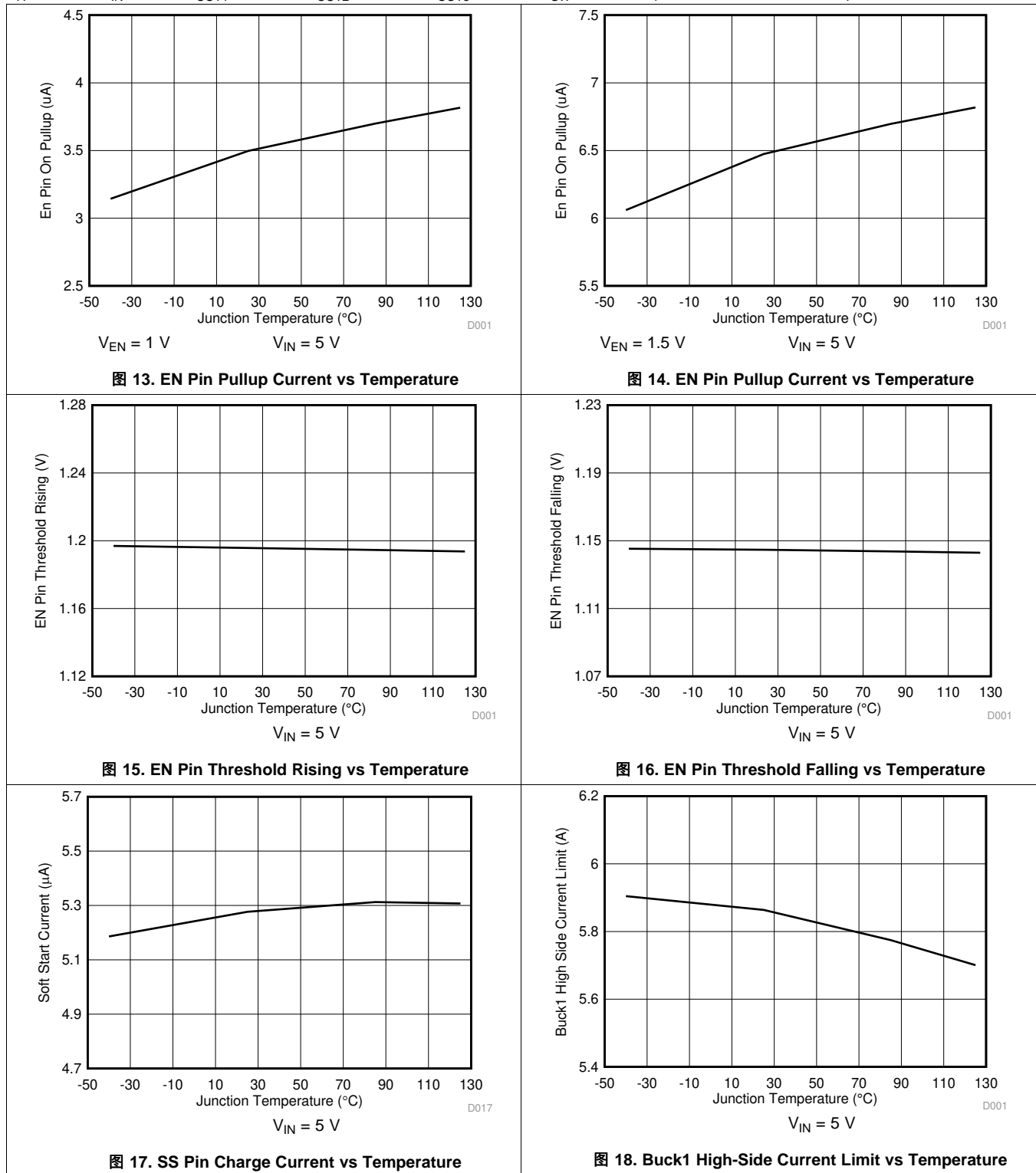

Typical Characteristics (接下页)

$T_A = 25^\circ\text{C}$ ,  $V_{IN} = 5\text{ V}$ ,  $V_{OUT1} = 1.5\text{ V}$ ,  $V_{OUT2} = 1.2\text{ V}$ ,  $V_{OUT3} = 2.5\text{ V}$ ,  $f_{SW} = 2\text{ MHz}$  (unless otherwise noted)

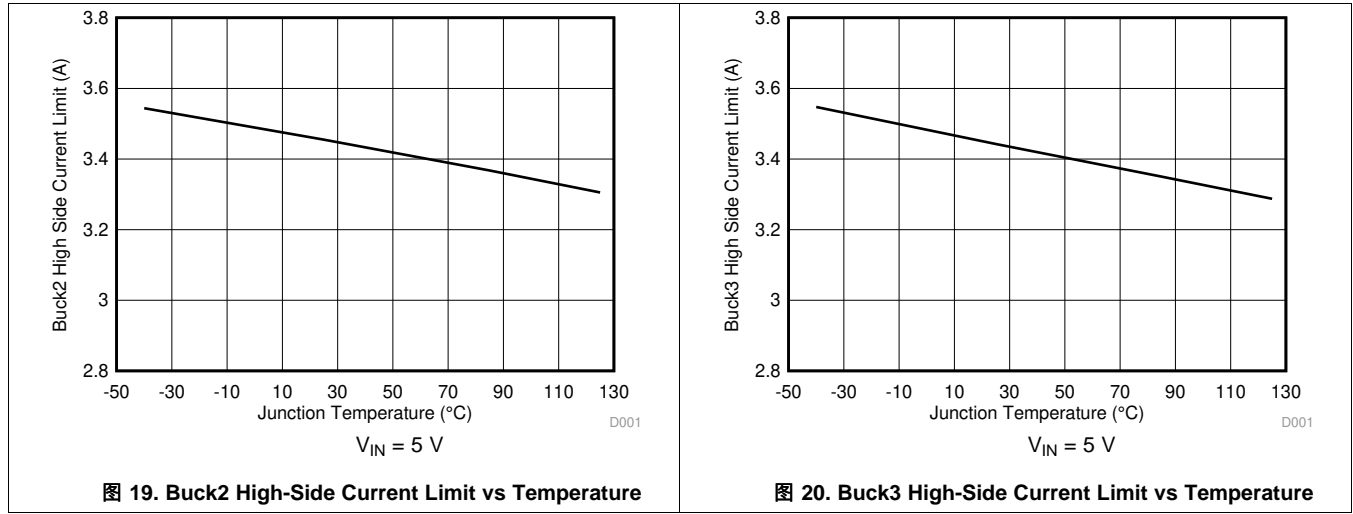

## 7 Detailed Description

### 7.1 Overview

The TPS65268-Q1 device is a monolithic triple synchronous step-down (buck) converter with 3-A, 2-A, 2-A output currents. The feedback voltage reference for each buck converter is 0.6 V. Each buck converter is independent with dedicated enable, soft-start, and loop compensation pins.

In the light load condition, the converter operates at continuous current mode (CCM) with a fixed frequency for optimized output ripple.

The TPS65268-Q1 device implements a constant-frequency, peak current-mode control that simplifies external loop compensation. The wide switching frequency of 200 kHz to 2.3 MHz allows for optimizing system efficiency, filtering size, and bandwidth. The switching frequency can be adjusted with an external resistor connecting between the ROsc pin and ground. The TPS65268-Q1 device also has an internal phase-locked loop (PLL) controlled by the ROsc pin that can be used to synchronize the switching cycle to the falling edge of an external system clock. The switching clock of BUCK1 is 180° out-of-phase operation from the clocks of BUCK2 and BUCK3 channels to reduce input current ripple, input capacitor size, and power-supply-induced noise.

The TPS65268-Q1 device is designed for safe monotonic startup into prebiased loads. The default startup is when the input voltage ( $V_{IN}$ ) is typically 3.8 V. The ENx pin can also be used to adjust the undervoltage lockout (UVLO) of the input voltage with an external resistor divider. In addition, the ENx pin has an internal 3.9- $\mu$ A current source, so the ENx pin can be left floating to automatically power up the converters.

The TPS65268-Q1 device reduces the external component count by integrating the bootstrap circuit. The bias voltage for the integrated high-side MOSFET is supplied by a capacitor between the BST and LXx pins. A UVLO circuit monitors the bootstrap capacitor voltage ( $V_{BST-V_{LX}}$ ) in each buck converter. When the  $V_{BST-V_{LX}}$  voltage drops to the threshold, the LXx pin is pulled low to recharge the bootstrap capacitor. The TPS65268-Q1 device can operate at 100% duty cycle as long as the bootstrap capacitor voltage is higher than the BOOT-LX UVLO threshold, which is typically 2.1 V.

The TPS65268-Q1 device has power-good comparators with hysteresis, which monitor the output voltages through internal feedback voltages. The device also features the PGOOD pin to supervise output voltages of the buck converter. When all buck converters are in the regulation range and power sequence is complete, the PGOOD pin is asserted high.

The soft-start and tracking pin (SSx) is used to minimize inrush currents or provide power-supply sequencing during power up. A small value capacitor or resistor divider is connected to the pin for soft-start or voltage tracking.

The TPS65268-Q1 device is protected from overload and overtemperature fault conditions. The converter minimizes excessive output overvoltage transients by taking advantage of the power-good comparator. During an output overvoltage condition, the high-side MOSFET is turned off until the internal feedback voltage is lower than 105% of the 0.6-V reference voltage. The TPS65268-Q1 device implements both high-side MOSFET overload protection and bidirectional low-side MOSFET overload protections to avoid inductor current runaway. If the overcurrent (OC) condition has lasted for more than the OC wait time (256 clock cycle), the converter shuts down and restarts after the hiccup time (8192 clock cycles). The TPS65268-Q1 device shuts down if the junction temperature is higher than thermal shutdown trip point. When the junction temperature drops 20°C typically below the thermal shutdown trip point, the TPS65268-Q1 device is restarted under control of the soft-start circuit automatically.

## 7.2 Functional Block Diagram

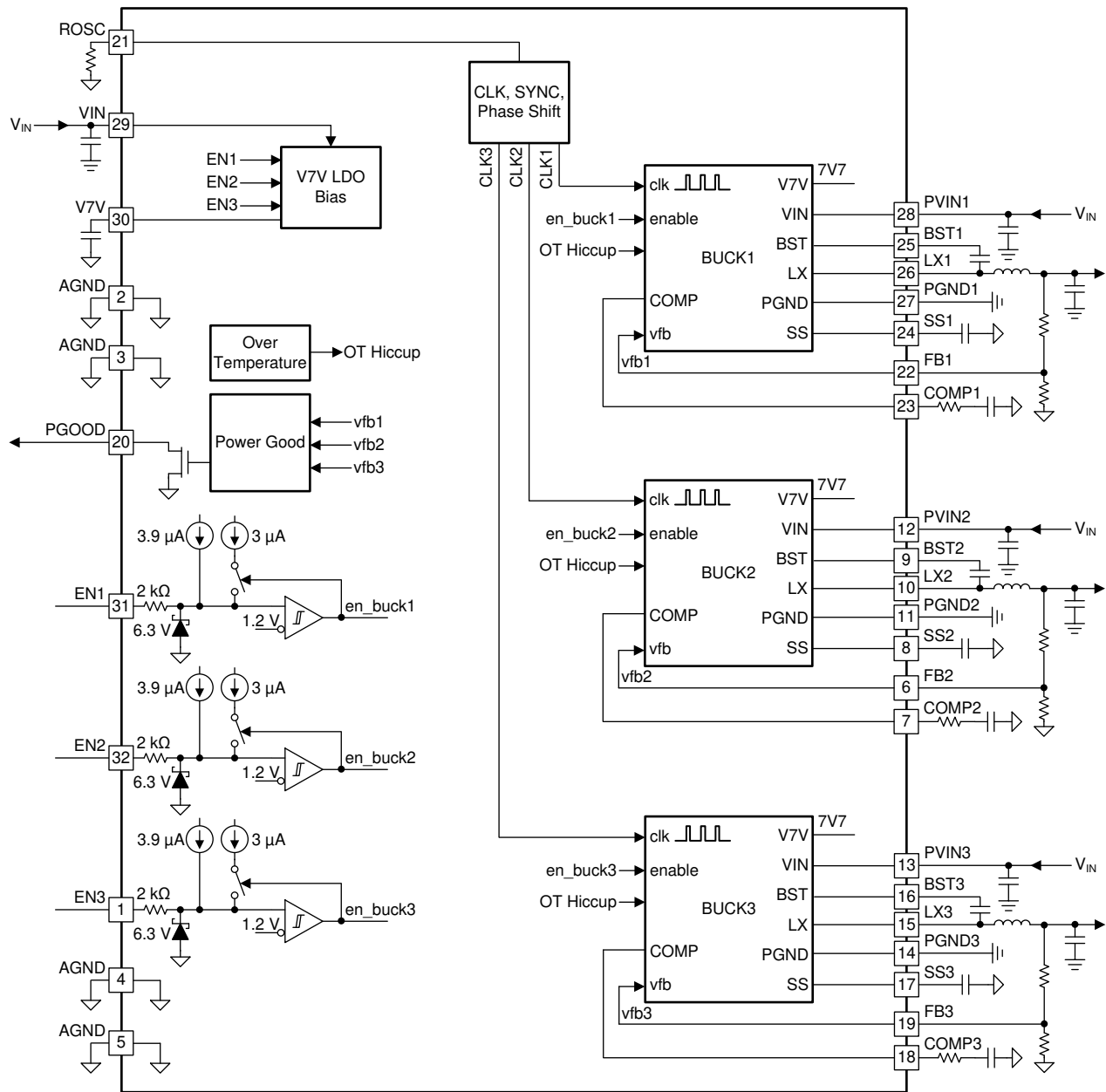

Copyright © 2017, Texas Instruments Incorporated

## 7.3 Feature Description

### 7.3.1 Adjusting the Output Voltage

The output voltage of each buck converter is set with a resistor divider from the output of the buck converter to the FB pin as shown in [Figure 21](#). TI recommends using 1% tolerance or better resistors. Use [Equation 1](#) to calculate the value of R2.

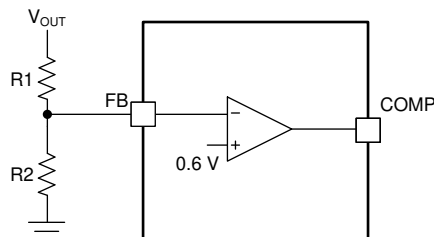
**Feature Description (接下页)**

**图 21. Voltage Divider Circuit**

$$R2 = R1 \times \frac{0.6}{V_{OUT} - 0.6} \quad (1)$$

To improve efficiency at light loads, consider using larger value resistors. If the values are too high, the regulator is more sensitive to noise. 表 1 lists the recommended resistor values.

**表 1. Output Resistor Divider Selection**

OUTPUT VOLTAGE (V)	R1 (kΩ)	R2 (kΩ)
1	10	15
1.2	10	10
1.5	15	10
1.8	20	10
2.5	31.6	10
3.3	45.3	10
3.3	22.6	4.99
5	73.2	10
5	36.5	4.99

**7.3.2 Enable and Adjusting UVLO**

The ENx pin provides electrical on and off control of the device. After the ENx pin voltage exceeds the threshold voltage, the device starts operation. If each ENx pin voltage is pulled below the threshold voltage, the regulator stops switching and enters a low quiescent-current ( $I_Q$ ) state.

The ENx pin has an internal pullup current source, allowing the user to float the ENx pin to enable the device. If an application requires controlling the ENx pin, use open-drain or open-collector output logic to interface with the pin.

The device implements internal UVLO circuitry on the VIN pin. The device is disabled when the VIN pin voltage falls below the internal UVLO threshold of the input voltage. The internal UVLO threshold of the input voltage has a hysteresis of 500 mV. If an application requires either a higher UVLO threshold on the VIN pin or a secondary UVLO on the PVINx in split-rail applications, then the user can configure the ENx pin as shown in 图 22, 图 23, and 图 24. When using the external UVLO function, TI recommends setting the hysteresis higher than 500 mV.

The ENx pin has a small pullup current,  $I_p$ , which sets the default state of the pin to enable when no external components are connected. The pullup current is also used to control the voltage hysteresis for the UVLO function because it increases by  $I_h$  after the ENx pin crosses the enable threshold. Use 公式 2 and 公式 3 to calculate the UVLO thresholds.

$$R1 = \frac{V_{START} \left( \frac{V_{ENFALLING}}{V_{ENRISING}} \right) - V_{STOP}}{I_p \left( 1 - \frac{V_{ENFALLING}}{V_{ENRISING}} \right) + I_h} \quad (2)$$

$$R2 = \frac{R1 \times V_{ENFALLING}}{V_{STOP} - V_{ENFALLING} + R1(I_h + I_p)}$$

where

- $I_h = 3 \mu A$
- $I_p = 3.9 \mu A$
- $V_{ENRISING} = 1.2 V$
- $V_{ENFALLING} = 1.15 V$

(3)



图 22. Adjustable  $V_{IN}$  UVLO



图 23. Adjustable  $PV_{IN}$  UVLO,  $V_{IN} > 4 V$

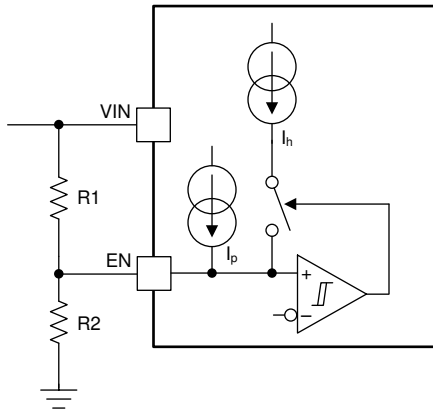

图 24. Adjustable  $V_{IN}$  and  $PV_{IN}$  UVLO

### 7.3.3 Soft-Start Time

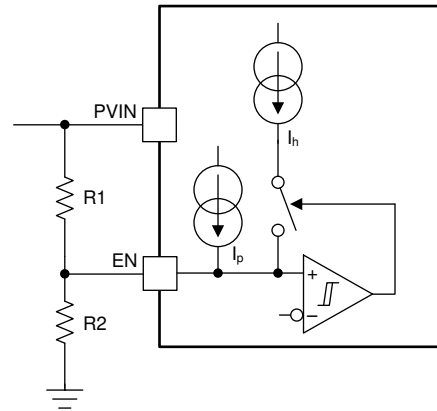
The voltage on the respective SSx pin controls the startup of buck output. When the voltage on the SSx pin is less than the internal 0.6-V reference, the TPS65268-Q1 device regulates the internal feedback voltage to the voltage on the SSx pin instead of 0.6 V. The SSx pin can be used to program an external soft-start function or to allow the output of buck converter to track another supply during start-up. The device has an internal pullup current source of 5.2  $\mu A$  (typical) that charges an external soft-start capacitor to provide a linear ramping voltage at the SSx pin. The TPS65268-Q1 device regulates the internal feedback voltage to the voltage on the SSx pin, allowing the output voltage to rise smoothly from 0 V to the regulated voltage of the pin without inrush current. Use 公式 4 to calculate the approximate soft-start time.

$$t_{SS} (ms) = \frac{C_{SS} (nF) \times V_{ref} (V)}{I_{SS} (\mu A)}$$

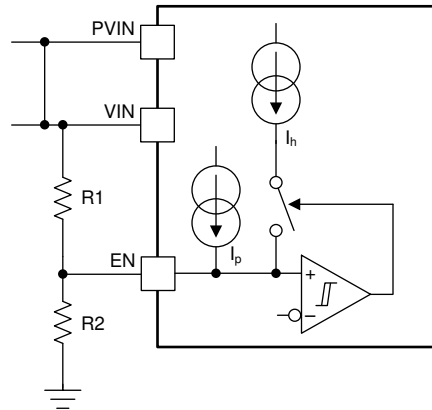
where

- $t_{SS}$  is the soft-start time

- $C_{SS}$  is the soft-start capacitance
  - $I_{SS}$  is the soft-start current
  - $V_{ref}$  is the reference voltage
- (4)

Many of the common power-supply sequencing methods can be implemented using the SSx and ENx pins. 图 25 shows the method implementing ratiometric sequencing by connecting the SSx pins of the three buck channels. The regulator outputs ramp up and reach regulation at the same time. When calculating the soft-start time, the pullup current source must be tripled in 公式 4.

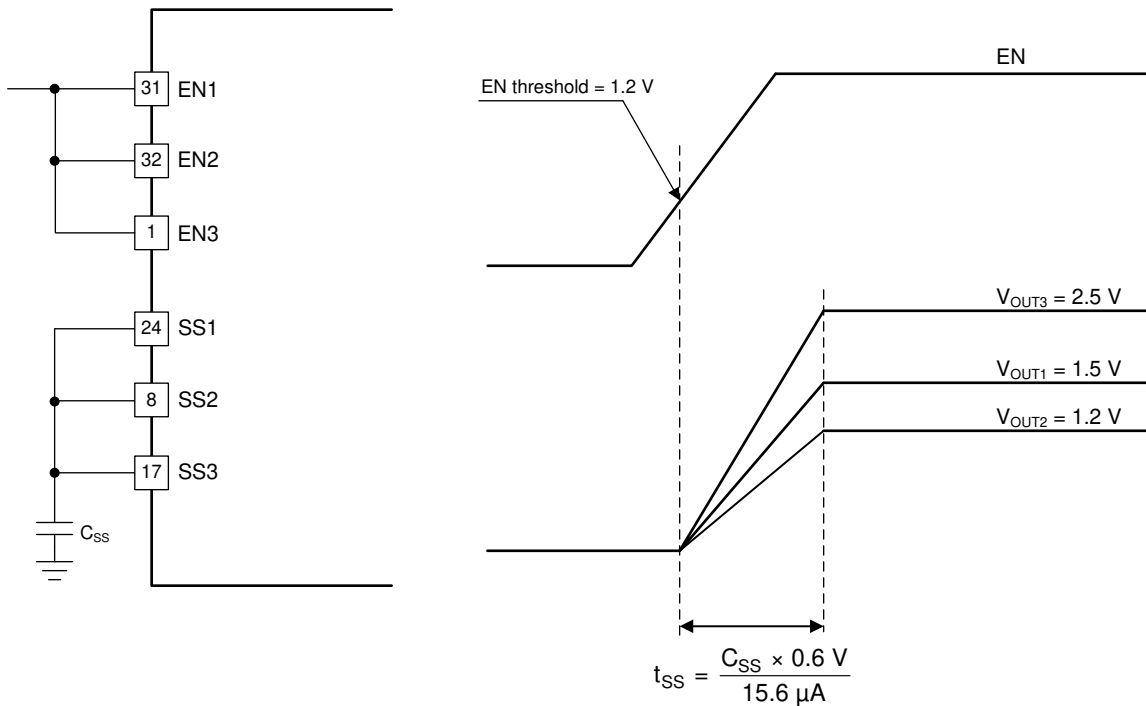

**图 25. Ratiometric Power-Up Using SSx Pins**

The user can implement simultaneous power-supply sequencing by connecting the capacitor to the SSx pin, shown in 图 26. Use 公式 4 and 公式 5 to calculate the value of the capacitors.

$$\frac{C_{SS1}}{V_{OUT1}} = \frac{C_{SS2}}{V_{OUT2}} = \frac{C_{SS3}}{V_{OUT3}} \quad (5)$$



图 26. Simultaneous Startup Sequence Using SSx Pins

### 7.3.4 Power-Up Sequencing

The TPS65268-Q1 device has a dedicated enable pin and soft-start pin for each converter. The converter enable pins are biased by a current source that allows for easy sequencing by the addition of an external capacitor. Disabling the converter with an active pulldown transistor on the ENx pin allows for predictable power-down timing operation. 图 27 shows the timing diagram of a typical buck power-up sequence with connecting a capacitor at the ENx pin.

A typical 1.4-μA current is charging the ENx pin from the input supply. When the ENx pin voltage rises to typical 0.4 V, the internal V7V LDO regulator turns on. A 3.9-μA pullup current sources the ENx pin. After the ENx pin voltage reaches the ENx enabling threshold, a 3-μA hysteresis current sources to the pin to improve noise sensitivity. The internal soft-start comparator compares the SSx pin voltage to 1.2 V. When the SSx pin voltage ramps up to 1.2 V, PGOOD monitor is enabled. After PGOOD deglitch time, PGOOD is deasserted. The SSx pin voltage is eventually clamped around 2.1 V.

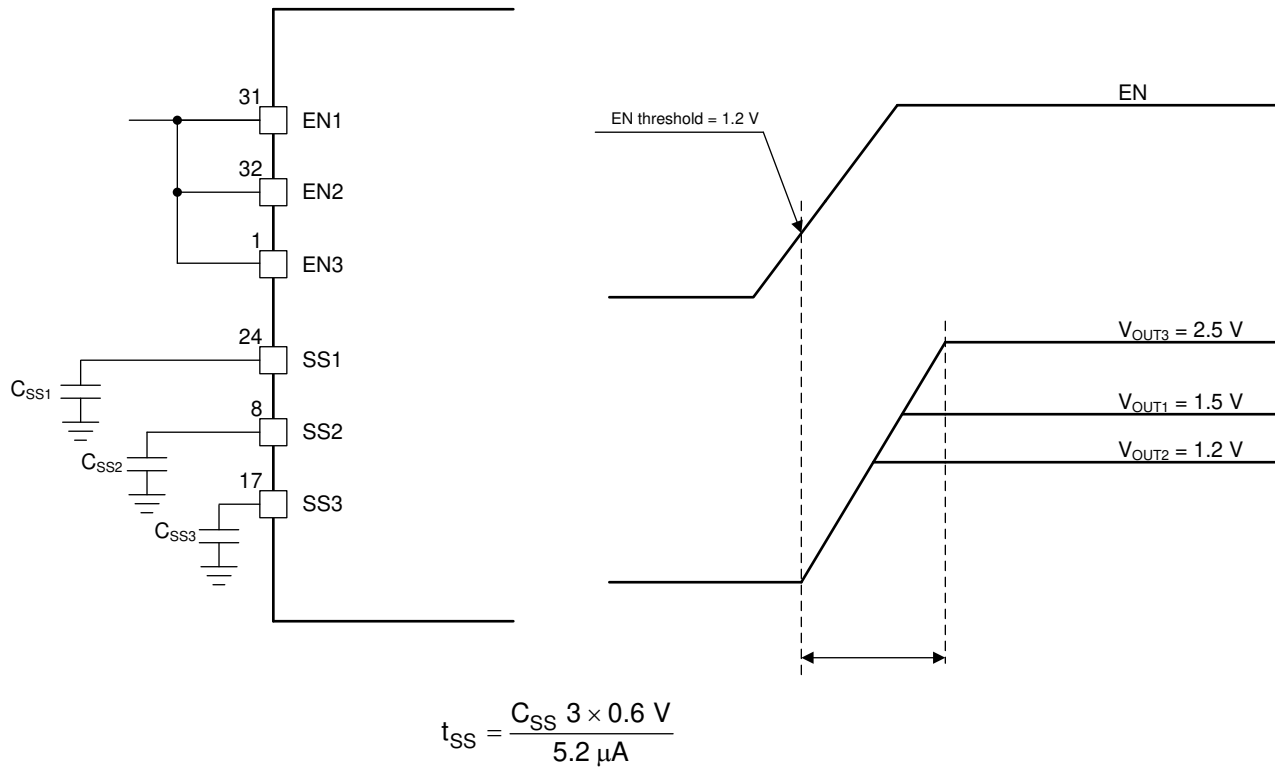
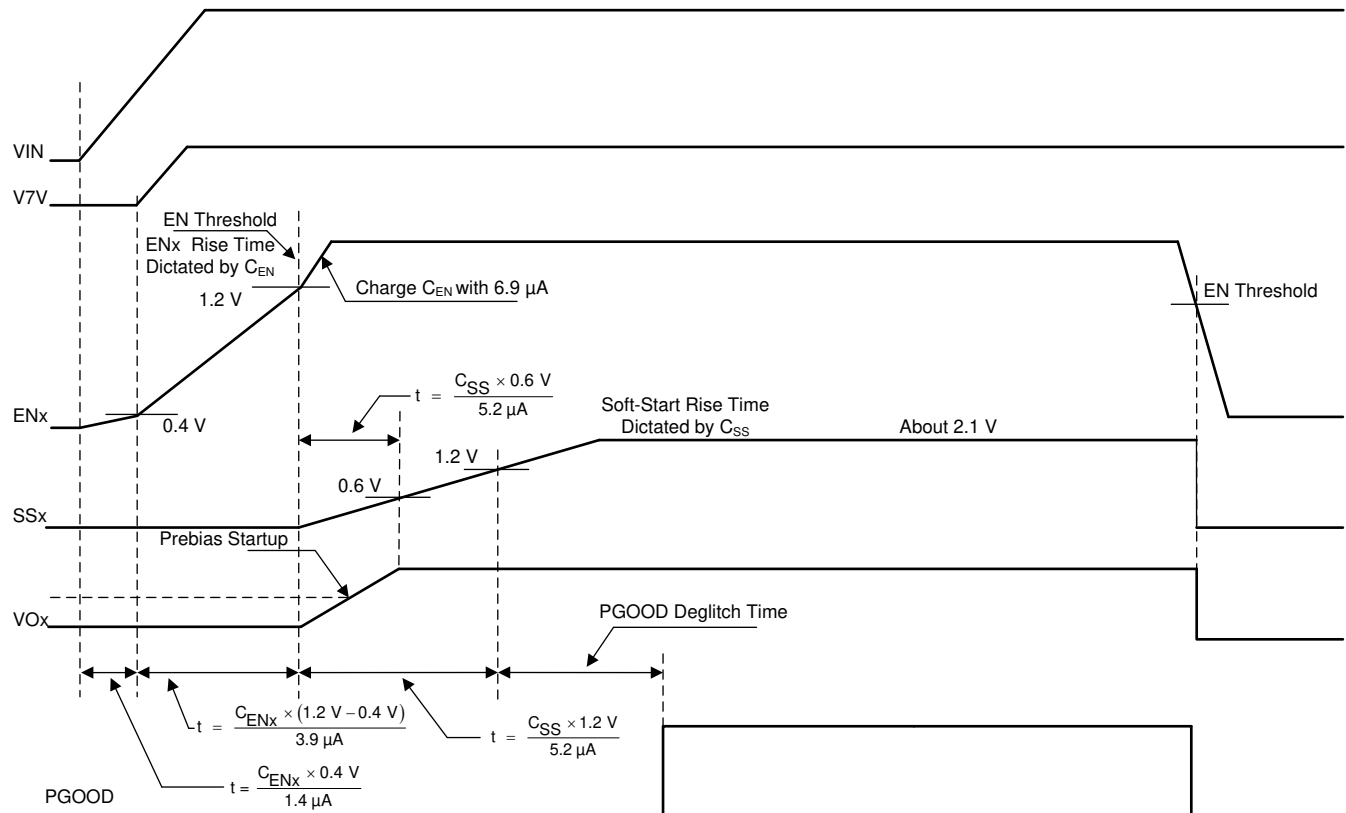
**图 27. Startup Power Sequence**

### 7.3.5 V7V Low-Dropout Regulator and Bootstrap

Power for the high-side and low-side MOSFET drivers and most other internal circuitry is derived from the V7V pin. The internal built-in low-dropout (LDO) linear regulator supplies 4.96 V (typical) from 5 V  $V_{IN}$  to the V7V voltage. The user should connect a 1- $\mu\text{F}$  ceramic capacitor from the V7V pin to power ground.

If the input voltage decreases to the UVLO threshold voltage, the UVLO comparator detects the V7V pin voltage and forces the converter off.

Each high-side MOSFET driver is biased from the floating bootstrap capacitor,  $C_B$ , shown in 图 28, which is normally recharged during each cycle through an internal low-side MOSFET or the body diode of a low-side MOSFET when the high-side MOSFET turns off. The boot capacitor is charged when the BST pin voltage is less than the input voltage and the BST-LX voltage is below regulation. TI recommends using a 47-nF ceramic capacitor. TI recommends using a ceramic capacitor with an X7R or X5R grade dielectric with a voltage rating of 10 V or higher because of the stable characteristics over temperature and voltage. Each low-side MOSFET driver is powered from the V7V pin directly.

To improve dropout, the device is designed to operate at 100% duty cycle as long as the BST to LXx pin voltage is greater than the BST-LX UVLO threshold, which is typically 2.1 V. When the voltage between the BST and LXx pins drops below the BST-LX UVLO threshold, the high-side MOSFET is turned off and the low-side MOSFET is turned on allowing the boot capacitor to be recharged.



图 28. V7V Linear Dropout Regulator and Bootstrap Voltage Diagram

### 7.3.6 Out-of-Phase Operation

To reduce the input ripple current, the switch clock of BUCK1 is 180° out-of-phase from the clock of BUCK2 and BUCK3. This operation enables the system to have less input current ripple to reduce the size, cost, and EMI of the input capacitors.

### 7.3.7 Output Overvoltage Protection (OVP)

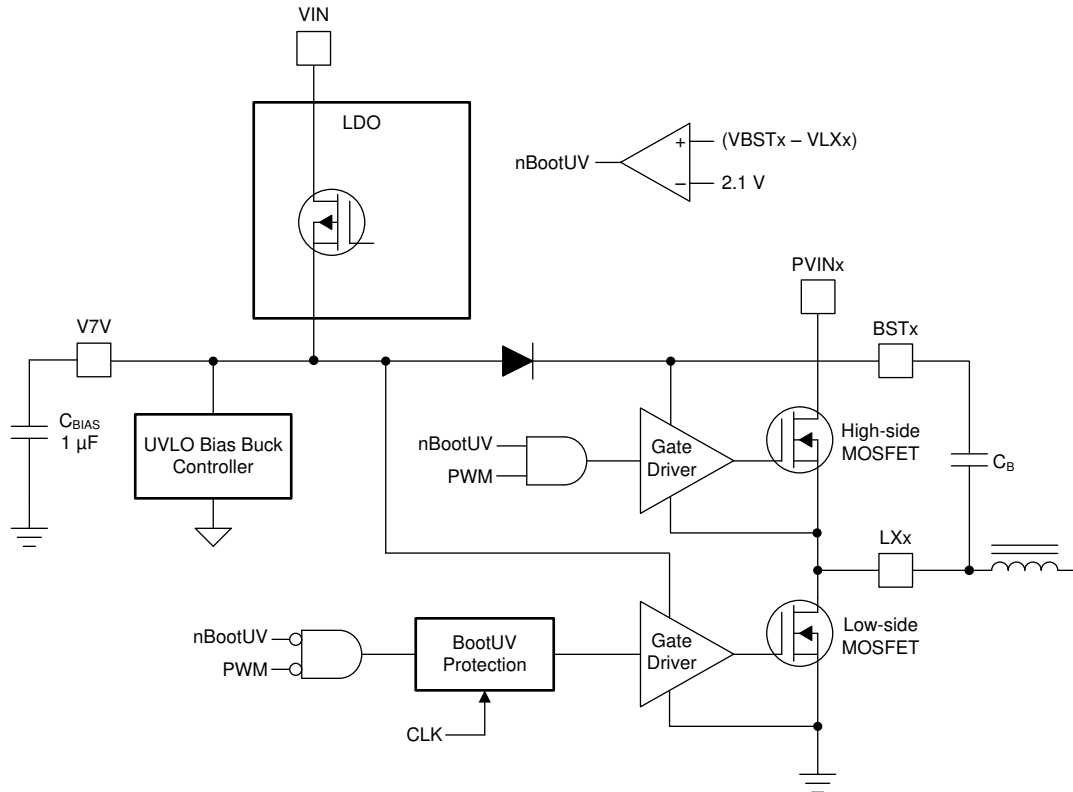
The device incorporates an OVP circuit to minimize output voltage overshoot. When the output is overloaded, the error amplifier compares the actual output voltage to the internal reference voltage. If the FB pin voltage is lower than the internal reference voltage for a considerable time, the output of the error amplifier demands maximum output current. After the condition is removed, the regulator output rises and the error amplifier output transitions to the steady-state voltage. In some applications with small output capacitance, the load can respond faster than the error amplifier which leads to the possibility of an output overshoot. Each buck converter compares the FB pin voltage to the OVP threshold. If the FB pin voltage is greater than the OVP threshold, the high-side MOSFET is turned off preventing current from flowing to the output and minimizing output overshoot. When the FB voltage drops lower than the OVP threshold, the high-side MOSFET turns on at the next clock cycle.

### 7.3.8 Slope Compensation

To prevent the subharmonic oscillations when the device operates at duty cycles greater than 50%, the TPS65268-Q1 devices adds built-in slope compensation, which is a compensating ramp to the switch current signal.

### 7.3.9 Overcurrent Protection

The device is protected from overcurrent conditions by cycle-by-cycle current limiting on both the high-side MOSFET and low-side MOSFET.

### 7.3.9.1 High-Side MOSFET Overcurrent Protection

The device implements current mode control that uses the COMP pin voltage to control the turnoff of the high-side MOSFET and the turnon of the low-side MOSFET on a cycle-by-cycle basis. During each cycle, the switch current and the current reference generated by the COMP pin voltage are compared and, when the peak switch current intersects the current reference, the high-side switch is turned off.

### 7.3.9.2 Low-Side MOSFET Overcurrent Protection

While the low-side MOSFET is turned on, its conduction current is monitored by the internal circuitry. During normal operation, the low-side MOSFET sources current to the load. At the end of every clock cycle, the low-side MOSFET sourcing current is compared to the internally set low-side sourcing current limit. If the low-side sourcing current is exceeded, the high-side MOSFET is not turned on and the low-side MOSFET stays on for the next cycle. The high-side MOSFET is turned on again when the low-side current is below the low-side sourcing current limit at the start of a cycle.

The low-side MOSFET can also sink current from the load. If the low-side sinking current limit is exceeded, the low-side MOSFET is turned off immediately for the rest of that clock cycle. In this scenario both MOSFETs are off until the start of the next cycle.

Furthermore, if an output overload condition (as measured by the COMP pin voltage) has lasted for more than the hiccup wait time which is programmed for 256 switching cycles shown in [图 29](#), the device shuts down and restarts after the hiccup time of 8192 cycles. The hiccup mode helps to reduce the device power dissipation under severe overcurrent condition.

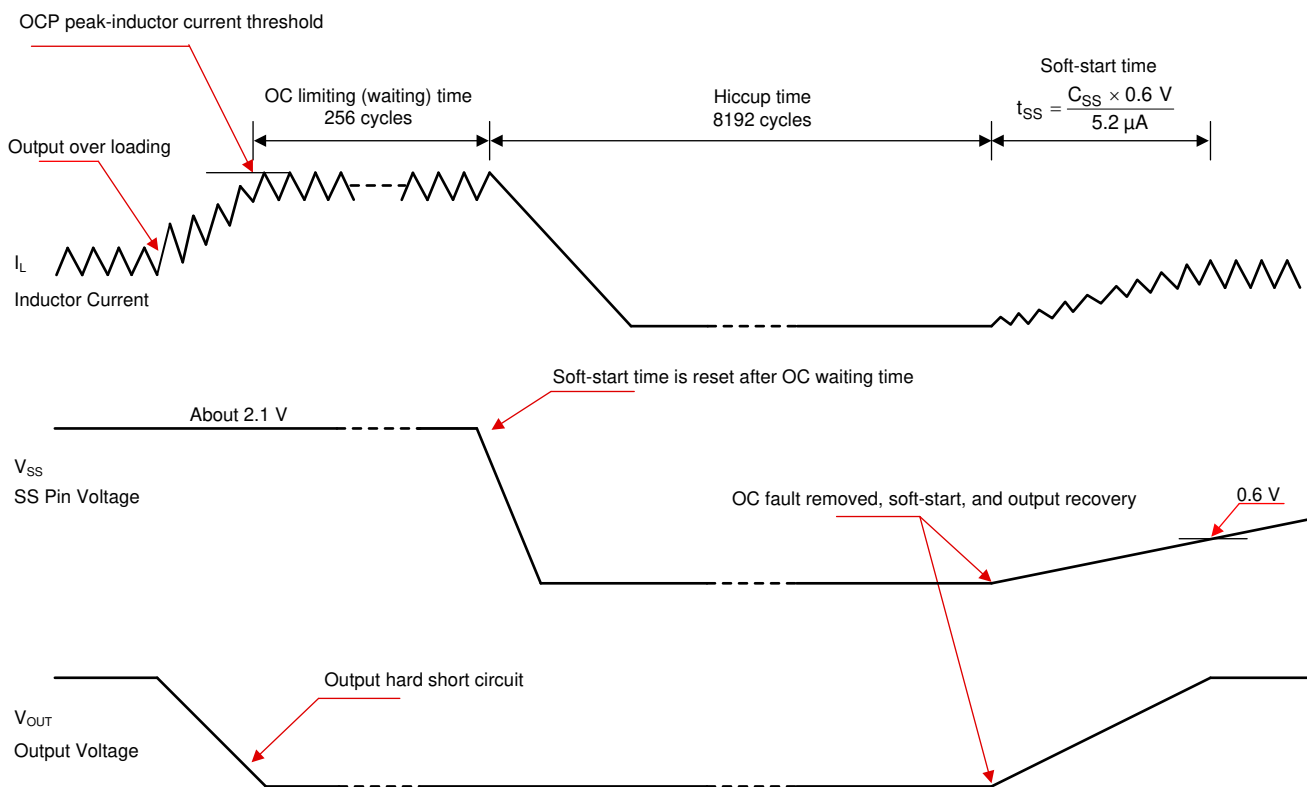

**图 29. Overcurrent Protection**

### 7.3.10 Power Good

The PGOOD pin is an open-drain output. When the feedback voltage of each buck converter is between 95% (rising) and 105% (falling) of the internal voltage reference, the PGOOD pin pulldown is deasserted and the pin floats. TI recommends using a pullup resistor with a value of 10 kΩ to 100 kΩ connected to a voltage source that is 5.5 V or less. The PGOOD pin is in a defined state when the VIN input voltage is greater than 1 V, but with reduced current sinking capability. The PGOOD pin achieves full current sinking capability after the VIN input voltage is above UVLO threshold, which is 3.8 V.

The PGOOD pin is pulled low when any feedback voltage of buck converter is lower than 92.5% (falling) or greater than 107.5% (rising) of the nominal internal reference voltage. Also, when the PGOOD pin is pulled low and during an UVLO condition on the input voltage, thermal shutdown is asserted, the ENx pin is pulled low, or the converter is in soft-start period.

### 7.3.10.1 Adjustable Switching Frequency

The ROSC pin can be used to set the switching frequency by connecting a resistor to ground. The switching frequency of the device is adjustable from 200 kHz to 2.3 MHz.

To determine the ROSC resistance for a given switching frequency, use 公式 6 or the curve in 图 30. To reduce the solution size, the user should set the switching frequency as high as possible, but consider tradeoffs of the supply efficiency and minimum controllable on-time.

$$f_{\text{OSC}} \text{ (kHz)} = 37254 \times R^{-0.966} \text{ (k}\Omega\text{)} \quad (6)$$



图 30. ROSC vs Switching Frequency

When an external clock applies to ROSC pin, the internal PLL has been implemented to allow internal clock synchronizing to an external clock from 200 kHz to 2300 kHz. To implement the clock synchronization feature, connect a square-wave clock signal to the ROSC pin with a duty cycle from 20% to 80%. The clock signal amplitude must transition lower than 0.4 V and higher than 2.0 V. The start of the switching cycle is synchronized to the falling edge of ROSC pin.

In applications where both resistor mode and synchronization mode are needed, the user can configure the device as shown in 图 31. Before an external clock is present, the device works in resistor mode and the ROSC resistor sets the switching frequency. When an external clock is present, the synchronization mode overrides the resistor mode. The first time the ROSC pin is pulled above the ROSC high threshold (2 V), the device switches from the resistor mode to the synchronization mode and the ROSC pin is in the high impedance state as the PLL starts to lock onto the frequency of the external clock. TI does not recommend switching from the synchronization mode back to the resistor mode because the internal switching frequency drops to 100 kHz first before returning to the switching frequency set by ROSC resistor.

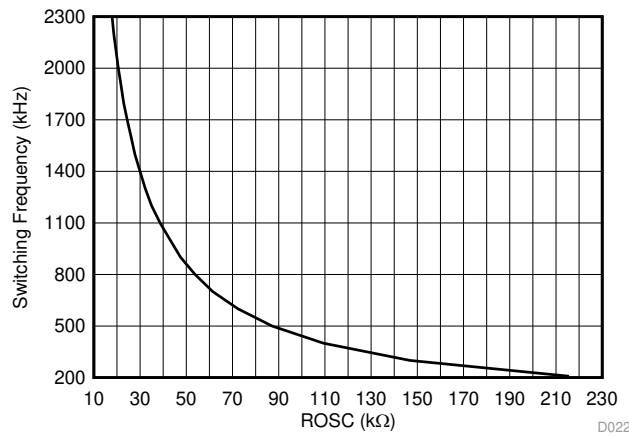

图 31. Works With Resistor Mode and Synchronization Mode

### 7.3.11 Thermal Shutdown

The internal thermal shutdown circuitry forces the device to stop switching if the junction temperature exceeds 160°C (typical). The device reinitiates the power-up sequence when the junction temperature drops below 140°C (typical).

## 7.4 Device Functional Modes

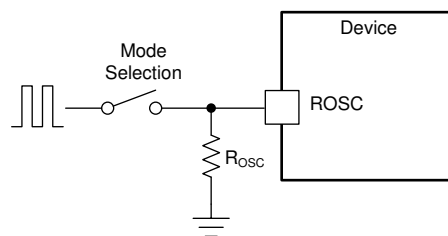
### 7.4.1 Normal Operation

When the input voltage is above the UVLO threshold and the ENx voltage is above the enable threshold, the TPS65268-Q1 device operates at continuous current mode (CCM) with a fixed frequency for optimized output ripple.

### 7.4.2 Standby Operation

When the TPS65268-Q1 device operates in normal CCM, the device can be placed in standby by pulling the ENx pin low.

## 8 Application and Implementation

### 注

Information in the following applications sections is not part of the TI component specification, and TI does not warrant its accuracy or completeness. TI's customers are responsible for determining suitability of components for their purposes. Customers should validate and test their design implementation to confirm system functionality.

### 8.1 Application Information

The device is a triple-synchronous step-down DC-DC converter. The device is typically used to convert a higher DC voltage to lower DC voltages with continuous available output current of 3 A, 2 A, 2 A.

### 8.2 Typical Application

The following design procedure can be used to select component values for the TPS65268-Q1. This section presents a simplified discussion of the design process.

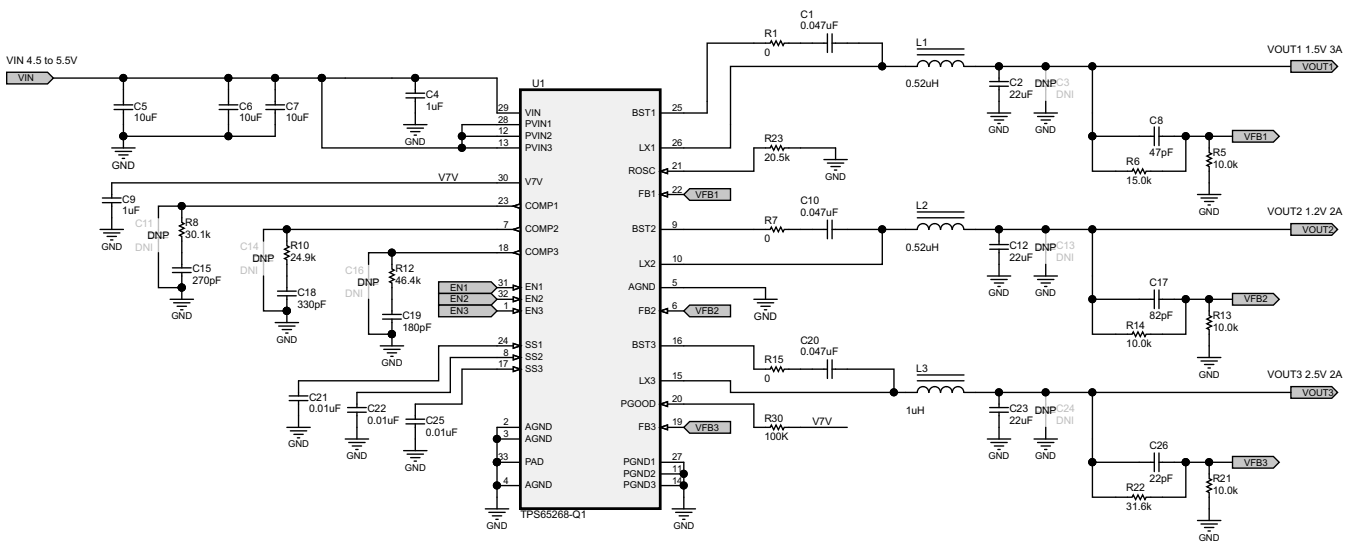

Copyright © 2016, Texas Instruments Incorporated

图 32. Typical Application Schematic

#### 8.2.1 Design Requirements

This example details the design of triple-synchronous step-down converter. A few parameters must be known to start the design process. These parameters are typically determined at the system level. For this example, start with the known parameters listed in 表 2.

表 2. Design Parameters

PARAMETER	VALUE
$V_{OUT1}$	1.5 V
$I_{OUT1}$	3 A
$V_{OUT2}$	1.2 V
$I_{OUT2}$	2 A
$V_{OUT3}$	2.5 V
$I_{OUT3}$	2 A
Transient response 1-A load step	±5%
Input voltage	5 V normal, 4.5 to 5.5V
Output voltage ripple	±1%

**表 2. Design Parameters (接下页)**

PARAMETER	VALUE
Switching frequency	2 MHz

## 8.2.2 Detailed Design Procedure

### 8.2.2.1 Output Inductor Selection

Use 公式 7 to calculate the value of the output inductor. LIR is a coefficient that represents the amount of inductor ripple current relative to the maximum output current. The inductor ripple current is filtered by the output capacitor. Therefore, choosing high inductor-ripple currents impacts the selection of the output capacitor because the output capacitor must have a ripple current rating equal to or greater than the inductor ripple current. In general, the inductor ripple value is at the discretion of the designer; however, LIR is normally from 0.1 to 0.3 for the majority of applications. Use 公式 7 to calculate the value of the inductor.

$$L = \frac{V_{INmax} - V_{OUT}}{I_{OUT} \times LIR} \times \frac{V_{OUT}}{V_{INmax} \times f_{SW}} \quad (7)$$

For the output filter inductor, the RMS current and saturation current ratings must not be exceeded. Use 公式 8 and to calculate RMS inductor current ( $I_{Lrms}$ ) and peak inductor current ( $I_{Lpeak}$ ).

$$I_{Lrms} = \sqrt{I_{OUT}^2 + \frac{\left(\frac{V_{OUT} \times (V_{INmax} - V_{OUT})}{V_{INmax} \times L \times f_{SW}}\right)^2}{12}} \quad (8)$$

$$I_{Lpeak} = I_{OUT} + \frac{I_{ripple}}{2}$$

where

$$I_{ripple} = \frac{V_{INmax} - V_{OUT}}{L} \times \frac{V_{OUT}}{V_{INmax} \times f_{SW}}$$

The current flowing through the inductor is the inductor ripple current plus the output current. During power up, faults, or transient load conditions, the inductor current can increase above the peak inductor current level calculated in 公式 9. In transient conditions, the inductor current can increase up to the switch current limit of the device. For this reason, the most conservative approach is to specify an inductor with a saturation current rating equal to or greater than the switch current limit rather than the peak inductor current.

### 8.2.2.2 Output Capacitor Selection

The three primary considerations for selecting the value of the output capacitor are:

- Output capacitor which determines the modulator pole
- Output voltage ripple
- How the regulator responds to a large change in load current

The output capacitance must be selected based on the most stringent of these three criteria.

The desired response to a large change in the load current is the first criterion. The output capacitor must supply the load with current when the regulator cannot. This situation would occur if the desired hold-up times for the regulator occur where the output capacitor must hold the output voltage above a certain level for a specified amount of time after the input power is removed. The regulator is also temporarily not able to supply sufficient output current if the current requirements of the load experience a large, fast increase, such as a transition from no load to full load. The regulator typically requires two or more clock cycles for the control loop to experience a change in load current and output voltage, and to adjust the duty cycle to react to the change. The output capacitor must be sized to supply the extra current to the load until the control loop responds to the load change. The output capacitance must be large enough to supply the difference in current for two clock cycles while only allowing a tolerable amount of droop in the output voltage. Use 公式 10 to calculate the minimum output capacitance ( $C_O$ ) required to accomplish this.

$$C_{OUT} = \frac{2 \times \Delta I_{OUT}}{f_{SW} \times \Delta V_{OUT}}$$

where

- $\Delta I_{OUT}$  is the change in output current
  - $f_{sw}$  is the regulators switching frequency
  - $\Delta V_{OUT}$  is the allowable change in the output voltage
- (10)

公式 11 calculates the minimum output capacitance required to meet the output voltage ripple specification.

$$C_{OUT} > \frac{1}{8 \times f_{SW}} \times \frac{1}{\frac{V_{OUTripple}}{I_{OUTripple}}}$$

where

- $f_{sw}$  is the switching frequency
  - $V_{OUTripple}$  is the maximum allowable output voltage ripple
  - $I_{OUTripple}$  is the inductor ripple current
- (11)

Use 公式 12 to calculate the maximum ESR an output capacitor can have to meet the output voltage ripple specification.

$$R_{esr} < \frac{V_{OUTripple}}{I_{OUTripple}}$$
(12)

Additional capacitance deratings for aging, temperature, and DC bias should be factored in, which increase this minimum value. Capacitors generally have limits to the amount of ripple current they can support without failing or producing excess heat. The user must specify an output capacitor that can support the inductor ripple current. Some capacitor data sheets specify the root mean square (RMS) value of the maximum ripple current. Use 公式 13 to calculate the RMS ripple current that the output capacitor must support ( $I_{COUTrms}$ ).

$$I_{COUTrms} = \frac{V_{OUT} \times (V_{INmax} - V_{OUT})}{\sqrt{12} \times V_{INmax} \times L \times f_{SW}}$$
(13)

### 8.2.2.3 Input Capacitor Selection

The TPS65268-Q1 device requires a high-quality ceramic, type X5R or X7R, input decoupling capacitor with at least 10  $\mu F$  of effective capacitance on the PVIN input voltage pins. In some applications, additional bulk capacitance may also be required for the PVIN input. The effective capacitance includes any DC bias effects. The voltage rating of the input capacitor must be greater than the maximum input voltage. The capacitor must also have a ripple current rating greater than the maximum input current ripple of the TPS65268-Q1. Use 公式 14 to calculate the input ripple current ( $I_{INrms}$ ).

$$I_{INrms} = I_{OUT} \times \sqrt{\frac{V_{OUT}}{V_{INmin}} \times \frac{(V_{INmin} - V_{OUT})}{V_{INmin}}}$$
(14)

The value of a ceramic capacitor varies significantly over temperature and the amount of DC bias applied to the capacitor. The capacitance variations because of temperature can be minimized by selecting a dielectric material that is stable over temperature. Ceramic dielectric capacitors with type X5R and X7R are usually selected for power regulator capacitors because they have a high capacitance-to-volume ratio and are fairly stable over temperature. The DC bias must also be considered when selecting an output capacitor. The capacitance value of a capacitor decreases as the DC bias across a capacitor increases. The input capacitance value determines the input ripple voltage of the regulator. Use 公式 15 to calculate the input voltage ripple ( $\Delta V_{IN}$ ).

$$\Delta V_{IN} = \frac{I_{OUTmax} \times 0.25}{C_{IN} \times f_{SW}}$$
(15)

### 8.2.2.4 Loop Compensation

The TPS65268-Q1 device incorporates a peak current-mode control scheme. The error amplifier is a transconductance amplifier with a gain of 300  $\mu S$ . A typical type II compensation circuit adequately delivers a phase margin from 40° to 90°. The  $C_b$  capacitor adds a high-frequency pole to attenuate high-frequency noise when needed. To calculate the external compensation components, follow these steps:

1. Select a switching frequency,  $f_{SW}$ , that is appropriate for the application depending on the inductor size,

capacitor size, output ripple, EMI, and so forth. Selecting the switching frequency is a trade-off between performance and cost. To achieve a smaller size and lower cost, a higher switching frequency is desired. To optimize efficiency, a lower switching frequency is desired.

2. Set up the crossover frequency,  $f_C$ , which is typically from 1/5 to 1/20 of  $f_{SW}$ .
3. Use 公式 16 to calculate the value of  $R_C$ .

$$R_C = \frac{2\pi \times f_C \times V_{OUT} \times C_{OUT}}{G_{m\_EA} \times V_{ref} \times G_{M\_PS}}$$

where

- $G_{m\_EA}$  is the error amplifier gain (300  $\mu$ S).
- $G_{m\_PS}$  is the power stage voltage to current conversion gain (7.4 A/V). (16)

4. Use 公式 17 to calculate the value  $C_c$  by placing a compensation zero at or before the dominant pole (

$$f_p = \frac{1}{C_{OUT} \times R_L \times 2\pi}$$

$$C_c = \frac{R_L \times C_{OUT}}{R_C} \tag{17}$$

5. Optional: Use 公式 18 to calculate the value of  $C_b$  capacitor to cancel the zero from the ESR associated with  $C_o$ .

$$C_b = \frac{R_{esr} \times C_{OUT}}{R_C} \tag{18}$$

6. Optional: Implement type III compensation with the addition of one capacitor,  $C_1$ . This implementation allows for slightly higher loop bandwidths and higher phase margins. If used, used 公式 19 to calculate the value of  $C_1$ .

$$C_1 = \frac{1}{2\pi \times R_1 \times f_C} \tag{19}$$



图 33. DC-DC Loop Compensation

### 8.2.3 Application Curves

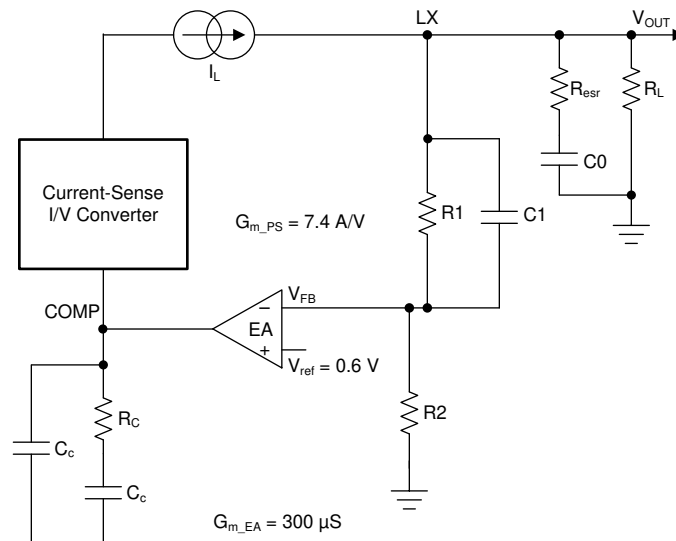
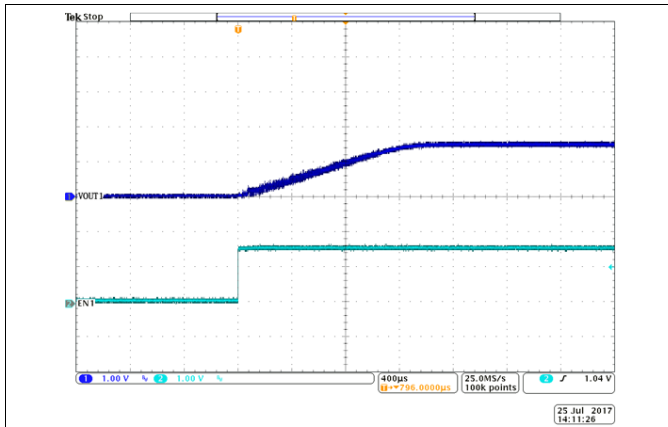

$I_{OUT} = 3\text{ A}$

图 34. BUCK1 Soft-Start

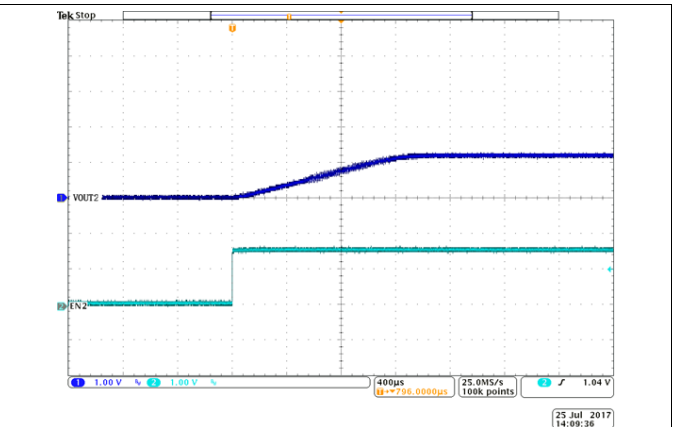

$I_{OUT} = 2\text{ A}$

图 35. BUCK2 Soft-Start

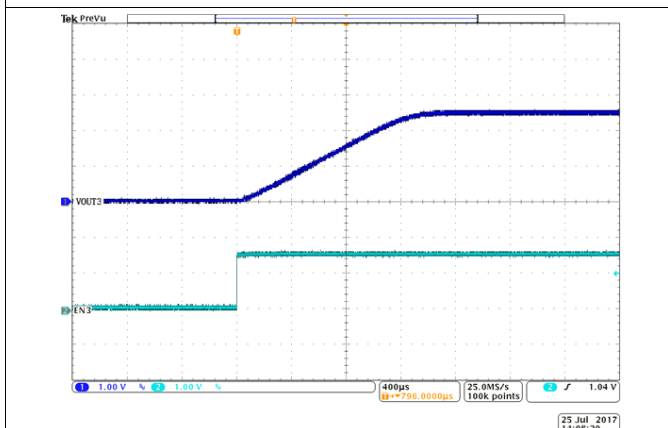

$I_{OUT} = 2\text{ A}$

图 36. BUCK3 Soft-Start

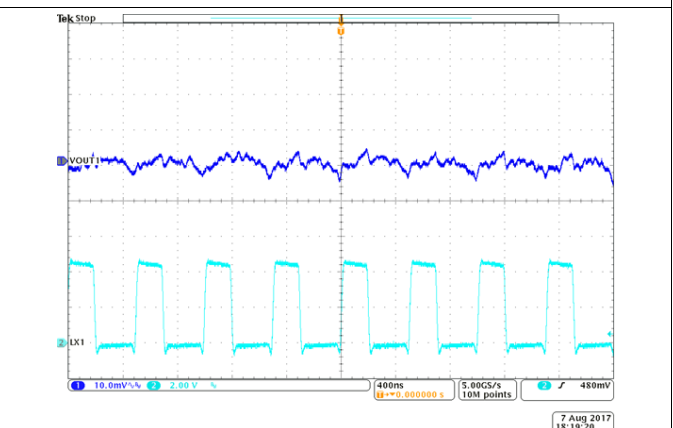

$I_{OUT} = 3\text{ A}$

图 37. BUCK1 Output Voltage Ripple

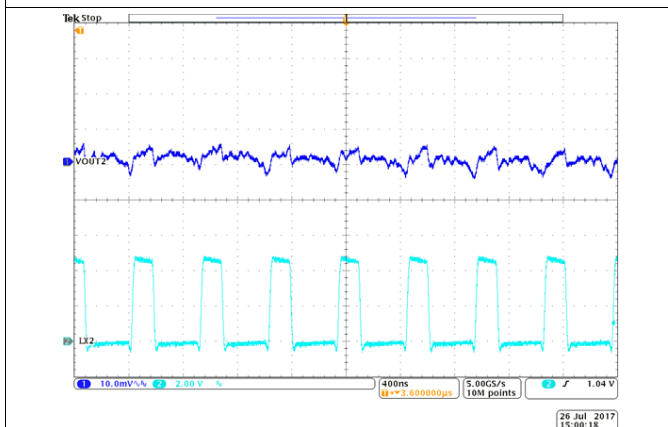

$I_{OUT} = 2\text{ A}$

图 38. BUCK2 Output Voltage Ripple

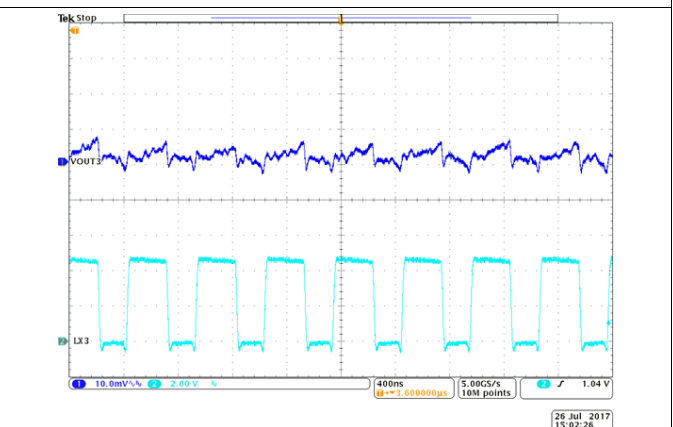

$I_{OUT} = 2\text{ A}$

图 39. BUCK3 Output Voltage Ripple

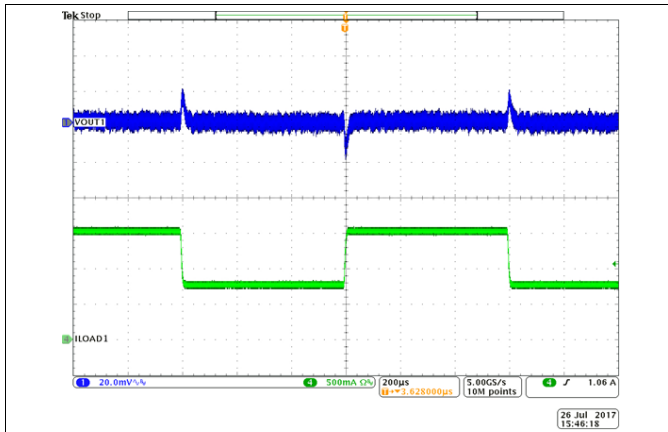

$I_{OUT} = 0.75$  to  $1.5$  A       $SR = 0.25$  A/ $\mu$ s

图 40. BUCK1 Load Transient

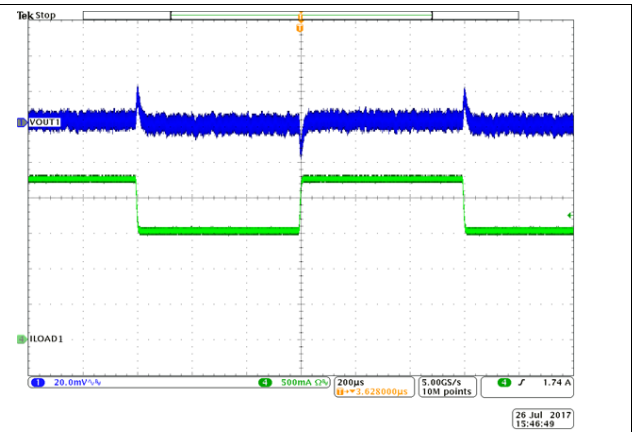

$I_{OUT} = 1.5$  to  $2.25$  A       $SR = 0.25$  A/ $\mu$ s

图 41. BUCK1 Load Transient

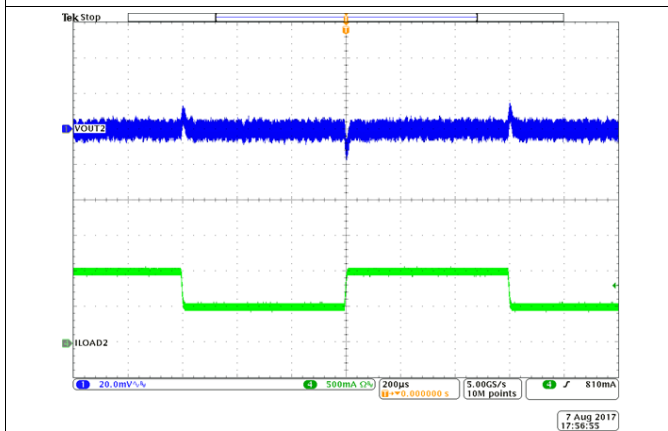

$I_{OUT} = 0.5$  to  $1$  A       $SR = 0.25$  A/ $\mu$ s

图 42. BUCK2 Load Transient

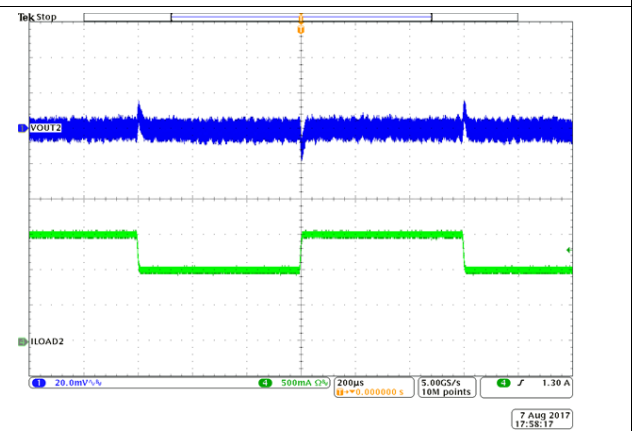

$I_{OUT} = 1$  to  $1.5$  A       $SR = 0.25$  A/ $\mu$ s

图 43. BUCK2 Load Transient

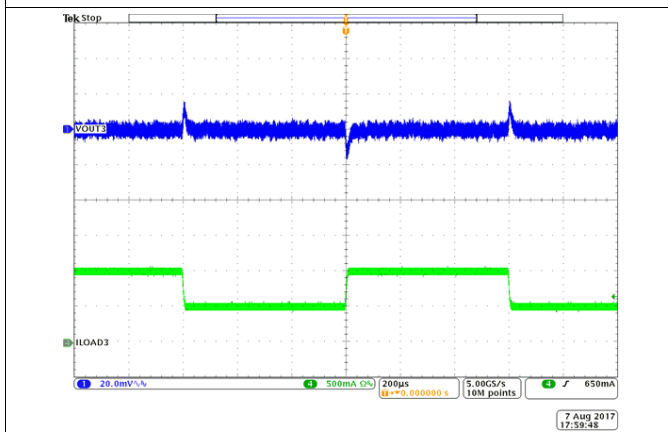

$I_{OUT} = 0.5$  to  $1$  A       $SR = 0.25$  A/ $\mu$ s

图 44. BUCK3 Load Transient

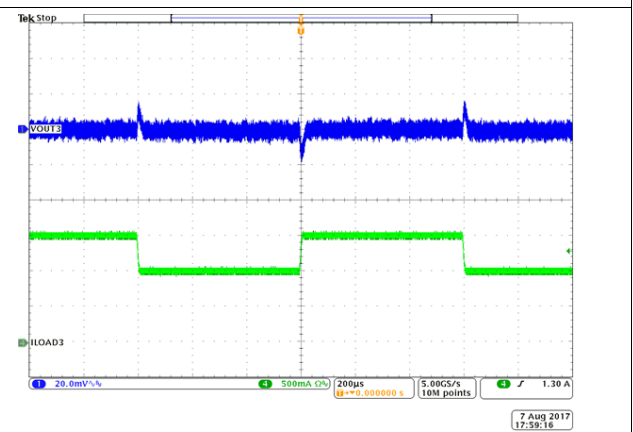

$I_{OUT} = 1$  to  $1.5$  A       $SR = 0.25$  A/ $\mu$ s

图 45. BUCK3 Load Transient



图 46. BUCK1 Hiccup and Recovery



图 47. BUCK2 Hiccup and Recovery

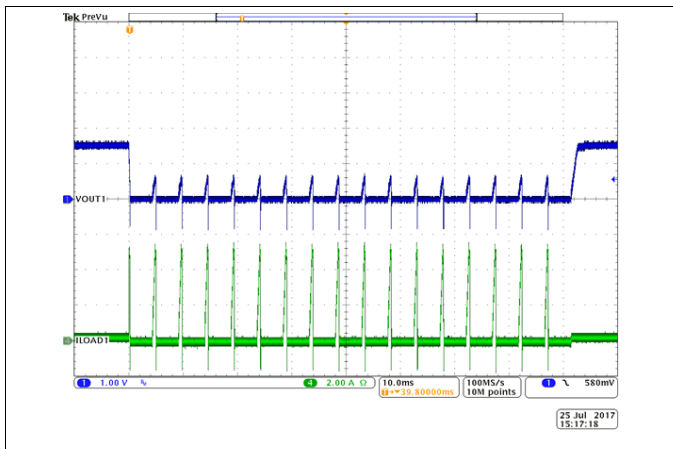

图 48. BUCK3 Hiccup and Recovery

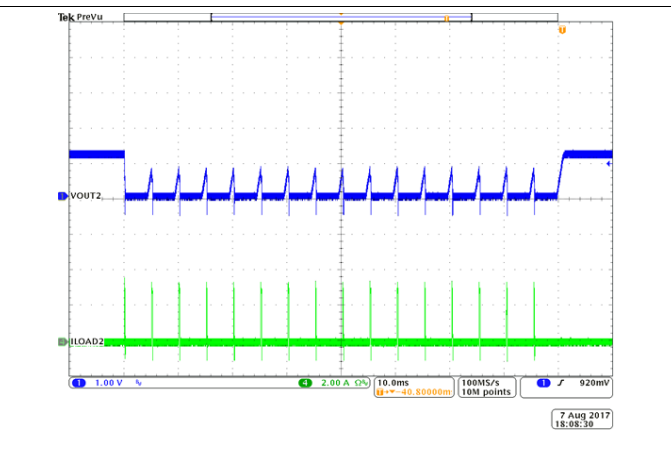

图 49. PGOOD

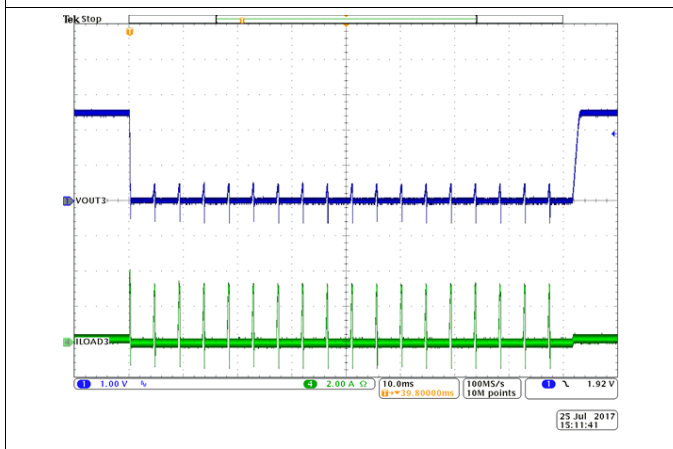

图 50. 180° Out-of-Phase

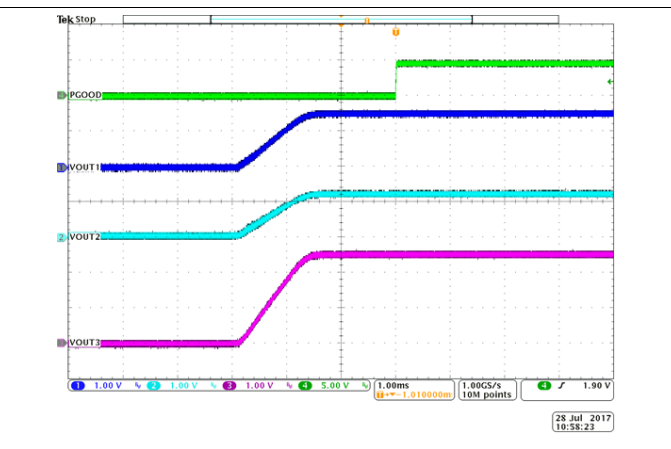

图 51. Synchronization With External Clock

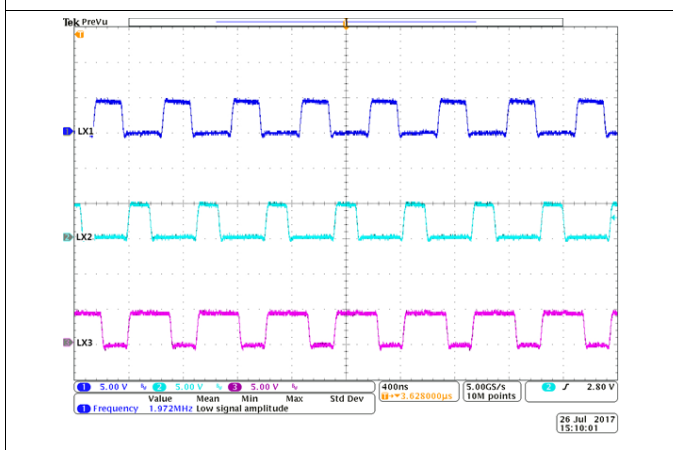

## 9 Power Supply Recommendations

The device is designed to operate from an input voltage supply range from 4 V to 8 V. This input power supply should be well regulated. If the input supply is located more than a few inches from the TPS65268-Q1 converter, additional bulk capacitance may be required in addition to the ceramic bypass capacitors. An electrolytic capacitor with a value of 47  $\mu$ F is a typical choice.

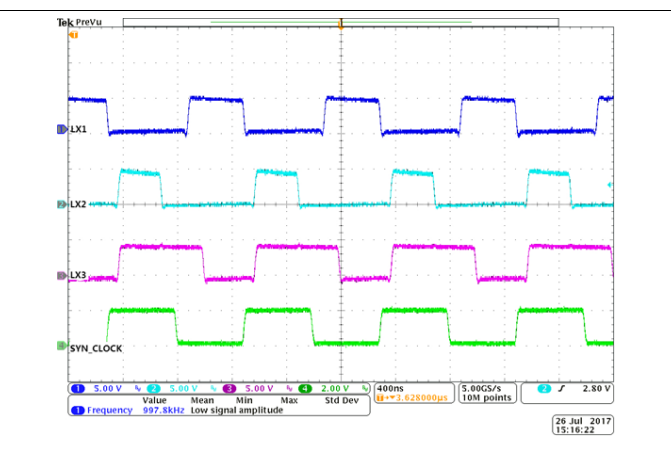
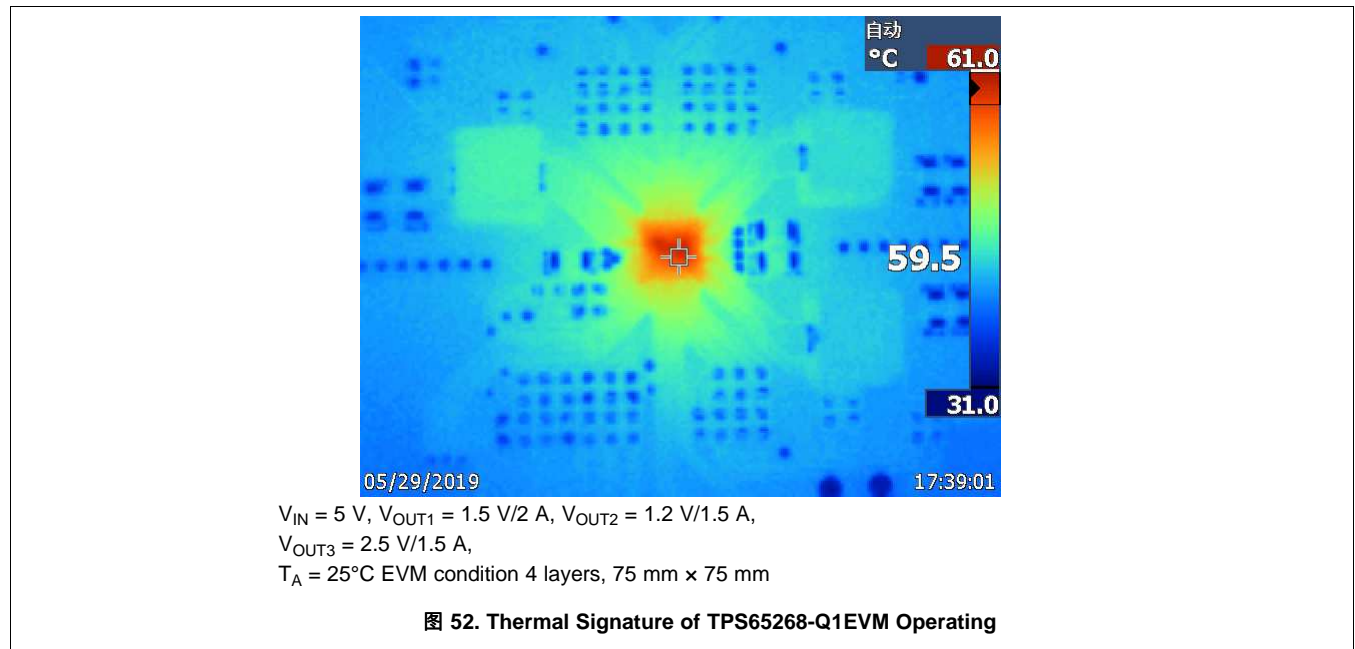
## 10 Layout

### 10.1 Layout Guidelines

 **53** shows the TPS65268-Q1 layout example on a 2-layer printed circuit board (PCB).

Layout is a critical portion of good power-supply design. The top layer contains the main power traces for PVIN, VOx, and LX. The top layer also has connections for the remaining pins of the TPS65268-Q1 device and a large top-side area filled with ground. The top-layer ground area should be connected to the bottom-layer ground using vias at the input bypass capacitor, the output filter capacitor, and directly under the TPS65268-Q1 device to provide a thermal path from the exposed thermal pad land to ground. The bottom layer acts as ground plane connecting analog ground and power ground.

For operation at full rated load, the top-side ground area together with the bottom-side ground plane must provide adequate heat dissipating area. Several signals paths conduct fast changing currents or voltages that can interact with stray inductance or parasitic capacitance to generate noise or degrade the performance of the power supplies. To help eliminate these problems, bypass the PVIN pin to ground with a low-ESR ceramic bypass capacitor with X5R or X7R dielectric. Take care to minimize the loop area formed by the bypass capacitor connections, the PVIN pins, and the ground connections. The VIN pin must also be bypassed to ground using a low-ESR ceramic capacitor with X5R or X7R dielectric.

Because the LX connection is the switching node, the output inductor should be located close to the LXx pins, and the area of the PCB conductor minimized to prevent excessive capacitive coupling. The output filter capacitor ground should use the same power ground trace as the PVIN input bypass capacitor. Try to minimize this conductor length while maintaining adequate width. The small signal components should be grounded to the analog ground path.

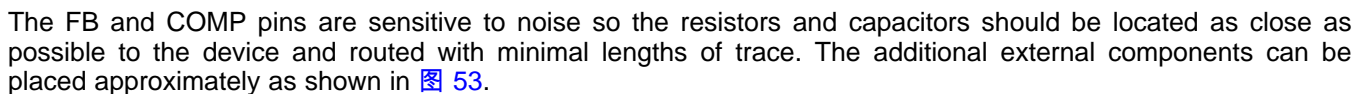
The FB and COMP pins are sensitive to noise so the resistors and capacitors should be located as close as possible to the device and routed with minimal lengths of trace. The additional external components can be placed approximately as shown in  **53**.

## 10.2 Layout Example



图 53. PCB Layout

## 11 器件和文档支持

### 11.1 接收文档更新通知

要接收文档更新通知，请导航至 [ti.com](http://ti.com) 上的器件产品文件夹。单击右上角的通知我进行注册，即可每周接收产品信息更改摘要。有关更改的详细信息，请查看任何已修订文档中包含的修订历史记录。

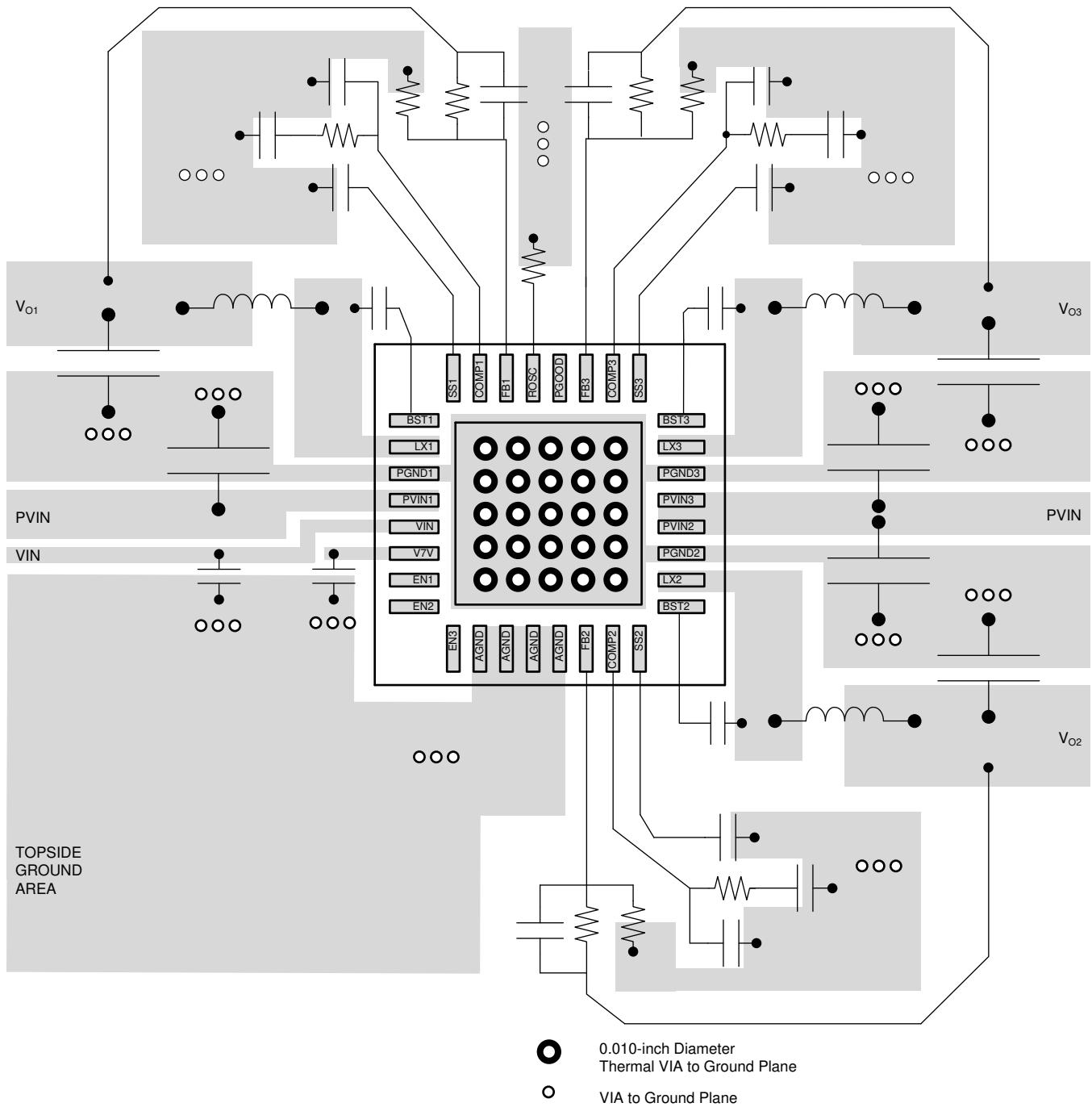
### 11.2 社区资源

The following links connect to TI community resources. Linked contents are provided "AS IS" by the respective contributors. They do not constitute TI specifications and do not necessarily reflect TI's views; see TI's [Terms of Use](#).

**TI E2E™ Online Community** *TI's Engineer-to-Engineer (E2E) Community*. Created to foster collaboration among engineers. At [e2e.ti.com](http://e2e.ti.com), you can ask questions, share knowledge, explore ideas and help solve problems with fellow engineers.

**Design Support** *TI's Design Support* Quickly find helpful E2E forums along with design support tools and contact information for technical support.

### 11.3 商标

E2E is a trademark of Texas Instruments.  
All other trademarks are the property of their respective owners.

### 11.4 静电放电警告



ESD 可能会损坏该集成电路。德州仪器 (TI) 建议通过适当的预防措施处理所有集成电路。如果不遵守正确的处理措施和安装程序，可能会损坏集成电路。

ESD 的损坏小至导致微小的性能降级，大至整个器件故障。精密的集成电路可能更容易受到损坏，这是因为非常细微的参数更改都可能会导致器件与其发布的规格不相符。

### 11.5 Glossary

**SLYZ022** — *TI Glossary*.

This glossary lists and explains terms, acronyms, and definitions.

## 12 机械、封装和可订购信息

以下页面包含机械、封装和可订购信息。这些信息是指定器件的最新可用数据。数据如有变更，恕不另行通知，且不会对此文档进行修订。如需获取此数据表的浏览器版本，请查阅左侧的导航栏。

## 重要声明和免责声明



TI 均以“原样”提供技术性及其可靠性数据（包括数据表）、设计资源（包括参考设计）、应用或其他设计建议、网络工具、安全信息和其他资源，不保证其中不含任何瑕疵，且不做任何明示或暗示的担保，包括但不限于对适销性、适合某特定用途或不侵犯任何第三方知识产权的暗示担保。

所述资源可供专业开发人员应用TI 产品进行设计使用。您将对以下行为独自承担全部责任：(1) 针对您的应用选择合适的TI 产品；(2) 设计、验证并测试您的应用；(3) 确保您的应用满足相应标准以及任何其他安全、安保或其他要求。所述资源如有变更，恕不另行通知。TI 对您使用所述资源的授权仅限于开发资源所涉及TI 产品的相关应用。除此之外不得复制或展示所述资源，也不提供其它TI 或任何第三方的知识产权授权许可。如因使用所述资源而产生任何索赔、赔偿、成本、损失及债务等，TI 对此概不负责，并且您须赔偿由此对TI 及其代表造成的损害。

TI 所提供产品均受TI 的销售条款 (<http://www.ti.com.cn/zh-cn/legal/termsofsale.html>) 以及ti.com.cn上或随附TI产品提供的其他可适用条款的约束。TI提供所述资源并不扩展或以其他方式更改TI 针对TI 产品所发布的可适用的担保范围或担保免责声明。

邮寄地址：上海市浦东新区世纪大道 1568 号中建大厦 32 楼，邮政编码：200122  
Copyright © 2019 德州仪器半导体技术（上海）有限公司

**PACKAGING INFORMATION**

Orderable Device	Status (1)	Package Type	Package Drawing	Pins	Package Qty	Eco Plan (2)	Lead finish/ Ball material (6)	MSL Peak Temp (3)	Op Temp (°C)	Device Marking (4/5)	Samples
TPS65268QRHBRQ1	ACTIVE	VQFN	RHB	32	3000	RoHS & Green	NIPDAU	Level-2-260C-1 YEAR	-40 to 125	TPS 268-1Q	
TPS65268QRHBTQ1	ACTIVE	VQFN	RHB	32	250	RoHS & Green	NIPDAU	Level-2-260C-1 YEAR	-40 to 125	TPS 268-1Q	

(1) The marketing status values are defined as follows:

**ACTIVE:** Product device recommended for new designs.

**LIFEBUY:** TI has announced that the device will be discontinued, and a lifetime-buy period is in effect.

**NRND:** Not recommended for new designs. Device is in production to support existing customers, but TI does not recommend using this part in a new design.

**PREVIEW:** Device has been announced but is not in production. Samples may or may not be available.

**OBsolete:** TI has discontinued the production of the device.

(2) **RoHS:** TI defines "RoHS" to mean semiconductor products that are compliant with the current EU RoHS requirements for all 10 RoHS substances, including the requirement that RoHS substance do not exceed 0.1% by weight in homogeneous materials. Where designed to be soldered at high temperatures, "RoHS" products are suitable for use in specified lead-free processes. TI may reference these types of products as "Pb-Free".

**RoHS Exempt:** TI defines "RoHS Exempt" to mean products that contain lead but are compliant with EU RoHS pursuant to a specific EU RoHS exemption.

**Green:** TI defines "Green" to mean the content of Chlorine (Cl) and Bromine (Br) based flame retardants meet JS709B low halogen requirements of <=1000ppm threshold. Antimony trioxide based flame retardants must also meet the <=1000ppm threshold requirement.

(3) MSL, Peak Temp. - The Moisture Sensitivity Level rating according to the JEDEC industry standard classifications, and peak solder temperature.

(4) There may be additional marking, which relates to the logo, the lot trace code information, or the environmental category on the device.

(5) Multiple Device Markings will be inside parentheses. Only one Device Marking contained in parentheses and separated by a "~" will appear on a device. If a line is indented then it is a continuation of the previous line and the two combined represent the entire Device Marking for that device.

(6) Lead finish/Ball material - Orderable Devices may have multiple material finish options. Finish options are separated by a vertical ruled line. Lead finish/Ball material values may wrap to two lines if the finish value exceeds the maximum column width.

**Important Information and Disclaimer:**The information provided on this page represents TI's knowledge and belief as of the date that it is provided. TI bases its knowledge and belief on information provided by third parties, and makes no representation or warranty as to the accuracy of such information. Efforts are underway to better integrate information from third parties. TI has taken and continues to take reasonable steps to provide representative and accurate information but may not have conducted destructive testing or chemical analysis on incoming materials and chemicals. TI and TI suppliers consider certain information to be proprietary, and thus CAS numbers and other limited information may not be available for release.

In no event shall TI's liability arising out of such information exceed the total purchase price of the TI part(s) at issue in this document sold by TI to Customer on an annual basis.

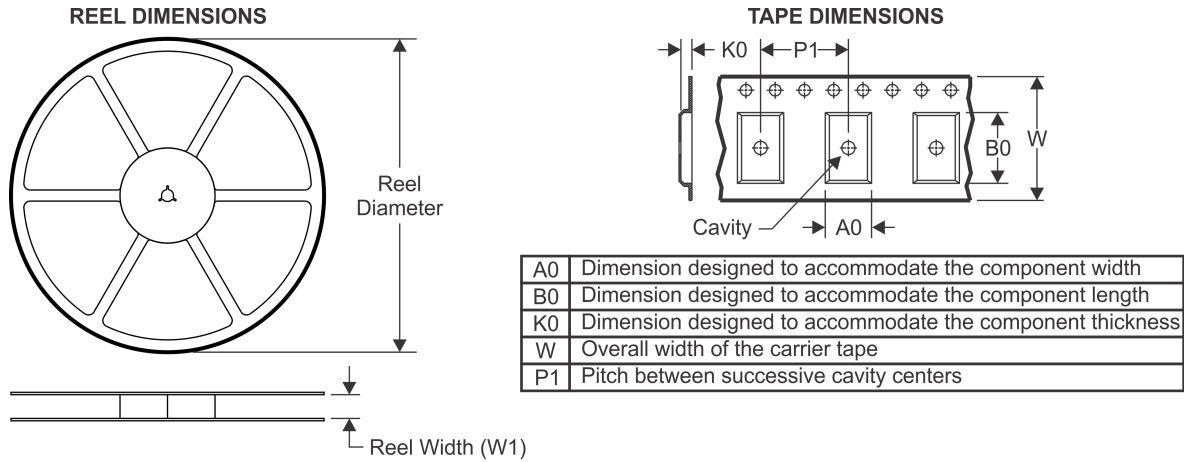
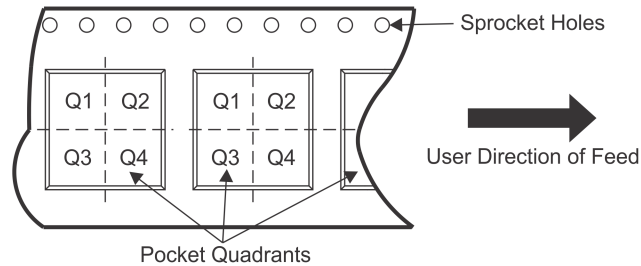

**TAPE AND REEL INFORMATION**

**QUADRANT ASSIGNMENTS FOR PIN 1 ORIENTATION IN TAPE**

\*All dimensions are nominal

Device	Package Type	Package Drawing	Pins	SPQ	Reel Diameter (mm)	Reel Width W1 (mm)	A0 (mm)	B0 (mm)	K0 (mm)	P1 (mm)	W (mm)	Pin1 Quadrant
TPS65268QRHBRQ1	VQFN	RHB	32	3000	330.0	12.4	5.3	5.3	1.1	8.0	12.0	Q2
TPS65268QRHBTQ1	VQFN	RHB	32	250	180.0	12.4	5.3	5.3	1.1	8.0	12.0	Q2

**TAPE AND REEL BOX DIMENSIONS**

\*All dimensions are nominal

Device	Package Type	Package Drawing	Pins	SPQ	Length (mm)	Width (mm)	Height (mm)
TPS65268QRHBRQ1	VQFN	RHB	32	3000	367.0	367.0	35.0
TPS65268QRHBTQ1	VQFN	RHB	32	250	210.0	185.0	35.0

## GENERIC PACKAGE VIEW

**RHB 32**

**VQFN - 1 mm max height**

5 x 5, 0.5 mm pitch

PLASTIC QUAD FLATPACK - NO LEAD

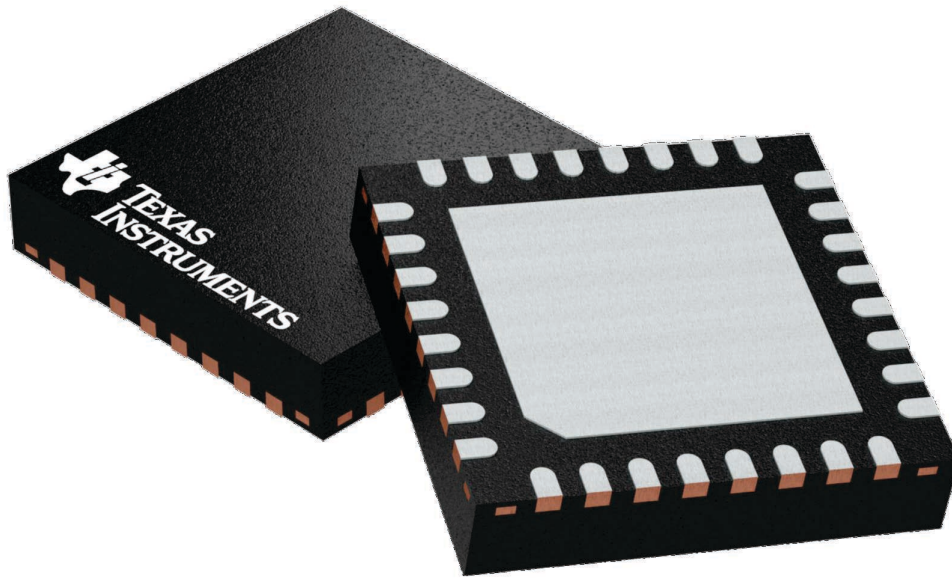

Images above are just a representation of the package family, actual package may vary.  
Refer to the product data sheet for package details.

4224745/A

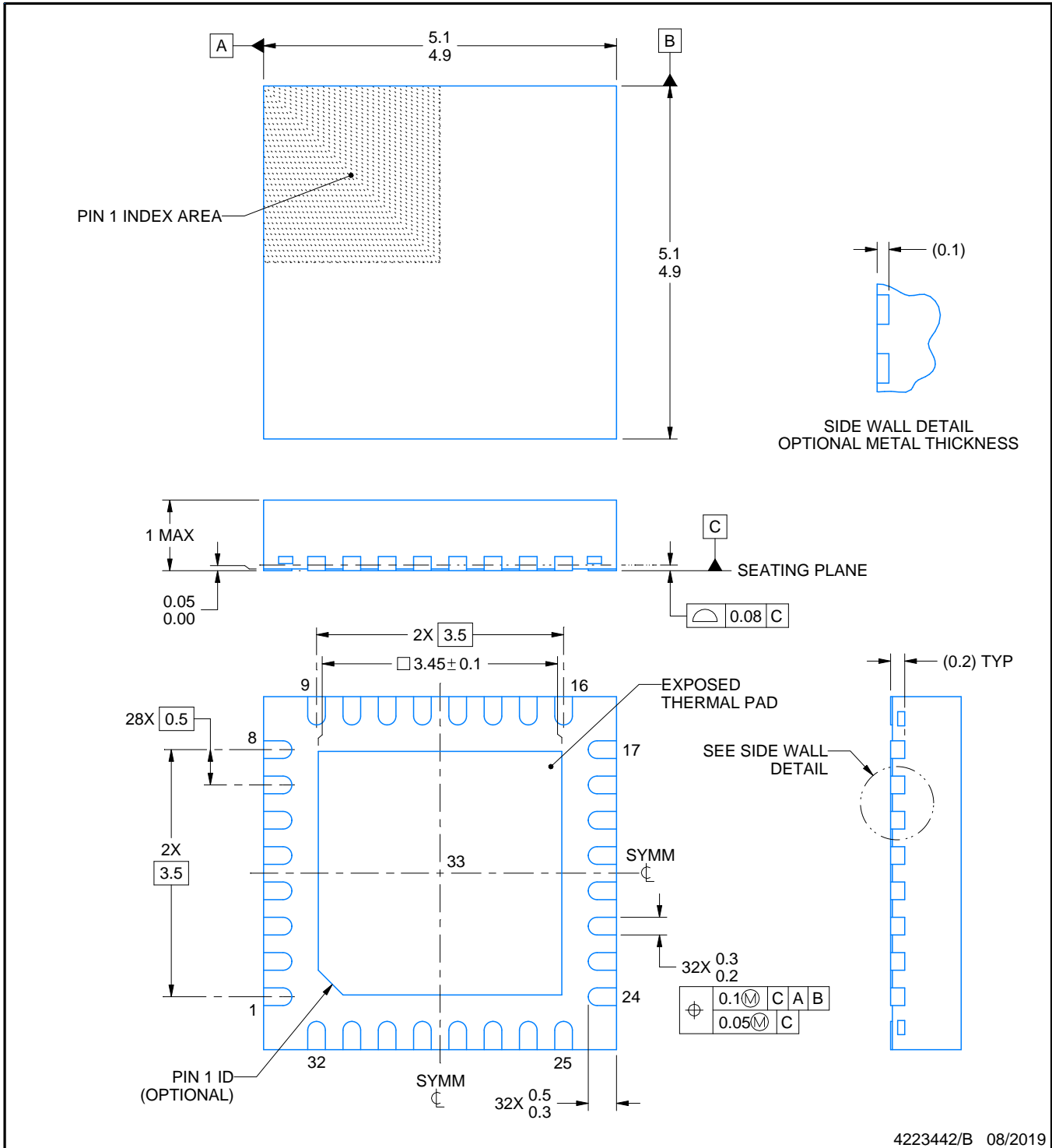
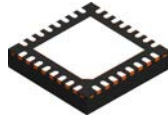

4223442/B 08/2019

NOTES:

1. All linear dimensions are in millimeters. Any dimensions in parenthesis are for reference only. Dimensioning and tolerancing per ASME Y14.5M.
2. This drawing is subject to change without notice.
3. The package thermal pad must be soldered to the printed circuit board for thermal and mechanical performance.

# EXAMPLE BOARD LAYOUT

RHB0032E

VQFN - 1 mm max height

PLASTIC QUAD FLATPACK - NO LEAD

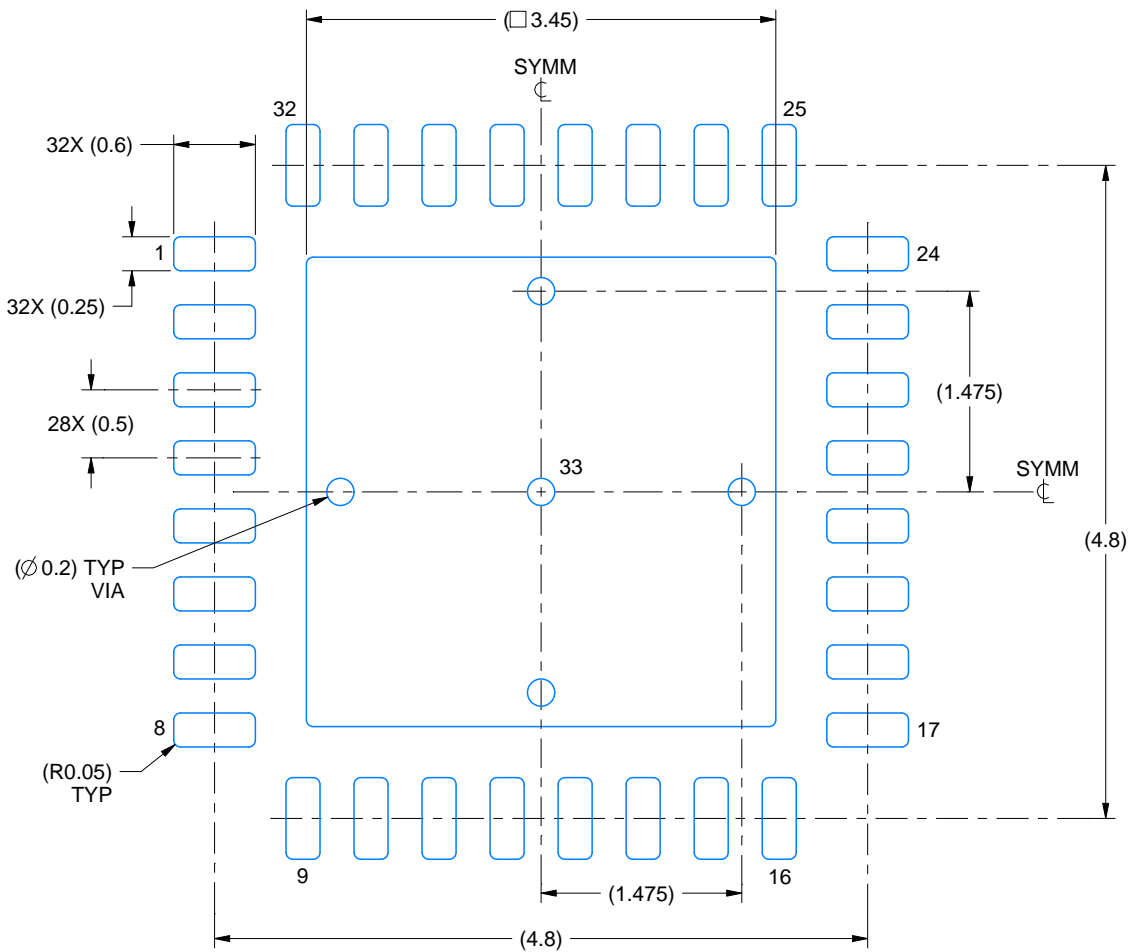

LAND PATTERN EXAMPLE  
SCALE:18X

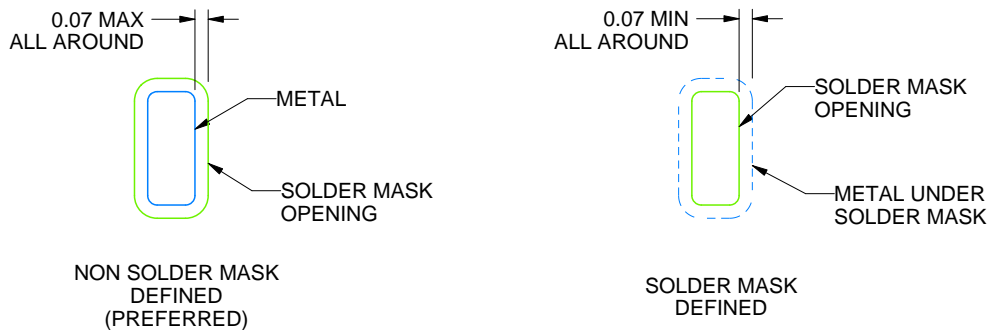

SOLDER MASK DETAILS

4223442/B 08/2019

NOTES: (continued)

4. This package is designed to be soldered to a thermal pad on the board. For more information, see Texas Instruments literature number SLUA271 ([www.ti.com/lit/sluea271](http://www.ti.com/lit/sluea271)).
5. Vias are optional depending on application, refer to device data sheet. If any vias are implemented, refer to their locations shown on this view. It is recommended that vias under paste be filled, plugged or tented.

# EXAMPLE STENCIL DESIGN

RHB0032E

VQFN - 1 mm max height

PLASTIC QUAD FLATPACK - NO LEAD

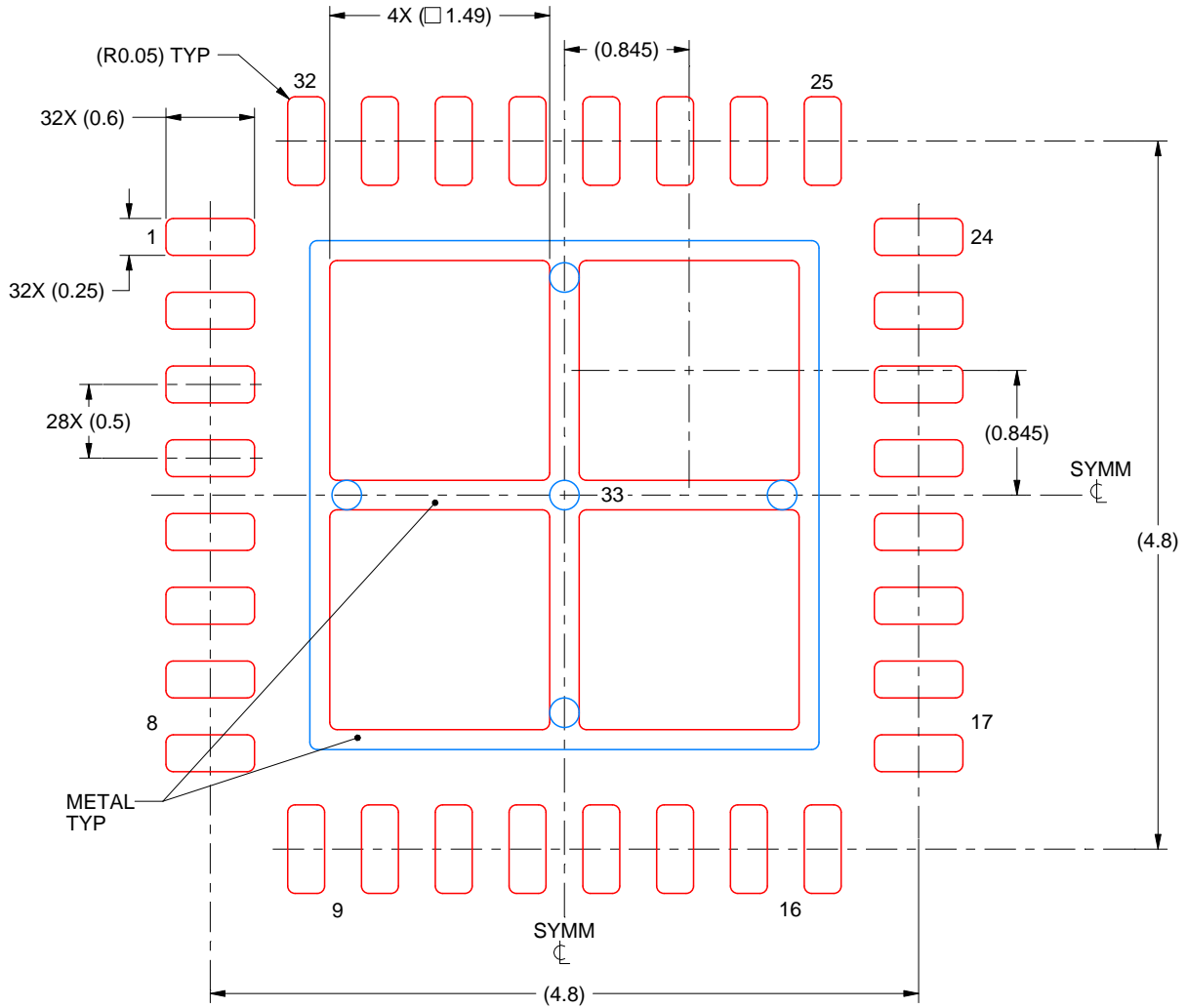

**SOLDER PASTE EXAMPLE**  
 BASED ON 0.125 mm THICK STENCIL

EXPOSED PAD 33:  
 75% PRINTED SOLDER COVERAGE BY AREA UNDER PACKAGE  
 SCALE:20X

4223442/B 08/2019

NOTES: (continued)

6. Laser cutting apertures with trapezoidal walls and rounded corners may offer better paste release. IPC-7525 may have alternate design recommendations.

## 重要声明和免责声明

TI 均以“原样”提供技术性及其可靠性数据（包括数据表）、设计资源（包括参考设计）、应用或其他设计建议、网络工具、安全信息和其他资源，不保证其中不含任何瑕疵，且不做任何明示或暗示的担保，包括但不限于对适销性、适合某特定用途或不侵犯任何第三方知识产权的暗示担保。

所述资源可供专业开发人员应用TI 产品进行设计使用。您将对以下行为独自承担全部责任：(1) 针对您的应用选择合适的TI 产品；(2) 设计、验证并测试您的应用；(3) 确保您的应用满足相应标准以及任何其他安全、安保或其他要求。所述资源如有变更，恕不另行通知。TI 对您使用所述资源的授权仅限于开发资源所涉及TI 产品的相关应用。除此之外不得复制或展示所述资源，也不提供其它TI 或任何第三方的知识产权授权许可。如因使用所述资源而产生任何索赔、赔偿、成本、损失及债务等，TI 对此概不负责，并且您须赔偿由此对TI 及其代表造成的损害。

TI 所提供产品均受TI 的销售条款 (<http://www.ti.com.cn/zh-cn/legal/termsofsale.html>) 以及ti.com.cn上或随附TI产品提供的其他可适用条款的约束。TI提供所述资源并不扩展或以其他方式更改TI 针对TI 产品所发布的可适用的担保范围或担保免责声明。

邮寄地址：上海市浦东新区世纪大道 1568 号中建大厦 32 楼，邮政编码：200122

Copyright © 2020 德州仪器半导体技术（上海）有限公司