

采用 WSON 封装的 LMR120xx 20V 输入电压、1.5A 或 2A 降压稳压器

1 特性

- 输入电压范围：3V 至 20V
- 输出电压范围：1V 至 18V
- LMR12015 和 LMR12020 分别提供最大值为 1.5A 和 2A 的输出电流
- 2MHz 开关频率
- 频率同步为 1MHz 至 2.35MHz
- 70nA 关断电流
- 1% 电压基准精度
- 峰值电流模式 PWM 操作
- 热关断
- 内部补偿
- 内部软启动
- 供电数字 IC 具有高精度
- 极易使用
- 微型整体解决方案降低了系统成本
- 节省空间的 WSON (3 × 3 × 0.8mm) 封装
- 使用 LMR12015 **WEBENCH**® 电源设计器或 LMR12020 **WEBENCH**® 电源设计器创建定制设计方案

2 应用

- 从 3.3V、5V 和 12V 电源轨到负载点的转换
- 空间受限型应用

3 说明

LMR120xx 稳压器是一款采用 10 引脚 WSON 封装的单片、高频、PWM 降压直流/直流转换器。该器件包含所有有效功能，从而在尽可能最小的 PCB 区域内提供具有快速瞬态响应和精确调节功能的本地直流/直流转换。

LMR12015/20 具有最少的外部组件，因而易于使用。该器件能够通过内部 150mΩ NMOS 开关来驱动 1.5A 或 2A 负载，从而实现最佳的功率密度。控制电路可实现低至 65ns 的导通时间，因而支持极高频率转换。开关频率在内部设置为 2MHz，并可在 1 至 2.35MHz 范围同步，从而允许使用极小的表面贴装电感器和片式电容器。尽管工作频率非常高，但仍可以轻松实现高达 90% 的效率。包括外部关断功能，该功能具有 70nA 的超低关断电流。LMR12015/20 利用峰值电流模式控制和内部补偿在各种运行条件下提供高性能调节。其他功能包括用于减小浪涌电流的内部软启动电路、逐脉冲电流限制、热关断和输出过压保护。

器件信息⁽¹⁾

器件型号	封装	封装尺寸 (标称值)
LMR12015	WSON (10)	3.00mm × 3.00mm
LMR12020		

(1) 如需了解所有可用封装，请参阅产品说明书末尾的可订购产品附录。

典型应用电路

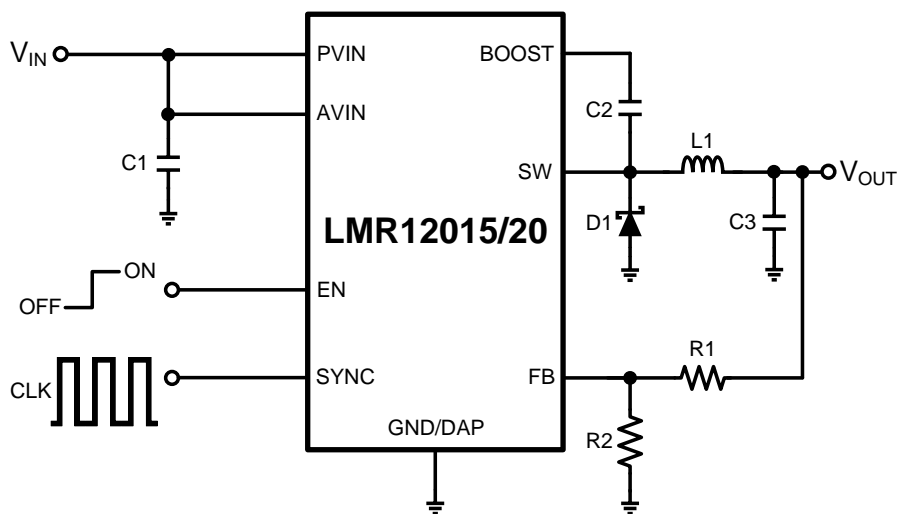

目录

1	特性	1	8	Application and Implementation	16
2	应用	1	8.1	Application Information.....	16
3	说明	1	8.2	Typical Application	16
4	修订历史记录	2	9	Layout	33
5	Pin Configuration and Functions	3	9.1	Layout Considerations	33
6	Specifications	4	10	器件和文档支持	35
6.1	Absolute Maximum Ratings	4	10.1	器件支持	35
6.2	Recommended Operating Ratings.....	4	10.2	相关链接	35
6.3	Electrical Characteristics.....	5	10.3	接收文档更新通知	35
6.4	Typical Performance Characteristics	6	10.4	社区资源	35
7	Detailed Description	10	10.5	商标	35
7.1	Overview	10	10.6	静电放电警告	36
7.2	Functional Block Diagram	11	10.7	Glossary	36
7.3	Feature Description.....	12	11	机械、封装和可订购信息	36
7.4	Device Operation Modes	14			

4 修订历史记录

注：之前版本的页码可能与当前版本有所不同。

Changes from Revision A (April 2013) to Revision B	Page
• 仅有编辑更改；添加了 WEBENCH 链接	1

Changes from Original (April 2013) to Revision A	Page
• 已更改 将美国国家半导体数据表的布局更改为 TI 格式	1

5 Pin Configuration and Functions

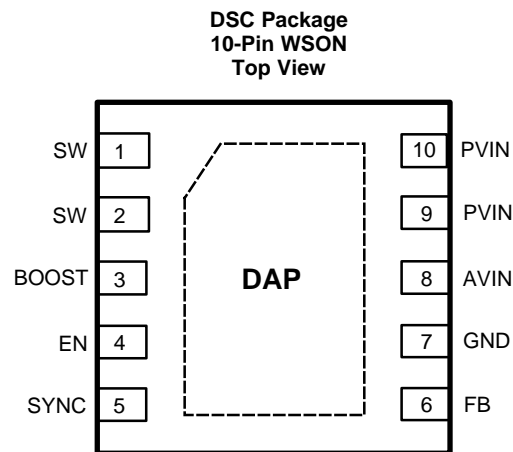

Pin Descriptions

PIN		DESCRIPTION
NO.	NAME	
1,2	SW	Output switch. Connects to the inductor, catch diode, and bootstrap capacitor.
3	BOOST	Boost voltage that drives the internal NMOS control switch. A bootstrap capacitor is connected between the BOOST and SW pins.
4	EN	Enable control input. Logic high enables operation. Do not allow this pin to float or be greater than $V_{IN} + 0.3\text{ V}$.
5	SYNC	Frequency synchronization input. Drive this pin with an external clock or pulse train. Ground it to use the internal clock.
6	FB	Feedback pin. Connect FB to the external resistor divider to set output voltage.
7	GND	Signal and Power Ground pin. Place the bottom resistor of the feedback network as close as possible to this pin for accurate regulation.
8	AVIN	Supply voltage for the control circuitry.
9,10	PVIN	Supply voltage for output power stage. Connect a bypass capacitor to this pin.
DAP	GND	Signal / Power Ground and thermal connection. Tie this directly to GND (pin 7). See regarding optimum thermal layout.

6 Specifications

6.1 Absolute Maximum Ratings

 See notes⁽¹⁾⁽²⁾

AVIN, PVIN	-0.5V to 24V
SW Voltage	-0.5V to 24V
Boost Voltage	-0.5V to 28V
Boost to SW Voltage	-0.5V to 6V
FB Voltage	-0.5V to 3V
SYNC Voltage	-0.5V to 6V
EN Voltage	-0.5V to ($V_{IN} + 0.3V$)
Storage Temperature Range	-65°C to +150°C
Junction Temperature	150°C
ESD Susceptibility ⁽³⁾	2kV
Soldering Information Infrared Reflow (5sec)	260°C

- (1) Absolute Maximum Ratings indicate limits beyond which damage to the device may occur, including inoperability and degradation of device reliability and/or performance. Functional operation of the device and/or non-degradation at the Absolute Maximum Ratings or other conditions beyond those indicated in the recommended Operating Ratings is not implied. The recommended Operating Ratings indicate conditions at which the device is functional and should not be operated beyond such conditions.
- (2) If Military/Aerospace specified devices are required, contact the Texas Instruments Sales Office/ Distributors for availability and specifications.
- (3) Human body model, 1.5 k Ω in series with 100 pF.

6.2 Recommended Operating Ratings

 See note⁽¹⁾

AVIN, PVIN	3V to 20V
SW Voltage	-0.5V to 20V
Boost Voltage	-0.5V to 24V
Boost to SW Voltage	3.0V to 5.5V
Junction Temperature Range	-40°C to +125°C
Thermal Resistance (θ_{JA}) WSON (DSC) ⁽²⁾	33°C/W

- (1) Absolute Maximum Ratings indicate limits beyond which damage to the device may occur, including inoperability and degradation of device reliability and/or performance. Functional operation of the device and/or non-degradation at the Absolute Maximum Ratings or other conditions beyond those indicated in the recommended Operating Ratings is not implied. The recommended Operating Ratings indicate conditions at which the device is functional and should not be operated beyond such conditions.
- (2) All numbers apply for packages soldered directly onto a 3" x 3" PC board with 2 oz. copper on 4 layers in still air.

6.3 Electrical Characteristics

Specifications with standard typeface are for $T_J = 25^\circ\text{C}$, and those in **boldface type** apply over the full **Operating Temperature Range** ($T_J = -40^\circ\text{C}$ to 125°C). $V_{IN} = 12\text{V}$, and $V_{BOOST} - V_{SW} = 4.3\text{V}$ unless otherwise specified. Datasheet min/max specification limits are ensured by design, test, or statistical analysis.

PARAMETER		TEST CONDITIONS	MIN	TYP	MAX	UNIT
SYSTEM PARAMETERS						
V_{FB}	Feedback Voltage	$T_J = 0^\circ\text{C}$ to 85°C	0.990	1.0	1.010	V
		$T_J = -40^\circ\text{C}$ to 125°C	0.984	1.0	1.014	
$\Delta V_{FB}/\Delta V_{IN}$	Feedback Voltage Line Regulation	$V_{IN} = 3\text{V}$ to 20V		0.003		% / V
I_{FB}	Feedback Input Bias Current			20	100	nA
OVP	Over Voltage Protection, V_{FB} at which PWM Halts.			1.13		V
UVLO	Undervoltage Lockout	V_{IN} Rising until V_{SW} is Switching	2.60	2.75	2.90	V
	UVLO Hysteresis	V_{IN} Falling from UVLO	0.30	0.47	0.6	
SS	Soft Start Time		0.5	1	1.5	ms
I_Q	Quiescent Current, $I_Q = I_{Q_AVIN} + I_{Q_PVIN}$	$V_{FB} = 1.1$ (not switching)		2.4		mA
	Quiescent Current, $I_Q = I_{Q_AVIN} + I_{Q_PVIN}$	$V_{EN} = 0\text{V}$ (shutdown)		70		nA
I_{BOOST}	Boost Pin Current	$f_{SW} = 2\text{ MHz}$		8.2	10	mA
		$f_{SW} = 1\text{ MHz}$		4.4	6	
OSCILLATOR						
f_{SW}	Switching Frequency	SYNC = GND	1.75	2	2.3	MHz
V_{FB_FOLD}	FB Pin Voltage where SYNC input is overridden.			0.53		V
f_{FOLD_MIN}	Frequency Foldback Minimum	$V_{FB} = 0\text{V}$		220	250	kHz
LOGIC INPUTS (EN, SYNC)						
f_{SYNC}	SYNC Frequency Range		1		2.35	MHz
V_{IL}	EN, SYNC Logic low threshold	Logic Falling Edge			0.4	V
V_{IH}	EN, SYNC Logic high threshold	Logic Rising Edge	1.8			
t_{SYNC_HIGH}	SYNC, Time Required above V_{IH} to Ensure a Logical High.		100			ns
t_{SYNC_LOW}	SYNC, Time Required below V_{IL} to Ensure a Logical Low.		100			ns
I_{SYNC}	SYNC Pin Current	$V_{SYNC} < 5\text{V}$		20		nA
I_{EN}	Enable Pin Current	$V_{EN} = 3\text{V}$		6	15	μA
		$V_{IN} = V_{EN} = 20\text{V}$		50	100	
INTERNAL MOSFET						
$R_{DS(ON)}$	Switch ON Resistance			150	320	m Ω
I_{CL}	Switch Current Limit	LMR12020	2.5		4.0	A
		LMR12015	2.0		3.7	
D_{MAX}	Maximum Duty Cycle	SYNC = GND	85	93%		
t_{MIN}	Minimum on time			65		ns
I_{SW}	Switch Leakage Current			40		nA
BOOST LDO						
V_{LDO}	Boost LDO Output Voltage			3.9		V
THERMAL						
T_{SHDN}	Thermal Shutdown Temperature ⁽¹⁾	Junction temperature rising		165		$^\circ\text{C}$
	Thermal Shutdown Hysteresis	Junction temperature hysteresis		15		$^\circ\text{C}$

(1) Thermal shutdown occurs if the junction temperature exceeds 165°C . The maximum power dissipation is a function of $T_{J(MAX)}$, θ_{JA} and T_A . The maximum allowable power dissipation at any ambient temperature is $P_D = (T_{J(MAX)} - T_A)/\theta_{JA}$.

6.4 Typical Performance Characteristics

All curves taken at $V_{IN} = 12\text{ V}$, $V_{BOOST} - V_{SW} = 4.3\text{ V}$ and $T_A = 25^\circ\text{C}$, unless specified otherwise.

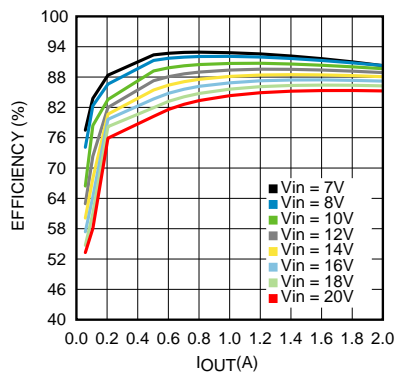

$V_{IN} = 5\text{ V}$ $f_{SW} = 2\text{ MHz}$
Refer To [Figure 37](#)

Figure 1. Efficiency vs Load Current

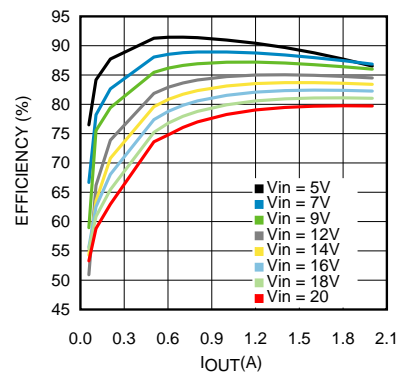

$V_{IN} = 3.3\text{ V}$ $f_{SW} = 2\text{ MHz}$
Refer To [Figure 39](#)

Figure 2. Efficiency vs Load Current

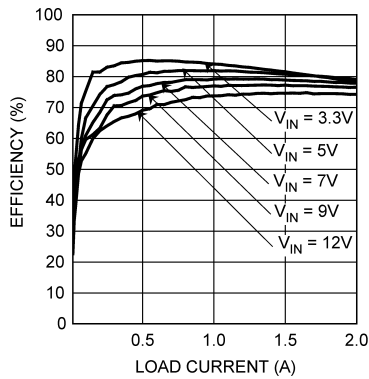

$V_{OUT} = 1.8\text{ V}$ $f_{SW} = 2\text{ MHz}$
Refer To [Figure 40](#)

Figure 3. Efficiency vs Load Current

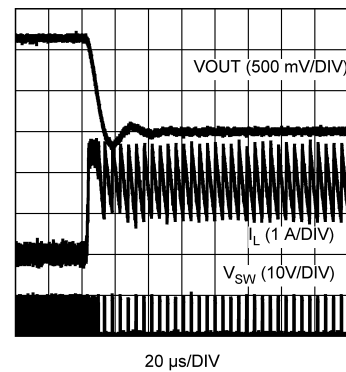

Figure 4. Short Circuit

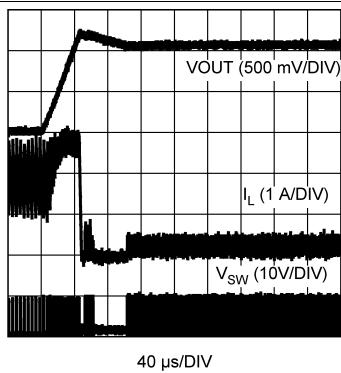

Figure 5. Short Circuit Release

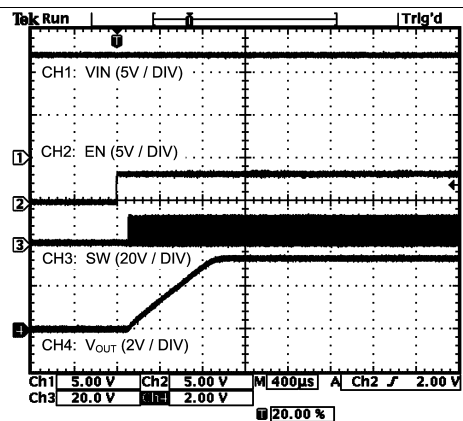

Figure 6. Soft Start

Typical Performance Characteristics (continued)

All curves taken at $V_{IN} = 12\text{ V}$, $V_{BOOST} - V_{SW} = 4.3\text{ V}$ and $T_A = 25^\circ\text{C}$, unless specified otherwise.

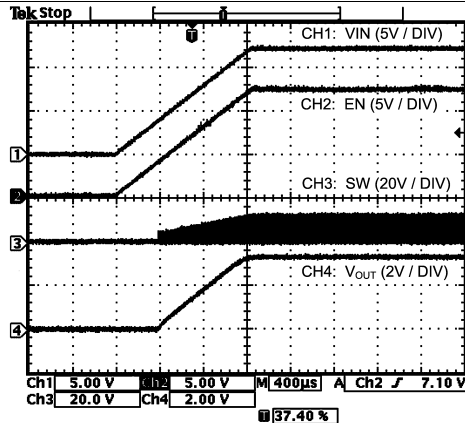

Figure 7. Soft Start With EN Tied To V_{IN}

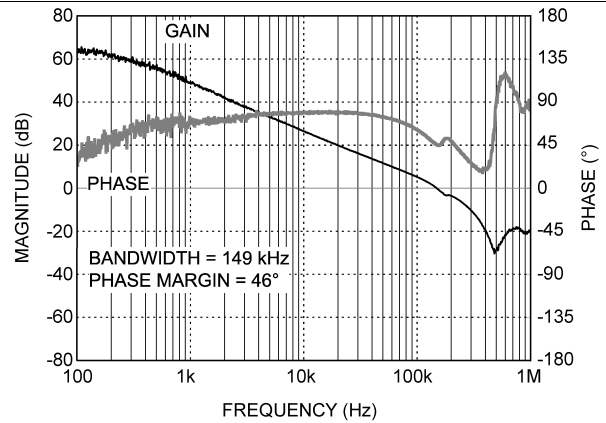

Figure 8. Magnitude vs Frequency

$V_{IN} = 12\text{ V}$ $V_{OUT} = 5\text{ V}$ $L = 2.2\text{ }\mu\text{H}$
 $C_{OUT} = 44\text{ }\mu\text{F}$ $I_{OUT} = 1\text{ A}$

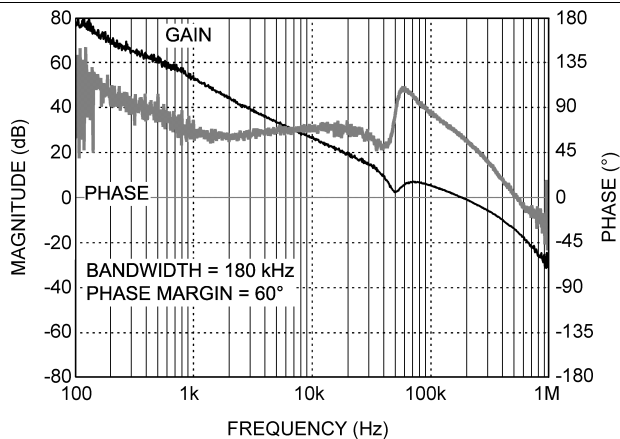

Figure 9. Magnitude vs Frequency

$V_{IN} = 12\text{ V}$ $V_{OUT} = 3.3\text{ V}$ $L = 1.5\text{ }\mu\text{H}$
 $C_{OUT} = 44\text{ }\mu\text{F}$ $I_{OUT} = 1\text{ A}$

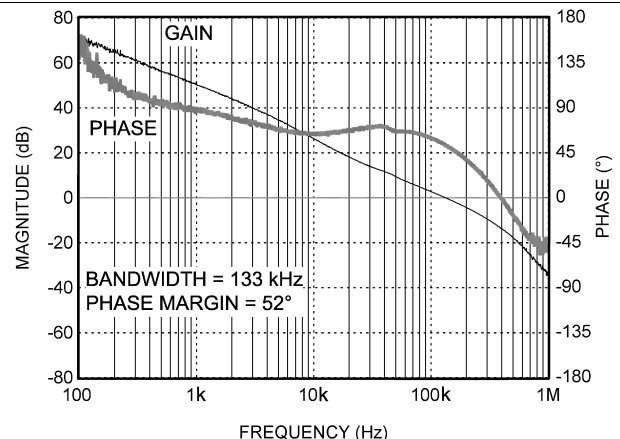

Figure 10. Magnitude vs Frequency

$V_{IN} = 5\text{ V}$ $V_{OUT} = 1.8\text{ V}$ $L = 1\text{ }\mu\text{H}$
 $C_{OUT} = 44\text{ }\mu\text{F}$ $I_{OUT} = 1\text{ A}$

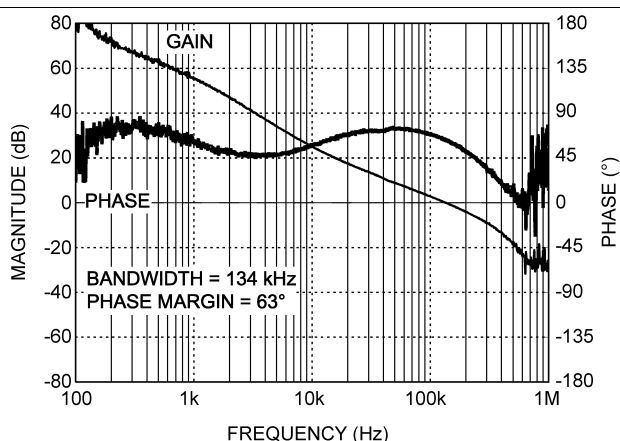

Figure 11. Magnitude vs Frequency

$V_{IN} = 5\text{ V}$ $V_{OUT} = 1.2\text{ V}$ $L = 0.56\text{ }\mu\text{H}$
 $C_{OUT} = 68\text{ }\mu\text{F}$ $I_{OUT} = 1\text{ A}$

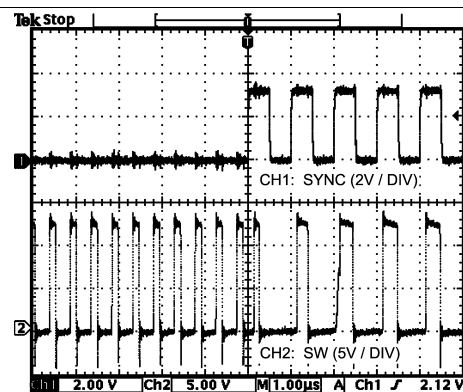

Figure 12. Sync Functionality

Typical Performance Characteristics (continued)

All curves taken at $V_{IN} = 12\text{ V}$, $V_{BOOST} - V_{SW} = 4.3\text{ V}$ and $T_A = 25^\circ\text{C}$, unless specified otherwise.

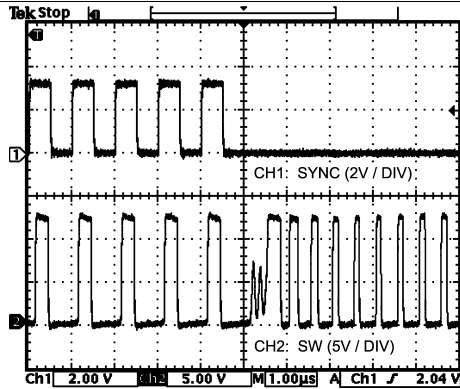
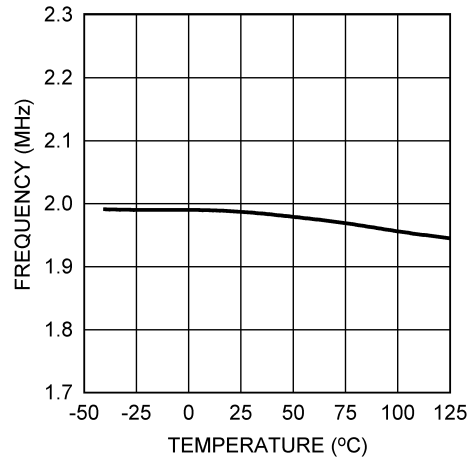
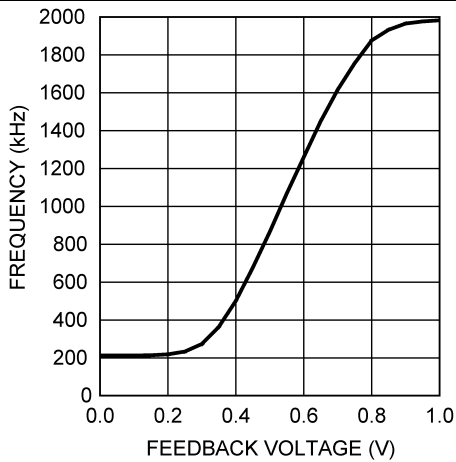

Figure 13. Loss Of Synchronization



$V_{SYNC} = \text{GND}$

Figure 14. Oscillator Frequency vs Temperature



$V_{SYNC} = \text{GND}$

Figure 15. Oscillator Frequency vs V_{FB}

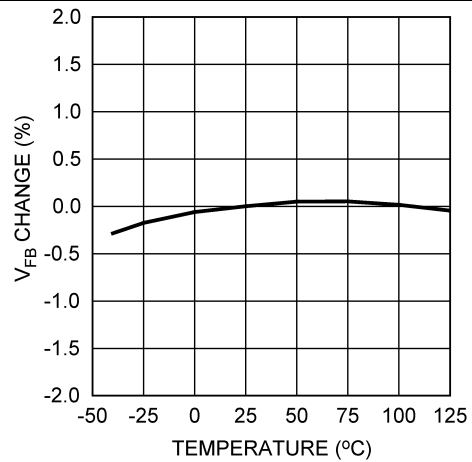

Figure 16. V_{FB} vs Temperature

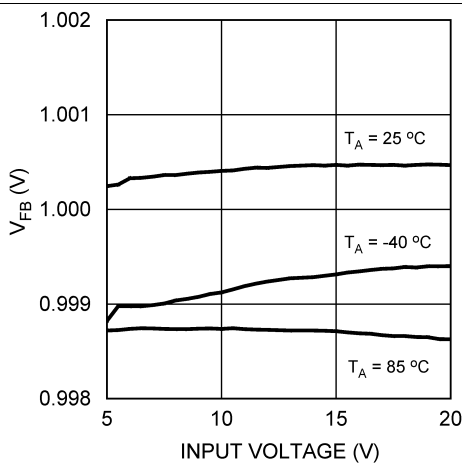
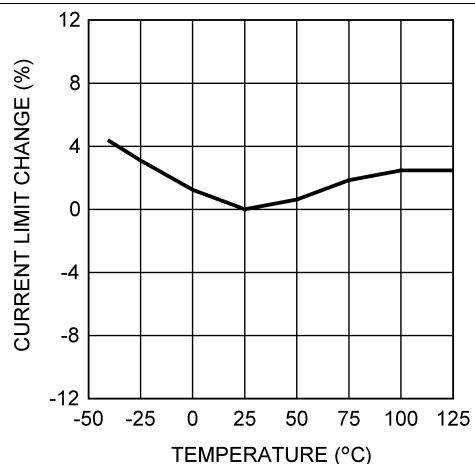

Figure 17. V_{FB} vs V_{IN}



$V_{IN} = 12\text{ V}$

Figure 18. Current Limit vs Temperature

Typical Performance Characteristics (continued)

All curves taken at $V_{IN} = 12\text{ V}$, $V_{BOOST} - V_{SW} = 4.3\text{ V}$ and $T_A = 25^\circ\text{C}$, unless specified otherwise.

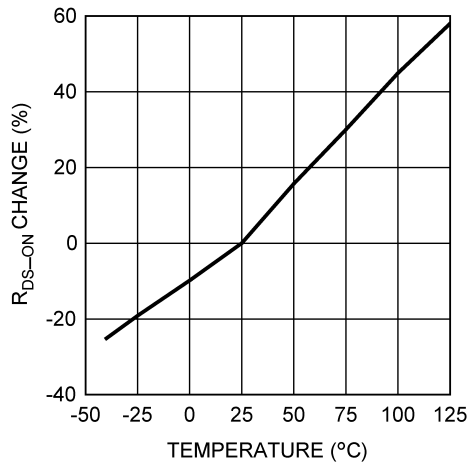

Figure 19. R_{DS(on)} vs Temperature

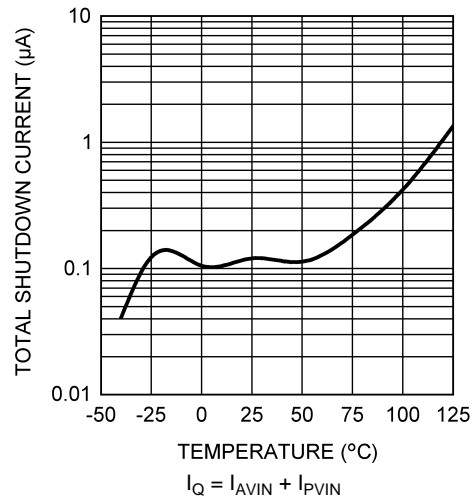

Figure 20. I_Q (Shutdown) vs Temperature

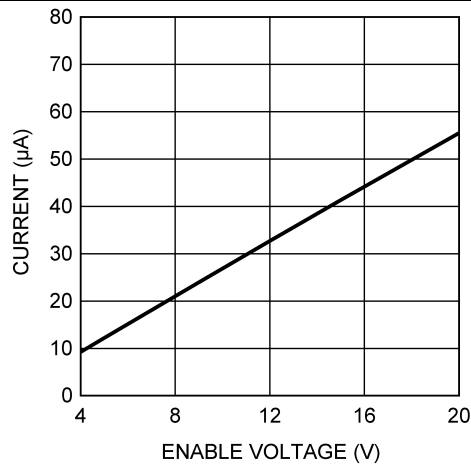

Figure 21. I_{EN} vs V_{EN}

7 Detailed Description

7.1 Overview

The LMR12015/20 is a constant-frequency, peak current-mode PWM buck regulator IC that delivers a 1.5-A or 2-A load current. The regulator has a preset switching frequency of 2 MHz. This high frequency allows the LMR12015/20 to operate with small surface mount capacitors and inductors, resulting in a DC/DC converter that requires a minimum amount of board space. The LMR12015/20 is internally compensated, which reduces design time, and requires few external components.

The following operating description of the LMR12015/20 will refer to the [Block Diagram](#) and to the waveforms in [Figure 22](#). The LMR12015/20 supplies a regulated output voltage by switching the internal NMOS switch at a constant frequency and varying the duty cycle. A switching cycle begins at the falling edge of the reset pulse generated by the internal oscillator. When this pulse goes low, the output control logic turns on the internal NMOS switch. During this on-time, the SW pin voltage (V_{SW}) swings up to approximately V_{IN} , and the inductor current (i_L) increases with a linear slope. The current-sense amplifier measures i_L , which generates an output proportional to the switch current typically called the sense signal. The sense signal is summed with the regulator's corrective ramp and compared to the error amplifier's output, which is proportional to the difference between the feedback voltage (V_{FB}) and V_{REF} . When the output of the PWM comparator goes high, the switch turns off until the next switching cycle begins. During the switch off-time (t_{OFF}), inductor current discharges through the catch diode D1, which forces the SW pin (V_{SW}) to swing below ground by the forward voltage (V_{D1}) of the catch diode. The regulator loop adjusts the duty cycle (D) to maintain a constant output voltage.

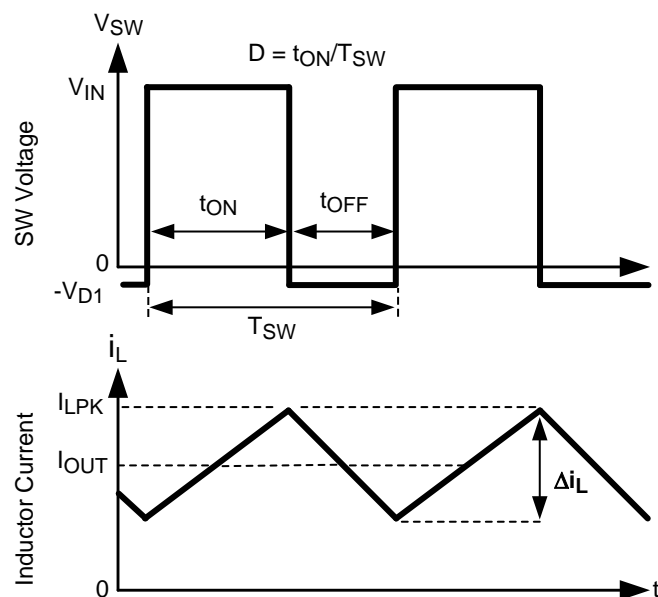
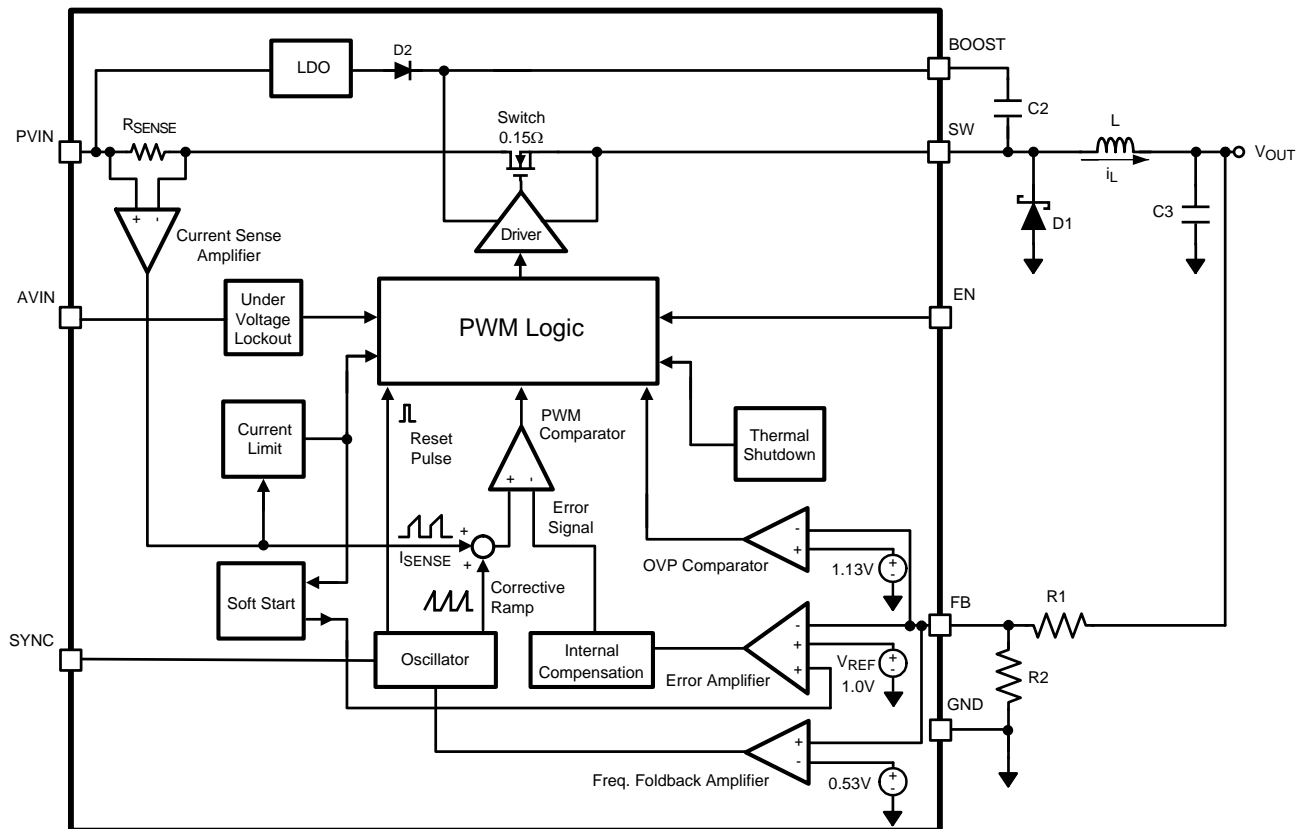

Figure 22. LMR12015/20 Waveforms of SW Pin Voltage and Inductor Current

7.2 Functional Block Diagram



7.3 Feature Description

7.3.1 Boost Function

Capacitor C_2 in , commonly referred to as C_{BOOST} , is used to store a voltage V_{BOOST} . When the LMR12015/20 starts up, an internal LDO charges C_{BOOST} , using an internal diode, to a voltage sufficient to turn the internal NMOS switch on. The gate drive voltage supplied to the internal NMOS switch is $V_{\text{BOOST}} - V_{\text{SW}}$.

During a normal switching cycle, when the internal NMOS control switch is off (t_{OFF}) (refer to [Figure 22](#)), V_{BOOST} equals V_{LDO} minus the forward voltage of the internal diode (V_{D2}). At the same time the inductor current (i_L) forward biases the catch diode D1 forcing the SW pin to swing below ground by the forward voltage drop of the catch diode (V_{D1}). Therefore, the voltage stored across C_{BOOST} is

$$V_{\text{BOOST}} - V_{\text{SW}} = V_{\text{LDO}} - V_{\text{D2}} + V_{\text{D1}} \quad (1)$$

Thus,

$$V_{\text{BOOST}} = V_{\text{SW}} + V_{\text{LDO}} - V_{\text{D2}} + V_{\text{D1}} \quad (2)$$

When the NMOS switch turns on (t_{ON}), the switch pin rises to

$$V_{\text{SW}} = V_{\text{IN}} - (R_{\text{DS(ON)}} \times I_L), \quad (3)$$

reverse biasing D1, and forcing V_{BOOST} to rise. The voltage at V_{BOOST} is then

$$V_{\text{BOOST}} = V_{\text{IN}} - (R_{\text{DS(ON)}} \times I_L) + V_{\text{LDO}} - V_{\text{D2}} + V_{\text{D1}} \quad (4)$$

which is approximately

$$V_{\text{IN}} + V_{\text{LDO}} - 0.4\text{V} \quad (5)$$

V_{BOOST} has pulled itself up by its "bootstraps", or boosted to a higher voltage.

7.3.2 Low Input Voltage Considerations

When the input voltage is below 5V and the duty cycle is greater than 75 percent, the gate drive voltage developed across C_{BOOST} might not be sufficient for proper operation of the NMOS switch. In this case, C_{BOOST} should be charged via an external Schottky diode attached to a 5-V voltage rail, see [Figure 23](#). This ensures that the gate drive voltage is high enough for proper operation of the NMOS switch in the triode region. Maintain $V_{\text{BOOST}} - V_{\text{SW}}$ less than the 6-V absolute maximum rating.

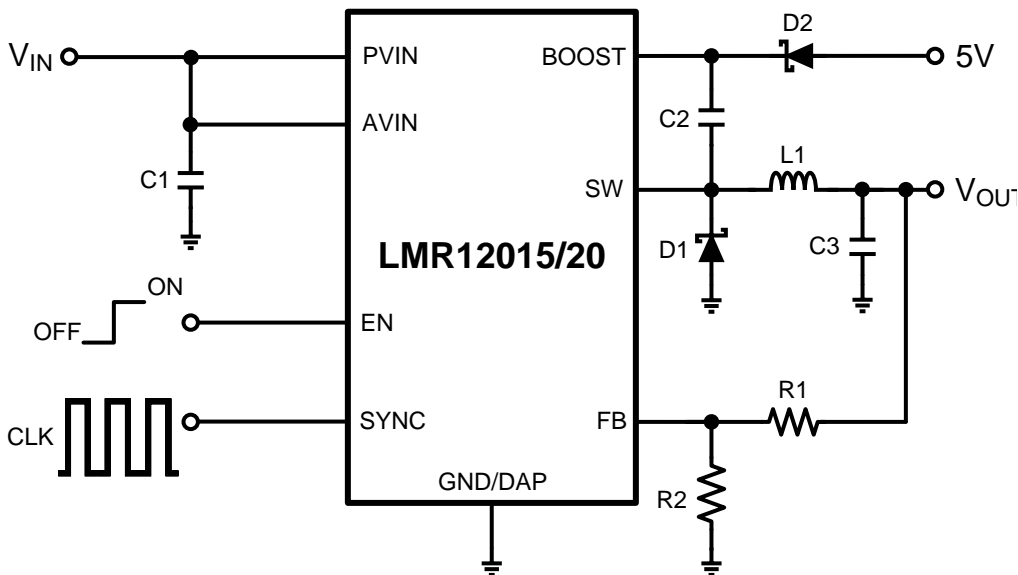

Figure 23. External Diode Charges C_{BOOST}

Feature Description (continued)

7.3.3 High Output Voltage Considerations

When the output voltage is greater than 3.3 V, a minimum load current is needed to charge C_{BOOST} , see Figure 24. The minimum load current forward biases the catch diode D1 forcing the SW pin to swing below ground. This allows C_{BOOST} to charge, ensuring that the gate drive voltage is high enough for proper operation. The minimum load current depends on many factors including the inductor value.

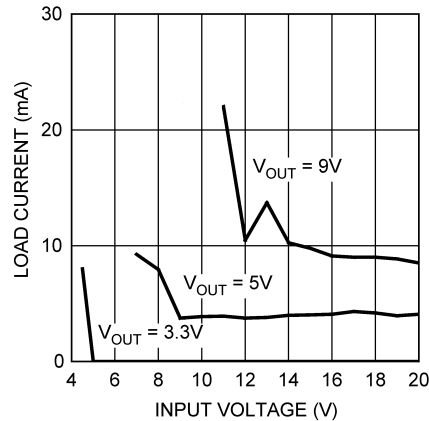

Figure 24. Minimum Load Current for L = 1.5 µH

7.3.4 Frequency Synchronization

The LMR12015/20 switching frequency can be synchronized to an external clock, between 1.00 and 2.35 MHz, applied at the SYNC pin. At the first rising edge applied to the SYNC pin, the internal oscillator is overridden and subsequent positive edges will initiate switching cycles. If the external SYNC signal is lost during operation, the LMR12015/20 reverts to its internal 2-MHz oscillator within 1.5 µs. To disable frequency synchronization and utilize the internal 2-MHz oscillator, connect the SYNC pin to GND.

The SYNC pin gives the designer the flexibility to optimize their design. A lower switching frequency can be chosen for higher efficiency. A higher switching frequency can be chosen to keep EMI out of sensitive ranges such as the AM radio band. Synchronization can also be used to eliminate beat frequencies generated by the interaction of multiple switching power converters. Synchronizing multiple switching power converters will result in cleaner power rails.

The selected switching frequency (f_{SYNC}) and the minimum on-time (t_{MIN}) limit the minimum duty cycle (D_{MIN}) of the device.

$$D_{MIN} = t_{MIN} \times f_{SYNC} \quad (6)$$

Operation below D_{MIN} is not recommended. The LMR12015/20 skips pulses to keep the output voltage in regulation, and the current limit is not ensured. The switching is in phase but no longer at the same switching frequency as the SYNC signal.

7.3.5 Current Limit

The LMR12015/20 use cycle-by-cycle current limiting to protect the output switch. During each switching cycle, a current limit comparator detects if the output switch current exceeds 2 A minimum (LMR12015) or 2.5 A minimum (LMR12020), and turns off the switch until the next switching cycle begins.

7.3.6 Frequency Foldback

The LMR12015/20 employs frequency foldback to protect the device from current run-away during output short-circuit. Once the FB pin voltage falls below regulation, the switch frequency will smoothly reduce with the falling FB voltage until the switch frequency reaches 220 kHz (typ). If the device is synchronized to an external clock, synchronization is disabled until the FB pin voltage exceeds 0.53V

Feature Description (continued)

7.3.7 Soft Start

The LMR12015/20 has a fixed internal soft start of 1 ms (typical). During soft start, the error amplifier reference voltage ramps from 0 V to its nominal value of 1 V in approximately 1 ms. This forces the regulator output to ramp in a controlled fashion, which helps reduce inrush current. Upon soft start the device initially is in frequency foldback, and the frequency rises as FB rises. The regulator will gradually rise to 2 MHz. The LMR12015/20 allows synchronization to an external clock at $FB > 0.53$ V.

7.3.8 Output Overvoltage Protection

The overvoltage comparator turns off the internal power NFET when the FB pin voltage exceeds the internal reference voltage by 13% ($V_{FB} > 1.13 \times V_{REF}$). With the power NFET turned off the output voltage decreases toward the regulation level.

7.3.9 Undervoltage Lockout

Undervoltage lockout (UVLO) prevents the LMR12015/20 from operating until the input voltage exceeds 2.75 V (typical).

The UVLO threshold has approximately 470 mV of hysteresis, so the device operates until V_{IN} drops below 2.28 V (typical). Hysteresis prevents the part from turning off during power up if V_{IN} has finite impedance.

7.3.10 Thermal Shutdown

Thermal shutdown limits total power dissipation by turning off the internal NMOS switch when the IC junction temperature exceeds 165°C (typ). After thermal shutdown occurs, hysteresis prevents the internal NMOS switch from turning on until the junction temperature drops to approximately 150°C.

7.4 Device Operation Modes

7.4.1 Enable Pin / Shutdown Mode

Connect the EN pin to a voltage source greater than 1.8V to enable operation of the LMR12015/20. Apply a voltage less than 0.4V to put the part into shutdown mode. In shutdown mode the quiescent current drops to typically 70 nA. Switch leakage adds another 40 nA from the input supply. For proper operation, the LMR12015/20 EN pin should never be left floating, and the voltage should never exceed $V_{IN} + 0.3$ V.

The simplest way to enable the operation of the LMR12015/20 is to connect the EN pin to AVIN which allows self start-up of the LMR12015/20 when the input voltage is applied.

When the rise time of V_{IN} is longer than the soft-start time of the LMR12015/20 this method may result in an overshoot in output voltage. In such applications, the EN pin voltage can be controlled by a separate logic signal, or tied to a resistor divider, which reaches 1.8V after V_{IN} is fully established (see [Figure 25](#)). This will minimize the potential for output voltage overshoot during a slow V_{IN} ramp condition. Use the lowest value of V_{IN} , seen in your application when calculating the resistor network, to ensure that the 1.8-V minimum EN threshold is reached.

Device Operation Modes (continued)

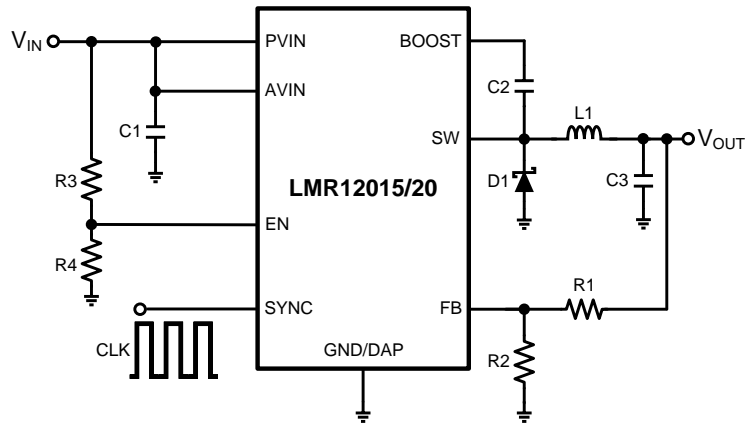

Figure 25. Resistor Divider on EN

$$R3 = \left(\frac{V_{IN}}{1.8} - 1 \right) \times R4$$

(7)

8 Application and Implementation

NOTE

Information in the following applications sections is not part of the TI component specification, and TI does not warrant its accuracy or completeness. TI's customers are responsible for determining suitability of components for their purposes. Customers should validate and test their design implementation to confirm system functionality.

8.1 Application Information

The LMR10530 regulator is a monolithic, high frequency, PWM step-down DC/DC converter available in a 10-pin WSON package. It contains all the active functions to provide local DC/DC conversion with fast transient response and accurate regulation in the smallest possible PCB area. With a minimum of external components, the LMR10530 is easy to use. Switching frequency is internally set to 1.5 MHz or 3 MHz, allowing the use of extremely small surface mount inductors and capacitors. Even though the operating frequency is high, efficiencies up to 93% are easy to achieve.

8.2 Typical Application

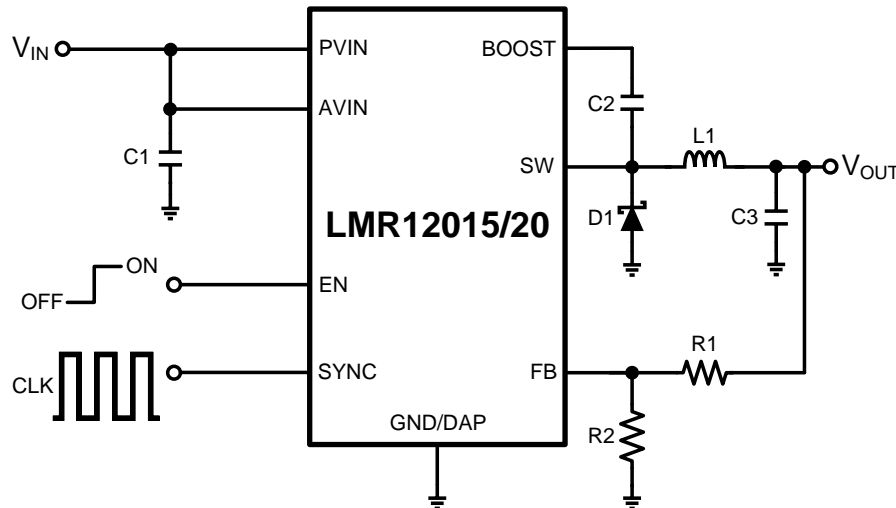

Figure 26. Typical Application Schematic

8.2.1 Detailed Design Procedure

8.2.1.1 Custom Design With WEBENCH® Tools

[Click here](#) to create a custom design using the LMR12015 device with the WEBENCH® Power Designer.

1. Start by entering the input voltage (V_{IN}), output voltage (V_{OUT}), and output current (I_{OUT}) requirements.
2. Optimize the design for key parameters such as efficiency, footprint, and cost using the optimizer dial.
3. Compare the generated design with other possible solutions from Texas Instruments.

The WEBENCH Power Designer provides a customized schematic along with a list of materials with real-time pricing and component availability.

In most cases, these actions are available:

- Run electrical simulations to see important waveforms and circuit performance
- Run thermal simulations to understand board thermal performance
- Export customized schematic and layout into popular CAD formats
- Print PDF reports for the design, and share the design with colleagues

Get more information about WEBENCH tools at www.ti.com/WEBENCH.

Typical Application (continued)

8.2.1.2 Inductor Selection

Inductor selection is critical to the performance of the LMR12015/20. The selection of the inductor affects stability, transient response and efficiency. A key factor in inductor selection is determining the ripple current (Δi_L) (see [Figure 22](#)).

The ripple current (Δi_L) is important in many ways.

First, by allowing more ripple current, lower inductance values can be used with a corresponding decrease in physical dimensions and improved transient response. On the other hand, allowing less ripple current will increase the maximum achievable load current and reduce the output voltage ripple (see [Output Capacitor](#) section for more details on calculating output voltage ripple). Increasing the maximum load current is achieved by ensuring that the peak inductor current (I_{LPK}) never exceeds the minimum current limit of 2 A minimum (LMR12015) or 2.5 A minimum (LMR12020) .

$$I_{LPK} = I_{OUT} + \Delta i_L / 2 \quad (8)$$

Secondly, the slope of the ripple current affects the current control loop. The LMR12015/20 has a fixed slope corrective ramp. When the slope of the current ripple becomes significantly less than the converter's corrective ramp (see), the inductor pole will move from high frequencies to lower frequencies. This negates one advantage that peak current-mode control has over voltage-mode control, which is, a single low frequency pole in the power stage of the converter. This can reduce the phase margin, crossover frequency and potentially cause instability in the converter. Contrarily, when the slope of the ripple current becomes significantly greater than the converter's corrective ramp, resonant peaking can occur in the control loop. This can also cause instability (sub-harmonic oscillation) in the converter. For the power supply designer this means that for lower switching frequencies the current ripple must be increased to keep the inductor pole well above crossover. It also means that for higher switching frequencies the current ripple must be decreased to avoid resonant peaking.

With all these factors, how is the desired ripple current selected? The ripple ratio (r) is defined as the ratio of inductor ripple current (Δi_L) to output current (I_{OUT}), evaluated at maximum load:

$$r = \frac{\Delta i_L}{I_{OUT}} \quad (9)$$

A good compromise between physical size, transient response and efficiency is achieved when we set the ripple ratio between 0.2 and 0.4. The recommended ripple ratio vs. duty cycle shown below (see [Figure 27](#)) is based upon this compromise and control loop optimizations. Note that this is just a guideline. See Application note AN-1197 [AN-1197 Selecting Inductors for Buck Converters](#) for further considerations.

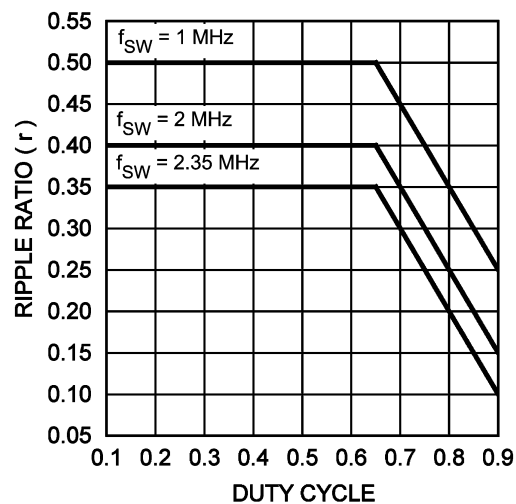

Figure 27. Recommended Ripple Ratio vs Duty Cycle

The duty cycle (D) can be approximated quickly using the ratio of output voltage (V_{OUT}) to input voltage (V_{IN}):

Typical Application (continued)

$$D = \frac{V_{OUT}}{V_{IN}} \quad (10)$$

Use the application's lowest input voltage to calculate the ripple ratio. The catch diode forward voltage drop (V_{D1}) and the voltage drop across the internal NFET (V_{DS}) must be included to calculate a more accurate duty cycle. Calculate D by using the following formula:

$$D = \frac{V_{OUT} + V_{D1}}{V_{IN} + V_{D1} - V_{DS}} \quad (11)$$

V_{DS} can be approximated by:

$$V_{DS} = I_{OUT} \times R_{DS(ON)} \quad (12)$$

The diode forward drop (V_{D1}) can range from 0.3 V to 0.5 V depending on the quality of the diode. The lower V_{D1} is, the higher the operating efficiency of the converter.

Now that the ripple current or ripple ratio is determined, the required inductance is calculated by:

$$L = \frac{V_{OUT} + V_{D1}}{I_{OUT} \times r \times f_{SW}} \times (1 - D_{MIN})$$

where

- D_{MIN} is the duty cycle calculated with the maximum input voltage
 - f_{SW} is the switching frequency
 - I_{OUT} is the maximum output current of 2 A
- (13)

Using $I_{OUT} = 2$ A minimizes the inductor's physical size.

8.2.1.2.1 Inductor Calculation Example

Operating conditions for the LMR12015/20 are:

$$V_{IN} = 7 - 16 \text{ V} \quad (14)$$

$$f_{SW} = 2 \text{ MHz} \quad (15)$$

$$V_{OUT} = 3.3 \text{ V} \quad (16)$$

$$V_{D1} = 0.5 \text{ V} \quad (17)$$

$$I_{OUT} = 2 \text{ A} \quad (18)$$

First the maximum duty cycle is calculated.

$$D_{MAX} = (V_{OUT} + V_{D1}) / (V_{IN} + V_{D1} - V_{DS}) = (3.3 \text{ V} + 0.5 \text{ V}) / (7 \text{ V} + 0.5 \text{ V} - 0.3 \text{ V}) = 0.528 \quad (19)$$

Using [Figure 27](#) gives us a recommended ripple ratio = 0.4.

Now the minimum duty cycle is calculated.

$$D_{MIN} = (V_{OUT} + V_{D1}) / (V_{IN} + V_{D1} - V_{DS}) = (3.3 \text{ V} + 0.5 \text{ V}) / (16 \text{ V} + 0.5 \text{ V} - 0.3 \text{ V}) = 0.235 \quad (20)$$

The inductance can now be calculated.

$$L = (1 - D_{MIN}) \times (V_{OUT} + V_{D1}) / (I_{OUT} \times r \times f_{SW}) = (1 - 0.235) \times (3.3 \text{ V} + 0.5 \text{ V}) / (2 \text{ A} \times 0.4 \times 2 \text{ MHz}) = 1.817 \text{ } \mu\text{H} \quad (21)$$

This is close to the standard inductance value of 1.8 μH . This leads to a 1% deviation from the recommended ripple ratio, which is now 0.4038.

Finally, we check that the peak current does not reach the minimum current limit of 2.5 A.

$$I_{LPK} = I_{OUT} \times (1 + r / 2) = 2 \text{ A} \times (1 + 0.4038 / 2) = 2.404 \text{ A} \quad (22)$$

The peak current is less than 2.5 A, so the DC load specification can be met with this ripple ratio. To design for the LMR12015 simply replace $I_{OUT} = 1.5$ A in the equations for I_{LPK} and see that I_{LPK} does not exceed the LMR12015 current limit of 2 A (min).

Typical Application (continued)

8.2.1.2.2 Inductor Material Selection

When selecting an inductor, make sure that it is capable of supporting the peak output current without saturating. Inductor saturation will result in a sudden reduction in inductance and prevent the regulator from operating correctly. To prevent the inductor from saturating over the entire -40°C to $+125^{\circ}\text{C}$ range, pick an inductor with a saturation current higher than the upper limit of I_{CL} listed in [Electrical Characteristics](#).

Ferrite core inductors are recommended to reduce AC loss and fringing magnetic flux. The drawback of ferrite core inductors is their quick saturation characteristic. The current limit circuit has a propagation delay and so is oftentimes not fast enough to stop a saturated inductor from going above the current limit. This has the potential to damage the internal switch. To prevent a ferrite core inductor from getting into saturation, the inductor saturation current rating should be higher than the switch current limit I_{CL} . The LMR12015/20 is quite robust in handling short pulses of current that are a few amps above the current limit. Saturation protection is provided by a second current limit which is 30% higher than the cycle-by-cycle current limit. When the saturation protection is triggered the device turns off the output switch and attempt to soft start. (When a compromise has to be made, pick an inductor with a saturation current just above the lower limit of the I_{CL} .) Be sure to validate the short-circuit protection over the intended temperature range.

An inductor's saturation current is usually lower when hot. Consult the inductor vendor if the saturation current rating is only specified at room temperature.

Soft saturation inductors such as the iron powder types can also be used. Such inductors do not saturate suddenly and therefore are safer when there is a severe overload or even shorted output. Their physical sizes are usually smaller than the Ferrite core inductors. The downside is their fringing flux and higher power dissipation due to relatively high AC loss, especially at high frequencies.

8.2.1.3 Input Capacitor

An input capacitor is necessary to ensure that V_{IN} does not drop excessively during switching transients. The primary specifications of the input capacitor are capacitance, voltage, RMS current rating, and equivalent series inductance (ESL). The recommended input capacitance is $10\ \mu\text{F}$, although $4.7\ \mu\text{F}$ works well for input voltages below $6\ \text{V}$. The input voltage rating is specifically stated by the capacitor manufacturer. Make sure to check any recommended deratings and also verify if there is any significant change in capacitance at the operating input voltage and the operating temperature. The input capacitor maximum RMS input current rating (I_{RMS-IN}) must be greater than:

$$I_{RMS-IN} = I_{OUT} \times \sqrt{D \times \left(1 - D + \frac{r^2}{12}\right)}$$

where

- r is the ripple ratio defined earlier
- I_{OUT} is the output current, and
- D is the duty cycle

(23)

It can be shown from the above equation that maximum RMS capacitor current occurs when $D = 0.5$. Always calculate the RMS at the point where the duty cycle, D , is closest to 0.5. The ESL of an input capacitor is usually determined by the effective cross sectional area of the current path. A large leaded capacitor will have high ESL and a 0805 ceramic chip capacitor will have very low ESL. At the operating frequencies of the LMR12015/20, certain capacitors may have an ESL so large that the resulting impedance ($2\pi fL$) is higher than that required to provide stable operation. As a result, surface mount capacitors are strongly recommended. Sanyo POSCAP, Tantalum or Niobium, Panasonic SP or Cornell Dubilier Low ESR are all good choices for input capacitors and have acceptable ESL. Multilayer ceramic capacitors (MLCC) have very low ESL. For MLCCs TI recommends using X7R or X5R dielectrics. Consult the capacitor manufacturer's datasheet to see how rated capacitance varies over operating conditions.

Typical Application (continued)

8.2.1.4 Output Capacitor

The output capacitor is selected based upon the desired output ripple and transient response. The LMR12015/20's loop compensation is designed for ceramic capacitors. A minimum of 22 μF is required at 2 MHz (33 μF at 1 MHz) while 47 – 100 μF is recommended for improved transient response and higher phase margin. The output voltage ripple of the converter is:

$$\Delta V_{\text{OUT}} = \Delta i_{\text{L}} \times \left(R_{\text{ESR}} + \frac{1}{8 \times f_{\text{SW}} \times C_{\text{OUT}}} \right) \quad (24)$$

When using MLCCs, the ESR is typically so low that the capacitive ripple may dominate. When this occurs, the output ripple is approximately sinusoidal and 90° phase shifted from the switching action. Another benefit of ceramic capacitors is their ability to bypass high frequency noise. A certain amount of switching edge noise will couple through parasitic capacitances in the inductor to the output. A ceramic capacitor will bypass this noise while a tantalum will not.

The transient response is determined by the speed of the control loop and the ability of the output capacitor to provide the initial current of a load transient. Capacitance can be increased significantly with little detriment to the regulator stability. However, increasing the capacitance provides diminishing improvement over 100 μF in most applications, because the bandwidth of the control loop decreases as output capacitance increases. If improved transient performance is required, add a feed forward capacitor. This becomes especially important for higher output voltages where the bandwidth of the LMR12015/20 is lower. See [Feedforward Capacitor \(Optional\)](#) and [Frequency Synchronization](#) sections.

Check the RMS current rating of the capacitor. The RMS current rating of the capacitor chosen must also meet the following condition:

$$I_{\text{RMS-OUT}} = I_{\text{OUT}} \times \frac{r}{\sqrt{12}}$$

where

- I_{OUT} is the output current, and
- r is the ripple ratio.

(25)

8.2.1.5 Catch Diode

The catch diode (D1) conducts during the switch off-time. A Schottky diode is recommended for its fast switching times and low forward voltage drop. The catch diode should be chosen so that its current rating is greater than:

$$I_{\text{D1}} = I_{\text{OUT}} \times (1-D) \quad (26)$$

The reverse breakdown rating of the diode must be at least the maximum input voltage plus appropriate margin. To improve efficiency choose a Schottky diode with a low forward voltage drop.

8.2.1.6 Boost Diode (Optional)

For circuits with input voltages $V_{\text{IN}} < 5 \text{ V}$ and duty cycles $(D) > 0.75$, a small-signal Schottky diode is recommended. A good choice is the BAT54 small signal diode. The cathode of the diode is connected to the BOOST pin and the anode to a 5-V voltage rail.

8.2.1.7 Boost Capacitor

A ceramic 0.1- μF capacitor with a voltage rating of at least 6.3 V is sufficient. The X7R and X5R MLCCs provide the best performance.

8.2.1.8 Output Voltage

The output voltage is set using [Equation 27](#) where R2 is connected between the FB pin and GND, and R1 is connected between V_{OUT} and the FB pin. A good starting value for R2 is 1 k Ω .

$$R1 = \left(\frac{V_{\text{OUT}}}{V_{\text{REF}}} - 1 \right) \times R2 \quad (27)$$

Typical Application (continued)

8.2.1.9 Feedforward Capacitor (Optional)

A feed forward capacitor C_{FF} can improve the transient response of the converter. Place C_{FF} in parallel with $R1$. The value of C_{FF} should place a zero in the loop response at, or above, the pole of the output capacitor and R_{LOAD} . The C_{FF} capacitor will increase the crossover frequency of the design, thus a larger minimum output capacitance is required for designs using C_{FF} . C_{FF} must only be used with an output capacitance greater than or equal to 44 μF . Example waveforms of load transient with and without the C_{FF} capacitors are as shown below.

$$C_{FF} \leq \frac{V_{OUT} \times C_{OUT}}{I_{OUT} \times R1} \tag{28}$$

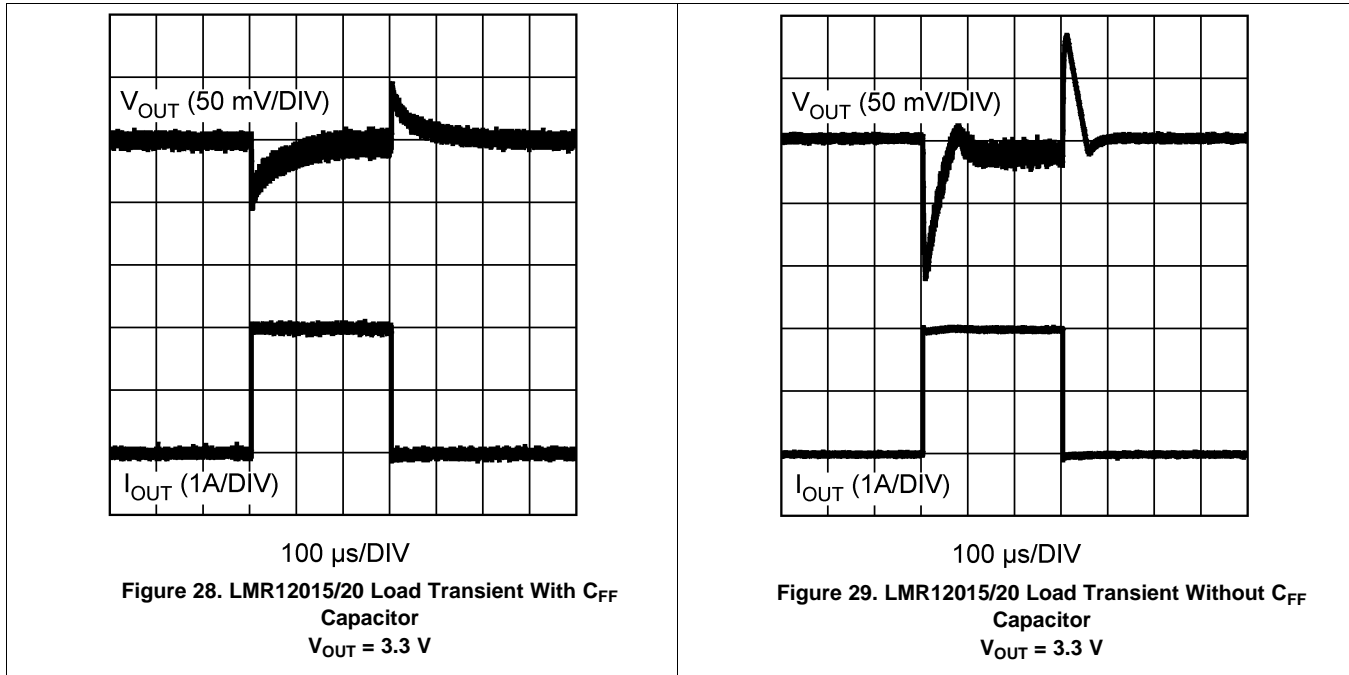

8.2.1.10 Calculating Efficiency and Junction Temperature

The complete LMR12015/20 DC/DC converter efficiency can be calculated in the following manner.

$$\eta = \frac{P_{OUT}}{P_{IN}} \tag{29}$$

Or

$$\eta = \frac{P_{OUT}}{P_{OUT} + P_{LOSS}} \tag{30}$$

Calculations for determining the most significant power losses are following. Other losses totaling less than 2% are not discussed.

Power loss (P_{LOSS}) is the sum of two basic types of losses in the converter, switching and conduction. Conduction losses usually dominate at higher output loads, where as switching losses remain relatively fixed and dominate at lower output loads. The first step in determining the losses is to calculate the duty cycle (D).

$$D = \frac{V_{OUT} + V_{D1}}{V_{IN} + V_{D1} - V_{DS}} \tag{31}$$

V_{DS} is the voltage drop across the internal NFET when it is on, and is equal to:

Typical Application (continued)

$$V_{DS} = I_{OUT} \times R_{DS(on)} \quad (32)$$

V_D is the forward voltage drop across the Schottky diode. It can be obtained from the Electrical Characteristics section of the schottky diode datasheet. If the voltage drop across the inductor (V_{DCR}) is accounted for, the equation becomes:

$$D = \frac{V_{OUT} + V_{D1} + V_{DCR}}{V_{IN} + V_{D1} - V_{DS}} \quad (33)$$

V_{DCR} usually gives only a minor duty cycle change, and has been omitted in the examples for simplicity.

8.2.1.10.1 Schottky Diode Conduction Losses

The conduction losses in the free-wheeling Schottky diode are calculated as follows:

$$P_{DIODE} = V_{D1} \times I_{OUT} (1 - D) \quad (34)$$

Often this is the single most significant power loss in the circuit. Take care to choose a Schottky diode that has a low forward voltage drop.

8.2.1.10.2 Inductor Conduction Losses

Another significant external power loss is the conduction loss in the output inductor. The equation can be simplified to:

$$P_{IND} = I_{OUT}^2 \times R_{DCR} \quad (35)$$

8.2.1.10.3 MOSFET Conduction Losses

The LMR12015/20 conduction loss is mainly associated with the internal NFET:

$$P_{COND} = I_{OUT}^2 \times R_{DS(on)} \times D \quad (36)$$

8.2.1.10.4 MOSFET Switching Losses

Switching losses are also associated with the internal NFET. They occur during the switch on and off transition periods, where voltages and currents overlap resulting in power loss. The simplest means to determine this loss is to empirically measure the rise and fall times (10% to 90%) of the switch at the switch node:

$$P_{SWF} = 1/2(V_{IN} \times I_{OUT} \times f_{SW} \times t_{FALL}) \quad (37)$$

$$P_{SWR} = 1/2(V_{IN} \times I_{OUT} \times f_{SW} \times t_{RISE}) \quad (38)$$

$$P_{SW} = P_{SWF} + P_{SWR} \quad (39)$$

Table 1. Typical Rise and Fall Times vs Input Voltage

V_{IN}	t_{RISE}	t_{FALL}
5 V	8 ns	8 ns
10 V	9 ns	9ns
15 V	10 ns	10 ns

8.2.1.10.5 IC Quiescent Losses

Another loss is the power required for operation of the internal circuitry:

$$P_Q = I_Q \times V_{IN} \quad (40)$$

I_Q is the quiescent operating current, and is typically around 2.4 mA.

8.2.1.10.6 MOSFET Driver Losses

The other operating power that needs to be calculated is that required to drive the internal NFET:

$$P_{BOOST} = I_{BOOST} \times V_{BOOST} \quad (41)$$

V_{BOOST} is normally between 3 VDC and 5 VDC. The I_{BOOST} rms current is dependant on switching frequency f_{SW} . I_{BOOST} is approximately 8.2 mA at 2 MHz and 4.4 mA at 1 MHz.

8.2.1.10.7 Total Power Losses

Total power losses are:

$$P_{\text{LOSS}} = P_{\text{COND}} + P_{\text{SWR}} + P_{\text{SWF}} + P_{\text{Q}} + P_{\text{BOOST}} + P_{\text{DIODE}} + P_{\text{IND}} \quad (42)$$

Losses internal to the LMR12015/20 are:

$$P_{\text{INTERNAL}} = P_{\text{COND}} + P_{\text{SWR}} + P_{\text{SWF}} + P_{\text{Q}} + P_{\text{BOOST}} \quad (43)$$

8.2.1.10.8 Efficiency Calculation Example

Operating conditions are:

$$V_{\text{IN}} = 12 \text{ V} \quad (44)$$

$$f_{\text{SW}} = 2 \text{ MHz} \quad (45)$$

$$V_{\text{OUT}} = 3.3 \text{ V} \quad (46)$$

$$V_{\text{D1}} = 0.5 \text{ V} \quad (47)$$

$$I_{\text{OUT}} = 2 \text{ A} \quad (48)$$

$$R_{\text{DCR}} = 20 \text{ m}\Omega \quad (49)$$

Internal Power Losses are:

$$P_{\text{COND}} = I_{\text{OUT}}^2 \times R_{\text{DS(ON)}} \times D = 2^2 \times 0.15 \Omega \times 0.314 = 188 \text{ mW} \quad (50)$$

$$P_{\text{SW}} = (V_{\text{IN}} \times I_{\text{OUT}} \times f_{\text{SW}} \times t_{\text{FALL}}) = (12 \text{ V} \times 2 \text{ A} \times 2 \text{ MHz} \times 10 \text{ ns}) = 480 \text{ mW} \quad (51)$$

$$P_{\text{Q}} = I_{\text{Q}} \times V_{\text{IN}} = 2.4 \text{ mA} \times 12 \text{ V} = 29 \text{ mW} \quad (52)$$

$$P_{\text{BOOST}} = I_{\text{BOOST}} \times V_{\text{BOOST}} = 8.2 \text{ mA} \times 4.5 \text{ V} = 37 \text{ mW} \quad (53)$$

$$P_{\text{INTERNAL}} = P_{\text{COND}} + P_{\text{SW}} + P_{\text{Q}} + P_{\text{BOOST}} = 733 \text{ mW} \quad (54)$$

Total power losses are:

$$P_{\text{DIODE}} = V_{\text{D1}} \times I_{\text{OUT}} (1 - D) = 0.5 \text{ V} \times 2 \times (1 - 0.314) = 686 \text{ mW} \quad (55)$$

$$P_{\text{IND}} = I_{\text{OUT}}^2 \times R_{\text{DCR}} = 2^2 \times 20 \text{ m}\Omega = 80 \text{ mW} \quad (56)$$

$$P_{\text{LOSS}} = P_{\text{INTERNAL}} + P_{\text{DIODE}} + P_{\text{IND}} = 1.499 \text{ W} \quad (57)$$

The efficiency can now be estimated as:

$$\eta = \frac{P_{\text{OUT}}}{P_{\text{OUT}} + P_{\text{LOSS}}} = \frac{6.6 \text{ W}}{6.6 \text{ W} + 1.499 \text{ W}} = 81 \% \quad (58)$$

With this information we can estimate the junction temperature of the LMR12015/20.

8.2.1.10.9 Calculating the LMR2015/20 Junction Temperature

Thermal Definitions:

T_{J} = IC junction temperature

T_{A} = Ambient temperature

$R_{\theta\text{JC}}$ = Thermal resistance from IC junction to device case

$R_{\theta\text{JA}}$ = Thermal resistance from IC junction to ambient air

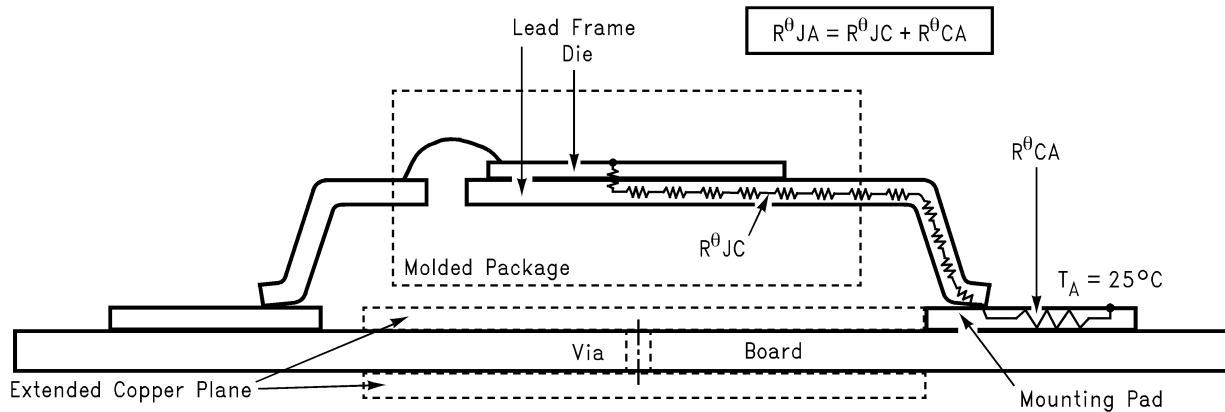

Figure 30. Cross-Sectional View Of Integrated Circuit Mounted On A Printed Circuit Board.

Heat in the LMR12015/20 due to internal power dissipation is removed through conduction and/or convection.

Conduction: Heat transfer occurs through cross sectional areas of material. Depending on the material, the transfer of heat can be considered to have poor to good thermal conductivity properties (insulator vs conductor).

Heat Transfer goes as:

$$\text{Silicon} \rightarrow \text{Lead Frame} \rightarrow \text{PCB} \tag{59}$$

Convection: Heat transfer is by means of airflow. This could be from a fan or natural convection. Natural convection occurs when air currents rise from the hot device to cooler air.

Thermal impedance is defined as:

$$R_{\theta} = \frac{\Delta T}{\text{Power}} \tag{60}$$

Thermal impedance from the silicon junction to the ambient air is defined as:

$$R_{\theta JA} = \frac{T_J - T_A}{\text{Power}} \tag{61}$$

This impedance can vary depending on the thermal properties of the PCB. This includes PCB size, weight of copper used to route traces, the ground plane, and the number of layers within the PCB. The type and number of thermal vias can also make a large difference in the thermal impedance. Thermal vias are necessary in most applications. They conduct heat from the surface of the PCB to the ground plane. Six to nine thermal vias should be placed under the exposed pad to the ground plane. Placing more than nine thermal vias results in only a small reduction to $R_{\theta JA}$ for the same copper area. These vias should have 8 mil holes to avoid wicking solder away from the DAP. See [AN-1187 Leadless Leadframe Package \(LLP\)](#) and [AN-1520 A Guide to Board Layout for Best Thermal Resistance for Exposed Packages](#) for more information on package thermal performance.

To predict the silicon junction temperature for a given application, three methods can be used. The first is useful before prototyping and the other two can more accurately predict the junction temperature within the application.

Method 1:

The first method predicts the junction temperature by extrapolating a best guess $R_{\theta JA}$ from the table or graph. The tables and graph are for natural convection. The internal dissipation can be calculated using the efficiency calculations. This allows the user to make a rough prediction of the junction temperature in their application. Methods two and three can later be used to determine the junction temperature more accurately.

The table below has values of $R_{\theta JA}$ for the WSON package.

Table 2. $R_{\theta JA}$ Values for the WSON at 1-Watt Dissipation:

NUMBER OF BOARD LAYERS	SIZE OF BOTTOM LAYER COPPER CONNECTED TO DAP	SIZE OF TOP LAYER COPPER CONNECTED TO DAP	NUMBER OF 8 MIL THERMAL VIAS	$R_{\theta JA}$
------------------------	--	---	------------------------------	-----------------

Table 2. $R_{\theta JA}$ Values for the WSON at 1-Watt Dissipation: (continued)

2	0.25 in ²	0.05 in ²	8	78°C/W
2	0.5625 in ²	0.05 in ²	8	65.6°C/W
2	1 in ²	0.05 in ²	8	58.6°C/W
2	1.3225 in ²	0.05 in ²	8	50°C/W
4 (Eval Board)	3.25 in ²	2.25 in ²	15	30.7°C/W

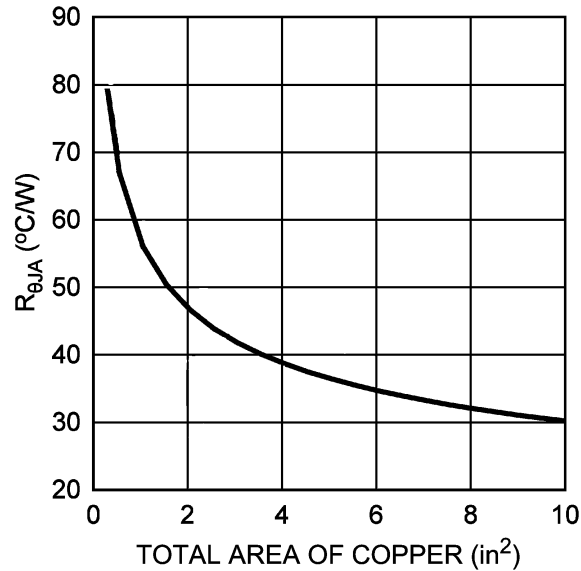

**Figure 31. Estimate of Thermal Resistance vs. Ground Copper Area
Eight Thermal Vias and Natural Convection**

Method 2:

The second method requires the user to know the thermal impedance of the silicon junction to case. ($R_{\theta JC}$) is approximately 9.1°C/W for the WSON. The case temperature should be measured on the bottom of the PCB at a thermal via directly under the DAP of the LMR12015/20. The solder resist must be removed from this area for temperature testing. The reading will be more accurate if it is taken midway between pins 2 and 9, where the NMOS switch is located. Knowing the internal dissipation from the efficiency calculation given previously, and the case temperature (T_C) we have:

$$R_{\theta JC} = \frac{T_J - T_C}{\text{Power}} \tag{62}$$

Therefore:

$$T_J = (R_{\theta JC} \times P_{\text{Loss}}) + T_C \tag{63}$$

8.2.2 Application Curves

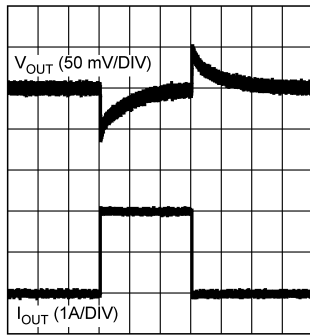

100 μ s/DIV
 $V_{OUT} = 5\text{ V}$ $I_{OUT} = 100\text{ mA} - 2\text{ A}$ at Slew Rate = $2\text{ A} / \mu\text{s}$

Refer To [Figure 37](#)

Figure 32. Load Transient

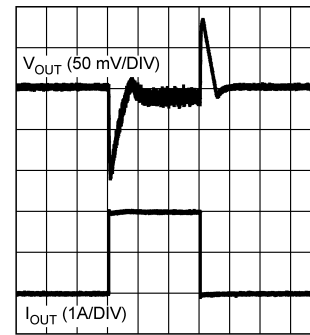

100 μ s/DIV
 $V_{OUT} = 3.3\text{ V}$ $I_{OUT} = 100\text{ mA} - 2\text{ A}$ at Slew Rate = $2\text{ A} / \mu\text{s}$

Refer To [Figure 39](#)

Figure 33. Load Transient

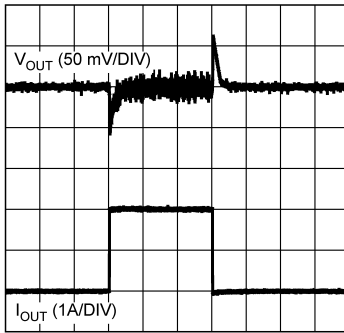

100 μ s/DIV
 $V_{OUT} = 1.8\text{ V}$ $I_{OUT} = 100\text{ mA} - 2\text{ A}$ at Slew Rate = $2\text{ A} / \mu\text{s}$

Refer To [Figure 40](#)

Figure 34. Load Transient

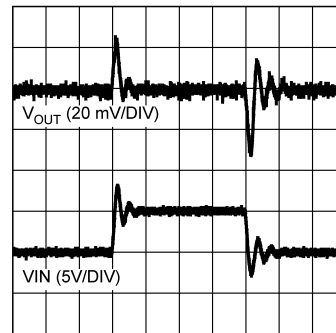

100 μ s/DIV
 $V_{IN} = 10\text{ to }15\text{ V}$ $V_{OUT} = 3.3\text{ V}$ No C_{FF}

Refer To [Figure 39](#)

Figure 35. Line Transient

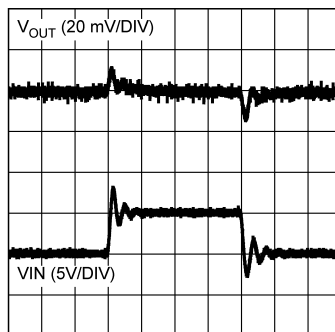

100 μ s/DIV
 $V_{IN} = 10\text{ to }15\text{ V}$ $V_{OUT} = 3.3\text{ V}$ No C_{FF}

Refer To [Figure 38](#)

Figure 36. Line Transient

8.2.3 LMR12015/20 Circuit Examples

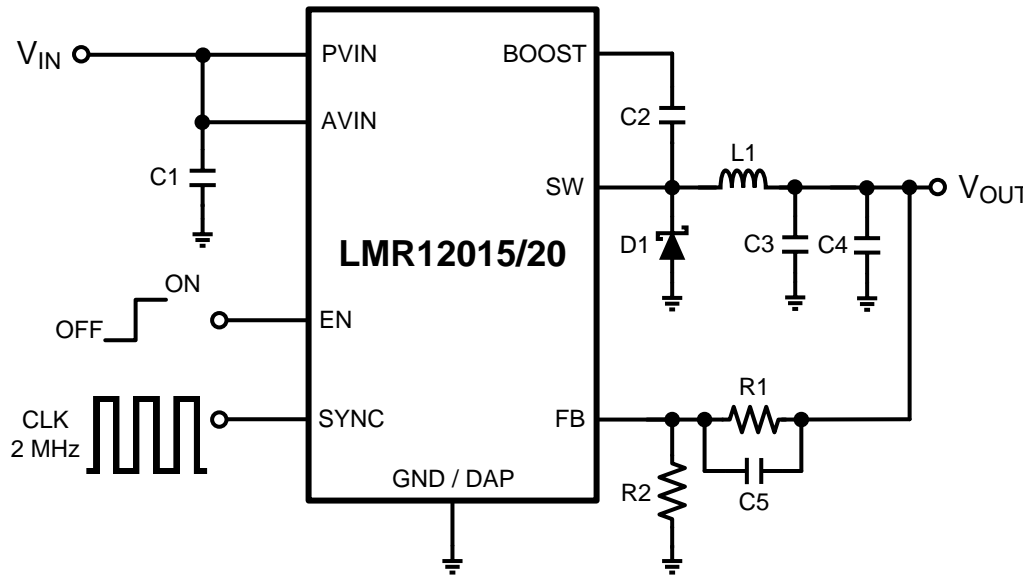

Figure 37. $V_{IN} = 7 - 20\text{ V}$, $V_{OUT} = 5\text{ V}$, $f_{SW} = 2\text{ MHz}$,
 $I_{OUT} = \text{Full Load With } C_{FF}$

Table 3. Bill Of Materials For Figure 37

PART NAME	PART ID	PART VALUE	PART NUMBER	MANUFACTURER
Buck Regulator	U1	1.5 or 2A Buck Regulator	LMR12015/20	Texas Instruments
C_{PVIN}	C1	10 μF	C1210C106K8PACTU	Kemet
C_{BOOST}	C2	0.1 μF	C0603X104K4RACTU	Kemet
C_{OUT}	C3	22 μF	GRM32ER71C226KE18L	MuRata
C_{OUT}	C4	22 μF	GRM32ER71C226KE18L	MuRata
C_{FF}	C5	0.18 μF	0603ZC184KAT2A	AVX
Catch Diode	D1	Schottky Diode $V_f = 0.32\text{V}$	CMS06	Toshiba
Inductor	L1	3.3 μH	7447789003	Würth
Feedback Resistor	R1	4.02 k Ω	CRCW06034K02FKEA	Vishay
Feedback Resistor	R2	1.02 k Ω	CRCW06031K02FKEA	Vishay

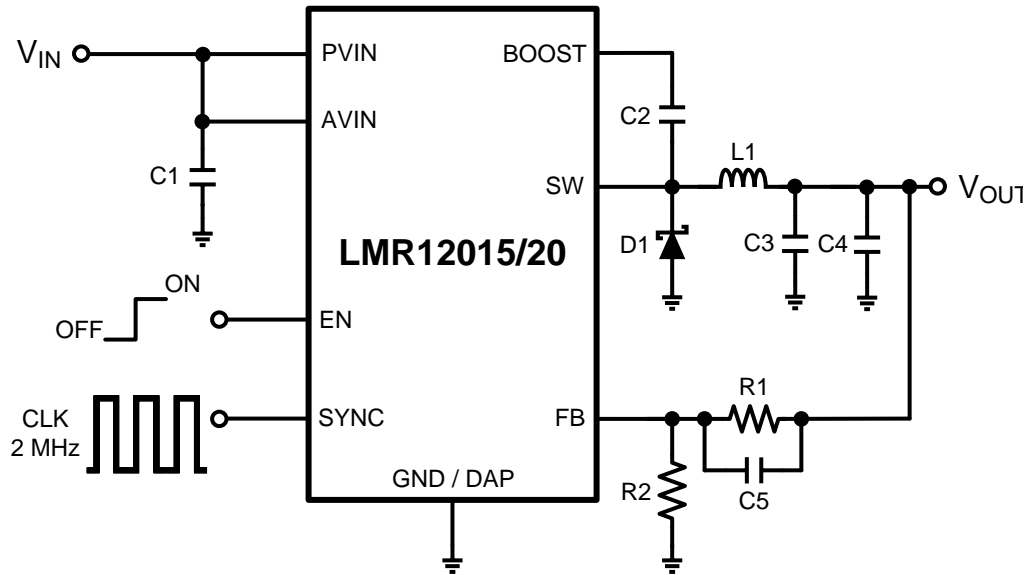

Figure 38. $V_{IN} = 5 - 20\text{ V}$, $V_{OUT} = 3.3\text{ V}$, $f_{SW} = 2\text{ MHz}$,
 $I_{OUT} = \text{Full Load With } C_{FF}$

Table 4. Bill Of Materials For Figure 38

PART NAME	PART ID	PART VALUE	PART NUMBER	MANUFACTURER
Buck Regulator	U1	1.5 or 2A Buck Regulator	LMR12015/20	Texas Instruments
C_{PVIN}	C1	10 μF	C1210C106K8PACTU	Kemet
C_{BOOST}	C2	0.1 μF	C0603X104K4RACTU	Kemet
C_{OUT}	C3	22 μF	GRM32ER71C226KE18L	MuRata
C_{OUT}	C4	22 μF	GRM32ER71C226KE18L	MuRata
C_{FF}	C5	0.18 μF	0603ZC184KAT2A	AVX
Catch Diode	D1	Schottky Diode $V_f = 0.32\text{V}$	CMS06	Toshiba
Inductor	L1	3.3 μH	7447789003	Würth
Feedback Resistor	R1	2.32 $\text{k}\Omega$	CRCW06032K32FKEA	Vishay
Feedback Resistor	R2	1.02 $\text{k}\Omega$	CRCW06031K02FKEA	Vishay

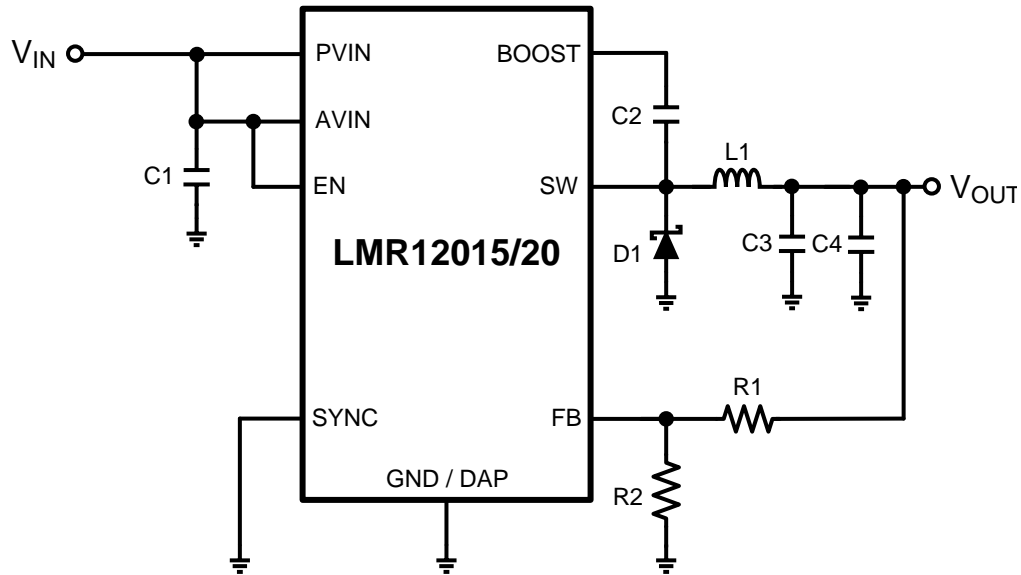

Figure 39. $V_{IN} = 5 - 20\text{ V}$, $V_{OUT} = 3.3\text{ V}$, $f_{SW} = 2\text{ MHz}$,
 $I_{OUT} = \text{Full Load Without } C_{FF}$

Table 5. Bill Of Materials For Figure 39

PART NAME	PART ID	PART VALUE	PART NUMBER	MANUFACTURER
Buck Regulator	U1	1.5 or 2A Buck Regulator	LMR12015/20	Texas Instruments
C_{PVIN}	C1	10 μF	C1210C106K8PACTU	Kemet
C_{BOOST}	C2	0.1 μF	C0603X104K4RACTU	Kemet
C_{OUT}	C3	22 μF	GRM32ER71C226KE18L	MuRata
C_{OUT}	C4	22 μF	GRM32ER71C226KE18L	MuRata
Catch Diode	D1	Schottky Diode $V_f = 0.32\text{V}$	CMS06	Toshiba
Inductor	L1	3.3 μH	7447789003	Sumida
Feedback Resistor	R1	2.32 $\text{k}\Omega$	CRCW06032K32FKEA	Vishay
Feedback Resistor	R2	1.02 $\text{k}\Omega$	CRCW06031K02FKEA	Vishay

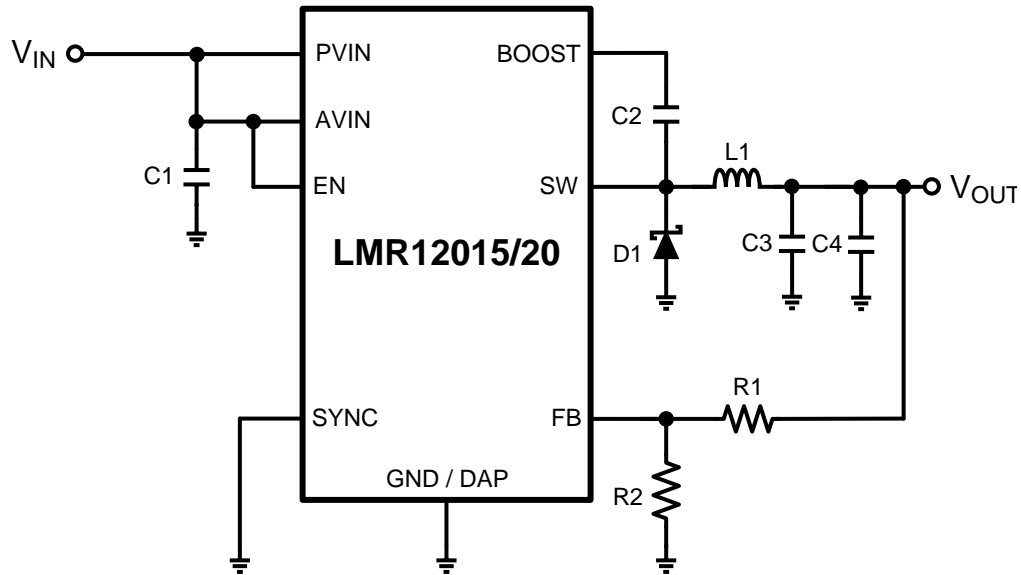

Figure 40. $V_{IN} = 3.3 - 16\text{ V}$, $V_{OUT} = 1.8\text{ V}$, $f_{SW} = 2\text{ MHz}$, $I_{OUT} = \text{Full Load}$

Table 6. Bill Of Materials For Figure 40

PART NAME	PART ID	PART VALUE	PART NUMBER	MANUFACTURER
Buck Regulator	U1	1.5 or 2A Buck Regulator	LMR12015/20	Texas Instruments
C_{PVIN}	C1	10 μF	GRM32DR71E106KA12L	Murata
C_{BOOST}	C2	0.1 μF	GRM188R71C104KA01D	Murata
C_{OUT}	C3	22 μF	C3225X7R1C226K	TDK
C_{OUT}	C4	22 μF	C3225X7R1C226K	TDK
Catch Diode	D1	Schottky Diode $V_f = 0.32\text{V}$	CMS06	Toshiba
Inductor	L1	1.0 μH	CDRH5D18BHPNP	Sumida
Feedback Resistor	R1	12 $\text{k}\Omega$	CRCW060312K0FKEA	Vishay
Feedback Resistor	R2	15 $\text{k}\Omega$	CRCW060315K0FKEA	Vishay

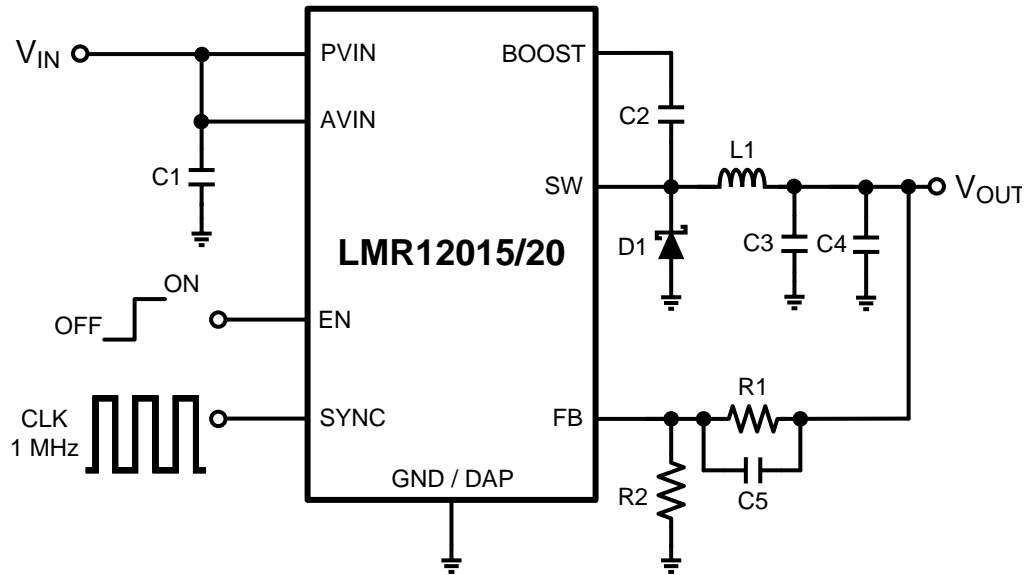

Figure 41. $V_{IN} = 3.3 - 16\text{ V}$, $V_{OUT} = 1.8\text{ V}$, $f_{SW} = 1\text{ MHz}$, $I_{OUT} = \text{Full Load}$

Table 7. Bill Of Materials For Figure 41

PART NAME	PART ID	PART VALUE	PART NUMBER	MANUFACTURER
Buck Regulator	U1	1.5 or 2A Buck Regulator	LMR12015/20	Texas Instruments
C_{PVIN}	C1	10 μF	GRM32DR71E106KA12L	Murata
C_{BOOST}	C2	0.1 μF	GRM188R71C104KA01D	Murata
C_{OUT}	C3	22 μF	C3225X7R1C226K	TDK
C_{OUT}	C4	22 μF	C3225X7R1C226K	TDK
C_{FF}	C5	3.9 nF	GRM188R71H392KA01D	Murata
Catch Diode	D1	Schottky Diode $V_f = 0.32\text{V}$	CMS06	Toshiba
Inductor	L1	1.8 μH	CDRH5D18BHPNP	Sumida
Feedback Resistor	R1	12 k Ω	CRCW060312K0FKEA	Vishay
Feedback Resistor	R2	15 k Ω	CRCW060315K0FKEA	Vishay

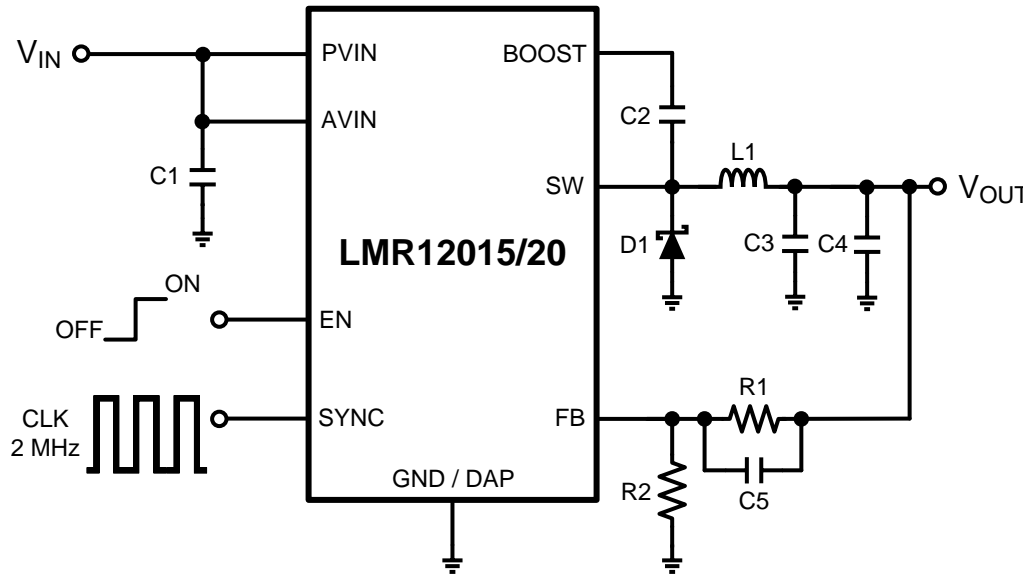

Figure 42. $V_{IN} = 3.3 - 9\text{ V}$, $V_{OUT} = 1.2\text{ V}$, $f_{SW} = 2\text{ MHz}$, $I_{OUT} = \text{Full Load}$

Table 8. Bill Of Materials For Figure 42

PART NAME	PART ID	PART VALUE	PART NUMBER	MANUFACTURER
Buck Regulator	U1	1.5 or 2A Buck Regulator	LMR12015/20	Texas Instruments
C_{PVIN}	C1	10 μF	GRM32DR71E106KA12L	Murata
C_{BOOST}	C2	0.1 μF	GRM188R71C104KA01D	Murata
C_{OUT}	C3	47 μF	GRM32ER61A476KE20L	Murata
C_{OUT}	C4	22 μF	C3225X7R1C226K	TDK
C_{FF}	C5	NOT MOUNTED		
Catch Diode	D1	Schottky Diode $V_f = 0.32\text{V}$	CMS06	Toshiba
Inductor	L1	0.56 μH	CDRH2D18/HPNP	Sumida
Feedback Resistor	R1	1.02 $\text{k}\Omega$	CRCW06031K02FKEA	Vishay
Feedback Resistor	R2	5.10 $\text{k}\Omega$	CRCW06035K10FKEA	Vishay

9 Layout

9.1 Layout Considerations

9.1.1 Compact Layout

The performance of any switching converter depends as much upon the layout of the PCB as the component selection. The following guidelines will help the user design a circuit with maximum rejection of outside EMI and minimum generation of unwanted EMI.

Parasitic inductance can be reduced by keeping the power path components close together and keeping the area of the loops small, on which high currents travel. Short, thick traces or copper pours (shapes) are best. In particular, the switch node (where L1, D1, and the SW pin connect) should be just large enough to connect all three components without excessive heating from the current it carries. The LMR12015/20 operates in two distinct cycles (see Figure 22) whose high current paths are shown below in Figure 43:

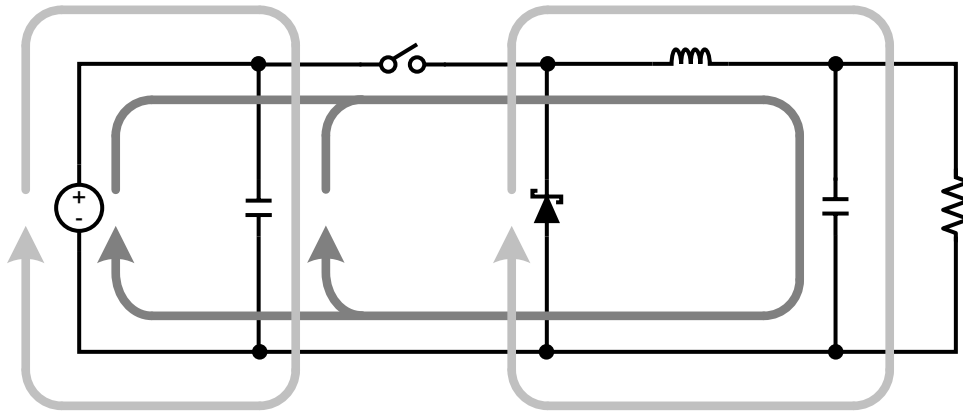

Figure 43. Buck Converter Current Loops

The dark grey, inner loop represents the high current path during the MOSFET on-time. The light grey, outer loop represents the high current path during the off-time.

9.1.2 Ground Plane and Shape Routing

The diagram of Figure 43 is also useful for analyzing the flow of continuous current vs. the flow of pulsating currents. The circuit paths with current flow during both the on-time and off-time are considered to be continuous current, while those that carry current during the on-time or off-time only are pulsating currents. Preference in routing should be given to the pulsating current paths, as these are the portions of the circuit most likely to emit EMI. The ground plane of a PCB is a conductor and return path, and it is susceptible to noise injection just like any other circuit path. The path between the input source and the input capacitor and the path between the catch diode and the load are examples of continuous current paths. In contrast, the path between the catch diode and the input capacitor carries a large pulsating current. This path should be routed with a short, thick shape, preferably on the component side of the PCB. Multiple vias in parallel should be used right at the pad of the input capacitor to connect the component side shapes to the ground plane. A second pulsating current loop that is often ignored is the gate drive loop formed by the SW and BOOST pins and boost capacitor C_{BOOST} . To minimize this loop and the EMI it generates, keep C_{BOOST} close to the SW and BOOST pins.

9.1.3 FB Loop

The FB pin is a high-impedance input, and the loop created by R2, the FB pin and ground should be made as small as possible to maximize noise rejection. R2 should therefore be placed as close as possible to the FB and GND pins of the IC.

9.1.4 PCB Summary

1. Minimize the parasitic inductance by keeping the power path components close together and keeping the area of the high-current loops small.

Layout Considerations (continued)

2. The most important consideration when completing the layout is the close coupling of the GND connections of the C_{IN} capacitor and the catch diode D1. These ground connections must be immediately adjacent, with multiple vias in parallel at the pad of the input capacitor connected to GND. Place C_{IN} and D1 as close to the IC as possible.
3. Next in importance is the location of the GND connection of the C_{OUT} capacitor, which should be near the GND connections of C_{IN} and D1.
4. There should be a continuous ground plane on the copper layer directly beneath the converter. This reduces parasitic inductance and EMI.
5. The FB pin is a high impedance node — take care to make the FB trace short to avoid noise pickup and inaccurate regulation. Place the feedback resistors as close as possible to the IC, with the GND of R2 placed as close as possible to the GND of the IC. The V_{OUT} trace to R1 should be routed away from the inductor and any other traces that are switching.
6. High AC currents flow through the V_{IN} , SW and V_{OUT} traces, so they must be as short and wide as possible. However, making the traces wide increases radiated noise, so the layout designer must make this trade-off. Radiated noise can be decreased by choosing a shielded inductor.

Place the remaining components as close as possible to the IC. See [AN-2279 LMR12020 Evaluation Module](#) for further considerations and the LMR12015/20 eval board as an example of a four-layer layout.

10 器件和文档支持

10.1 器件支持

10.1.1 第三方产品免责声明

TI 发布的与第三方产品或服务有关的信息，不能构成与此类产品或服务或保修的适用性有关的认可，不能构成此类产品或服务单独或与任何 TI 产品或服务一起的表示或认可。

10.1.2 开发支持

10.1.2.1 使用 **WEBENCH®** 工具创建定制设计

单击[此处](#)，使用 LMR12015 器件并借助 WEBENCH® 电源设计器创建定制设计方案。

1. 首先输入输入电压 (V_{IN})、输出电压 (V_{OUT}) 和输出电流 (I_{OUT}) 要求。
2. 使用优化器拨盘优化该设计的关键参数，如效率、尺寸和成本。
3. 将生成的设计与德州仪器 (TI) 的其他可行的解决方案进行比较。

WEBENCH 电源设计器可提供定制原理图以及罗列实时价格和组件供货情况的物料清单。

在多数情况下，可执行以下操作：

- 运行电气仿真，观察重要波形以及电路性能
- 运行热性能仿真，了解电路板热性能
- 将定制原理图和布局方案以常用 CAD 格式导出
- 打印设计方案的 PDF 报告并与同事共享

有关 WEBENCH 工具的详细信息，请访问 www.ti.com.cn/WEBENCH。

10.2 相关链接

表 9 列出了快速访问链接。类别包括技术文档、支持和社区资源、工具与软件，以及立即订购快速访问。

表 9. 相关链接

器件	产品文件夹	立即订购	技术文档	工具与软件	支持和社区
LMR12015	单击此处	单击此处	单击此处	单击此处	单击此处
LMR12020	单击此处	单击此处	单击此处	单击此处	单击此处

10.3 接收文档更新通知

要接收文档更新通知，请导航至 TI.com.cn 上的器件产品文件夹。单击右上角的 *通知我* 进行注册，即可每周接收产品信息更改摘要。有关更改的详细信息，请查看任何已修订文档中包含的修订历史记录。

10.4 社区资源

The following links connect to TI community resources. Linked contents are provided "AS IS" by the respective contributors. They do not constitute TI specifications and do not necessarily reflect TI's views; see TI's [Terms of Use](#).

TI E2E™ Online Community *TI's Engineer-to-Engineer (E2E) Community*. Created to foster collaboration among engineers. At e2e.ti.com, you can ask questions, share knowledge, explore ideas and help solve problems with fellow engineers.

Design Support *TI's Design Support* Quickly find helpful E2E forums along with design support tools and contact information for technical support.

10.5 商标

E2E is a trademark of Texas Instruments.

WEBENCH is a registered trademark of Texas Instruments.

All other trademarks are the property of their respective owners.

10.6 静电放电警告



ESD 可能会损坏该集成电路。德州仪器 (TI) 建议通过适当的预防措施处理所有集成电路。如果不遵守正确的处理措施和安装程序，可能会损坏集成电路。

ESD 的损坏小至导致微小的性能降级，大至整个器件故障。精密的集成电路可能更容易受到损坏，这是因为非常细微的参数更改都可能会导致器件与其发布的规格不相符。

10.7 Glossary

[SLYZ022](#) — *TI Glossary*.

This glossary lists and explains terms, acronyms, and definitions.

11 机械、封装和可订购信息

以下页面包含机械、封装和可订购信息。这些信息是指定器件的最新可用数据。数据如有变更，恕不另行通知，且不会对此文档进行修订。如需获取此数据表的浏览器版本，请查阅左侧的导航栏。

PACKAGING INFORMATION

Orderable Device	Status (1)	Package Type	Package Drawing	Pins	Package Qty	Eco Plan (2)	Lead finish/ Ball material (6)	MSL Peak Temp (3)	Op Temp (°C)	Device Marking (4/5)	Samples
LMR12015XSD/NOPB	ACTIVE	WSON	DSC	10	1000	RoHS & Green	SN	Level-1-260C-UNLIM	-40 to 125	L285B	Samples
LMR12015XSDX/NOPB	ACTIVE	WSON	DSC	10	4500	RoHS & Green	SN	Level-1-260C-UNLIM	-40 to 125	L285B	Samples
LMR12020XSD/NOPB	ACTIVE	WSON	DSC	10	1000	RoHS & Green	SN	Level-1-260C-UNLIM	-40 to 125	L284B	Samples
LMR12020XSDX/NOPB	ACTIVE	WSON	DSC	10	4500	RoHS & Green	SN	Level-1-260C-UNLIM	-40 to 125	L284B	Samples

(1) The marketing status values are defined as follows:

ACTIVE: Product device recommended for new designs.

LIFEBUY: TI has announced that the device will be discontinued, and a lifetime-buy period is in effect.

NRND: Not recommended for new designs. Device is in production to support existing customers, but TI does not recommend using this part in a new design.

PREVIEW: Device has been announced but is not in production. Samples may or may not be available.

OBSOLETE: TI has discontinued the production of the device.

(2) **RoHS:** TI defines "RoHS" to mean semiconductor products that are compliant with the current EU RoHS requirements for all 10 RoHS substances, including the requirement that RoHS substance do not exceed 0.1% by weight in homogeneous materials. Where designed to be soldered at high temperatures, "RoHS" products are suitable for use in specified lead-free processes. TI may reference these types of products as "Pb-Free".

RoHS Exempt: TI defines "RoHS Exempt" to mean products that contain lead but are compliant with EU RoHS pursuant to a specific EU RoHS exemption.

Green: TI defines "Green" to mean the content of Chlorine (Cl) and Bromine (Br) based flame retardants meet JS709B low halogen requirements of <=1000ppm threshold. Antimony trioxide based flame retardants must also meet the <=1000ppm threshold requirement.

(3) **MSL, Peak Temp.** - The Moisture Sensitivity Level rating according to the JEDEC industry standard classifications, and peak solder temperature.

(4) There may be additional marking, which relates to the logo, the lot trace code information, or the environmental category on the device.

(5) Multiple Device Markings will be inside parentheses. Only one Device Marking contained in parentheses and separated by a "-" will appear on a device. If a line is indented then it is a continuation of the previous line and the two combined represent the entire Device Marking for that device.

(6) **Lead finish/Ball material** - Orderable Devices may have multiple material finish options. Finish options are separated by a vertical ruled line. Lead finish/Ball material values may wrap to two lines if the finish value exceeds the maximum column width.

Important Information and Disclaimer:The information provided on this page represents TI's knowledge and belief as of the date that it is provided. TI bases its knowledge and belief on information provided by third parties, and makes no representation or warranty as to the accuracy of such information. Efforts are underway to better integrate information from third parties. TI has taken and

continues to take reasonable steps to provide representative and accurate information but may not have conducted destructive testing or chemical analysis on incoming materials and chemicals. TI and TI suppliers consider certain information to be proprietary, and thus CAS numbers and other limited information may not be available for release.

In no event shall TI's liability arising out of such information exceed the total purchase price of the TI part(s) at issue in this document sold by TI to Customer on an annual basis.

TAPE AND REEL INFORMATION

QUADRANT ASSIGNMENTS FOR PIN 1 ORIENTATION IN TAPE

*All dimensions are nominal

Device	Package Type	Package Drawing	Pins	SPQ	Reel Diameter (mm)	Reel Width W1 (mm)	A0 (mm)	B0 (mm)	K0 (mm)	P1 (mm)	W (mm)	Pin1 Quadrant
LMR12015XSD/NOPB	WSON	DSC	10	1000	178.0	12.4	3.3	3.3	1.0	8.0	12.0	Q1
LMR12015XSDX/NOPB	WSON	DSC	10	4500	330.0	12.4	3.3	3.3	1.0	8.0	12.0	Q1
LMR12020XSD/NOPB	WSON	DSC	10	1000	178.0	12.4	3.3	3.3	1.0	8.0	12.0	Q1
LMR12020XSDX/NOPB	WSON	DSC	10	4500	330.0	12.4	3.3	3.3	1.0	8.0	12.0	Q1

TAPE AND REEL BOX DIMENSIONS

*All dimensions are nominal

Device	Package Type	Package Drawing	Pins	SPQ	Length (mm)	Width (mm)	Height (mm)
LMR12015XSD/NOPB	WSON	DSC	10	1000	208.0	191.0	35.0
LMR12015XSDX/NOPB	WSON	DSC	10	4500	367.0	367.0	35.0
LMR12020XSD/NOPB	WSON	DSC	10	1000	208.0	191.0	35.0
LMR12020XSDX/NOPB	WSON	DSC	10	4500	367.0	367.0	35.0

DSC0010B

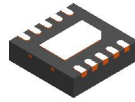

PACKAGE OUTLINE

WSON - 0.8 mm max height

PLASTIC SMALL OUTLINE - NO LEAD

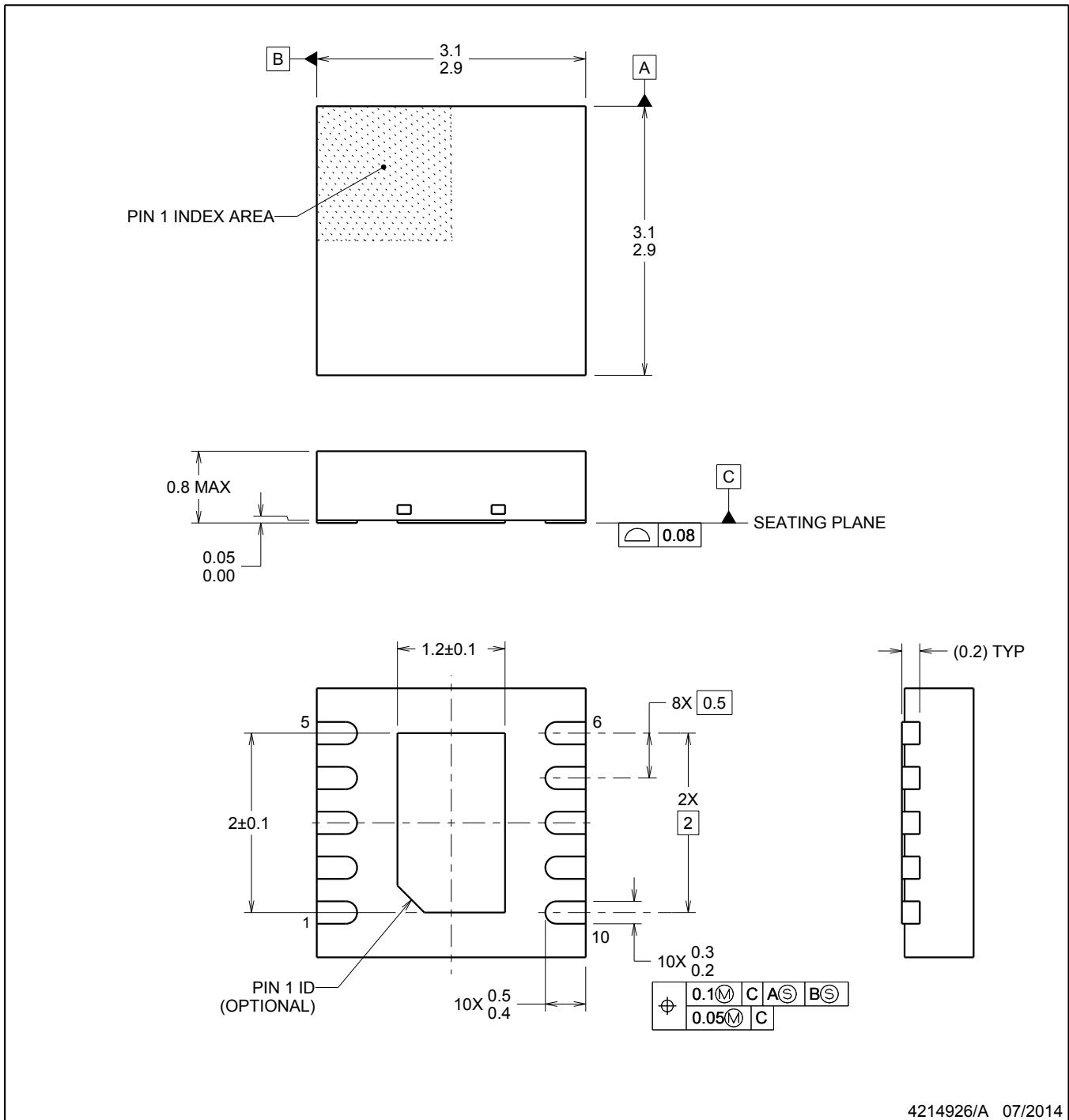

NOTES:

1. All linear dimensions are in millimeters. Any dimensions in parenthesis are for reference only. Dimensioning and tolerancing per ASME Y14.5M.
2. This drawing is subject to change without notice.
3. The package thermal pad must be soldered to the printed circuit board for thermal and mechanical performance.

EXAMPLE BOARD LAYOUT

DSC0010B

WSON - 0.8 mm max height

PLASTIC SMALL OUTLINE - NO LEAD

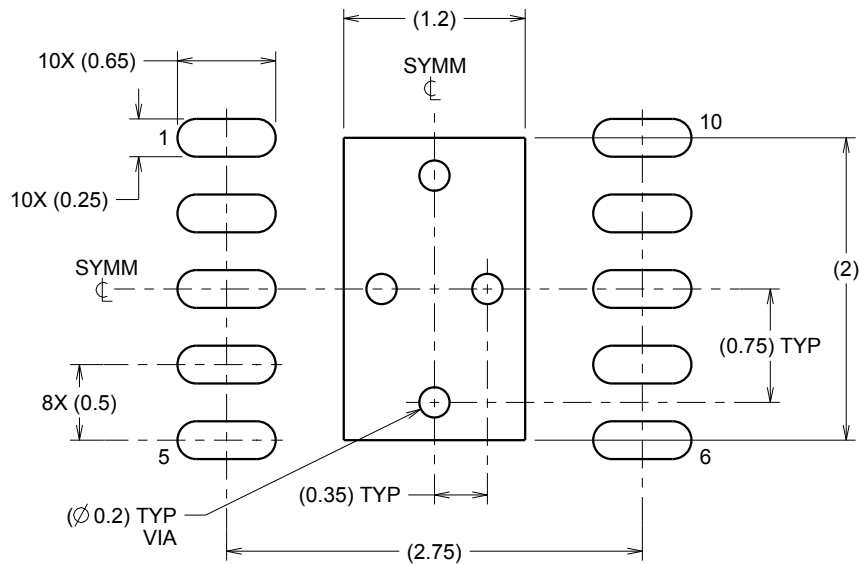

LAND PATTERN EXAMPLE
SCALE:20X

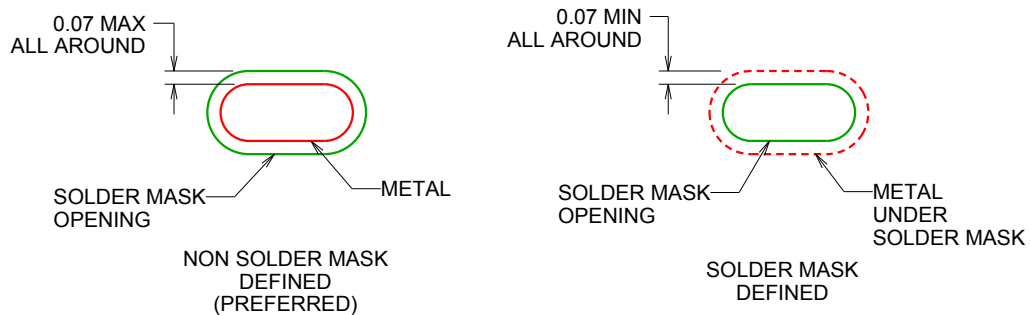

SOLDER MASK DETAILS

4214926/A 07/2014

NOTES: (continued)

4. This package is designed to be soldered to a thermal pad on the board. For more information, see Texas Instruments literature number SLUA271 (www.ti.com/lit/slua271).

重要声明和免责声明

TI“按原样”提供技术和可靠性数据（包括数据表）、设计资源（包括参考设计）、应用或其他设计建议、网络工具、安全信息和其他资源，不保证没有瑕疵且不做任何明示或暗示的担保，包括但不限于对适销性、某特定用途方面的适用性或不侵犯任何第三方知识产权的暗示担保。

这些资源可供使用 TI 产品进行设计的熟练开发人员使用。您将自行承担以下全部责任：(1) 针对您的应用选择合适的 TI 产品，(2) 设计、验证并测试您的应用，(3) 确保您的应用满足相应标准以及任何其他功能安全、信息安全、监管或其他要求。

这些资源如有变更，恕不另行通知。TI 授权您仅可将这些资源用于研发本资源所述的 TI 产品的应用。严禁对这些资源进行其他复制或展示。您无权使用任何其他 TI 知识产权或任何第三方知识产权。您应全额赔偿因在这些资源的使用中对 TI 及其代表造成的任何索赔、损害、成本、损失和债务，TI 对此概不负责。

TI 提供的产品受 [TI 的销售条款](#) 或 [ti.com](#) 上其他适用条款/TI 产品随附的其他适用条款的约束。TI 提供这些资源并不会扩展或以其他方式更改 TI 针对 TI 产品发布的适用的担保或担保免责声明。

TI 反对并拒绝您可能提出的任何其他或不同的条款。

邮寄地址：Texas Instruments, Post Office Box 655303, Dallas, Texas 75265
Copyright © 2021，德州仪器 (TI) 公司