

BQ2946xx Single-Cell Protector for Li-Ion Batteries

1 Features

- Single-Cell Overvoltage Monitor for Secondary Protection
- Fixed Programmable Delay Timer
- Fixed Overvoltage Protection (OVP) Threshold
 - Available Range of 3.85 V to 4.6 V
- Fixed OVP Delay Option: 4 s or 6.5 s
- High-Accuracy OVP:
 - ± 10 mV
- Low Power Consumption $I_{CC} \approx 1 \mu\text{A}$ ($V_{\text{CELL(ALL)}} < V_{\text{PROTECT}}$)
- Low Leakage Current per Cell Input < 100 nA
- Small Package Footprint
 - 6-Pin SON

2 Applications

- Second-level protection in Li-ion battery packs in:
 - [Tablets](#)
 - [Slates](#)
 - [Portable equipment and instrumentation](#)

3 Description

The BQ2946xx family of products is a secondary-level overvoltage monitor and protector for Li-Ion battery pack systems. The cell is monitored for overvoltage condition and triggers an internal counter once the OVP threshold is exceeded; after a fixed set delay, the out is transitioned to a high level. The output is reset (goes low) if the cell voltage drops below the set threshold minus the hysteresis.

Device Information

PART NUMBER ⁽¹⁾	PACKAGE	BODY SIZE (NOM)
BQ294602	SON (6)	2.00 mm × 2.00 mm
BQ294604		
BQ294624		
BQ294682		

- (1) For all available packages, see the orderable addendum at the end of the data sheet.

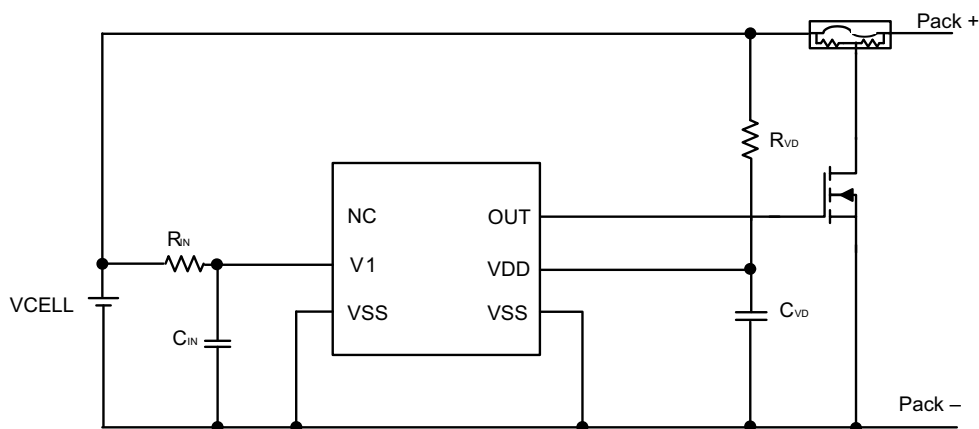

Simplified Schematic



Table of Contents

1 Features	1	8.1 Overview.....	7
2 Applications	1	8.2 Functional Block Diagram.....	7
3 Description	1	8.3 Feature Description.....	7
4 Revision History	2	8.4 Device Functional Modes.....	8
5 Device Options	3	9 Layout	12
6 Pin Configuration and Functions	3	9.1 Layout Guidelines.....	12
7 Specifications	4	9.2 Layout Example.....	12
7.1 Absolute Maximum Ratings.....	4	10 Device and Documentation Support	13
7.2 ESD Ratings.....	4	10.1 Third-Party Products Disclaimer.....	13
7.3 Recommended Operating Conditions.....	4	10.2 Receiving Notification of Documentation Updates..	13
7.4 Thermal Information.....	4	10.3 Support Resources.....	13
7.5 Electrical Characteristics.....	5	10.4 Trademarks.....	13
7.6 Typical Characteristics.....	6	10.5 Electrostatic Discharge Caution.....	13
8 Detailed Description	7	10.6 Glossary.....	13

4 Revision History

NOTE: Page numbers for previous revisions may differ from page numbers in the current version.

Changes from Revision D (April 2017) to Revision E (April 2021)	Page
• Removed PRODUCT PREVIEW devices	3

Changes from Revision C (July 2015) to Revision D (April 2017)	Page
• Added BQ294624 in <i>Device Information</i>	1
• Added <i>Receiving Notification of Documentation Updates</i> section.....	13

5 Device Options

T _A	PART NUMBER	OVP (V)	DELAY TIME (s)
-40°C to +110°C	BQ294602	4.35	4
	BQ294604	4.35	6.5
	BQ294624	4.45	6.5
	BQ294682	4.225	4

6 Pin Configuration and Functions

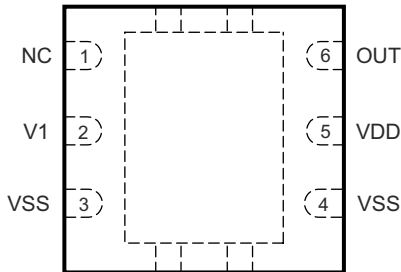

Figure 6-1. DRV Package 6-Pin SON Top View

Table 6-1. Pin Functions

PIN		I/O	DESCRIPTION
NAME	NO.		
NC	1	—	No connection
OUT	6	OA	Output drive for external N-channel FET.
PWRPAD	Thermal Pad	—	VSS pin to be connected to the PWRPAD on the printed-circuit-board (PCB) for proper operation.
V1	2	IA	Sense input for positive voltage of the cell.
VSS	3	P	Electrically connected to IC ground and negative terminal of the cell.
VSS	4	P	Electrically connected to IC ground and negative terminal of the cell.
VDD	5	P	Power supply

7 Specifications

7.1 Absolute Maximum Ratings

over operating free-air temperature range (unless otherwise noted)⁽¹⁾

		MIN	MAX	UNIT
Supply voltage	VDD–VSS	–0.3	30	V
Input voltage	V1–VSS	–0.3	8	V
Output voltage	OUT–VSS	–0.3	30	V
Continuous total power dissipation, P _{TOT}		See Section 7.4		
Functional temperature		–65	110	°C
Lead temperature (soldering, 10 s), T _{SOLDER}			300	°C
Storage temperature, T _{stg}		–65	150	°C

- (1) Stresses beyond those listed under *Absolute Maximum Ratings* may cause permanent damage to the device. These are stress ratings only, which do not imply functional operation of the device at these or any other conditions beyond those indicated under *Recommended Operating Conditions*. Exposure to absolute-maximum-rated conditions for extended periods may affect device reliability.

7.2 ESD Ratings

		VALUE	UNIT
V _(ESD)	Electrostatic discharge	Human body model (HBM), per ANSI/ESDA/JEDEC JS-001 ⁽¹⁾	±2000
		Charged device model (CDM), per JEDEC specification JESD22-C101 ⁽²⁾	±500

- (1) JEDEC document JEP155 states that 500-V HBM allows safe manufacturing with a standard ESD control process.
 (2) JEDEC document JEP157 states that 250-V CDM allows safe manufacturing with a standard ESD control process.

7.3 Recommended Operating Conditions

over operating free-air temperature range (unless otherwise noted)

		MIN	MAX	UNIT
Supply voltage, V _{DD}	⁽¹⁾	3	8	V
Input voltage	V1–VSS	0	5	V
Operating ambient temperature, T _A		–40	110	°C

- (1) See [Section 9.2](#).

7.4 Thermal Information

THERMAL METRIC ⁽¹⁾		BQ2946xx	UNIT
		DRV (SON)	
		6 PINS	
R _{θJA}	Junction-to-ambient thermal resistance	186.4	°C/W
R _{θJC(top)}	Junction-to-case(top) thermal resistance	90.4	°C/W
R _{θJB}	Junction-to-board thermal resistance	110.7	°C/W
Ψ _{JT}	Junction-to-top characterization parameter	96.7	°C/W
Ψ _{JB}	Junction-to-board characterization parameter	90	°C/W
R _{θJC(bot)}	Junction-to-case(bottom) thermal resistance	n/a	°C/W

- (1) For more information about traditional and new thermal metrics, see the [Semiconductor and IC Package Thermal Metrics](#) application report.

7.5 Electrical Characteristics

Typical values stated where $T_A = 25^\circ\text{C}$ and $V_{DD} = 4\text{ V}$, MIN/MAX values stated where $T_A = -40^\circ\text{C}$ to $+110^\circ\text{C}$ and $V_{DD} = 4\text{ V}$ (unless otherwise noted)

TEST NO.	PARAMETER	TEST CONDITIONS	MIN	TYP	MAX	UNIT		
VOLTAGE PROTECTION THRESHOLD VCx								
1.0	V_{OV}	$V_{(\text{PROTECT})} - \text{Overshoot Detection}$	BQ294602, fixed delay 4 s, $V1 > V_{OV}$	4.35		V		
1.1			BQ294604, fixed delay 6.5 s, $V1 > V_{OV}$	4.35				
1.2			BQ294622, fixed delay 4 s, $V1 > V_{OV}$ ⁽²⁾	4.45				
1.3			BQ294624, fixed delay 6.5 s, $V1 > V_{OV}$	4.45				
1.4			BQ294682, fixed delay 4 s, $V1 > V_{OV}$	4.225				
1.5			BQ294684, fixed delay 6.5 s, $V1 > V_{OV}$ ⁽²⁾	4.225				
1.6	V_{HYS}	Overshoot Detection Hysteresis	250	300	400	V		
1.7	V_{OA}	OV Detection Accuracy	$T_A = 25^\circ\text{C}$		-10	10	mV	
1.8	$V_{OA-DRIFT}$	OV Detection Accuracy due to Temperature	$T_A = -40^\circ\text{C}$		-40	44	mV	
		$T_A = 0^\circ\text{C}$		-20	20			
		$T_A = 60^\circ\text{C}$		-24	24			
		$T_A = 110^\circ\text{C}$		-54	54			
SUPPLY AND LEAKAGE CURRENT								
1.9	I_{CC}	Supply Current	$(V1-VSS) = 4.0\text{ V}$ (see Figure 8-3 for reference)		1	2	μA	
		$(V1-VSS) = 2.8\text{ V}$ with $T_A = -40^\circ\text{C}$ to $+60^\circ\text{C}$		1.25				
1.10	I_{IN}	Input Current at V1 Pins	Measured at $V1 = 4.0\text{ V}$ $(V1-VSS) = 4.0\text{ V}$ $T_A = 0^\circ\text{C}$ to 60°C (see Figure 8-3 for reference)		-0.1	0.1	μA	
OUTPUT DRIVE OUT								
1.11	V_{OUT}	Output Drive Voltage	$(V1-VSS) > V_{OV}$ $V_{DD} = V1$, $I_{OH} = 100\ \mu\text{A}$, $T_A = -40^\circ\text{C}$ to $+110^\circ\text{C}$		3	$V_{DD} - 0.3$	V	
1.12			$(V1-VSS) < V_{OV}$, $I_{OL} = 100\ \mu\text{A}$, $T_A = 25^\circ\text{C}$ $T_A = -40^\circ\text{C}$ to $+110^\circ\text{C}$		250	400		mV
1.13			OUT Short Circuit Current		OUT = 0 V, $(V1-VSS) > V_{OV}$		1.5	3
1.14	t_R	Output Rise Time	CL = 1 nF, $V_{OH(OUT)} = 0\text{ V}$ to 5 V ⁽¹⁾		5		μs	
1.15	Z_O	Output Impedance			2	5	k Ω	
FIXED DELAY TIMER								
1.17	t_{DELAY}	Fault Detection Delay Time	Fixed Delay, BQ2946x2		3.2	4	4.8	s
			Fixed Delay, BQ2946x4		5.2	6.5	7.8	
1.18	t_{DELAY_CTM}	Fault Detection Delay Time in Test Mode	Fixed Delay (Internal settings)		15		ms	

(1) Specified by design. Not 100% tested in production.

(2) Product Preview only.

7.6 Typical Characteristics

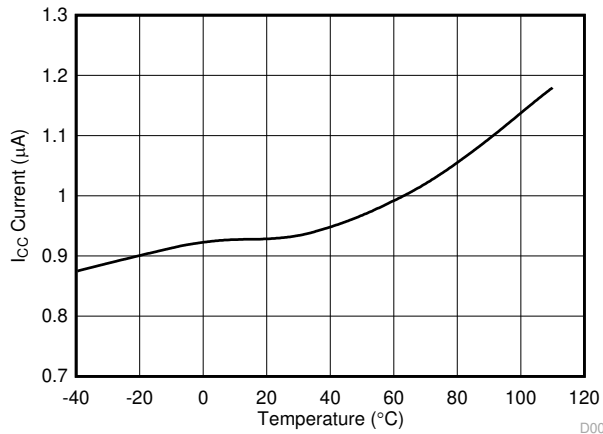

Figure 7-1. I_{CC} Current Consumption vs Temperature

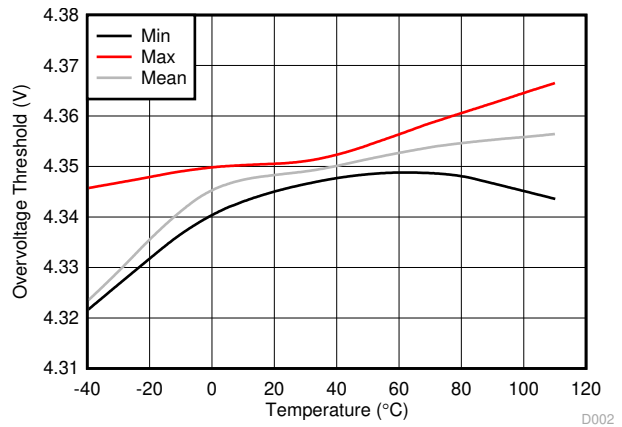

Figure 7-2. BQ294602 Overvoltage Threshold (OVT) vs Temperature

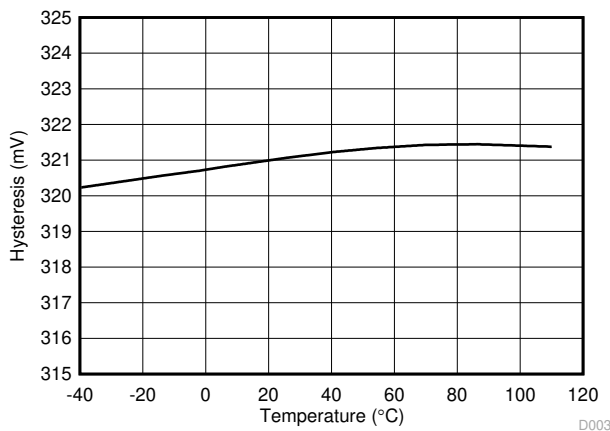

Figure 7-3. Hysteresis V_{HYS} vs Temperature

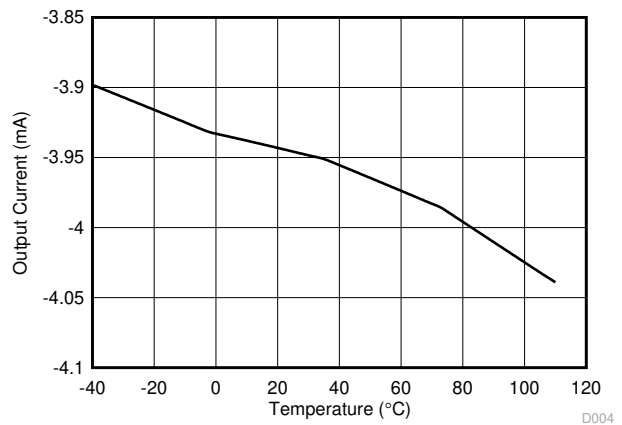

Figure 7-4. Output Current I_{OUT} vs Temperature

8 Detailed Description

8.1 Overview

The BQ2946xx is a second-level overvoltage (OV) protector for a single cell. The cell voltage is compared to a protection voltage threshold, V_{OV} . The protection threshold is preprogrammed at the factory with a range from 3.85 V to 4.65 V. When the OVP is triggered, the OUT pin goes high to activate an external N-channel FET, which conducts a low-impedance path to blow a fuse.

8.2 Functional Block Diagram

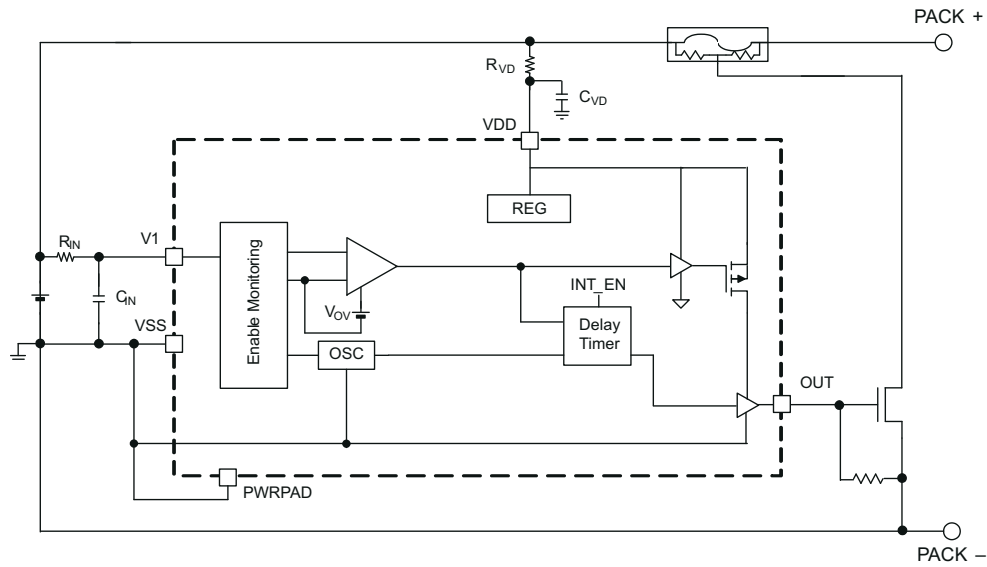

8.3 Feature Description

The method of overvoltage detection is comparing the cell voltage to an OVP threshold voltage V_{OV} . Once the cell voltage exceeds the programmed fixed value V_{OV} , the delay timer circuit is activated. This delay (t_{DELAY}) is fixed for 4 seconds for the BQ294602 device. When these conditions are satisfied, the OUT terminal is transitioned to a high level. This output (OUT) is released to a low condition if the cell input (V1) is below the OVP threshold minus the V_{HYS} .

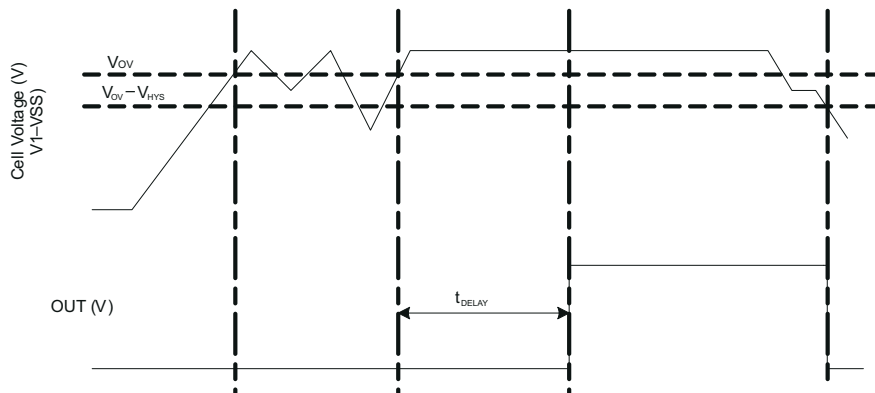

Figure 8-1. Timing for Overvoltage Sensing

8.3.1 Sense Positive Input for V1

This is an input to sense single battery cell voltage. A series resistor and a capacitor across the cell is required for noise filtering and stable voltage monitoring.

8.3.2 Output Drive, OUT

The gate of an external N-channel MOSFET is connected to this terminal. This output transitions to a high level when an overvoltage condition is detected and after the programmed delay timer. The OUT will reset to a low level if the cell voltage falls below the V_{OV} threshold before the fixed delay timer expires.

8.3.3 Supply Input, VDD

This terminal is the unregulated input power source for the IC. A series resistor is connected to limit the current, and a capacitor is connected to ground for noise filtering.

8.3.4 Thermal Pad, PWRPAD

For correct operation, the power pad (PWRPAD) is connected to the V_{SS} terminal on the PCB.

8.4 Device Functional Modes

8.4.1 NORMAL Mode

When the cell voltage is below the overvoltage threshold, V_{OV} , the device operates in NORMAL mode. The OUT pin is inactive and is low.

8.4.2 OVERVOLTAGE Mode

OVERVOLTAGE mode is detected if the cell voltage exceeds the overvoltage threshold, V_{OV} , for configured OV delay time. The OUT pin is activated, internally pulled high, after a delay time, t_{DELAY} . An external FET then turns on, shorting the fuse to ground, which allows the battery and/or charger power to blow the fuse. When the cell voltages fall below $(V_{OV} - V_{HYS})$, the device returns to NORMAL mode.

8.4.3 Customer Test Mode

Customer Test Mode (CTM) helps reduce test time for checking the overvoltage delay timer parameter once the circuit is implemented in the battery pack. To enter CTM, VDD should be set to at least 10 V higher than V1 (see Figure 8-2). The delay timer is greater than 10 ms, but considerably shorter than the timer delay in normal operation. To exit CTM, remove the VDD to V1 voltage differential of 10 V so that the decrease in this value automatically causes an exit.

CAUTION

Avoid exceeding any Absolute Maximum Voltages on any pins when placing the part into CTM. Also avoid exceeding Absolute Maximum Voltage for the cell voltage ($V1-V_{SS}$). Stressing the pins beyond the rated limits may cause permanent damage to the device.

Figure 8-2 shows the timing for the CTM.

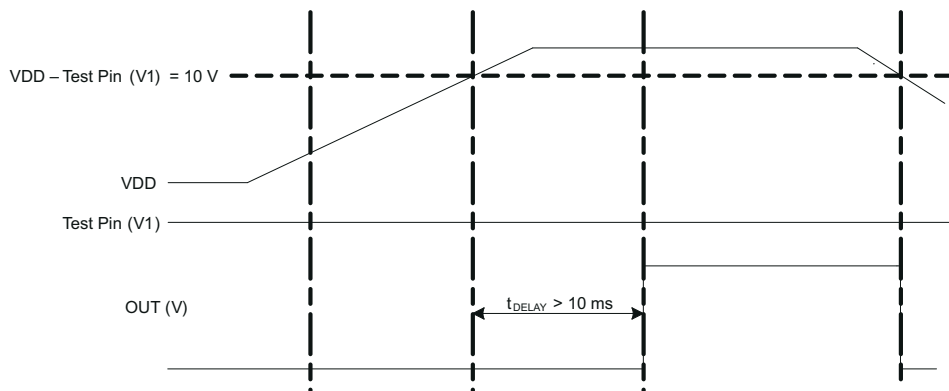

Figure 8-2. Timing for Customer Test Mode

Figure 8-3 shows the measurement for current consumption for the product for both VDD and V_x .

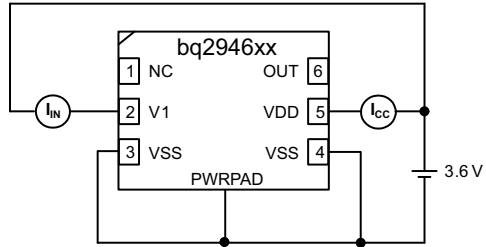

Figure 8-3. Configuration for IC Current Consumption Test

Application and Implementation

Note

Information in the following applications sections is not part of the TI component specification, and TI does not warrant its accuracy or completeness. TI's customers are responsible for determining suitability of components for their purposes. Customers should validate and test their design implementation to confirm system functionality.

9.1 Application Information

The BQ2946xx devices are a family of second-level protectors used for overvoltage protection of the single-cell battery pack in the application. The OUT pin drives a NMOS FET that connects the fuse to ground in the event of a fault condition. This provides a shorted path to use the battery and/or charger power to blow the fuse and cut the power path.

9.1.1 Application Configuration

Changes to the ranges stated in [Table 9-1](#) may impact the accuracy of the cell measurements. [Figure 9-1](#) shows each external component.

9.1.2

Note

Connect VSS (pins 3 and 4) externally to the CELL– terminal.

9.2 Typical Application

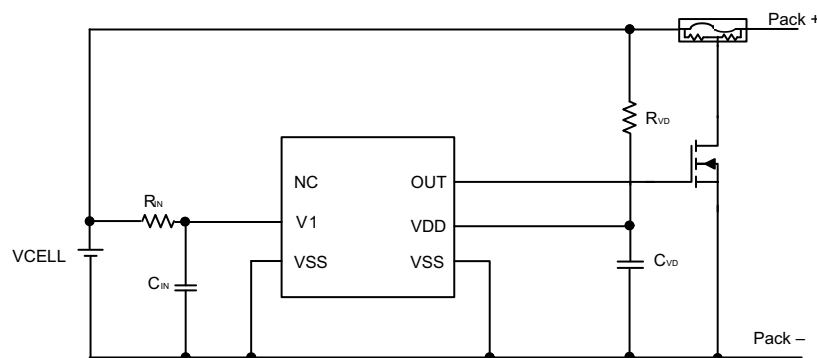

Figure 9-1. Application Configuration Schematic

Note

Connect VSS (pins 3 and 4) externally to the CELL– terminal.

9.2.1 Design Requirements

For this design example, use the parameters listed in [Table 9-1](#) as the input parameters.

Table 9-1. Parameters

PARAMETER	EXTERNAL COMPONENT	MIN	NOM	MAX	UNIT
Voltage monitor filter resistance	RIN	900	1000	1100	Ω
Voltage monitor filter capacitance	CIN	0.01	0.1		μF
Supply voltage filter resistance	RVD	100		1K	Ω
Supply voltage filter capacitance	CVD		0.1		μF

9.2.2 Detailed Design Procedure

1. Determine the overvoltage protection and delay. Select a device with the corresponding thresholds.
2. Follow the application schematic (see [Figure 9-1](#)) to connect the device.
3. Ensure both Vss pins are connected to the CELL– terminal on the PCB layout.

9.2.3 Application Curves

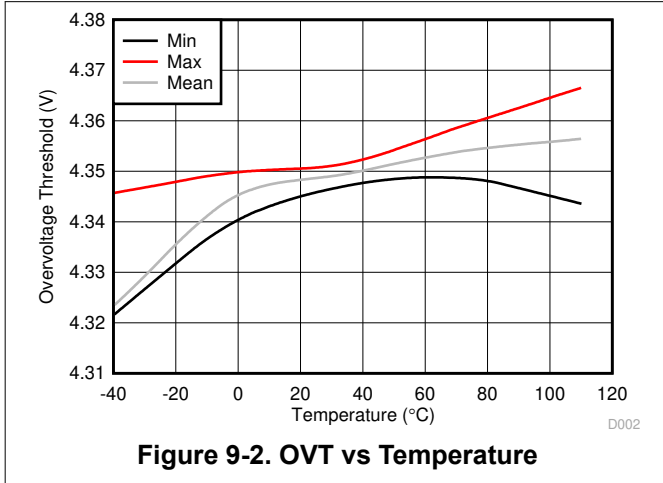

Figure 9-2. OVT vs Temperature

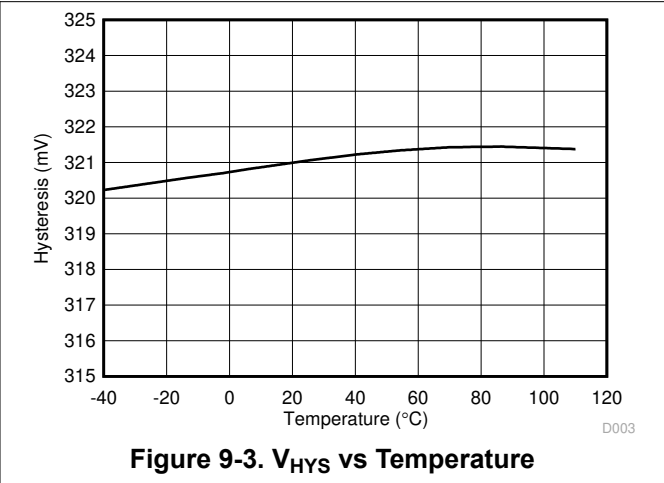

Figure 9-3. V_{HYS} vs Temperature

9.3 System Example

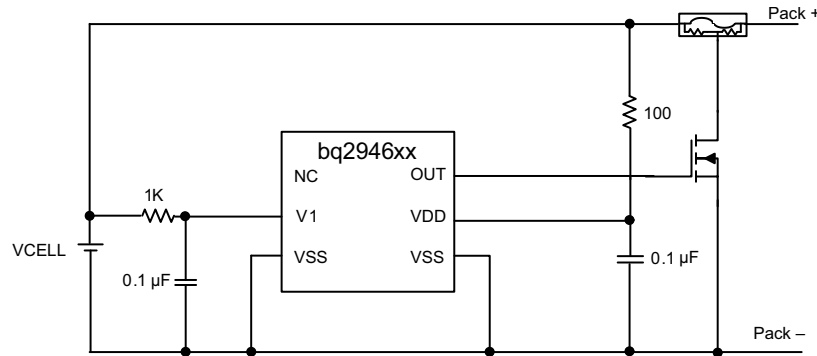

Figure 9-4. 1-Cell Configuration With Fixed Delay

Power Supply Recommendations

The maximum power of this device is 8 V on VDD.

9 Layout

9.1 Layout Guidelines

1. Ensure the RC filters for the V1 and VDD pins are placed as close as possible to the target terminal, reducing the tracing loop area.
2. The VSS pin should be routed to the CELL– terminal.
3. Ensure the trace connecting the fuse to the gate, source of the NFET to the Pack is sufficient to withstand the current during a fuse blown event.

9.2 Layout Example

Place the RC filters close to the device terminals

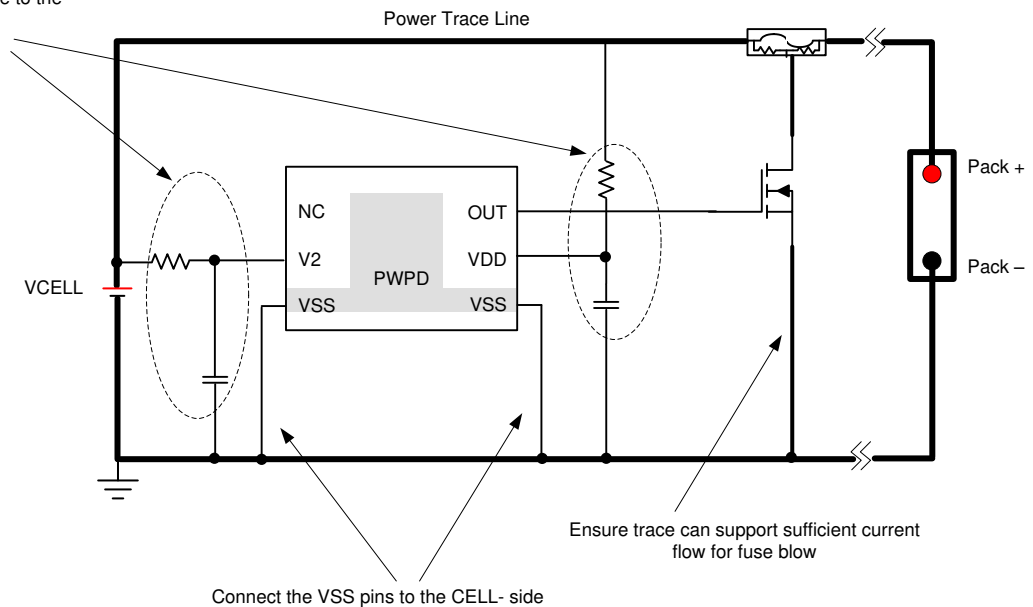

Figure 9-1. Layout Schematic

10 Device and Documentation Support

10.1 Third-Party Products Disclaimer

TI'S PUBLICATION OF INFORMATION REGARDING THIRD-PARTY PRODUCTS OR SERVICES DOES NOT CONSTITUTE AN ENDORSEMENT REGARDING THE SUITABILITY OF SUCH PRODUCTS OR SERVICES OR A WARRANTY, REPRESENTATION OR ENDORSEMENT OF SUCH PRODUCTS OR SERVICES, EITHER ALONE OR IN COMBINATION WITH ANY TI PRODUCT OR SERVICE.

10.2 Receiving Notification of Documentation Updates

To receive notification of documentation updates, navigate to the device product folder on ti.com. In the upper right corner, click on *Alert me* to register and receive a weekly digest of any product information that has changed. For change details, review the revision history included in any revised document.

10.3 Support Resources

[TI E2E™ support forums](#) are an engineer's go-to source for fast, verified answers and design help — straight from the experts. Search existing answers or ask your own question to get the quick design help you need.

Linked content is provided "AS IS" by the respective contributors. They do not constitute TI specifications and do not necessarily reflect TI's views; see TI's [Terms of Use](#).

10.4 Trademarks

TI E2E™ is a trademark of Texas Instruments.
All trademarks are the property of their respective owners.

10.5 Electrostatic Discharge Caution



This integrated circuit can be damaged by ESD. Texas Instruments recommends that all integrated circuits be handled with appropriate precautions. Failure to observe proper handling and installation procedures can cause damage.

ESD damage can range from subtle performance degradation to complete device failure. Precision integrated circuits may be more susceptible to damage because very small parametric changes could cause the device not to meet its published specifications.

10.6 Glossary

[TI Glossary](#) This glossary lists and explains terms, acronyms, and definitions.

Mechanical, Packaging, and Orderable Information

The following pages include mechanical, packaging, and orderable information. This information is the most current data available for the designated devices. This data is subject to change without notice and revision of this document. For browser-based versions of this data sheet, refer to the left-hand navigation.

PACKAGING INFORMATION

Orderable Device	Status (1)	Package Type	Package Drawing	Pins	Package Qty	Eco Plan (2)	Lead finish/ Ball material (6)	MSL Peak Temp (3)	Op Temp (°C)	Device Marking (4/5)	Samples
BQ294602DRVR	ACTIVE	WSON	DRV	6	3000	RoHS & Green	NIPDAU	Level-2-260C-1 YEAR	-40 to 110	4602	Samples
BQ294602DRVT	ACTIVE	WSON	DRV	6	250	RoHS & Green	NIPDAU	Level-2-260C-1 YEAR	-40 to 110	4602	Samples
BQ294604DRVR	ACTIVE	WSON	DRV	6	3000	RoHS & Green	NIPDAU	Level-2-260C-1 YEAR	-40 to 110	4604	Samples
BQ294604DRVT	ACTIVE	WSON	DRV	6	250	RoHS & Green	NIPDAU	Level-2-260C-1 YEAR	-40 to 110	4604	Samples
BQ294624DRVR	ACTIVE	WSON	DRV	6	3000	RoHS & Green	NIPDAU	Level-2-260C-1 YEAR	-40 to 110	4624	Samples
BQ294624DRVT	ACTIVE	WSON	DRV	6	250	RoHS & Green	NIPDAU	Level-2-260C-1 YEAR	-40 to 110	4624	Samples
BQ294682DRVR	ACTIVE	WSON	DRV	6	3000	RoHS & Green	NIPDAU	Level-2-260C-1 YEAR	-40 to 110	4682	Samples
BQ294682DRVT	ACTIVE	WSON	DRV	6	250	RoHS & Green	NIPDAU	Level-2-260C-1 YEAR	-40 to 110	4682	Samples

(1) The marketing status values are defined as follows:

ACTIVE: Product device recommended for new designs.

LIFEBUY: TI has announced that the device will be discontinued, and a lifetime-buy period is in effect.

NRND: Not recommended for new designs. Device is in production to support existing customers, but TI does not recommend using this part in a new design.

PREVIEW: Device has been announced but is not in production. Samples may or may not be available.

OBSELETE: TI has discontinued the production of the device.

(2) **RoHS:** TI defines "RoHS" to mean semiconductor products that are compliant with the current EU RoHS requirements for all 10 RoHS substances, including the requirement that RoHS substance do not exceed 0.1% by weight in homogeneous materials. Where designed to be soldered at high temperatures, "RoHS" products are suitable for use in specified lead-free processes. TI may reference these types of products as "Pb-Free".

RoHS Exempt: TI defines "RoHS Exempt" to mean products that contain lead but are compliant with EU RoHS pursuant to a specific EU RoHS exemption.

Green: TI defines "Green" to mean the content of Chlorine (Cl) and Bromine (Br) based flame retardants meet JS709B low halogen requirements of <=1000ppm threshold. Antimony trioxide based flame retardants must also meet the <=1000ppm threshold requirement.

(3) MSL, Peak Temp. - The Moisture Sensitivity Level rating according to the JEDEC industry standard classifications, and peak solder temperature.

(4) There may be additional marking, which relates to the logo, the lot trace code information, or the environmental category on the device.

(5) Multiple Device Markings will be inside parentheses. Only one Device Marking contained in parentheses and separated by a "~" will appear on a device. If a line is indented then it is a continuation of the previous line and the two combined represent the entire Device Marking for that device.

⁽⁶⁾ Lead finish/Ball material - Orderable Devices may have multiple material finish options. Finish options are separated by a vertical ruled line. Lead finish/Ball material values may wrap to two lines if the finish value exceeds the maximum column width.

Important Information and Disclaimer:The information provided on this page represents TI's knowledge and belief as of the date that it is provided. TI bases its knowledge and belief on information provided by third parties, and makes no representation or warranty as to the accuracy of such information. Efforts are underway to better integrate information from third parties. TI has taken and continues to take reasonable steps to provide representative and accurate information but may not have conducted destructive testing or chemical analysis on incoming materials and chemicals. TI and TI suppliers consider certain information to be proprietary, and thus CAS numbers and other limited information may not be available for release.

In no event shall TI's liability arising out of such information exceed the total purchase price of the TI part(s) at issue in this document sold by TI to Customer on an annual basis.

TAPE AND REEL INFORMATION

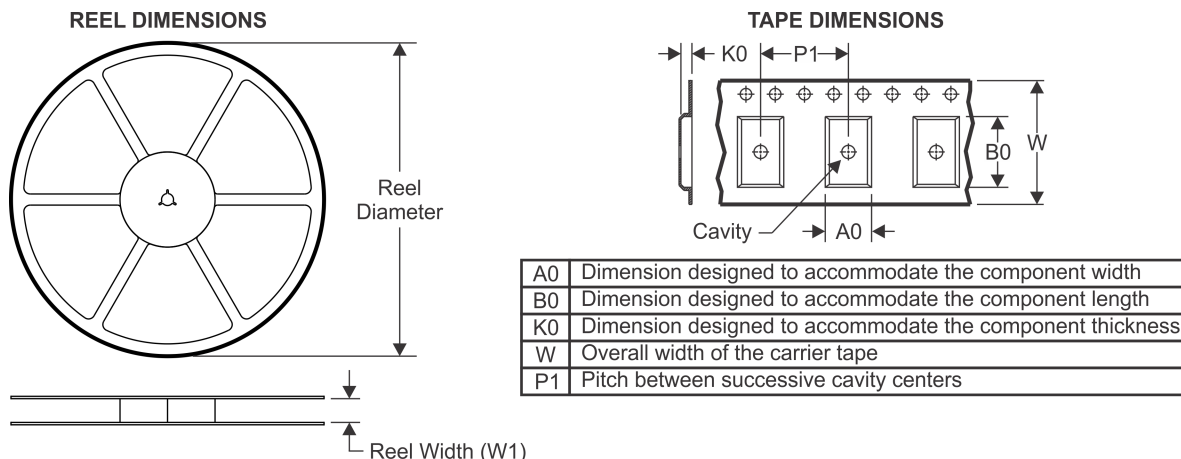

QUADRANT ASSIGNMENTS FOR PIN 1 ORIENTATION IN TAPE



*All dimensions are nominal

Device	Package Type	Package Drawing	Pins	SPQ	Reel Diameter (mm)	Reel Width W1 (mm)	A0 (mm)	B0 (mm)	K0 (mm)	P1 (mm)	W (mm)	Pin1 Quadrant
BQ294602DRVR	WSON	DRV	6	3000	180.0	8.4	2.3	2.3	1.15	4.0	8.0	Q2
BQ294602DRVR	WSON	DRV	6	3000	180.0	8.4	2.3	2.3	1.15	4.0	8.0	Q2
BQ294602DRVT	WSON	DRV	6	250	180.0	8.4	2.3	2.3	1.15	4.0	8.0	Q2
BQ294602DRVT	WSON	DRV	6	250	180.0	8.4	2.3	2.3	1.15	4.0	8.0	Q2
BQ294604DRVR	WSON	DRV	6	3000	180.0	8.4	2.3	2.3	1.15	4.0	8.0	Q2
BQ294604DRVR	WSON	DRV	6	3000	180.0	8.4	2.3	2.3	1.15	4.0	8.0	Q2
BQ294604DRVT	WSON	DRV	6	250	180.0	8.4	2.3	2.3	1.15	4.0	8.0	Q2
BQ294604DRVT	WSON	DRV	6	250	180.0	8.4	2.3	2.3	1.15	4.0	8.0	Q2
BQ294624DRVR	WSON	DRV	6	3000	180.0	8.4	2.3	2.3	1.15	4.0	8.0	Q2
BQ294624DRVT	WSON	DRV	6	250	180.0	8.4	2.3	2.3	1.15	4.0	8.0	Q2
BQ294682DRVR	WSON	DRV	6	3000	180.0	8.4	2.3	2.3	1.15	4.0	8.0	Q2
BQ294682DRVR	WSON	DRV	6	3000	180.0	8.4	2.3	2.3	1.15	4.0	8.0	Q2
BQ294682DRVT	WSON	DRV	6	250	180.0	8.4	2.3	2.3	1.15	4.0	8.0	Q2
BQ294682DRVT	WSON	DRV	6	250	180.0	8.4	2.3	2.3	1.15	4.0	8.0	Q2

TAPE AND REEL BOX DIMENSIONS

*All dimensions are nominal

Device	Package Type	Package Drawing	Pins	SPQ	Length (mm)	Width (mm)	Height (mm)
BQ294602DRVR	WSON	DRV	6	3000	210.0	185.0	35.0
BQ294602DRVR	WSON	DRV	6	3000	210.0	185.0	35.0
BQ294602DRVT	WSON	DRV	6	250	210.0	185.0	35.0
BQ294602DRVT	WSON	DRV	6	250	210.0	185.0	35.0
BQ294604DRVR	WSON	DRV	6	3000	210.0	185.0	35.0
BQ294604DRVR	WSON	DRV	6	3000	210.0	185.0	35.0
BQ294604DRVT	WSON	DRV	6	250	210.0	185.0	35.0
BQ294604DRVT	WSON	DRV	6	250	210.0	185.0	35.0
BQ294624DRVR	WSON	DRV	6	3000	210.0	185.0	35.0
BQ294624DRVT	WSON	DRV	6	250	210.0	185.0	35.0
BQ294682DRVR	WSON	DRV	6	3000	210.0	185.0	35.0
BQ294682DRVR	WSON	DRV	6	3000	210.0	185.0	35.0
BQ294682DRVT	WSON	DRV	6	250	210.0	185.0	35.0
BQ294682DRVT	WSON	DRV	6	250	210.0	185.0	35.0

GENERIC PACKAGE VIEW

DRV 6

WSON - 0.8 mm max height

PLASTIC SMALL OUTLINE - NO LEAD

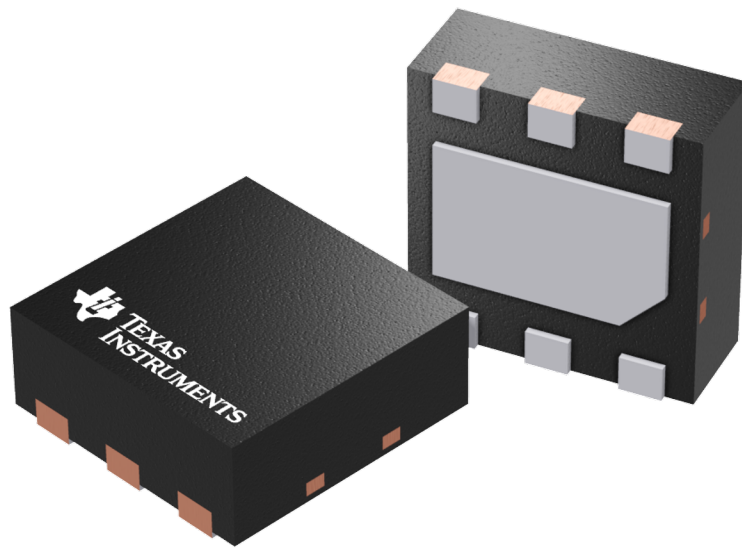

Images above are just a representation of the package family, actual package may vary.
Refer to the product data sheet for package details.

4206925/F

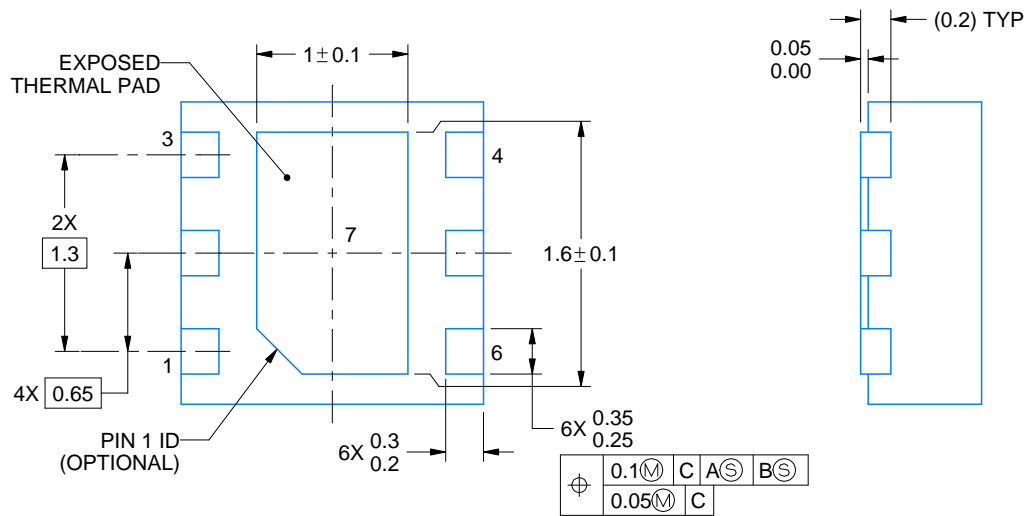
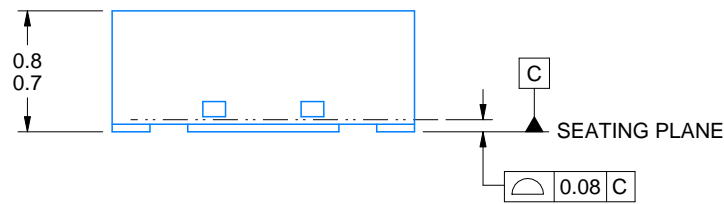
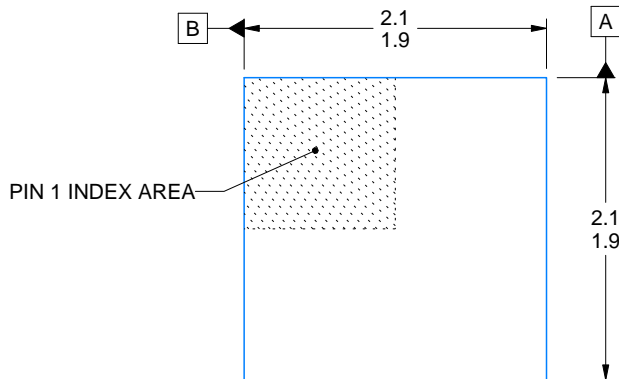
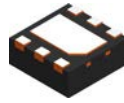

4222173/B 04/2018

NOTES:

1. All linear dimensions are in millimeters. Any dimensions in parenthesis are for reference only. Dimensioning and tolerancing per ASME Y14.5M.
2. This drawing is subject to change without notice.
3. The package thermal pad must be soldered to the printed circuit board for thermal and mechanical performance.

EXAMPLE STENCIL DESIGN

DRV0006A

WSON - 0.8 mm max height

PLASTIC SMALL OUTLINE - NO LEAD

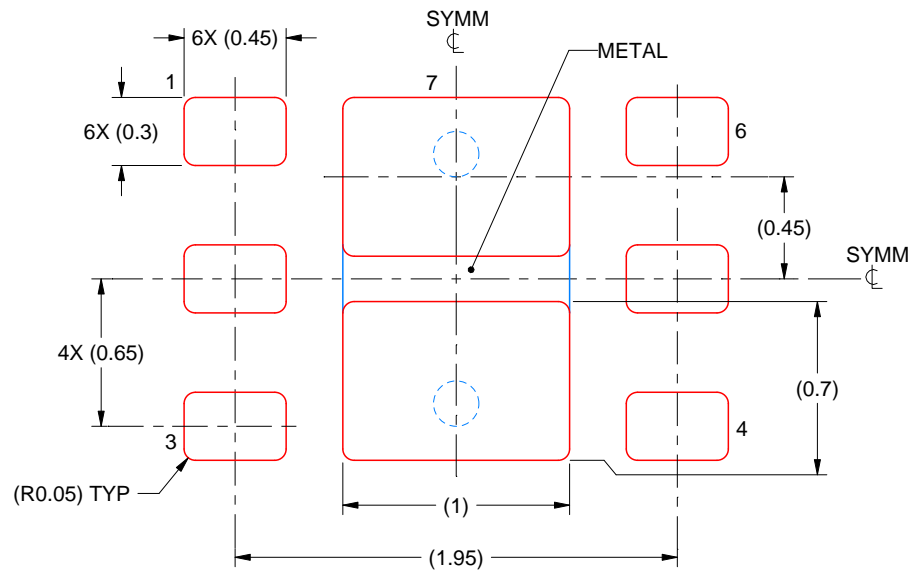

SOLDER PASTE EXAMPLE
BASED ON 0.125 mm THICK STENCIL

EXPOSED PAD #7
88% PRINTED SOLDER COVERAGE BY AREA UNDER PACKAGE
SCALE:30X

4222173/B 04/2018

NOTES: (continued)

6. Laser cutting apertures with trapezoidal walls and rounded corners may offer better paste release. IPC-7525 may have alternate design recommendations.

IMPORTANT NOTICE AND DISCLAIMER

TI PROVIDES TECHNICAL AND RELIABILITY DATA (INCLUDING DATASHEETS), DESIGN RESOURCES (INCLUDING REFERENCE DESIGNS), APPLICATION OR OTHER DESIGN ADVICE, WEB TOOLS, SAFETY INFORMATION, AND OTHER RESOURCES "AS IS" AND WITH ALL FAULTS, AND DISCLAIMS ALL WARRANTIES, EXPRESS AND IMPLIED, INCLUDING WITHOUT LIMITATION ANY IMPLIED WARRANTIES OF MERCHANTABILITY, FITNESS FOR A PARTICULAR PURPOSE OR NON-INFRINGEMENT OF THIRD PARTY INTELLECTUAL PROPERTY RIGHTS.

These resources are intended for skilled developers designing with TI products. You are solely responsible for (1) selecting the appropriate TI products for your application, (2) designing, validating and testing your application, and (3) ensuring your application meets applicable standards, and any other safety, security, or other requirements. These resources are subject to change without notice. TI grants you permission to use these resources only for development of an application that uses the TI products described in the resource. Other reproduction and display of these resources is prohibited. No license is granted to any other TI intellectual property right or to any third party intellectual property right. TI disclaims responsibility for, and you will fully indemnify TI and its representatives against, any claims, damages, costs, losses, and liabilities arising out of your use of these resources.

TI's products are provided subject to TI's Terms of Sale (<https://www.ti.com/legal/termsofsale.html>) or other applicable terms available either on [ti.com](https://www.ti.com) or provided in conjunction with such TI products. TI's provision of these resources does not expand or otherwise alter TI's applicable warranties or warranty disclaimers for TI products.

Mailing Address: Texas Instruments, Post Office Box 655303, Dallas, Texas 75265
Copyright © 2021, Texas Instruments Incorporated