

LM36923 高效三串白色 LED 驱动器

1 特性

- 拉电流匹配度 1%（整个过程、电压、温度范围内）
- 灌电流匹配度 3%（整个过程、电压、温度范围内）
- 11 位调光分辨率
- 解决方案效率高达 91.6%
- 在高达 28V 的电压下可驱动 1 至 3 个并行 LED 串
- 脉宽调制 (PWM) 调光输入
- I²C 可编程
- 可选择 500kHz 和 1MHz 开关频率，可选偏移为 -12%
- 自动切换频率模式（250kHz、500kHz、1MHz）
- 四个可配置过压保护阈值（17V、21V、25V、29V）
- 四个可配置过流保护阈值（750mA、1000mA、1250mA、1500mA）
- 热关断保护

2 应用

针对智能手机和平板电脑背光照明的电源

3 说明

LM36923 是一款针对 LCD 显示器背光照明而设计的超紧凑型、高效三串白色 LED 驱动器。该器件可为多达 8 个串联的 LED 供电，每个灯串的电​​流高达 25mA。该器件采用自适应电流调节方法，可在保持电流稳定的同时为每个灯串提供不同的 LED 电压。

LED 电流通过 I²C 接口或逻辑电平 PWM 输入进行调节。PWM 占空比在内部进行感测并映射到一个 11 位电流，从而提供宽范围的 PWM 频率并实现无噪声运行。

该器件的工作输入电压范围为 2.5V 至 5.5V，工作温度范围为 -40°C 至 85°C。

器件信息(1)

| 器件型号 | 封装 | 封装尺寸（最大值） |
|---------|------------|-------------------|
| LM36923 | DSBGA (12) | 1.755mm x 1.355mm |

(1) 要了解所有可用封装，请见数据表末尾的可订购产品附录。

简化电路原理图

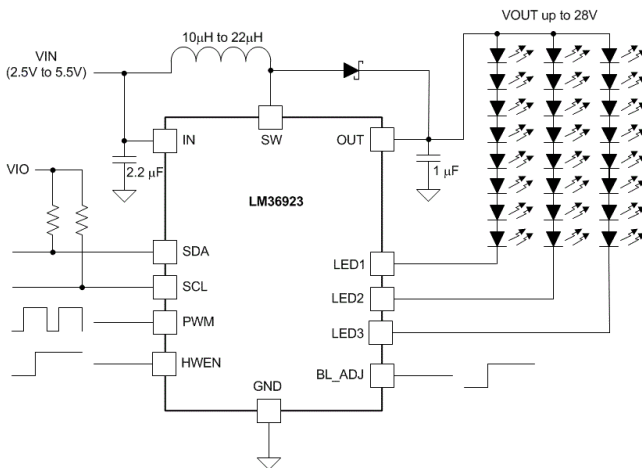

灯串间匹配与 LED 电流间的典型关系

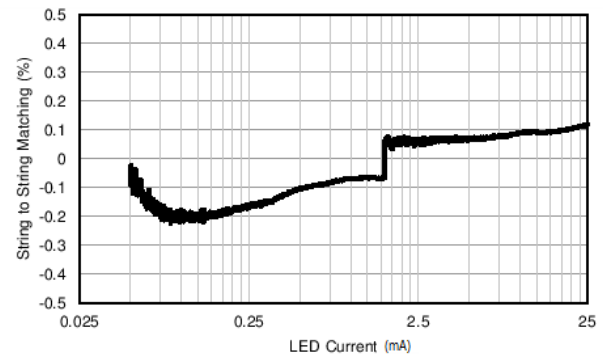

目录

| | | | | | |
|----------|--|-----------|-----------|--|-----------|
| 1 | 特性 | 1 | 7.4 | Device Functional Modes | 16 |
| 2 | 应用 | 1 | 7.5 | Programming | 25 |
| 3 | 说明 | 1 | 7.6 | Register Maps | 26 |
| 4 | 修订历史记录 | 2 | 8 | Applications and Implementation | 29 |
| 5 | Pin Configuration and Functions | 3 | 8.1 | Application Information | 29 |
| 6 | Specifications | 4 | 8.2 | Typical Application | 29 |
| 6.1 | Absolute Maximum Ratings | 4 | 9 | Power Supply Recommendations | 37 |
| 6.2 | ESD Ratings | 4 | 9.1 | Input Supply Bypassing | 37 |
| 6.3 | Recommended Operating Conditions | 4 | 10 | Layout | 37 |
| 6.4 | Thermal Information | 4 | 10.1 | Layout Guidelines | 37 |
| 6.5 | Electrical Characteristics | 5 | 10.2 | Layout Example | 40 |
| 6.6 | I ² C Timing Requirements | 6 | 11 | 器件和文档支持 | 41 |
| 6.7 | Typical Characteristics | 7 | 11.1 | 器件支持 | 41 |
| 7 | Detailed Description | 10 | 11.2 | 商标 | 41 |
| 7.1 | Overview | 10 | 11.3 | 静电放电警告 | 41 |
| 7.2 | Functional Block Diagram | 10 | 11.4 | 术语表 | 41 |
| 7.3 | Feature Description | 11 | 12 | 机械封装和可订购信息 | 41 |

4 修订历史记录

| 日期 | 修订版本 | 注释 |
|------------|------|-------|
| 2015 年 3 月 | * | 最初发布。 |

5 Pin Configuration and Functions

YFF Package
12-Pin DSBGA
Top View

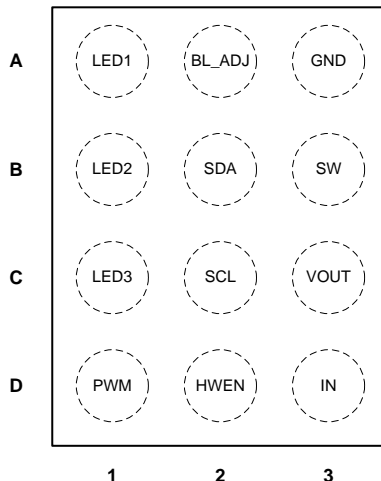

Pin Functions

| PIN | | I/O | DESCRIPTION |
|--------|--------|--------|---|
| NUMBER | NAME | | |
| A1 | LED1 | Input | Input to current sink 1. The boost converter regulates the minimum voltage between LED1, LED2, LED3 to VHR. |
| A2 | BL_ADJ | Input | LED current adjust input. When BL_ADJ is driven to a logic high voltage the LED current steps down to the programmed low current value. |
| A3 | GND | Input | Ground |
| B1 | LED2 | Input | Input pin to current sink 2. The boost converter regulates the minimum voltage between LED1, LED2, LED3 to VHR. |
| B2 | SDA | I/O | Data I/O for I ² C-Compatible Interface. |
| B3 | SW | Output | Drain Connection for internal low side NFET, and anode connection for external Schottky diode. |
| C1 | LED3 | Input | Input pin to current sink 3. The boost converter regulates the minimum voltage between LED1, LED2, LED3 to VHR. |
| C2 | SCL | Input | Clock Input for I ² C-compatible interface. |
| C3 | OUT | Input | OUT serves as the sense point for overvoltage protection. Connect OUT to the positive pin of the output capacitor. |
| D1 | PWM | Input | Logic level input for PWM current control. |
| D2 | HWEN | Input | Hardware enable input. Drive HWEN high to bring the device out of shutdown and allow I ² C writes or PWM control. |
| D3 | IN | Input | Input voltage connection. Bypass IN to GND with a minimum 2.2-μF ceramic capacitor. |

6 Specifications

6.1 Absolute Maximum Ratings

over operating free-air temperature range (unless otherwise noted)⁽¹⁾

| | | MIN | MAX | UNIT |
|-----------------------------|--------------------------------|------|-----|------|
| IN | Input voltage | -0.3 | 6 | V |
| OUT | Output overvoltage sense input | -0.3 | 30 | V |
| SW | Inductor connection | -0.3 | 30 | V |
| LED1, LED2, LED3 | LED string cathode connection | -0.3 | 30 | V |
| HWEN, PWM, SDA, SCL, BL_ADJ | Logic I/Os | -0.3 | 6 | V |
| TJ_MAX | Maximum junction temperature | | 150 | °C |
| T _{stg} | Storage temperature | -65 | 150 | °C |

- (1) Stresses beyond those listed under absolute maximum ratings may cause permanent damage to the device. These are stress ratings only, and functional operation of the device at these or any other conditions beyond those indicated under recommended operating conditions is not implied. Exposure to absolute-maximum-rated conditions for extended periods may affect device reliability.

6.2 ESD Ratings

| | | VALUE | UNIT |
|--------------------|-------------------------|--|-------|
| V _(ESD) | Electrostatic discharge | Human-body model (HBM), per ANSI/ESDA/JEDEC JS-001 ⁽¹⁾ | ±2000 |
| | | Charged-device model (CDM), per JEDEC specification JESD22-C101 ⁽²⁾ | ±500 |

- (1) JEDEC document JEP155 states that 500-V HBM allows safe manufacturing with a standard ESD control process. Pins listed as ±2000 V may actually have higher performance.
- (2) JEDEC document JEP157 states that 250-V CDM allows safe manufacturing with a standard ESD control process. Pins listed as ±500 V may actually have higher performance.

6.3 Recommended Operating Conditions

over operating free-air temperature range (unless otherwise noted)

| | | MIN | MAX | UNIT |
|-----------------------------|-------------------------------|-----|------|------|
| IN | Input voltage | 2.5 | 5.5 | V |
| OUT | Overvoltage sense input | 0 | 29.5 | V |
| SW | Inductor connection | 0 | 29.5 | V |
| LED1, LED2, LED3 | LED string cathode connection | 0 | 29.5 | V |
| HWEN, PWM, SDA, SCL, BL_ADJ | Logic I/Os | 0 | 5.5 | V |

6.4 Thermal Information

| THERMAL METRIC ⁽¹⁾ | | YFQ (DSBGA) 12 PINS | UNIT |
|-------------------------------|--|------------------------|------|
| R _{θJA} | Junction-to-ambient thermal resistance | 88.9 | °C/W |
| R _{θJC(top)} | Junction-to-case (top) thermal resistance | 0.7 | |
| R _{θJB} | Junction-to-board thermal resistance | 43.9 | |
| Ψ _{θJT} | Junction-to-top characterization parameter | 2.9 | |
| Ψ _{θJB} | Junction-to-board characterization parameter | 43.7 | |

- (1) For more information about traditional and new thermal metrics, see the *IC Package Thermal Metrics* application report, [SPRA953](#).

6.5 Electrical Characteristics

over operating free-air temperature range (unless otherwise noted)

| PARAMETER | | TEST CONDITIONS | | MIN | TYP | MAX | UNIT |
|-------------------|---|---|----------------------------|---------------|------|-------------|---------|
| BOOST | | | | | | | |
| $I_{MATCH}^{(1)}$ | LED current matching I_{LED1} to I_{LED2} to I_{LED3} | $50 \mu A \leq I_{LED} \leq 25 \text{ mA}$, $2.7 \text{ V} \leq V_{IN} \leq 5 \text{ V}$ (linear or exponential mode) | | -1% | 0.1% | 1% | |
| Accuracy | Absolute Accuracy (I_{LED1} , I_{LED2} , I_{LED3}) | $50 \mu A \leq I_{LED} \leq 25 \text{ mA}$, $2.7 \text{ V} \leq V_{IN} \leq 5 \text{ V}$ (linear or exponential mode) | | -3% | 0.1% | 3% | |
| I_{LED_MIN} | Minimum LED current (per string) | PWM or I^2C current control (linear or exponential mode) | | 50 | | μA | |
| I_{LED_MAX} | Maximum LED current (per string) | | | 25 | | mA | |
| R_{DNL} | IDAC ratio-metric DNL | exponential mode only | | 1/3 (0.3%) | | LSB | |
| V_{HR} | Regulated current sink headroom voltage | $I_{LED} = 25 \text{ mA}$ | | 210 | | mV | |
| | | $I_{LED} = 5 \text{ mA}$ | | 100 | | | |
| V_{HR_MIN} | Current sink minimum headroom voltage | $I_{LED} = 95\%$ of nominal, $I_{LED} = 5 \text{ mA}$ | | 35 | 50 | mV | |
| Efficiency | Typical efficiency | $V_{IN} = 3.7 \text{ V}$, $I_{LED} = 5 \text{ mA/string}$, Typical Application circuit (3x7 LEDs), (P_{OUT}/P_{IN}) | | 87% | | | |
| R_{NMOS} | NMOS switch on resistance | $I_{SW} = 250 \text{ mA}$ | | 0.25 | | Ω | |
| I_{CL} | NMOS switch current limit | $2.7 \text{ V} \leq V_{IN} \leq 5 \text{ V}$ | OCP = 00 | 575 | 750 | 875 | mA |
| | | | OCP = 01 | 860 | 1000 | 1110 | |
| | | | OCP = 10 | 1100 | 1250 | 1400 | |
| | | | OCP = 11 | 1350 | 1500 | 1650 | |
| V_{OVP} | Output overvoltage protection | ON threshold, $2.7 \text{ V} \leq V_{IN} \leq 5 \text{ V}$ | OVP = 00 | 16 | 17 | 17.5 | V |
| | | | OVP = 01 | 20 | 21 | 21.5 | |
| | | | OVP = 10 | 24 | 25 | 25.5 | |
| | | | OVP = 11 | 28 | 29 | 29.5 | |
| OVP Hysteresis | | | | 0.5 | | V | |
| f_{SW} | Switching frequency | $2.7 \text{ V} \leq V_{IN} \leq 5 \text{ V}$, boost frequency shift = 0 | Boost frequency select = 0 | 475 | 500 | 525 | kHz |
| | | | Boost frequency select = 1 | 950 | 1000 | 1050 | |
| D_{MAX} | Maximum boost duty cycle | | | 92% | 94% | | |
| I_{SHDN} | Shutdown current | Chip enable bit = 0, SDA = SCL = IN or GND, $2.7 \text{ V} \leq V_{IN} \leq 5 \text{ V}$ | | 1.2 | | 5 | μA |
| T_{SD} | Thermal shutdown | | | 135 | | $^{\circ}C$ | |
| | Hysteresis | | | 15 | | | |
| PWM INPUT | | | | | | | |
| Min f_{PWM} | | | | 50 | | Hz | |
| Max f_{PWM} | | Sample rate = 24 MHz | | 50 | | kHz | |
| t_{MIN_ON} | Minimum pulse ON time | Sample rate = 24 MHz | | 183.3 | | ns | |
| | | Sample rate = 4 MHz | | 1100 | | | |
| | | Sample rate = 800 kHz | | 5500 | | | |
| t_{MIN_OFF} | Minimum pulse OFF time | Sample rate = 24 MHz | | 183.3 | | ns | |
| | | Sample rate = 4 MHz | | 1100 | | | |
| | | Sample rate = 800 kHz | | 5500 | | | |

(1) LED Current Matching between strings is given as the worst case matching between any two strings. Matching is calculated as $((I_{LEDX} - I_{LEDY}) / I_{LED_AVEXY}) \times 100$

Electrical Characteristics (continued)

over operating free-air temperature range (unless otherwise noted)

| PARAMETER | | TEST CONDITIONS | MIN | TYP | MAX | UNIT |
|---------------------------|---|---|------|-----|-----------------|------|
| $t_{\text{START-UP}}$ | Turn-on delay from shutdown to backlight on | PWM input active, PWM = logic high, HWEN input from low to high, $f_{\text{PWM}} = 10 \text{ kHz}$ (50% duty cycle) | | 3.5 | 5 | ms |
| PWM_{RES} | PWM input resolution | $1.6 \text{ kHz} \leq f_{\text{PWM}} \leq 12 \text{ kHz}$, PWM hysteresis = 00, PWM sample rate = 11 | | | 11 | bits |
| V_{IH} | Input logic high | HWEN, BL_ADJ, SCL, SDA, PWM inputs | 1.25 | | V_{IN} | V |
| V_{IL} | Input logic low | HWEN, BL_ADJ, SCL, SDA, PWM inputs | 0 | | 0.4 | |
| t_{GLITCH} | PWM input glitch rejection | PWM pulse filter = 00 | | 0 | 15 | ns |
| | | PWM pulse filter = 01 | 60 | 100 | 140 | |
| | | PWM pulse filter = 10 | 90 | 150 | 210 | |
| | | PWM pulse filter = 11 | 120 | 200 | 280 | |
| $t_{\text{PWM_STBY}}$ | PWM shutdown period | Sample rate = 24 MHz | 0.54 | 0.6 | 0.66 | ms |
| | | Sample rate = 4 MHz | 2.7 | 3 | 3.3 | |
| | | Sample rate = 800 kHz | 22.5 | 25 | 27.5 | |

6.6 I²C Timing Requirements

| | | MIN | TYP | MAX | UNIT |
|-------|--|-----|-----|-----|---------------|
| t_1 | SCL clock period | 2.5 | | | μs |
| t_2 | Data in setup time to SCL high | 100 | | | ns |
| t_3 | Data out stable after SCL low | 0 | | | ns |
| t_4 | SDA low Setup Time to SCL low (start) | 100 | | | ns |
| t_5 | SDA high hold time after SCL high (stop) | 100 | | | ns |

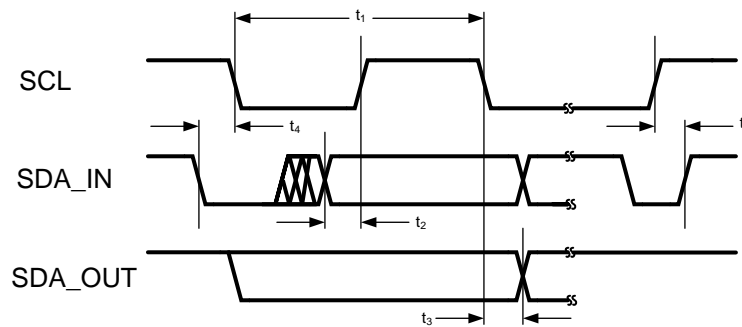
 图 1. I²C Timing

6.7 Typical Characteristics



图 2. OVP Hysteresis



图 3. 17-V OVP Threshold

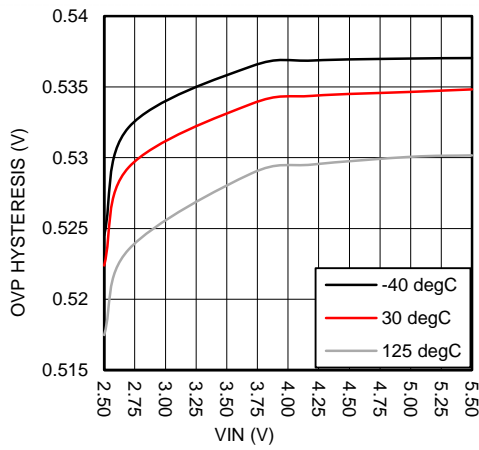

图 4. 21-V OVP Threshold

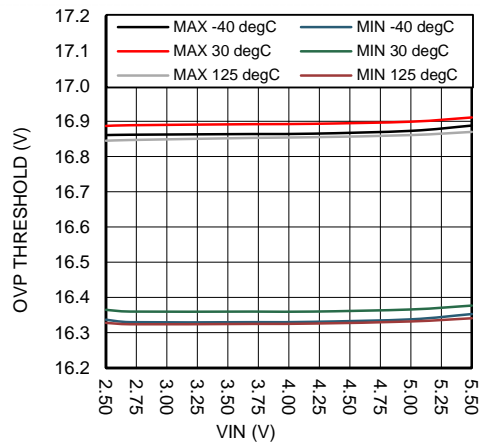

图 5. 25-V OVP Threshold

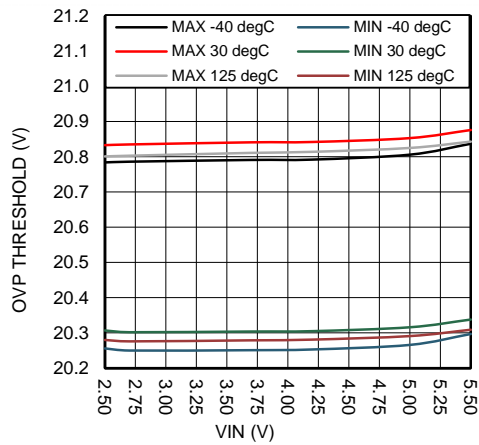

图 6. 29-V OVP Threshold

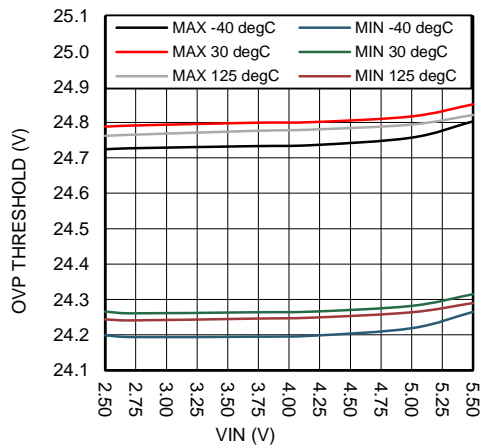

图 7. RDSON

Typical Characteristics (接下页)

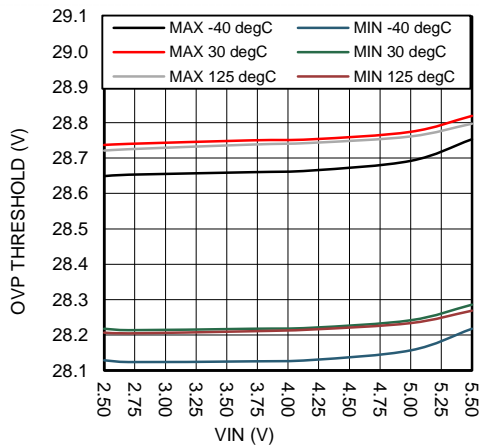

HWEN = GND

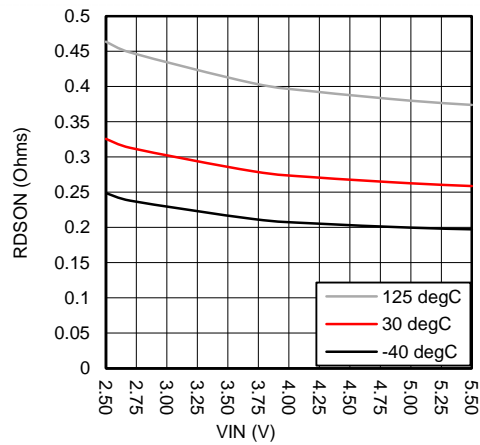
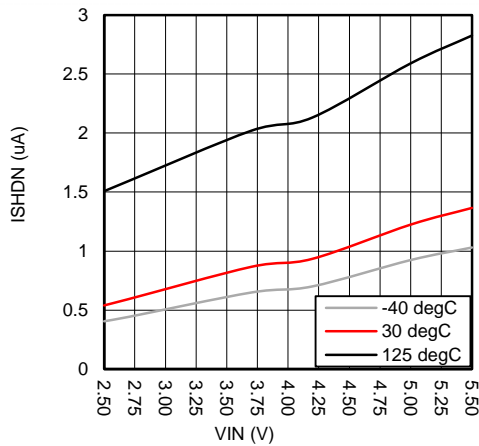
图 8. Shutdown Current

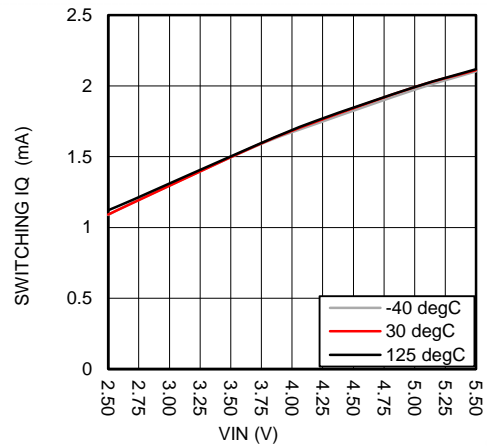

$f_{SW} = 1 \text{ Mhz}$

No Load

图 9. I_Q Current (Switching)

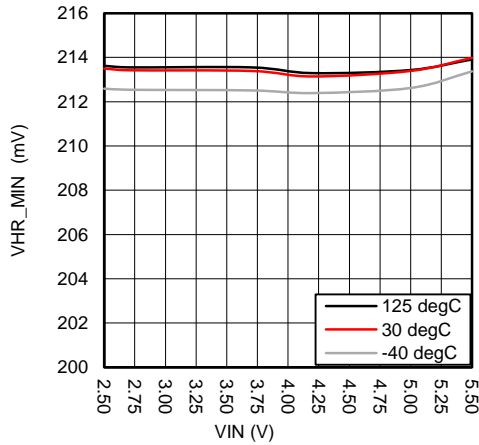

$I_{LED} = 25 \text{ mA}$

图 10. VHR MIN

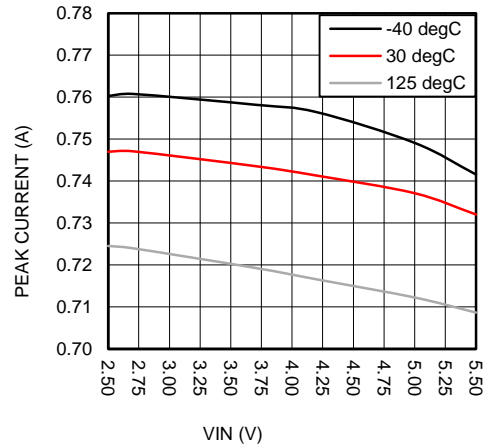

Open Loop

图 11. 750-mA OCP Current

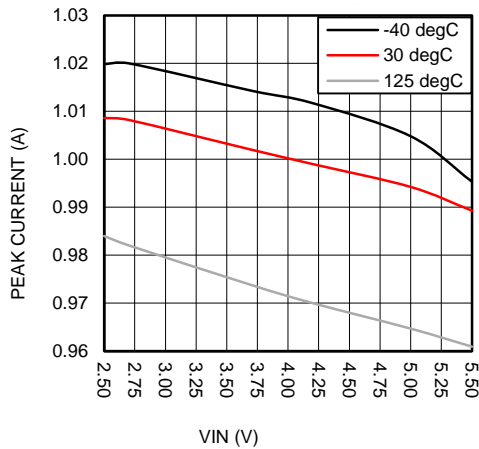

Open Loop

图 12. 1000-mA OCP Current

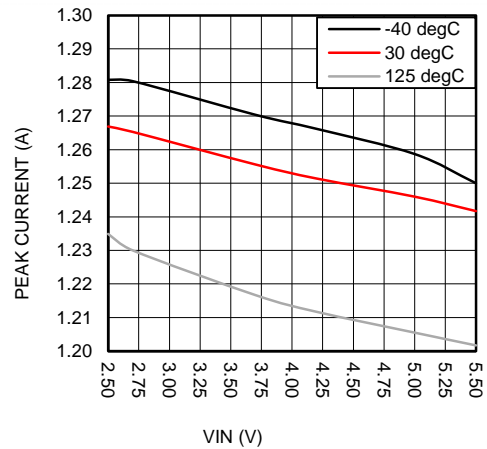

Open Loop

图 13. 1250-mA OCP Current

Typical Characteristics (接下页)

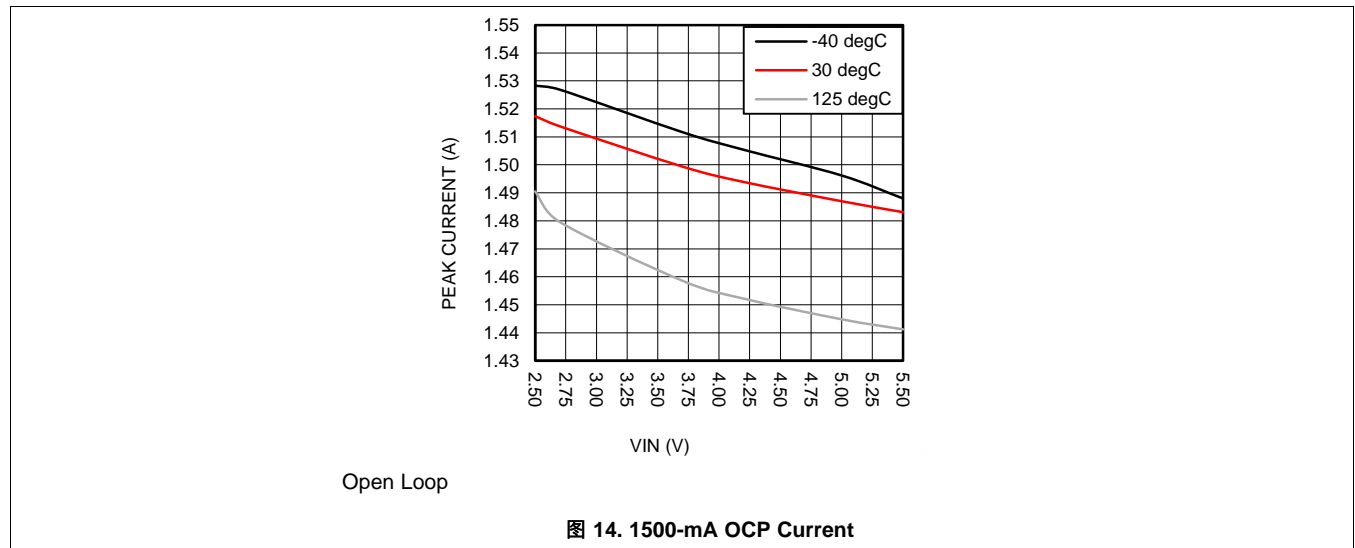

7 Detailed Description

7.1 Overview

The LM36923 is an inductive boost plus 3 current sink white-LED driver designed for powering from one to three strings of white LEDs used in display backlighting. The device operates over the 2.5-V to 5.5-V input voltage range. The 11-bit LED current is set via an I²C interface, via a logic level PWM input, or a combination of both.

7.2 Functional Block Diagram

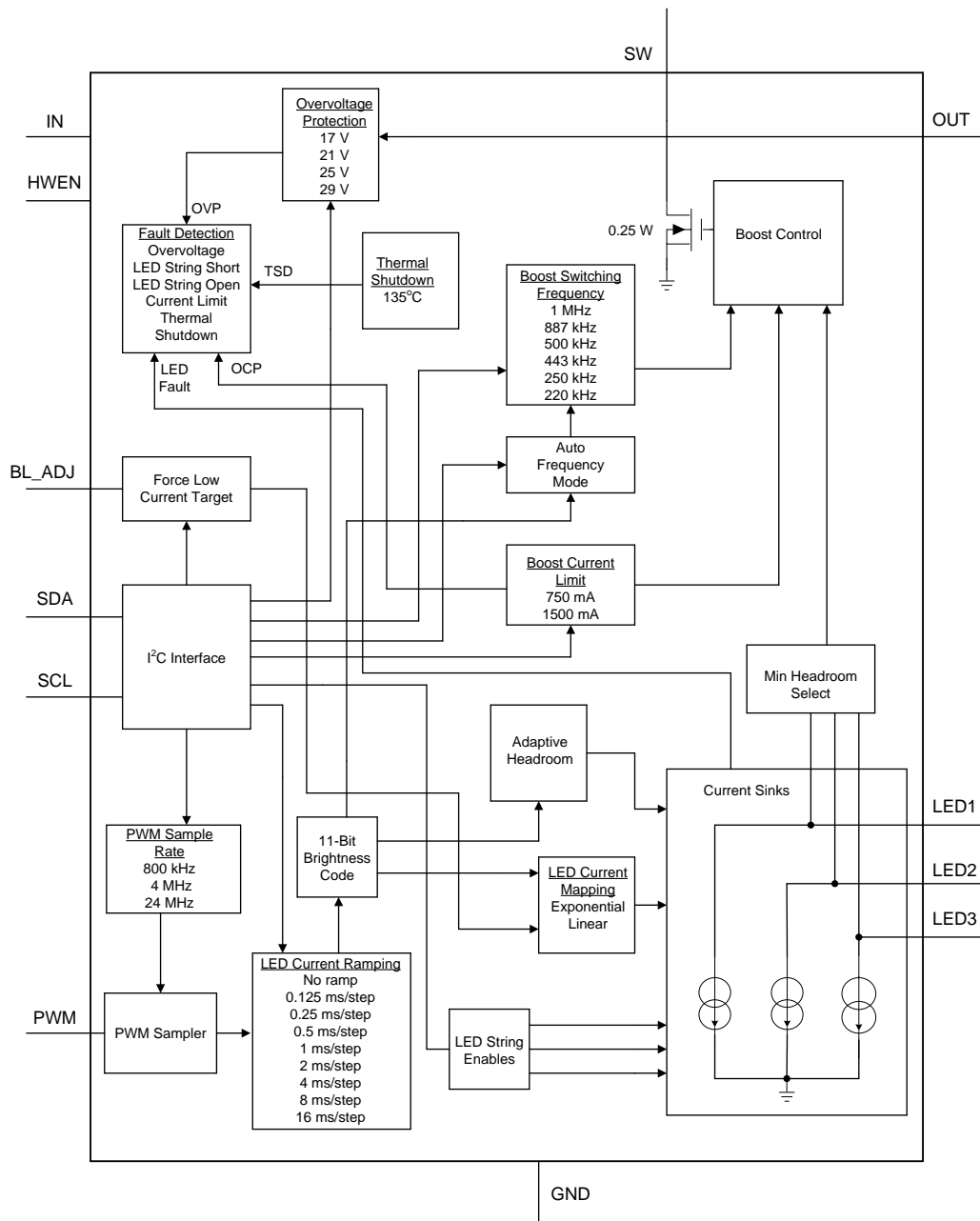

7.3 Feature Description

7.3.1 Enabling the LM36923

The LM36923 has a logic level input HWEN which serves as the master enable/disable for the device. When HWEN is low the device is disabled, the registers are reset to their default state, the I²C bus is inactive, and the device is placed in a low-power shutdown mode. When HWEN is forced high the device is enabled, and I²C writes are allowed to the device.

7.3.1.1 Current Sink Enable

Each current sink in the device has a separate enable input. This allows for a 1-string, 2-string, or 3-string application. The default is with three strings enabled. Once the correct LED string configuration is programmed, the device can be enabled by writing the chip enable bit high (register 0x10 bit[0]), and then either enabling PWM and driving PWM high, or writing a non-zero code to the brightness registers.

The default setting for the device is with the chip enable bit set to 1, PWM input enabled, and the device in linear mapped mode. Therefore, on power up once HWEN is driven high, the device enters the standby state and actively monitors the PWM input. After a non-zero PWM duty cycle is detected the LM36923 converts the duty cycle information to the linearly weighted 11-bit brightness code. This allows for operation of the device in a stand-alone configuration without the need for any I²C writes. 图 15 and 图 16 describe the start-up timing for operation with both PWM controlled current and with I²C controlled current.



图 15. Enabling the LM36923 via PWM



图 16. Enabling the LM36923 via I²C

Feature Description (接下页)

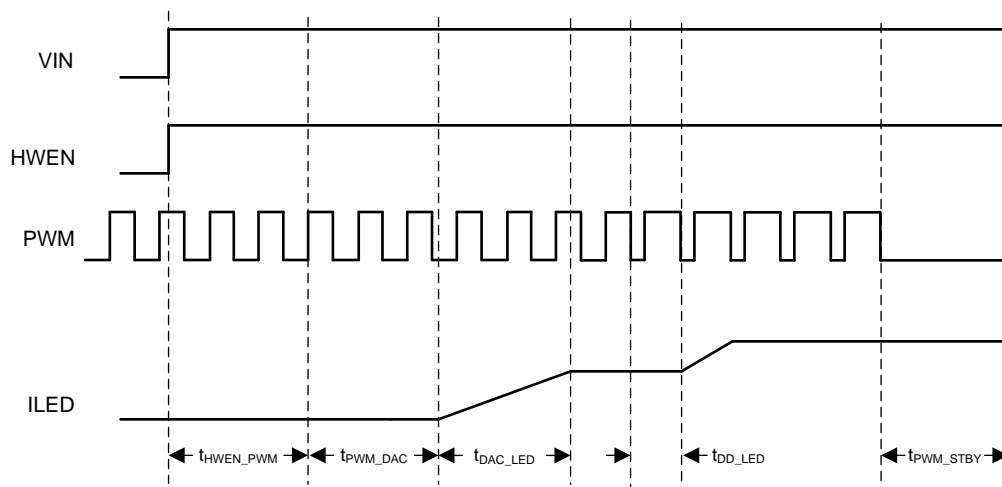
7.3.2 LM36923 Start-Up

The LM36923 can be enabled or disabled in various ways. When disabled, the device is considered shutdown, and the quiescent current drops to I_{SHDN} . When the device is in standby, it returns to the I_{SHDN} current level retaining all programmed register values. 表 1 describes the different operating states for the LM36923.

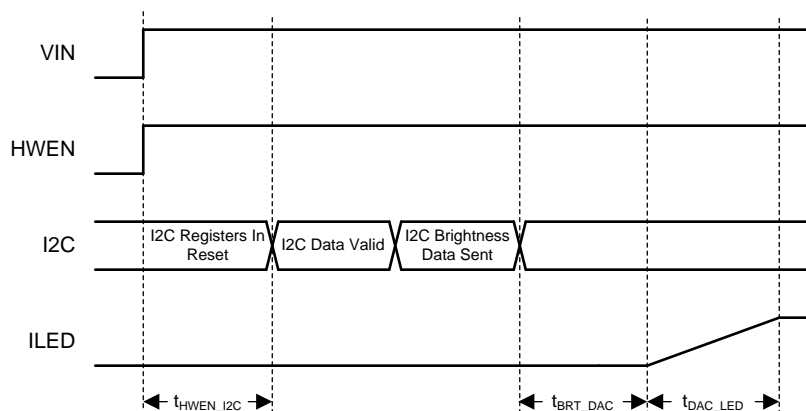
表 1. LM36923 Operating Modes

| LED STRING ENABLES 0x10 bits[3:1] | PWM INPUT | I ² C BRIGHTNESS REGISTERS 0x18 bits[2:0] 0x19 bits[7:0] | BRIGHTNESS MODE 0x11 bits[6:5] | DEVICE ENABLE 0x10 bit[0] | LED CURRENT | |
|--------------------------------------|------------|---|-----------------------------------|------------------------------|---|---|
| | | | | | (EXP MAPPING) 0x11 bit[7] = 1 | (LIN MAPPING) 0x11 bit[7] = 0 |
| XXX | X | XXX | XX | 0 | Off, device disabled | |
| 0 | X | XXX | XX | 1 | Off, device standby | |
| At least one enabled | X | 0 | 00 | 1 | Off, device in standby | |
| At least one enabled | X | Code > 000 | 00 | 1 | $I_{LED} = 50\mu A \times 1.003040572^{Code}$ See ⁽¹⁾ | $I_{LED} = 37.806\mu A + 12.195\mu A \times Code$ See ⁽¹⁾ |
| At least one enabled | 0 | XXX | 01 | 1 | Off, device in standby | |
| At least one enabled | PWM Signal | XXX | 01 | 1 | $I_{LED} = 50\mu A \times 1.003040572^{Code}$ See ⁽¹⁾ | $I_{LED} = 37.806\mu A + 12.195\mu A \times Code$ See ⁽¹⁾ |
| At least one enabled | 0 | XXX | 10 or 11 | 1 | Off, device in standby | |
| At least one enabled | X | 0 | 10 or 11 | 1 | Off, device in standby | |
| At least one enabled | PWM Signal | Code > 000 | 10 or 11 | 1 | $I_{LED} = 50\mu A \times 1.003040572^{Code}$ See ⁽¹⁾ | $I_{LED} = 37.806\mu A + 12.195\mu A \times Code$ See ⁽¹⁾ |

(1) Code is the 11-bit code output from the ramper (see 图 21, 图 23, 图 25, 图 27). This can be the I²C brightness code, the converted PWM duty cycle or the 11-bit product of both.

7.3.3 Brightness Mapping

There are two different ways to map the brightness code (or PWM duty cycle) to the LED current: linear and exponential mapping.

7.3.3.1 Linear Mapping

For linear mapped mode the LED current increases proportionally to the 11-bit brightness code and follows the relationship:

$$I_{LED} = 37.806\mu A + 12.195\mu A \times Code \tag{1}$$

This is valid from codes 1 to 2047. Code 0 programs 0 current. Code is an 11-bit code that can be the I²C brightness code, the digitized PWM duty cycle, or the product of the two.

7.3.3.2 Exponential Mapping

In exponential mapped mode the LED current follows the relationship:

$$I_{LED} = 50\mu A \times 1.003040572^{Code} \tag{2}$$

This results in an LED current step size of approximately 0.304% per code. This is valid for codes from 1 to 2047. Code 0 programs 0 current. Code is an 11-bit code that can be the I²C brightness code, the digitized PWM duty cycle, or the product of the two. 图 17 details the LED current exponential response.

The 11-bit (0.304%) per code step is small enough such that the transition from one code to the next in terms of LED brightness is not distinguishable to the eye. This therefore gives a perfectly smooth brightness increase between adjacent codes.



图 17. LED Current vs Brightness Code (Exponential Mapping)

7.3.4 PWM Input

The PWM input is a sampled input which converts the input duty cycle information into an 11-bit brightness code. The use of a sampled input eliminates any noise and current ripple that traditional PWM controlled LED drivers are susceptible to.

The PWM input uses logic level thresholds with $V_{IH_MIN} = 1.25\text{ V}$ and $V_{IL_MAX} = 0.4\text{ V}$. Since this is a sampled input, there are limits on the max PWM input frequency as well as the resolution that can be achieved.

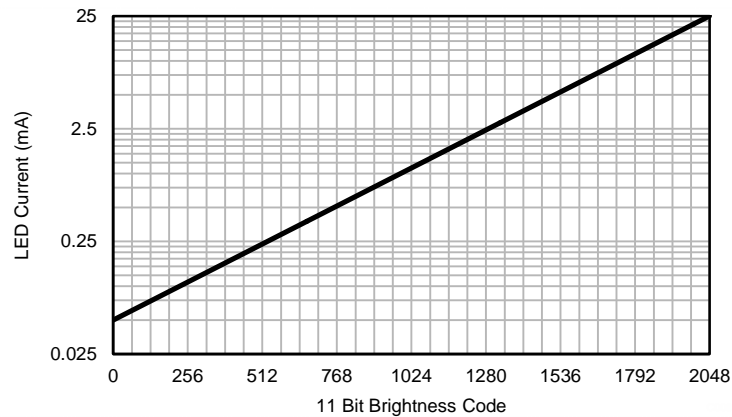
7.3.4.1 PWM Sample Frequency

There are four selectable sample rates for the PWM input. The choice of sample rate depends on three factors:

1. Required PWM Resolution (input duty cycle to brightness code, with 11 bits max)
2. PWM Input Frequency
3. Efficiency

7.3.4.1.1 PWM Resolution and Input Frequency Range

The PWM input frequency range is 50 Hz to 50 kHz. To achieve the full 11-bit maximum resolution of PWM duty cycle to the LED brightness code (BRT), the input PWM duty cycle must be ≥ 11 bits, and the PWM sample period ($1/f_{SAMPLE}$) must be smaller than the minimum PWM input pulse width. 图 18 shows the possible brightness code resolutions based on the input PWM frequency. The minimum PWM frequency for each PWM sample rate is described in [PWM Timeout](#).



图 18. PWM Sample Rate, Resolution, and PWM Input Frequency

7.3.4.1.2 PWM Sample Rate and Efficiency

Efficiency is maximized when the lowest f_{SAMPLE} is chosen since this lowers the quiescent operating current of the device. 表 2 describes the typical efficiency tradeoffs for the different sample clock settings.

表 2. PWM Sample Rate Trade-Offs

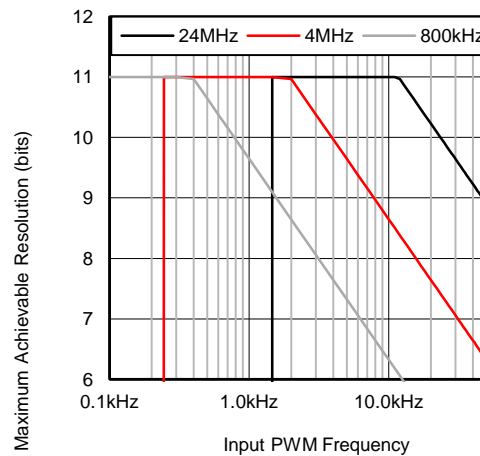
| PWM SAMPLE RATE (f_{SAMPLE}) | TYPICAL INPUT CURRENT, DEVICE ENABLED, $I_{LED} = 10 \text{ mA/string, } 3 \times 5 \text{ LEDs}$ | TYPICAL EFFICIENCY |
|-------------------------------------|--|--------------------------|
| (0x12 Bits[7:6]) | $f_{SW} = 1 \text{ MHz}$ | $V_{IN} = 3.7 \text{ V}$ |
| 0 | 1.03 mA | 90.7% |
| 1 | 1.05 mA | 90.6% |
| 1X | 1.35 mA | 90.4% |

7.3.4.1.2.1 PWM Sample Rate Example

The number of bits of resolution on the PWM input varies according to the PWM Sample rate and PWM input frequency.

表 3. PWM Resolution vs PWM Sample Rate

| PWM FREQUENCY (kHz) | RESOLUTION (PWM SAMPLE RATE = 800 kHz) | RESOLUTION (PWM SAMPLE RATE = 4 MHz) | RESOLUTION (PWM SAMPLE RATE = 24 MHz) |
|------------------------|---|---|--|
| 0.4 | 11 | 11 | 11 |
| 2 | 8.6 | 11 | 11 |
| 12 | 6.1 | 8.4 | 11 |

7.3.4.2 PWM Hysteresis

To prevent jitter at the input PWM signal from feeding through the PWM path and causing oscillations in the LED current, the LM36923 offers 7 selectable hysteresis settings. The hysteresis works by forcing a specific number of 11-bit LSB code transitions to occur in the input duty cycle before the LED current changes. 表 4 describes the hysteresis. The hysteresis only applies during the change in direction of brightness currents. Once the change in direction has taken place, the PWM input must overcome the required LSB(s) of the hysteresis setting before the brightness change takes effect. Once the initial hysteresis has been overcome and the direction in brightness change remains the same, the PWM to current response changes with no hysteresis.

表 4. PWM Input Hysteresis

| HYSTERESIS SETTING (0x12 Bits[4:2]) | MIN CHANGE IN PWM PULSE WIDTH (Δt) REQUIRED TO CHANGE LED CURRENT, AFTER DIRECTION CHANGE (for $f_{PWM} < 11.7 \text{ kHz}$) | MIN CHANGE IN PWM DUTY CYCLE (ΔD) REQUIRED TO CHANGE LED CURRENT AFTER DIRECTION CHANGE | MIN (ΔI_{LED}), INCREASE FOR INITIAL CODE CHANGE | |
|--|---|--|--|-------------|
| | | | EXPONENTIAL MODE | LINEAR MODE |
| 000 (0 LSB) | $1/(f_{PWM} \times 2047)$ | 0.05% | 0.30% | 0.05% |
| 001 (1 LSB) | $1/(f_{PWM} \times 1023)$ | 0.10% | 0.61% | 0.10% |
| 010 (2 LSBs) | $1/(f_{PWM} \times 511)$ | 0.20% | 1.21% | 0.20% |
| 011 (3 LSBs) | $1/(f_{PWM} \times 255)$ | 0.39% | 2.40% | 0.39% |
| 100 (4 LSBs) | $1/(f_{PWM} \times 127)$ | 0.78% | 4.74% | 0.78% |
| 101 (5 LSBs) | $1/(f_{PWM} \times 63)$ | 1.56% | 9.26% | 1.56% |
| 110 (6 LSBs) | $1/(f_{PWM} \times 31)$ | 3.12% | 17.66% | 3.12% |

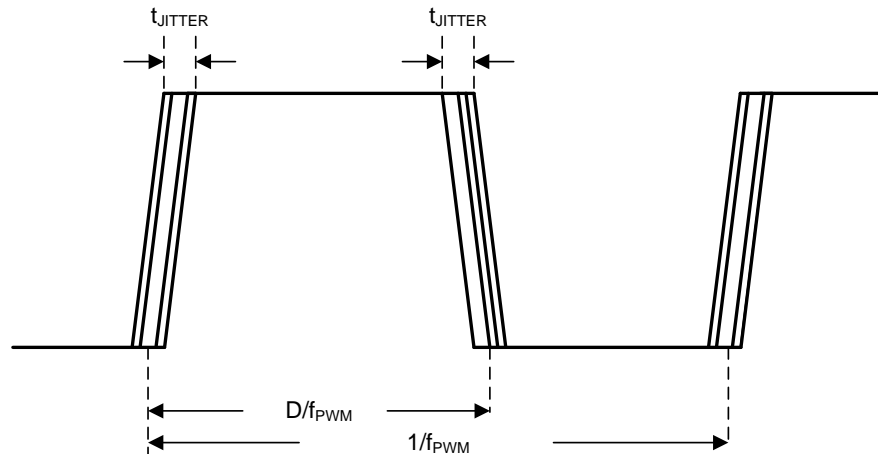

- D is $t_{\text{JITTER}} \times f_{\text{PWM}}$ or equal to #LSB's = $\Delta D \times 2048$ codes.
- For 11-bit resolution, #LSBs is equal to a hysteresis setting of $\text{LN}(\# \text{LSB's})/\text{LN}(2)$.
- For example, with a t_{JITTER} of 1 μs and a f_{PWM} of 5 kHz, the hysteresis setting should be:
 $\text{LN}(1 \mu\text{s} \times 5 \text{ kHz} \times 2048)/\text{LN}(2) = 3.35$ (4 LSBs).

图 19. PWM Hysteresis Example

7.3.4.3 PWM Step Response

The LED current response due to a step change in the PWM input is approximately 2 ms to go from minimum LED current to maximum LED current.

7.3.4.4 PWM Timeout

The LM36923 PWM timeout feature turns off the boost output when the PWM is enabled and there is no PWM pulse detected. The timeout duration changes based on the PWM Sample Rate selected which results in a minimum supported PWM input frequency. The sample rate, timeout, and minimum supported PWM frequency are summarized in 表 5.

表 5. PWM Timeout and Minimum Supported PWM Frequency vs PWM Sample Rate

| SAMPLE RATE | TIMEOUT | MINIMUM SUPPORTED PWM FREQUENCY |
|-------------|----------|---------------------------------|
| 0.8 MHz | 25 msec | 48 Hz |
| 4 MHz | 3 msec | 400 Hz |
| 24 MHz | 0.6 msec | 2000 Hz |

7.3.5 LED Current Ramping

There are 8 programmable ramp rates available in the LM36923. These ramp rates are programmable as a time per step. Therefore, the ramp time from one current set-point to the next, depends on the number of code steps between currents and the programmed time per step. This ramp time to change from one brightness set-point (Code A) to the next brightness set-point (Code B) is given by:

$$\Delta t = \text{Ramp_rate} \times (\text{Code B} - \text{Code A} - 1) \quad (3)$$

For example, assume the ramp is enabled and set to 1 ms per step. Additionally, the brightness code is set to 0x444 (1092d). Then the brightness code is adjusted to 0x7FF (2047d). The time the current takes to ramp from the initial set-point to max brightness is:

$$\Delta t = \frac{1\text{ms}}{\text{step}} \times (0x7FF - 0x444 - 1) = 954\text{ms} \quad (4)$$

$$\Delta t = \frac{1\text{ms}}{\text{step}} \times (0x7FF - 0x444 - 1) = 954\text{ms} \quad (5)$$

7.3.6 Regulated Headroom Voltage

In order to optimize efficiency, current accuracy, and string-to-string matching the LED current sink regulated headroom voltage (VHR) varies with the target LED current. 图 20 details the typical variation of VHR with LED current. This allows for increased solution efficiency as the dropout voltage of the LED driver changes. Furthermore, in order to ensure that both current sinks remain in regulation whenever there is a mismatch in string voltages, the minimum headroom voltage between VLED1, VLED2, VLED3 becomes the regulation point for the boost converter. For example, if the LEDs connected to LED1 require 12 V, the LEDs connected to LED2 require 12.5 V, and the LEDs connected to LED3 require 13 V at the programmed current, then the voltage at LED1 is VHR + 1 V, the voltage at LED2 is VHR + 0.5 V, and the voltage at LED3 is regulated at VHR. In other words, the boost makes the cathode of the highest voltage LED string the regulation point.



图 20. LM36923 Typical Exponential Regulated Headroom Voltage vs Programmed LED Current

7.4 Device Functional Modes

Device Functional Modes describes the different operating modes and features available within the LM36923.

7.4.1 Brightness Control Modes

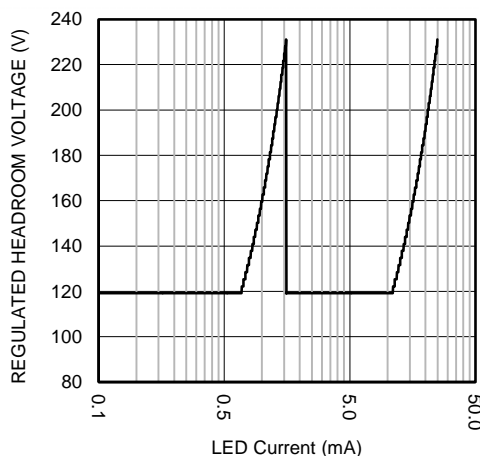
The LM36923 has 4 brightness control modes:

1. I²C Only (brightness mode 00)
2. PWM Only (brightness mode 01)
3. I²C × PWM with ramping only between I²C codes (brightness mode 10)
4. I²C × PWM with ramping between I²C × PWM changes (brightness mode 11)

7.4.1.1 I²C Only (Brightness Mode 00)

In brightness control mode 00 the I²C Brightness registers are in control of the LED current, and the PWM input is disabled. The brightness data (BRT) is the concatenation of the two brightness registers (3 LSBs) and (8 MSBs) (registers 0x18 and 0x19, respectively). The LED current only changes when the MSBs are written, meaning that to do a full 11-bit current change via I²C, first the 3 LSBs are written and then the 8 MSBs are written. In this mode the ramper only controls the time from one I²C brightness set-point to the next 图 21.

Device Functional Modes (接下页)



图 21. Brightness Control 00 (I²C Only)



1. At time t_0 the I²C Brightness Code is changed from 0x444 (1092d) to 0x7FF (2047d)
2. Ramp Rate programmed to 1ms/step
3. Mapping Mode set to Linear
4. $I_{LED_t0} = 1092 \times 12.213 \mu A = 13.337 \text{ mA}$
5. $I_{LED_t1} = 2047 \times 12.213 \mu A = 25 \text{ mA}$
6. $t_{RAMP} = (t_1 - t_0) = 1\text{ms/step} \times (2047 - 1092 - 1) = 954 \text{ ms}$

图 22. I²C Brightness Mode 00 Example (Ramp Between I²C Code Changes)

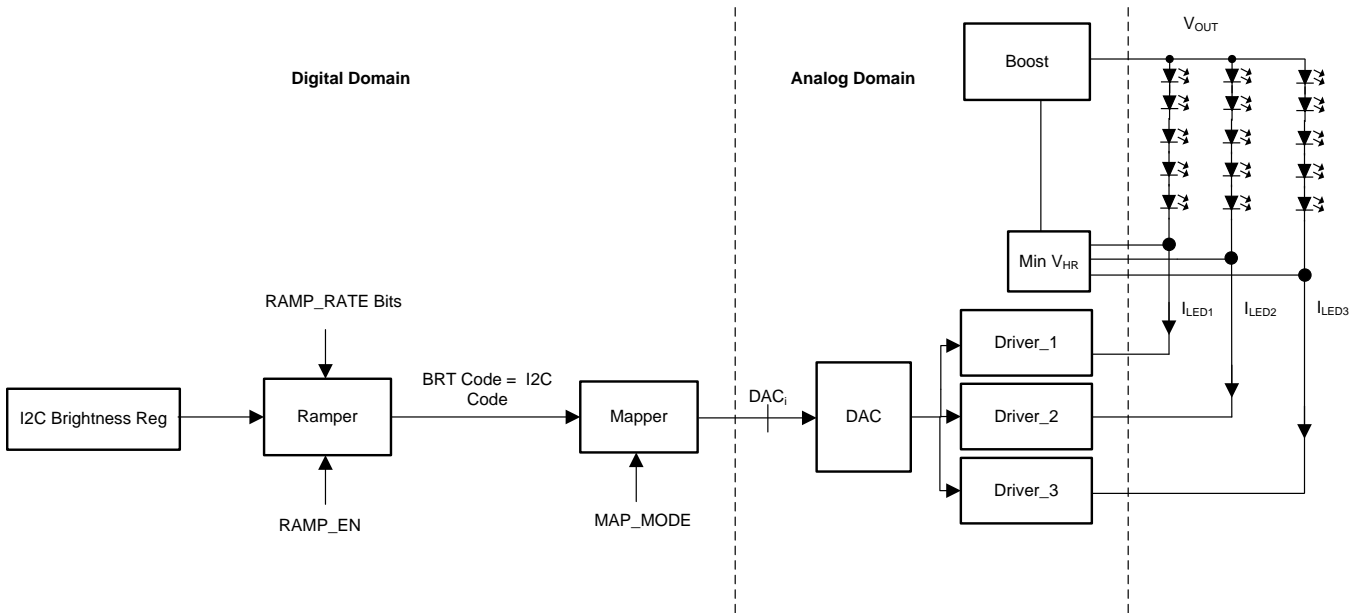
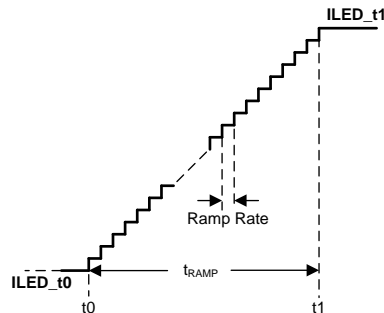
7.4.1.2 PWM Only (Brightness Mode 01)

In brightness mode 01, only the PWM input sets the brightness. The I²C code is ignored. The LM36923 samples the PWM input, determines the duty cycle and this measured duty cycle is translated into an 11-bit digital code. The resultant code is then applied to the internal ramper (see 图 23).

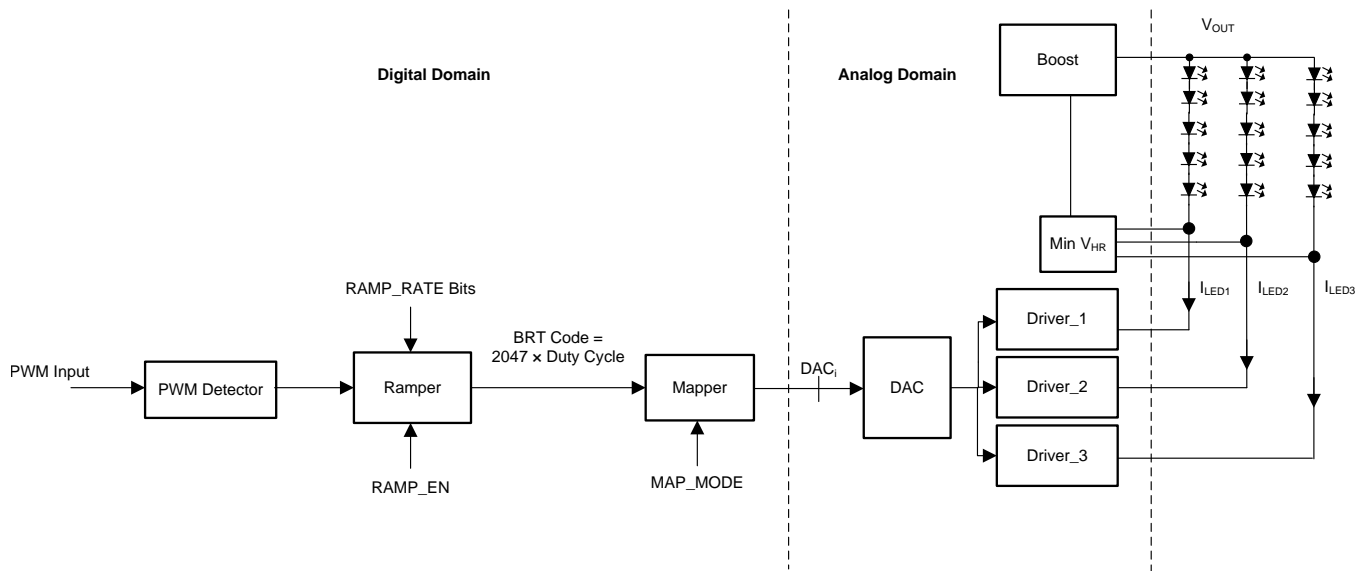
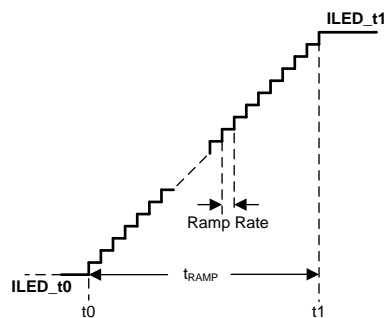
Device Functional Modes (接下页)

图 23. Brightness Control 01 (PWM Only)

1. At time t_0 the PWM duty cycle changed from 25% to 100%
2. Ramp Rate programmed to 1 ms/step
3. Mapping Mode set to Linear
4. $I_{LED_t0} = 25 \text{ mA} \times 0.25 = 6.25 \text{ mA}$
5. $I_{LED_t1} = 25 \text{ mA} \times 1 = 25 \text{ mA}$
6. $t_{RAMP} = (t_1 - t_0) = 1\text{ms/step} \times (2047 \times 1 - 2047 \times 0.25 - 1) = 1534 \text{ ms}$

图 24. Brightness Control Mode 01 Example (Ramp Between Duty Cycle Changes)
7.4.1.3 I²C + PWM Brightness Control (Multiply Then Ramp) Brightness Mode 10

In brightness control mode 10 the I²C Brightness register and the PWM input are both in control of the LED current. In this case the I²C brightness code is multiplied with the PWM duty cycle to produce an 11-bit code which is then sent to the ramper. In this mode ramping is achieved between I²C x PWM currents (see [图 25](#)).

Device Functional Modes (接下页)



图 25. Brightness Control 10 (I²C + PWM)



1. At time t0 the I²C Brightness code changed from 0x444 (1092d) to 0x7FF (2047d)
2. At time t0 the PWM duty cycle changed from 50% to 75%
3. Ramp Rate programmed to 1ms/step
4. Mapping Mode set to Linear
5. $I_{LED_t0} = 1092 \times 12.213 \mu A \times 0.5 = 6.668 \text{ mA}$
6. $I_{LED_t1} = 2047 \times 12.213 \mu A \times 0.75 = 18.75 \text{ mA}$
7. $t_{RAMP} = (t1 - t0) = 1\text{ms/step} \times (2047 \times 0.75 - 1092 \times 0.5 - 1) = 988 \text{ ms}$

图 26. Brightness Control Mode 10 Example (Multiply Duty Cycle then Ramp)

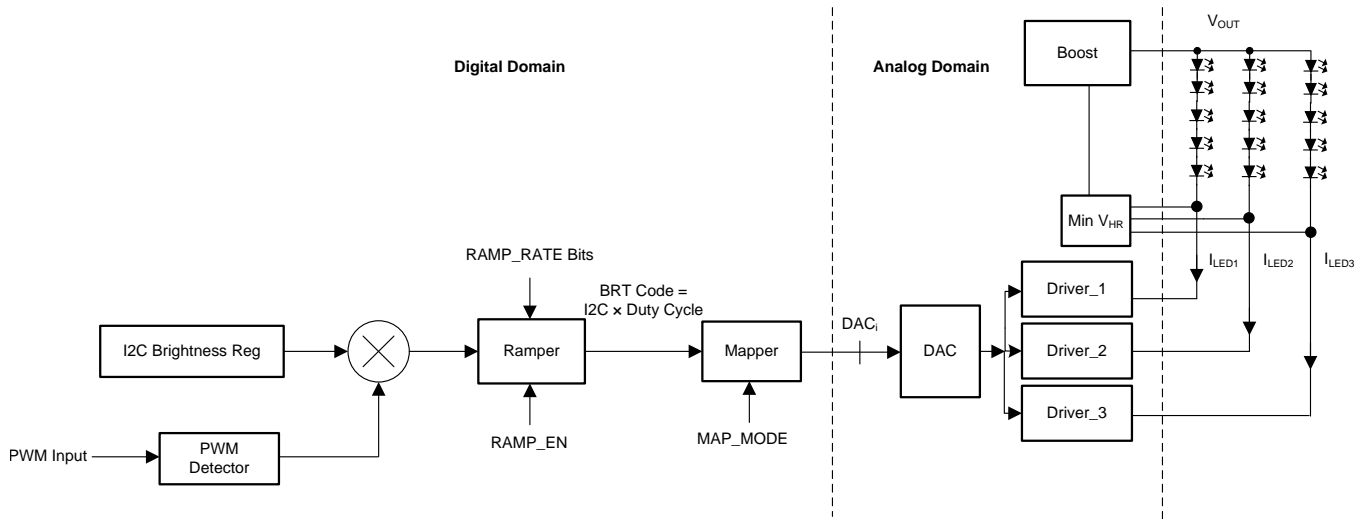
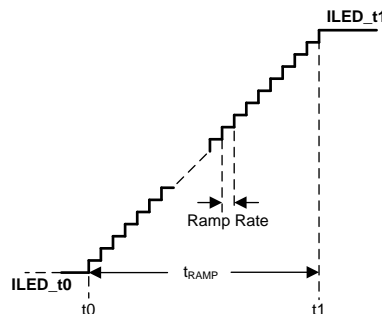
7.4.1.4 I²C + PWM Brightness Control (Ramp Then Multiply) Brightness Mode 11

In brightness control mode 11 both the I²C brightness code and the PWM duty cycle control the LED current. In this case the ramper only changes the time from one I²C brightness code to the next. The PWM duty cycle is multiplied with the I²C brightness code at the output of the ramper (see 图 27).

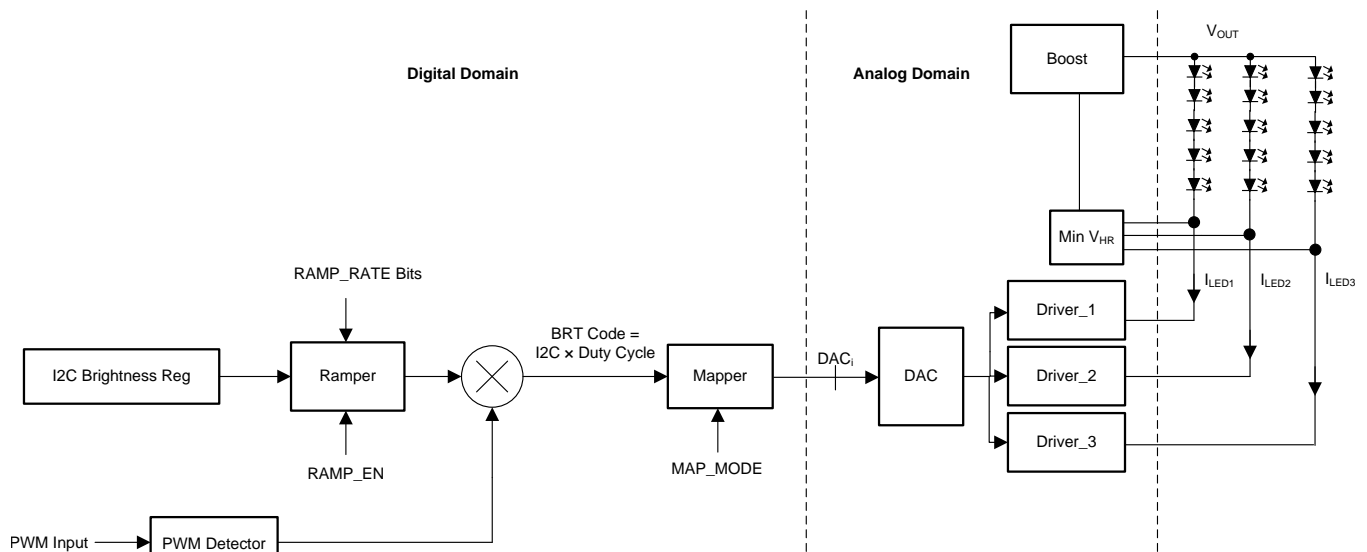
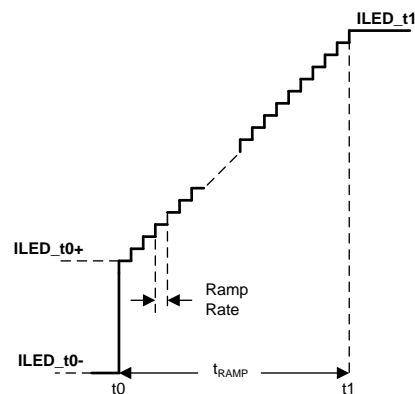
Device Functional Modes (接下页)

图 27. Brightness Control 11 (I²C + PWM)

1. At time t_0 the I²C Brightness code changed from 0x444 (1092d) to 0x7FF (2047d)
2. At time t_0 the PWM duty cycle changed from 50% to 75%
3. Ramp Rate programmed to 1 ms/step
4. Mapping Mode set to Linear
5. $I_{LED_t0-} = 1092 \times 12.213 \mu\text{A} \times 0.5 = 6.668 \text{ mA}$
6. $I_{LED_t0+} = 1092 \times 12.213 \mu\text{A} \times 0.75 = 10.002 \text{ mA}$
7. $t_{RAMP} = (t_1 - t_0) = 1 \text{ ms/step} \times (2047 - 1092 - 1) = 954 \text{ ms}$

图 28. Brightness Control Mode 11 Example (Ramp Current Then Multiply Duty Cycle)
7.4.2 Boost Switching Frequency

The LM36923 has two programmable switching frequencies: 500 kHz and 1 MHz. These are set via the Boost Control 1 register 0x13 bit [5]. Once the switching frequency is set, this nominal value can be shifted down by 12% via the boost switching frequency shift bit (register 0x13 bit[6]). Operation at 500 kHz is better suited for configurations which use a 22- μH inductor. Operation at 1 MHz is primarily beneficial when using a 10- μH inductor and where efficiency at maximum load current is more important. For maximum efficiency across the entire load current range the device incorporates an automatic frequency shift mode (see [Auto Switching Frequency](#)).

Device Functional Modes (接下页)

7.4.2.1 Minimum Inductor Select

The LM36923 can use inductors in the range of 10 μH to 22 μH . In order to optimize the converter response to changes in V_{IN} and load, the Min Inductor Select bit (register 0x13 bit[4]) should be selected depending on which value of inductance is chosen. For 22- μH inductors this bit should be set to 1. For less than 22 μH , this bit should be set to 0.

7.4.3 Auto Switching Frequency

To take advantage of frequency vs load dependent losses, the LM36923 has the ability to automatically change the boost switching frequency based on the magnitude of the load current. In addition to the register programmable switching frequencies of 500 kHz and 1 MHz, the auto-frequency mode also incorporates a low frequency selection of 250 kHz. It is important to note that the 250-kHz frequency is only accessible in auto-frequency mode and has a maximum boost duty cycle (D_{MAX}) of 50%.

Auto-frequency mode operates by using 2 programmable registers (Auto Frequency High Threshold (register 0x15) and Auto Frequency Low Threshold (0x16)). The high threshold determines the switchover from 1 MHz to 500 kHz. The low threshold determines the switchover from 500 kHz to 250 kHz. Both the High and Low Threshold registers take an 8-bit code which is compared against the 8 MSB of the brightness register (register 0x19). 表 6 details the boundaries for this mode.

表 6. Auto Switching Frequency Operation

| BRIGHTNESS CODE MSBs (Register 0x19 bits[7:0]) | BOOST SWITCHING FREQUENCY |
|---|-------------------------------------|
| < Auto Frequency Low Threshold (register 15 Bits[7:0]) | 250 kHz ($D_{\text{MAX}} = 50\%$) |
| > Auto Frequency Low Threshold (Register 15 Bits[7:0]) or < Auto Frequency High Threshold (Register 14 Bits[7:0]) | 500 kHz |
| \geq Auto Frequency High Threshold (register 14 Bits[7:0]) | 1 MHz |

Automatic-frequency mode is enabled whenever there is a non-zero code in either the Auto-Frequency High or Auto-Frequency Low registers. To disable the auto-frequency shift mode, set both registers to 0x00. When automatic-frequency select mode is disabled, the switching frequency operates at the programmed frequency (Register 0x13 bit[5]) across the entire LED current range. 表 7 provides a guideline for selecting the auto frequency 250-kHz threshold setting, the actual setting needs to be verified in the application.

表 7. Auto Frequency 250-kHz Threshold Settings

| CONDITION ($V_{\text{f}}=3.2\text{ V}$, $I_{\text{LED}}=25\text{ mA}$) | INDUCTOR (μH) | RECOMMENDED AUTO FREQUENCY LOW THRESHOLD MAXIMUM VALUE (NO SHIFT) | OUTPUT POWER AT AUTO FREQUENCY SWITCHOVER (W) |
|---|-------------------------------|---|---|
| 3 x 4 LEDs | 10 | 0x17 | 0.079 |
| 3 x 5 LEDs | 10 | 0x15 | 0.089 |
| 3 x 6 LEDs | 10 | 0x13 | 0.097 |
| 3 x 7 LEDs | 10 | 0x11 | 0.101 |
| 3 x 8 LEDs | 10 | 0x0f | 0.102 |

7.4.4 Backlight Adjust Input (BL_ADJ)

Driving BL_ADJ to a logic high voltage provides a way to quickly reduce the LED current during system high-power conditions such as camera flash, PA transmit, or other high battery-current conditions. The adjusted current target is programmable via register 0x17 bits[7:0]. Only the MSBs of the brightness code are adjustable. Additionally, the BL_ADJ input only decreases the current from the initial target. If the initial target is > the adjusted current then nothing happens — the LED current remains at its current value. 图 30 details the BL_ADJ operation.

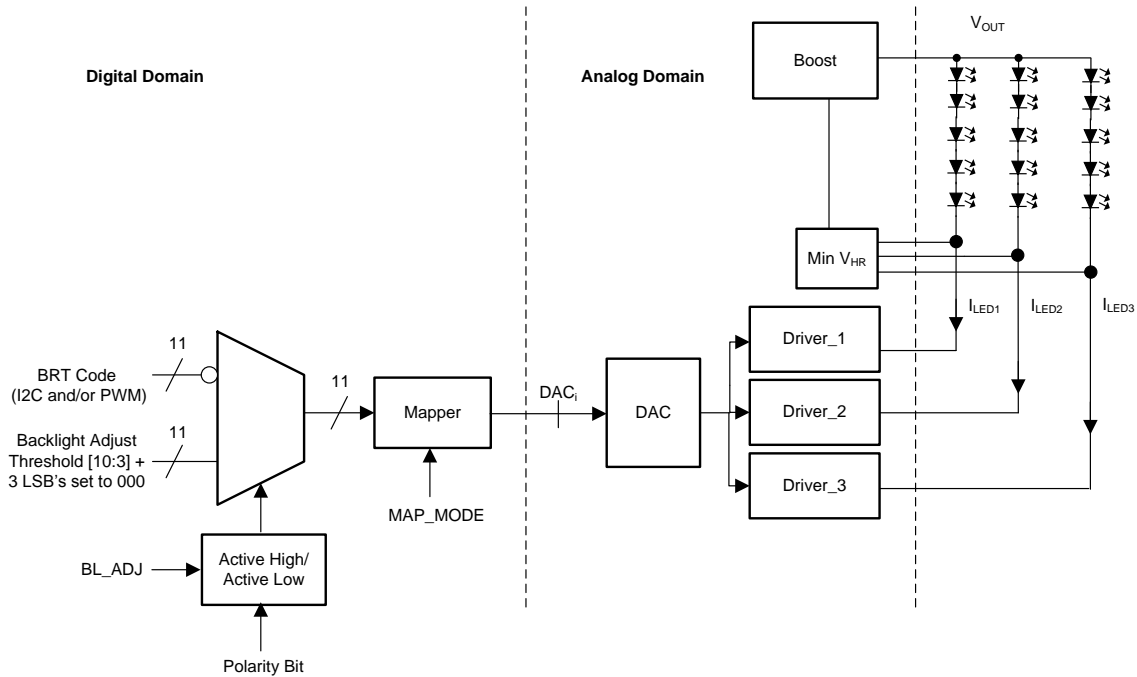
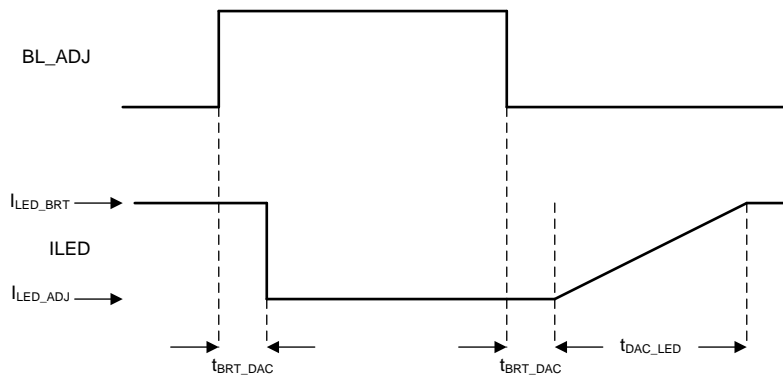
图 29. Backlight Adjust Operation

LED Current operates at an initial target I_{LED_BRT} which is set by either I²C or PWM (or both).

When the BL_ADJ input is driven to a logic high the LM36923's brightness code at the Mapper input has the MSBs set to the BL_ADJ Threshold and the LSBs set to 000.

I_{LED} steps down to the new target current in $< 50 \mu s$.

When BL_ADJ is forced low the LED current returns to the initial brightness target.

图 30. Backlight Adjust Timing

7.4.4.1 Back-Light Adjust Input Polarity

The BL_ADJ input can have either active high or active low polarity. With active high polarity (default), driving the BL_ADJ input high forces the LED current to the BL_ADJ low target current. With active low polarity, driving the BL_ADJ input low forces the LED current to the BL_ADJ low target current. The polarity is set via bit 0 in register 11.

7.4.5 Fault Protection/Detection

7.4.5.1 Overvoltage Protection (OVP)

The LM36923 provides four OVP thresholds (17 V, 21 V, 25 V, and 29 V). The OVP circuitry monitors the boost output voltage (V_{OUT}) and protects OUT and SW from exceeding safe operating voltages in case of open load conditions or in the event the LED string voltage requires more voltage than the programmed OVP setting. The OVP thresholds are programmed in register 13 bits[3:2]. The operation of OVP differentiates between two overvoltage conditions and responds differently as outlined below:

7.4.5.1.1 Case 1 OVP Fault Only (OVP Threshold Hit and All Enabled Current Sink Inputs > 40 mV)

In steady-state operation with V_{OUT} near the OVP threshold a rapid change in V_{IN} or brightness code can result in a momentary transient excursion of V_{OUT} above the OVP threshold. In this case the boost circuitry is disabled until V_{OUT} drops below $OVP - \text{hysteresis}$ (1 V). Once this happens the boost is re-enabled and steady state regulation continues. If V_{OUT} remains above the OVP threshold for > 1 ms the OVP Flag is set (register 0x1F bit[0]).

7.4.5.1.2 Case 2a OVP Fault and Open LED String Fault (OVP Threshold Occurrence and Any Enabled Current Sink Input \leq 40 mV)

When any of the enabled LED strings is open the boost converter tries to drive V_{OUT} above OVP and at the same time the open string(s) current sink headroom voltage(s) (LED1, LED2, LED3) drop to 0. When the LM36923 detects three occurrences of $V_{OUT} > OVP$ and any enabled current sink input (V_{LED1} or V_{LED2} , V_{LED3}) \leq 40 mV, the OVP Fault flag is set (register 0x1F bit[0]), and the LED Open Fault flag is set (register 0x1F bit[4]).

7.4.5.1.3 Case 2b OVP Fault and Open LED String Fault (OVP Threshold Duration and Any Enabled Current Sink Input \leq 40 mV)

When any of the enabled LED strings is open the boost converter tries to drive V_{OUT} above OVP and at the same time the open string(s) current sink headroom voltage(s) (LED1, LED2, LED3) drop to 0. When the LM36923 detects $V_{OUT} > OVP$ for > 1 msec and any enabled current sink input (V_{LED1} or V_{LED2} , V_{LED3}) \leq 40 mV, the OVP Fault flag is set (register 0x1F bit[0]), and the LED Open Fault flag is set (register 0x1F bit[4]).

7.4.5.1.4 OVP/LED Open Fault Shutdown

The LM36923 has the option of shutting down the device when the OVP flag is set. This option can be enabled or disabled via register 0x1E bit[0]. When the shutdown option is disabled the fault flag is a report only. When the device is shut down due to an OVP/LED String Open fault, the fault flags register must be read back before the LM36923 can be re-enabled.

7.4.5.1.5 Testing for LED String Open

The procedure for detecting an open in a LED string is:

- Apply power to the LM36923.
- Enable all LED strings (Register 0x10 = 0x0F).
- Set maximum brightness (Register 0x18 = 0x07 and Register 0x19 = 0xFF).
- Set the brightness control (Register 0x11 = 0x00).
- Open LED1 string.
- Wait 4 msec.
- Read LED open fault (Register 0x1F).
- If bit[4] = 1, then a LED open fault condition has been detected.
- Connect LED1 string.
- Repeat the procedure for the other LED strings.

7.4.5.2 LED String Short Fault

The LM36923 can detect an LED string short fault. This happens when the voltage between V_{IN} and any enabled current sink input has dropped below (1.5 V). This test can only be performed on one LED string at a time. Performing this test with more than one LED string enabled can result in a faulty reading. The procedure for detecting a short in a LED string is:

- Apply power to the LM36923.
- Enable only LED1 string (Register 0x10 = 0x03).
- Enable short fault (Register 0x1E = 0x01).
- Set maximum brightness (Register 0x18 = 0x07 and Register 0x19 = 0xFF).
- Set the brightness control (Register 0x11 = 0x00).
- Wait 4 msec.
- Read LED short fault (Register 0x1F).
- If bit[3] = 1, then a LED short fault condition has been detected.
- Set chip enable and LED string enable low (Register 0x10 = 0x00).
- Repeat the procedure for the other LED strings.

7.4.5.3 Overcurrent Protection (OCP)

The LM36923 has 4 selectable OCP thresholds (750 mA, 1000 mA, 1250 mA, and 1500 mA). These are programmable in register 0x13 bits[1:0]. The OCP threshold is a cycle-by-cycle current limit and is detected in the internal low-side NFET. Once the threshold is hit the NFET turns off for the remainder of the switching period.

7.4.5.3.1 OCP Fault

If enough overcurrent threshold events occur, the OCP Flag (register 0x1F bit[1]) is set. To avoid transient conditions from inadvertently setting the OCP Flag, a pulse density counter monitors OCP threshold events over a 128- μ s period. If 8 consecutive 128- μ s periods occur where the pulse density count has found 2 or more OCP events, then the OCP Flag is set.

During device start-up and during brightness code changes, there is a 4-ms blank time where OCP events are ignored. As a result, if the device starts up in an overcurrent condition there is an approximate 5-ms delay before the OCP Flag is set.

7.4.5.3.2 OCP Shutdown

The LM36923 has the option of shutting down the device when the OCP flag is set. This option can be enabled or disabled via register 0x1E bit[1]. When the shutdown option is disabled, the fault flag is a report only. When the device is shut down due to an OCP fault, the fault flags register must be read back before the LM36923 can be re-enabled.

7.4.5.4 Device Overtemperature (TSD)

Thermal shutdown (TSD) is triggered when the device die temperature reaches 135°C. When this happens the boost stops switching, and the TSD Flag (register 0x1F bit[2]) is set. The boost automatically starts up again when the die temperature cools down to 120°C.

7.4.5.4.1 Overtemperature Shutdown

The LM36923 has the option of shutting down the device when the TSD flag is set. This option can be enabled or disabled via register 0x1E bit[2]. When the shutdown option is disabled the fault flag is a report only. When the device is shutdown due to a TSD fault, the Fault Flags register must be read back before the LM36923 can be re-enabled.

7.5 Programming

7.5.1 I²C Interface

7.5.1.1 Start and Stop Conditions

The LM36923 is configured via an I²C interface. START (S) and STOP (P) conditions classify the beginning and the end of the I²C session [图 31](#). A START condition is defined as SDA transitioning from HIGH to LOW while SCL is HIGH. A STOP condition is defined as SDA transitioning from LOW to HIGH while SCL is HIGH. The I²C master always generates the START and STOP conditions. The I²C bus is considered busy after a START condition and free after a STOP condition. During the data transmission the I²C master can generate repeated START conditions. A START and a repeated START conditions are equivalent function-wise. The data on SDA must be stable during the HIGH period of the clock signal (SCL). In other words, the state of SDA can only be changed when SCL is LOW.



图 31. I²C Start and Stop Conditions

7.5.1.2 I²C Address

The 7-bit chip address for the LM36923 is (0x36). After the START condition the I²C master sends the 7-bit chip address followed by an eighth bit read or write (R/W). R/W = 0 indicates a WRITE, and R/W = 1 indicates a READ. The second byte following the chip address selects the register address to which the data is written. The third byte contains the data for the selected register.

7.5.1.3 Transferring Data

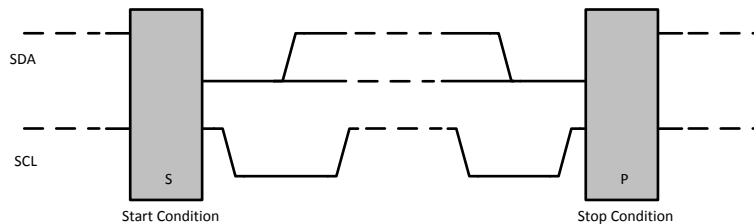
Every byte on the SDA line must be eight bits long with the most significant bit (MSB) transferred first. Each byte of data must be followed by an acknowledge bit (ACK). The acknowledge related clock pulse, (9th clock pulse), is generated by the master. The master then releases SDA (HIGH) during the 9th clock pulse. The LM36923 pulls down SDA during the 9th clock pulse, signifying an acknowledge. An acknowledge is generated after each byte has been received.

7.5.1.4 Register Programming

For glitch free operation, the following bits and/or registers should only be programmed while the LED Enable bits are 0 (Register 0x10, Bit [3:1] = 0) and Device Enable bit is 1 (Register 0x10, Bit[0] = 1) :

1. Register 0x11 Bit[7] (Mapping Mode)
2. Register 0x11 Bits[6:5] (Brightness Mode)
3. Register 0x11 Bit[4] (Ramp Enable)
4. Register 0x11 Bit[3:1] (Ramp Rate)
5. Register 0x12 Bits[7:6] (PWM Sample Rate)
6. Register 0x12 Bits[5] (PWM Polarity)
7. Register 0x12 Bit[3:2] (PWM Hysteresis)
8. Register 0x12 Bit[3:2] (PWM Pulse Filter)
9. Register 0x15 (auto frequency high threshold)
10. Register 0x16 (auto frequency low threshold)
11. Register 0x17 (back-light adjust threshold)

7.6 Register Maps

Note: Read of Reserved (R) or Write Only register returns 0

表 8. Revision (0x00)

| Bits [7:4] | Bits [3:0] |
|------------|---------------|
| R | Revision Code |

表 9. Software Reset (0x01)

| Bits [7:1] | Software Reset Bit [0] |
|------------|---|
| R | 0 = Normal Operation 1 = Device Reset (automatically resets back to 0) |

表 10. Enable (0x10)

| Bits [7:4] | LED3 Enable Bit [3] | LED2 Enable Bit [2] | LED1 Enable Bit [1] | Device Enable Bit [0] |
|--|---------------------------------------|---------------------------------------|---------------------------------------|---------------------------------------|
| R | 0 = Disabled 1 = Enabled (Default) | 0 = Disabled 1 = Enabled (Default) | 0 = Disabled 1 = Enabled (Default) | 0 = Disabled 1 = Enabled (Default) |
| NOTE: When the Device Enable (Bit [0]) is set high the following registers/bits are set to the default value: Register 0x11 Bit[0], Register 0x12 Bits[7:0]. | | | | |

表 11. Brightness Control (0x11)

| Mapping Mode Bit [7] | Brightness Mode Bits [6:5] | Ramp Enable Bits [4] | Ramp Rate Bit [3:1] | BL_ADJ Polarity Bits [0] |
|---|---|---|---|---|
| 0 = Linear (default) 1 = Exponential | 00 = Brightness Register Only 01 = PWM Duty Cycle Only 10 = Multiply Then Ramp (Brightness Register x PWM) 11 = Ramp Then Multiply (Brightness Register x PWM) (default) | 0 = Ramp Disabled (default) 1 = Ramp Enabled | 000 = 0.125 ms/step (default) 001 = 0.250 ms/step 010 = 0.5 ms/step 011 = 1 ms/step 100 = 2 ms/step 101 = 4 ms/step 110 = 8 ms/step 111 = 16 ms/step | 0 = Active Low 1 = Active High (default) |

表 12. PWM Control (0x12)

| PWM Sample Rate Bit [7:6] | PWM Input Polarity Bit [5] | PWM Hysteresis Bits [4:2] | PWM Pulse Filter Bit [1:0] |
|---|---|--|---|
| 00 = 800 kHz 01 = 4 MHz (default) 1X = 24 MHz | 0 = Active Low 1 = Active High (default) | 000 = None 001 = 1 LSB 010 = 2 LSBs 011 = 3 LSBs 100 = 4 LSBs (default) 101 = 5 LSBs 110 = 6 LSBs 111 = N/A | 00 = No Filter 01 = 100 ns 10 = 150 ns 11 = 200 ns (default) |

表 13. Boost Control 1 (0x13)

| Reserved Bit [7] | Boost Switching Frequency Shift Bit [6] | Boost Switching Frequency Select Bit [5] | Minimum Inductor Select Bit [4] | Overshoot Protection (OVP) Bits [3:2] | Current Limit (OCP) Bits [1:0] |
|------------------|--|--|--|--|---|
| N/A | 0 = -12% Shift 1 = No Shift (default) | 0 = 500 kHz 1 = 1 MHz (default) | 0 = 10 μ H (default) 1 = 22 μ H | 00 = 17 V 01 = 21 V 10 = 25 V 11 = 29 V (default) | 00 = 750 mA 01 = 1000 mA 10 = 1250 mA 11 = 1500 mA (default) |

表 14. Auto Frequency High Threshold (0x15)

| Auto Frequency High Threshold (500 kHz to 1000 kHz) Bits [7:0] |
|---|
| Compared against the 8 MSBs of 11-bit brightness code (default = 00000000). |

表 15. Auto Frequency Low Threshold (0x16)

| Auto Frequency High Threshold (250 kHz to 500 kHz) Bits [7:0] |
|---|
| Compared against the 8 MSBs of 11-bit brightness code (default = 00000000). |

表 16. Back Light Adjust Threshold (0x17)

| Back Light Adjust Threshold (Brightness Ceiling) Bits [7:0] |
|--|
| When BL_ADJ Input is driven high the MSBs of the brightness code are forced to the code in this register (default = 00000000). |

表 17. Brightness Register LSBs (0x18)

| Bits [7:3] | I ² C Brightness Code (LSB) Bits [2:0] |
|------------|---|
| R | This is the lower 3 bits of the 11-bit brightness code (default = 111). |

表 18. Brightness Register MSBs (0x19)

| I ² C Brightness Code (MSB) Bits [7:0] |
|--|
| This is the upper 8 bits of the 11-bit brightness code (default = 11111111). |

表 19. Fault Control (0x1E)

| Reserved Bits [7:4] | LED Short Fault Enable Bit [3] | TSD Shutdown Disable Bit [2] | OCP Shutdown Disable Bit [1] | OVP/LED Open Shutdown Disable Bit [0] |
|---------------------|---|--|--|--|
| R | 0 = LED Short Fault Detection is disabled (default) 1 = LED Short Fault Detection is enabled | 0 = When the TSD Flag is set, the device is forced into shutdown. 1 = No shutdown (default) | 0 = When the OCP Flag is set, the device is forced into shutdown. 1 = No shutdown (default) | 0 = When the OVP Flag is set, the device is forced into shutdown. 1 = No shutdown (default) |

表 20. Fault Flags (0x1F)

| Reserved Bits [7:5] | LED Open Fault Bit [4] | LED Short Fault Bit [3] | TSD Fault Bit [2] | OCP Fault Bit [1] | OVP Fault Bit [0] |
|---------------------|---------------------------|-------------------------|----------------------------|-------------------------|------------------------------|
| R | 1 = LED String Open Fault | 1 = LED Short Fault | 1 = Thermal Shutdown Fault | 1 = Current Limit Fault | 1 = Output Overvoltage Fault |

8.2.2 Detailed Design Procedure

表 21. Typical Application Component List

| CONFIGURATION | L1 | D1 | C _{OUT} |
|---------------|--------------------------------------|--------------|---------------------|
| 3p7s, 3p8s | VLF504012MT-100M VLF504012MT-150M | NSR0530P2T5G | C2012X7R1H105K085AC |
| 3p6s | VLF504012MT-220M | NSR0530P2T5G | C2012X7R1H105K085AC |
| 3p5s | VLF403210MT-100M | NSR0530P2T5G | C2012X7R1H105K085AC |
| 3p4s | VLF302510MT-100M | NSR0530P2T5G | C2012X7R1H105K085AC |

8.2.2.1 Component Selection

8.2.2.1.1 Inductor

The LM36923 requires a typical inductance in the range of 10 μH to 22 μH. When selecting the inductor, ensure that the saturation rating for the inductor is high enough to accommodate the peak inductor current of the application (I_{PEAK}) given in the inductor datasheet. The peak inductor current occurs at the maximum load current, the maximum output voltage, the minimum input voltage, and the minimum switching frequency setting. Also, the peak current requirement increases with decreasing efficiency. I_{PEAK} can be estimated using 公式 6:

$$I_{PEAK} = \frac{V_{OUT} \times I_{OUT}}{V_{IN} \times \eta} + \frac{V_{IN}}{2 \times f_{SW} \times L} \times \left(1 + \frac{V_{IN} \times \eta}{V_{OUT}}\right) \quad (6)$$

Also, the peak current calculated above is different from the peak inductor current setting (I_{SAT}). The NMOS switch current limit setting (I_{CL_MIN}) must be greater than I_{PEAK} from 公式 6 above.

8.2.2.1.2 Output Capacitor

The LM36923 requires a ceramic capacitor with a minimum of 0.4 μF of capacitance at the output, specified over the entire range of operation. This ensures that the device remains stable and oscillation free. The 0.4 μF of capacitance is the minimum amount of capacitance, which is different than the value of capacitor. Capacitance would take into account tolerance, temperature, and DC voltage shift.

表 22 lists possible output capacitors that can be used with the LM36923. 图 33 shows the DC bias of the four TDK capacitors. The useful voltage range is determined from the effective output voltage range for a given capacitor as determined by 公式 7:

$$DC \text{ Voltage Derating} \geq \frac{0.38\mu F}{(1 - Tol) \times (1 - Temp_co)} \quad (7)$$

表 22. Recommended Output Capacitors

| PART NUMBER | MANUFACTURER | CASE SIZE | VOLTAGE RATING (V) | NOMINAL CAPACITANCE (μF) | TOLERANCE (%) | TEMPERATURE COEFFICIENT (%) | RECOMMENDED MAX OUTPUT VOLTAGE (FOR SINGLE CAPACITOR) |
|---------------------|--------------|-----------|--------------------|--------------------------|---------------|-----------------------------|---|
| C2012X5R1H105K085AB | TDK | 0805 | 50 | 1 | ±10 | ±15 | 22 |
| C2012X5R1H225K085AB | TDK | 0805 | 50 | 2.2 | ±10 | ±15 | 24 |
| C1608X5R1V225K080AC | TDK | 0603 | 35 | 2.2 | ±10 | ±15 | 12 |
| C1608X5R1H105K080AB | TDK | 0603 | 50 | 1 | ±10 | ±15 | 15 |

For example, with a 10% tolerance, and a 15% temperature coefficient, the DC voltage derating must be $\geq 0.38 / (0.9 \times 0.85) = 0.5 \mu F$. For the C1608X5R1H225K080AB (0603, 50-V) device, the useful voltage range occurs up to the point where the DC bias derating falls below 0.523 μF, or around 12 V. For configurations where V_{OUT} is $> 15 V$, two of these capacitors can be paralleled, or a larger capacitor such as the C2012X5R1H105K085AB must be used.



图 33. DC Bias Derating for 0805 Case Size and 0603 Case Size 35-V and 50-V Ceramic Capacitors

8.2.2.1.3 Input Capacitor

The input capacitor in a boost is not as critical as the output capacitor. The input capacitor primary function is to filter the switching supply currents at the device input and to filter the inductor current ripple at the input of the inductor. The recommended input capacitor is a 2.2-µF ceramic (0402, 10-V device) or equivalent.

8.2.3 Application Curves

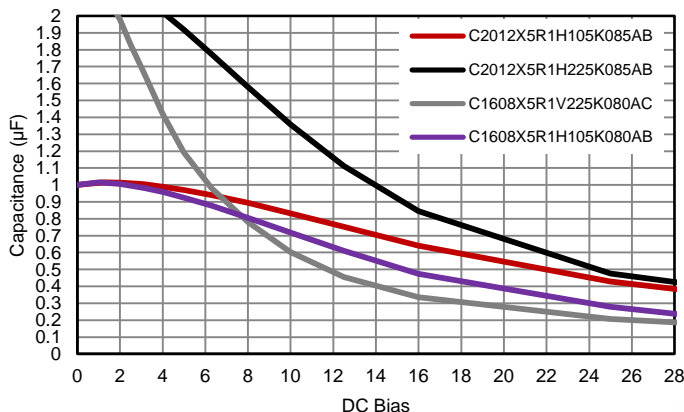
L1 = 10 µH (VLF403212-100M) or 22 µH (VLF504015-220M) as noted in graphs, D1 = NSR530P2T5G, LEDs are Rohm SML312WBCW1, temperature = 25°C, V_{IN} = 3.7 V, unless otherwise noted.



图 34. Boost Efficiency vs Series LEDs



图 35. Boost Efficiency vs Series LEDs

L1 = 10 μ H (VLF403212-100M) or 22 μ H (VLF504015-220M) as noted in graphs, D1 = NSR530P2T5G, LEDs are Rohm SML312WBCW1, temperature = 25°C, V_{IN} = 3.7 V, unless otherwise noted.

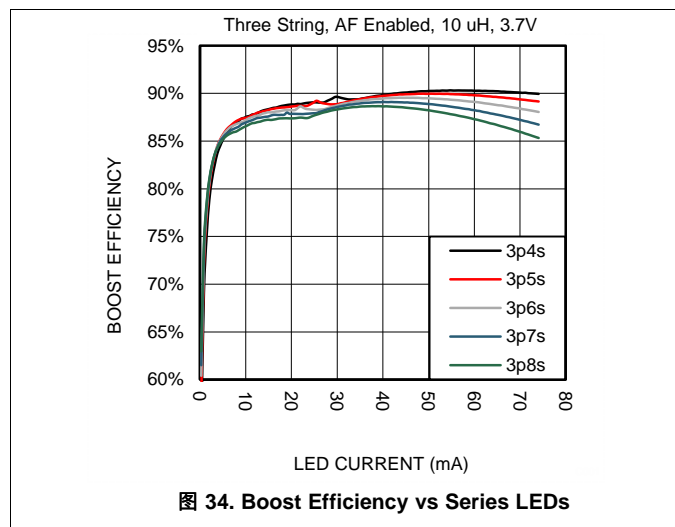

L1 = 10 μ H (VLF403212-100M) or 22 μ H (VLF504015-220M) as noted in graphs, D1 = NSR530P2T5G, LEDs are Rohm SML312WBCW1, temperature = 25°C, V_{IN} = 3.7 V, unless otherwise noted.

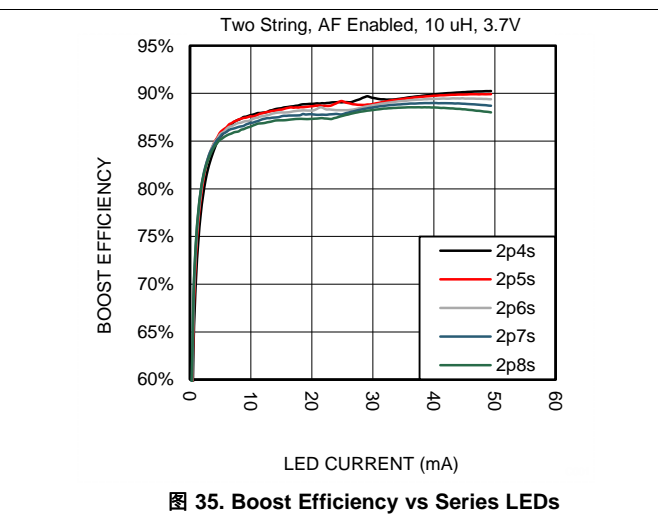
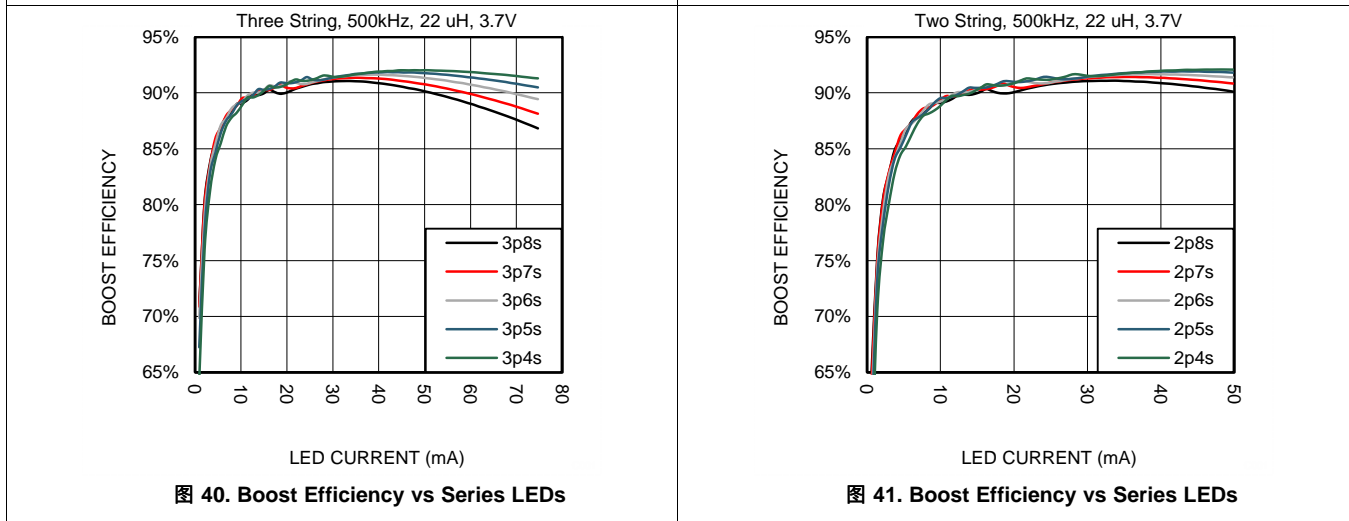
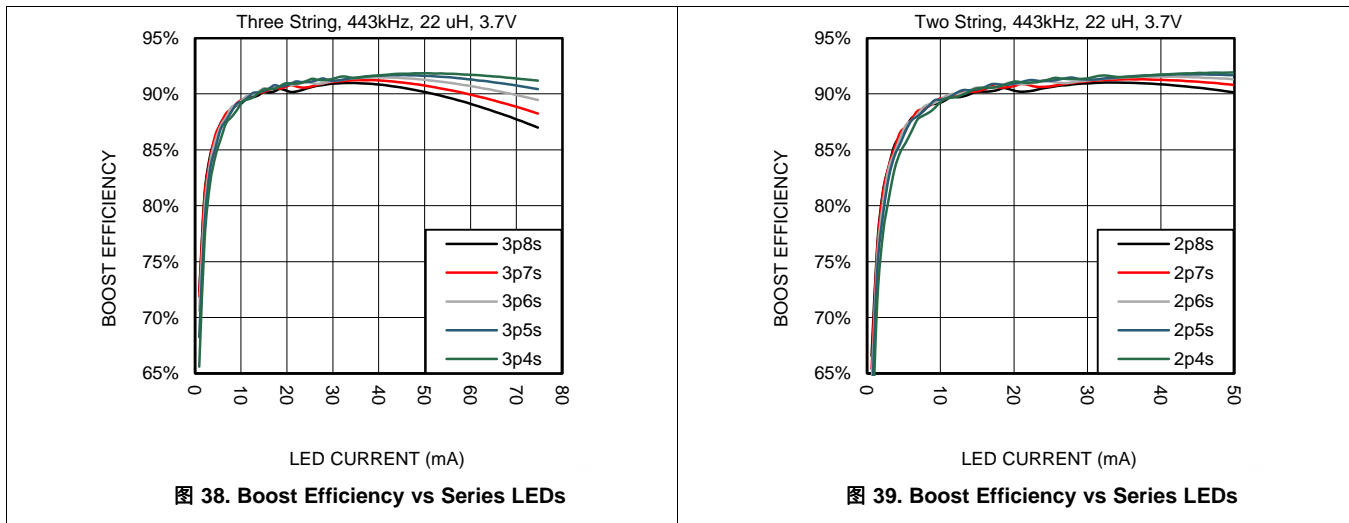
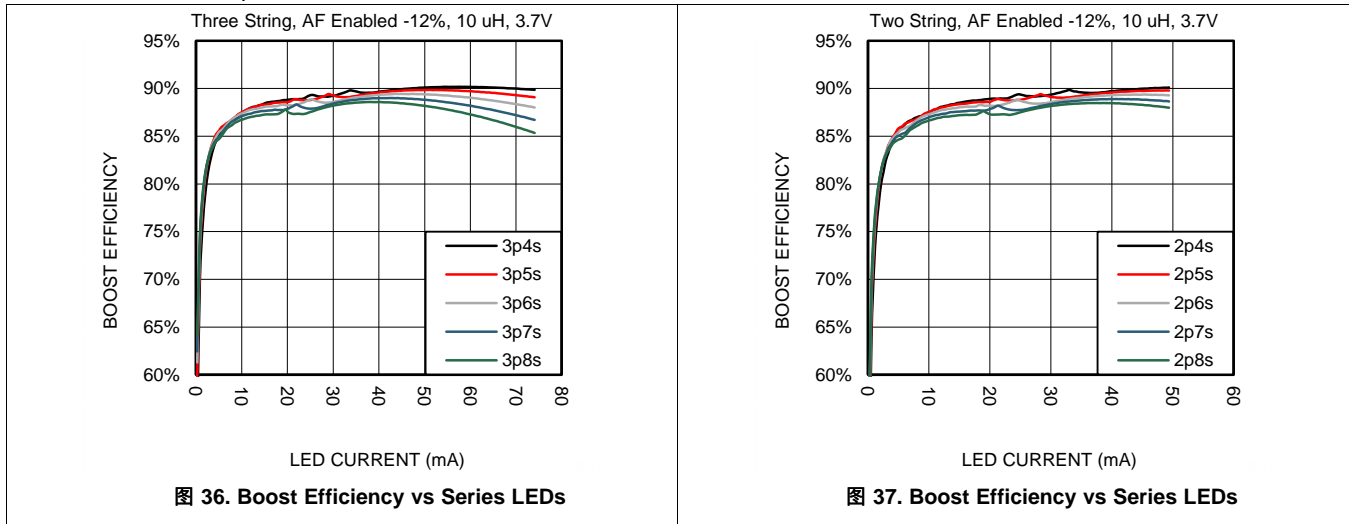

图 42. Boost Efficiency vs Series LEDs



图 43. Boost Efficiency vs Series LEDs

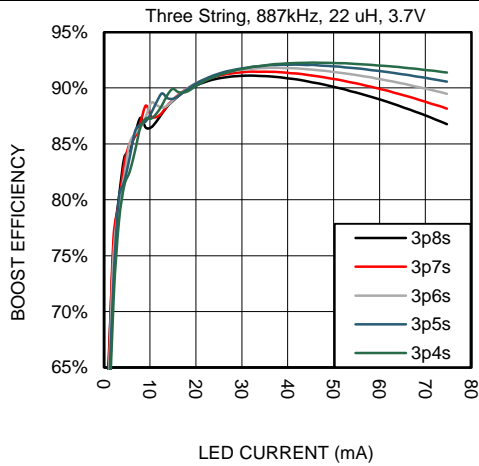

图 44. Boost Efficiency vs Series LEDs

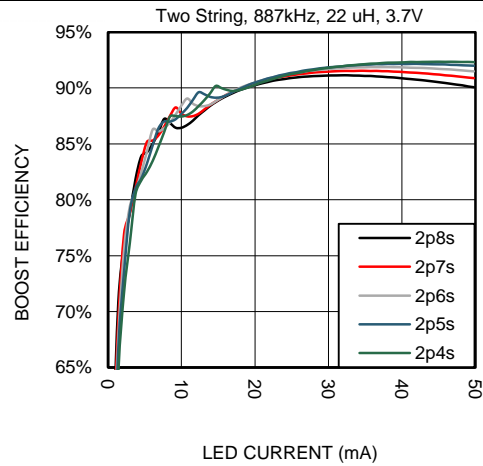

图 45. Boost Efficiency vs Series LEDs

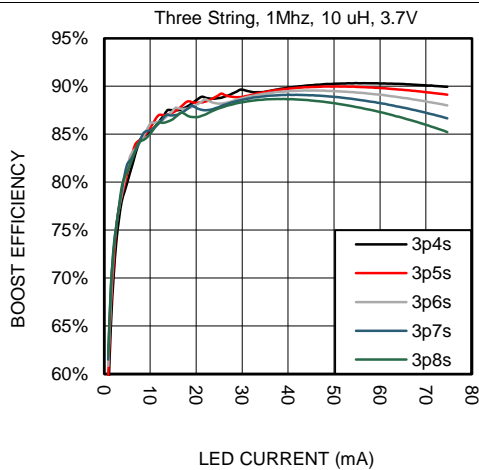

图 46. Boost Efficiency vs Series LEDs

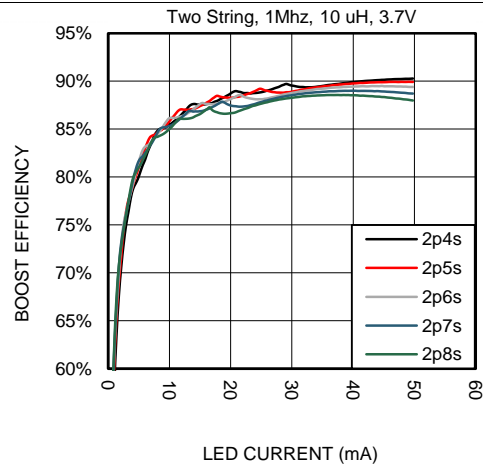

图 47. Boost Efficiency vs Series LEDs

L1 = 10 μ H (VLF403212-100M) or 22 μ H (VLF504015-220M) as noted in graphs, D1 = NSR530P2T5G, LEDs are Rohm SML312WBCW1, temperature = 25°C, V_{IN} = 3.7 V, unless otherwise noted.

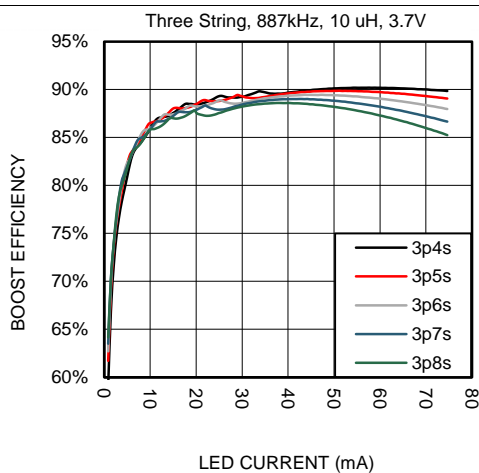

L1 = 10 μ H (VLF403212-100M) or 22 μ H (VLF504015-220M) as noted in graphs, D1 = NSR530P2T5G, LEDs are Rohm SML312WBCW1, temperature = 25°C, V_{IN} = 3.7 V, unless otherwise noted.

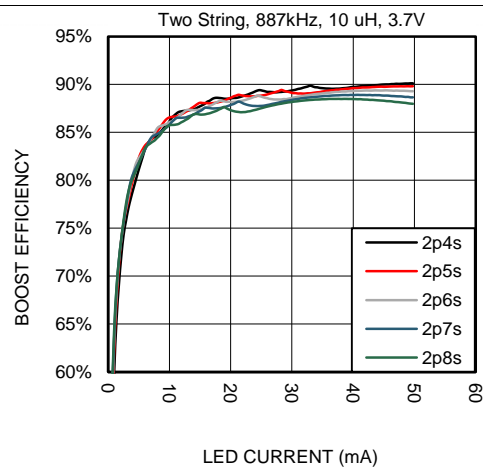
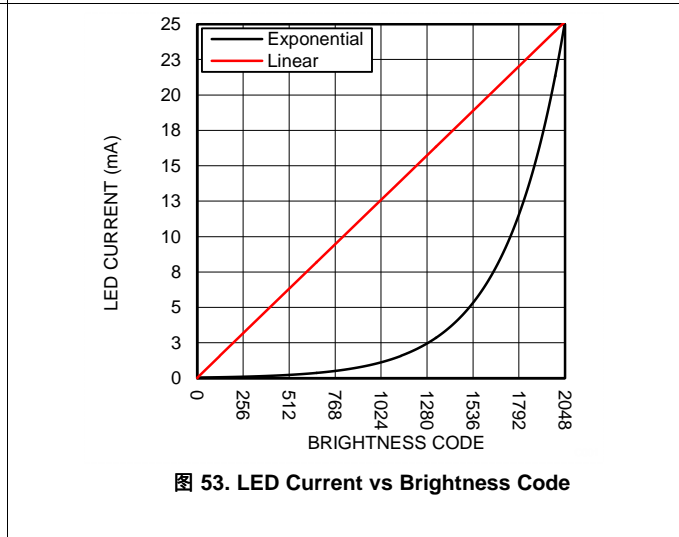
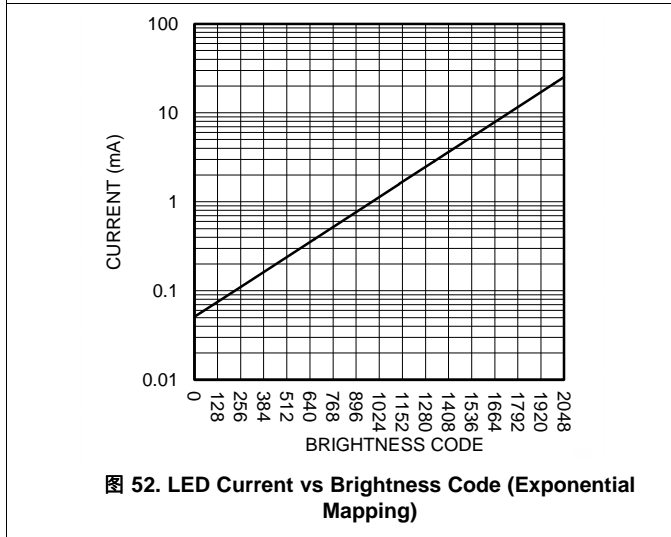
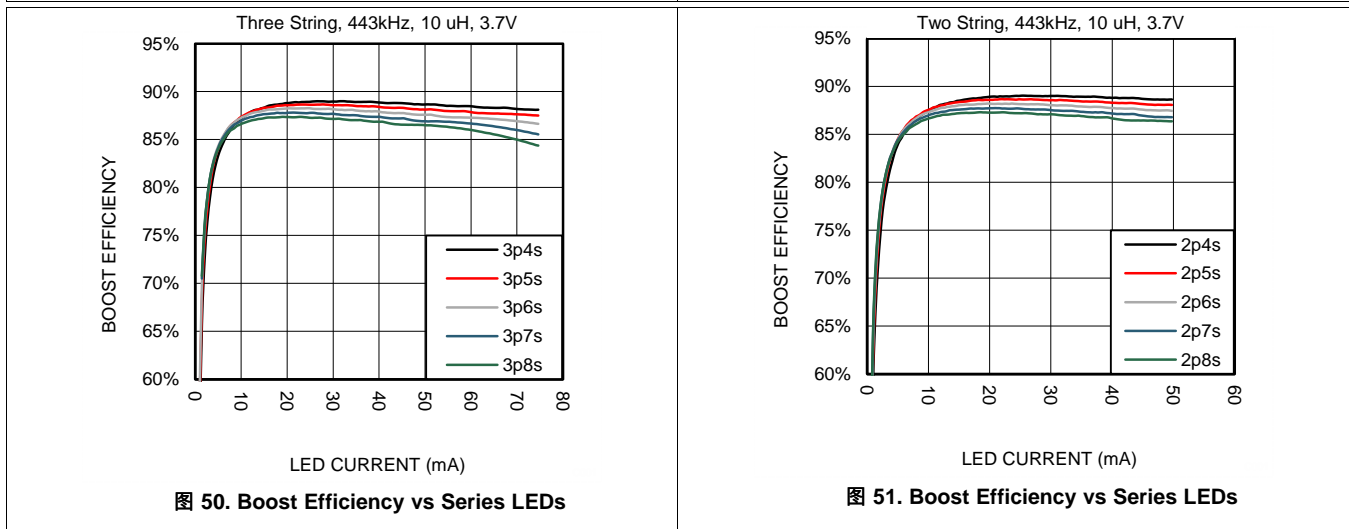
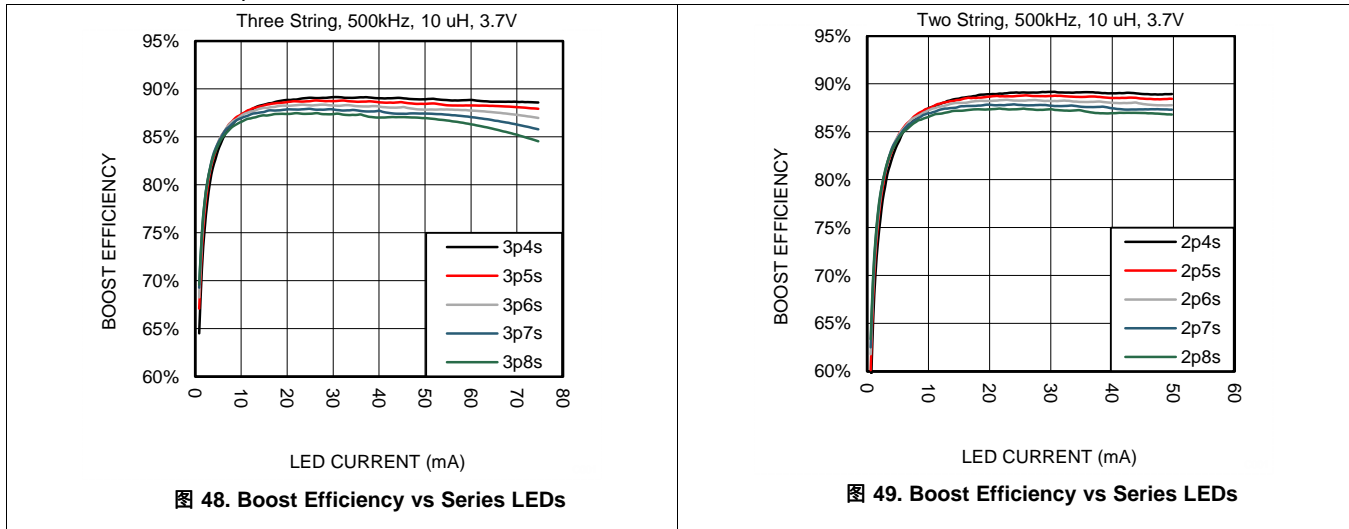

图 54. LED Matching (Exponential Mapping)



图 55. LED Matching (Linear Mapping)

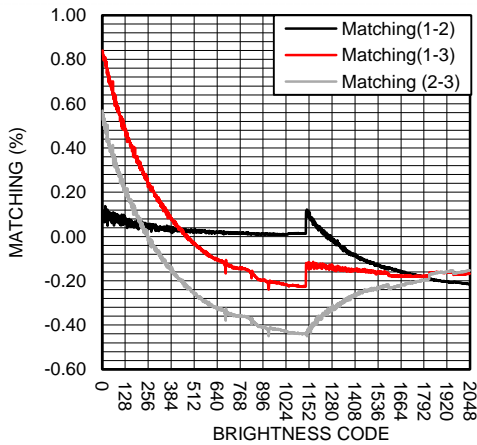

图 56. LED Current Accuracy

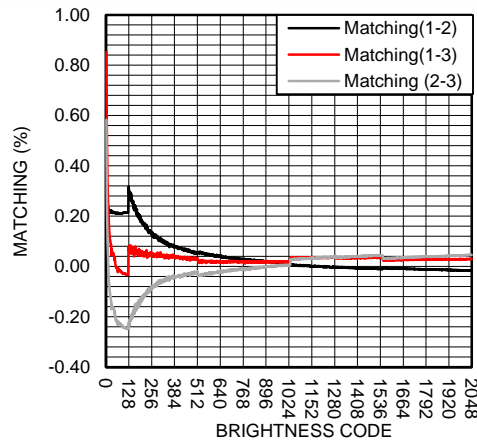

图 57. LED Current Accuracy

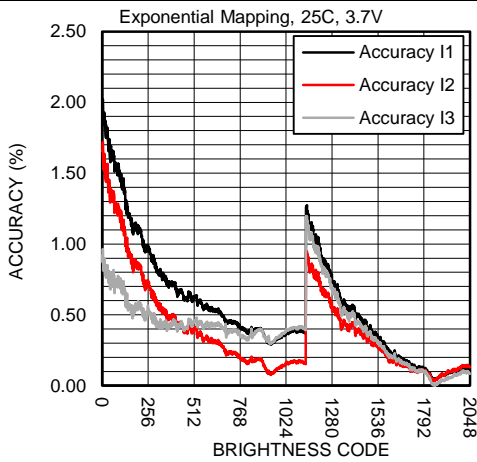

图 58. LED Headroom Voltage (Mis-Matched Strings)

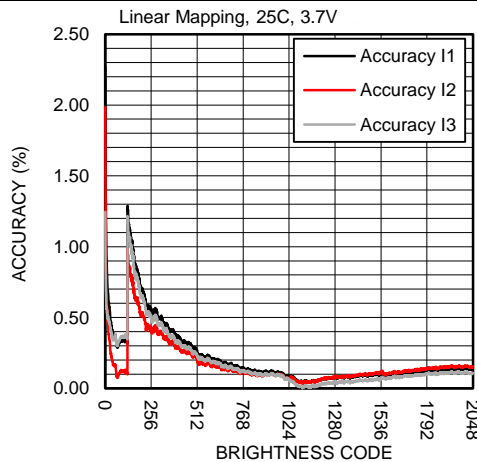

图 59. LED Headroom Voltage (Mis-Matched Strings)

LM36923

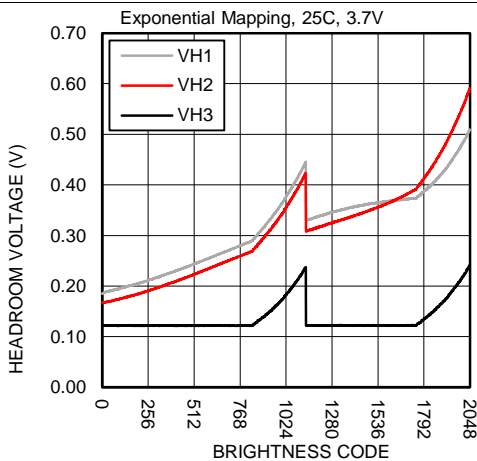
ZHCSDJ1 –MARCH 2015

www.ti.com.cn

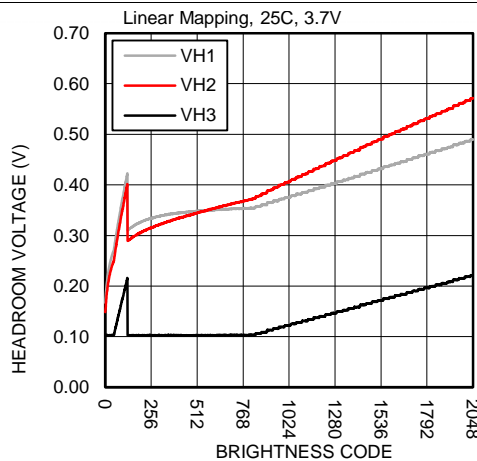
L1 = 10 μ H (VLF403212-100M) or 22 μ H (VLF504015-220M) as noted in graphs, D1 = NSR530P2T5G, LEDs are Rohm SML312WBCW1, temperature = 25°C, V_{IN} = 3.7 V, unless otherwise noted.



图 60. Current vs PWM Sample Frequency

9 Power Supply Recommendations

9.1 Input Supply Bypassing

The LM36923 is designed to operate from an input supply range of 2.5 V to 5.5 V. This input supply should be well regulated and be able to provide the peak current required by the LED configuration and inductor selected without voltage drop under load transients (start-up or rapid brightness change). The resistance of the input supply rail should be low enough such that the input current transient does not cause the LM36923 supply voltage to droop more than 5%. Additional bulk decoupling located close to the input capacitor (C_{IN}) may be required to minimize the impact of the input supply rail resistance.

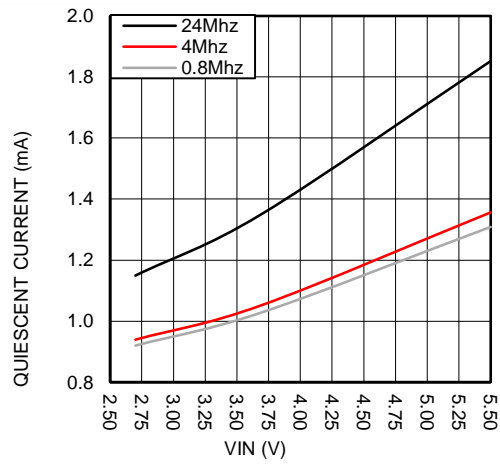
10 Layout

10.1 Layout Guidelines

The LM36923's inductive boost converter sees a high switched voltage (up to V_{OVP}) at the SW pin, and a step current (up to I_{CL}) through the Schottky diode and output capacitor each switching cycle. The high switching voltage can create interference into nearby nodes due to electric field coupling ($I = CdV/dt$). The large step current through the diode and the output capacitor can cause a large voltage spike at the SW pin and the OUT pin due to parasitic inductance in the step current conducting path ($V = Ldi/dt$). Board layout guidelines are geared towards minimizing this electric field coupling and conducted noise. Figure 61 highlights these two noise-generating components.



图 61. SW Pin Voltage (High dV/dt) and Current Through Schottky Diode and C_{OUT} (High dI/dt)

Layout Guidelines (接下页)

The following list details the main (layout sensitive) areas of the LM36923's inductive boost converter in order of decreasing importance:

- Output Capacitor
 - Schottky Cathode to COUT+
 - COUT– to GND
- Schottky Diode
 - SW pin to Schottky Anode
 - Schottky Cathode to COUT+
- Inductor
 - SW Node PCB capacitance to other traces
- Input Capacitor
 - CIN+ to IN pin

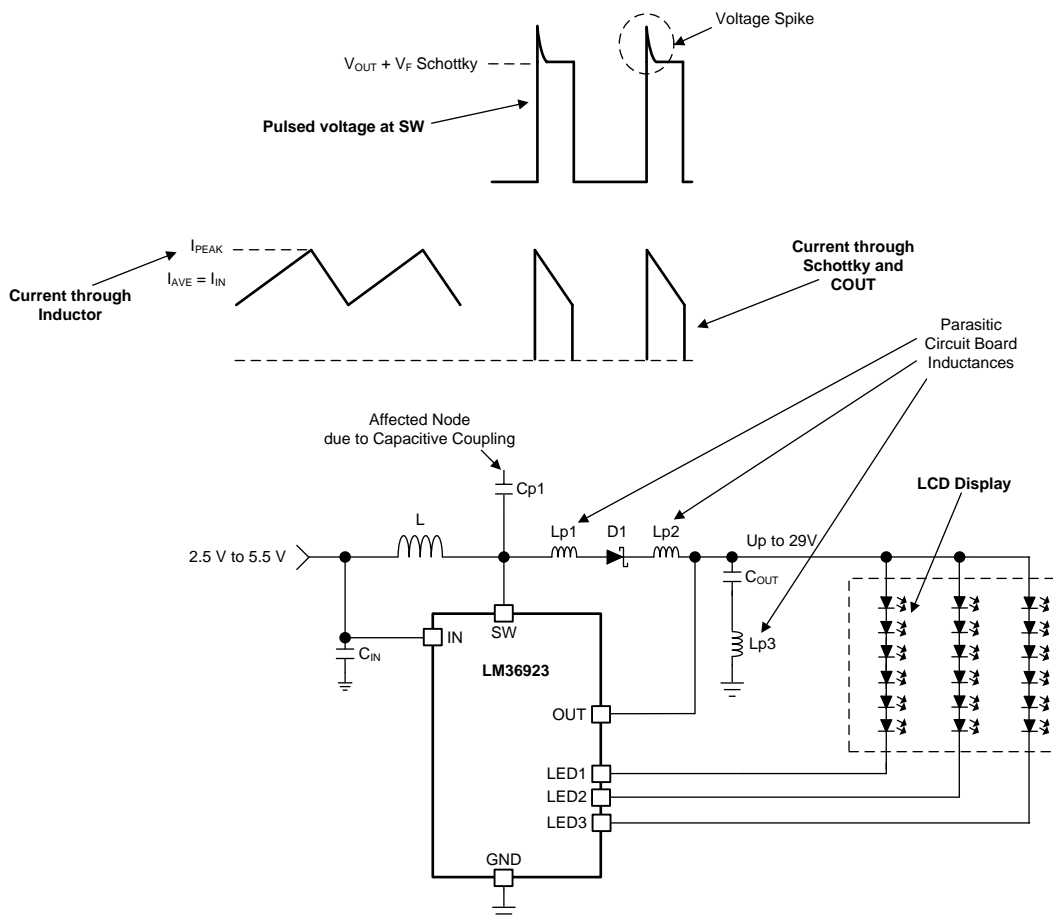
10.1.1 Boost Output Capacitor Placement

Because the output capacitor is in the path of the inductor current discharge path it detects a high-current step from 0 to I_{PEAK} each time the switch turns off and the Schottky diode turns on. Any inductance along this series path from the cathode of the diode through C_{OUT} and back into the LM36923's GND pin contributes to voltage spikes ($V_{SPIKE} = L_P \times di/dt$) at SW and OUT. These spikes can potentially overvoltage the SW pin, or feed through to GND. To avoid this, COUT+ must be connected as close as possible to the cathode of the Schottky diode, and COUT– must be connected as close as possible to the LM36923's GND pin. The best placement for COUT is on the same layer as the LM36923 in order to avoid any vias that can add excessive series inductance.

10.1.2 Schottky Diode Placement

In the LM36923's boost circuit the Schottky diode is in the path of the inductor current discharge. As a result the Schottky diode sees a high-current step from 0 to I_{PEAK} each time the switch turns off and the diode turns on. Any inductance in series with the diode causes a voltage spike ($V_{SPIKE} = L_P \times di/dt$) at SW and OUT. This can potentially over-voltage the SW pin, or feed through to V_{OUT} and through the output capacitor and into GND. Connecting the anode of the diode as close as possible to the SW pin and the cathode of the diode as close as possible to C_{OUT} and reduces the inductance (L_P) and minimize these voltage spikes.

10.1.3 Inductor Placement

The node where the inductor connects to the LM36923's SW pin has 2 issues. First, a large switched voltage (0 to $V_{OUT} + V_{F_SCHOTTKY}$) appears on this node every switching cycle. This switched voltage can be capacitively coupled into nearby nodes. Second, there is a relatively large current (input current) on the traces connecting the input supply to the inductor and connecting the inductor to the SW bump. Any resistance in this path can cause voltage drops that can negatively affect efficiency and reduce the input operating voltage range. To reduce the capacitive coupling of the signal on SW into nearby traces, the SW bump-to-inductor connection must be minimized in area. This limits the PCB capacitance from SW to other traces. Additionally, high impedance nodes that are more susceptible to electric field coupling need to be routed away from SW and not directly adjacent or beneath. This is especially true for traces such as SCL, SDA, HWEN, BL_ADJ, and PWM. A GND plane placed directly below SW dramatically reduces the capacitance from SW into nearby traces. Lastly, limit the trace resistance of the V_{IN} to inductor connection and from the inductor to SW connection, by use of short, wide traces.

10.1.4 Boost Input Capacitor Placement

For the LM36923 boost converter, the input capacitor filters the inductor current ripple and the internal MOSFET driver currents during turn on of the internal power switch. The driver current requirement can range from 50 mA at 2.7 V to over 200 mA at 5.5 V with fast durations of approximately 10 ns to 20 ns. This appears as high di/dt current pulses coming from the input capacitor each time the switch turns on. Close placement of the input capacitor to the IN pin and to the GND pin is critical since any series inductance between IN and CIN+ or CIN– and GND can create voltage spikes that could appear on the VIN supply line and in the GND plane. Close

Layout Guidelines (接下页)

placement of the input bypass capacitor at the input side of the inductor is also critical. The source impedance (inductance and resistance) from the input supply, along with the input capacitor of the LM36923, form a series RLC circuit. If the output resistance from the source (R_S) is low enough the circuit is underdamped and has a resonant frequency (typically the case). Depending on the size of L_S the resonant frequency could occur below, close to, or above the LM36923 switching frequency. This can cause the supply current ripple to be:

1. Approximately equal to the inductor current ripple when the resonant frequency occurs well above the LM36923 switching frequency;
2. Greater than the inductor current ripple when the resonant frequency occurs near the switching frequency; or
3. Less than the inductor current ripple when the resonant frequency occurs well below the switching frequency.

图 62 shows the series RLC circuit formed from the output impedance of the supply and the input capacitor. The circuit is redrawn for the AC case where the V_{IN} supply is replaced with a short to GND, and the LM36923 + Inductor is replaced with a current source (ΔI_L). Equation 1 is the criteria for an underdamped response. Equation 2 is the resonant frequency. Equation 3 is the approximated supply current ripple as a function of L_S , R_S , and C_{IN} . As an example, consider a 3.6-V supply with 0.1 Ω of series resistance connected to C_{IN} through 50 nH of connecting traces. This results in an underdamped input-filter circuit with a resonant frequency of 712 kHz. Since both the 1-MHz and 500-kHz switching frequency options lie close to the resonant frequency of the input filter, the supply current ripple is probably larger than the inductor current ripple. In this case, using equation 3, the supply current ripple can be approximated as 1.68 times the inductor current ripple (using a 500-kHz switching frequency) and 0.86 times the inductor current ripple using a 1-MHz switching frequency. Increasing the series inductance (L_S) to 500 nH causes the resonant frequency to move to around 225 kHz, and the supply current ripple to be approximately 0.25 times the inductor current ripple (500-kHz switching frequency) and 0.053 times for a 1-MHz switching frequency.



图 62. Input RLC Network

10.2 Layout Example

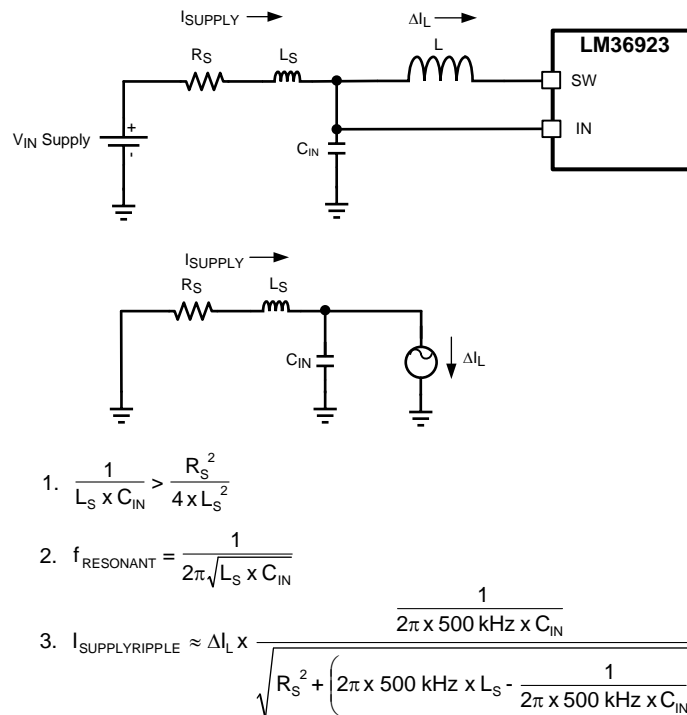

图 63. LM36923 Layout Example

11 器件和文档支持

11.1 器件支持

11.1.1 第三方产品免责声明

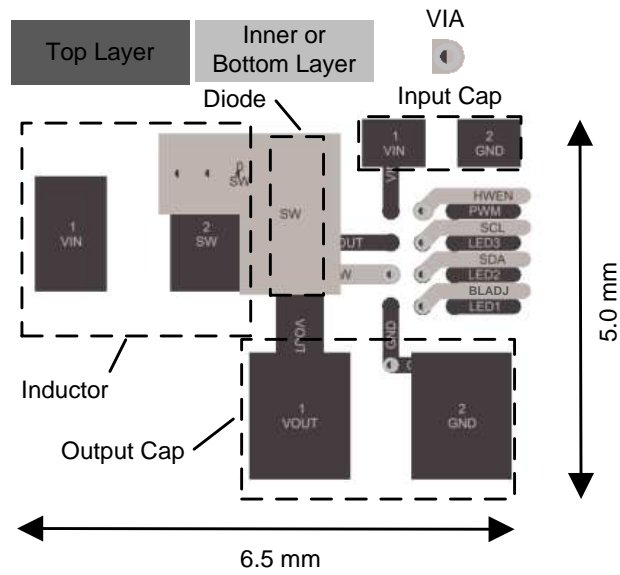
TI 发布的与第三方产品或服务有关的信息，不能构成与此类产品或服务或保修的适用性有关的认可，不能构成此类产品或服务单独或与任何 TI 产品或服务一起的表示或认可。

11.2 商标

All trademarks are the property of their respective owners.

11.3 静电放电警告



ESD 可能会损坏该集成电路。德州仪器 (TI) 建议通过适当的预防措施处理所有集成电路。如果不遵守正确的处理措施和安装程序，可能会损坏集成电路。

ESD 的损坏小至导致微小的性能降级，大至整个器件故障。精密的集成电路可能更容易受到损坏，这是因为非常细微的参数更改都可能会导致器件与其发布的规格不相符。

11.4 术语表

[SLYZ022](#) — TI 术语表。

这份术语表列出并解释术语、首字母缩略词和定义。

12 机械封装和可订购信息

以下页中包括机械封装和可订购信息。 这些信息是针对指定器件可提供的最新数据。 这些数据会在无通知且不对本文档进行修订的情况下发生改变。 欲获得该数据表的浏览器版本，请查阅左侧的导航栏。

重要声明

德州仪器(TI)及其下属子公司有权根据 JESD46 最新标准,对所提供的产品和服务进行更正、修改、增强、改进或其它更改,并有权根据 JESD48 最新标准中止提供任何产品和服务。客户在下订单前应获取最新的相关信息,并验证这些信息是否完整且是最新的。所有产品的销售都遵循在订单确认时所提供的TI 销售条款与条件。

TI 保证其所销售的组件的性能符合产品销售时 TI 半导体产品销售条件与条款的适用规范。仅在 TI 保证的范围内,且 TI 认为有必要时才会使用测试或其它质量控制技术。除非适用法律做出了硬性规定,否则没有必要对每种组件的所有参数进行测试。

TI 对应用帮助或客户产品设计不承担任何义务。客户应对其使用 TI 组件的产品和应用自行负责。为尽量减小与客户产品和应用相关的风险,客户应提供充分的设计与操作安全措施。

TI 不对任何 TI 专利权、版权、屏蔽作品权或其它与使用了 TI 组件或服务的组合设备、机器或流程相关的 TI 知识产权中授予的直接或隐含权限作出任何保证或解释。TI 所发布的与第三方产品或服务有关的信息,不能构成从 TI 获得使用这些产品或服务的许可、授权、或认可。使用此类信息可能需要获得第三方的专利权或其它知识产权方面的许可,或是 TI 的专利权或其它知识产权方面的许可。

对于 TI 的产品手册或数据表中 TI 信息的重要部分,仅在没有对内容进行任何篡改且带有相关授权、条件、限制和声明的情况下才允许进行复制。TI 对此类篡改过的文件不承担任何责任或义务。复制第三方的信息可能需要服从额外的限制条件。

在转售 TI 组件或服务时,如果对该组件或服务参数的陈述与 TI 标明的参数相比存在差异或虚假成分,则会失去相关 TI 组件或服务的所有明示或暗示授权,且这是不正当的、欺诈性商业行为。TI 对任何此类虚假陈述均不承担任何责任或义务。

客户认可并同意,尽管任何应用相关信息或支持仍可能由 TI 提供,但他们将独立负责满足与其产品及其在应用中使用的 TI 产品相关的所有法律、法规和安全相关要求。客户声明并同意,他们具备制定与实施安全措施所需的全部专业技术和知识,可预见故障的危险后果、监测故障及其后果、降低有可能造成人身伤害的故障的发生机率并采取适当的补救措施。客户将全额赔偿因在此类安全关键应用中使用任何 TI 组件而对 TI 及其代理造成的任何损失。

在某些场合中,为了推进安全相关应用有可能对 TI 组件进行特别的促销。TI 的目标是利用此类组件帮助客户设计和创立其特有的可满足适用的功能安全性标准和要求的终端产品解决方案。尽管如此,此类组件仍然服从这些条款。

TI 组件未获得用于 FDA Class III (或类似的生命攸关医疗设备)的授权许可,除非各方授权官员已经达成了专门管控此类使用的特别协议。

只有那些 TI 特别注明属于军用等级或“增强型塑料”的 TI 组件才是设计或专门用于军事/航空应用或环境的。购买者认可并同意,对并非指定面向军事或航空航天用途的 TI 组件进行军事或航空航天方面的应用,其风险由客户单独承担,并且由客户独立负责满足与此类使用相关的所有法律和法规要求。

TI 已明确指定符合 ISO/TS16949 要求的产品,这些产品主要用于汽车。在任何情况下,因使用非指定产品而无法达到 ISO/TS16949 要求, TI 不承担任何责任。

| | 产品 | | 应用 |
|---------------|--|--------------|--|
| 数字音频 | www.ti.com.cn/audio | 通信与电信 | www.ti.com.cn/telecom |
| 放大器和线性器件 | www.ti.com.cn/amplifiers | 计算机及周边 | www.ti.com.cn/computer |
| 数据转换器 | www.ti.com.cn/dataconverters | 消费电子 | www.ti.com.cn/consumer-apps |
| DLP® 产品 | www.dlp.com | 能源 | www.ti.com.cn/energy |
| DSP - 数字信号处理器 | www.ti.com.cn/dsp | 工业应用 | www.ti.com.cn/industrial |
| 时钟和计时器 | www.ti.com.cn/clockandtimers | 医疗电子 | www.ti.com.cn/medical |
| 接口 | www.ti.com.cn/interface | 安防应用 | www.ti.com.cn/security |
| 逻辑 | www.ti.com.cn/logic | 汽车电子 | www.ti.com.cn/automotive |
| 电源管理 | www.ti.com.cn/power | 视频和影像 | www.ti.com.cn/video |
| 微控制器 (MCU) | www.ti.com.cn/microcontrollers | | |
| RFID 系统 | www.ti.com.cn/rfidsys | | |
| OMAP应用处理器 | www.ti.com/omap | | |
| 无线连通性 | www.ti.com.cn/wirelessconnectivity | 德州仪器在线技术支持社区 | www.deyisupport.com |

邮寄地址: 上海市浦东新区世纪大道1568号, 中建大厦32楼邮政编码: 200122
Copyright © 2015, 德州仪器半导体技术(上海)有限公司

PACKAGING INFORMATION

| Orderable Device | Status (1) | Package Type | Package Drawing | Pins | Package Qty | Eco Plan (2) | Lead finish/ Ball material (6) | MSL Peak Temp (3) | Op Temp (°C) | Device Marking (4/5) | Samples |
|------------------|---------------|--------------|--------------------|------|----------------|-----------------|--------------------------------------|----------------------|--------------|-------------------------|----------------|
| LM36923YFFR | ACTIVE | DSBGA | YFF | 12 | 3000 | RoHS & Green | SNAGCU | Level-1-260C-UNLIM | -40 to 85 | 36923 | Samples |

(1) The marketing status values are defined as follows:

ACTIVE: Product device recommended for new designs.

LIFEBUY: TI has announced that the device will be discontinued, and a lifetime-buy period is in effect.

NRND: Not recommended for new designs. Device is in production to support existing customers, but TI does not recommend using this part in a new design.

PREVIEW: Device has been announced but is not in production. Samples may or may not be available.

OBSELETE: TI has discontinued the production of the device.

(2) **RoHS:** TI defines "RoHS" to mean semiconductor products that are compliant with the current EU RoHS requirements for all 10 RoHS substances, including the requirement that RoHS substance do not exceed 0.1% by weight in homogeneous materials. Where designed to be soldered at high temperatures, "RoHS" products are suitable for use in specified lead-free processes. TI may reference these types of products as "Pb-Free".

RoHS Exempt: TI defines "RoHS Exempt" to mean products that contain lead but are compliant with EU RoHS pursuant to a specific EU RoHS exemption.

Green: TI defines "Green" to mean the content of Chlorine (Cl) and Bromine (Br) based flame retardants meet JS709B low halogen requirements of <=1000ppm threshold. Antimony trioxide based flame retardants must also meet the <=1000ppm threshold requirement.

(3) MSL, Peak Temp. - The Moisture Sensitivity Level rating according to the JEDEC industry standard classifications, and peak solder temperature.

(4) There may be additional marking, which relates to the logo, the lot trace code information, or the environmental category on the device.

(5) Multiple Device Markings will be inside parentheses. Only one Device Marking contained in parentheses and separated by a "-" will appear on a device. If a line is indented then it is a continuation of the previous line and the two combined represent the entire Device Marking for that device.

(6) Lead finish/Ball material - Orderable Devices may have multiple material finish options. Finish options are separated by a vertical ruled line. Lead finish/Ball material values may wrap to two lines if the finish value exceeds the maximum column width.

Important Information and Disclaimer:The information provided on this page represents TI's knowledge and belief as of the date that it is provided. TI bases its knowledge and belief on information provided by third parties, and makes no representation or warranty as to the accuracy of such information. Efforts are underway to better integrate information from third parties. TI has taken and continues to take reasonable steps to provide representative and accurate information but may not have conducted destructive testing or chemical analysis on incoming materials and chemicals. TI and TI suppliers consider certain information to be proprietary, and thus CAS numbers and other limited information may not be available for release.

In no event shall TI's liability arising out of such information exceed the total purchase price of the TI part(s) at issue in this document sold by TI to Customer on an annual basis.

EXAMPLE BOARD LAYOUT

YFF0012

DSBGA - 0.625 mm max height

DIE SIZE BALL GRID ARRAY

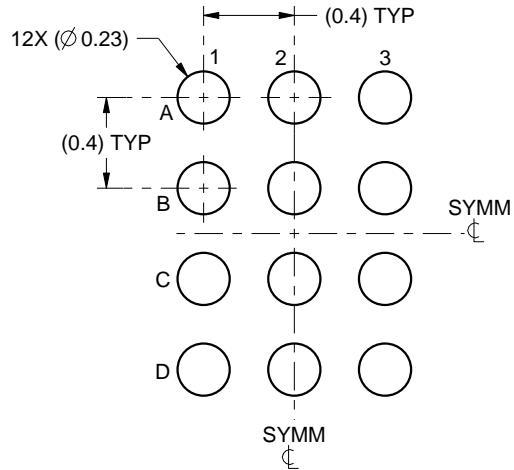

LAND PATTERN EXAMPLE
SCALE:30X

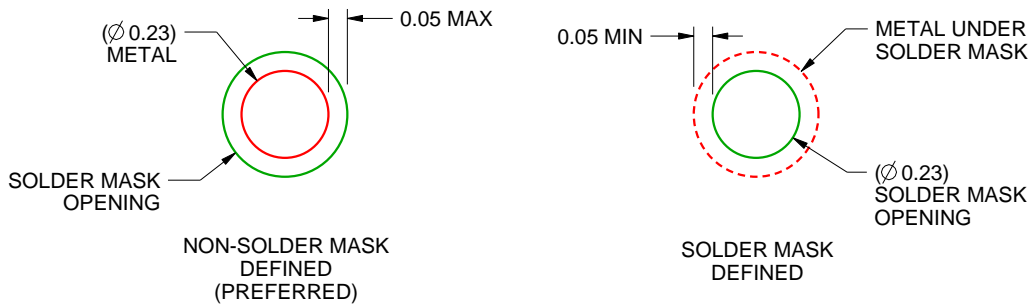

SOLDER MASK DETAILS
NOT TO SCALE

4222191/A 07/2015

NOTES: (continued)

3. Final dimensions may vary due to manufacturing tolerance considerations and also routing constraints. For more information, see Texas Instruments literature number SNVA009 (www.ti.com/lit/snva009).

EXAMPLE STENCIL DESIGN

YFF0012

DSBGA - 0.625 mm max height

DIE SIZE BALL GRID ARRAY

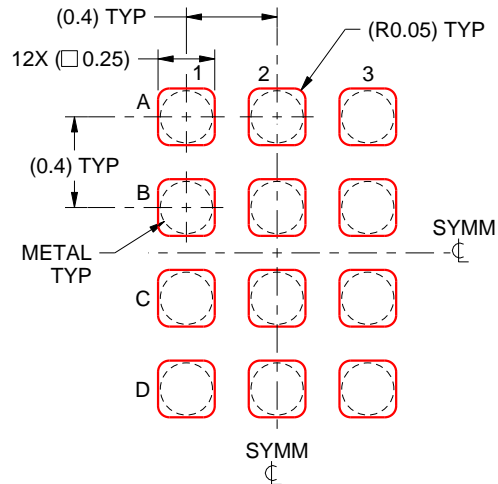

SOLDER PASTE EXAMPLE
BASED ON 0.1 mm THICK STENCIL
SCALE:30X

4222191/A 07/2015

NOTES: (continued)

4. Laser cutting apertures with trapezoidal walls and rounded corners may offer better paste release.

重要声明和免责声明

TI 均以“原样”提供技术性 & 可靠性数据（包括数据表）、设计资源（包括参考设计）、应用或其他设计建议、网络工具、安全信息和其他资源，不保证其中不含任何瑕疵，且不做任何明示或暗示的担保，包括但不限于对适销性、适合某特定用途或不侵犯任何第三方知识产权的暗示担保。

所述资源可供专业开发人员应用 TI 产品进行设计使用。您将对以下行为独自承担全部责任：(1) 针对您的应用选择合适的 TI 产品；(2) 设计、验证并测试您的应用；(3) 确保您的应用满足相应标准以及任何其他安全、安保或其他要求。所述资源如有变更，恕不另行通知。TI 对您使用所述资源的授权仅限于开发资源所涉及 TI 产品的相关应用。除此之外不得复制或展示所述资源，也不提供其它 TI 或任何第三方的知识产权授权许可。如因使用所述资源而产生任何索赔、赔偿、成本、损失及债务等，TI 对此概不负责，并且您须赔偿由此对 TI 及其代表造成的损害。

TI 所提供产品均受 TI 的销售条款 (<http://www.ti.com.cn/zh-cn/legal/termsofsale.html>) 以及 [ti.com.cn](http://www.ti.com.cn) 上或随附 TI 产品提供的其他可适用条款的约束。TI 提供所述资源并不扩展或以其他方式更改 TI 针对 TI 产品所发布的可适用的担保范围或担保免责声明。

邮寄地址：上海市浦东新区世纪大道 1568 号中建大厦 32 楼，邮政编码：200122

Copyright © 2020 德州仪器半导体技术（上海）有限公司