

## FEATURES

- **Auto-Power-Up Feature Prevents Printer Errors When Printer Is Turned On, But No Valid Signal Is at A9–A13 Pins**
- **1.4-k $\Omega$  Pullup Resistors Integrated on All Open-Drain Outputs Eliminate the Need for Discrete Resistors**
- **Designed for IEEE Std 1284-I (Level-1 Type) and IEEE Std 1284-II (Level-2 Type) Electrical Specifications**
- **Flow-Through Architecture Optimizes PCB Layout**
- **I<sub>off</sub> and Power-Up 3-State Support Hot Insertion**
- **Latch-Up Performance Exceeds 100 mA Per JESD 78, Class II**
- **ESD Protection**
  - $\pm 4$  kV – Human-Body Model
  - $\pm 8$  kV – IEC 61000-4-2, Contact Discharge (Connector Pins)
  - $\pm 15$  kV – IEC 61000-4-2, Air-Gap Discharge (Connector Pins)
  - $\pm 15$  kV – Human-Body Model (Connector Pins)

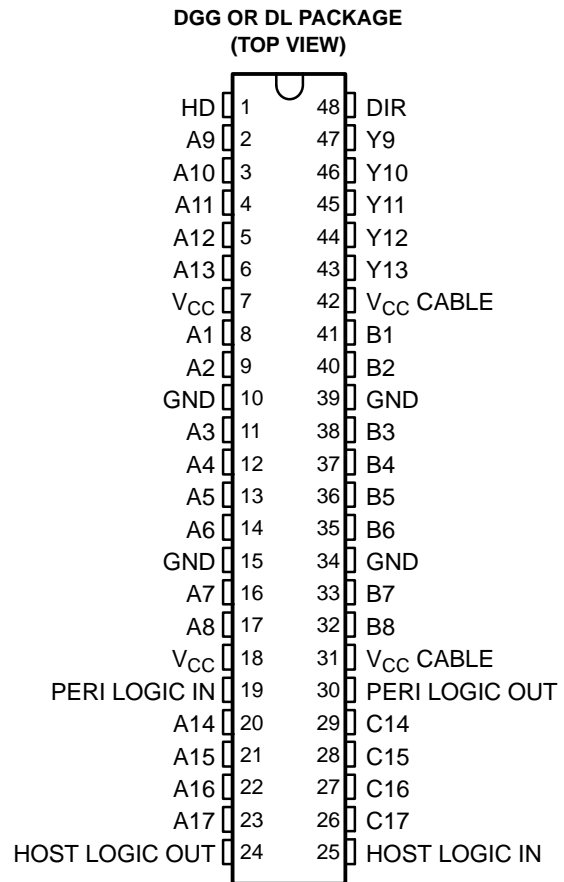

## DESCRIPTION/ORDERING INFORMATION

The SN74LVCE161284 is designed for 3-V to 3.6-V  $V_{CC}$  operation. This device provides asynchronous two-way communication between data buses. The control-function implementation minimizes external timing requirements.

This device has eight bidirectional bits; data can flow in the A-to-B direction when the direction-control input (DIR) is high and in the B-to-A direction when DIR is low. This device also has five drivers that drive the cable side and four receivers. The SN74LVCE161284 has one receiver dedicated to the HOST LOGIC line and a driver to drive the PERI LOGIC line.

## ORDERING INFORMATION

T <sub>A</sub>	PACKAGE <sup>(1)</sup>		ORDERABLE PART NUMBER	TOP-SIDE MARKING
0°C to 70°C	SSOP – DL	Tube	SN74LVCE161284DL	LVCE161284
		Tape and reel	SN74LVCE161284DLR	
	TSSOP – DGG	Tape and reel	SN74LVCE161284DGGR	LVCE161284

(1) Package drawings, standard packing quantities, thermal data, symbolization, and PCB design guidelines are available at [www.ti.com/sc/package](http://www.ti.com/sc/package).



Please be aware that an important notice concerning availability, standard warranty, and use in critical applications of Texas Instruments semiconductor products and disclaimers thereto appears at the end of this data sheet.

**SN74LVCE161284**  
**19-BIT IEEE STD 1284 TRANSLATION TRANSCEIVER**  
**WITH ERROR-FREE POWER UP**



SCES541 – JANUARY 2004 – REVISED MARCH 2005

**DESCRIPTION/ORDERING INFORMATION (CONTINUED)**

The output drive mode is determined by the high-drive (HD) control pin. When HD is high, the outputs are in a totem-pole configuration, and in an open-drain configuration when HD is low. This meets the drive requirements as specified in the IEEE Std 1284-I (level-1 type) and IEEE Std 1284-II (level-2 type) parallel peripheral-interface specifications. Except for HOST LOGIC IN and peripheral logic out (PERI LOGIC OUT), all cable-side pins have a 1.4-kΩ integrated pullup resistor. The pullup resistor is switched off if the associated output driver is in the low state or if the output voltage is above  $V_{CC}$  CABLE. If  $V_{CC}$  CABLE is off, PERI LOGIC OUT is set to low.

The device has two supply voltages.  $V_{CC}$  is designed for 3-V to 3.6-V operation.  $V_{CC}$  CABLE supplies the inputs and output buffers of the cable side only and is designed for 3-V to 3.6-V and for 4.7-V to 5.5-V operation. Even when  $V_{CC}$  CABLE is 3 V to 3.6 V, the cable-side I/O pins are 5-V tolerant.

The Y outputs (Y9–Y13) stay in the high state after power on until an associated input (A9–A13) goes high. When an associated input goes high, all Y outputs are activated, and noninverting signals of the associated inputs are driven through Y outputs. This special feature prevents printer-system errors caused by deasserting the BUSY signal in the cable at power on.

**FUNCTION TABLE**

INPUTS		OUTPUT	MODE
DIR	HD		
L	L	Open drain	A9–A13 to Y9–Y13 and PERI LOGIC IN to PERI LOGIC OUT
		Totem pole	B1–B8 to A1–A8 and C14–C17 to A14–A17
L	H	Totem pole	B1–B8 to A1–A8, A9–A13 to Y9–Y13, PERI LOGIC IN to PERI LOGIC OUT, and C14–C17 to A14–A17
H	L	Open drain	A1–A8 to B1–B8, A9–A13 to Y9–Y13, and PERI LOGIC IN to PERI LOGIC OUT
		Totem pole	C14–C17 to A14–A17
H	H	Totem pole	A1–A8 to B1–B8, A9–A13 to Y9–Y13, C14–C17 to A14–A17, and PERI LOGIC IN to PERI LOGIC OUT

**LOGIC DIAGRAM**

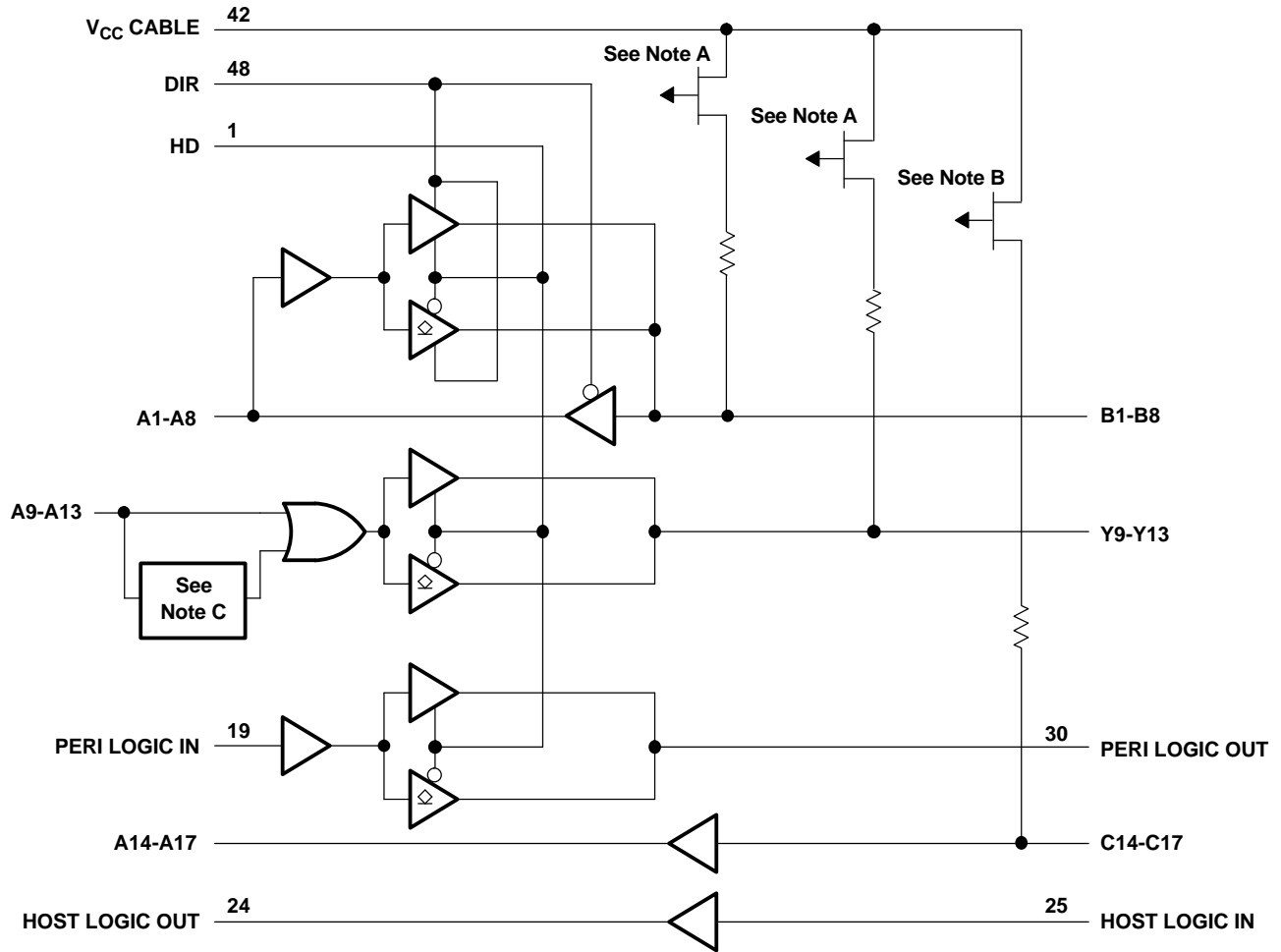

- NOTES: A. The PMOS transistors prevent backdriving current from the signal pins to V<sub>CC</sub> CABLE when V<sub>CC</sub> CABLE is open or at GND. The PMOS transistor is turned off when the associated driver is in the low state.
- B. The PMOS transistor prevents backdriving current from the signal pins to V<sub>CC</sub> CABLE when V<sub>CC</sub> CABLE is open or at GND.
- C. Active input detection circuit forces Y9-Y13 to the high state after power-on, until one of the A9-A13 goes high (see Figure 1).

**SN74LVCE161284**  
**19-BIT IEEE STD 1284 TRANSLATION TRANSCEIVER**  
**WITH ERROR-FREE POWER UP**

SCES541 – JANUARY 2004 – REVISED MARCH 2005

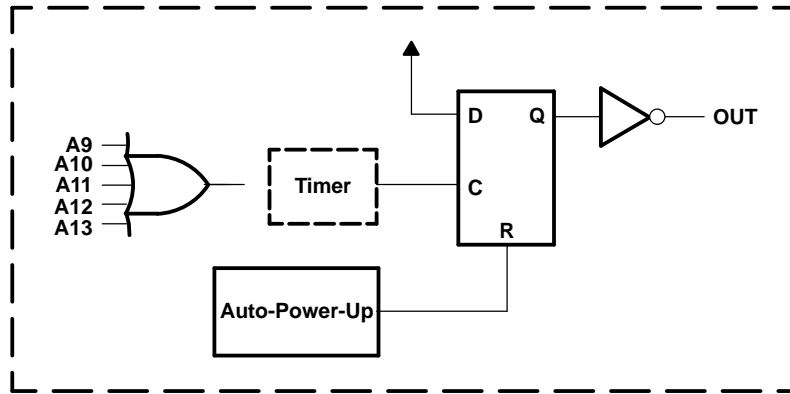

**Active Input Detection Circuit**

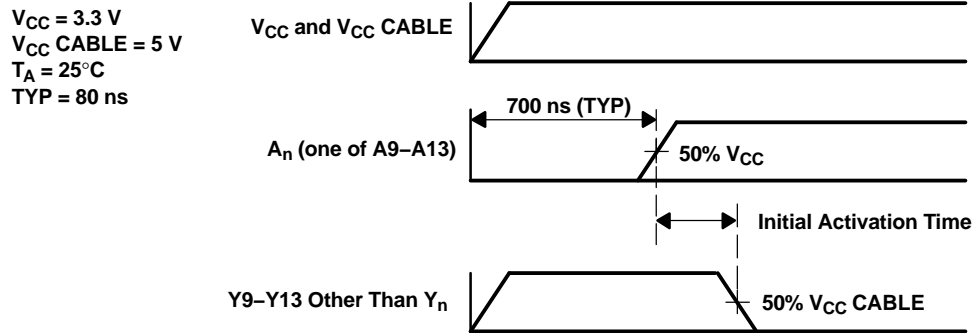

NOTE A: One of A9–A13 is switched as shown above, and the other four inputs are forced to low state.

**Figure 1. Error-Free Circuit Timing**

### Absolute Maximum Ratings<sup>(1)</sup>

over operating free-air temperature range (unless otherwise noted)

		MIN	MAX	UNIT	
V <sub>CC CABLE</sub>	Supply voltage range	−0.5	7	V	
V <sub>CC</sub>	Supply voltage range	−0.5	4.6	V	
V <sub>I</sub> , V <sub>O</sub>	Input and output voltage range	Cable side <sup>(2)(3)</sup>	−2	7	V
		Peripheral side <sup>(2)</sup>	−0.5	V <sub>CC</sub> + 0.5	V
I <sub>IK</sub>	Input clamp current	V <sub>I</sub> < 0	−20	mA	
I <sub>OK</sub>	Output clamp current	V <sub>O</sub> < 0	−50	mA	
I <sub>O</sub>	Continuous output current	Except PERI LOGIC OUT	±50	mA	
		PERI LOGIC OUT	±100	mA	
Continuous current through each V <sub>CC</sub> or GND			±200	mA	
I <sub>SK</sub>	Output high sink current	V <sub>O</sub> = 5.5 V and V <sub>CC CABLE</sub> = 3 V	65	mA	
θ <sub>JA</sub>	Package thermal impedance <sup>(4)</sup>	DGG package	70	°C/W	
		DL package	63		
T <sub>stg</sub>	Storage temperature range	−65	150	°C	

- (1) Stresses beyond those listed under "absolute maximum ratings" may cause permanent damage to the device. These are stress ratings only, and functional operation of the device at these or any other conditions beyond those indicated under "recommended operating conditions" is not implied. Exposure to absolute-maximum-rated conditions for extended periods may affect device reliability.
- (2) The input and output voltage ratings may be exceeded if the input and output current ratings are observed.
- (3) The ac input-voltage pulse duration is limited to 40 ns if the amplitude is greater than −0.5 V.
- (4) The package thermal impedance is calculated in accordance with JESD 51-7.

### Recommended Operating Conditions<sup>(1)</sup>

		MIN	MAX	UNIT	
V <sub>CC CABLE</sub>	Supply voltage for the cable side, V <sub>CC CABLE</sub> ≥ V <sub>CC</sub>	3	5.5	V	
V <sub>CC</sub>	Supply voltage	3	3.6	V	
V <sub>IH</sub>	High-level input voltage	A, B, DIR, and HD	2	V	
		C14–C17	2.3		
		HOST LOGIC IN	2.6		
		PERI LOGIC IN	2		
V <sub>IL</sub>	Low-level input voltage	A, B, DIR, and HD	0.8	V	
		C14–C17	0.8		
		HOST LOGIC IN	1.6		
		PERI LOGIC IN	0.8		
V <sub>I</sub>	Input voltage	Peripheral side	0	V <sub>CC</sub>	V
		Cable side	0	5.5	
V <sub>O</sub>	Open-drain output voltage	HD low	0	5.5	V
I <sub>OH</sub>	High-level output current	HD high, B and Y outputs	−14	mA	
		A outputs and HOST LOGIC OUT	−4		
		PERI LOGIC OUT	−0.5		
I <sub>OL</sub>	Low-level output current	B and Y outputs	14	mA	
		A outputs and HOST LOGIC OUT	4		
		PERI LOGIC OUT	84		
T <sub>A</sub>	Operating free-air temperature	0	70	°C	

- (1) All unused inputs of the device must be held at V<sub>CC</sub> or GND to ensure proper device operation. Refer to the TI application report, *Implications of Slow or Floating CMOS Inputs*, literature number SCBA004.

**SN74LVCE161284**  
**19-BIT IEEE STD 1284 TRANSLATION TRANSCEIVER**  
**WITH ERROR-FREE POWER UP**

SCES541–JANUARY 2004–REVISED MARCH 2005

**Electrical Characteristics**

over recommended operating free-air temperature range (unless otherwise noted)

PARAMETER		TEST CONDITIONS	V <sub>CC</sub>	V <sub>CC</sub> CABLE	MIN	TYP <sup>(1)</sup>	MAX	UNIT
ΔV <sub>t</sub> Hysteresis (V <sub>T+</sub> – V <sub>T-</sub> )	All inputs except the C inputs and HOST LOGIC IN		3.3 V	5 V	0.4		V	
	HOST LOGIC IN	0.2						
	C inputs	0.8						
V <sub>OH</sub>	HD high, B and Y outputs	I <sub>OH</sub> = –14 mA	3 V	3 V	2.23		V	
			3.3 V	4.7 V	2.4			
	HD high, A outputs, and HOST LOGIC OUT	I <sub>OH</sub> = –4 mA	3 V	3 V	2.4			
		I <sub>OH</sub> = –50 μA			2.8			
	PERI LOGIC OUT	I <sub>OH</sub> = –0.5 mA	3.15 V	3.15 V	3.1			
			3.3 V	4.7 V	4.5			
V <sub>OL</sub>	B and Y outputs	I <sub>OL</sub> = 14 mA	3 V	3 V	0.77		V	
	A outputs and HOST LOGIC OUT	I <sub>OL</sub> = 50 μA			0.2			
		I <sub>OL</sub> = 4 mA			0.4			
	PERI LOGIC OUT	I <sub>OL</sub> = 84 mA			0.9			
I <sub>I</sub>	C inputs	V <sub>I</sub> = V <sub>CC</sub>	3.6 V	3.6 V	50		μA	
		V <sub>I</sub> = GND (pullup resistors)			–3.5		mA	
	All inputs except B or C inputs	V <sub>I</sub> = V <sub>CC</sub> or GND			5.5 V	±1		μA
I <sub>OZ</sub>	A1–A8	V <sub>O</sub> = V <sub>CC</sub> or GND	3.6 V	5.5 V	±20		μA	
		V <sub>O</sub> = V <sub>CC</sub> CABLE			50			
	B outputs	V <sub>O</sub> = GND (pullup resistors)		3.6 V	–3.5		mA	
		Open-drain Y outputs			V <sub>O</sub> = GND (pullup resistors)	–3.5		
I <sub>OZPU</sub>	B and Y outputs	V <sub>O</sub> = 5.5 V	0 to 1.5 V <sup>(2)</sup>	0 to 1.5 V <sup>(2)</sup>	350		μA	
		V <sub>O</sub> = GND			–5		mA	
I <sub>OZPD</sub>	B and Y outputs	V <sub>O</sub> = 5.5 V	0 to 1.5 V <sup>(2)</sup>	0 to 1.5 V <sup>(2)</sup>	350		μA	
		V <sub>O</sub> = GND			–5		mA	
I <sub>off</sub>	Power-down input leakage, except A1–A8 or B1–B8 inputs	V <sub>I</sub> or V <sub>O</sub> = 0 to 3.6 V	0	0	100		μA	
	Power-down output leakage, B1–B8 and Y9–Y13 outputs	V <sub>I</sub> or V <sub>O</sub> = 0 to 5.5 V			100			
I <sub>CC</sub>		V <sub>I</sub> = GND (12 × pullup)	3.6 V	3.6 V	45		mA	
				5.5 V	70			
		V <sub>I</sub> = V <sub>CC</sub> , I <sub>O</sub> = 0		3.6 V	0.8			
Z <sub>O</sub>	B1–B8, Y9–Y13	I <sub>OH</sub> = –35 mA	3.3 V	3.3 V	36		Ω	
R pullup	B1–B8, Y9–Y13, C14–C17	V <sub>O</sub> = 0 V (in high-impedance state)	3.3 V	3.3 V	1.15	1.65	kΩ	
C <sub>i</sub>	A9–A13, DIR, HD, PERI LOGIC IN	V <sub>I</sub> = V <sub>CC</sub> or GND	3.3 V	5 V	6.5		pF	
	HOST LOGIC IN				4			
C <sub>io</sub>	A1–A8	V <sub>O</sub> = V <sub>CC</sub> or GND	3.3 V	5 V	8		pF	
	B1–B8				13			

(1) Typical values are measured at T<sub>A</sub> = 25°C.

(2) Connect the V<sub>CC</sub> pin to the V<sub>CC</sub> CABLE pin.

### Switching Characteristics

over recommended ranges of supply voltage and operating free-air temperature (unless otherwise noted) (see Figure 2 and Figure 3)

PARAMETER		FROM (INPUT)	TO (OUTPUT)	MIN	TYP <sup>(1)</sup>	MAX	UNIT
t <sub>PLH</sub>	Totem pole	A1–A8	B1–B8	2		30	ns
t <sub>PHL</sub>				2		30	
t <sub>PLH</sub>	Totem pole	A9–A13	Y9–Y13	2		30	ns
t <sub>PHL</sub>				2		30	
t <sub>PLH</sub>	Totem pole	B1–B8	A1–A8	2		12	ns
t <sub>PHL</sub>				2		12	
t <sub>PLH</sub>	Totem pole	C14–C17	A14–A17	2		14	ns
t <sub>PHL</sub>				2		14	
t <sub>PLH</sub>	Totem pole	PERI LOGIC IN	PERI LOGIC OUT	2		16	ns
t <sub>PHL</sub>				2		16	
t <sub>PLH</sub>	Totem pole	HOST LOGIC IN	HOST LOGIC OUT	1		18	ns
t <sub>PHL</sub>				1		18	
t <sub>slew</sub>	Totem pole	B1–B8 and Y9–Y13 outputs		0.05		0.4	V/ns
t <sub>PZH</sub>		HD	B1–B8, Y9–Y13, and PERI LOGIC OUT	2		30	ns
t <sub>PHZ</sub>				2		25	
t <sub>en</sub> –t <sub>dis</sub>		DIR	A1–A8	2		25	ns
t <sub>PHZ</sub>		DIR	B1–B8	2		25	ns
t <sub>PLZ</sub>				2		25	
t <sub>r</sub> , t <sub>f</sub>	Open drain	A1–A13	B1–B8 or Y9–Y13	1		120	ns
t <sub>sk(o)</sub> <sup>(2)</sup>		A1–A8 or B1–B8	B1–B8 or A1–A8		3	10	ns

(1) Typical values are measured at V<sub>CC</sub> = 3.3 V, V<sub>CC CABLE</sub> = 5 V, and T<sub>A</sub> = 25°C.

(2) Skew is measured at 1/2 (V<sub>OH</sub> + V<sub>OL</sub>) for signals switching in the same direction.

**Table 1. ESD Protection**

PIN	TEST CONDITIONS	TYP	UNIT
B1–B8, Y9–Y13, PERI LOGIC OUT, C14–C17, HOST LOGIC IN	HBM	±15	kV
	Contact discharge, IEC 61000-4-2	±8	
	Air-gap discharge, IEC 61000-4-2	±15	
DIR, HD, A1–A8, A9–A13, PERI LOGIC IN, A14–A17, HOST LOGIC OUT	HBM	±4	kV

### Operating Characteristics

V<sub>CC</sub> and V<sub>CC CABLE</sub> = 3.3 V, C<sub>L</sub> = 0, f = 10 MHz, T<sub>A</sub> = 25°C

PARAMETER		FROM (INPUT)	TO (OUTPUT)	TYP	UNIT
C <sub>pd</sub>	Power dissipation capacitance	A	B	15	pF
		A	Y	6	
		PERI LOGIC IN	PERI LOGIC OUT	10	
		B	A	33	
		C	A	29	
		HOST LOGIC IN	HOST LOGIC OUT	29	

PARAMETER MEASUREMENT INFORMATION

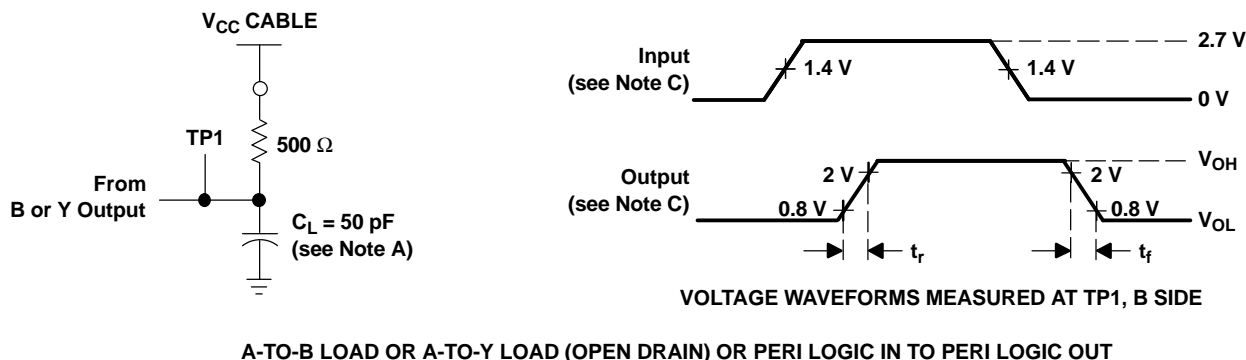
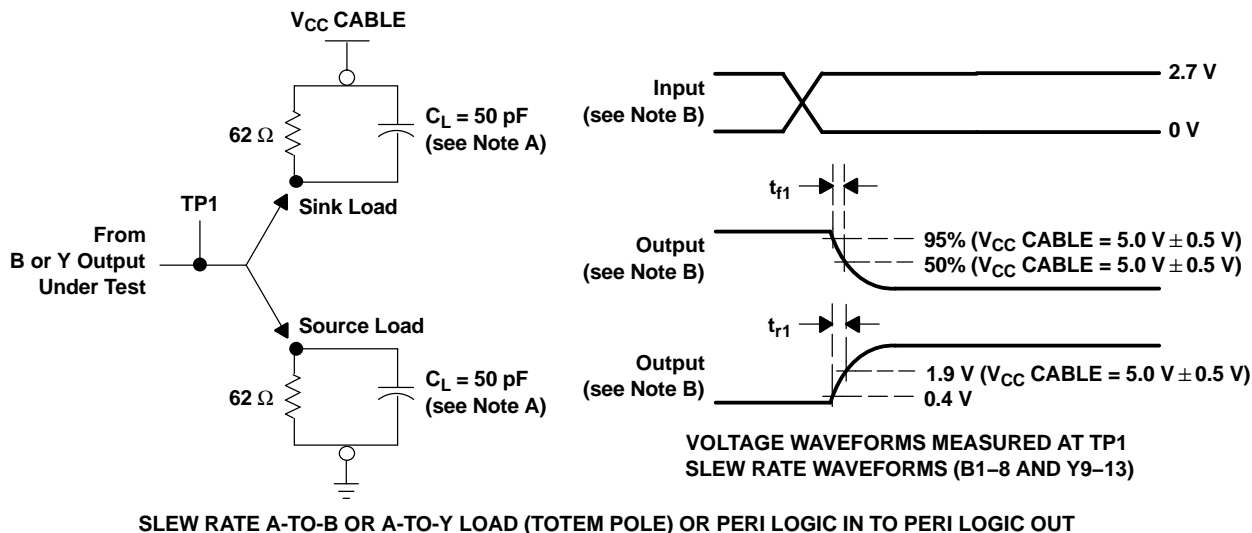

- NOTES: A. C<sub>L</sub> includes probe and jig capacitance.  
 B. When V<sub>CC</sub> CABLE is 3.3 V ± 0.3 V, slew rate is measured between 0.4 V and 0.9 V for the rising edge and between 2.4 V and 1.9 V for the falling edge. When V<sub>CC</sub> CABLE is 5 V ± 0.5 V, slew rate is measured between 0.4 V and 1.9 V for the rising edge and between 95% V<sub>CC</sub> CABLE and 50% V<sub>CC</sub> CABLE for the falling edge.

$$t_{\text{slew fall}} = V_{\text{CC}} \left( \frac{95\% - 50\%}{t_{f1}} \right) \quad t_{\text{slew rise}} = \left( \frac{1.9 \text{ V} - 0.4 \text{ V}}{t_{r1}} \right)$$

- C. Input rise (t<sub>r</sub>) and fall (t<sub>f</sub>) times are 3 ns. Rise and fall times (open drain) are <120 ns.  
 D. The outputs are measured one at a time, with one transition per measurement.  
 E. t<sub>PLZ</sub> and t<sub>PHZ</sub> are the same as t<sub>dis</sub>.  
 F. t<sub>PZL</sub> and t<sub>PZH</sub> are the same as t<sub>en</sub>.  
 G. t<sub>PLH</sub> and t<sub>PHL</sub> are the same as t<sub>pd</sub>.

Figure 2. Load Circuits and Voltage Waveforms

PARAMETER MEASUREMENT INFORMATION

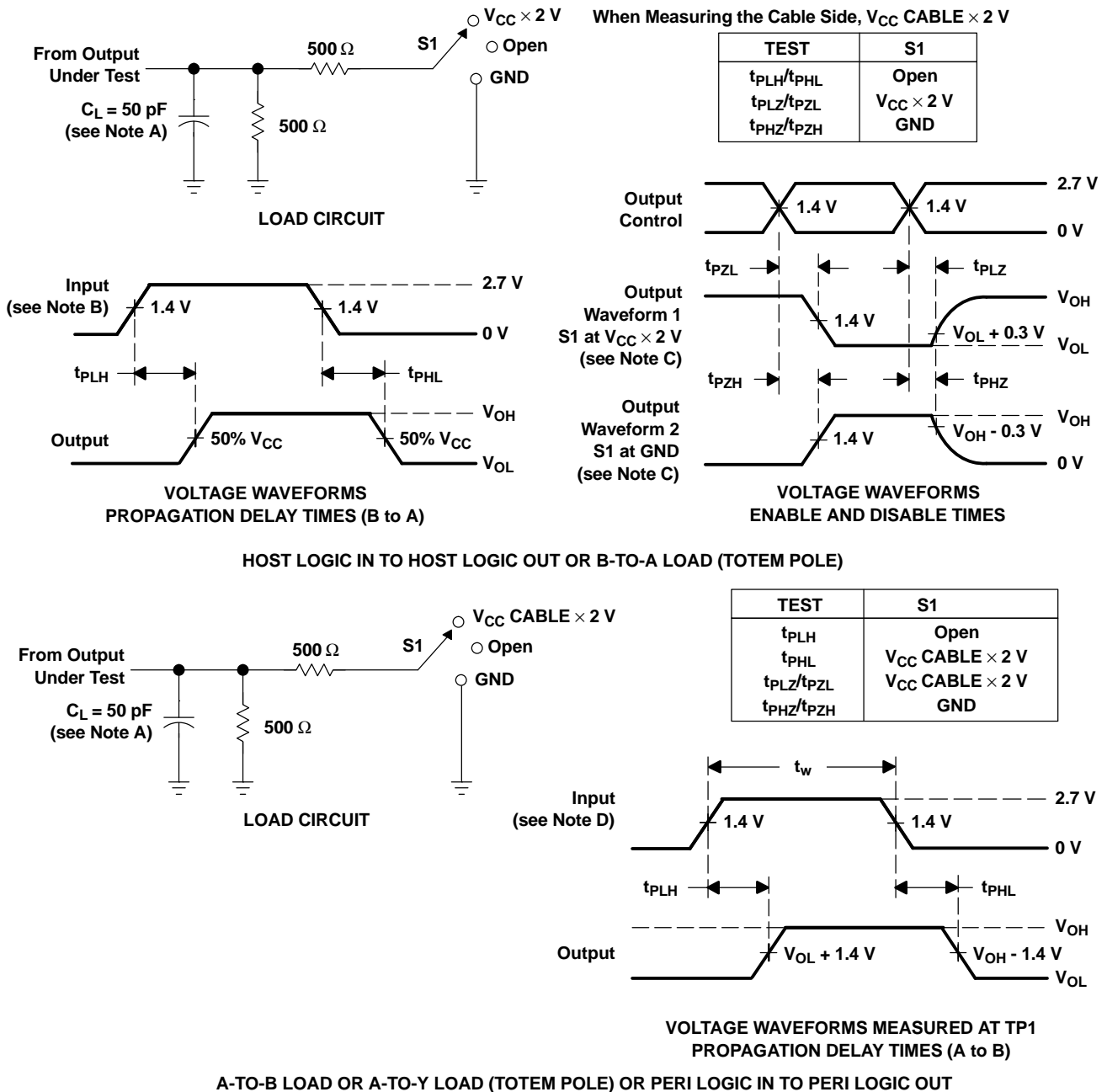

- NOTES:
- A.  $C_L$  includes probe and jig capacitance.
  - B. Input rise and fall times are 3 ns.
  - C. Waveform 1 is for an output with internal conditions such that the output is low, except when disabled by the output control. Waveform 2 is for an output with internal conditions such that the output is high, except when disabled by the output control.
  - D. Input rise and fall times are 3 ns. Pulse duration is  $150 \text{ ns} < t_w < 10 \mu\text{s}$ .
  - E. The outputs are measured one at a time, with one transition per measurement.
  - F.  $t_{PLZ}$  and  $t_{PHZ}$  are the same as  $t_{dis}$ .
  - G.  $t_{PZL}$  and  $t_{PZH}$  are the same as  $t_{en}$ .
  - H.  $t_{PLH}$  and  $t_{PHL}$  are the same as  $t_{pd}$ .

Figure 3. Load Circuits and Voltage Waveforms

## PACKAGING INFORMATION

Orderable Device	Status (1)	Package Type	Package Drawing	Pins	Package Qty	Eco Plan (2)	Lead finish/ Ball material (6)	MSL Peak Temp (3)	Op Temp (°C)	Device Marking (4/5)	Samples
74LVCE161284DLRG4	ACTIVE	SSOP	DL	48	1000	RoHS & Green	NIPDAU	Level-1-260C-UNLIM	0 to 70	LVCE161284	<a href="#">Samples</a>
SN74LVCE161284DGGR	ACTIVE	TSSOP	DGG	48	2000	RoHS & Green	NIPDAU	Level-1-260C-UNLIM	0 to 70	LVCE161284	<a href="#">Samples</a>
SN74LVCE161284DL	ACTIVE	SSOP	DL	48	25	RoHS & Green	NIPDAU	Level-1-260C-UNLIM	0 to 70	LVCE161284	<a href="#">Samples</a>
SN74LVCE161284DLR	ACTIVE	SSOP	DL	48	1000	RoHS & Green	NIPDAU	Level-1-260C-UNLIM	0 to 70	LVCE161284	<a href="#">Samples</a>

(1) The marketing status values are defined as follows:

**ACTIVE:** Product device recommended for new designs.

**LIFEBUY:** TI has announced that the device will be discontinued, and a lifetime-buy period is in effect.

**NRND:** Not recommended for new designs. Device is in production to support existing customers, but TI does not recommend using this part in a new design.

**PREVIEW:** Device has been announced but is not in production. Samples may or may not be available.

**OBSELETE:** TI has discontinued the production of the device.

(2) **RoHS:** TI defines "RoHS" to mean semiconductor products that are compliant with the current EU RoHS requirements for all 10 RoHS substances, including the requirement that RoHS substance do not exceed 0.1% by weight in homogeneous materials. Where designed to be soldered at high temperatures, "RoHS" products are suitable for use in specified lead-free processes. TI may reference these types of products as "Pb-Free".

**RoHS Exempt:** TI defines "RoHS Exempt" to mean products that contain lead but are compliant with EU RoHS pursuant to a specific EU RoHS exemption.

**Green:** TI defines "Green" to mean the content of Chlorine (Cl) and Bromine (Br) based flame retardants meet JS709B low halogen requirements of <=1000ppm threshold. Antimony trioxide based flame retardants must also meet the <=1000ppm threshold requirement.

(3) MSL, Peak Temp. - The Moisture Sensitivity Level rating according to the JEDEC industry standard classifications, and peak solder temperature.

(4) There may be additional marking, which relates to the logo, the lot trace code information, or the environmental category on the device.

(5) Multiple Device Markings will be inside parentheses. Only one Device Marking contained in parentheses and separated by a "-" will appear on a device. If a line is indented then it is a continuation of the previous line and the two combined represent the entire Device Marking for that device.

(6) Lead finish/Ball material - Orderable Devices may have multiple material finish options. Finish options are separated by a vertical ruled line. Lead finish/Ball material values may wrap to two lines if the finish value exceeds the maximum column width.

**Important Information and Disclaimer:**The information provided on this page represents TI's knowledge and belief as of the date that it is provided. TI bases its knowledge and belief on information provided by third parties, and makes no representation or warranty as to the accuracy of such information. Efforts are underway to better integrate information from third parties. TI has taken and

continues to take reasonable steps to provide representative and accurate information but may not have conducted destructive testing or chemical analysis on incoming materials and chemicals. TI and TI suppliers consider certain information to be proprietary, and thus CAS numbers and other limited information may not be available for release.

In no event shall TI's liability arising out of such information exceed the total purchase price of the TI part(s) at issue in this document sold by TI to Customer on an annual basis.

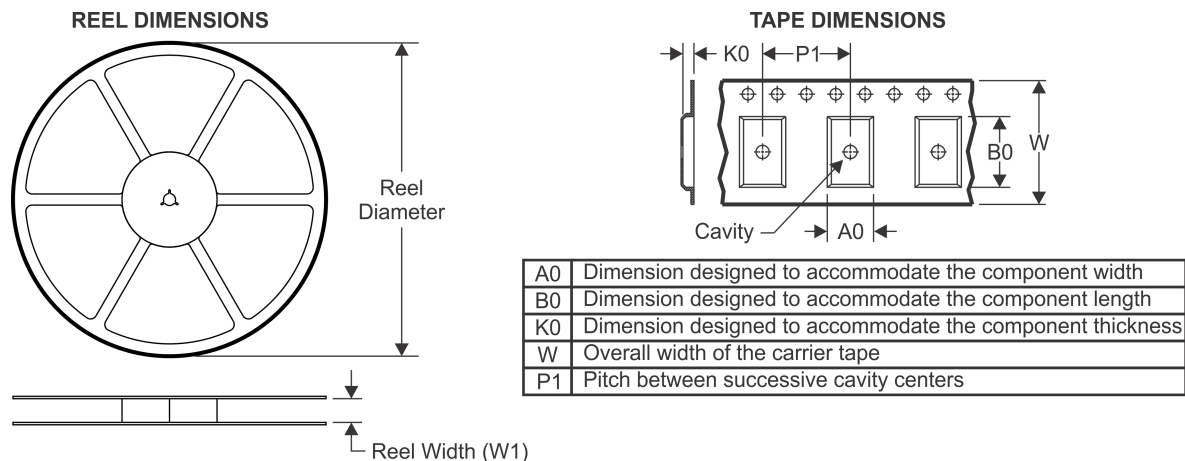
**TAPE AND REEL INFORMATION**

**QUADRANT ASSIGNMENTS FOR PIN 1 ORIENTATION IN TAPE**

\*All dimensions are nominal

Device	Package Type	Package Drawing	Pins	SPQ	Reel Diameter (mm)	Reel Width W1 (mm)	A0 (mm)	B0 (mm)	K0 (mm)	P1 (mm)	W (mm)	Pin1 Quadrant
SN74LVCE161284DGGR	TSSOP	DGG	48	2000	330.0	24.4	8.6	13.0	1.8	12.0	24.0	Q1
SN74LVCE161284DLR	SSOP	DL	48	1000	330.0	32.4	11.35	16.2	3.1	16.0	32.0	Q1

**TAPE AND REEL BOX DIMENSIONS**

\*All dimensions are nominal

Device	Package Type	Package Drawing	Pins	SPQ	Length (mm)	Width (mm)	Height (mm)
SN74LVCE161284DGGR	TSSOP	DGG	48	2000	367.0	367.0	45.0
SN74LVCE161284DLR	SSOP	DL	48	1000	367.0	367.0	55.0

**TUBE**

\*All dimensions are nominal

Device	Package Name	Package Type	Pins	SPQ	L (mm)	W (mm)	T (μm)	B (mm)
SN74LVCE161284DL	DL	SSOP	48	25	473.7	14.24	5110	7.87

# MECHANICAL DATA

DL (R-PDSO-G48)

PLASTIC SMALL-OUTLINE PACKAGE



- NOTES:
- All linear dimensions are in inches (millimeters).
  - This drawing is subject to change without notice.
  - Body dimensions do not include mold flash or protrusion not to exceed 0.006 (0,15).
  - Falls within JEDEC MO-118

PowerPAD is a trademark of Texas Instruments.



# EXAMPLE BOARD LAYOUT

DGG0048A

TSSOP - 1.2 mm max height

SMALL OUTLINE PACKAGE

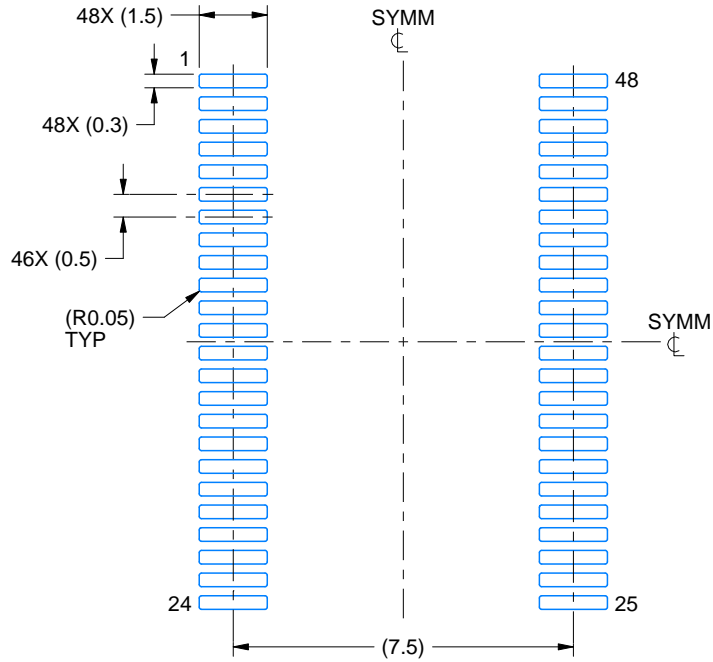

LAND PATTERN EXAMPLE  
SCALE:6X



SOLDER MASK DETAILS

4214859/B 11/2020

NOTES: (continued)

5. Publication IPC-7351 may have alternate designs.
6. Solder mask tolerances between and around signal pads can vary based on board fabrication site.

# EXAMPLE STENCIL DESIGN

DGG0048A

TSSOP - 1.2 mm max height

SMALL OUTLINE PACKAGE



SOLDER PASTE EXAMPLE  
BASED ON 0.125 mm THICK STENCIL  
SCALE:6X

4214859/B 11/2020

NOTES: (continued)

7. Laser cutting apertures with trapezoidal walls and rounded corners may offer better paste release. IPC-7525 may have alternate design recommendations.
8. Board assembly site may have different recommendations for stencil design.

DGG (R-PDSO-G\*\*)

PLASTIC SMALL-OUTLINE PACKAGE

48 PINS SHOWN



- NOTES: A. All linear dimensions are in millimeters.  
 B. This drawing is subject to change without notice.  
 C. Body dimensions do not include mold protrusion not to exceed 0,15.  
 D. Falls within JEDEC MO-153

## IMPORTANT NOTICE AND DISCLAIMER

TI PROVIDES TECHNICAL AND RELIABILITY DATA (INCLUDING DATA SHEETS), DESIGN RESOURCES (INCLUDING REFERENCE DESIGNS), APPLICATION OR OTHER DESIGN ADVICE, WEB TOOLS, SAFETY INFORMATION, AND OTHER RESOURCES "AS IS" AND WITH ALL FAULTS, AND DISCLAIMS ALL WARRANTIES, EXPRESS AND IMPLIED, INCLUDING WITHOUT LIMITATION ANY IMPLIED WARRANTIES OF MERCHANTABILITY, FITNESS FOR A PARTICULAR PURPOSE OR NON-INFRINGEMENT OF THIRD PARTY INTELLECTUAL PROPERTY RIGHTS.

These resources are intended for skilled developers designing with TI products. You are solely responsible for (1) selecting the appropriate TI products for your application, (2) designing, validating and testing your application, and (3) ensuring your application meets applicable standards, and any other safety, security, regulatory or other requirements.

These resources are subject to change without notice. TI grants you permission to use these resources only for development of an application that uses the TI products described in the resource. Other reproduction and display of these resources is prohibited. No license is granted to any other TI intellectual property right or to any third party intellectual property right. TI disclaims responsibility for, and you will fully indemnify TI and its representatives against, any claims, damages, costs, losses, and liabilities arising out of your use of these resources.

TI's products are provided subject to [TI's Terms of Sale](#) or other applicable terms available either on [ti.com](http://ti.com) or provided in conjunction with such TI products. TI's provision of these resources does not expand or otherwise alter TI's applicable warranties or warranty disclaimers for TI products.

TI objects to and rejects any additional or different terms you may have proposed.

Mailing Address: Texas Instruments, Post Office Box 655303, Dallas, Texas 75265  
Copyright © 2022, Texas Instruments Incorporated