

TLV3502-Q1, 4.5-ns Rail-to-Rail High-Speed Comparator

1 Features

- Qualified for Automotive Applications
- AEC-Q100 Qualified With the Following Results:
 - Device Temperature Grade 1: -40°C to $+125^{\circ}\text{C}$ Ambient Operating Temperature Range
 - Device HBM ESD Classification Level 2
 - Device CDM ESD Classification Level C4B
- High Speed: 4.5 ns
- Rail-To-Rail I/O
- Supply Voltage: 2.7 V To 5.5 V
- Push-Pull CMOS Output Stage
- Shutdown
- Micro Package: SOT23-8
- Low Supply Current: 3.2 mA

2 Applications

- HEV/EV, Powertrain, and Passive Safety:
 - Threshold Detector
 - Zero-Crossing Detector
 - Window Comparator
 - Oscillator

3 Description

The TLV3502-Q1 push-pull output comparators feature a fast 4.5-ns propagation delay and operation from 2.7 V to 5.5 V. Beyond-the-rails input common-mode range makes the device an ideal choice for low-voltage applications. The rail-to-rail output directly drives either CMOS or TTL logic.

A microsize package provides options for portable and space-restricted applications. The TLV3502-Q1 device is available in the SOT23-8 (DCN) package.

Device Information⁽¹⁾

PART NUMBER	PACKAGE	BODY SIZE (NOM)
TLV3502-Q1	SOT-23 (8)	2.90 mm x 1.60 mm

(1) For all available packages, see the orderable addendum at the end of the datasheet.

Propagation Delay vs Overdrive Voltage

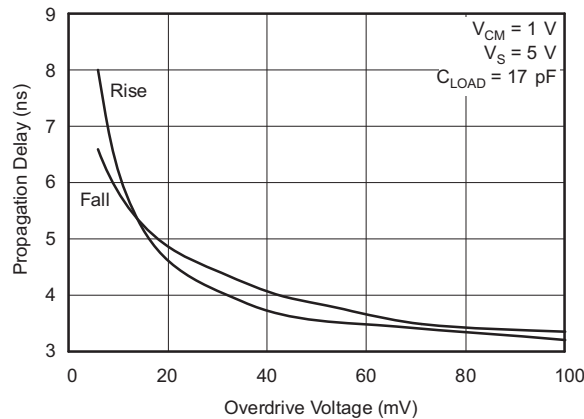

Table of Contents

1 Features	1	7.2 Functional Block Diagram	9
2 Applications	1	7.3 Feature Description	9
3 Description	1	7.4 Device Functional Modes	11
4 Revision History	2	8 Application and Implementation	12
5 Pin Configuration and Functions	3	8.1 Application Information	12
6 Specifications	4	8.2 Typical Application	12
6.1 Absolute Maximum Ratings	4	9 Power Supply Recommendations	13
6.2 ESD Ratings	4	10 Layout	13
6.3 Recommended Operating Conditions	4	10.1 Layout Guidelines	13
6.4 Thermal Information	4	10.2 Layout Example	14
6.5 Electrical Characteristics	5	11 Device and Documentation Support	16
6.6 Switching Characteristics	5	11.1 Trademarks	16
6.7 Typical Characteristics	6	11.2 Electrostatic Discharge Caution	16
7 Detailed Description	9	11.3 Glossary	16
7.1 Overview	9	12 Mechanical, Packaging, and Orderable Information	16

4 Revision History

Changes from Original (February 2010) to Revision A	Page
• Deleted references to the TLV3501 device and changed the TLV3502 device name to TLV3502-Q1	1
• Added <i>ESD Ratings</i> table, <i>Feature Description</i> section, <i>Device Functional Modes</i> , <i>Application and Implementation</i> section, <i>Power Supply Recommendations</i> section, <i>Layout</i> section, <i>Device and Documentation Support</i> section, and <i>Mechanical, Packaging, and Orderable Information</i> section	4

5 Pin Configuration and Functions

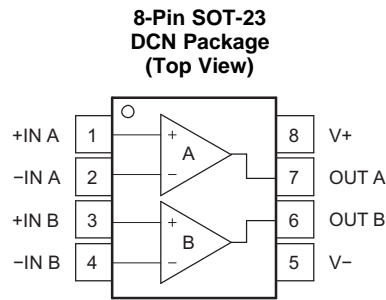

Pin Functions

PIN		TYPE	DESCRIPTION
NO.	NAME		
1	+IN A	I	Non inverting input, channel A
2	-IN A	I	Inverting input, channel A
3	+IN B	I	Non inverting input, channel B
4	-IN B	I	Inverting input, channel B
5	V-	Supply	Negative (lowest) power supply
6	OUT B	O	Output, channel B
7	OUT A	O	Output, channel A
8	V+	Supply	Positive (highest) power supply

6 Specifications

6.1 Absolute Maximum Ratings

over operating free-air temperature range (unless otherwise noted) ⁽¹⁾

	MIN	MAX	UNIT
Supply voltage		5.5	V
Signal input terminal voltage ⁽²⁾	(V-) – 0.3	(V+) + 0.3	V
Signal input terminal current ⁽²⁾		10	mA
Output short-circuit current ⁽³⁾		74	mA
Thermal impedance, junction to free air	200	200	°C/W
Operating temperature	–40	125	°C
Junction temperature		150	°C
Storage temperature, T _{stg}	–65	150	°C

- (1) Stresses beyond those listed under *Absolute Maximum Ratings* may cause permanent damage to the device. These are stress ratings only, which do not imply functional operation of the device at these or any other conditions beyond those indicated under *Recommended Operating Conditions*. Exposure to absolute-maximum-rated conditions for extended periods may affect device reliability.
- (2) Input terminals are diode-clamped to the power-supply rails. Input signals that can swing more than 0.3 V beyond the supply rails should be current limited to 10mA or less.
- (3) Short circuit to ground, one comparator per package

6.2 ESD Ratings

		VALUE	UNIT	
V _(ESD) Electrostatic discharge	Human body model (HBM), per AEC Q100-002 ⁽¹⁾	±2000	V	
	Charged device model (CDM), per AEC Q100-011	Corner pins (+IN A, –IN B, V+, and V–)		±750
		Other pins		±500

- (1) AEC Q100-002 indicates HBM stressing is done in accordance with the ANSI/ESDA/JEDEC JS-001 specification.

6.3 Recommended Operating Conditions

over operating free-air temperature range (unless otherwise noted)

		MIN	NOM	MAX	UNIT
V _S	Supply voltage	2.2	2.7	5.5	V
V _{IL}	Low-level input voltage, shutdown (comparator is enabled) ⁽¹⁾			(V+) – 1.7	V
V _{IH}	High-level input voltage, shutdown (comparator is disabled) ⁽¹⁾	(V+) – 0.9			V
T _A	Operating temperature	–40		125	°C

- (1) When the shutdown pin is within 0.9 V of the most positive supply, the part is disabled. When it is more than 1.7 V below the most positive supply, the part is enabled.

6.4 Thermal Information

THERMAL METRIC ⁽¹⁾		TLV3502-Q1	UNIT
		SOT-23	
		8 PINS	
R _{θJA}	Junction-to-ambient thermal resistance	191.6	°C/W
R _{θJC(top)}	Junction-to-case (top) thermal resistance	43.9	
R _{θJB}	Junction-to-board thermal resistance	120.3	
ψ _{JT}	Junction-to-top characterization parameter	14.4	
ψ _{JB}	Junction-to-board characterization parameter	118.6	

- (1) For more information about traditional and new thermal metrics, see the *IC Package Thermal Metrics* application report, [SPRA953](#).

6.5 Electrical Characteristics

 $T_A = 25^\circ\text{C}$ and $V_S = 2.7\text{ V}$ to 5.5 V (unless otherwise noted)

PARAMETER		TEST CONDITIONS	MIN	TYP	MAX	UNIT
V_{OS}	Input offset voltage ⁽¹⁾	$V_{CM} = 0\text{ V}$, $I_O = 0\text{ mA}$		± 1	± 6.5	mV
$\Delta V_{OS}/\Delta T$	Offset voltage vs temperature	$T_A = -40^\circ\text{C}$ to 125°C		± 5		$\mu\text{V}/^\circ\text{C}$
PSRR	Offset voltage vs power supply	$V_S = 2.7\text{ V}$ to 5.5 V		100	400	$\mu\text{V}/\text{V}$
	Input hysteresis			6		mV
I_B	Input bias current	$V_{CM} = V_{CC}/2$, $\Delta V_{IN} = \pm 5.5\text{ V}$		± 2	± 10	pA
I_{OS}	Input offset current ⁽²⁾	$V_{CM} = V_{CC}/2$, $\Delta V_{IN} = \pm 5.5\text{ V}$		± 2	± 10	pA
V_{CM}	Common-mode voltage range		(V-) - 0.2		(V+) + 0.2	V
CMRR	Common-mode rejection	$V_{CM} = -0.2\text{ V}$ to (V+) + 0.2 V	57	70		dB
		$T_A = -40^\circ\text{C}$ to 125°C $V_{CM} = -0.2\text{ V}$ to (V+) + 0.2 V	55			
	Common-mode input impedance			$10^{13} \parallel 2$		$\Omega \parallel \text{pF}$
	Differential input impedance			$10^{13} \parallel 4$		$\Omega \parallel \text{pF}$
V_{OH}	High-level voltage output from rail	$I_{OUT} = \pm 1\text{ mA}$		30	50	mV
V_{OL}	Low-level voltage output from rail	$I_{OUT} = \pm 1\text{ mA}$		30	50	mV
	Input bias current of shutdown pin			2		pA
I_Q	Quiescent current per comparator	$V_S = 5\text{ V}$, $V_O = \text{High}$		3.2	5	mA
$I_{Q(SD)}$	Quiescent current in shutdown			2		μA

(1) V_{OS} is defined as the average of the positive and the negative switching thresholds.

(2) The difference between I_{B+} and I_{B-} .

6.6 Switching Characteristics

 $T_A = 25^\circ\text{C}$ and $V_S = 2.7\text{ V}$ to 5.5 V (unless otherwise noted)

PARAMETER		TEST CONDITIONS	MIN	TYP	MAX	UNIT
t_{pd}	Propagation delay time ⁽¹⁾⁽²⁾	$\Delta V_{IN} = 100\text{ mV}$, Overdrive = 20 mV		4.5	6.4	ns
		$T_A = -40^\circ\text{C}$ to 125°C $\Delta V_{IN} = 100\text{ mV}$, Overdrive = 20 mV			7	ns
		$\Delta V_{IN} = 100\text{ mV}$, Overdrive = 5 mV		7.5	10	ns
		$T_A = -40^\circ\text{C}$ to 125°C $\Delta V_{IN} = 100\text{ mV}$, Overdrive = 5 mV			12	ns
$\Delta t_{(SKEW)}$	Propagation delay skew ⁽³⁾	$\Delta V_{IN} = 100\text{ mV}$, Overdrive = 20 mV		0.5		ns
f_{MAX}	Maximum toggle frequency	Overdrive = 50 mV, $V_S = 5\text{ V}$		80		MHz
t_R	Rise time ⁽⁴⁾			1.5		ns
t_F	Fall time ⁽⁴⁾			1.5		ns
t_{OFF}	Shutdown turn-off time			30		ns
t_{ON}	Shutdown turn-on time			100		ns

(1) Propagation delay cannot be accurately measured with low overdrive on automatic test equipment. This parameter is ensured by characterization at 100-mV overdrive.

(2) Not production tested

(3) The difference between the propagation delay going high and the propagation delay going low.

(4) Measured between 10% of V_S and 90% of V_S .

6.7 Typical Characteristics

$T_A = 25^\circ\text{C}$, $V_S = 5\text{ V}$, Input Overdrive = 100 mV (unless otherwise noted)

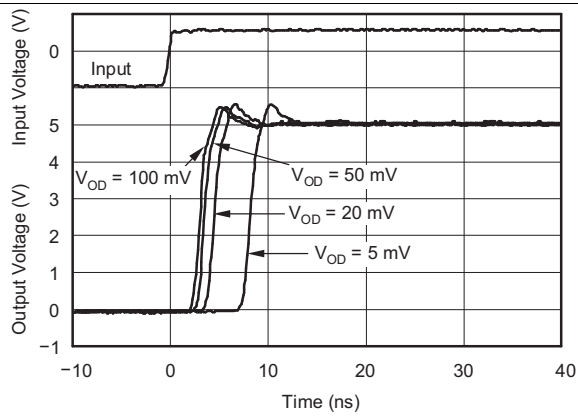

Figure 1. Output Response for Various Overdrive Voltages (rising)

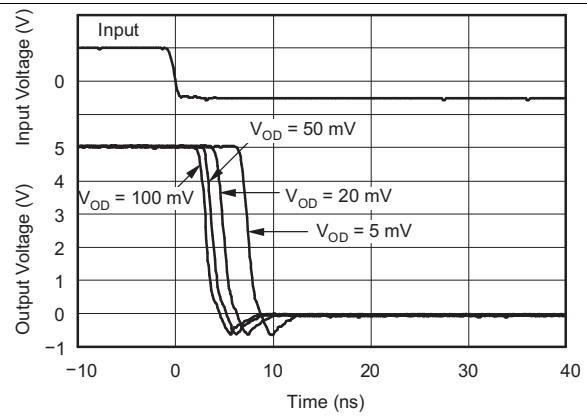

Figure 2. Output Response for Various Overdrive Voltages (falling)

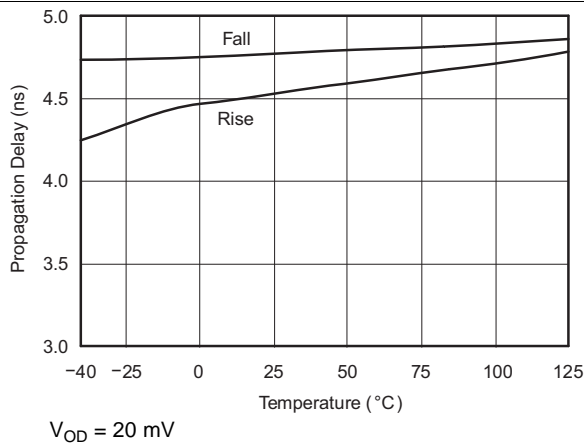

Figure 3. Propagation Delay vs Temperature

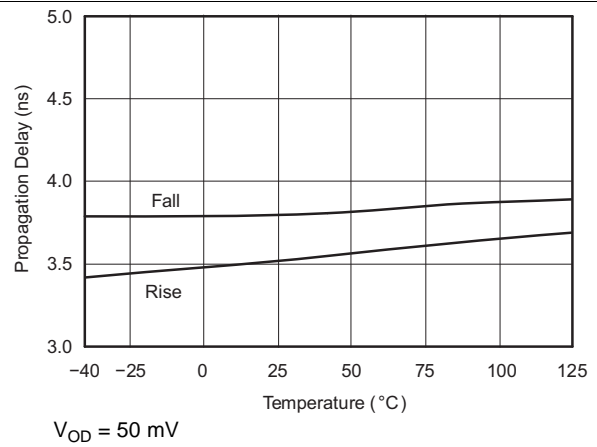

Figure 4. Propagation Delay vs Temperature

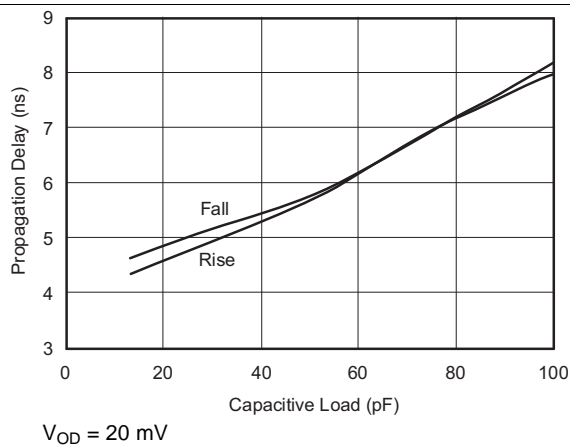

Figure 5. Propagation Delay vs Capacitive Load

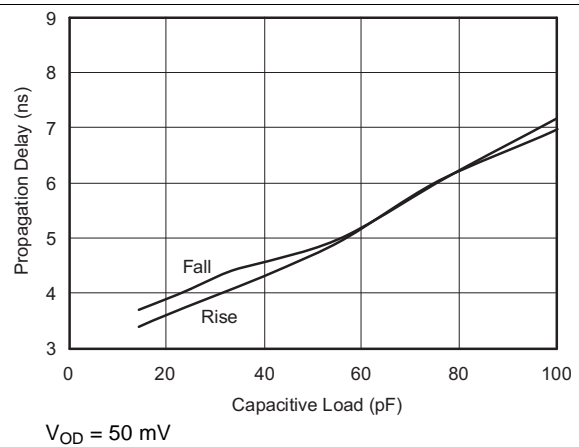

Figure 6. Propagation Delay vs Capacitive Load

Typical Characteristics (continued)

$T_A = 25^\circ\text{C}$, $V_S = 5\text{ V}$, Input Overdrive = 100 mV (unless otherwise noted)

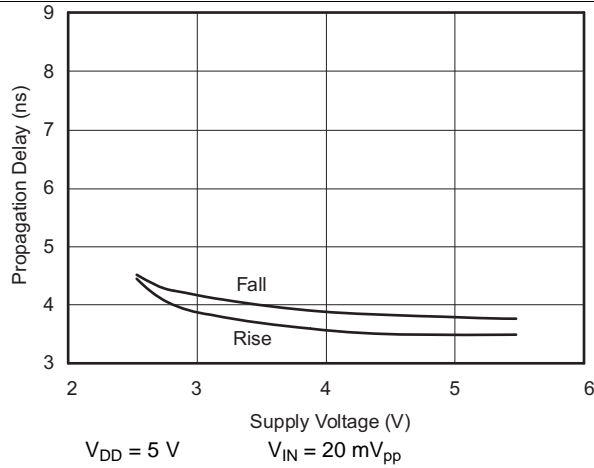

Figure 7. Propagation Delay vs Supply Voltage

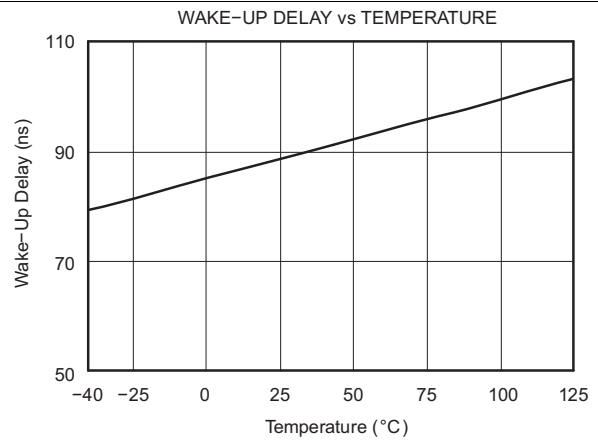

Figure 8. Wake-Up Delay vs Temperature

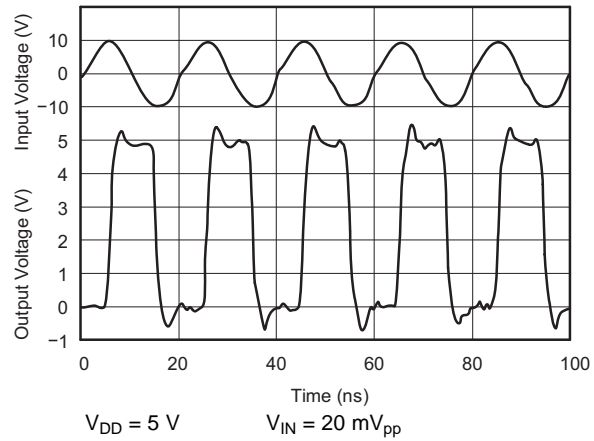

Figure 9. Response to 50-MHz Sine Wave

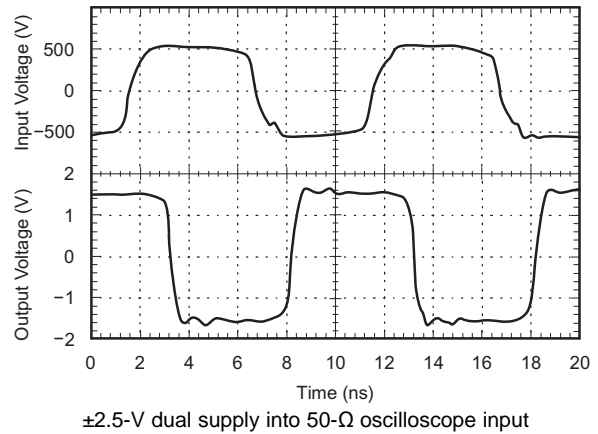

Figure 10. Response to 100 MHz Sine Wave

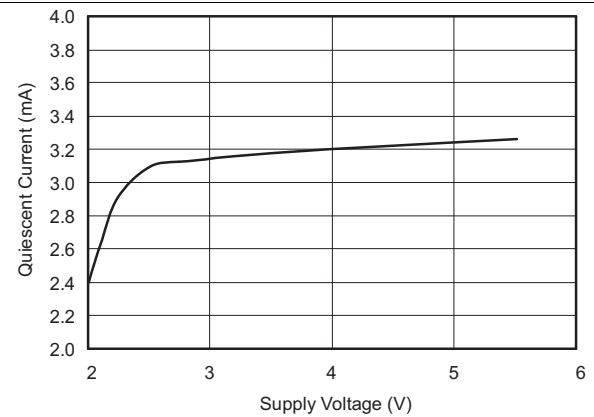

Figure 11. Quiescent Current vs Supply Voltage

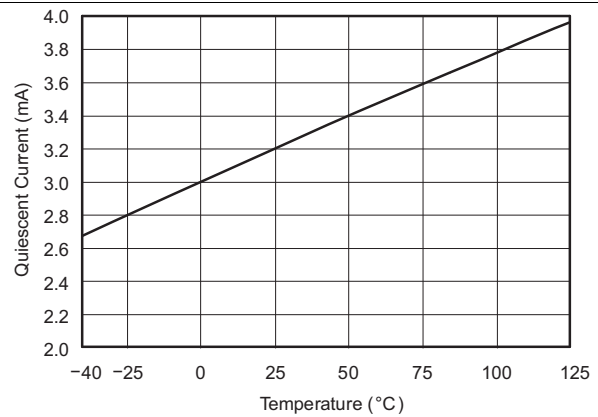

Figure 12. Quiescent Current vs Temperature

Typical Characteristics (continued)

$T_A = 25^\circ\text{C}$, $V_S = 5\text{ V}$, Input Overdrive = 100 mV (unless otherwise noted)

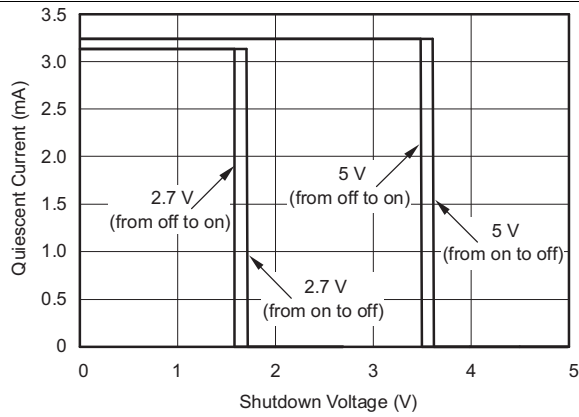

Figure 13. Quiescent Current vs Shutdown Voltage

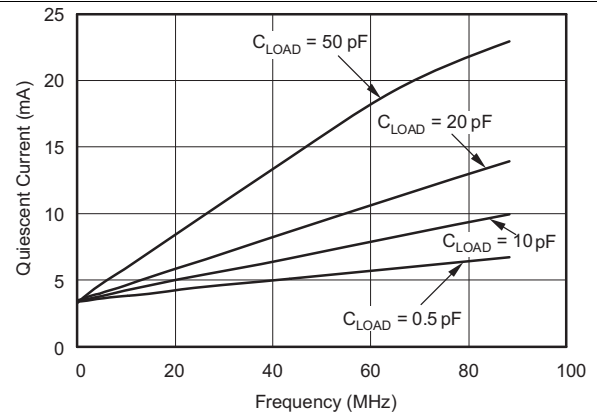

Figure 14. Quiescent Current vs Frequency

7 Detailed Description

7.1 Overview

The TLV3502-Q1 push-pull output comparator features a fast 4.5-ns propagation delay and operation from 2.7 V to 5.5 V. Beyond-the-rails input common-mode range makes it an ideal choice for low-voltage applications. The rail-to-rail output directly drives either CMOS or TTL logic.

7.2 Functional Block Diagram

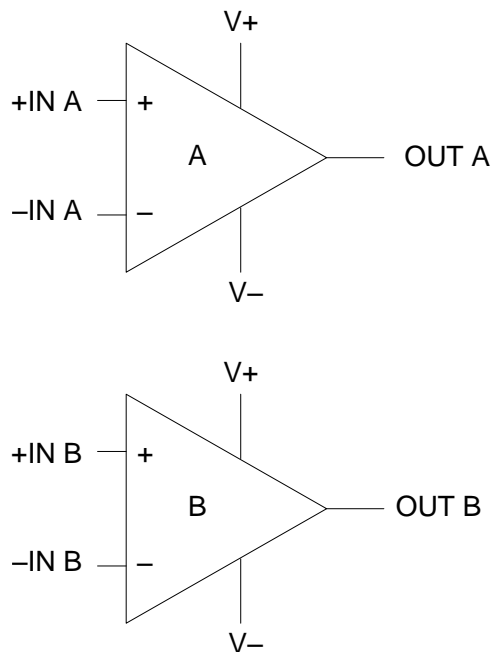

7.3 Feature Description

The TLV3502-Q1 device feature fast 4.5-ns propagation delay with a push-pull output. The device operates from 2.7 V to 5.5 V. It has beyond-the-rails input common-mode range and rail-to-rail output directly drives either CMOS or TTL logic.

7.3.1 Input Over-Voltage Protection

Device inputs are protected by ESD diodes that will conduct if the input voltages exceed the power supplies by more than approximately 300 mV. Momentary voltages greater than 300 mV beyond the power supply can be tolerated if the input current is limited to 10 mA. This limiting is easily accomplished with a small input resistor in series with the comparator, as shown in [Figure 15](#).

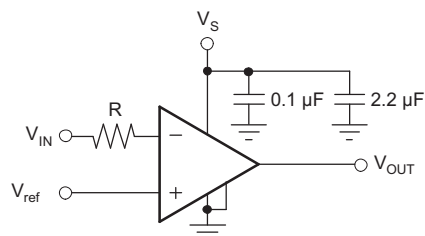

Figure 15. Input Current Protection for Voltages Exceeding the Supply Voltage

Feature Description (continued)

7.3.2 Relaxation Oscillator

The TLV350x can easily be configured as a simple and inexpensive relaxation oscillator. In [Figure 16](#), the R2 network sets the trip threshold at 1/3 and 2/3 of the supply. Since this is a high-speed circuit, the resistor values are rather low to minimize the effect of parasitic capacitance. The positive input alternates between 1/3 of V+ and 2/3 of V+ depending on whether the output is low or high. The time to charge (or discharge) is $0.69R_1C$. Therefore, the period is $1.38R_1C$. For 62 pF and 1 kΩ as shown in [Figure 16](#), the output is calculated to be 10.9MHz. An implementation of this circuit oscillated at 9.6 MHz. Parasitic capacitance and component tolerances explain the difference between theory and actual performance.

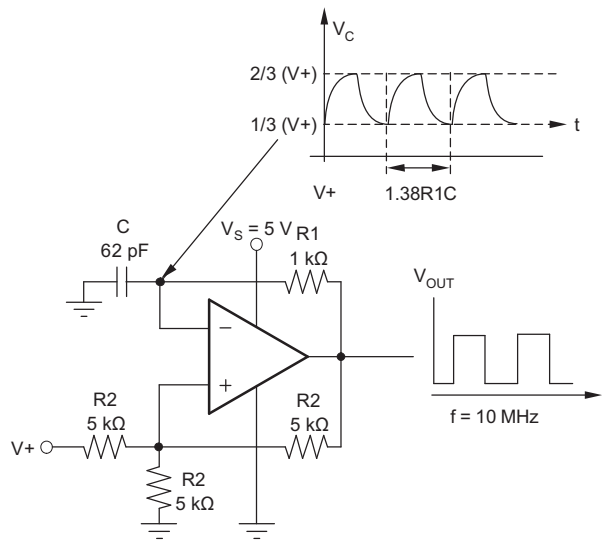

Figure 16. Relaxation Oscillator

7.3.3 High-Speed Window Comparator

A window comparator circuit is used to determine when a signal is between two voltages. The TLV3502-Q1 device can readily be used to create a high-speed window comparator. V_{HI} is the upper voltage threshold, and V_{LO} is the lower voltage threshold. When V_{IN} is between these two thresholds, the output in [Figure 17](#) is high. [Figure 18](#) shows a simple means of obtaining an active low output. Note that the reference levels are connected differently between [Figure 17](#) and [Figure 18](#). The operating voltage range of either circuit is 2.7 V to 5.5 V.

Feature Description (continued)

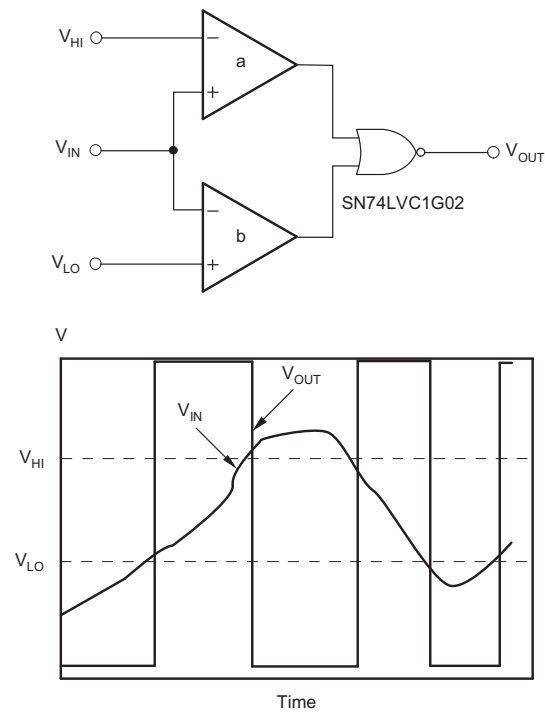

Figure 17. Window Comparator—Active High

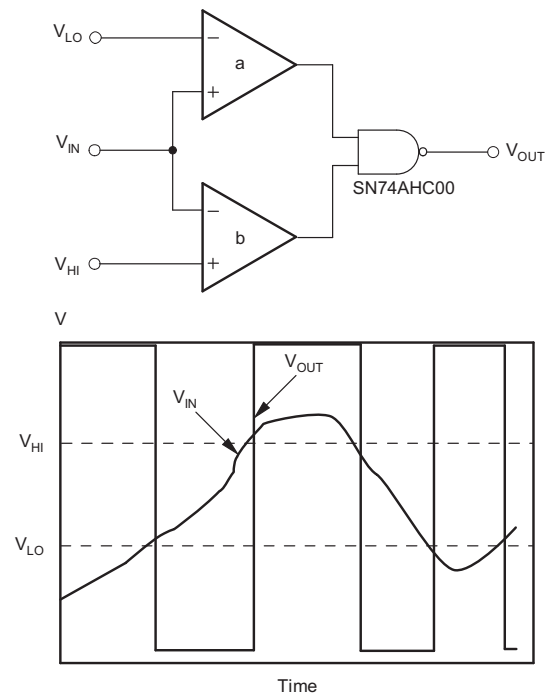

Figure 18. Window Comparator—Active Low

7.4 Device Functional Modes

This device has no special operating modes outside of the normally powered dual comparator function.

8 Application and Implementation

NOTE

Information in the following applications sections is not part of the TI component specification, and TI does not warrant its accuracy or completeness. TI's customers are responsible for determining suitability of components for their purposes. Customers should validate and test their design implementation to confirm system functionality.

8.1 Application Information

The TLV3502-Q1 device features high-speed response and includes 6 mV of internal hysteresis for improved noise immunity with an input common-mode range that extends 0.2 V beyond the power-supply rails.

8.2 Typical Application

In this example, we will show how can we add external hysteresis to TLV3502-Q1 device to achieve greater noise immunity. First, let's understand when and why external hysteresis may be required.

The TLV3502-Q1 device has a robust performance when used with a good layout. However, comparator inputs have little noise immunity within the range of specified offset voltage (± 5 mV). For slow moving or noisy input signals, the comparator output may display multiple switching as input signals move through the switching threshold. In such applications, the 6mV of internal hysteresis of the TLV3502-Q1 device might not be sufficient. In cases where greater noise immunity is desired, external hysteresis may be added by connecting a small amount of feedback to the positive input.

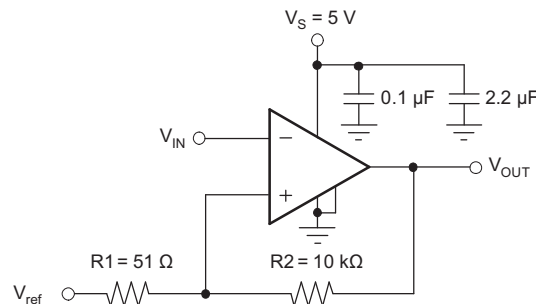

Figure 19. Application Adding Hysteresis to the TLV350x

8.2.1 Design Requirements

Figure 19 shows a typical topology used to introduce 25 mV of additional hysteresis, for a total of 31-mV hysteresis when operating from a single 5-V supply.

8.2.2 Detailed Design Procedure

Use Equation 1 to calculate the total hysteresis.

$$V_{\text{HYST}} = \frac{(V_{+}) \times R1}{R1 + R2} + 6 \text{ mV} \quad (1)$$

V_{HYST} sets the value of the transition voltage required to switch the comparator output by enlarging the threshold region, thereby reducing sensitivity to noise.

Typical Application (continued)

8.2.3 Application Curve

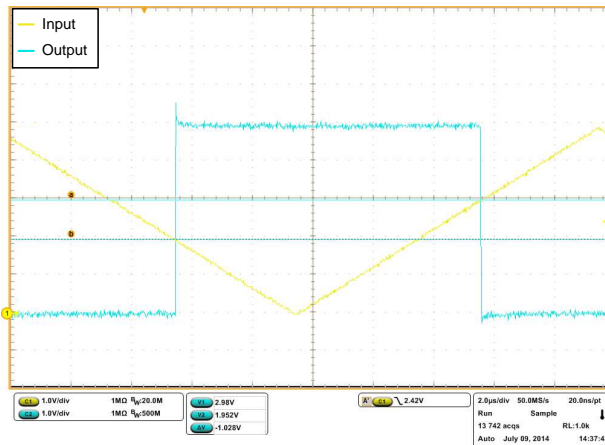

Figure 20. TLV3502 With Upper and Lower Threshold With 1-V Hysteresis

9 Power Supply Recommendations

The TLV3505-Q1 comparator is specified for use on a single supply from 2.7 V to 5.5 V (or a dual supply from ± 1.35 V to ± 2.75 V) over a temperature range of -40°C to 125°C . The device continues to function below this range, but performance is not specified.

Place bypass capacitors close to the power supply pins to reduce noise coupling in from noisy or high-impedance power supplies. For more detailed information on bypass capacitor placement, see the [Layout Guidelines](#) section.

10 Layout

10.1 Layout Guidelines

- For any high-speed comparator or amplifier, proper design and printed circuit board (PCB) layout are necessary for optimal performance. Excess stray capacitance on the active input, or improper grounding, can limit the maximum performance of high-speed circuitry.
- Minimizing resistance from the signal source to the comparator input is necessary in order to minimize the propagation delay of the complete circuit. The source resistance along with input and stray capacitance creates an RC filter that delays voltage transitions at the input, and reduces the amplitude of high-frequency signals. The input capacitance of the TLV3502-Q1 device along with stray capacitance from an input pin to ground results in several picofarads of capacitance.
- The location and type of capacitors used for power-supply bypassing are critical to high-speed comparators. The suggested 2.2- μF tantalum capacitor do not need to be as close to the device as the 0.1- μF capacitor, and may be shared with other devices. The 2.2- μF capacitor buffers the power-supply line against ripple, and the 0.1- μF capacitor provides a charge for the comparator during high frequency switching.
- In a high-speed circuit, fast rising and falling switching transients create voltage differences across lines that would be at the same potential at DC. To reduce this effect, a ground plane is often used to reduce difference in voltage potential within the circuit board. A ground plane has the advantage of minimizing the effect of stray capacitances on the circuit board by providing a more desirable path for the current to flow. With a signal trace over a ground plane, at high-frequency the return current (in the ground plane) tends to flow right under the signal trace. Breaks in the ground plane (as simple as through-hole leads and vias) increase the inductance of the plane, making it less effective at higher frequencies. Breaks in the ground plane for necessary vias should be spaced randomly.
- [Figure 21](#) shows an evaluation layout for the TLV3502-Q1 SOT23-8 package. The device is shown with SMA connectors bringing signals on and off the board. RT1, RT2, RT3 and RT4 are termination resistors for + IN A, + IN B, -IN A, and -IN B respectively. C1 and C2 are power-supply bypass capacitors. Place the 0.1- μF capacitor closest to the comparator. The ground plane is not shown, but the pads that the resistors and capacitors connect to are shown. [Figure 22](#) shows a schematic of this circuit.

10.2 Layout Example

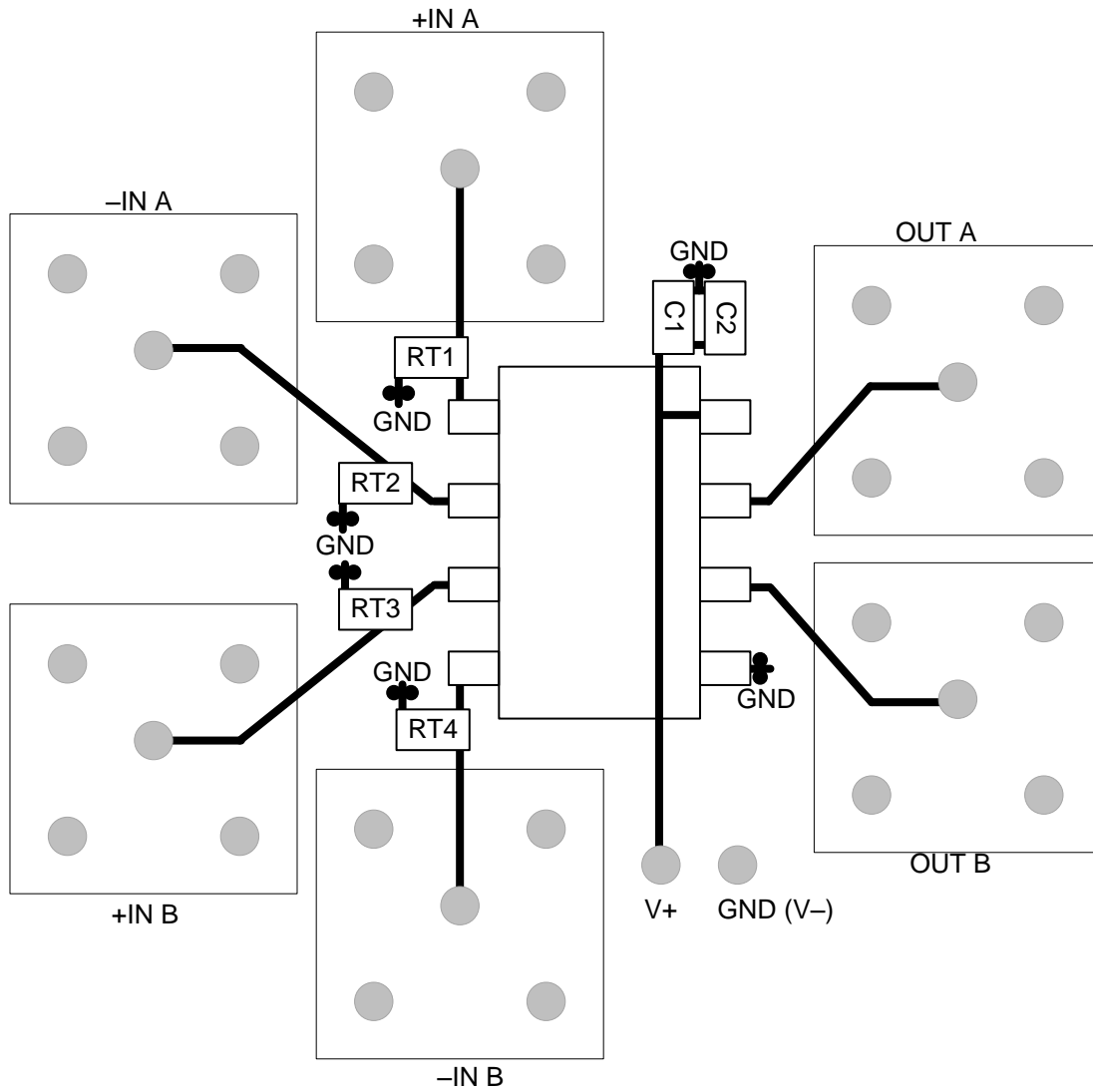

Figure 21. TLV3502-Q1 Sample Layout

Layout Example (continued)

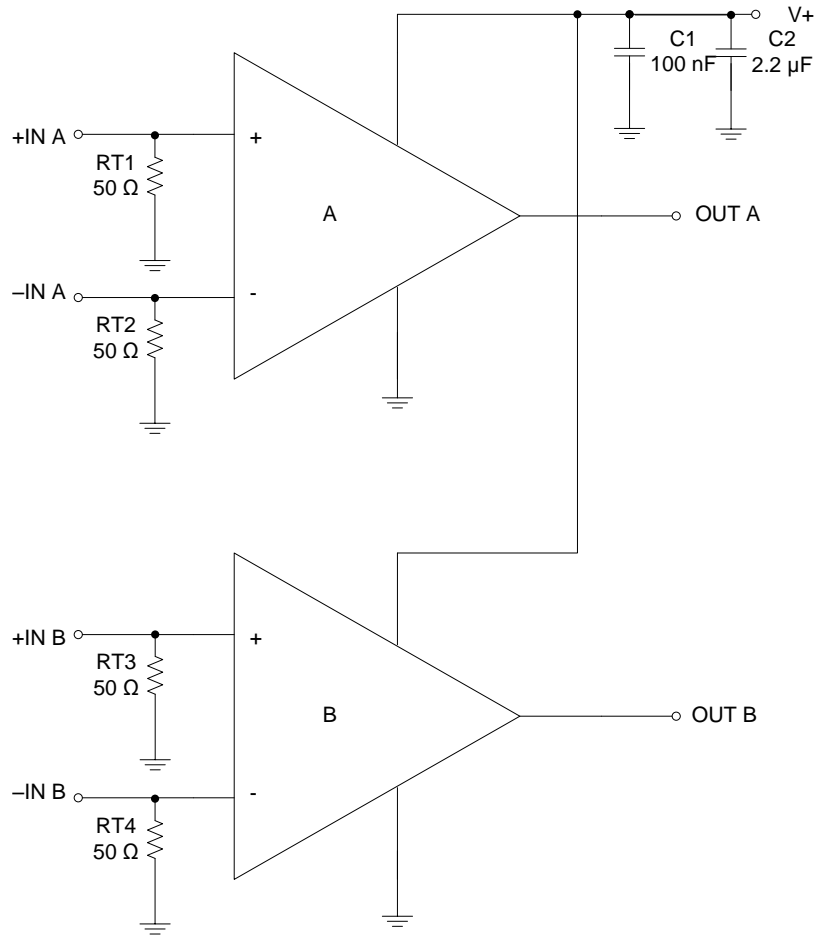

Figure 22. Schematic for [Figure 21](#)

11 Device and Documentation Support

11.1 Trademarks

All trademarks are the property of their respective owners.

11.2 Electrostatic Discharge Caution



These devices have limited built-in ESD protection. The leads should be shorted together or the device placed in conductive foam during storage or handling to prevent electrostatic damage to the MOS gates.

11.3 Glossary

[SLYZ022](#) — *TI Glossary*.

This glossary lists and explains terms, acronyms, and definitions.

12 Mechanical, Packaging, and Orderable Information

The following pages include mechanical, packaging, and orderable information. This information is the most current data available for the designated devices. This data is subject to change without notice and revision of this document. For browser-based versions of this data sheet, refer to the left-hand navigation.

PACKAGING INFORMATION

Orderable Device	Status (1)	Package Type	Package Drawing	Pins	Package Qty	Eco Plan (2)	Lead finish/ Ball material (6)	MSL Peak Temp (3)	Op Temp (°C)	Device Marking (4/5)	Samples
TLV3502AQDCNRQ1	ACTIVE	SOT-23	DCN	8	3000	RoHS & Green	NIPDAU	Level-2-260C-1 YEAR	-40 to 125	3502	Samples

(1) The marketing status values are defined as follows:

ACTIVE: Product device recommended for new designs.

LIFEBUY: TI has announced that the device will be discontinued, and a lifetime-buy period is in effect.

NRND: Not recommended for new designs. Device is in production to support existing customers, but TI does not recommend using this part in a new design.

PREVIEW: Device has been announced but is not in production. Samples may or may not be available.

OBSELETE: TI has discontinued the production of the device.

(2) **RoHS:** TI defines "RoHS" to mean semiconductor products that are compliant with the current EU RoHS requirements for all 10 RoHS substances, including the requirement that RoHS substance do not exceed 0.1% by weight in homogeneous materials. Where designed to be soldered at high temperatures, "RoHS" products are suitable for use in specified lead-free processes. TI may reference these types of products as "Pb-Free".

RoHS Exempt: TI defines "RoHS Exempt" to mean products that contain lead but are compliant with EU RoHS pursuant to a specific EU RoHS exemption.

Green: TI defines "Green" to mean the content of Chlorine (Cl) and Bromine (Br) based flame retardants meet JS709B low halogen requirements of <=1000ppm threshold. Antimony trioxide based flame retardants must also meet the <=1000ppm threshold requirement.

(3) MSL, Peak Temp. - The Moisture Sensitivity Level rating according to the JEDEC industry standard classifications, and peak solder temperature.

(4) There may be additional marking, which relates to the logo, the lot trace code information, or the environmental category on the device.

(5) Multiple Device Markings will be inside parentheses. Only one Device Marking contained in parentheses and separated by a "-" will appear on a device. If a line is indented then it is a continuation of the previous line and the two combined represent the entire Device Marking for that device.

(6) Lead finish/Ball material - Orderable Devices may have multiple material finish options. Finish options are separated by a vertical ruled line. Lead finish/Ball material values may wrap to two lines if the finish value exceeds the maximum column width.

Important Information and Disclaimer:The information provided on this page represents TI's knowledge and belief as of the date that it is provided. TI bases its knowledge and belief on information provided by third parties, and makes no representation or warranty as to the accuracy of such information. Efforts are underway to better integrate information from third parties. TI has taken and continues to take reasonable steps to provide representative and accurate information but may not have conducted destructive testing or chemical analysis on incoming materials and chemicals. TI and TI suppliers consider certain information to be proprietary, and thus CAS numbers and other limited information may not be available for release.

In no event shall TI's liability arising out of such information exceed the total purchase price of the TI part(s) at issue in this document sold by TI to Customer on an annual basis.

OTHER QUALIFIED VERSIONS OF TLV3502-Q1 :

- Catalog: [TLV3502](#)

NOTE: Qualified Version Definitions:

- Catalog - TI's standard catalog product

TAPE AND REEL INFORMATION



QUADRANT ASSIGNMENTS FOR PIN 1 ORIENTATION IN TAPE



*All dimensions are nominal

Device	Package Type	Package Drawing	Pins	SPQ	Reel Diameter (mm)	Reel Width W1 (mm)	A0 (mm)	B0 (mm)	K0 (mm)	P1 (mm)	W (mm)	Pin1 Quadrant
TLV3502AQDCNRQ1	SOT-23	DCN	8	3000	179.0	8.4	3.2	3.2	1.4	4.0	8.0	Q3

TAPE AND REEL BOX DIMENSIONS



*All dimensions are nominal

Device	Package Type	Package Drawing	Pins	SPQ	Length (mm)	Width (mm)	Height (mm)
TLV3502AQDCNRQ1	SOT-23	DCN	8	3000	213.0	191.0	35.0

DCN (R-PDSO-G8)

PLASTIC SMALL-OUTLINE PACKAGE (DIE DOWN)

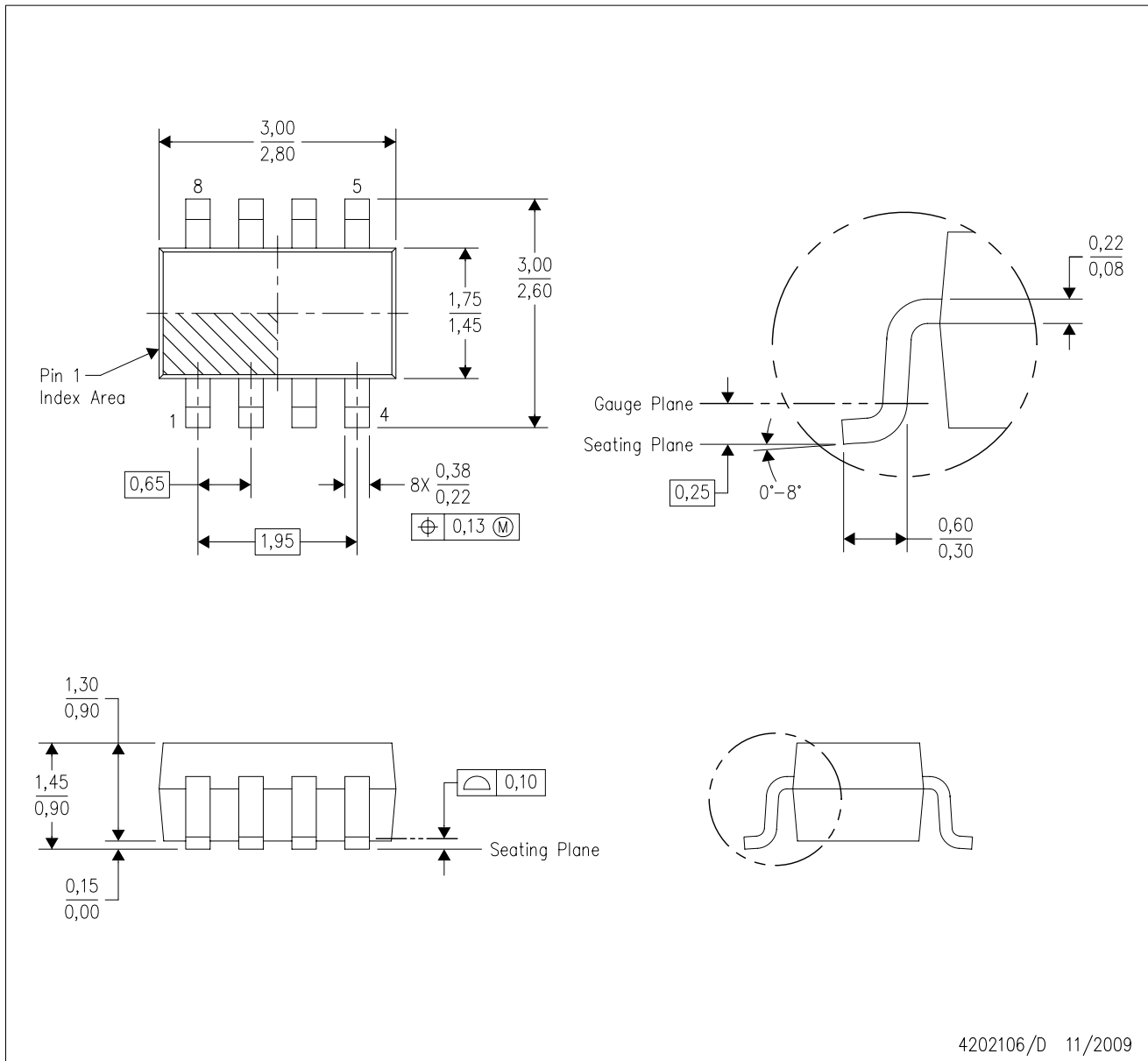

- NOTES:
- A. All linear dimensions are in millimeters.
 - B. This drawing is subject to change without notice.
 - C. Package outline exclusive of metal burr & dambar protrusion/intrusion.
 - D. Package outline inclusive of solder plating.
 - E. A visual index feature must be located within the Pin 1 index area.
 - F. Falls within JEDEC MO-178 Variation BA.
 - G. Body dimensions do not include flash or protrusion. Mold flash and protrusion shall not exceed 0.25 per side.

DCN (R-PDSO-G8)

PLASTIC SMALL-OUTLINE PACKAGE (DIE DOWN)

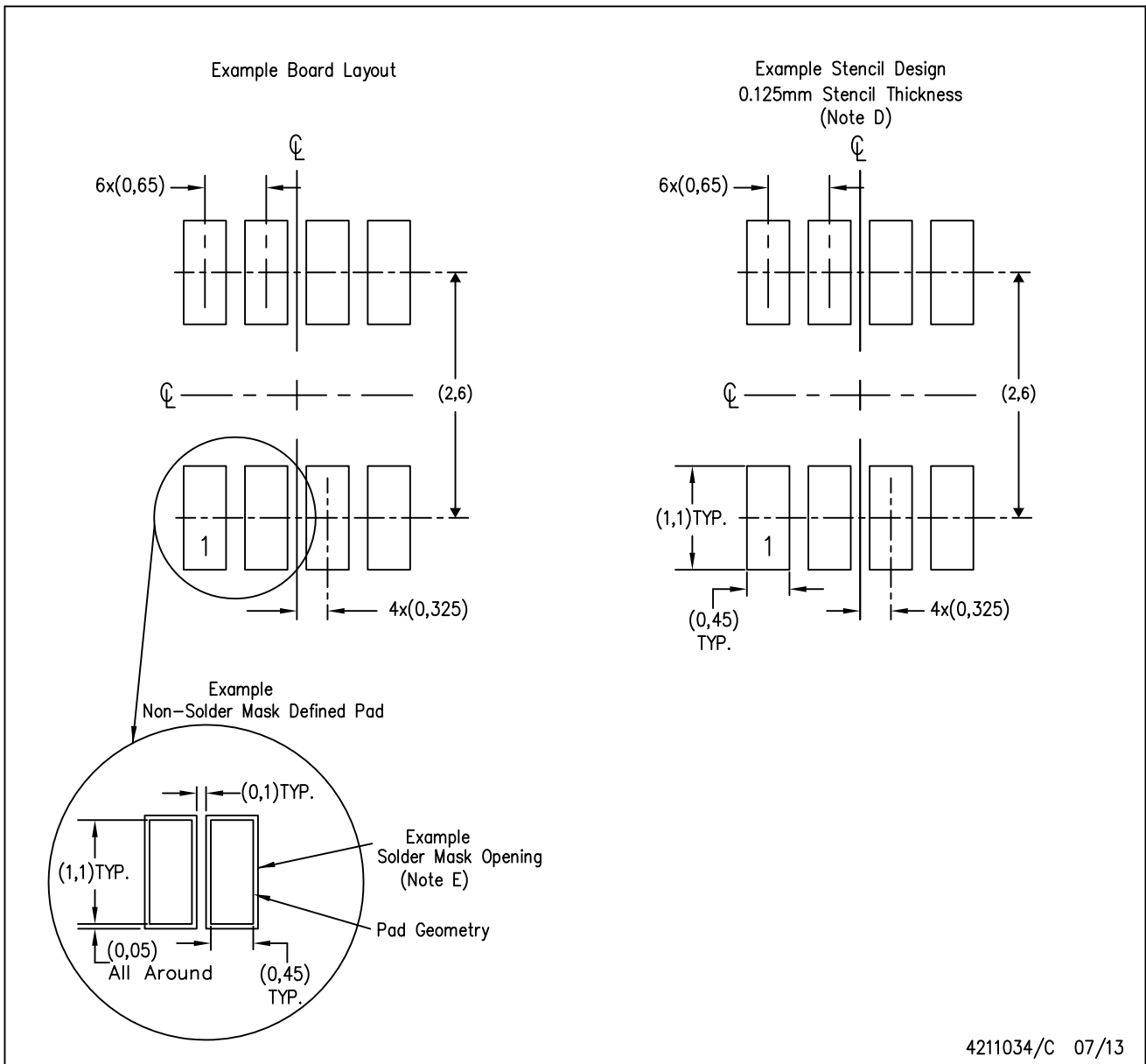

- NOTES:
- A. All linear dimensions are in millimeters.
 - B. This drawing is subject to change without notice.
 - C. Publication IPC-7351 is recommended for alternate designs.
 - D. Laser cutting apertures with trapezoidal walls and also rounding corners will offer better paste release. Customers should contact their board assembly site for stencil design recommendations. Refer to IPC-7525.
 - E. Customers should contact their board fabrication site for solder mask tolerances between and around signal pads.

IMPORTANT NOTICE AND DISCLAIMER

TI PROVIDES TECHNICAL AND RELIABILITY DATA (INCLUDING DATASHEETS), DESIGN RESOURCES (INCLUDING REFERENCE DESIGNS), APPLICATION OR OTHER DESIGN ADVICE, WEB TOOLS, SAFETY INFORMATION, AND OTHER RESOURCES "AS IS" AND WITH ALL FAULTS, AND DISCLAIMS ALL WARRANTIES, EXPRESS AND IMPLIED, INCLUDING WITHOUT LIMITATION ANY IMPLIED WARRANTIES OF MERCHANTABILITY, FITNESS FOR A PARTICULAR PURPOSE OR NON-INFRINGEMENT OF THIRD PARTY INTELLECTUAL PROPERTY RIGHTS.

These resources are intended for skilled developers designing with TI products. You are solely responsible for (1) selecting the appropriate TI products for your application, (2) designing, validating and testing your application, and (3) ensuring your application meets applicable standards, and any other safety, security, or other requirements. These resources are subject to change without notice. TI grants you permission to use these resources only for development of an application that uses the TI products described in the resource. Other reproduction and display of these resources is prohibited. No license is granted to any other TI intellectual property right or to any third party intellectual property right. TI disclaims responsibility for, and you will fully indemnify TI and its representatives against, any claims, damages, costs, losses, and liabilities arising out of your use of these resources.

TI's products are provided subject to TI's Terms of Sale (<https://www.ti.com/legal/termsofsale.html>) or other applicable terms available either on [ti.com](https://www.ti.com) or provided in conjunction with such TI products. TI's provision of these resources does not expand or otherwise alter TI's applicable warranties or warranty disclaimers for TI products.

Mailing Address: Texas Instruments, Post Office Box 655303, Dallas, Texas 75265
Copyright © 2021, Texas Instruments Incorporated