

SN54ABT652A, SN74ABT652A OCTAL REGISTERED TRANSCEIVERS WITH 3-STATE OUTPUTS

SCBS072F – JANUARY 1991 – REVISED MAY 1997

- State-of-the-Art *EPIC-II^B*™ BiCMOS Design Significantly Reduces Power Dissipation
- ESD Protection Exceeds 2000 V Per MIL-STD-883, Method 3015; Exceeds 200 V Using Machine Model (C = 200 pF, R = 0)
- Latch-Up Performance Exceeds 500 mA Per JEDEC Standard JESD-17
- Typical V_{OLP} (Output Ground Bounce) < 1 V at $V_{CC} = 5$ V, $T_A = 25^\circ\text{C}$
- High-Drive Outputs (–32-mA I_{OH} , 64-mA I_{OL})
- Package Options Include Plastic Small-Outline (DW), Shrink Small-Outline (DB), and Thin Shrink Small-Outline (PW) Packages, Ceramic Chip Carriers (FK), Ceramic Flat (W) Package, and Plastic (NT) and Ceramic (JT) DIPs

description

These devices consist of bus-transceiver circuits, D-type flip-flops, and control circuitry arranged for multiplexed transmission of data directly from the data bus or from the internal storage registers.

Output-enable (OEAB and \overline{OEBA}) inputs are provided to control the transceiver functions. Select-control (SAB and SBA) inputs are provided to select either real-time or stored data for transfer. The circuitry used for select control eliminates the typical decoding glitch that occurs in a multiplexer during the transition between stored and real-time data. A low input selects real-time data, and a high input selects stored data. Figure 1 illustrates the four fundamental bus-management functions that can be performed with the 'ABT652A.

Data on the A- or B-data bus, or both, can be stored in the internal D-type flip-flops by low-to-high transitions at the appropriate clock (CLKAB or CLKBA) inputs, regardless of the select- or enable-control inputs. When SAB and SBA are in the real-time transfer mode, it is possible to store data without using the internal D-type flip-flops by simultaneously enabling OEAB and \overline{OEBA} . In this configuration, each output reinforces its input. When all other data sources to the two sets of bus lines are at high impedance, each set of bus lines remains at its last state.

To ensure the high-impedance state during power up or power down, \overline{OEBA} should be tied to V_{CC} through a pullup resistor; the minimum value of the resistor is determined by the current-sinking capability of the driver (B to A). OEAB should be tied to GND through a pulldown resistor; the minimum value of the resistor is determined by the current-sourcing capability of the driver (A to B).

SN54ABT652A . . . JT OR W PACKAGE
SN74ABT652A . . . DB, DW, NT, OR PW PACKAGE
(TOP VIEW)

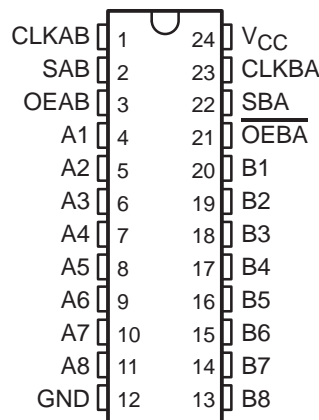

SN54ABT652A . . . FK PACKAGE
(TOP VIEW)

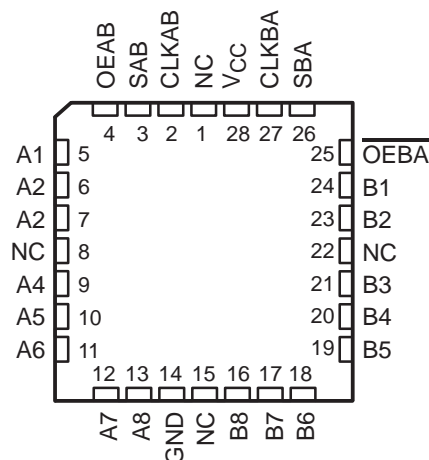

NC – No internal connection



Please be aware that an important notice concerning availability, standard warranty, and use in critical applications of Texas Instruments semiconductor products and disclaimers thereto appears at the end of this data sheet.

EPIC-II^B is a trademark of Texas Instruments Incorporated.

PRODUCTION DATA information is current as of publication date. Products conform to specifications per the terms of Texas Instruments standard warranty. Production processing does not necessarily include testing of all parameters.

TEXAS
INSTRUMENTS

POST OFFICE BOX 655303 • DALLAS, TEXAS 75265

Copyright © 1997, Texas Instruments Incorporated

SN54ABT652A, SN74ABT652A OCTAL REGISTERED TRANSCEIVERS WITH 3-STATE OUTPUTS

SCBS072F – JANUARY 1991 – REVISED MAY 1997

description (continued)

The SN54ABT652A is characterized for operation over the full military temperature range of -55°C to 125°C .
The SN74ABT652A is characterized for operation from -40°C to 85°C .

FUNCTION TABLE

INPUTS						DATA I/O†		OPERATION OR FUNCTION
OEAB	$\overline{\text{OEBA}}$	CLKAB	CLKBA	SAB	SBA	A1–A8	B1–B8	
L	H	H or L	H or L	X	X	Input	Input	Isolation
L	H	↑	↑	X	X	Input	Input	Store A and B data
X	H	↑	H or L	X	X	Input	Unspecified‡	Store A, hold B
H	H	↑	↑	X‡	X	Input	Output	Store A in both registers
L	X	H or L	↑	X	X	Unspecified‡	Input	Hold A, store B
L	L	↑	↑	X	X‡	Output	Input	Store B in both registers
L	L	X	X	X	L	Output	Input	Real-time B data to A bus
L	L	X	H or L	X	H	Output	Input	Stored B data to A bus
H	H	X	X	L	X	Input	Output	Real-time A data to B bus
H	H	H or L	X	H	X	Input	Output	Stored A data to B bus
H	L	H or L	H or L	H	H	Output	Output	Stored A data to B bus and stored B data to A bus

† The data-output functions may be enabled or disabled by a variety of level combinations at OEAB or $\overline{\text{OEBA}}$. Data-input functions are always enabled; i.e., data at the bus terminals is stored on every low-to-high transition of the clock inputs.

‡ Select control = L; clocks can occur simultaneously.

Select control = H; clocks must be staggered to load both registers.

SN54ABT652A, SN74ABT652A OCTAL REGISTERED TRANSCEIVERS WITH 3-STATE OUTPUTS

SCBS072F – JANUARY 1991 – REVISED MAY 1997

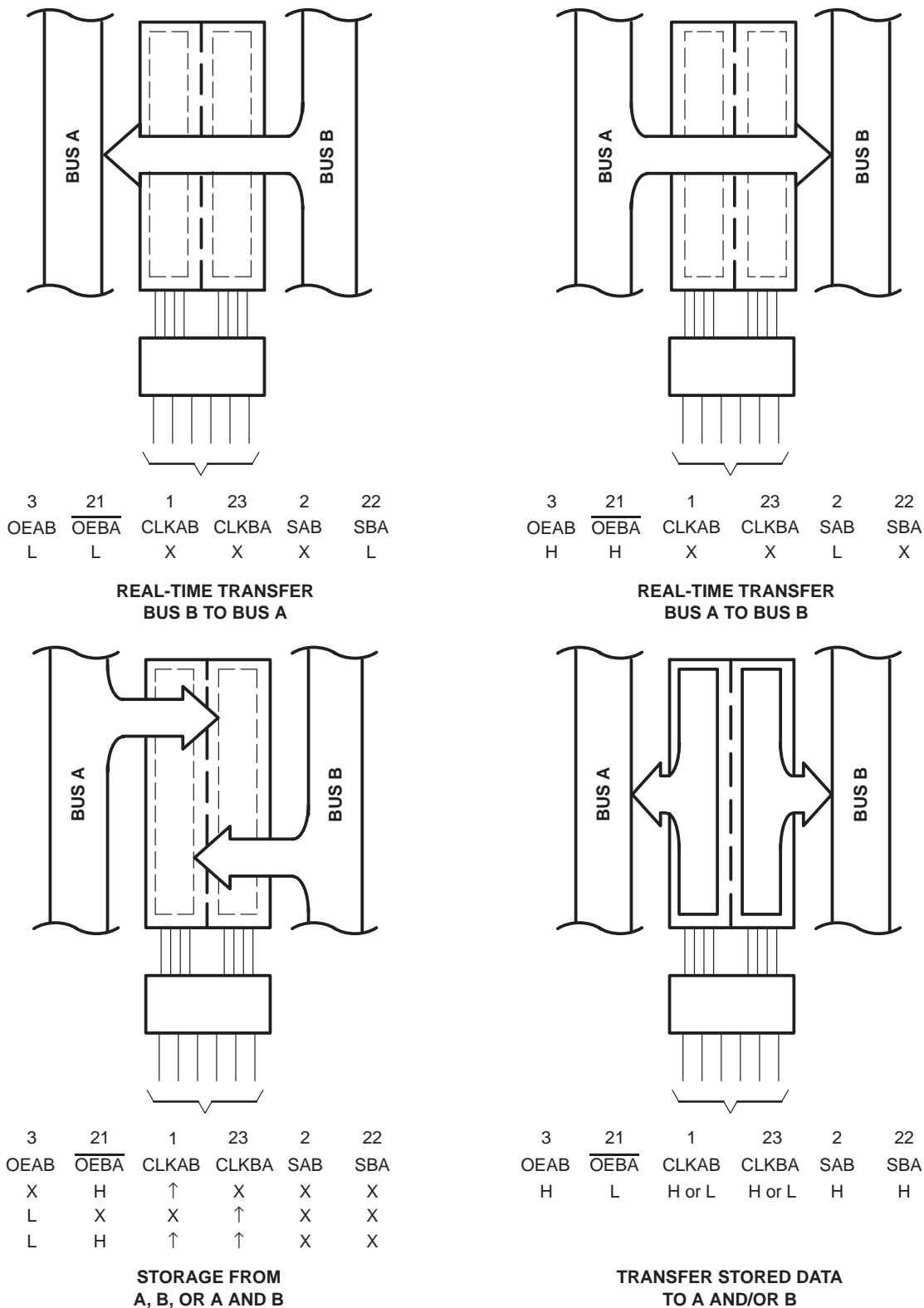

Pin numbers shown are for the DB, DW, JT, NT, PW, and W packages.

Figure 1. Bus-Management Functions

SN54ABT652A, SN74ABT652A OCTAL REGISTERED TRANSCEIVERS WITH 3-STATE OUTPUTS

SCBS072F – JANUARY 1991 – REVISED MAY 1997

logic symbol†

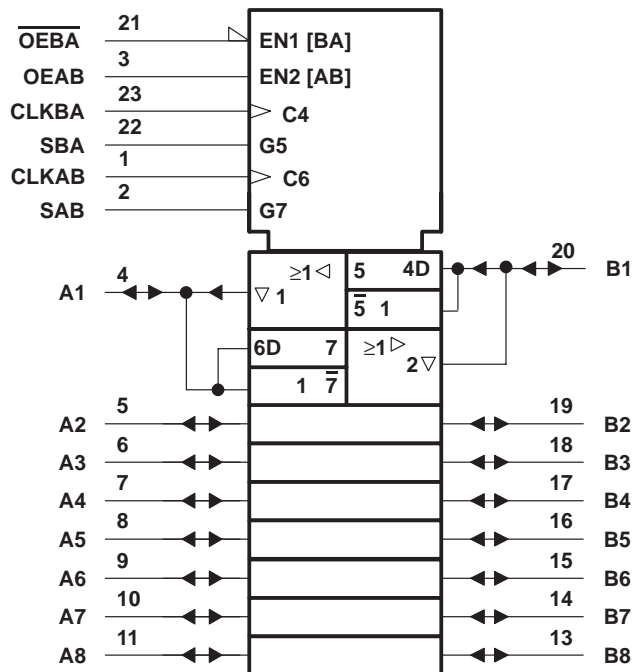

† This symbol is in accordance with ANSI/IEEE Std 91-1984 and IEC Publication 617-12. Pin numbers shown are for the DB, DW, JT, NT, PW, and W packages.

SN54ABT652A, SN74ABT652A
 OCTAL REGISTERED TRANSCEIVERS
 WITH 3-STATE OUTPUTS

SCBS072F - JANUARY 1991 - REVISED MAY 1997

logic diagram (positive logic)

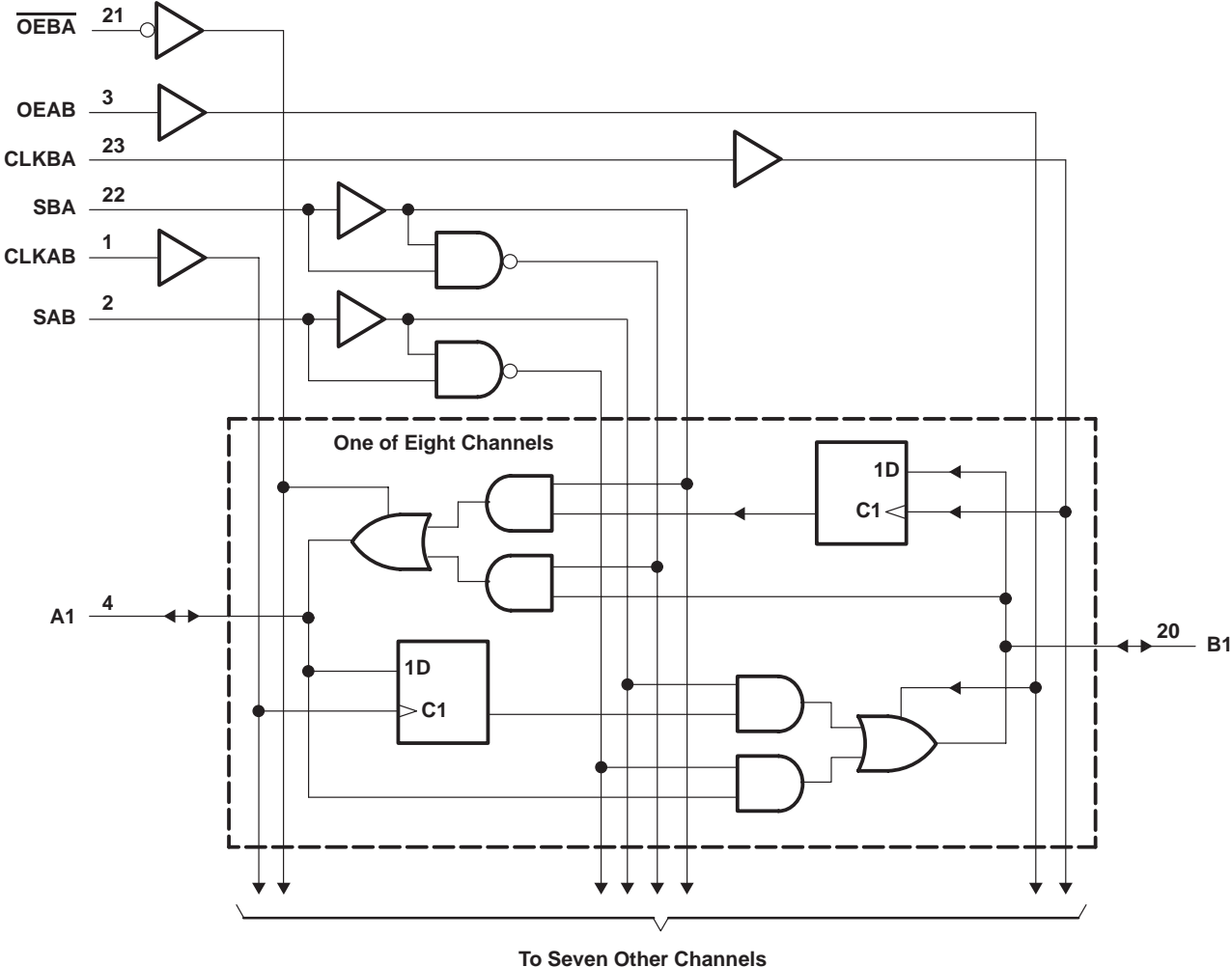

Pin numbers shown are for the DB, DW, JT, NT, PW, and W packages.



SN54ABT652A, SN74ABT652A OCTAL REGISTERED TRANSCEIVERS WITH 3-STATE OUTPUTS

SCBS072F – JANUARY 1991 – REVISED MAY 1997

absolute maximum ratings over operating free-air temperature range (unless otherwise noted)†

Supply voltage range, V_{CC}	-0.5 V to 7 V
Input voltage range, V_I (except I/O ports) (see Note 1)	-0.5 V to 7 V
Voltage range applied to any output in the high or power-off state, V_O	-0.5 V to 5.5 V
Current into any output in the low state, I_O : SN54ABT652A	96 mA
SN74ABT652A	128 mA
Input clamp current, I_{IK} ($V_I < 0$)	-18 mA
Output clamp current, I_{OK} ($V_O < 0$)	-50 mA
Package thermal impedance, θ_{JA} (see Note 2): DB package	104°C/W
DW package	81°C/W
NT package	67°C/W
PW package	120°C/W
Storage temperature range, T_{stg}	-65°C to 150°C

† Stresses beyond those listed under “absolute maximum ratings” may cause permanent damage to the device. These are stress ratings only, and functional operation of the device at these or any other conditions beyond those indicated under “recommended operating conditions” is not implied. Exposure to absolute-maximum-rated conditions for extended periods may affect device reliability.

- NOTES: 1. The input and output negative-voltage ratings may be exceeded if the input and output clamp-current ratings are observed.
2. The package thermal impedance is calculated in accordance with EIA/JEDEC Std JESD51, except for through-hole packages, which use a trace length of zero.

recommended operating conditions (see Note 3)

		SN54ABT652A		SN74ABT652A		UNIT
		MIN	MAX	MIN	MAX	
V_{CC}	Supply voltage	4.5	5.5	4.5	5.5	V
V_{IH}	High-level input voltage	2		2		V
V_{IL}	Low-level input voltage		0.8		0.8	V
V_I	Input voltage	0	V_{CC}	0	V_{CC}	V
I_{OH}	High-level output current		-24		-32	mA
I_{OL}	Low-level output current		48		64	mA
$\Delta t/\Delta v$	Input transition rise or fall rate		5		5	ns/V
	Outputs enabled					
T_A	Operating free-air temperature	-55	125	-40	85	°C

NOTE 3: Unused pins (input or I/O) must be held high or low to prevent them from floating.



SN54ABT652A, SN74ABT652A
OCTAL REGISTERED TRANSCEIVERS
WITH 3-STATE OUTPUTS

SCBS072F – JANUARY 1991 – REVISED MAY 1997

electrical characteristics over recommended operating free-air temperature range (unless otherwise noted)

PARAMETER	TEST CONDITIONS	T _A = 25°C			SN54ABT652A		SN74ABT652A		UNIT	
		MIN	TYP†	MAX	MIN	MAX	MIN	MAX		
V _{IK}	V _{CC} = 4.5 V, I _I = -18 mA			-1.2		-1.2		-1.2	V	
V _{OH}	V _{CC} = 4.5 V, I _{OH} = -3 mA			2.5		2.5		2.5	V	
	V _{CC} = 5 V, I _{OH} = -3 mA			3		3		3		
	V _{CC} = 4.5 V	I _{OH} = -24 mA			2		2			
I _{OH} = -32 mA				2*				2		
V _{OL}	V _{CC} = 4.5 V	I _{OL} = 48 mA				0.55			V	
		I _{OL} = 64 mA				0.55*		0.55		
V _{hys}				100					mV	
I _I	Control inputs	V _{CC} = 5.5 V, V _I = V _{CC} or GND			±1		±1		±1	μA
	A or B ports				±100		±100		±100	
I _{OZH} ‡	V _{CC} = 5.5 V, V _O = 2.7 V			50**		10		50	μA	
I _{OZL} ‡	V _{CC} = 5.5 V, V _O = 0.5 V			-50**		-10		-50	μA	
I _{off}	V _{CC} = 0, V _I or V _O ≤ 4.5 V			±100				±100	μA	
I _{CEX}	V _{CC} = 5.5 V, V _O = 5.5 V	Outputs high			50	50		50	μA	
I _O §	V _{CC} = 5.5 V, V _O = 2.5 V			-50	-100	-180		-50	-180	mA
I _{CC}	V _{CC} = 5.5 V, I _O = 0, V _I = V _{CC} or GND	Outputs high			250	250		250	μA	
		Outputs low			30	30		30	mA	
		Outputs disabled			250	250		250	μA	
ΔI _{CC} ¶	V _{CC} = 5.5 V, One input at 3.4 V, Other inputs at V _{CC} or GND				1.5	1.5		1.5	mA	
C _i	Control inputs	V _I = 2.5 V or 0.5 V			7				pF	
C _{io}	A or B ports	V _O = 2.5 V or 0.5 V			12				pF	

* On products compliant to MIL-PRF-38535, this parameter does not apply.

** These limits apply only to the SN74ABT652A.

† All typical values are at V_{CC} = 5 V.

‡ The parameters I_{OZH} and I_{OZL} include the input leakage current.

§ Not more than one output should be tested at a time, and the duration of the test should not exceed one second.

¶ This is the increase in supply current for each input that is at the specified TTL voltage level rather than V_{CC} or GND.



SN54ABT652A, SN74ABT652A
OCTAL REGISTERED TRANSCEIVERS
WITH 3-STATE OUTPUTS

SCBS072F – JANUARY 1991 – REVISED MAY 1997

timing requirements over recommended ranges of supply voltage and operating free-air temperature (unless otherwise noted) (see Figure 2)

	SN54ABT652A				UNIT
	V _{CC} = 5 V, T _A = 25°C		MIN	MAX	
	MIN	MAX			
f _{clock} Clock frequency	0	125	0	125	MHz
t _w Pulse duration, CLK high or low	4		4		ns
t _{su} Setup time, A or B before CLKAB↑ or CLKBA↑	3		3.5		ns
t _h Hold time, A or B after CLKAB↑ or CLKBA↑	1.5		1.5		ns

timing requirements over recommended ranges of supply voltage and operating free-air temperature (unless otherwise noted) (see Figure 2)

	SN74ABT652A				UNIT
	V _{CC} = 5 V, T _A = 25°C		MIN	MAX	
	MIN	MAX			
f _{clock} Clock frequency	0	125	0	125	MHz
t _w Pulse duration, CLK high or low	4		4		ns
t _{su} Setup time, A or B before CLKAB↑ or CLKBA↑	3		3		ns
t _h Hold time, A or B after CLKAB↑ or CLKBA↑	0		0		ns



SN54ABT652A, SN74ABT652A
OCTAL REGISTERED TRANSCEIVERS
WITH 3-STATE OUTPUTS

SCBS072F – JANUARY 1991 – REVISED MAY 1997

switching characteristics over recommended ranges of supply voltage and operating free-air temperature, $C_L = 50$ pF (unless otherwise noted) (see Figure 2)

PARAMETER	FROM (INPUT)	TO (OUTPUT)	SN54ABT652A					UNIT
			$V_{CC} = 5$ V, $T_A = 25^\circ$ C			MIN	MAX	
			MIN	TYP	MAX			
f_{max}			125	200		125	MHz	
t_{PLH}	CLK	B or A	2.2	4	5.1	1.7	5.9	ns
t_{PHL}			1.7	4	5.1	1.7	5.9	
t_{PLH}	A or B	B or A	1.5	3	4.8	1	5	ns
t_{PHL}			1.5	3.3	4.6	1	5.6	
t_{PLH}	SAB or SBA†	B or A	1.5	4	5.5	1.5	6.8	ns
t_{PHL}			1.5	3.6	4.9	1.5	6.2	
t_{PZH}	\overline{OEBA}	A	2	3.6	5.4	2	6.8	ns
t_{PZL}			3	5.7	7.7	3	9.2	
t_{PHZ}	\overline{OEBA}	A	1.5	3.2	5.8	1	7.5	ns
t_{PLZ}			1.5	3	4.3	1	4.6	
t_{PZH}	OEAB	B	2	4.3	6.1	2	7.8	ns
t_{PZL}			3	5.5	7.4	3	8.9	
t_{PHZ}	OEAB	B	1.5	3.3	6	1	8	ns
t_{PLZ}			1.5	3.4	5	1.5	6.8	

† These parameters are measured with the internal output state of the storage register opposite that of the bus input.

switching characteristics over recommended ranges of supply voltage and operating free-air temperature, $C_L = 50$ pF (unless otherwise noted) (see Figure 2)

PARAMETER	FROM (INPUT)	TO (OUTPUT)	SN74ABT652A					UNIT
			$V_{CC} = 5$ V, $T_A = 25^\circ$ C			MIN	MAX	
			MIN	TYP	MAX			
f_{max}			125	200		125	MHz	
t_{PLH}	CLK	B or A	2.2	4	5.1	2.2	5.6	ns
t_{PHL}			1.7	4	5.1	1.7	5.6	
t_{PLH}	A or B	B or A	1.5	3	4.3	1.5	4.8	ns
t_{PHL}			1.5	3.3	4.6	1.5	5.4	
t_{PLH}	SAB or SBA†	B or A	1.5	4	5.1	1.5	6.5	ns
t_{PHL}			1.5	3.6	4.9	1.5	5.9	
t_{PZH}	\overline{OEBA}	A	2	3.6	4.6	2	5.8	ns
t_{PZL}			3	5.7	6.8	3	8.5	
t_{PHZ}	\overline{OEBA}	A	1.5	3.2	4.5	1.5	5	ns
t_{PLZ}			1.5	3	3.8	1.5	4.1	
t_{PZH}	OEAB	B	2	4.3	6.1	2	6.5	ns
t_{PZL}			3	5.5	6.5	3	7.4	
t_{PHZ}	OEAB	B	1.5	3.3	4.5	1.5	5.5	ns
t_{PLZ}			1.5	3.4	4.4	1.5	5.1	

† These parameters are measured with the internal output state of the storage register opposite that of the bus input.



SN54ABT652A, SN74ABT652A
OCTAL REGISTERED TRANSCEIVERS
WITH 3-STATE OUTPUTS

SCBS072F – JANUARY 1991 – REVISED MAY 1997

PARAMETER MEASUREMENT INFORMATION

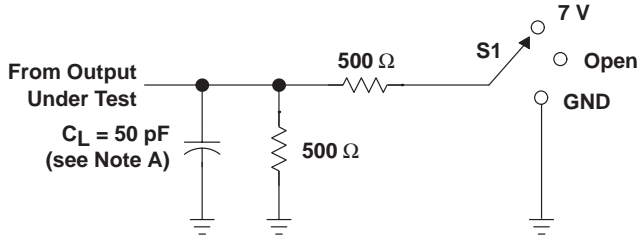

TEST	S1
t_{PLH}/t_{PHL}	Open
t_{PLZ}/t_{PZL}	7 V
t_{PHZ}/t_{PZH}	Open

LOAD CIRCUIT

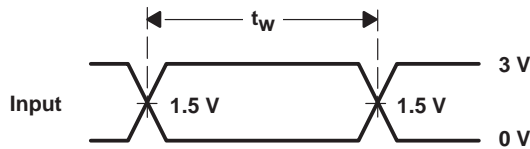

VOLTAGE WAVEFORMS
PULSE DURATION

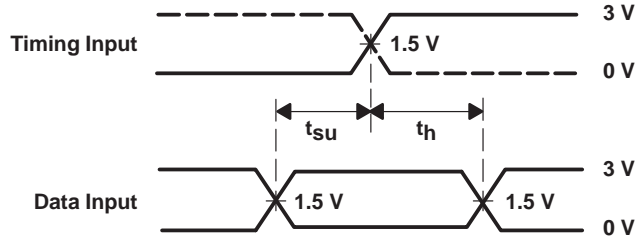

VOLTAGE WAVEFORMS
SETUP AND HOLD TIMES

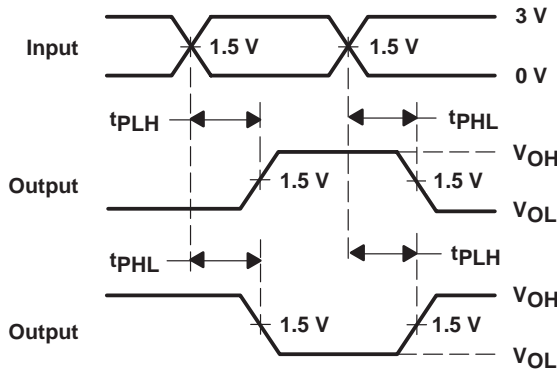

VOLTAGE WAVEFORMS
PROPAGATION DELAY TIMES
INVERTING AND NONINVERTING OUTPUTS

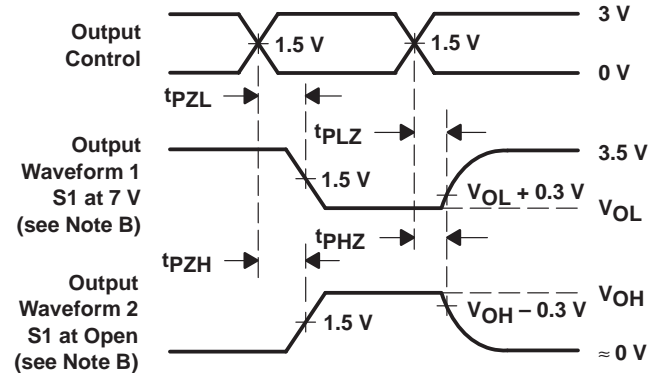

VOLTAGE WAVEFORMS
ENABLE AND DISABLE TIMES
LOW- AND HIGH-LEVEL ENABLING

- NOTES: A. C_L includes probe and jig capacitance.
 B. Waveform 1 is for an output with internal conditions such that the output is low except when disabled by the output control. Waveform 2 is for an output with internal conditions such that the output is high except when disabled by the output control.
 C. All input pulses are supplied by generators having the following characteristics: $PRR \leq 10$ MHz, $Z_O = 50 \Omega$, $t_r \leq 2.5$ ns, $t_f \leq 2.5$ ns.
 D. The outputs are measured one at a time with one transition per measurement.

Figure 2. Load Circuit and Voltage Waveforms

PACKAGING INFORMATION

Orderable Device	Status (1)	Package Type	Package Drawing	Pins	Package Qty	Eco Plan (2)	Lead finish/ Ball material (6)	MSL Peak Temp (3)	Op Temp (°C)	Device Marking (4/5)	Samples
5962-9324202Q3A	ACTIVE	LCCC	FK	28	1	Non-RoHS & Green	SNPB	N / A for Pkg Type	-55 to 125	5962-9324202Q3A SNJ54ABT 652AFK	Samples
SN74ABT652ADBR	ACTIVE	SSOP	DB	24	2000	RoHS & Green	NIPDAU	Level-1-260C-UNLIM	-40 to 85	AB652A	Samples
SN74ABT652ADBRE4	ACTIVE	SSOP	DB	24	2000	RoHS & Green	NIPDAU	Level-1-260C-UNLIM	-40 to 85	AB652A	Samples
SN74ABT652ADW	ACTIVE	SOIC	DW	24	25	RoHS & Green	NIPDAU	Level-1-260C-UNLIM	-40 to 85	ABT652A	Samples
SN74ABT652ADWR	ACTIVE	SOIC	DW	24	2000	RoHS & Green	NIPDAU	Level-1-260C-UNLIM	-40 to 85	ABT652A	Samples
SNJ54ABT652AFK	ACTIVE	LCCC	FK	28	1	Non-RoHS & Green	SNPB	N / A for Pkg Type	-55 to 125	5962-9324202Q3A SNJ54ABT 652AFK	Samples

(1) The marketing status values are defined as follows:

ACTIVE: Product device recommended for new designs.

LIFEBUY: TI has announced that the device will be discontinued, and a lifetime-buy period is in effect.

NRND: Not recommended for new designs. Device is in production to support existing customers, but TI does not recommend using this part in a new design.

PREVIEW: Device has been announced but is not in production. Samples may or may not be available.

OBSOLETE: TI has discontinued the production of the device.

(2) **RoHS:** TI defines "RoHS" to mean semiconductor products that are compliant with the current EU RoHS requirements for all 10 RoHS substances, including the requirement that RoHS substance do not exceed 0.1% by weight in homogeneous materials. Where designed to be soldered at high temperatures, "RoHS" products are suitable for use in specified lead-free processes. TI may reference these types of products as "Pb-Free".

RoHS Exempt: TI defines "RoHS Exempt" to mean products that contain lead but are compliant with EU RoHS pursuant to a specific EU RoHS exemption.

Green: TI defines "Green" to mean the content of Chlorine (Cl) and Bromine (Br) based flame retardants meet JS709B low halogen requirements of <=1000ppm threshold. Antimony trioxide based flame retardants must also meet the <=1000ppm threshold requirement.

(3) MSL, Peak Temp. - The Moisture Sensitivity Level rating according to the JEDEC industry standard classifications, and peak solder temperature.

(4) There may be additional marking, which relates to the logo, the lot trace code information, or the environmental category on the device.

⁽⁵⁾ Multiple Device Markings will be inside parentheses. Only one Device Marking contained in parentheses and separated by a "-" will appear on a device. If a line is indented then it is a continuation of the previous line and the two combined represent the entire Device Marking for that device.

⁽⁶⁾ Lead finish/Ball material - Orderable Devices may have multiple material finish options. Finish options are separated by a vertical ruled line. Lead finish/Ball material values may wrap to two lines if the finish value exceeds the maximum column width.

Important Information and Disclaimer:The information provided on this page represents TI's knowledge and belief as of the date that it is provided. TI bases its knowledge and belief on information provided by third parties, and makes no representation or warranty as to the accuracy of such information. Efforts are underway to better integrate information from third parties. TI has taken and continues to take reasonable steps to provide representative and accurate information but may not have conducted destructive testing or chemical analysis on incoming materials and chemicals. TI and TI suppliers consider certain information to be proprietary, and thus CAS numbers and other limited information may not be available for release.

In no event shall TI's liability arising out of such information exceed the total purchase price of the TI part(s) at issue in this document sold by TI to Customer on an annual basis.

OTHER QUALIFIED VERSIONS OF SN54ABT652A, SN74ABT652A :

- Catalog: [SN74ABT652A](#)
- Military: [SN54ABT652A](#)

NOTE: Qualified Version Definitions:

- Catalog - TI's standard catalog product
- Military - QML certified for Military and Defense Applications

TAPE AND REEL INFORMATION

QUADRANT ASSIGNMENTS FOR PIN 1 ORIENTATION IN TAPE

*All dimensions are nominal

Device	Package Type	Package Drawing	Pins	SPQ	Reel Diameter (mm)	Reel Width W1 (mm)	A0 (mm)	B0 (mm)	K0 (mm)	P1 (mm)	W (mm)	Pin1 Quadrant
SN74ABT652ADBR	SSOP	DB	24	2000	330.0	16.4	8.2	8.8	2.5	12.0	16.0	Q1
SN74ABT652ADWR	SOIC	DW	24	2000	330.0	24.4	10.75	15.7	2.7	12.0	24.0	Q1

TAPE AND REEL BOX DIMENSIONS

*All dimensions are nominal

Device	Package Type	Package Drawing	Pins	SPQ	Length (mm)	Width (mm)	Height (mm)
SN74ABT652ADBR	SSOP	DB	24	2000	853.0	449.0	35.0
SN74ABT652ADWR	SOIC	DW	24	2000	350.0	350.0	43.0

TUBE

*All dimensions are nominal

Device	Package Name	Package Type	Pins	SPQ	L (mm)	W (mm)	T (μm)	B (mm)
SN74ABT652ADW	DW	SOIC	24	25	506.98	12.7	4826	6.6

DW (R-PDSO-G24)

PLASTIC SMALL OUTLINE



- NOTES:
- A. All linear dimensions are in inches (millimeters). Dimensioning and tolerancing per ASME Y14.5M-1994.
 - B. This drawing is subject to change without notice.
 - C. Body dimensions do not include mold flash or protrusion not to exceed 0.006 (0,15).
 - D. Falls within JEDEC MS-013 variation AD.

DB (R-PDSO-G**)

PLASTIC SMALL-OUTLINE

28 PINS SHOWN



- NOTES: A. All linear dimensions are in millimeters.
 B. This drawing is subject to change without notice.
 C. Body dimensions do not include mold flash or protrusion not to exceed 0,15.
 D. Falls within JEDEC MO-150

FK (S-CQCC-N**)

LEADLESS CERAMIC CHIP CARRIER

28 TERMINAL SHOWN



NO. OF TERMINALS **	A		B	
	MIN	MAX	MIN	MAX
20	0.342 (8,69)	0.358 (9,09)	0.307 (7,80)	0.358 (9,09)
28	0.442 (11,23)	0.458 (11,63)	0.406 (10,31)	0.458 (11,63)
44	0.640 (16,26)	0.660 (16,76)	0.495 (12,58)	0.560 (14,22)
52	0.740 (18,78)	0.761 (19,32)	0.495 (12,58)	0.560 (14,22)
68	0.938 (23,83)	0.962 (24,43)	0.850 (21,6)	0.858 (21,8)
84	1.141 (28,99)	1.165 (29,59)	1.047 (26,6)	1.063 (27,0)



4040140/D 01/11

- NOTES:
- All linear dimensions are in inches (millimeters).
 - This drawing is subject to change without notice.
 - This package can be hermetically sealed with a metal lid.
 - Falls within JEDEC MS-004

IMPORTANT NOTICE AND DISCLAIMER

TI PROVIDES TECHNICAL AND RELIABILITY DATA (INCLUDING DATA SHEETS), DESIGN RESOURCES (INCLUDING REFERENCE DESIGNS), APPLICATION OR OTHER DESIGN ADVICE, WEB TOOLS, SAFETY INFORMATION, AND OTHER RESOURCES "AS IS" AND WITH ALL FAULTS, AND DISCLAIMS ALL WARRANTIES, EXPRESS AND IMPLIED, INCLUDING WITHOUT LIMITATION ANY IMPLIED WARRANTIES OF MERCHANTABILITY, FITNESS FOR A PARTICULAR PURPOSE OR NON-INFRINGEMENT OF THIRD PARTY INTELLECTUAL PROPERTY RIGHTS.

These resources are intended for skilled developers designing with TI products. You are solely responsible for (1) selecting the appropriate TI products for your application, (2) designing, validating and testing your application, and (3) ensuring your application meets applicable standards, and any other safety, security, regulatory or other requirements.

These resources are subject to change without notice. TI grants you permission to use these resources only for development of an application that uses the TI products described in the resource. Other reproduction and display of these resources is prohibited. No license is granted to any other TI intellectual property right or to any third party intellectual property right. TI disclaims responsibility for, and you will fully indemnify TI and its representatives against, any claims, damages, costs, losses, and liabilities arising out of your use of these resources.

TI's products are provided subject to [TI's Terms of Sale](#) or other applicable terms available either on ti.com or provided in conjunction with such TI products. TI's provision of these resources does not expand or otherwise alter TI's applicable warranties or warranty disclaimers for TI products.

TI objects to and rejects any additional or different terms you may have proposed.

Mailing Address: Texas Instruments, Post Office Box 655303, Dallas, Texas 75265
Copyright © 2022, Texas Instruments Incorporated