

- Single 5-V Supply
- $\pm 100$ -mV Sensitivity
- For Application as:
  - Single-Ended Line Receiver
  - Gated Oscillator
  - Level Comparator
- Adjustable Reference Voltage
- TTL Outputs
- TTL-Compatible Strobe
- Designed for Party-Line (Data-Bus) Applications
- Common Reference-Voltage Pin
- Common Strobe

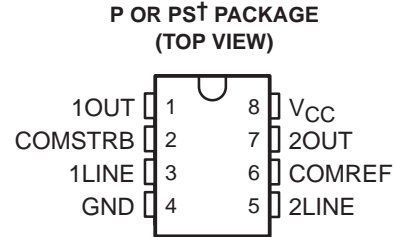

† The PS package is only available left-ended taped and reeled (order SN75140 PSR).

## description

This device consists of a dual single-ended line receiver with TTL-compatible strobes and outputs. The reference voltage (switching threshold) is applied externally and can be adjusted from 1.5 V to 3.5 V, making it possible to optimize noise immunity for a given system design. Due to the low input current (less than 100  $\mu$ A), the device is suited ideally for party-line (data-bus) systems.

The SN75140 has a common reference-voltage pin and a common strobe.

The SN75140 is characterized for operation from 0°C to 70°C.

**FUNCTION TABLE  
(each receiver)**

LINE INPUT	STROBE	OUTPUT
$\leq V_{ref} - 100$ mV	L	H
$\geq V_{ref} + 100$ mV	X	L
X	H	L

H = high level, L = low level, X = irrelevant

## logic symbol†‡

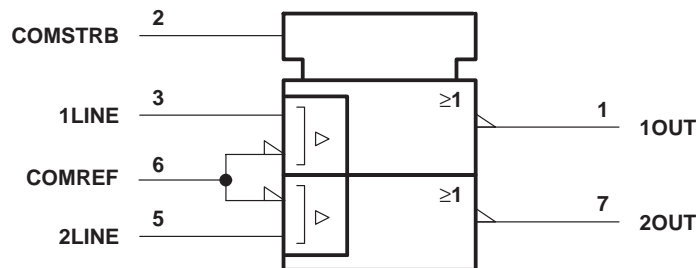

‡ This symbol is in accordance with ANSI/IEEE Std 91-1984 and IEC Publication 617-12.



Please be aware that an important notice concerning availability, standard warranty, and use in critical applications of Texas Instruments semiconductor products and disclaimers thereto appears at the end of this data sheet.

# SN75140 DUAL LINE RECEIVER

SLLS080C – JANUARY 1977 – REVISED APRIL 1998

## logic diagram (positive logic)

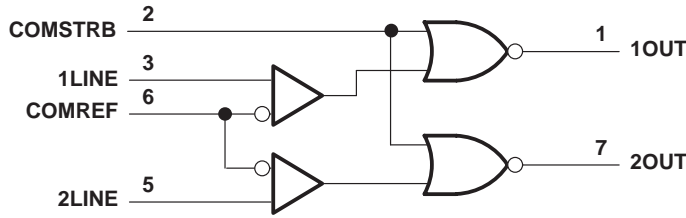

## schematic (each receiver)

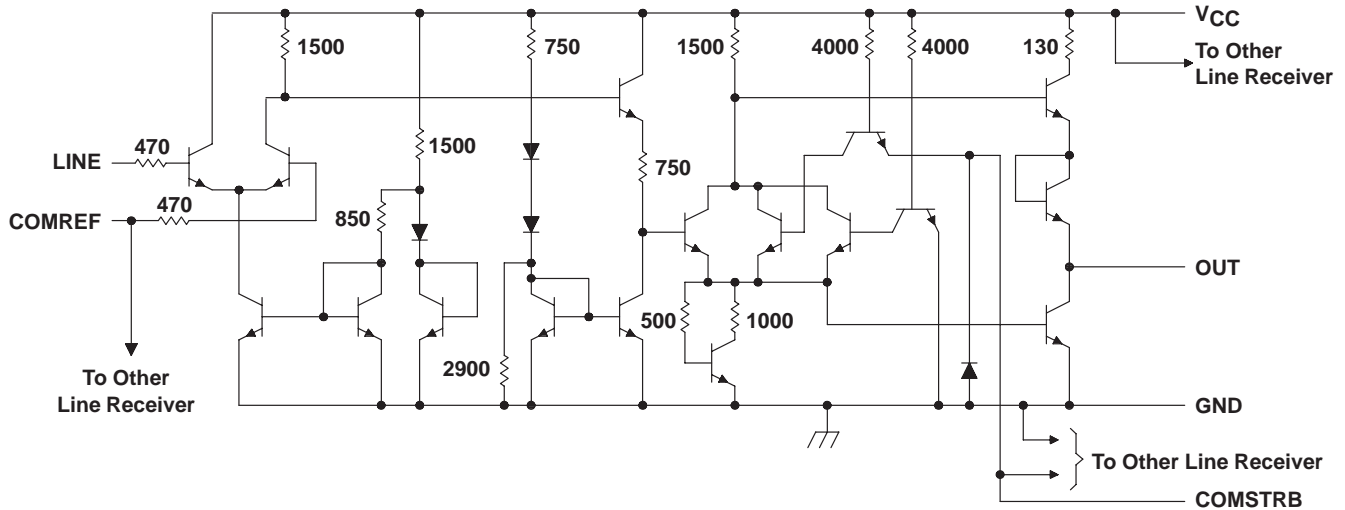

NOTE: Resistor values shown are nominal and in ohms.

## absolute maximum ratings over operating free-air temperature range (unless otherwise noted)†

Supply voltage, $V_{CC}$ (see Note 1)	7 V
Reference input voltage, $V_{ref}$	5.5 V
Line input voltage range with respect to GND	-2 V to 5.5 V
Line input voltage with respect to $V_{ref}$	$\pm 5$ V
Strobe input voltage	5.5 V
Continuous total power dissipation	See Dissipation Rating Table
Storage temperature range, $T_{stg}$	-65°C to 150°C
Lead temperature 1,6 mm (1/16 inch) from case for 10 seconds	260°C

† Stresses beyond those listed under "absolute maximum ratings" may cause permanent damage to the device. These are stress ratings only, and functional operation of the device at these or any other conditions beyond those indicated under "recommended operating conditions" is not implied. Exposure to absolute-maximum-rated conditions for extended periods may affect device reliability.

NOTE 1: Unless otherwise specified, voltage values are with respect to network ground terminal.

DISSIPATION RATING TABLE

PACKAGE	$T_A \leq 25^\circ\text{C}$ POWER RATING	DERATING FACTOR ABOVE $T_A = 25^\circ\text{C}$	$T_A = 70^\circ\text{C}$ POWER RATING
P	1000 mW	8.0 mW/°C	640 mW
PS	450 mW	3.6 mW/°C	288 mW

**recommended operating conditions**

	MIN	NOM	MAX	UNIT
Supply voltage, $V_{CC}$	4.5	5	5.5	V
Reference input voltage, $V_{ref}$	1.5		3.5	V
High-level line input voltage, $V_{IH(L)}$	$V_{ref}+0.1$		$V_{CC}-1$	V
Low-level line input voltage, $V_{IL(L)}$	0		$V_{ref}-0.1$	V
High-level strobe input voltage, $V_{IH(S)}$	2		5.5	V
Low-level strobe input voltage, $V_{IL(S)}$	0		0.8	V
Operating free-air temperature range, $T_A$	0		70	°C

**electrical characteristics over recommended operating free-air temperature range,  $V_{CC} = 5\text{ V} \pm 10\%$ ,  $V_{ref} = 1.5\text{ V}$  to  $3.5\text{ V}$  (unless otherwise noted)**

PARAMETER		TEST CONDITIONS	MIN	TYP†	MAX	UNIT	
$V_{IK}$	Strobe input clamp voltage	$I_{I(S)} = -12\text{ mA}$			-1.5	V	
$V_{OH}$	High-level output voltage	$V_{IL(L)} = V_{ref} - 100\text{ mV}$ , $V_{IL(S)} = 0.8\text{ V}$ , $I_{OH} = -400\text{ }\mu\text{A}$	2.4			V	
$V_{OL}$	Low-level output voltage	$V_{IH(L)} = V_{ref} + 100\text{ mV}$ , $V_{IL(S)} = 0.8\text{ V}$ , $I_{OL} = 16\text{ mA}$			0.4	V	
		$V_{IL(L)} = V_{ref} - 100\text{ mV}$ , $V_{IH(S)} = 2\text{ V}$ , $I_{OL} = 16\text{ mA}$			0.4		
$I_{I(S)}$	Strobe input current at maximum input voltage	Strobe	$V_{I(S)} = 5.5\text{ V}$		1	mA	
		COMSTRB			2		
$I_{IH}$	High-level input current	Strobe	$V_{I(S)} = 2.4\text{ V}$		40	$\mu\text{A}$	
		COMSTRB			80		
		LINE	$V_{I(L)} = 3.5\text{ V}$ ,	$V_{ref} = 1.5\text{ V}$	35		100
		Reference	$V_{I(L)} = 0$ ,	$V_{ref} = 3.5\text{ V}$	35		100
COMREF			70	200			
$I_{IL}$	Low-level input current	Strobe	$V_{I(S)} = 0.4\text{ V}$		-1.6	mA	
		COMSTRB			-3.2		
		LINE	$V_{I(L)} = 0$ ,	$V_{ref} = 1.5\text{ V}$	-10	$\mu\text{A}$	
		Reference	$V_{I(L)} = 1.5\text{ V}$ ,	$V_{ref} = 0$	-10		
COMREF			-20				
$I_{OS}$	Short-circuit output current‡	$V_{CC} = 5.5\text{ V}$	-18		-55	mA	
$I_{CCH}$	Supply current, output high	$V_{I(S)} = 0$ ,		$V_{I(L)} = V_{ref} - 100\text{ mV}$	18	30	mA
$I_{CCL}$	Supply current, output low	$V_{I(S)} = 0$ ,		$V_{I(L)} = V_{ref} + 100\text{ mV}$	20	35	mA

† All typical values are at  $V_{CC} = 5\text{ V}$ ,  $T_A = 25^\circ\text{C}$ .

‡ Only one output should be shorted at a time.

**switching characteristics,  $V_{CC} = 5\text{ V}$ ,  $V_{ref} = 2.5\text{ V}$ ,  $T_A = 25^\circ\text{C}$**

PARAMETER		TEST CONDITIONS	MIN	TYP	MAX	UNIT
$t_{PLH(L)}$	Propagation delay time, low- to high-level output from LINE	$C_L = 15\text{ pF}$ , $R_L = 400\text{ k}\Omega$ , See Figure 1		22	35	ns
$t_{PHL(L)}$	Propagation delay time, high- to low-level output from LINE	$C_L = 15\text{ pF}$ , $R_L = 400\text{ k}\Omega$ , See Figure 1		22	30	ns
$t_{PLH(S)}$	Propagation delay time, low- to high-level output from COMSTRB	$C_L = 15\text{ pF}$ , $R_L = 400\text{ k}\Omega$ , See Figure 1		12	22	ns
$t_{PHL(S)}$	Propagation delay time, high- to low-level output from COMSTRB	$C_L = 15\text{ pF}$ , $R_L = 400\text{ k}\Omega$ , See Figure 1		8	15	ns

# SN75140 DUAL LINE RECEIVER

SLLS080C – JANUARY 1977 – REVISED APRIL 1998

## PARAMETER MEASUREMENT INFORMATION

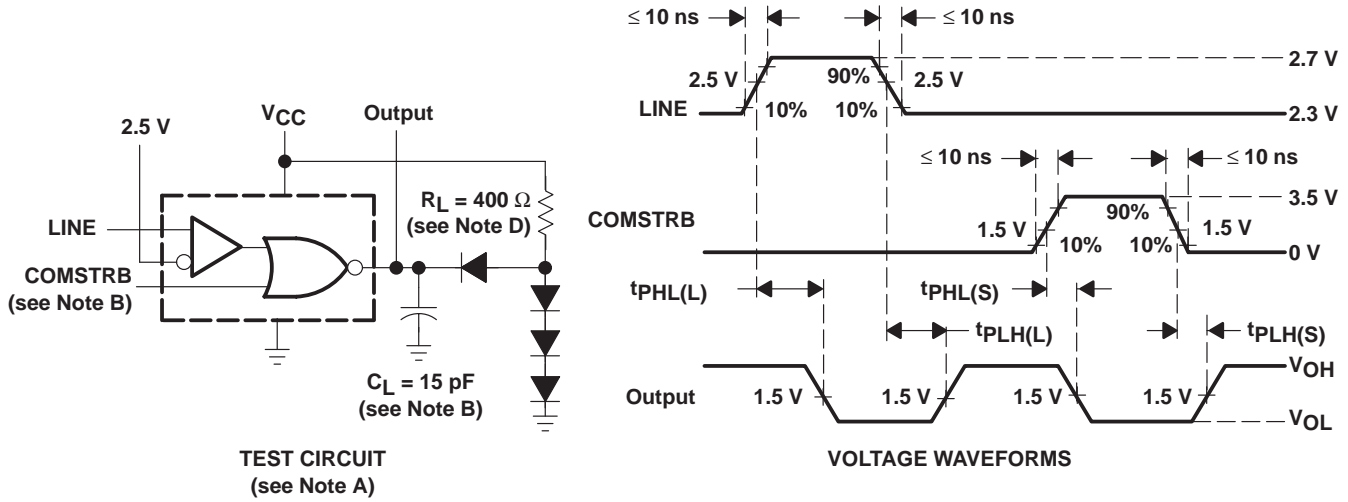

- NOTES: A. Input pulses are supplied by generators having the following characteristics: PRR  $\leq$  1 MHz, duty cycle  $\leq$  50%,  $Z_O = 50 \Omega$ .  
 B. Unused strobes are to be grounded.  
 C.  $C_L$  includes probe and jig capacitance.  
 D. All diodes are 1N3064.

Figure 1. Test Circuit and Voltage Waveforms

## TYPICAL CHARACTERISTICS

OUTPUT VOLTAGE  
vs  
LINE INPUT VOLTAGE

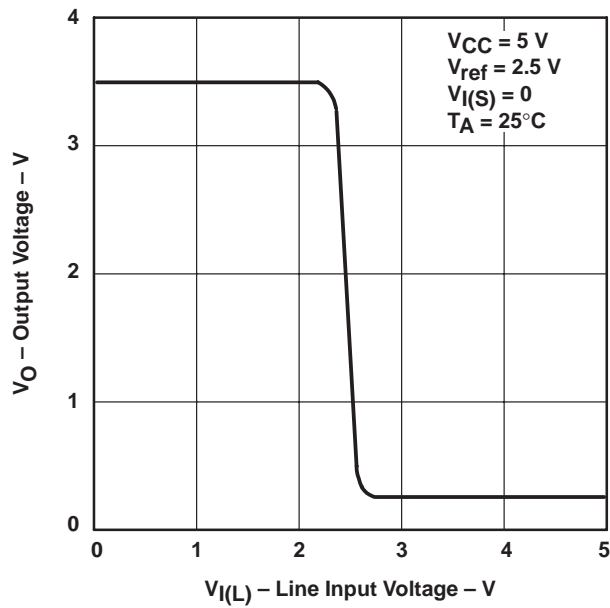

Figure 2

## APPLICATION INFORMATION

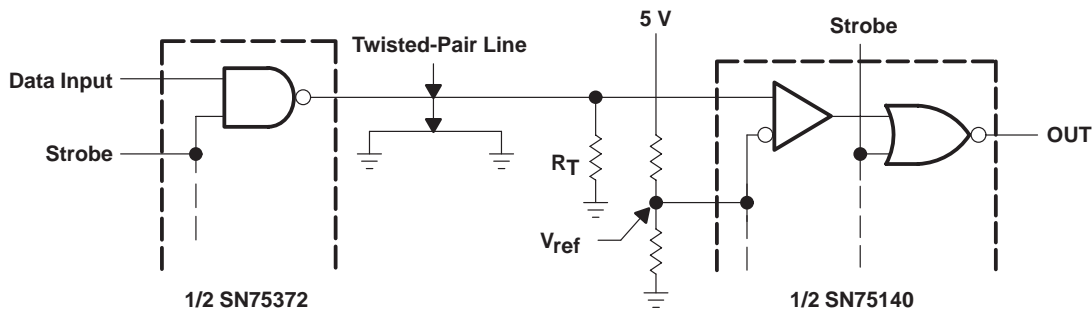
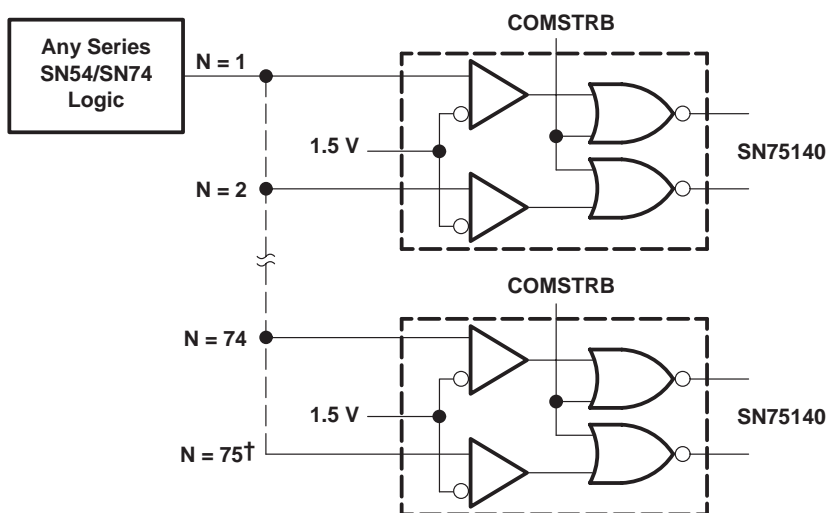

Figure 3. Line Receiver



† Although most series SN54/SN74 circuits have a >2.4-V output at 400  $\mu$ A, they typically are capable of maintaining a >2.4-V output level under a load of 7.5 mA.

Figure 4. High Fanout From Standard TTL Gate

# SN75140 DUAL LINE RECEIVER

SLLS080C – JANUARY 1977 – REVISED APRIL 1998

## APPLICATION INFORMATION

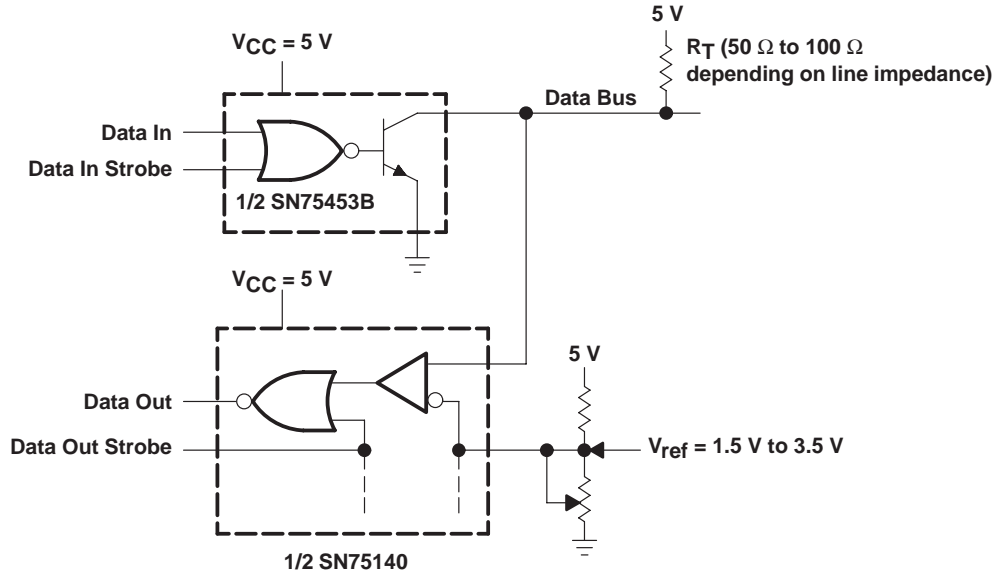

NOTE A: Using this arrangement, as many as 100 transceivers can be connected to a single data bus. The adjustable reference-voltage feature allows the noise margin to be optimized for a given system. The complete dual bus transceiver (SN75453B driver and SN75140 receiver) can be assembled in approximately the same space required by a single 16-pin package and only one power supply is required (5 V). Data in and data out are TTL compatible.

Figure 5. Dual Bus Transceiver

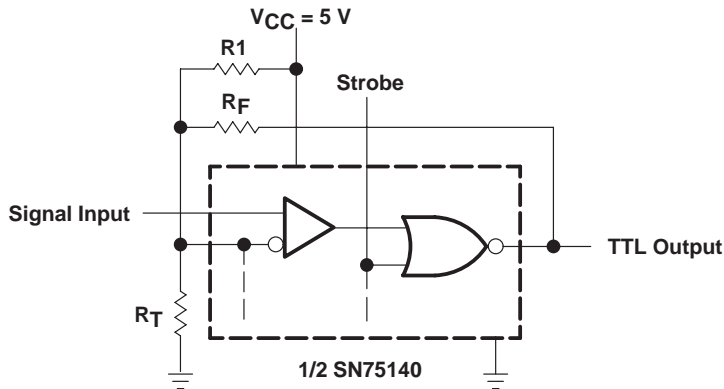
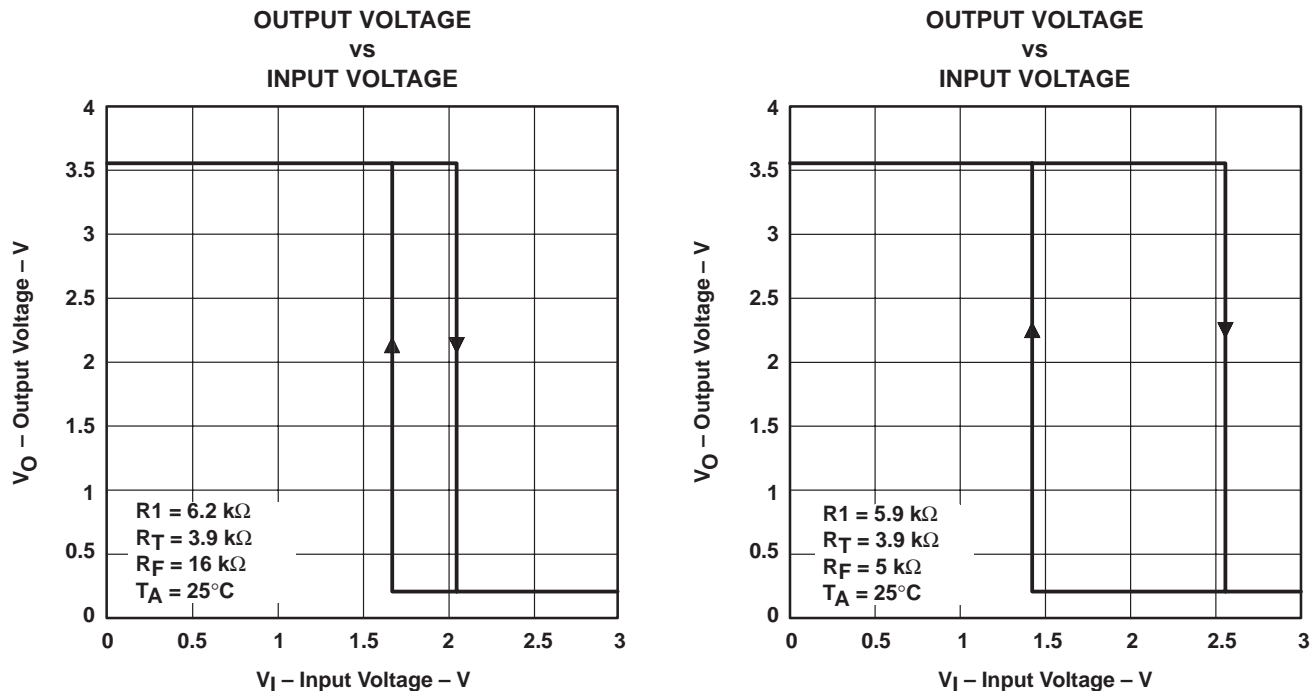

Figure 6. Schmitt Trigger

APPLICATION INFORMATION



NOTE A: Slowly changing input levels from data lines, optical detectors, and other types of transducers can be converted to standard TTL signals with this Schmitt-trigger circuit.  $R_1$ ,  $R_F$ , and  $R_T$  can be adjusted for the desired hysteresis and trigger levels.

Figure 7. Examples of Transfer Characteristics

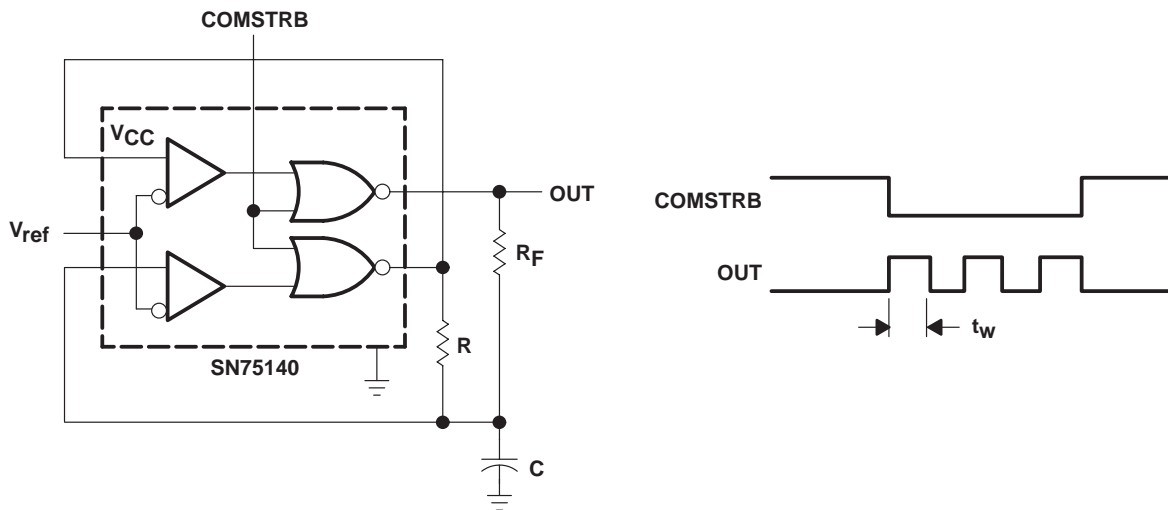

Figure 8. Gated Oscillator

APPLICATION INFORMATION

OSCILLATOR FREQUENCY  
vs  
RC TIME CONSTANT

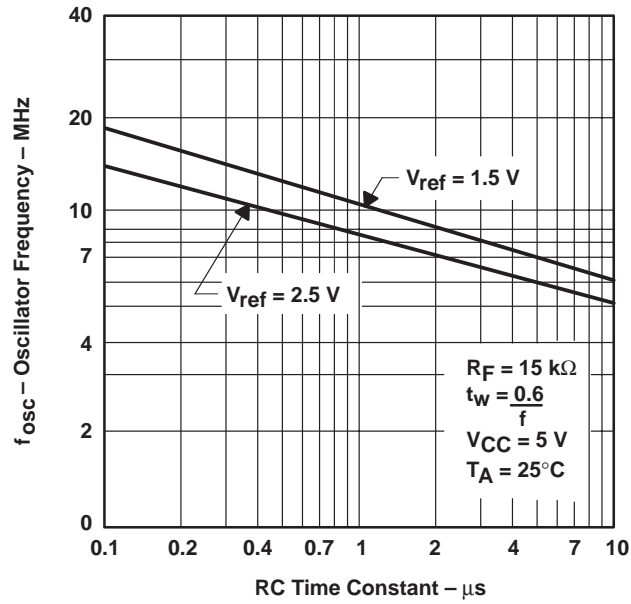

Figure 9

**PACKAGING INFORMATION**

Orderable Device	Status (1)	Package Type	Package Drawing	Pins	Package Qty	Eco Plan (2)	Lead finish/ Ball material (6)	MSL Peak Temp (3)	Op Temp (°C)	Device Marking (4/5)	Samples
SN75140P	ACTIVE	PDIP	P	8	50	RoHS & Green	NIPDAU	N / A for Pkg Type	0 to 70	SN75140P	<a href="#">Samples</a>
SN75140PSR	ACTIVE	SO	PS	8	2000	RoHS & Green	NIPDAU	Level-1-260C-UNLIM	0 to 70	A140	<a href="#">Samples</a>

(1) The marketing status values are defined as follows:

**ACTIVE:** Product device recommended for new designs.

**LIFEBUY:** TI has announced that the device will be discontinued, and a lifetime-buy period is in effect.

**NRND:** Not recommended for new designs. Device is in production to support existing customers, but TI does not recommend using this part in a new design.

**PREVIEW:** Device has been announced but is not in production. Samples may or may not be available.

**OBsolete:** TI has discontinued the production of the device.

(2) **RoHS:** TI defines "RoHS" to mean semiconductor products that are compliant with the current EU RoHS requirements for all 10 RoHS substances, including the requirement that RoHS substance do not exceed 0.1% by weight in homogeneous materials. Where designed to be soldered at high temperatures, "RoHS" products are suitable for use in specified lead-free processes. TI may reference these types of products as "Pb-Free".

**RoHS Exempt:** TI defines "RoHS Exempt" to mean products that contain lead but are compliant with EU RoHS pursuant to a specific EU RoHS exemption.

**Green:** TI defines "Green" to mean the content of Chlorine (Cl) and Bromine (Br) based flame retardants meet JS709B low halogen requirements of <=1000ppm threshold. Antimony trioxide based flame retardants must also meet the <=1000ppm threshold requirement.

(3) MSL, Peak Temp. - The Moisture Sensitivity Level rating according to the JEDEC industry standard classifications, and peak solder temperature.

(4) There may be additional marking, which relates to the logo, the lot trace code information, or the environmental category on the device.

(5) Multiple Device Markings will be inside parentheses. Only one Device Marking contained in parentheses and separated by a "~" will appear on a device. If a line is indented then it is a continuation of the previous line and the two combined represent the entire Device Marking for that device.

(6) Lead finish/Ball material - Orderable Devices may have multiple material finish options. Finish options are separated by a vertical ruled line. Lead finish/Ball material values may wrap to two lines if the finish value exceeds the maximum column width.

**Important Information and Disclaimer:**The information provided on this page represents TI's knowledge and belief as of the date that it is provided. TI bases its knowledge and belief on information provided by third parties, and makes no representation or warranty as to the accuracy of such information. Efforts are underway to better integrate information from third parties. TI has taken and continues to take reasonable steps to provide representative and accurate information but may not have conducted destructive testing or chemical analysis on incoming materials and chemicals. TI and TI suppliers consider certain information to be proprietary, and thus CAS numbers and other limited information may not be available for release.

In no event shall TI's liability arising out of such information exceed the total purchase price of the TI part(s) at issue in this document sold by TI to Customer on an annual basis.



**TAPE AND REEL INFORMATION**

**QUADRANT ASSIGNMENTS FOR PIN 1 ORIENTATION IN TAPE**

\*All dimensions are nominal

Device	Package Type	Package Drawing	Pins	SPQ	Reel Diameter (mm)	Reel Width W1 (mm)	A0 (mm)	B0 (mm)	K0 (mm)	P1 (mm)	W (mm)	Pin1 Quadrant
SN75140PSR	SO	PS	8	2000	330.0	16.4	8.35	6.6	2.4	12.0	16.0	Q1

**TAPE AND REEL BOX DIMENSIONS**

\*All dimensions are nominal

Device	Package Type	Package Drawing	Pins	SPQ	Length (mm)	Width (mm)	Height (mm)
SN75140PSR	SO	PS	8	2000	853.0	449.0	35.0

**TUBE**



\*All dimensions are nominal

Device	Package Name	Package Type	Pins	SPQ	L (mm)	W (mm)	T (μm)	B (mm)
SN75140P	P	PDIP	8	50	506	13.97	11230	4.32

## MECHANICAL DATA

PS (R-PDSO-G8)

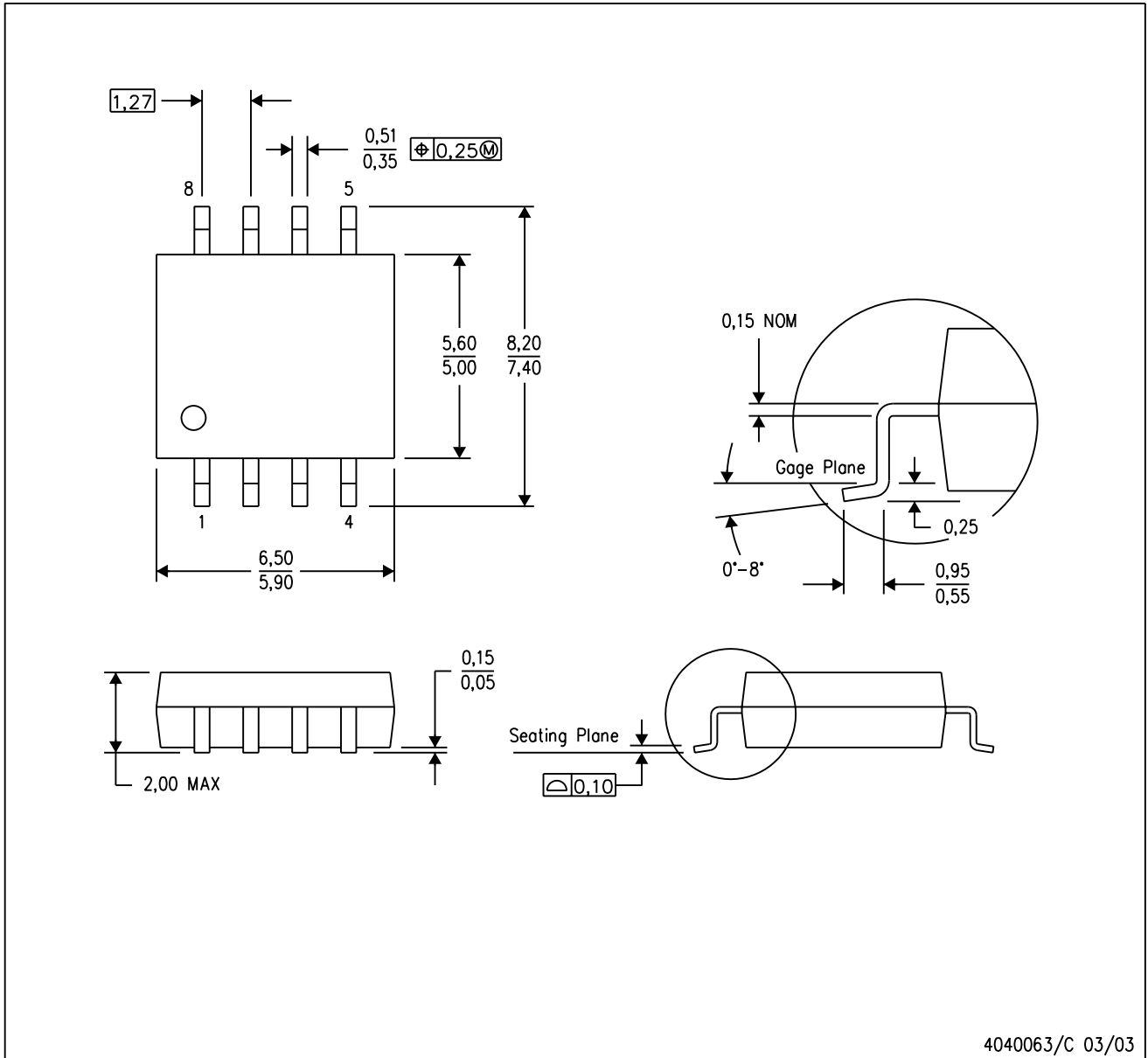
PLASTIC SMALL-OUTLINE PACKAGE



- NOTES:
- A. All linear dimensions are in millimeters.
  - B. This drawing is subject to change without notice.
  - C. Body dimensions do not include mold flash or protrusion, not to exceed 0,15.

PS (R-PDSO-G8)

PLASTIC SMALL OUTLINE

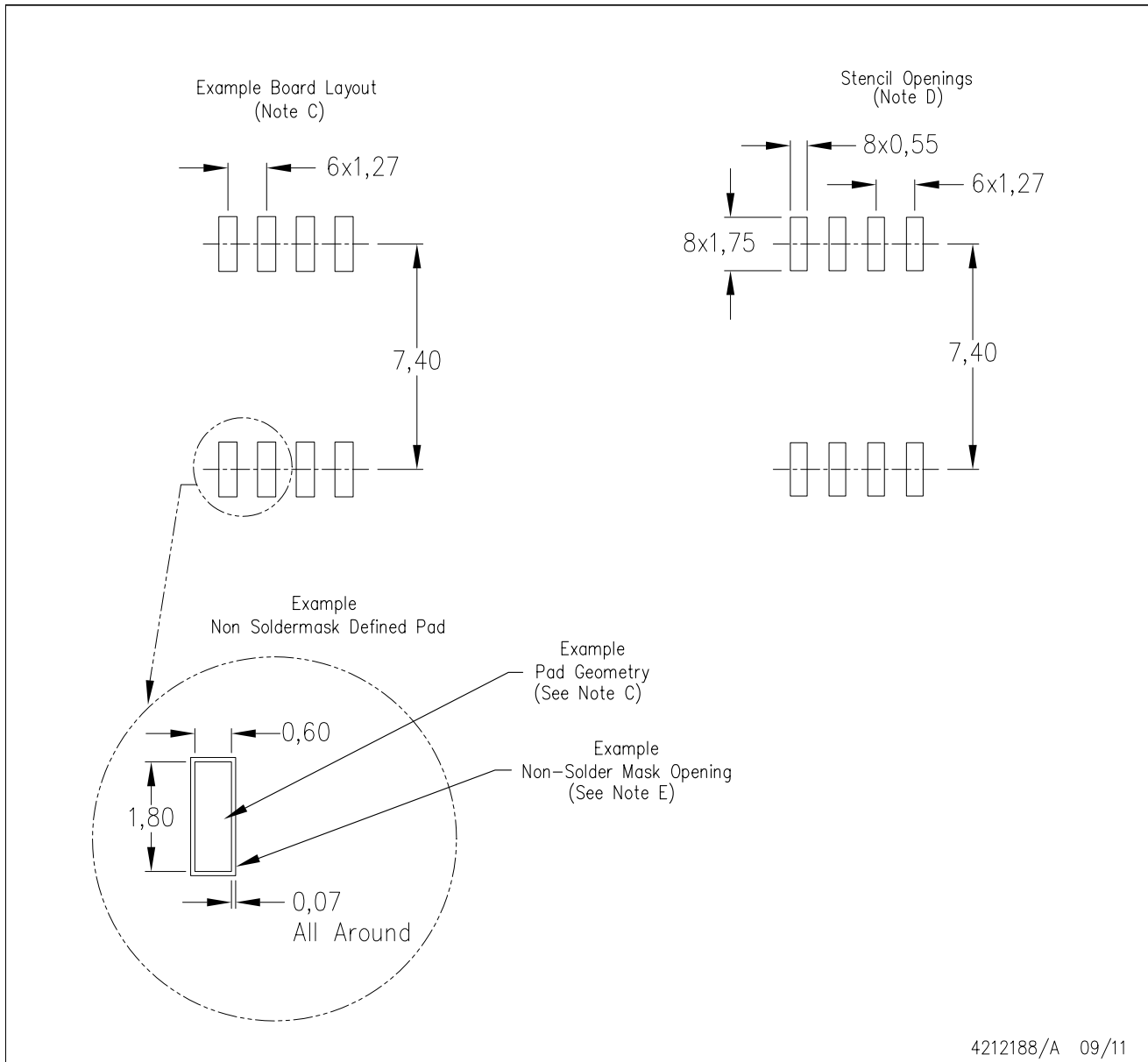

- NOTES:
- A. All linear dimensions are in millimeters.
  - B. This drawing is subject to change without notice.
  - C. Publication IPC-7351 is recommended for alternate designs.
  - D. Laser cutting apertures with trapezoidal walls and also rounding corners will offer better paste release. Customers should contact their board assembly site for stencil design recommendations. Refer to IPC-7525 for other stencil recommendations.
  - E. Customers should contact their board fabrication site for solder mask tolerances between and around signal pads.

P (R-PDIP-T8)

PLASTIC DUAL-IN-LINE PACKAGE



- NOTES:
- A. All linear dimensions are in inches (millimeters).
  - B. This drawing is subject to change without notice.
  - C. Falls within JEDEC MS-001 variation BA.

## IMPORTANT NOTICE AND DISCLAIMER

TI PROVIDES TECHNICAL AND RELIABILITY DATA (INCLUDING DATA SHEETS), DESIGN RESOURCES (INCLUDING REFERENCE DESIGNS), APPLICATION OR OTHER DESIGN ADVICE, WEB TOOLS, SAFETY INFORMATION, AND OTHER RESOURCES "AS IS" AND WITH ALL FAULTS, AND DISCLAIMS ALL WARRANTIES, EXPRESS AND IMPLIED, INCLUDING WITHOUT LIMITATION ANY IMPLIED WARRANTIES OF MERCHANTABILITY, FITNESS FOR A PARTICULAR PURPOSE OR NON-INFRINGEMENT OF THIRD PARTY INTELLECTUAL PROPERTY RIGHTS.

These resources are intended for skilled developers designing with TI products. You are solely responsible for (1) selecting the appropriate TI products for your application, (2) designing, validating and testing your application, and (3) ensuring your application meets applicable standards, and any other safety, security, regulatory or other requirements.

These resources are subject to change without notice. TI grants you permission to use these resources only for development of an application that uses the TI products described in the resource. Other reproduction and display of these resources is prohibited. No license is granted to any other TI intellectual property right or to any third party intellectual property right. TI disclaims responsibility for, and you will fully indemnify TI and its representatives against, any claims, damages, costs, losses, and liabilities arising out of your use of these resources.

TI's products are provided subject to [TI's Terms of Sale](#) or other applicable terms available either on [ti.com](http://ti.com) or provided in conjunction with such TI products. TI's provision of these resources does not expand or otherwise alter TI's applicable warranties or warranty disclaimers for TI products.

TI objects to and rejects any additional or different terms you may have proposed.

Mailing Address: Texas Instruments, Post Office Box 655303, Dallas, Texas 75265  
Copyright © 2022, Texas Instruments Incorporated