

# TPS1HB16-Q1 40V、16mΩ 单通道智能高侧开关

## 1 特性

- 具有符合面向汽车 标准
  - 温度等级 1:  $-40^{\circ}\text{C}$  至  $125^{\circ}\text{C}$
  - 器件 HBM ESD 分类等级 2
  - 器件 CDM ESD 分类等级 C4B
  - 可承受 40V 负载突降
- 单通道智能高侧开关, 具有  $16\text{m}\Omega$   $R_{\text{ON}}$  ( $T_{\text{J}} = 25^{\circ}\text{C}$ )
- 可通过 **可调电流限制** 提高系统级可靠性
  - 电流限制设定范围为  $4.4\text{A}$  至  $49\text{A}$
- 强大的集成输出保护:
  - 集成热保护
  - 接地短路和电池短路保护
  - **反向电池** 事件保护包括 FET 通过反向电流自动开启
  - 在失电和接地失效时自动关闭
  - 集成输出钳位对电感负载进行消磁
  - 可配置故障处理
- 可对模拟检测输出进行配置, 以精确测量:
  - 负载电流
  - 器件温度
- 通过 SNS 引脚提供故障指示
  - 开路负载和电池短路检测

## 2 应用

- 信息娱乐显示屏
- ADAS 模块
- 加热元件:
  - 座椅加热器
  - 火花塞
  - 油箱加热器
- 变速器控制单元
- HVAC 空调
- 车身控制模块
- 白炽灯和 LED 照明

## 3 说明

TPS1HB16-Q1 器件是一款适用于 12V 汽车系统的智能高侧开关。该器件集成了强大的保护和诊断功能, 以确保即使在汽车系统中发生短路等有害事件时也能提供输出端口保护。该器件通过**可靠的电流限制**来防止故障, 根据器件型号不同, 电流限制在  $4.4\text{A}$  至  $49\text{A}$ 。凭借较高的电流限制范围, 该器件可用于需要大瞬态电流的负载, 而低电流限制范围可为不需要高峰值电流的负载提供更好的保护。该器件能够可靠地驱动各种**负载分布**。

TPS1HB16-Q1 还能够提供可改进负载诊断的高精度模拟电流检测。通过向系统 MCU 报告负载电流和器件温度, 该器件可实现预测性维护和负载诊断, 从而延长系统寿命。

TPS1HB16-Q1 采用 HTSSOP 封装, 可减小 PCB 尺寸。

器件信息(1)

器件型号	封装	封装尺寸 (标称值)
TPS1HB16-Q1	HTSSOP (16)	5.0mm x 4.40mm

(1) 如需了解所有可用封装, 请参阅数据表末尾的可订购产品附录。

简化原理图

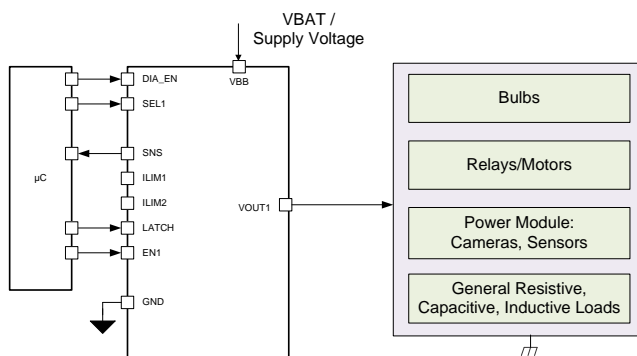

## 目录

<b>1</b>	特性 .....	<b>1</b>	9.2	Functional Block Diagram .....	<b>13</b>
<b>2</b>	应用 .....	<b>1</b>	9.3	Feature Description .....	<b>13</b>
<b>3</b>	说明 .....	<b>1</b>	9.4	Device Functional Modes .....	<b>24</b>
<b>4</b>	修订历史记录 .....	<b>2</b>	<b>10</b>	<b>Application and Implementation</b> .....	<b>26</b>
<b>5</b>	<b>Device Comparison Table</b> .....	<b>3</b>	10.1	Application Information .....	<b>26</b>
<b>6</b>	<b>Pin Configuration and Functions</b> .....	<b>3</b>	10.2	Typical Application .....	<b>29</b>
6.1	Recommended Connections for Unused Pins .....	<b>4</b>	<b>11</b>	<b>Power Supply Recommendations</b> .....	<b>32</b>
<b>7</b>	<b>Specifications</b> .....	<b>5</b>	<b>12</b>	<b>Layout</b> .....	<b>33</b>
7.1	Absolute Maximum Ratings .....	<b>5</b>	12.1	Layout Guidelines .....	<b>33</b>
7.2	ESD Ratings .....	<b>5</b>	12.2	Layout Example .....	<b>33</b>
7.3	Recommended Operating Conditions .....	<b>5</b>	<b>13</b>	器件和文档支持 .....	<b>34</b>
7.4	Thermal Information .....	<b>5</b>	13.1	文档支持 .....	<b>34</b>
7.5	Electrical Characteristics .....	<b>6</b>	13.2	接收文档更新通知 .....	<b>34</b>
7.6	SNS Timing Characteristics .....	<b>8</b>	13.3	社区资源 .....	<b>34</b>
7.7	Switching Characteristics .....	<b>9</b>	13.4	商标 .....	<b>34</b>
<b>8</b>	<b>Parameter Measurement Information</b> .....	<b>10</b>	13.5	静电放电警告 .....	<b>34</b>
<b>9</b>	<b>Detailed Description</b> .....	<b>12</b>	13.6	Glossary .....	<b>34</b>
9.1	Overview .....	<b>12</b>	<b>14</b>	机械、封装和可订购信息 .....	<b>34</b>

## 4 修订历史记录

日期	修订版本	说明
2019 年 5 月	*	初始发行版

## 5 Device Comparison Table

**Table 1. Device Options**

Device Version	Part Number	Current Limit	Current Limit Range	Overcurrent Behavior
A <sup>(1)</sup>	TPS1HB16A-Q1	Resistor Programmable	4.4 A to 22 A	Disable switch immediately
B	TPS1HB16B-Q1	Resistor Programmable	9.8 A to 49 A	Disable switch immediately

(1) Product preview; Contact TI factory for more information.

## 6 Pin Configuration and Functions

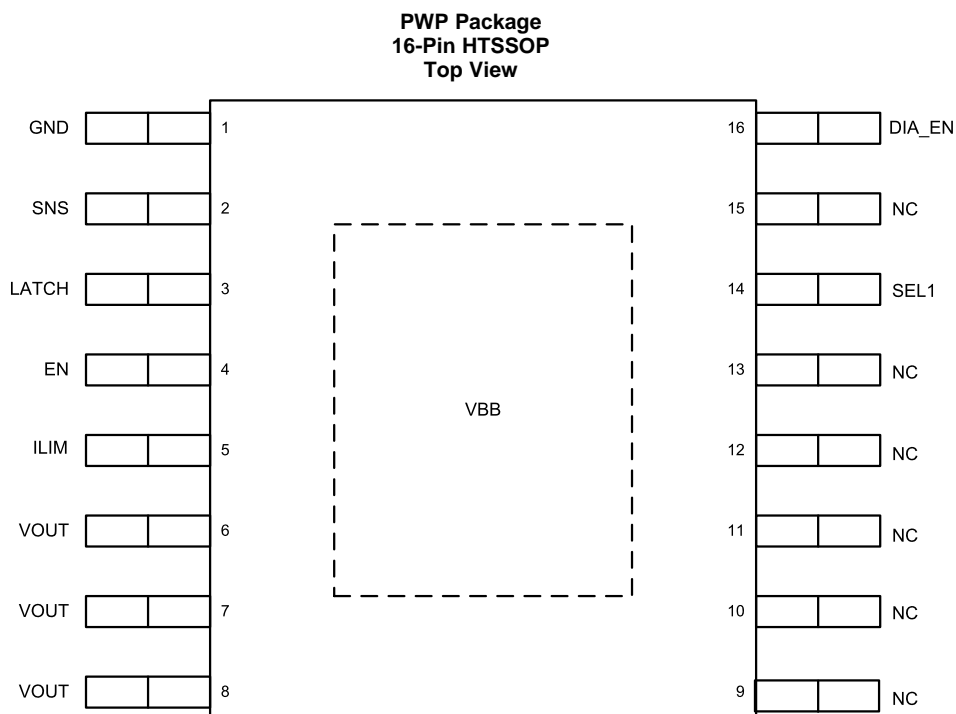

**Pin Functions**

PIN		I/O	DESCRIPTION
No.	Name		
1	GND	—	Device ground
2	SNS	O	Sense output
3	LATCH	I	Sets fault handling behavior (latched or auto-retry)
4	EN	I	Control input, active high
5	ILIM	O	Connect resistor to set current-limit threshold
6 - 8	VOUT	O	Channel output
9 - 13, 15	NC	I	No Connect, leave floating
14	SEL1	I	Diagnostics select.
16	DIA_EN	I	Diagnostic enable, active high
Exposed pad	VBB	I	Power supply input

**ADVANCE INFORMATION**

## 6.1 Recommended Connections for Unused Pins

The TPS1HB16-Q1 is designed to provide an enhanced set of diagnostic and protection features. However, if the system design only allows for a limited number of I/O connections, some pins may be considered as optional.

**Table 2. Connections for Optional Pins**

PIN NAME	CONNECTION IF NOT USED	IMPACT IF NOT USED
SNS	Ground through 1-kΩ resistor	Analog sense is not available.
LATCH	Float or ground through R <sub>PROT</sub> resistor	With LATCH unused, the device will auto-retry after a fault. If latched behavior is desired, but the system describes limited I/O, it is possible to use one microcontroller output to control the latch function of several high-side channels.
ILIM	Float	If the ILIM pin is left floating, the device will be set to the default internal current-limit threshold. This is considered a fault state for the device.
SEL1	Ground through R <sub>PROT</sub> resistor	SEL1 selects the T <sub>J</sub> sensing feature. With SEL1 unused, only current sensing and open load detection are available. If unused, must be grounded through a resistor to engage FET turn-on during reverse battery.
DIA_EN	Float or ground through R <sub>PROT</sub> resistor	With DIA_EN unused, the analog sense, open-load, and short-to-battery diagnostics are not available.

## 7 Specifications

### 7.1 Absolute Maximum Ratings

Over operating free-air temperature range (unless otherwise noted)<sup>(1)</sup>

		MIN	MAX	UNIT
Maximum continuous supply voltage, $V_{BB}$			36	V
Load dump voltage, $V_{LD}$	ISO16750-2:2010(E)		40	V
Reverse battery voltage, $V_{Rev}$ , $t \leq 3$ minutes		-18		V
Enable pin voltage, $V_{EN}$		-1	7	V
LATCH pin voltage, $V_{LATCH}$		-1	7	V
Diagnostic Enable pin voltage, $V_{DIA\_EN}$		-1	7	V
Sense pin voltage, $V_{SNS}$		-1	18	V
Select pin voltage, $V_{SEL1}$		-1	7	V
Reverse ground current, $I_{GND}$		$V_{BB} < 0$ V		-50 mA
Energy dissipation during turnoff, $E_{TOFF}$		Single pulse, $L_{OUT} = 5$ mH, $T_{J,start} = 125^\circ\text{C}$		TBD <sup>(2)</sup> mJ
Energy dissipation during turnoff, $E_{TOFF}$		Repetitive pulse, $L_{OUT} = 5$ mH, $T_{J,start} = 125^\circ\text{C}$		TBD <sup>(2)</sup> mJ
Maximum junction temperature, $T_J$			150	$^\circ\text{C}$
Storage temperature, $T_{stg}$		-65	150	$^\circ\text{C}$

- (1) Stresses beyond those listed under *Absolute Maximum Ratings* may cause permanent damage to the device. These are stress ratings only, which do not imply functional operation of the device at these or any other conditions beyond those indicated under *Recommended Operating Conditions*. Exposure to absolute maximum rated conditions for extended periods may affect device reliability.
- (2) For further details, see the section regarding switch-off of an inductive load.

### 7.2 ESD Ratings

				VALUE	UNIT
$V_{(ESD)}$	Electrostatic discharge	Human-body model (HBM), per AEC Q100-002 <sup>(1)</sup>	All pins except $V_{BB}$ and $V_{OUT}$	$\pm 2000$	V
			$V_{BB}$ and $V_{OUT}$	$\pm 4000$	
		Charged-device model (CDM), per AEC Q100-011	All pins	$\pm 750$	

- (1) AEC-Q100-002 indicates that HBM stressing shall be in accordance with the ANSI/ESDA/JEDEC JS-001 specifications.

### 7.3 Recommended Operating Conditions

over operating free-air temperature range (unless otherwise noted)<sup>(1)</sup>

		MIN	MAX	UNIT
$V_{BB}$	Nominal supply voltage <sup>(1)</sup>	6	18	V
$V_{BB}$	Extended supply voltage <sup>(2)</sup>	3	28	V
$V_{EN}$	Enable voltage	-1	5.5	V
$V_{LATCH}$	LATCH voltage	-1	5.5	V
$V_{DIA\_EN}$	Diagnostic Enable voltage	-1	5.5	V
$V_{SEL1}$	Select voltage	-1	5.5	V
$V_{SNS}$	Sense voltage	-1	7	V
$T_A$	Operating free-air temperature	-40	125	$^\circ\text{C}$

- (1) All operating voltage conditions are measured with respect to device GND
- (2) Device will function within extended operating range, however some parametric values might not apply

### 7.4 Thermal Information

THERMAL METRIC		TPS1HB16-Q1	UNIT
		PWP (HTSSOP)	
		16 PINS	
$R_{\theta JA}$	Junction-to-ambient thermal resistance	34.3	$^\circ\text{C}/\text{W}$
$R_{\theta JC(top)}$	Junction-to-case (top) thermal resistance	31.2	$^\circ\text{C}/\text{W}$

**Thermal Information (continued)**

THERMAL METRIC		TPS1HB16-Q1	UNIT
		PWP (HTSSOP)	
		16 PINS	
$R_{\theta JB}$	Junction-to-board thermal resistance	10.8	°C/W
$\Psi_{JT}$	Junction-to-top characterization parameter	2.4	°C/W
$\Psi_{JB}$	Junction-to-board characterization parameter	10.8	°C/W
$R_{\theta JC(bot)}$	Junction-to-case (bottom) thermal resistance	1.6	°C/W

**7.5 Electrical Characteristics**
 $V_{BB} = 6\text{ V to }18\text{ V}$ ,  $T_J = -40^\circ\text{C to }150^\circ\text{C}$  (unless otherwise noted)

PARAMETER		TEST CONDITIONS	MIN	TYP	MAX	UNIT
<b>INPUT VOLTAGE AND CURRENT</b>						
$V_{DSClamp}$	$V_{DS}$ clamp voltage		40		46	V
$V_{BBCLAMP}$	$V_{BB}$ clamp voltage		58		76	V
$V_{UVLOF}$	$V_{BB}$ undervoltage lockout falling	Measured with respect to the GND pin of the device	2.0		3	V
$V_{UVLOR}$	$V_{BB}$ undervoltage lockout rising	Measured with respect to the GND pin of the device	2.2		3	V
$I_{SB}$	Standby current (total device leakage including MOSFET channel)	$V_{BB} = 13.5\text{ V}$ , $T_J = 25^\circ\text{C}$ $V_{EN} = V_{DIA\_EN} = 0\text{ V}$ , $V_{OUT} = 0\text{ V}$			0.1	$\mu\text{A}$
		$V_{BB} = 13.5\text{ V}$ , $T_J = 85^\circ\text{C}$ , $V_{EN} = V_{DIA\_EN} = 0\text{ V}$ , $V_{OUT} = 0\text{ V}$			0.5	$\mu\text{A}$
$I_{L\_NOM}$	Continuous load current	$T_{AMB} = 70^\circ\text{C}$		7		A
$I_{OUT(standby)}$	Output leakage current	$V_{BB} = 13.5\text{ V}$ , $T_J = 25^\circ\text{C}$ $V_{EN} = V_{DIA\_EN} = 0\text{ V}$ , $V_{OUT} = 0\text{ V}$		0.01	0.5	$\mu\text{A}$
		$V_{BB} = 13.5\text{ V}$ , $T_J = 125^\circ\text{C}$ $V_{EN} = V_{DIA\_EN} = 0\text{ V}$ , $V_{OUT} = 0\text{ V}$			1.5	$\mu\text{A}$
$I_{DIA}$	Current consumption in diagnostic mode	$V_{BB} = 13.5\text{ V}$ , $I_{SNS} = 0\text{ mA}$ $V_{EN} = 0\text{ V}$ , $V_{DIA\_EN} = 5\text{ V}$ , $V_{OUT} = 0\text{ V}$		3	6	mA
$I_Q$	Quiescent current	$V_{BB} = 13.5\text{ V}$ $V_{EN} = V_{DIA\_EN} = 5\text{ V}$ , $I_{OUT} = 0\text{ A}$		3	6	mA
$t_{STBY}$	Standby mode delay time	$V_{EN} = V_{DIA\_EN} = 0\text{ V}$ to standby	12	17	22	ms
<b>RON CHARACTERISTICS</b>						
$R_{ON}$	On-resistance (Includes MOSFET and package)	$T_J = 25^\circ\text{C}$ , $6\text{ V} \leq V_{BB} \leq 28\text{ V}$		16		$\text{m}\Omega$
		$T_J = 150^\circ\text{C}$ , $6\text{ V} \leq V_{BB} \leq 28\text{ V}$			32	$\text{m}\Omega$
		$T_J = 25^\circ\text{C}$ , $3\text{ V} \leq V_{BB} \leq 6\text{ V}$			30	$\text{m}\Omega$
$R_{ON(REV)}$	On-resistance during reverse polarity	$T_J = 25^\circ\text{C}$ , $-18\text{ V} \leq V_{BB} \leq -8\text{ V}$		16		$\text{m}\Omega$
		$T_J = 105^\circ\text{C}$ , $-18\text{ V} \leq V_{BB} \leq -8\text{ V}$			32	$\text{m}\Omega$
<b>CURRENT SENSE CHARACTERISTICS</b>						
$K_{SNS}$	Current sense ratio $I_{OUT} / I_{SNS}$	$I_{OUT} = 1\text{ A}$		3000		

**Electrical Characteristics (continued)**
 $V_{BB} = 6\text{ V to }18\text{ V}$ ,  $T_J = -40^\circ\text{C to }150^\circ\text{C}$  (unless otherwise noted)

PARAMETER		TEST CONDITIONS		MIN	TYP	MAX	UNIT
$I_{SNSI}$	Current sense current and accuracy	$V_{EN} = V_{DIA\_EN} = 5\text{ V}$ , $V_{SEL1} = 0\text{ V}$	$I_{OUT} = 12\text{ A}$		4.000		mA
					-4	4	%
			$I_{OUT} = 3\text{ A}$		1.000		mA
					-4	4	%
			$I_{OUT} = 1\text{ A}$		0.333		mA
					-4	4	%
			$I_{OUT} = 300\text{ mA}$		0.100		mA
	-10	10	%				
$I_{OUT} = 100\text{ mA}$		0.033		mA			
		-25	25	%			
$I_{OUT} = 50\text{ mA}$		0.017		mA			
		-35	35	%			
<b>TJ SENSE CHARACTERISTICS</b>							
$I_{SNSST}$	Temperature sense current	$V_{DIA\_EN} = 5\text{ V}$ , $V_{SEL1} = 5\text{ V}$	$T_J = -40^\circ\text{C}$	0.01	0.12	0.38	mA
			$T_J = 25^\circ\text{C}$	0.72	0.85	0.98	mA
			$T_J = 85^\circ\text{C}$	1.25	1.52	1.79	mA
			$T_J = 125^\circ\text{C}$	1.61	1.96	2.31	mA
			$T_J = 150^\circ\text{C}$	1.80	2.25	2.70	mA
$dI_{SNSST}/dT$	Coefficient			0.0112		mA/°C	
<b>SNS CHARACTERISTICS</b>							
$I_{SNSFH}$	$I_{SNS}$ fault high-level	$V_{DIA\_EN} = 5\text{ V}$ , $V_{SEL1} = 0\text{ V}$		4	4.5	5.3	mA
$I_{SNSleak}$	$I_{SNS}$ leakage	$V_{DIA\_EN} = 0\text{ V}$				1	μA
<b>CURRENT LIMIT CHARACTERISTICS</b>							
$I_{CL}$	Current limit threshold	Device Version A, $T_J = -40^\circ\text{C to }150^\circ\text{C}$	$R_{LIM} = \text{GND, open, or out of range}$		28.6		A
			$R_{LIM} = 5\text{ k}\Omega$	16.5	22	27.5	A
			$R_{LIM} = 25\text{ k}\Omega$	3.4	4.4	5.5	A
		Device Version B, $T_J = -40^\circ\text{C to }150^\circ\text{C}$	$R_{LIM} = \text{GND, open, or out of range}$		70		A
			$R_{LIM} = 5\text{ k}\Omega$	33.3	49	55.9	A
			$R_{LIM} = 25\text{ k}\Omega$	7.57	9.8	12.6	A
$K_{CL}$	Current Limit Ratio	Version A		82.5	110	137.5	A * kΩ
		Version B		166.5	245	315	A * kΩ
<b>FAULT CHARACTERISTICS</b>							
$V_{OL}$	Open-load (OL) detection voltage	$V_{EN} = 0\text{ V}$ , $V_{DIA\_EN} = 5\text{ V}$ , $V_{SEL1} = 0\text{ V}$		2	3	4	V
$t_{OL1}$	OL and STB indication-time from EN falling	$V_{EN} = 5\text{ V to }0\text{ V}$ , $V_{DIA\_EN} = 5\text{ V}$ , $V_{SEL1} = 0\text{ V}$ $I_{OUT} = 0\text{ mA}$ , $V_{OUT} = 4\text{ V}$		300	500	700	μs
$t_{OL2}$	OL and STB indication-time from DIA_EN rising	$V_{EN} = 0\text{ V}$ , $V_{DIA\_EN} = 0\text{ V to }5\text{ V}$ , $V_{SEL1} = 0\text{ V}$ $I_{OUT} = 0\text{ mA}$ , $V_{OUT} = 4\text{ V}$		2	20	50	μs
$t_{OL3}$	OL and STB indication-time from VOUT rising	$V_{EN} = 0\text{ V}$ , $V_{DIA\_EN} = 5\text{ V}$ , $V_{SEL1} = 0\text{ V}$ $I_{OUT} = 0\text{ mA}$ , $V_{OUT} = 0\text{ V to }4\text{ V}$		2	20	50	μs
$T_{ABS}$	Thermal shutdown			150			°C
$T_{REL}$	Relative thermal shutdown				60		°C
$T_{HYS}$	Thermal shutdown hysteresis			20	25	30	°C

### Electrical Characteristics (continued)

V<sub>BB</sub> = 6 V to 18 V, T<sub>J</sub> = -40°C to 150°C (unless otherwise noted)

PARAMETER		TEST CONDITIONS	MIN	TYP	MAX	UNIT
t <sub>FAULT</sub>	Fault shutdown indication-time	V <sub>DIA_EN</sub> = 5 V Time between switch shutdown and I <sub>SNS</sub> settling at I <sub>SNSFH</sub>			50	μs
t <sub>RETRY</sub>	Retry time	Time from fault shutdown until switch re-enable (thermal shutdown or current limit).	1	2	3	ms
<b>EN PIN CHARACTERISTICS</b>						
V <sub>IL, EN</sub>	Input voltage low-level	No GND network diode			0.8	V
V <sub>IH, EN</sub>	Input voltage high-level	No GND network diode	2.0			V
V <sub>IHYS, EN</sub>	Input voltage hysteresis			350		mV
R <sub>EN</sub>	Internal pulldown resistor		0.5	1	2	MΩ
I <sub>IL, EN</sub>	Input current low-level	V <sub>EN</sub> = 0.8 V		0.8		μA
I <sub>IH, EN</sub>	Input current high-level	V <sub>EN</sub> = 5 V		5.0		μA
<b>DIA_EN PIN CHARACTERISTICS</b>						
V <sub>IL, DIA_EN</sub>	Input voltage low-level	No GND network diode			0.8	V
V <sub>IH, DIA_EN</sub>	Input voltage high-level	No GND network diode	2.0			V
V <sub>IHYS, DIA_EN</sub>	Input voltage hysteresis			350		mV
R <sub>DIA_EN</sub>	Internal pulldown resistor		0.5	1	2	MΩ
I <sub>IL, DIA_EN</sub>	Input current low-level	V <sub>DIA_EN</sub> = 0.8 V		0.8		μA
I <sub>IH, DIA_EN</sub>	Input current high-level	V <sub>DIA_EN</sub> = 5 V		5.0		μA
<b>SEL1 PIN CHARACTERISTICS</b>						
V <sub>IL, SEL1</sub>	Input voltage low-level	No GND network diode			0.8	V
V <sub>IH, SEL1</sub>	Input voltage high-level	No GND network diode	2.0			V
V <sub>IHYS, SEL1</sub>	Input voltage hysteresis			350		mV
R <sub>SEL1</sub>	Internal pulldown resistor		0.5	1	2	MΩ
I <sub>IL, SEL1</sub>	Input current low-level	V <sub>SEL1</sub> = 0.8 V		0.8		μA
I <sub>IH, SEL1</sub>	Input current high-level	V <sub>SEL1</sub> = 5 V		5.0		μA
<b>LATCH PIN CHARACTERISTICS</b>						
V <sub>IL, LATCH</sub>	Input voltage low-level	No GND network diode			0.8	V
V <sub>IH, LATCH</sub>	Input voltage high-level	No GND network diode	2.0			V
V <sub>IHYS, LATCH</sub>	Input voltage hysteresis			350		mV
R <sub>LATCH</sub>	Internal pulldown resistor		0.5	1	2	MΩ
I <sub>IL, LATCH</sub>	Input current low-level	V <sub>LATCH</sub> = 0.8 V		0.8		μA
I <sub>IH, LATCH</sub>	Input current high-level	V <sub>LATCH</sub> = 5 V		5		μA

### 7.6 SNS Timing Characteristics

V<sub>BB</sub> = 6 V to 18 V, T<sub>J</sub> = -40°C to +150°C (unless otherwise noted)

PARAMETER		TEST CONDITIONS	MIN	TYP	MAX	UNIT
<b>SNS TIMING - CURRENT SENSE</b>						
t <sub>SNSION1</sub>	Settling time from rising edge of DIA_EN	V <sub>EN</sub> = 5 V, V <sub>DIA_EN</sub> = 0 V to 5 V R <sub>SNS</sub> = 1 kΩ, R <sub>L</sub> ≤ 4 Ω			40	μs
t <sub>SNSION2</sub>	Settling time from rising edge of EN and DIA_EN	V <sub>EN</sub> = V <sub>DIA_EN</sub> = 0 V to 5 V R <sub>SNS</sub> = 1 kΩ, R <sub>L</sub> ≤ 4 Ω			200	μs
t <sub>SNSION3</sub>	Settling time from rising edge of EN	V <sub>EN</sub> = 0 V to 5 V, V <sub>DIA_EN</sub> = 5 V R <sub>SNS</sub> = 1 kΩ, R <sub>L</sub> ≤ 4 Ω			165	μs
t <sub>SNSIOFF1</sub>	Settling time from falling edge of DIA_EN	V <sub>EN</sub> = 5 V, V <sub>DIA_EN</sub> = 5 V to 0 V R <sub>SNS</sub> = 1 kΩ, R <sub>L</sub> ≤ 4 Ω			20	μs

## SNS Timing Characteristics (continued)

 $V_{BB} = 6\text{ V to }18\text{ V}$ ,  $T_J = -40^\circ\text{C to }+150^\circ\text{C}$  (unless otherwise noted)

PARAMETER		TEST CONDITIONS	MIN	TYP	MAX	UNIT
$t_{SETTLEH}$	Settling time from rising edge of load step	$V_{EN} = 5\text{ V}$ , $V_{DIA\_EN} = 5\text{ V}$ $R_{SNS} = 1\text{ k}\Omega$ , $I_{OUT} = 1\text{ A to }5\text{ A}$			20	$\mu\text{s}$
$t_{SETTLEL}$	Settling time from falling edge of load step	$V_{EN} = 5\text{ V}$ , $V_{DIA\_EN} = 5\text{ V}$ $R_{SNS} = 1\text{ k}\Omega$ , $I_{OUT} = 5\text{ A to }1\text{ A}$			20	$\mu\text{s}$
<b>SNS TIMING - TEMPERATURE SENSE</b>						
$t_{SNSTON1}$	Settling time from rising edge of DIA_EN	$V_{EN} = 5\text{ V}$ , $V_{DIA\_EN} = 0\text{ V to }5\text{ V}$ $R_{SNS} = 1\text{ k}\Omega$			40	$\mu\text{s}$
$t_{SNSTON2}$	Settling time from rising edge of DIA_EN	$V_{EN} = 0\text{ V}$ , $V_{DIA\_EN} = 0\text{ V to }5\text{ V}$ $R_{SNS} = 1\text{ k}\Omega$			70	$\mu\text{s}$
$t_{SNSTOFF}$	Settling time from falling edge of DIA_EN	$V_{EN} = X$ , $V_{DIA\_EN} = 5\text{ V to }0\text{ V}$ $R_{SNS} = 1\text{ k}\Omega$			20	$\mu\text{s}$
<b>SNS TIMING - MULTIPLEXER</b>						
$t_{MUX}$	Settling time from temperature sense to current sense	$V_{EN} = 5\text{ V}$ , $V_{DIA\_EN} = 5\text{ V}$ $V_{SEL1} = 5\text{ V to }0\text{ V}$ $R_{SNS} = 1\text{ k}\Omega$ , $R_L \leq 4\ \Omega$			60	$\mu\text{s}$
	Settling time from current sense to temperature sense	$V_{EN} = 5\text{ V}$ , $V_{DIA\_EN} = 5\text{ V}$ $V_{SEL1} = 0\text{ V to }5\text{ V}$ $R_{SNS} = 1\text{ k}\Omega$ , $R_L \leq 4\ \Omega$			60	$\mu\text{s}$

## 7.7 Switching Characteristics

 $V_{BB} = 13.5\text{ V}$ ,  $T_J = -40^\circ\text{C to }+150^\circ\text{C}$  (unless otherwise noted)

PARAMETER		TEST CONDITIONS	MIN	TYP	MAX	UNIT
$t_{DR}$	Turnon delay time (from Active)	$V_{BB} = 13.5\text{ V}$ , $R_L \leq 4\ \Omega$ , 50% EN rising to 10% $V_{OUT}$ rising	20	60	100	$\mu\text{s}$
$t_{DF}$	Turnoff delay time	$V_{BB} = 13.5\text{ V}$ , $R_L \leq 4\ \Omega$ , 50% EN falling to 90% $V_{OUT}$ Falling	20	60	100	$\mu\text{s}$
$SR_R$	$V_{OUT}$ rising slew rate	$V_{BB} = 13.5\text{ V}$ , 20% to 80% of $V_{OUT}$ . $R_L \leq 4\ \Omega$	0.1	0.4	0.7	$\text{V}/\mu\text{s}$
$SR_F$	$V_{OUT}$ falling slew rate	$V_{BB} = 13.5\text{ V}$ , 80% to 20% of $V_{OUT}$ . $R_L \leq 4\ \Omega$	0.1	0.4	0.7	$\text{V}/\mu\text{s}$
$t_{ON}$	Turnon time (active)	$V_{BB} = 13.5\text{ V}$ , $R_L \leq 4\ \Omega$ , 50% EN rising to 80% $V_{OUT}$ rising	39	94	235	$\mu\text{s}$
$t_{OFF}$	Turnoff time	$V_{BB} = 13.5\text{ V}$ , $R_L \leq 4\ \Omega$	39	94	235	$\mu\text{s}$
$t_{ON} - t_{OFF}$	Turnon and turnoff matching	200-us enable pulse	-50	0	50	$\mu\text{s}$
$E_{ON}$	Switching energy losses during turnon	$V_{BB} = 13.5\text{ V}$ , $R_L \leq 4\ \Omega$		0.7		mJ
$E_{OFF}$	Switching energy losses during turnoff	$V_{BB} = 13.5\text{ V}$ , $R_L \leq 4\ \Omega$		0.7		mJ

## 8 Parameter Measurement Information



图 1. Parameter Definitions



(1) Rise and fall time of  $V_{EN}$  is 100 ns.

图 2. Switching Characteristics Definitions

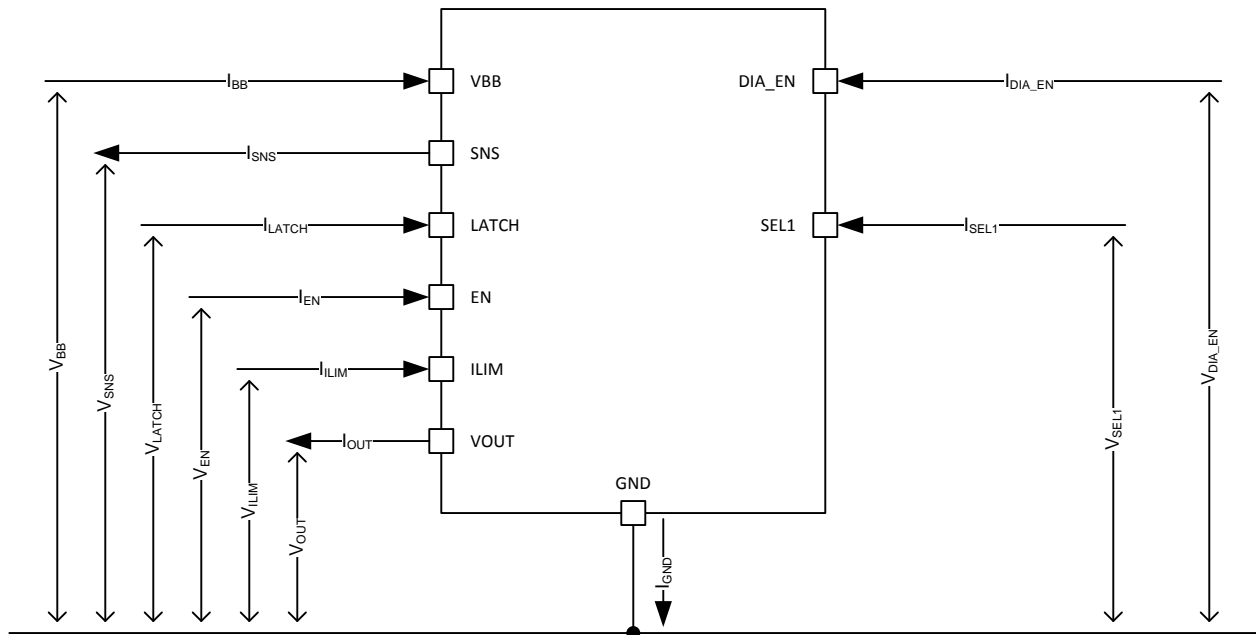
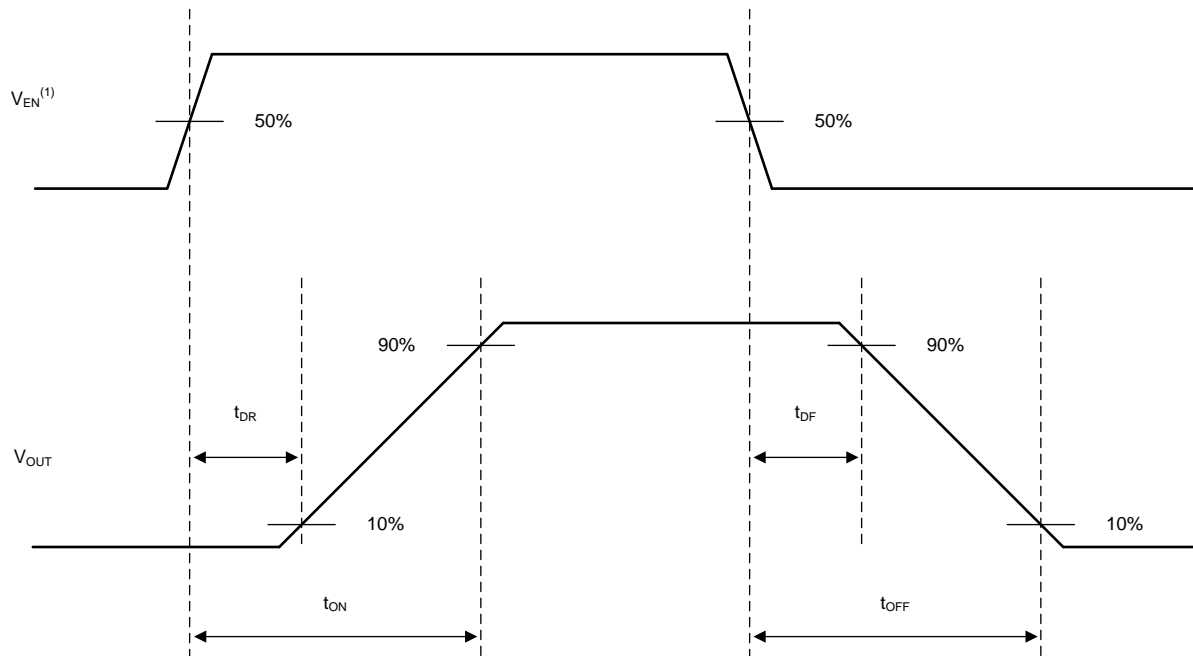
Parameter Measurement Information (接下页)

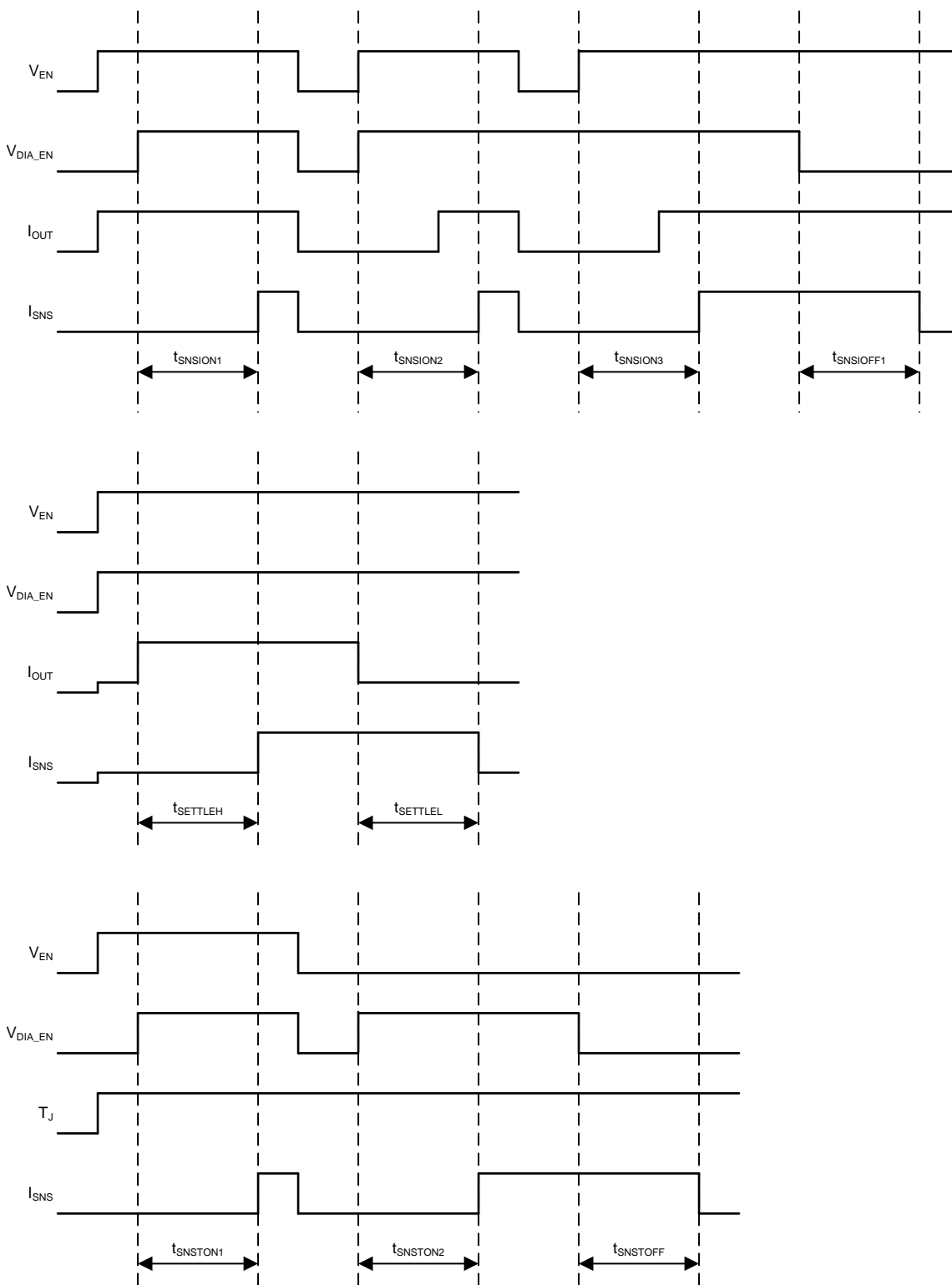

NOTES: Rise and fall times of control signals are 100 ns. Control signals include: EN, DIA\_EN, SEL1  
SEL1 pin must be set to the appropriate value.

图 3. SNS Timing Characteristics Definitions

ADVANCE INFORMATION

## 9 Detailed Description

### 9.1 Overview

The TPS1HB16-Q1 device is a single-channel smart high-side switch intended for use with 12-V automotive batteries. Many protection and diagnostic features are integrated in the device.

Diagnostics features include the analog SNS output that is capable of providing a signal that is proportional to load current or device temperature. The high-accuracy load current sense allows for diagnostics of complex loads.

This device includes protection through thermal shutdown, current limiting, transient withstand, and reverse battery operation. For more details on the protection features, refer to the [Feature Description](#) and [Application Information](#) sections of the document.

The TPS1HB16-Q1 is one device in a family of TI high side switches. For each device, the part number indicates elements of the device behavior. [图 4](#) gives an example of the device nomenclature.

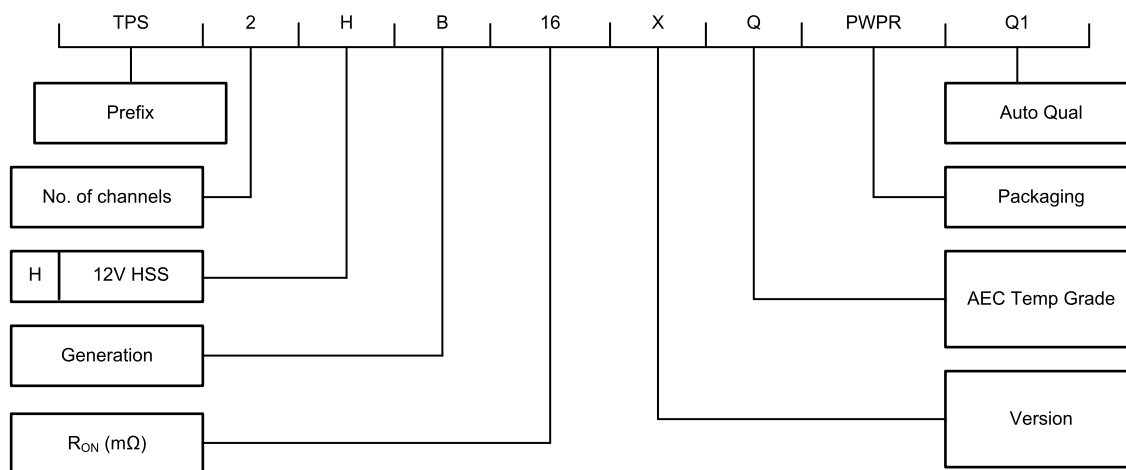

**图 4. Naming Convention**

## 9.2 Functional Block Diagram

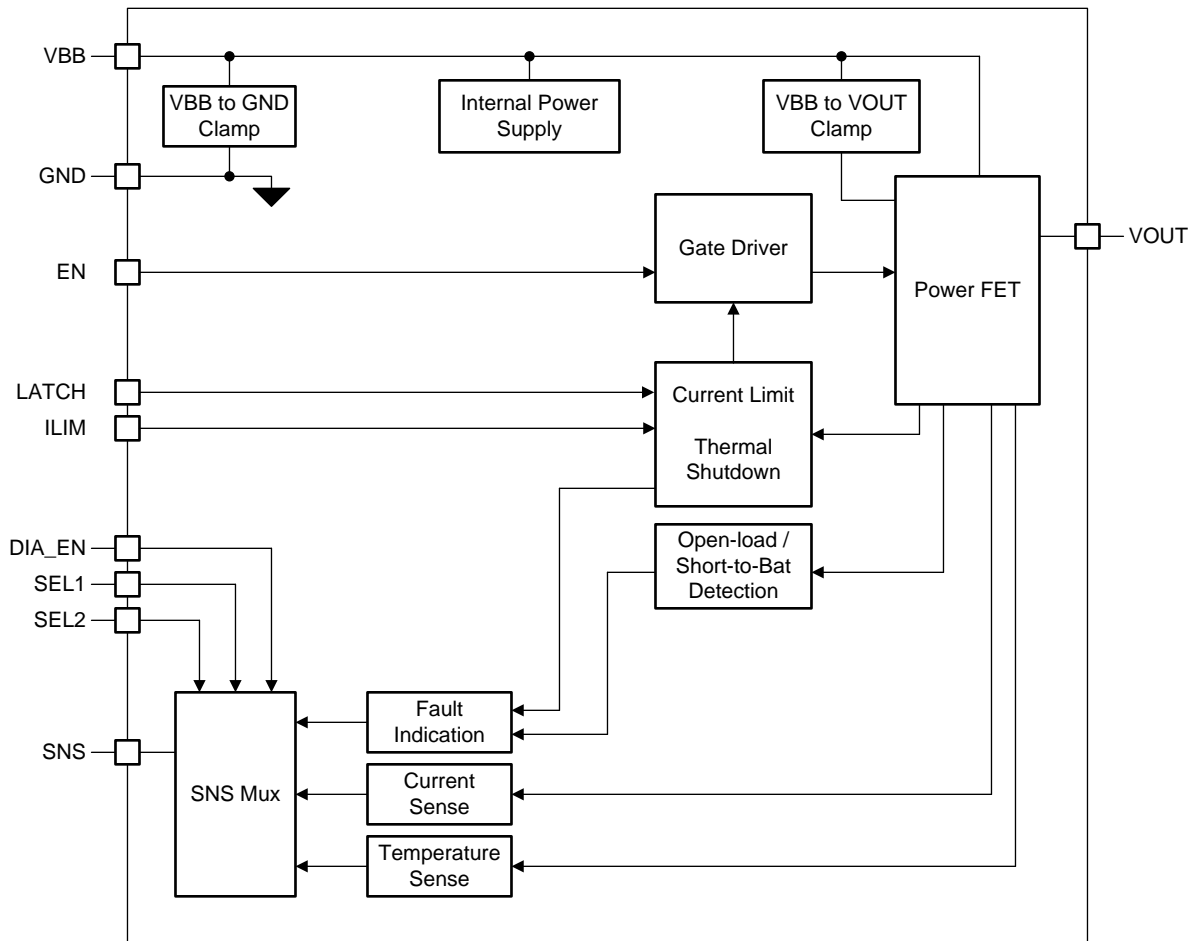

## 9.3 Feature Description

### 9.3.1 Protection Mechanisms

The TPS1HB16-Q1 is designed to operate in the automotive environment. The protection mechanisms allow the device to be robust against many system-level events such as load dump, reverse battery, short-to-ground, and more.

There are two protection features which, if triggered, will cause the switch to automatically disable:

- Thermal Shutdown
- Current Limit

When any of these protections are triggered, the device will enter the FAULT state. In the FAULT state, the fault indication will be available on the SNS pin (see the [Diagnostic Mechanisms](#) section of the data sheet for more details).

The switch is no longer held off and the fault indication is reset when all of the below conditions are met:

- LATCH pin is low
- $t_{RETRY}$  has expired
- All faults are cleared (thermal shutdown, current limit)

#### 9.3.1.1 Thermal Shutdown

The TPS1HB16-Q1 includes a temperature sensor on the power FET and also within the controller portion of the device. There are two cases that the device will consider to be a thermal shutdown fault:

## Feature Description (接下页)

- $T_{J,FET} > T_{ABS}$
- $(T_{J,FET} - T_{J,controller}) > T_{REL}$

After the fault is detected, the switch will turn off. If  $T_{J,FET}$  passes  $T_{ABS}$ , the fault is cleared when the switch temperature decreases by the hysteresis value,  $T_{HYS}$ . If instead the  $T_{REL}$  threshold is exceeded, the fault is cleared after  $T_{RETRY}$  passes.

### 9.3.1.2 Current Limit

When  $I_{OUT}$  reaches the current limit threshold,  $I_{CL}$ , the channel will switch off immediately. The  $I_{CL}$  value will vary with slew rate and a fast current increase that occurs during a powered-on short circuit can temporarily go above the specified  $I_{CL}$  value. When the switch is in the FAULT state it will output an output current  $I_{SNSFH}$  on the SNS pin.

During a short circuit event, the device will hit the  $I_{CL}$  value that is listed in the Electrical Characteristics table (for the given device version and  $R_{ILIM}$ ) and then turn the output off to protect the device. The device will register a short circuit event when the output current exceeds  $I_{CL}$ , however the measured maximum current may exceed the  $I_{CL}$  value due to the TPS1HB16-Q1 deglitch filter and turn-off time. The device is guaranteed to protect itself during a short circuit event over the nominal supply voltage range (as defined in the Electrical Characteristics table) at 125°C.

#### 9.3.1.2.1 Current Limit Foldback

Version B of the TPS1HB16-Q1 implements a current limit foldback feature that is designed to protect the device in the case of a long-term fault condition. If the device undergoes fault shutdown events (either of thermal shutdown or current limit) seven consecutive times, the current limit will be reduced to half of the original value. The device will revert back to the original current limit threshold if either of the following occurs:

- The device goes to standby mode.
- The switch turns on and turns off without any fault occurring.

Version A does not implement the current limit foldback due to the lower current limit causing less harm during repetitive long-term faults.

#### 9.3.1.2.2 Programmable Current Limit

All versions of the TPS1HB16-Q1 include an adjustable current limit. Some applications (for example, incandescent bulbs) will require a high current limit while other applications can benefit from a lower current limit threshold. In general, wherever possible a lower current limit is recommended due to allowing system advantages through:

- Reduced size and cost in current carrying components such as PCB traces and module connectors
- Less disturbance at the power supply ( $V_{BB}$  pin) during a short circuit event
- Improved protection of the downstream load

To set the current limit threshold, connect a resistor from  $I_{LIM}$  to  $V_{BB}$ . The current limit threshold is determined by [Equation 1](#) ( $R_{ILIM}$  in k $\Omega$ ):

$$I_{CL} = K_{CL} / R_{ILIM} \quad (1)$$

The  $R_{ILIM}$  range is between 5 k $\Omega$  and 25 k $\Omega$ . An  $R_{ILIM}$  resistor is required, however in the fault case where the pin is floating, grounded, or outside of this range the current limit will default to an internal level that is defined in the [Specifications](#) section of this document. If  $R_{ILIM}$  is out of this range, the device cannot guarantee complete short-circuit protection.

#### 注

Capacitance on the  $I_{LIM}$  pin can cause  $I_{LIM}$  to go out of range during short circuit events. For accurate current limiting, place  $R_{ILIM}$  near to the device with short traces to ensure <5 pF capacitance to GND on the  $I_{LIM}$  pin.

## Feature Description (接下页)

### 9.3.1.2.3 Undervoltage Lockout (UVLO)

The device monitors the supply voltage  $V_{BB}$  to prevent unpredicted behaviors in the event that the supply voltage is too low. When the supply voltage falls down to  $V_{UVLOF}$ , the output stage is shut down automatically. When the supply rises up to  $V_{UVLOR}$ , the device turns back on.

During an initial ramp of  $V_{BB}$  from 0 V at a ramp rate slower than 1 V/ms,  $V_{EN}$  pin will have to be held low until  $V_{BB}$  is above UVLO threshold (with respect to board ground) and the supply voltage to the device has reliably reached above the UVLO condition. For best operation, ensure that  $V_{BB}$  has risen above UVLO before setting the  $V_{EN}$  pin to high.

### 9.3.1.2.4 $V_{BB}$ During Short-to-Ground

When  $V_{OUT}$  is shorted to ground, the module power supply ( $V_{BB}$ ) can have a transient decrease. This is caused by the sudden increase in current flowing through the wiring harness cables. To achieve ideal system behavior, it is recommended that the module maintain  $V_{BB} > 3$  V (above the maximum  $V_{UVLOF}$ ) during  $V_{OUT}$  short-to-ground. This is typically accomplished by placing bulk capacitance on the power supply node.

### 9.3.1.3 Voltage Transients

The TPS1HB16-Q1 device contains two types of voltage clamps which protect the FET against system-level voltage transients. The two different clamps are shown in 图 5.

The clamp from  $V_{BB}$  to GND is primarily used to protect the controller from positive transients on the supply line (for example, ISO7637-2). The clamp from  $V_{BB}$  to  $V_{OUT}$  is primarily used to limit the voltage across the FET when switching off an inductive load. If the voltage potential from  $V_{BB}$  to GND exceeds the  $V_{BB}$  clamp level, the clamp will allow current to flow through the device from  $V_{BB}$  to GND (Path 2). If the voltage potential from  $V_{BB}$  to  $V_{OUT}$  exceeds the clamping voltage, the power FET will allow current to flow from  $V_{BB}$  to  $V_{OUT}$  (Path 3). Additional capacitance from  $V_{BB}$  to GND can increase the reliability of the system during ISO 7637 pulse 2 A testing.



图 5. Current Path During Supply Voltage Transient

### 9.3.1.3.1 Load Dump

The TPS1HB16-Q1 device is tested according to ISO 16750-2:2010(E) suppressed load dump pulse. The device supports up to 40-V load dump transient and will maintain normal operation during the load dump pulse. If the switch is enabled, it will stay enabled and if the switch is disabled, it will stay disabled.

## Feature Description (接下页)

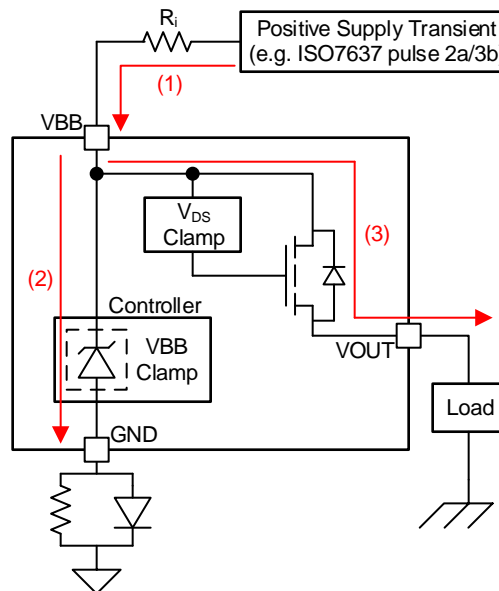
### 9.3.1.3.2 Driving Inductive Loads

When switching off an inductive load, the inductor may impose a negative voltage on the output of the switch. The TPS1HB16-Q1 includes a voltage clamp to limit voltage across the FET. The maximum acceptable load inductance is a function of the device robustness.

For more information on driving inductive loads, refer to TI's [How To Drive Inductive, Capacitive, and Lighting Loads With Smart High Side Switches](#) application report.

### 9.3.1.4 Reverse Battery

In the reverse battery condition, the switch will automatically be enabled regardless of the state of EN to prevent excess power dissipation inside the MOSFET body diode. In many applications (for example, resistive loads), the full load current may be present during reverse battery. In order to activate the automatic switch on feature, all NC pins must be grounded to IC ground.

There are two options for blocking reverse current in the system. The first option is to place a blocking device (FET or diode) in series with the battery supply, blocking all current paths. The second option is to place a blocking diode in series with the GND node of the high-side switch. This method will protect the controller portion of the switch (path 2), but it will not prevent current from flowing through the load (path 3). The diode used for the second option may be shared amongst multiple high-side switches.

Path 1 shown in [图 6](#) is blocked inside of the device.



图 6. Current Path During Reverse Battery

For more information on reverse battery protection, refer to TI's [Reverse Battery Protection for High Side Switches](#) application note.

Feature Description (接下页)

9.3.1.5 Fault Event – Timing Diagrams

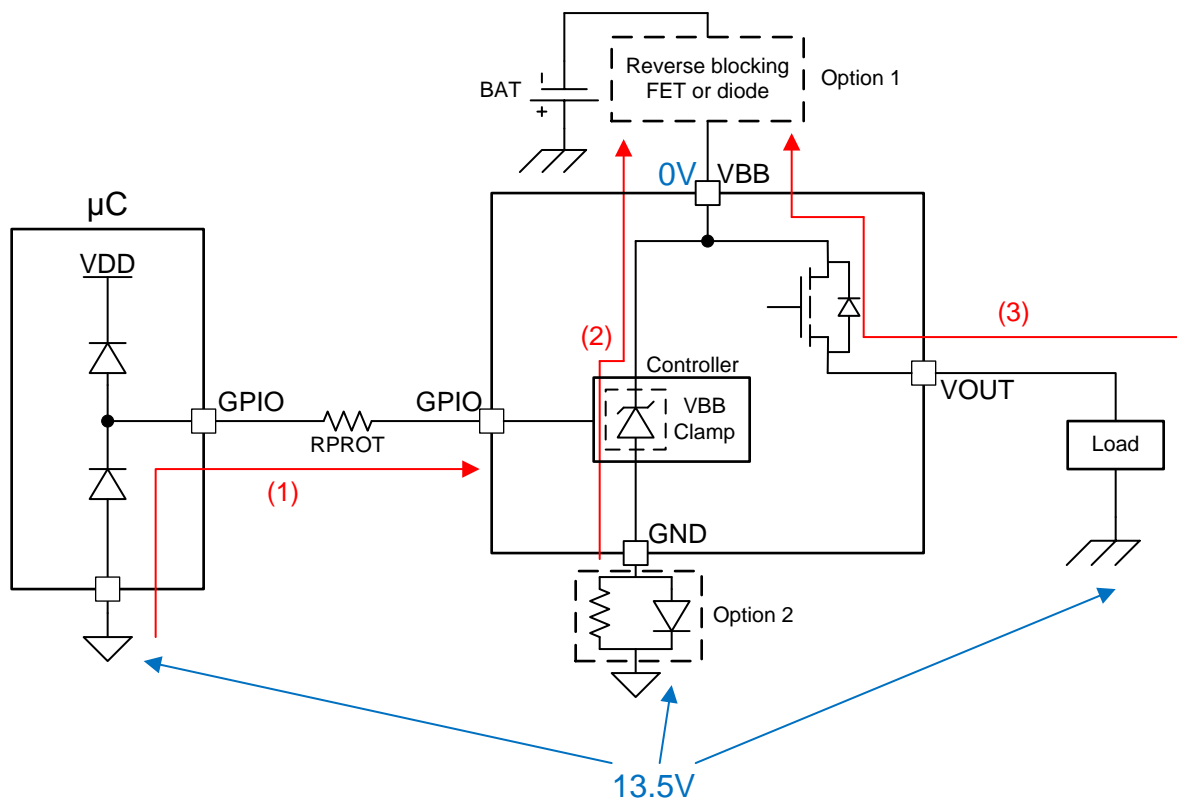
注

All timing diagrams assume that the SEL1 pin is low.

The LATCH, DIA\_EN, and EN pins are controlled by the user. The timing diagrams represent a possible use-case.

图 7 shows the immediate current limit switch off behavior. The diagram also illustrates the retry behavior. As shown, the switch will remain latched off until the LATCH pin is low.



图 7. Current Limit – Version A and B - Latched Behavior

ADVANCE INFORMATION

**Feature Description (接下页)**

图 8 显示了立即电流限制开关关闭行为。在此示例中，LATCH 连接到 GND；因此，清除故障后，开关将在  $t_{RETRY}$  过期后重试。

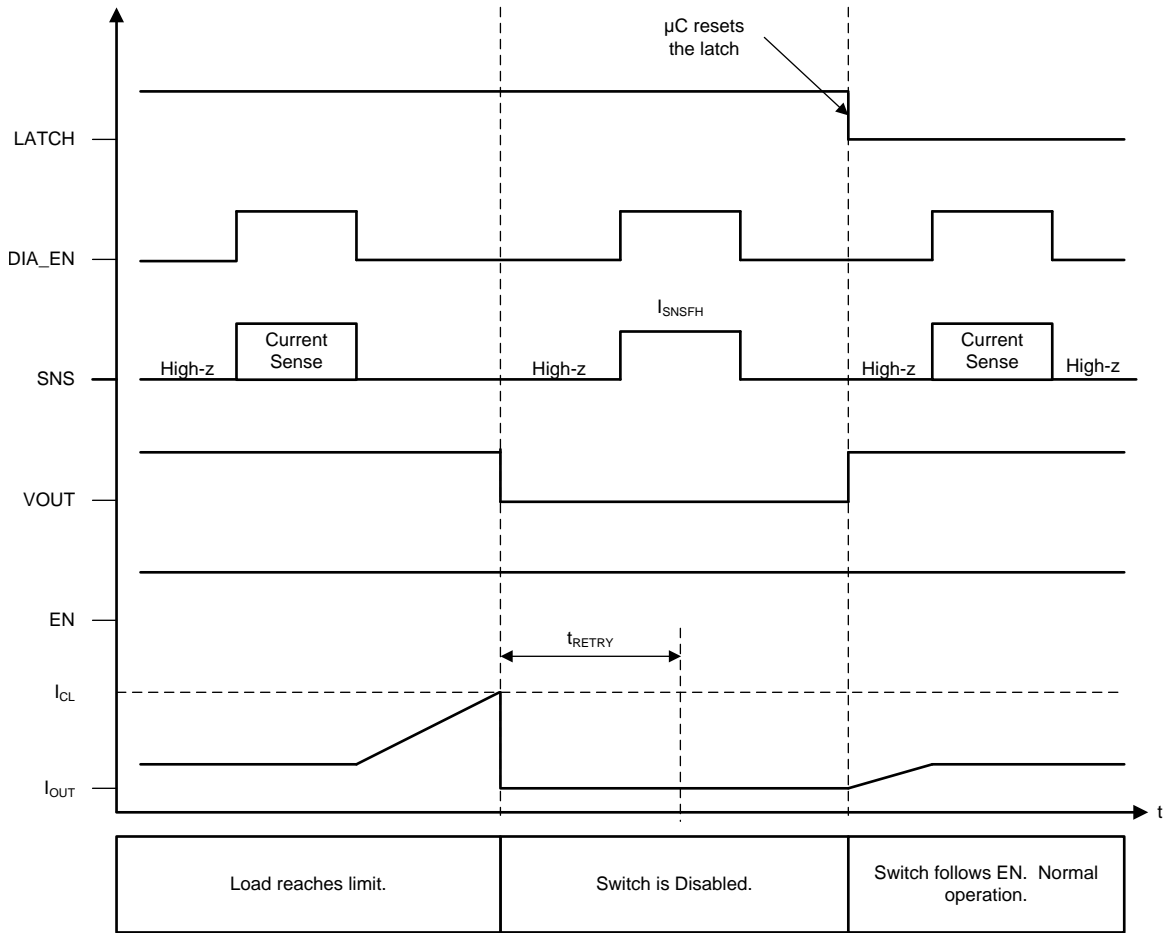
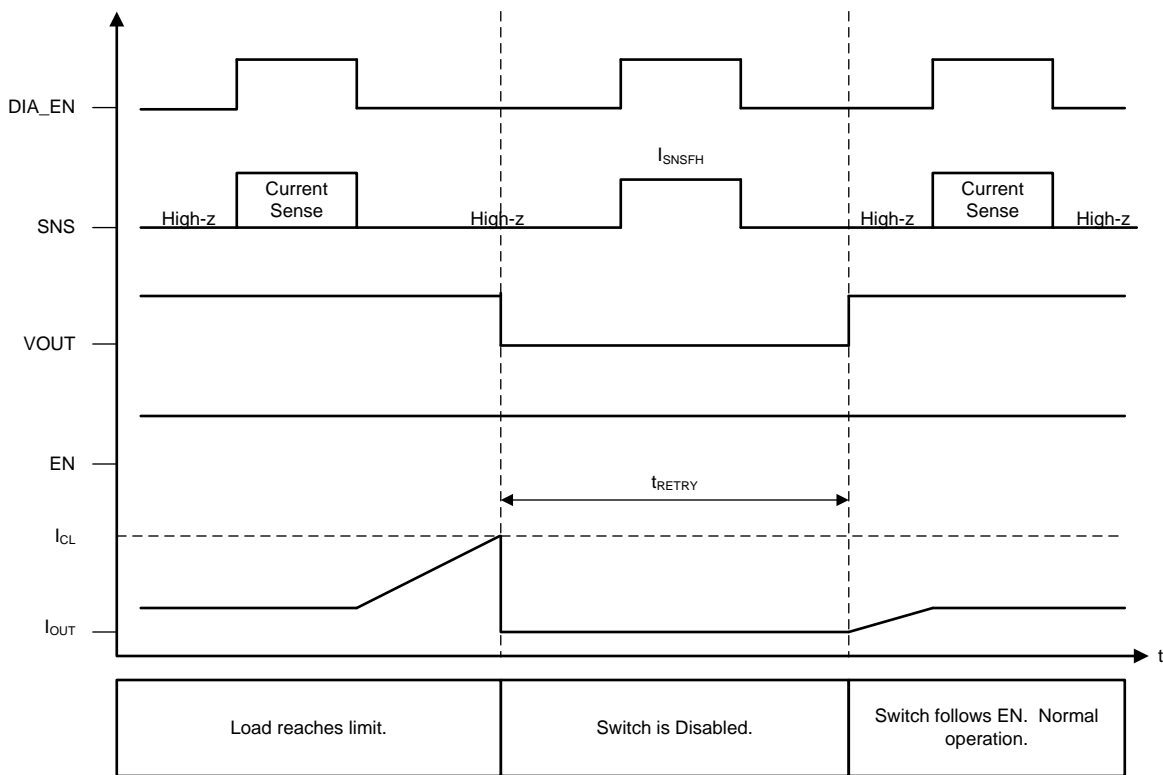

**图 8. Current Limit - Version A and B - LATCH = 0**

当开关在 shutdown 事件后重试时，SNS 故障指示将保持，直到  $V_{OUT}$  上升到  $V_{BB} - 1.8\text{ V}$ 。一旦  $V_{OUT}$  上升，SNS 故障指示重置，电流检测可用。如果发生短路到地且  $V_{OUT}$  无法上升，SNS 故障指示将无限期保持。图 9 说明了自动重试行为，并提供了故障指示期间重试的放大视图。

**注**

图 9 假设  $t_{RETRY}$  在  $T_J$  达到迟滞阈值之前已过期。

LATCH = 0 V 和 DIA\_EN = 5 V

## Feature Description (接下页)



图 9. Fault Indication During Retry

### 9.3.2 Diagnostic Mechanisms

#### 9.3.2.1 VOUT Short-to-Battery and Open-Load

The TPS1HB16-Q1 is capable of detecting short-to-battery and open-load events regardless of whether the switch is turned on or off, however the two conditions use different methods.

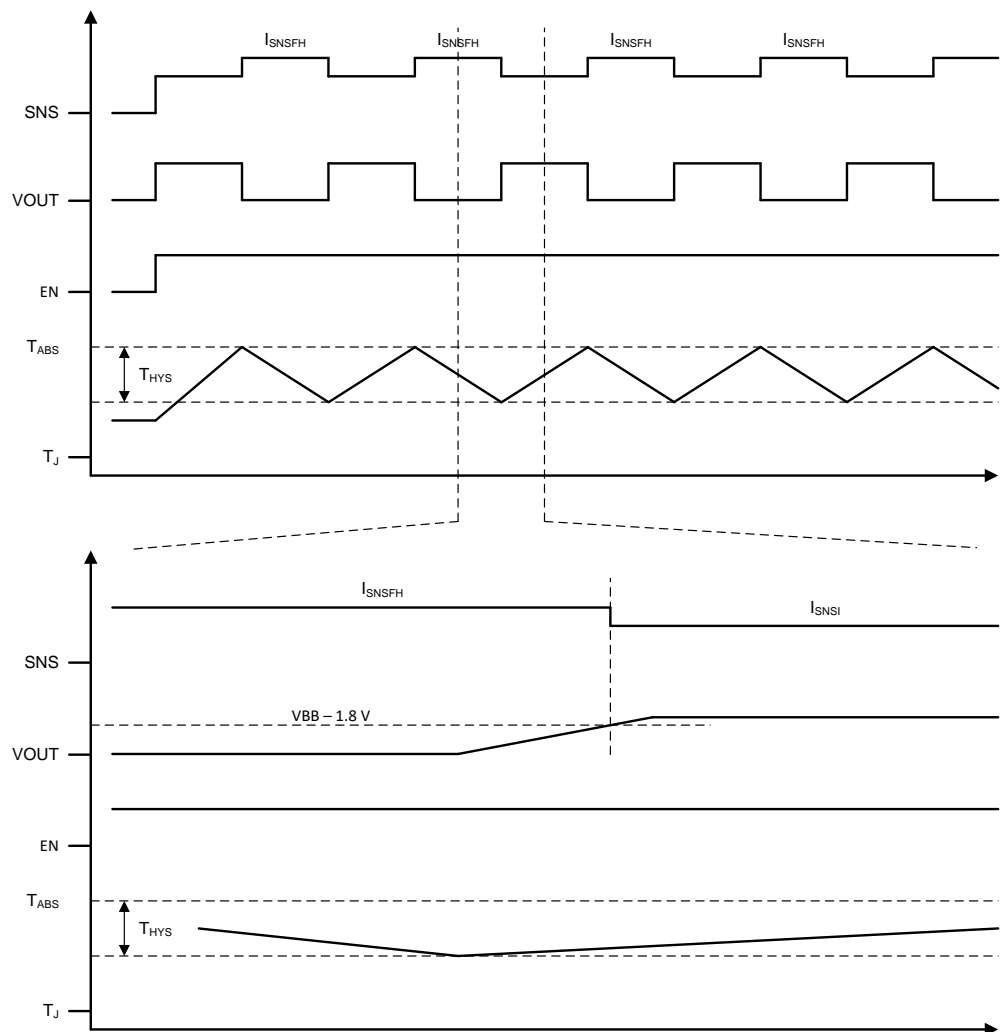
##### 9.3.2.1.1 Detection With Switch Enabled

When the switch is enabled, the VOUT short-to-battery and open-load conditions can be detected by the current sense feature. In both cases, the load current will be measured through the SNS pin as below the expected value.

**Feature Description (接下页)**
**9.3.2.1.2 Detection With Switch Disabled**

While the switch is disabled, if DIA\_EN is high, an internal comparator will detect the condition of  $V_{OUT}$ . If the load is disconnected (open load condition) or there is a short to battery the  $V_{OUT}$  voltage will be higher than the open load threshold ( $V_{OL,off}$ ) and a fault is indicated on the SNS pin. An internal pull-up of  $1\text{ M}\Omega$  is in series with an internal MOSFET switch, so no external component is required if a completely open load must be detected. However, if there is significant leakage or other current draw even when the load is disconnected, a lower value pull-up resistor and switch can be added externally to set the  $V_{OUT}$  voltage above the  $V_{OL,off}$  during open load conditions.

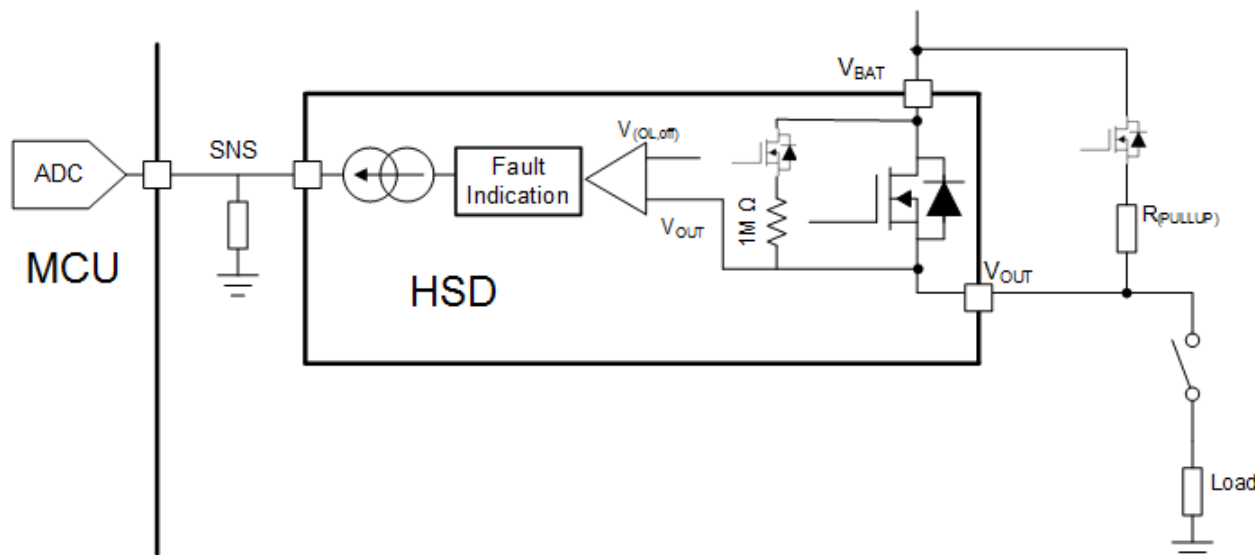

- (1) This figure assumes that the device ground and the load ground are at the same potential. In a real system, there may be a ground shift voltage of 1 V to 2 V.

**图 10. Short to Battery and Open Load Detection**

The detection circuitry is only enabled when DIA\_EN = HIGH and EN = LOW. If  $V_{OUT} > V_{OL}$ , the SNS pin will go to the fault level, but if  $V_{OUT} < V_{OL}$  there will be no fault indication. The fault indication will only occur if the SEL1 pin is low.

While the switch is disabled and DIA\_EN is high, the fault indication mechanisms will continuously represent the present status. For example, if  $V_{OUT}$  decreases from greater than  $V_{OL}$  to less than  $V_{OL}$ , the fault indication is reset. Additionally, the fault indication is reset upon the falling edge of DIA\_EN or the rising edge of EN.

Feature Description (接下页)



图 11. Open Load

9.3.2.2 SNS Output

The SNS output may be used to sense the load current if the SEL1 pin is low and there is no fault or device temperature if the SEL1 pin is high and there is no fault. The sense circuit will provide a current that is proportional to the selected parameter. This current will be sourced into an external resistor to create a voltage that is proportional to the selected parameter. This voltage may be measured by an ADC or comparator. In addition, the SNS pin can be used to measure the FET temperature.

To ensure accurate sensing measurement, the sensing resistor should be connected to the same ground potential as the  $\mu$ C ADC.

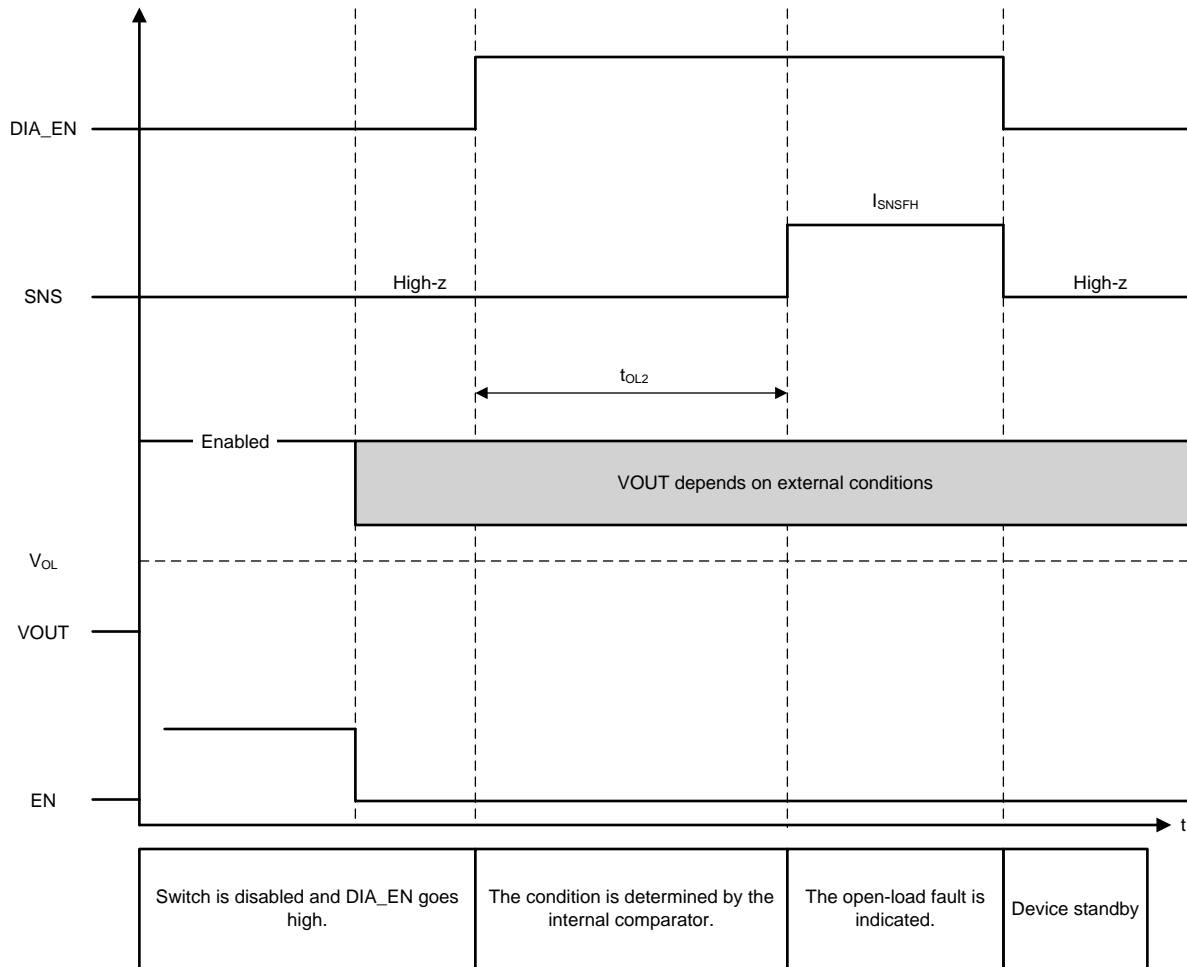
表 3. Analog Sense Transfer Function

PARAMETER	TRANSFER FUNCTION
Load current	$I_{SNSI} = I_{OUT} / K_{SNS} = I_{OUT} / 3000$
Device temperature	$I_{SNST} = (T_J - 25^\circ\text{C}) \times dI_{SNST} / dT + 0.85$

The SNS output will also be used to indicate system faults.  $I_{SNS}$  will go to the predefined level,  $I_{SNSFH}$ , when there is a fault.  $I_{SNSFH}$ ,  $dI_{SNST}/dT$ , and  $K_{SNS}$  are defined in the [Specifications](#) section.

9.3.2.2.1 R<sub>SNS</sub> Value

The following factors should be considered when selecting the R<sub>SNS</sub> value:

- Current sense ratio ( $K_{SNS}$ )
- Largest and smallest diagnosable load current required for application operation
- Full-scale voltage of the ADC
- Resolution of the ADC

For an example of selecting  $R_{ISNS}$  value, reference [R<sub>ILIM</sub> Calculation](#) in the applications section of this datasheet.

#### 9.3.2.2.1.1 High Accuracy Load Current Sense

In many automotive modules, it is required that the high-side switch provide diagnostic information about the downstream load. With more complex loads, high accuracy sensing is required. A few examples follow:

- **LED lighting:** In many architectures, the body control module (BCM) must be compatible with both incandescent bulbs and also LED modules. The bulb may be relatively simple to diagnose. However, the LED module will consume less current and also can include multiple LED strings in parallel. The same BCM is used in both cases, so the high-side switch can accurately diagnose both load types.
- **Solenoid protection:** Often solenoids are precisely controlled by low-side switches. However, in a fault event, the low-side switch cannot disconnect the solenoid from the power supply. A high-side switch can be used to continuously monitor several solenoids. If the system current becomes higher than expected, the high-side switch can disable the module.

#### 9.3.2.2.1.2 SNS Output Filter

To achieve the most accurate current sense value, it is recommended to filter the SNS output. There are two methods of filtering:

- Low-Pass RC filter between the SNS pin and the ADC input. This filter is illustrated in [图 15](#) with typical values for the resistor and capacitor. The designer should select a  $C_{SNS}$  capacitor value based on system requirements. A larger value will provide improved filtering but a smaller value will allow for faster transient response.
- The ADC and microcontroller can also be used for filtering. It is recommended that the ADC collects several measurements of the SNS output. The median value of this data set should be considered as the most accurate result. By performing this median calculation, the microcontroller can filter out any noise or outlier data.

#### 9.3.2.3 Fault Indication and SNS Mux

The following faults will be communicated through the SNS output:

- Switch shutdown, due to:
  - Thermal Shutdown
  - Current limit
- Open-Load and  $V_{OUT}$  shorted-to-battery

Open-load and Short-to-battery are not indicated while the switch is enabled, although these conditions can still be detected through the sense current. Hence, if there is a fault indication while the channel is enabled, then it must be either due to an overcurrent or overtemperature event.

The SNS pin will only indicate the fault if the SEL1 pins is low. When the SEL1 pin is high and the device is set to measure temperature, the pin will be measuring the channel FET temperature.

**表 4. Device Version A/B SNS Mux**

INPUTS			OUTPUTS
DIA_EN	SEL1	FAULT DETECT <sup>(1)</sup>	SNS
0	X	X	High-z
1	0	0	Output current
1	1	0	Device temperature
1	0	1	I <sub>SNSFH</sub>

(1) Fault Detect encompasses multiple conditions:  
 (a) Switch shutdown and waiting for retry  
 (b) Open Load and Short To Battery

表 4. Device Version A/B SNS Mux (接下页)

DIA_EN	INPUTS		OUTPUTS
	SEL1	FAULT DETECT <sup>(1)</sup>	SNS
1	1	1	Device temperature

### 9.3.2.4 Resistor Sharing

Multiple high-side devices may use the same SNS resistor as shown in 图 12. This reduces the total number of passive components in the system and the number of ADC terminals that are required of the microcontroller.



图 12. Sharing  $R_{SNS}$  Among Multiple Devices

### 9.3.2.5 High-Frequency, Low Duty-Cycle Current Sensing

Some applications will operate with a high-frequency, low duty-cycle PWM or require fast settling of the SNS output. For example, a 250 Hz, 5% duty cycle PWM will have an on-time of only 200  $\mu$ s that must be accommodated. The micro-controller ADC may sample the SNS signal after the defined settling time  $t_{SNSION3}$ .

**图 13. Current Sensing in Low-Duty Cycle Applications**

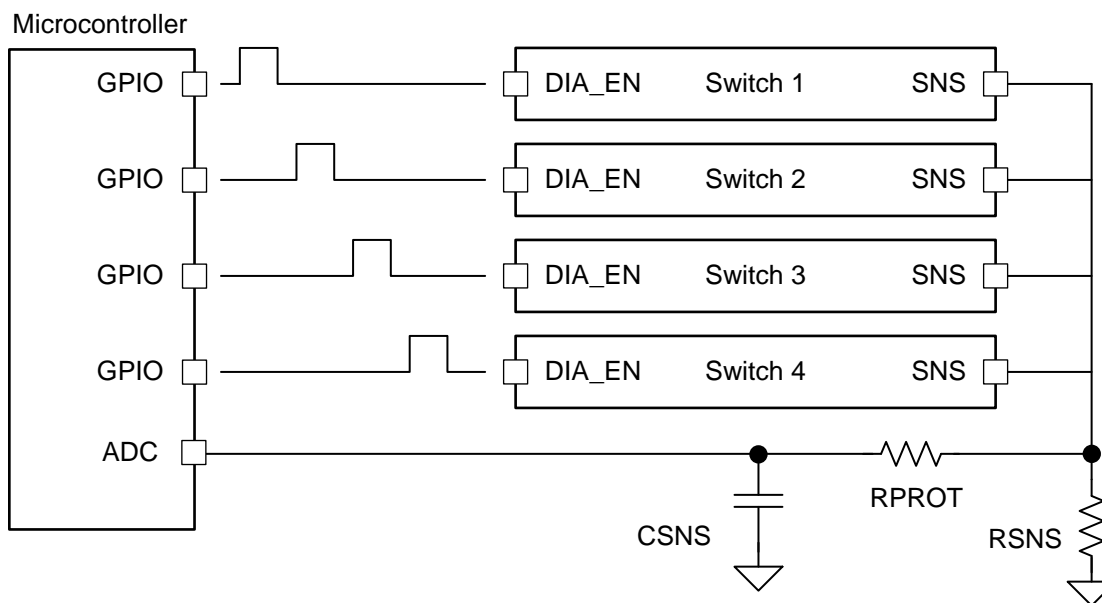
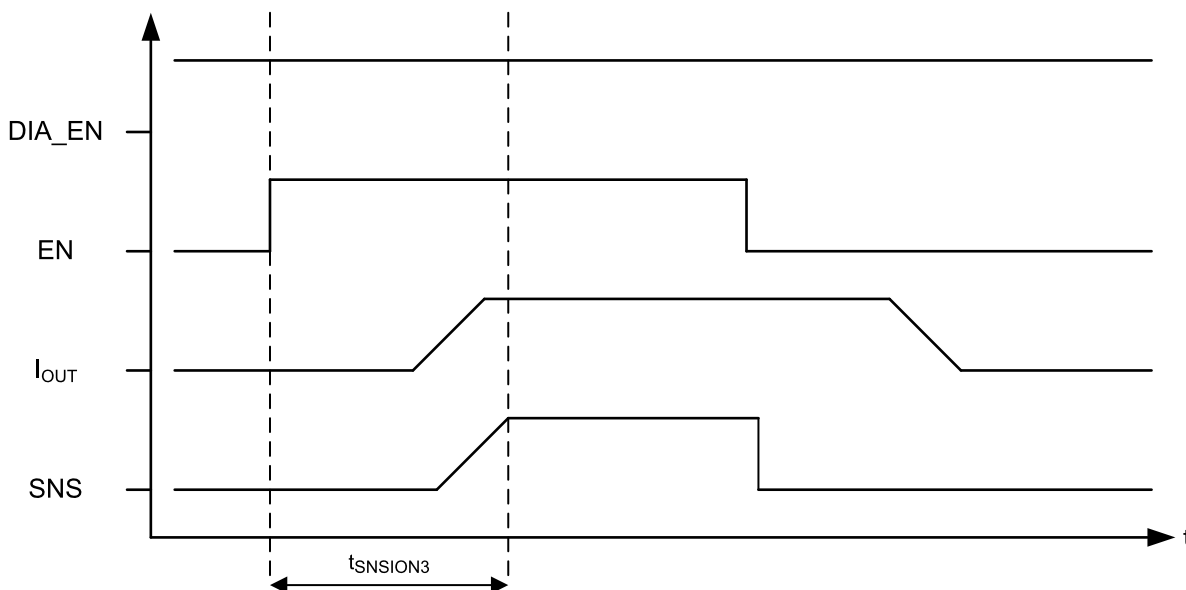
## 9.4 Device Functional Modes

During typical operation, the TPS1HB16-Q1 can operate in a number of states that are described below and shown as a state diagram in [图 14](#).

### 9.4.1 Off

Off state occurs when the device is not powered.

### 9.4.2 Standby

Standby state is a low-power mode used to reduce power consumption to the lowest level. Diagnostic capabilities are not available in Standby mode.

### 9.4.3 Diagnostic

Diagnostic state may be used to perform diagnostics while the switch is disabled.

### 9.4.4 Standby Delay

The Standby Delay state is entered when EN and DIA\_EN are low. After  $t_{STBY}$ , if the EN and DIA\_EN pins are still low, the device will go to Standby State.

### 9.4.5 Active

In Active state, the switch is enabled. The diagnostic functions may be turned on or off during Active state.

### 9.4.6 Fault

The Fault state is entered if a fault shutdown occurs (thermal shutdown or current limit). After all faults are cleared, the LATCH pin is low, and the retry timer has expired, the device will transition out of Fault state. If the EN pin is high, the switch will re-enable. If the EN pin is low, the switch will remain off.

Device Functional Modes (接下页)



图 14. State Diagram

ADVANCE INFORMATION

## 10 Application and Implementation

注

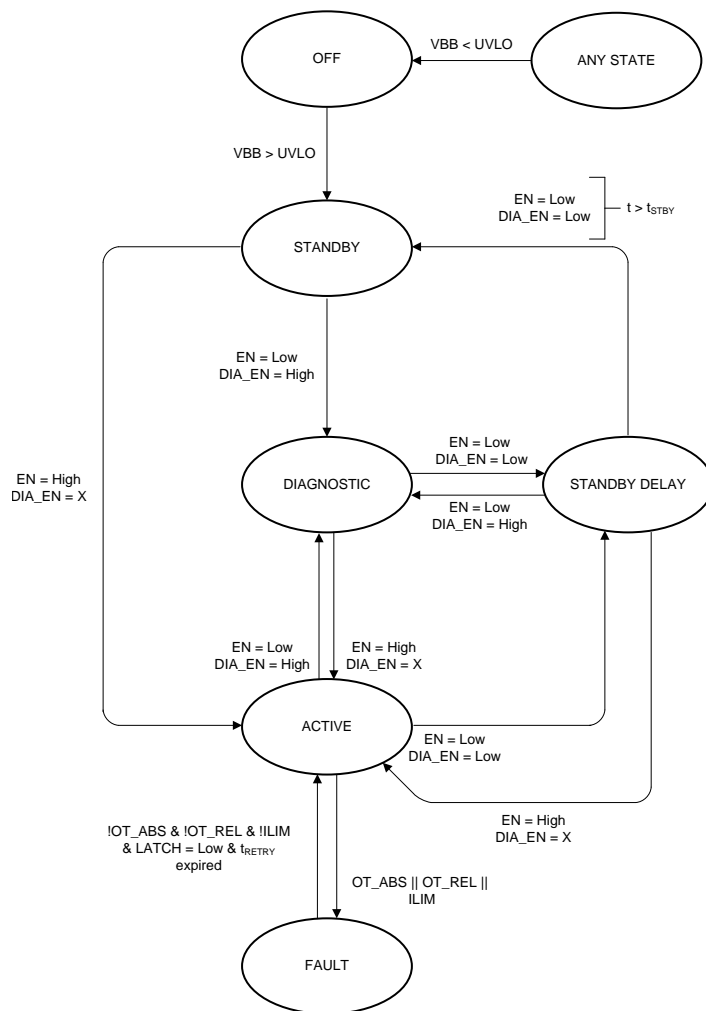
Information in the following applications sections is not part of the TI component specification, and TI does not warrant its accuracy or completeness. TI's customers are responsible for determining suitability of components for their purposes. Customers should validate and test their design implementation to confirm system functionality.

### 10.1 Application Information

图 15 shows the schematic of a typical application for version A or B of the TPS1HB16-Q1. It includes all standard external components. This section of the datasheet discusses the considerations in implementing commonly required application functionality.

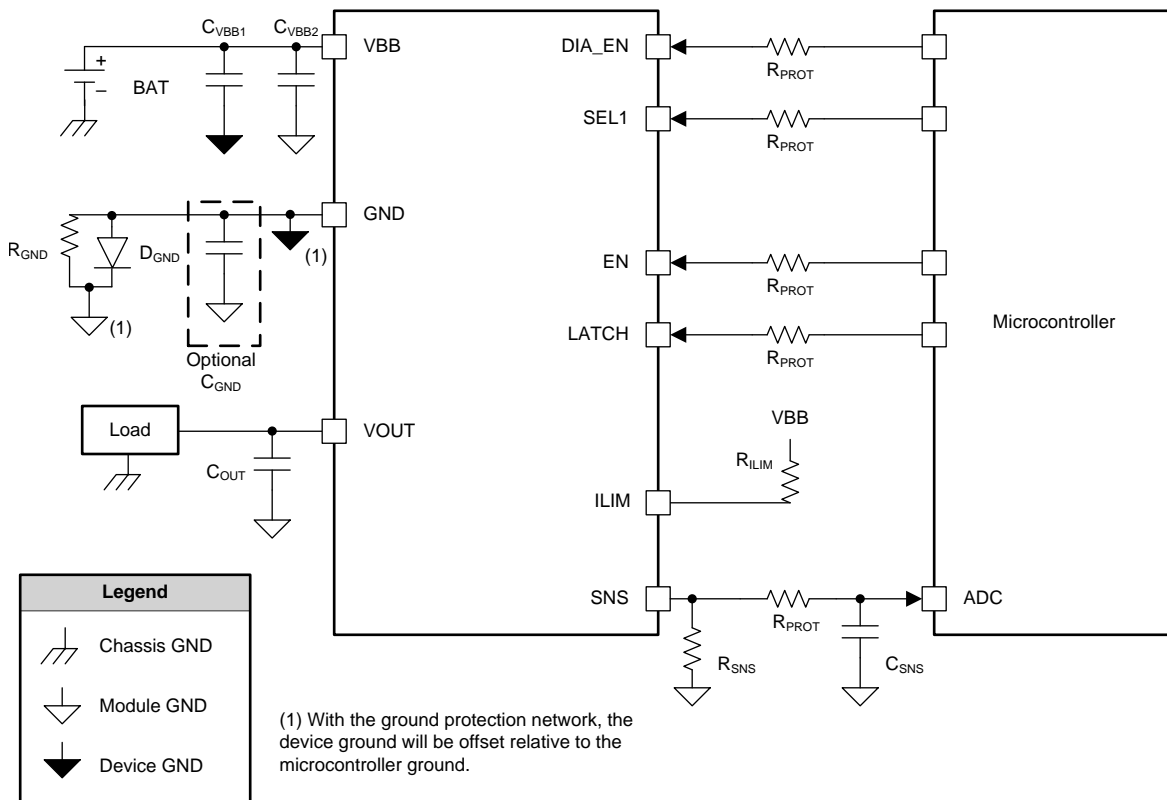

(1) With the ground protection network, the device ground will be offset relative to the microcontroller ground.

图 15. System Diagram

表 5. Recommended External Components

COMPONENT	TYPICAL VALUE	PURPOSE
$R_{PROT}$	15 k $\Omega$	Protect microcontroller and device I/O pins
$R_{SNS}$	1 k $\Omega$	Translate the sense current into sense voltage
$C_{SNS}$	100 pF - 10 nF	Low-pass filter for the ADC input
$R_{GND}$	4.7 k $\Omega$	Stabilize GND potential during turn-off of inductive load
$D_{GND}$	BAS21 Diode	Protects device during reverse battery
$R_{ILIM}$	5 k $\Omega$ - 25 k $\Omega$	Set current limit threshold
$C_{VBB1}$	220 nF to Device GND	Filtering of voltage transients (for example, ESD, ISO7637-2) and improved emissions
$C_{VBB2}$	100 nF to Module GND	Stabilize the input supply and filter out low frequency noise.

## Application Information (接下页)

**表 5. Recommended External Components (接下页)**

COMPONENT	TYPICAL VALUE	PURPOSE
C <sub>OUT</sub>	47 nF	Filtering of voltage transients (for example, ESD, ISO7637-2)
C <sub>GND</sub>	1 μF from Device GND to Module GND	Optional capacitance to help with RF immunity.

### 10.1.1 Ground Protection Network

As discussed in the [Reverse Battery](#) section, D<sub>GND</sub> may be used to prevent excessive reverse current from flowing into the device during a reverse battery event. Additionally, R<sub>GND</sub> is placed in parallel with D<sub>GND</sub> if the switch is used to drive an inductive load. The ground protection network (D<sub>GND</sub> and R<sub>GND</sub>) may be shared amongst multiple high-side switches.

A minimum value for R<sub>GND</sub> may be calculated by using the absolute maximum rating for I<sub>GND</sub>. During the reverse battery condition,  $I_{GND} = V_{BB} / R_{GND}$ :

$$R_{GND} \geq V_{BB} / I_{GND}$$

- Set  $V_{BB} = -13.5 \text{ V}$
- Set  $I_{GND} = -50 \text{ mA}$  (absolute maximum rating)

$$R_{GND} \geq -13.5 \text{ V} / -50 \text{ mA} = 270 \ \Omega \quad (2)$$

In this example, it is found that R<sub>GND</sub> must be at least 270 Ω. It is also necessary to consider the power dissipation in R<sub>GND</sub> during the reverse battery event:

$$P_{RGND} = V_{BB}^2 / R_{GND} \quad (3)$$

$$P_{RGND} = (13.5 \text{ V})^2 / 270 \ \Omega = 0.675 \text{ W}$$

In practice, R<sub>GND</sub> may not be rated for such a high power. In this case, a larger resistor value should be selected.

### 10.1.2 Interface With Microcontroller

The ground protection network will cause the device ground to be at a higher potential than the module ground (and microcontroller ground). This offset will impact the interface between the device and the microcontroller.

Logic pin voltage will be offset by the forward voltage of the diode. For input pins (for example, EN), the designer must consider the V<sub>IH</sub> specification of the switch and the V<sub>OH</sub> specification of the microcontroller. For a system that *does not* include D<sub>GND</sub>, it is required that V<sub>OH</sub> > V<sub>IH</sub>. For a system that *does* include D<sub>GND</sub>, it is required that V<sub>OH</sub> > (V<sub>IH</sub> + V<sub>F</sub>). V<sub>F</sub> is the forward voltage of D<sub>GND</sub>.

The sense resistor, R<sub>SNS</sub>, should be terminated to the microcontroller ground. In this case, the ADC can accurately measure the SNS signal even if there is an offset between the microcontroller ground and the device ground.

### 10.1.3 I/O Protection

R<sub>PROT</sub> is used to protect the microcontroller I/O pins during system-level voltage transients such as ISO pulses or reverse battery. The SNS pin voltage can exceed the ADC input pin maximum voltage if the fault or saturation current causes a high enough voltage drop across the sense resistor. If that can occur in the design (for example, by switching to a high value R<sub>SNS</sub> to improve ADC input level), then an appropriate external clamp has to be designed to prevent a high voltage at the SNS output and the ADC input.

### 10.1.4 Inverse Current

Inverse current occurs when  $0 \text{ V} < V_{BB} < V_{OUT}$ . In this case, current may flow from V<sub>OUT</sub> to V<sub>BB</sub>. Inverse current cannot be caused by a purely resistive load. However, a capacitive or inductive load can cause inverse current. For example, if there is a significant amount of load capacitance and the V<sub>BB</sub> node has a transient droop, V<sub>OUT</sub> may be greater than V<sub>BB</sub>.

The TPS1HB16-Q1 will not detect inverse current. When the switch is enabled, inverse current will pass through the switch. When the switch is disabled, inverse current may pass through the MOSFET body diode. The device will continue operating in the normal manner during an inverse current event.

### 10.1.5 Loss of GND

The ground connection may be lost either on the device level or on the module level. If the ground connection is lost, the switch will be disabled. If the switch was already disabled when the ground connection was lost, the switch will remain disabled. When the ground is reconnected, normal operation will resume.

### 10.1.6 Automotive Standards

The TPS1HB16-Q1 is designed to be protected against all relevant automotive standards to ensure reliable operations when connected to a 12-V automotive battery.

#### 10.1.6.1 ISO7637-2

The TPS1HB16-Q1 is tested according to the ISO7637-2:2011 (E) standard. The test pulses are applied both with the switch enabled and disabled. The test setup includes only the DUT and minimal external components:  $C_{VBB}$ ,  $C_{OUT}$ ,  $D_{GND}$ , and  $R_{GND}$ .

Status II is defined in ISO 7637-1 Function Performance Status Classification (FPSC) as: “The function does not perform as designed during the test but returns automatically to normal operation after the test”. See 表 6 for ISO7637-2:2011 (E) expected results.

表 6. ISO7637-2:2011 (E) Results

TEST PULSE	TEST PULSE SEVERITY LEVEL WITH STATUS II FUNCTIONAL PERFORMANCE		MINIMUM NUMBER OF PULSES OR TEST TIME	BURST CYCLE / PULSE REPETITION TIME	
	LEVEL	US		MIN	MAX
1	III	-112 V	500 pulses	0.5 s	--
2a <sup>(1)</sup>	III	+55 V	500 pulses	0.20	5 s
2b	IV	+10 V	10 pulses	0.5 s	5 s
3a	IV	-220 V	1 hour	90 ms	100 ms
3b	IV	+150 V	1 hour	90 ms	100 ms

(1) 1  $\mu$ F capacitance on  $C_{VBB}$  is required for passing level 3 ISO7637 pulse 2 A.

#### 10.1.6.2 AEC-Q100-012 Short Circuit Reliability

The TPS1HB16-Q1 is tested according to the AEC-Q100-012 Short Circuit Reliability standard. This test is performed to demonstrate the robustness of the device against  $V_{OUT}$  short-to-ground events. Test conditions and test procedures are summarized in 表 7. For further details, refer to the AEC-Q100-012 standard document.

Test conditions:

- LATCH = 0 V
- $I_{LIM}$  = Open
- 10 units from 3 separate lots for a total of 30 units.
- $L_{supply}$  = 5  $\mu$ H,  $R_{supply}$  = 10 m $\Omega$
- $V_{BB}$  = 14 V

Test procedure:

- Parametric data is collected on each unit pre-stress
- Each unit is enabled into a short-circuit with the required short circuit cycles or duration as specified
- Functional testing is performed on each unit post-stress to verify that the part still operates as expected

The cold repetitive test is run at 85°C which is the worst case condition for the device to sustain a short circuit. The cold repetitive test refers to the device being given time to cool down between pulses, rather than being run at a cold temperature. The load short circuit is the worst case situation, since the energy stored in the cable inductance can cause additional harm. The fast response of the device ensures current limiting occurs quickly and at a current close to the load short condition. In addition, the hot repetitive test is performed as well.

表 7. AEC-Q100-012 Test Results

TEST	LOCATION OF SHORT	DEVICE VERSION	NO. OF CYCLES / DURATION	NO. OF UNITS	NO. OF FAILS
Cold Repetitive - Long Pulse <sup>(1)</sup>	Load Short Circuit, $L_{short} = 5 \mu H$ , $R_{short} = 200 m\Omega$ , $T_A = 85^\circ C$	B	100 k cycles	30	0
Hot Repetitive - Long Pulse	Load Short Circuit, $L_{short} = 5 \mu H$ , $R_{short} = 100 m\Omega$ , $T_A = 25^\circ C$	B	100 hours	30	0

(1) For Cold Repetitive short, 200 mΩ  $R_{short}$  is used so that the device is at a higher junction temperature before the short circuit event, increasing the harshness of the test.

### 10.1.7 Thermal Information

When outputting current, the TPS1HB16-Q1 will heat up due to the power dissipation. The transient thermal impedance curve can be used to determine the device temperature during a pulse of a given length. This  $Z_{\theta JA}$  value corresponds to a JEDEC standard 2s2p thermal test PCB with thermal vias.



图 16. TPS1HB16-Q1 Transient Thermal Impedance

### 10.2 Typical Application

This application example demonstrates how the TPS1HB16-Q1 device can be used to power resistive heater loads in automotive seats. In this example, we consider a heater load that is powered by the device. This is just one example of the many applications where this device can fit.

ADVANCE INFORMATION

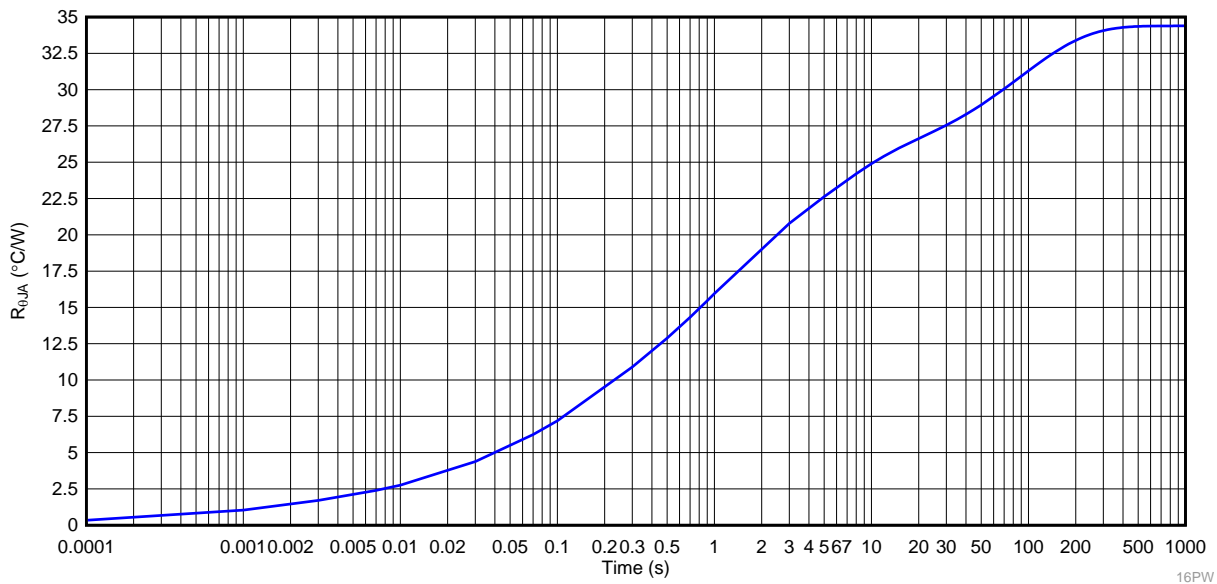
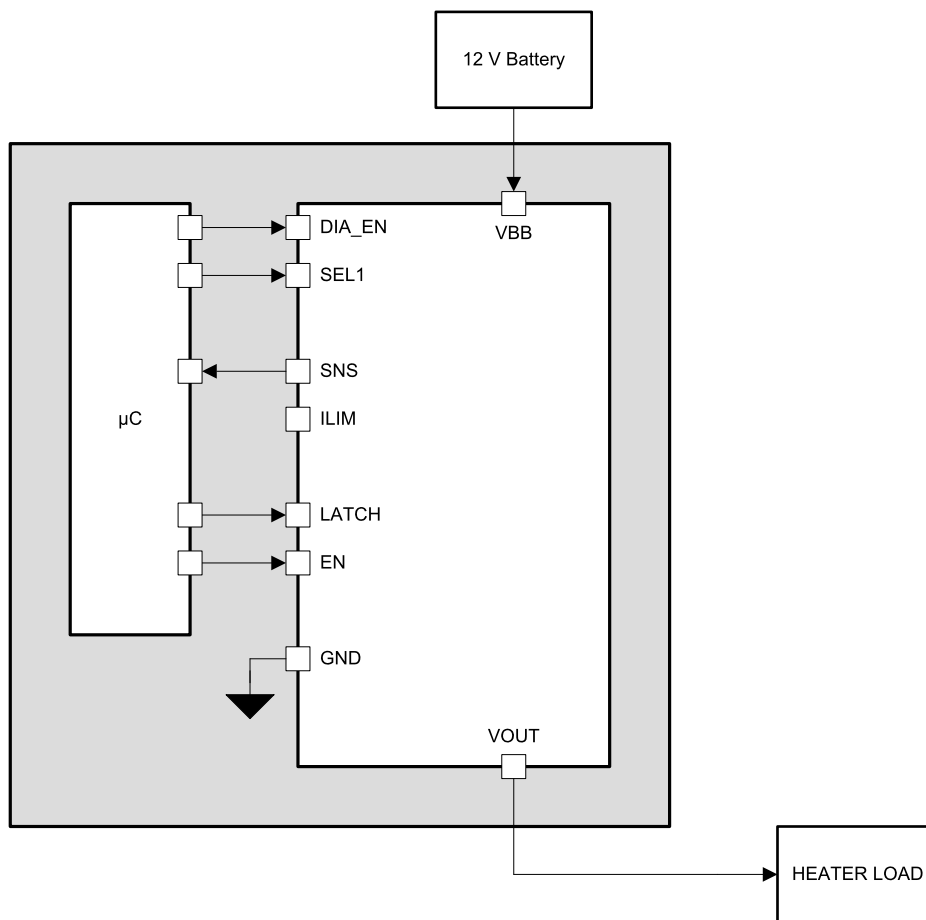
**Typical Application (接下页)**

**图 17. Block Diagram for Powering Heater Load**
**10.2.1 Design Requirements**

For this design example, use the input parameters shown in 表 8.

**表 8. Design Parameters**

DESIGN PARAMETER	EXAMPLE VALUE
$V_{BB}$	13.5 V
Load - Heater	80 W max
Load Current Sense	60 mA to 12 A
$I_{LIM}$	8 A
Ambient temperature	70°C
$R_{\theta JA}$	34.3°C/W (depending on PCB)
Device Version	A

**10.2.2 Detailed Design Procedure**
**10.2.2.1 Thermal Considerations**

The 80 W heater load will cause a DC current in the channel under maximum load power condition of around 5.9 A. Therefore, this current at 13.5 V will assume worst case heating.

Power dissipation in the switch is calculated in 公式 4.  $R_{ON}$  is assumed to be 32 mΩ because this is the maximum specification at high temperature. In practice,  $R_{ON}$  will almost always be lower.

$$P_{FET} = I^2 \times R_{ON} \quad (4)$$

$$P_{FET} = (5.9 \text{ A})^2 \times 32 \text{ m}\Omega = 1.11 \text{ W} \quad (5)$$

This means that the maximum FET power dissipation is 1.11 W. The junction temperature of the device can be calculated using [公式 6](#) and the  $R_{\theta JA}$  value from the [Specifications](#) section.

$$T_J = T_A + R_{\theta JA} \times P_{FET} \quad (6)$$

$$T_J = 70^\circ\text{C} + 34.3^\circ\text{C/W} \times 1.11 \text{ W} = 108.1^\circ\text{C}$$

The maximum junction temperature rating for the TPS1HB16-Q1 is  $T_J = 150^\circ\text{C}$ . Based on the above example calculation, the device temperature will stay below the maximum rating even at this high level of current.

### 10.2.2.2 $R_{ILIM}$ Calculation

In this application, the TPS1HB16-Q1 must allow for the maximum DC current with margin but minimize the energy in the switch during a fault condition by minimizing the current limit. For this application, the best  $I_{LIM}$  set point is approximately 8 A. [公式 7](#) allows you to calculate the  $R_{ILIM}$  value that is placed from the  $I_{LIM}$  pins to  $V_{BB}$ .  $R_{ILIM}$  is calculated in  $k\Omega$ .

$$R_{ILIM} = K_{CL} / I_{CL} \quad (7)$$

Because this device is version A, the  $K_{CL}$  value in the [Specifications](#) section is 110 A  $\times$   $k\Omega$ .

$$R_{ILIM} = 110 \text{ (A} \times \text{k}\Omega) / 8 \text{ A} = 13.75 \text{ k}\Omega \quad (8)$$

For a  $I_{LIM}$  of 8 A, the  $R_{ILIM}$  value should be set at around 13.75  $k\Omega$

### 10.2.2.3 Diagnostics

If the resistive heating load is disconnected (heater malfunction), an alert is desired. Open-load detection can be performed in the switch-enabled state with the current sense feature of the TPS1HB16-Q1 device. Under open load condition, the current in the SNS pin will be the fault current and the can be detected from the sense voltage measurement.

#### 10.2.2.3.1 Selecting the $R_{SNS}$ Value

[表 9](#) shows the requirements for the load current sense in this application. The  $K_{SNS}$  value is specified for the device and can be found in the [Specifications](#) section.

**表 9.  $R_{SNS}$  Calculation Parameters**

PARAMETER	EXAMPLE VALUE
Current Sense Ratio ( $K_{SNS}$ )	3000
Largest diagnosable load current	12 A
Smallest diagnosable load current	60 mA
Full-scale ADC voltage	5 V
ADC resolution	10 bit

The load current measurement requirements of 12 A ensures that even in the event of a overcurrent surpassing the set current limit, the MCU can register and react by shutting down the TPS1HB16-Q1, while the low level of 60 mA allows for accurate measurement of low load currents.

The  $R_{SNS}$  resistor value should be selected such that the largest diagnosable load current puts  $V_{SNS}$  at about 95% of the ADC full-scale. With this design, any ADC value above 95% can be considered a fault. Additionally, the  $R_{SNS}$  resistor value should ensure that the smallest diagnosable load current does not cause  $V_{SNS}$  to fall below 1 LSB of the ADC. With the given example values, a 1.2-k $\Omega$  sense resistor satisfies both requirements shown in [表 10](#).

**表 10.  $V_{SNS}$  Calculation**

LOAD (A)	SENSE RATIO	$I_{SNS}$ (mA)	$R_{SNS}$ ( $\Omega$ )	$V_{SNS}$ (V)	% of 5-V ADC
0.06	3000	0.02	1200	0.024	0.5%
12	3000	4	1200	4.800	96.0%

## 11 Power Supply Recommendations

The TPS1HB16-Q1 device is designed to operate in a 12-V automotive system. The nominal supply voltage range is 6 V to 18 V as measured at the  $V_{BB}$  pin with respect to the GND pin of the device. In this range the device meets full parametric specifications as listed in the [Electrical Characteristics](#) table. The device is also designed to withstand voltage transients beyond this range. When operating outside of the nominal voltage range but within the operating voltage range, the device will exhibit normal functional behavior. However, parametric specifications may not be specified outside the nominal supply voltage range.

**表 11. Operating Voltage Range**

$V_{BB}$ Voltage Range	Note
3 V to 6 V	Transients such as cold crank and start-stop, functional operation are specified but some parametric specifications may not apply. The device is completely short-circuit protected up to 125°C
6 V to 18 V	Nominal supply voltage, all parametric specifications apply. The device is completely short-circuit protected up to 125°C
18 V to 40 V	Transients such as jump-start and load-dump, functional operation specified but some parametric specifications may not apply

## 12 Layout

### 12.1 Layout Guidelines

To achieve optimal thermal performance, connect the exposed pad to a large copper pour. On the top PCB layer, the pour may extend beyond the package dimensions as shown in the example below. In addition to this, it is recommended to also have a  $V_{BB}$  plane either on one of the internal PCB layers or on the bottom layer.

Vias should connect this plane to the top  $V_{BB}$  pour.

Ensure that all external components are placed close to the pins. Device current limiting performance can be harmed if the  $R_{ILIM}$  is far from the pins and extra parasitics are introduced.

### 12.2 Layout Example

The layout example is for device versions A/B.



图 18. 16-PWP Layout Example

## 13 器件和文档支持

### 13.1 文档支持

#### 13.1.1 相关文档

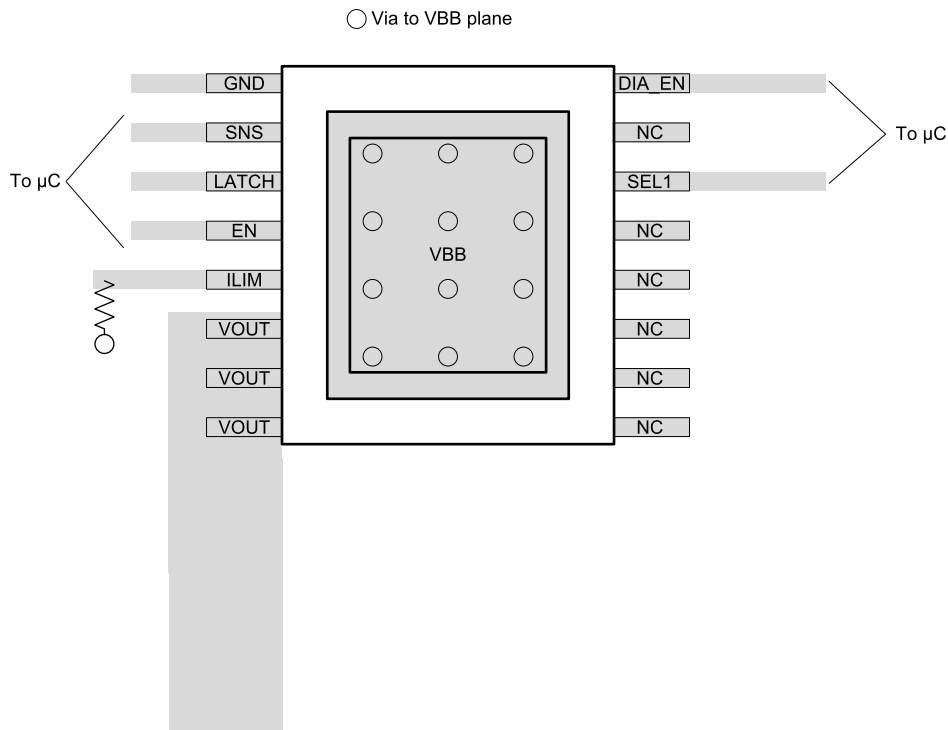
请参阅如下相关文档:

- TI 《如何利用智能高侧开关驱动电感、电容和照明负载》
- TI 《智能电源开关的短路可靠性测试》
- TI 《适用于高侧开关的反向电池保护》
- TI 《智能电源开关的可调电流限制》

### 13.2 接收文档更新通知

要接收文档更新通知, 请导航至 TI.com.cn 上的器件产品文件夹。单击右上角的 [通知我](#) 进行注册, 即可每周接收产品信息更改摘要。有关更改的详细信息, 请查看任何已修订文档中包含的修订历史记录。

### 13.3 社区资源

The following links connect to TI community resources. Linked contents are provided "AS IS" by the respective contributors. They do not constitute TI specifications and do not necessarily reflect TI's views; see TI's [Terms of Use](#).

**TI E2E™ Online Community** *TI's Engineer-to-Engineer (E2E) Community*. Created to foster collaboration among engineers. At e2e.ti.com, you can ask questions, share knowledge, explore ideas and help solve problems with fellow engineers.

**Design Support** *TI's Design Support* Quickly find helpful E2E forums along with design support tools and contact information for technical support.

### 13.4 商标

E2E is a trademark of Texas Instruments.

### 13.5 静电放电警告



ESD 可能会损坏该集成电路。德州仪器 (TI) 建议通过适当的预防措施处理所有集成电路。如果不遵守正确的处理措施和安装程序, 可能会损坏集成电路。

ESD 的损坏小至导致微小的性能降级, 大至整个器件故障。精密的集成电路可能更容易受到损坏, 这是因为非常细微的参数更改都可能会导致器件与其发布的规格不相符。

### 13.6 Glossary

[SLYZ022](#) — *TI Glossary*.

This glossary lists and explains terms, acronyms, and definitions.

## 14 机械、封装和可订购信息

以下页面包含机械、封装和可订购信息。这些信息是指定器件的最新可用数据。数据如有变更, 恕不另行通知, 且不会对此文档进行修订。如需获取此数据表的浏览器版本, 请查阅左侧的导航栏。

## 重要声明和免责声明



TI 均以“原样”提供技术性数据（包括数据表）、设计资源（包括参考设计）、应用或其他设计建议、网络工具、安全信息和其他资源，不保证其中不含任何瑕疵，且不做任何明示或暗示的担保，包括但不限于对适销性、适合某特定用途或不侵犯任何第三方知识产权的暗示担保。

所述资源可供专业开发人员应用TI 产品进行设计使用。您将对以下行为独自承担全部责任：(1) 针对您的应用选择合适的TI 产品；(2) 设计、验证并测试您的应用；(3) 确保您的应用满足相应标准以及任何其他安全、安保或其他要求。所述资源如有变更，恕不另行通知。TI 对您使用所述资源的授权仅限于开发资源所涉及TI 产品的相关应用。除此之外不得复制或展示所述资源，也不提供其它TI 或任何第三方的知识产权授权许可。如因使用所述资源而产生任何索赔、赔偿、成本、损失及债务等，TI 对此概不负责，并且您须赔偿由此对TI 及其代表造成的损害。

TI 所提供产品均受TI 的销售条款 (<http://www.ti.com.cn/zh-cn/legal/termsofsale.html>) 以及ti.com.cn上或随附TI产品提供的其他可适用条款的约束。TI提供所述资源并不扩展或以其他方式更改TI 针对TI 产品所发布的可适用的担保范围或担保免责声明。

邮寄地址：上海市浦东新区世纪大道 1568 号中建大厦 32 楼，邮政编码：200122  
Copyright © 2019 德州仪器半导体技术（上海）有限公司

**PACKAGING INFORMATION**

Orderable Device	Status (1)	Package Type	Package Drawing	Pins	Package Qty	Eco Plan (2)	Lead finish/ Ball material (6)	MSL Peak Temp (3)	Op Temp (°C)	Device Marking (4/5)	Samples
TPS1HB16AQPWPRQ1	ACTIVE	HTSSOP	PWP	16	3000	RoHS-Exempt & Green	NIPDAU	Level-3-260C-168HRS	-40 to 125	1HB16AQ	
TPS1HB16BQPWPRQ1	ACTIVE	HTSSOP	PWP	16	3000	RoHS-Exempt & Green	NIPDAU	Level-3-260C-168HRS	-40 to 125	1HB16BQ	
TPS1HB16FQPWPRQ1	ACTIVE	HTSSOP	PWP	16	3000	RoHS-Exempt & Green	NIPDAU	Level-3-260C-168HRS	-40 to 125	1HB16FQ	

(1) The marketing status values are defined as follows:

**ACTIVE:** Product device recommended for new designs.

**LIFEBUY:** TI has announced that the device will be discontinued, and a lifetime-buy period is in effect.

**NRND:** Not recommended for new designs. Device is in production to support existing customers, but TI does not recommend using this part in a new design.

**PREVIEW:** Device has been announced but is not in production. Samples may or may not be available.

**OBSOLETE:** TI has discontinued the production of the device.

(2) **RoHS:** TI defines "RoHS" to mean semiconductor products that are compliant with the current EU RoHS requirements for all 10 RoHS substances, including the requirement that RoHS substance do not exceed 0.1% by weight in homogeneous materials. Where designed to be soldered at high temperatures, "RoHS" products are suitable for use in specified lead-free processes. TI may reference these types of products as "Pb-Free".

**RoHS Exempt:** TI defines "RoHS Exempt" to mean products that contain lead but are compliant with EU RoHS pursuant to a specific EU RoHS exemption.

**Green:** TI defines "Green" to mean the content of Chlorine (Cl) and Bromine (Br) based flame retardants meet JS709B low halogen requirements of <=1000ppm threshold. Antimony trioxide based flame retardants must also meet the <=1000ppm threshold requirement.

(3) MSL, Peak Temp. - The Moisture Sensitivity Level rating according to the JEDEC industry standard classifications, and peak solder temperature.

(4) There may be additional marking, which relates to the logo, the lot trace code information, or the environmental category on the device.

(5) Multiple Device Markings will be inside parentheses. Only one Device Marking contained in parentheses and separated by a "~" will appear on a device. If a line is indented then it is a continuation of the previous line and the two combined represent the entire Device Marking for that device.

(6) Lead finish/Ball material - Orderable Devices may have multiple material finish options. Finish options are separated by a vertical ruled line. Lead finish/Ball material values may wrap to two lines if the finish value exceeds the maximum column width.

**Important Information and Disclaimer:**The information provided on this page represents TI's knowledge and belief as of the date that it is provided. TI bases its knowledge and belief on information provided by third parties, and makes no representation or warranty as to the accuracy of such information. Efforts are underway to better integrate information from third parties. TI has taken and continues to take reasonable steps to provide representative and accurate information but may not have conducted destructive testing or chemical analysis on incoming materials and chemicals. TI and TI suppliers consider certain information to be proprietary, and thus CAS numbers and other limited information may not be available for release.

In no event shall TI's liability arising out of such information exceed the total purchase price of the TI part(s) at issue in this document sold by TI to Customer on an annual basis.

**TAPE AND REEL INFORMATION**

**QUADRANT ASSIGNMENTS FOR PIN 1 ORIENTATION IN TAPE**

\*All dimensions are nominal

Device	Package Type	Package Drawing	Pins	SPQ	Reel Diameter (mm)	Reel Width W1 (mm)	A0 (mm)	B0 (mm)	K0 (mm)	P1 (mm)	W (mm)	Pin1 Quadrant
TPS1HB16AQPWRQ1	HTSSOP	PWP	16	3000	330.0	12.4	6.9	5.6	1.6	8.0	12.0	Q1
TPS1HB16BQPWRQ1	HTSSOP	PWP	16	3000	330.0	12.4	6.9	5.6	1.6	8.0	12.0	Q1
TPS1HB16FQPWRQ1	HTSSOP	PWP	16	3000	330.0	12.4	6.9	5.6	1.6	8.0	12.0	Q1

## TAPE AND REEL BOX DIMENSIONS



\*All dimensions are nominal

Device	Package Type	Package Drawing	Pins	SPQ	Length (mm)	Width (mm)	Height (mm)
TPS1HB16AQPWRQ1	HTSSOP	PWP	16	3000	350.0	350.0	43.0
TPS1HB16BQPWRQ1	HTSSOP	PWP	16	3000	350.0	350.0	43.0
TPS1HB16FQPWRQ1	HTSSOP	PWP	16	3000	350.0	350.0	43.0

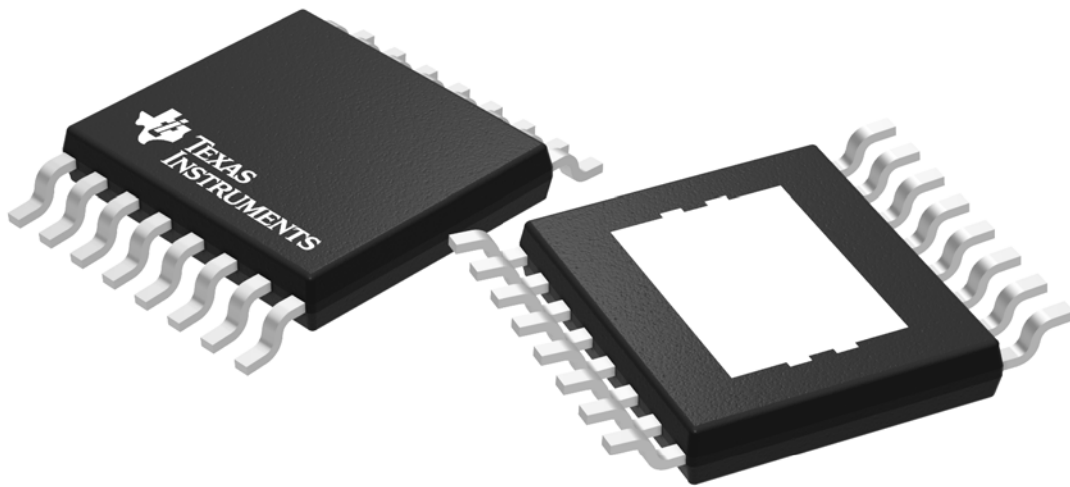

Images above are just a representation of the package family, actual package may vary.  
Refer to the product data sheet for package details.

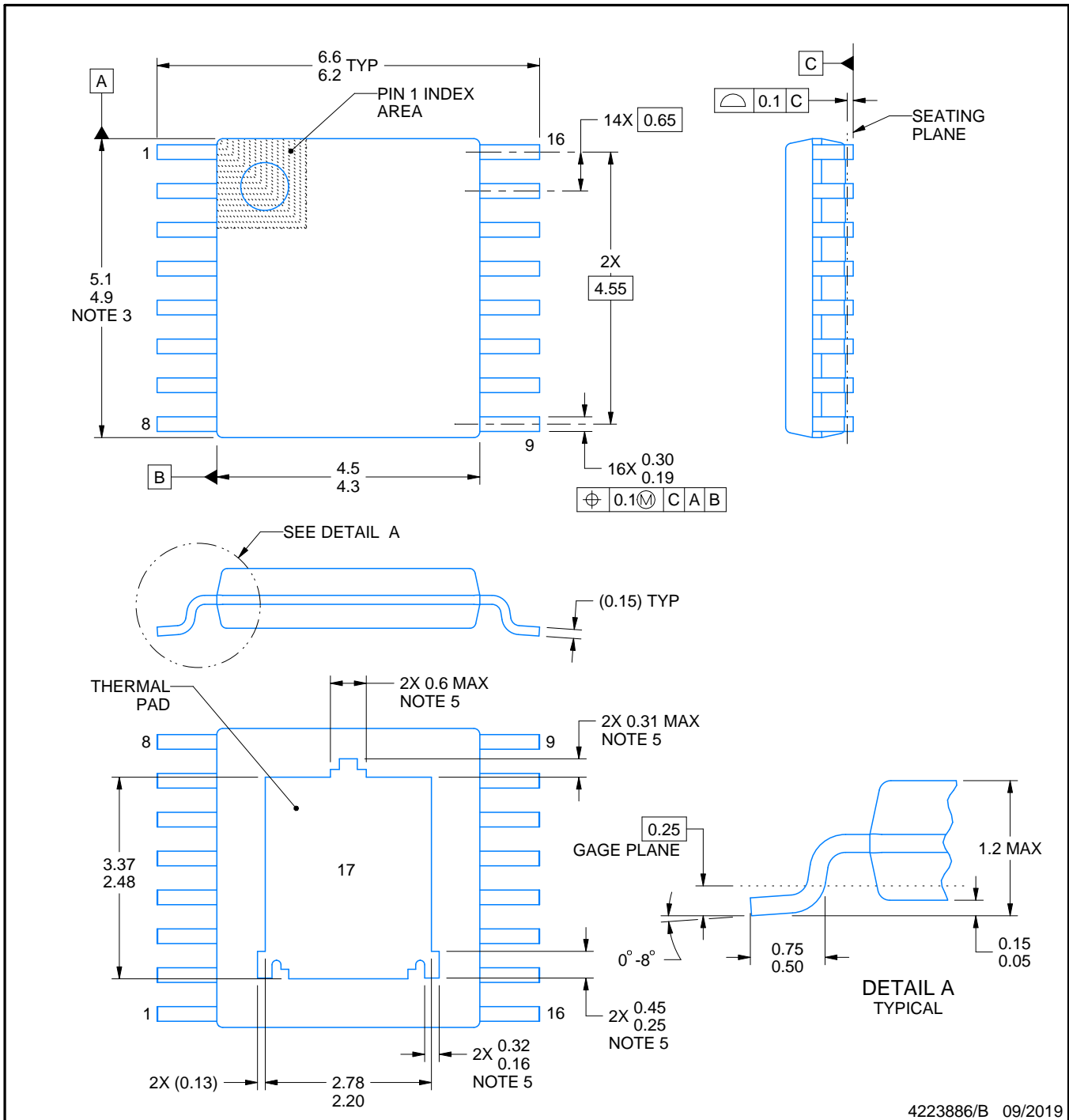
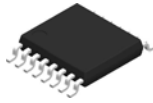

4223886/B 09/2019

NOTES:

PowerPAD is a trademark of Texas Instruments.

1. All linear dimensions are in millimeters. Any dimensions in parenthesis are for reference only. Dimensioning and tolerancing per ASME Y14.5M.
2. This drawing is subject to change without notice.
3. This dimension does not include mold flash, protrusions, or gate burrs. Mold flash, protrusions, or gate burrs shall not exceed 0.15 mm per side.
4. Reference JEDEC registration MO-153.
5. Features may differ or may not be present.



# EXAMPLE STENCIL DESIGN

PWP0016M

PowerPAD™ TSSOP - 1.2 mm max height

SMALL OUTLINE PACKAGE

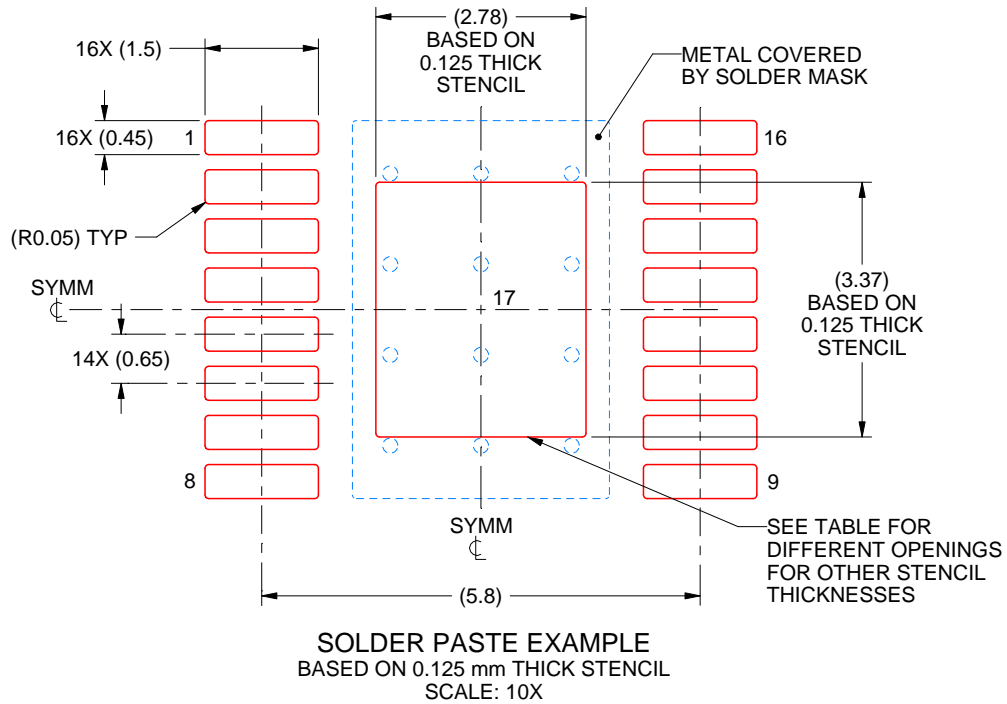

STENCIL THICKNESS	SOLDER STENCIL OPENING
0.1	3.11 X 3.77
0.125	2.78 X 3.37 (SHOWN)
0.15	2.54 X 3.08
0.175	2.35 X 2.85

4223886/B 09/2019

NOTES: (continued)

11. Laser cutting apertures with trapezoidal walls and rounded corners may offer better paste release. IPC-7525 may have alternate design recommendations.
12. Board assembly site may have different recommendations for stencil design.

## 重要声明和免责声明

TI 均以“原样”提供技术性及其可靠性数据（包括数据表）、设计资源（包括参考设计）、应用或其他设计建议、网络工具、安全信息和其他资源，不保证其中不含任何瑕疵，且不做任何明示或暗示的担保，包括但不限于对适销性、适合某特定用途或不侵犯任何第三方知识产权的暗示担保。

所述资源可供专业开发人员应用TI 产品进行设计使用。您将对以下行为独自承担全部责任：(1) 针对您的应用选择合适的TI 产品；(2) 设计、验证并测试您的应用；(3) 确保您的应用满足相应标准以及任何其他安全、安保或其他要求。所述资源如有变更，恕不另行通知。TI 对您使用所述资源的授权仅限于开发资源所涉及TI 产品的相关应用。除此之外不得复制或展示所述资源，也不提供其它TI 或任何第三方的知识产权授权许可。如因使用所述资源而产生任何索赔、赔偿、成本、损失及债务等，TI 对此概不负责，并且您须赔偿由此对TI 及其代表造成的损害。

TI 所提供产品均受TI 的销售条款 (<http://www.ti.com.cn/zh-cn/legal/termsofsale.html>) 以及 [ti.com.cn](http://www.ti.com.cn) 上或随附TI 产品提供的其他可适用条款的约束。TI 提供所述资源并不扩展或以其他方式更改TI 针对TI 产品所发布的可适用的担保范围或担保免责声明。

邮寄地址：上海市浦东新区世纪大道 1568 号中建大厦 32 楼，邮政编码：200122  
Copyright © 2020 德州仪器半导体技术（上海）有限公司