

CDCVF2505 3.3-V Clock Phase-Lock Loop Clock Driver

1 Features

- Phase-Lock Loop Clock Driver for Synchronous DRAM and General-Purpose Applications
- Spread Spectrum Clock Compatible
- Operating Frequency: 24 MHz to 200 MHz
- Low Jitter (Cycle-to-Cycle): < |150 ps| (Over 66 MHz to 200 MHz Range)
- Distributes One Clock Input to One Bank of Five Outputs (CLKOUT Used to Tune the Input-Output Delay)
- Three-States Outputs When There Is No Input Clock
- Operates From Single 3.3-V Supply
- Available in 8-Pin TSSOP and 8-Pin SOIC Packages
- Consumes Less Than 100 mA (Typical) in Power-Down Mode
- Internal Feedback Loop Is Used to Synchronize the Outputs to the Input Clock
- 25-Ω On-Chip Series Damping Resistors
- Integrated RC PLL Loop Filter Eliminates the Need for External Components

2 Applications

- Synchronous DRAMs
- Industrial Applications
- General-Purpose Zero-Delay Clock Buffers

3 Description

The CDCVF2505 is a high-performance, low-skew, low-jitter, phase-lock loop (PLL) clock driver. This device uses a PLL to precisely align the output clocks (1Y[0-3] and CLKOUT) to the input clock signal (CLKIN) in both frequency and phase. The CDCVF2505 operates at 3.3 V and also provides integrated series-damping resistors that make it ideal for driving point-to-point loads.

One bank of five outputs provides low-skew, low-jitter copies of CLKIN. Output duty cycles are adjusted to 50 percent, independent of duty cycle at CLKIN. The device automatically goes into power-down mode when no input signal is applied to CLKIN.

The loop filter for the PLLs is included on-chip. This minimizes the component count, space, and cost.

The CDCVF2505 is characterized for operation from –40°C to 85°C.

Device Information⁽¹⁾

PART NUMBER	PACKAGE	BODY SIZE (NOM)
CDCVF2505	SOIC (8)	4.90 mm × 3.90 mm
	TSSOP (8)	4.40 mm × 3.00 mm

(1) For all available packages, see the orderable addendum at the end of the data sheet.

Functional Block Diagram

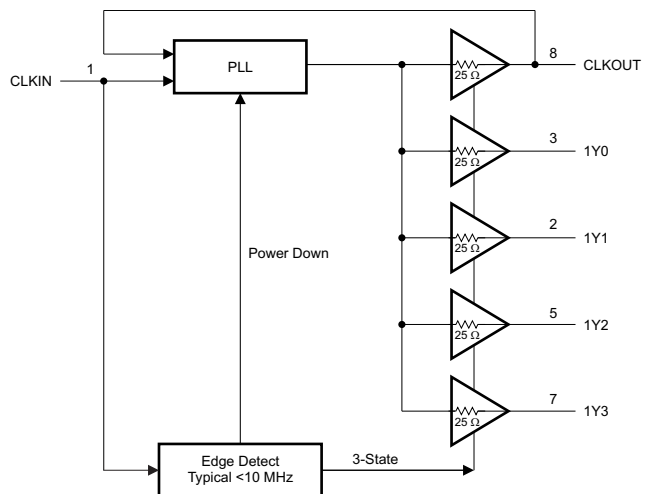

B0248-01

Copyright © 2016, Texas Instruments Incorporated



Table of Contents

1 Features	1	9.2 Functional Block Diagram	8
2 Applications	1	9.3 Feature Description	8
3 Description	1	9.4 Device Functional Modes	9
4 Revision History	2	10 Application and Implementation	10
5 Description (continued)	3	10.1 Application Information	10
6 Pin Configuration and Functions	3	10.2 Typical Application	10
7 Specifications	4	11 Power Supply Recommendations	12
7.1 Absolute Maximum Ratings	4	12 Layout	12
7.2 ESD Ratings	4	12.1 Layout Guidelines	12
7.3 Recommended Operating Conditions	4	12.2 Layout Example	12
7.4 Thermal Information	4	13 Device and Documentation Support	13
7.5 Electrical Characteristics	5	13.1 Documentation Support	13
7.6 Timing Requirements	5	13.2 Receiving Notification of Documentation Updates	13
7.7 Switching Characteristics	6	13.3 Community Resources	13
7.8 Typical Characteristics	6	13.4 Trademarks	13
8 Parameter Measurement Information	7	13.5 Electrostatic Discharge Caution	13
9 Detailed Description	8	13.6 Glossary	13
9.1 Overview	8	14 Mechanical, Packaging, and Orderable Information	13

4 Revision History

NOTE: Page numbers for previous revisions may differ from page numbers in the current version.

Changes from Revision F (February 2012) to Revision G

Page

• Added <i>ESD Ratings</i> table, <i>Feature Description</i> section, <i>Device Functional Modes</i> , <i>Application and Implementation</i> section, <i>Power Supply Recommendations</i> section, <i>Layout</i> section, <i>Device and Documentation Support</i> section, and <i>Mechanical, Packaging, and Orderable Information</i> section	1
• Changed $R_{\theta JA}$ value for D package from 165.5 : to 112.3°C/W	4
• Changed $R_{\theta JA}$ value for PW package from 230.5112.3°C/W : to 175.8°C/W	4
• Updated values in the <i>Thermal Information</i> table to align with JEDEC standards.	4

5 Description (continued)

Because it is based on the PLL circuitry, the CDCVF2505 requires a stabilization time to achieve phase lock of the feedback signal to the reference signal. This stabilization is required following power up and application of a fixed-frequency, fixed-phase signal at CLKIN, and following any changes to the PLL reference.

6 Pin Configuration and Functions

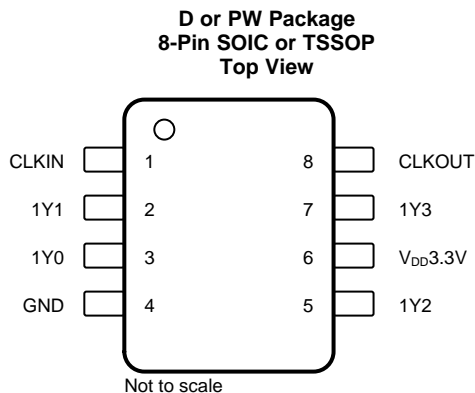

Pin Functions

PIN		TYPE ⁽¹⁾	DESCRIPTION
NAME	NO.		
1Y[0–3]	2, 3, 5, 7	O	Clock outputs. These outputs are low-skew copies of CLKIN. Each output has an integrated 25-Ω series damping resistor.
CLKIN	1	I	Clock input. CLKIN provides the clock signal to be distributed by the CDCVF2505 clock driver. CLKIN is used to provide the reference signal to the integrated PLL that generates the clock output signals. CLKIN must have a fixed frequency and fixed phase for the PLL to obtain phase lock. Once the circuit is powered up and a valid signal is applied, a stabilization time (100 μs) is required for the PLL to phase lock the feedback signal to CLKIN.
CLKOUT	8	O	Feedback output. CLKOUT completes the internal feedback loop of the PLL. This connection is made inside the chip and an external feedback loop should NOT be connected. CLKOUT can be loaded with a capacitor to achieve zero delay between CLKIN and the Y outputs.
GND	4	P	Ground
V _{DD} 3.3V	6	P	3.3-V supply

(1) I = Input, O = Output, and P = Power

7 Specifications

7.1 Absolute Maximum Ratings

 over operating free-air temperature range (unless otherwise noted)⁽¹⁾

		MIN	MAX	UNIT
V_{DD}	Supply voltage	-0.5	4.3	V
V_I	Input voltage ⁽²⁾⁽³⁾	-0.5	$V_{DD} + 0.5$	V
V_O	Output voltage ⁽²⁾⁽³⁾	-0.5	$V_{DD} + 0.5$	V
I_{IK}	Input clamp current ($V_I < 0$ or $V_I > V_{DD}$)		±50	mA
I_{OK}	Output clamp current ($V_O < 0$ or $V_O > V_{DD}$)		±50	mA
I_O	Continuous total output current ($V_O = 0$ to V_{DD})		±50	mA
T_{stg}	Storage temperature	-65	150	°C

- (1) Stresses beyond those listed under *Absolute Maximum Ratings* may cause permanent damage to the device. These are stress ratings only, and functional operation of the device at these or any other conditions beyond those indicated under *Recommended Operating Conditions* is not implied. Exposure to absolute-maximum-rated conditions for extended periods may affect device reliability.
- (2) The input and output negative-voltage ratings may be exceeded if the input and output clamp-current ratings are observed.
- (3) This value is limited to 4.3 V maximum.

7.2 ESD Ratings

		VALUE	UNIT
$V_{(ESD)}$	Electrostatic discharge	Human-body model (HBM), per ANSI/ESDA/JEDEC JS-001 ⁽¹⁾	±2000
		Charged-device model (CDM), per JEDEC specification JESD22-C101 ⁽²⁾	±1000
		Machine model (MM)	±300

- (1) JEDEC document JEP155 states that 500-V HBM allows safe manufacturing with a standard ESD control process.
- (2) JEDEC document JEP157 states that 250-V CDM allows safe manufacturing with a standard ESD control process.

7.3 Recommended Operating Conditions

over operating free-air temperature range (unless otherwise noted)

		MIN	NOM	MAX	UNIT
V_{DD}	Supply voltage	3	3.3	3.6	V
V_{IH}	High-level input voltage	0.7 V_{DD}			V
V_{IL}	Low-level input voltage	0.3 V_{DD}			V
V_I	Input voltage	0		V_{DD}	V
I_{OH}	High-level output current			-12	mA
I_{OL}	Low-level output current			12	mA
T_A	Operating free-air temperature	-40		85	°C

7.4 Thermal Information

THERMAL METRIC ⁽¹⁾	CDCVF2505		UNIT	
	D (SOIC)	PW (TSSOP)		
	8 PINS	8 PINS		
$R_{\theta JA}$	Junction-to-ambient thermal resistance ⁽²⁾	112.3	175.8	°C/W
$R_{\theta JC(top)}$	Junction-to-case (top) thermal resistance	55.8	61.8	°C/W
$R_{\theta JB}$	Junction-to-board thermal resistance	53.1	104.3	°C/W
ψ_{JT}	Junction-to-top characterization parameter	12.8	7.7	°C/W
ψ_{JB}	Junction-to-board characterization parameter	52.5	102.6	°C/W
$R_{\theta JC(bot)}$	Junction-to-case (bottom) thermal resistance	—	—	°C/W

- (1) For more information about traditional and new thermal metrics, see the [Semiconductor and IC Package Thermal Metrics](#) application report.
- (2) The package thermal impedance is calculated in accordance with JESD 51.

7.5 Electrical Characteristics

over recommended operating free-air temperature range (unless otherwise noted)

PARAMETER		TEST CONDITIONS	MIN	TYP ⁽¹⁾	MAX	UNIT	
V _{IK}	Input voltage	I _I = -18 mA, V _{DD} = 3 V			-1.2	V	
V _{OH}	High-level output voltage	I _{OH} = -100 μA, V _{DD} = MIN to MAX	V _{DD} - 0.2			V	
		I _{OH} = -12 mA, V _{DD} = 3 V	2.1				
		I _{OH} = -6 mA, V _{DD} = 3 V	2.4				
V _{OL}	Low-level output voltage	I _{OH} = 100 μA, V _{DD} = MIN to MAX			0.2	V	
		I _{OH} = 12 mA, V _{DD} = 3 V			0.8		
		I _{OH} = 6 mA, V _{DD} = 3 V			0.55		
I _{OH}	High-level output current	V _O = 1 V, V _{DD} = 3 V	-27			mA	
		V _O = 1.65 V, V _{DD} = 3.3 V			-36		
I _{OL}	Low-level output current	V _O = 2 V, V _{DD} = 3 V	27			mA	
		V _O = 1.65 V, V _{DD} = 3.3 V			40		
I _I	Input current	V _I = 0 V or V _{DD}			±5	μA	
C _I	Input capacitance	V _I = 0 V or V _{DD} , V _{DD} = 3.3 V			4.2	pF	
C _O	Output capacitance	V _I = 0 V or V _{DD} , V _{DD} = 3.3 V	Y _n			2.8	pF
			CLKOUT			5.2	

(1) All typical values are at respective nominal V_{DD} and 25°C

7.6 Timing Requirements

over recommended operating free-air temperature range (unless otherwise noted)

		MIN	TYP	MAX	UNIT
SUPPLY VOLTAGE, V_{DD} = 3.3 V ±0.3 V					
f _{clk}	Clock frequency	24		200	MHz
	Input clock duty cycle	24 MHz to 85 MHz ⁽¹⁾		30%	85%
		86 MHz to 200 MHz		40%	50% 60%
	Stabilization time ⁽²⁾			100	μs
SUPPLY VOLTAGE, V_{DD} = 2.7 V					
f _{clk}	Clock frequency	42		166	MHz
	Input clock duty cycle	42 MHz to 85 MHz ⁽¹⁾		30%	70%
		86 MHz to 166 MHz		40%	50% 60%
	Stabilization time ⁽²⁾			100	μs

(1) Assured by design but not 100% production tested

(2) Time required for the integrated PLL circuit to obtain phase lock of its feedback signal to its reference signal. For phase lock to be obtained, a fixed-frequency, fixed-phase reference signal must be present at CLKIN. Until phase lock is obtained, the specifications for propagation delay, skew, and jitter parameters given in the switching characteristics table are not applicable. This parameter does not apply for input modulation under SSC application.

7.7 Switching Characteristics

over recommended ranges of supply voltage and operating free-air temperature, $C_L = 25 \text{ pF}$, $V_{DD} = 3.3 \text{ V} \pm 0.3 \text{ V}^{(1)}$

PARAMETER	TEST CONDITIONS	MIN	TYP ⁽²⁾	MAX	UNIT	
t_{pd}	Propagation delay, normalized (see Figure 2)	CLKIN to Y_n , $f = 66 \text{ MHz to } 200 \text{ MHz}$		-150	150	ps
$t_{sk(o)}$	Output skew ⁽³⁾	Y_n to Y_n			150	ps
$t_{c(jit_cc)}$	Jitter (cycle-to-cycle) (see Figure 4)	$f = 66 \text{ MHz to } 200 \text{ MHz}$			70	ps
		$f = 24 \text{ MHz to } 50 \text{ MHz}$			200	
odc	Output duty cycle (see Figure 3)	$f = 24 \text{ MHz to } 200 \text{ MHz}$ at 50% V_{DD}		45%	55%	
t_r	Rise time	$V_O = 0.4 \text{ V to } 2 \text{ V}$		0.5	2	ns
t_f	Fall time	$V_O = 2 \text{ V to } 0.4 \text{ V}$		0.5	2	ns

- (1) Time required for the integrated PLL circuit to obtain phase lock of its feedback signal to its reference signal. For phase lock to be obtained, a fixed-frequency, fixed-phase reference signal must be present at CLKIN. Until phase lock is obtained, the specifications for propagation delay, skew, and jitter parameters given in the switching characteristics table are not applicable. This parameter does not apply for input modulation under SSC application.
- (2) All typical values are at respective nominal V_{DD} and 25°C
- (3) The $t_{sk(o)}$ specification is only valid for equal loading of all outputs.

7.8 Typical Characteristics

at 3.3 V, 25°C (unless otherwise noted)

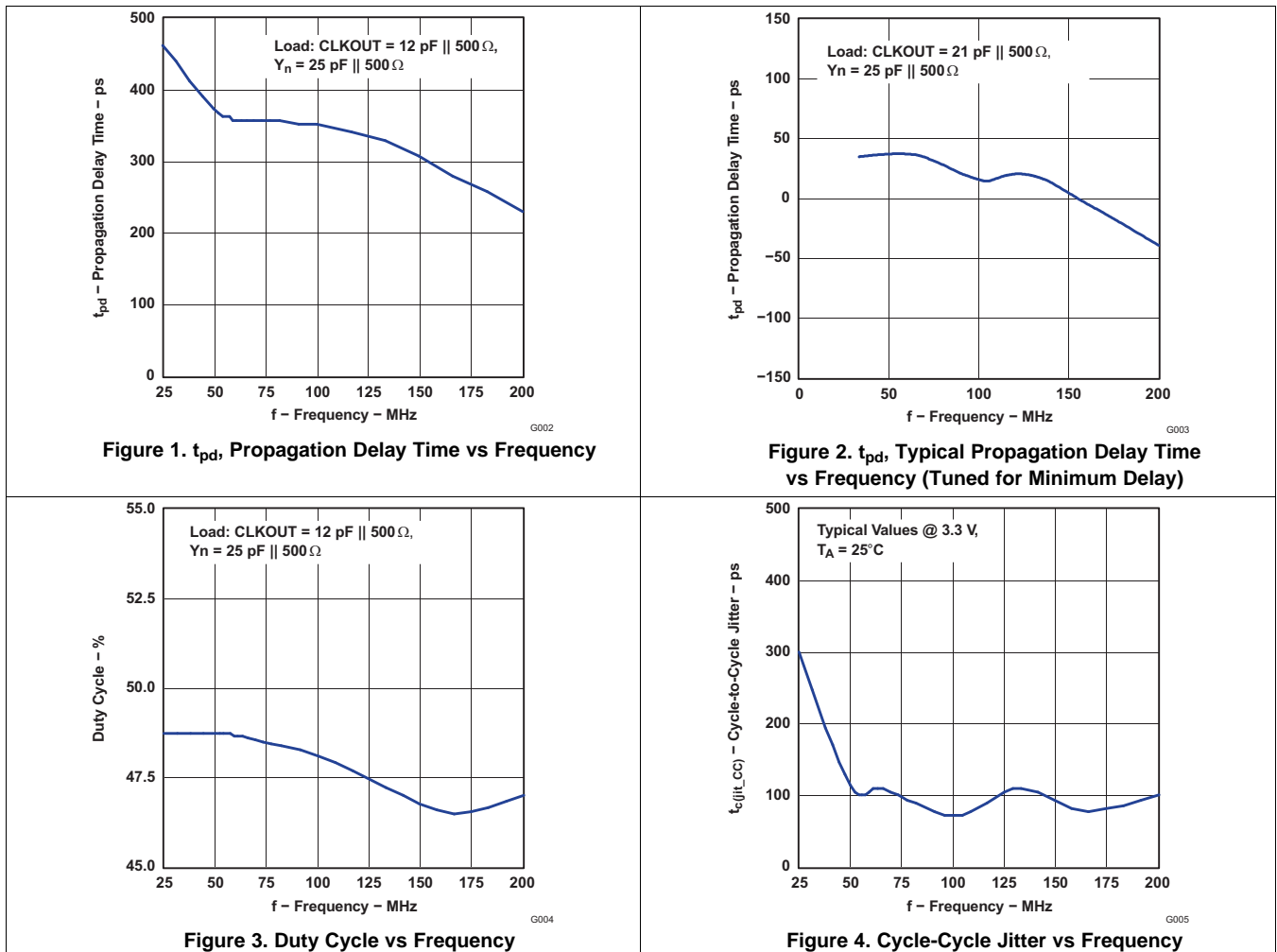

8 Parameter Measurement Information

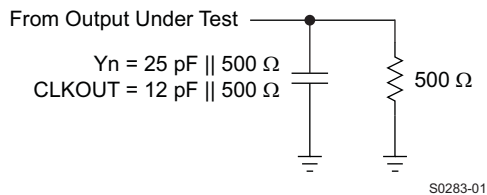

Figure 5. Test Load Circuit

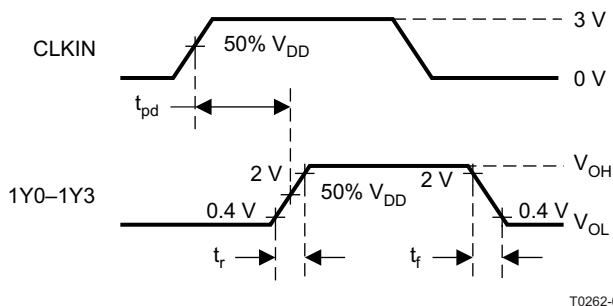

Figure 6. Voltage Threshold for Measurements, Propagation Delay (T_{pd})

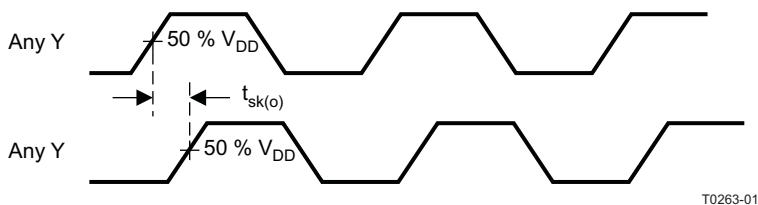

Figure 7. Output Skew

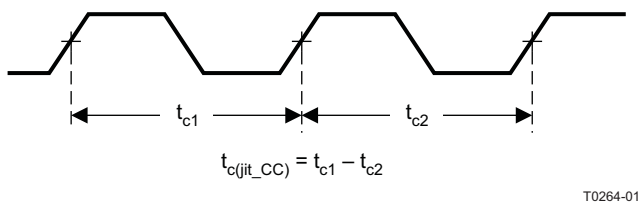

Figure 8. Cycle-to-Cycle Jitter

9 Detailed Description

9.1 Overview

The CDCVF2505 is designed for synchronous DRAM in server systems. This makes the device ideal for applications which require the lowest possible skew between a provided reference clock and the clock copies generated from the internal oscillator. At the same time, the phase-locked-loop has a high enough bandwidth to track a spread-spectrum reference clock.

9.2 Functional Block Diagram

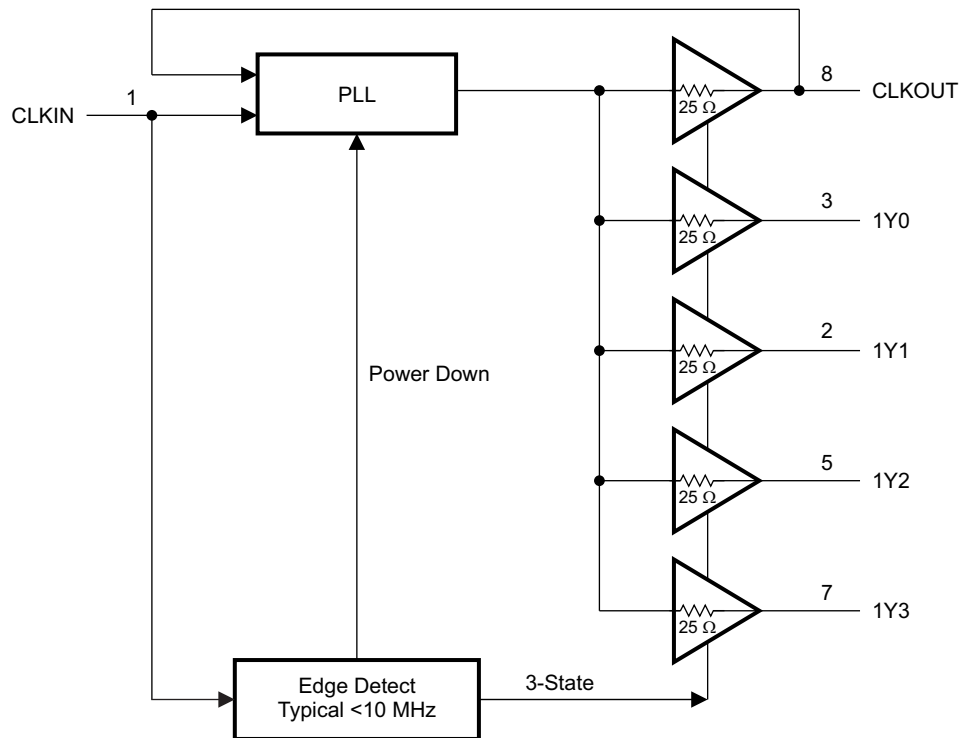

B0246-01

Copyright © 2016, Texas Instruments Incorporated

9.3 Feature Description

The CDCVF2505 provides a single high-impedance reference input to a phase-locked-loop circuit (PLL). The reference is directly fed to a phase comparator. The control circuit loop filter is integrated into the device. The oscillator output is fed to a clock tree with five output buffers. One of them is used as feedback to close the loop of the PLL circuit. ⁽⁴⁾ The feedback path is designed for lowest phase difference or skew seen between reference input and outputs. With respect to the supported reference frequency range the seen phase difference is negligible to the clock period. Thus the CDCVF2505 is categorized as a *Zero Delay PLL*.

The CDCVF2505 contains an reference clock detector. This edge detector connected to CLKIN pin automatically powers down the PLL and tri-states the output buffers to save power, as soon as the input reference frequency goes below the minimum operating frequency range.

(4) The CLKOUT pin shall not be used to drive a trace, but only for delay tuning.

9.4 Device Functional Modes

The device has two functional modes: active and power down.

The CDCVF2505 automatically switches from active to power down, and vice versa, when the detected CLKIN reference frequency is low. The PLL automatically switches on and tries to lock to the reference clock as soon as the input frequency exceeds 20 MHz (typical). The PLL switches off and tri-states the output buffers when the input frequency goes below 12 MHz (typical).

Table 1. Function Table

INPUT	OUTPUTS	
CLKIN	1Y (0:3)	CLKOUT
L	L	L
H	H	H
≤ 1 MHz ⁽¹⁾	Z	Z

- (1) Full device functionality is specified for frequencies equal to or higher than 24 MHz. Below 1 MHz, the device goes in power-down mode in which the PLL is turned off and the outputs enter into Hi-Z mode.

10 Application and Implementation

NOTE

Information in the following applications sections is not part of the TI component specification, and TI does not warrant its accuracy or completeness. TI's customers are responsible for determining suitability of components for their purposes. Customers should validate and test their design implementation to confirm system functionality.

10.1 Application Information

The CDCVF2505 is designed for ease of use. The internal PLL operates without additional configuration required by the user.

10.2 Typical Application

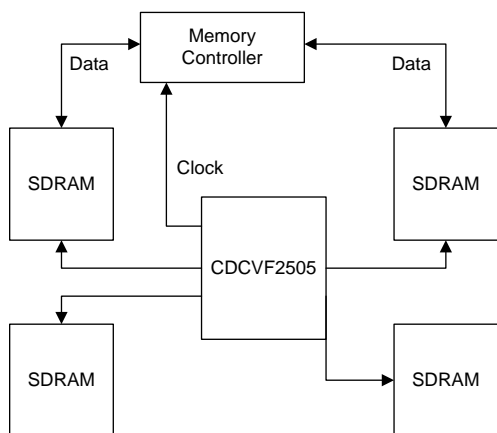

Copyright © 2016, Texas Instruments Incorporated

Figure 9. Typical SDRAM Application

10.2.1 Design Requirements

The CLKOUT pin can be used to optimize the feedback delay using discrete capacitors placed at the pin to introduce additional delay on the feedback signal.

10.2.2 Detailed Design Procedure

The following steps describe how to optimize the propagation delay of the PLL:

- Determine the average output load seen by all clock outputs Y[3:0].
- Decide how the phase relationship between the CLKIN reference and the clock outputs shall be:
 - zero delay
 - leading CLKIN phase with respect to Y[3:0].
 - lagging CLKIN phase with respect to Y[3:0].
- Look up an initial typical value for the *delta load* using [Figure 10](#):
 - for zero delay: match the loading
 - for leading CLKIN phase: load CLKOUT less than Y[3:0]
 - for lagging CLKIN phase: load CLKOUT more than Y[3:0]

Typical Application (continued)

10.2.3 Application Curves

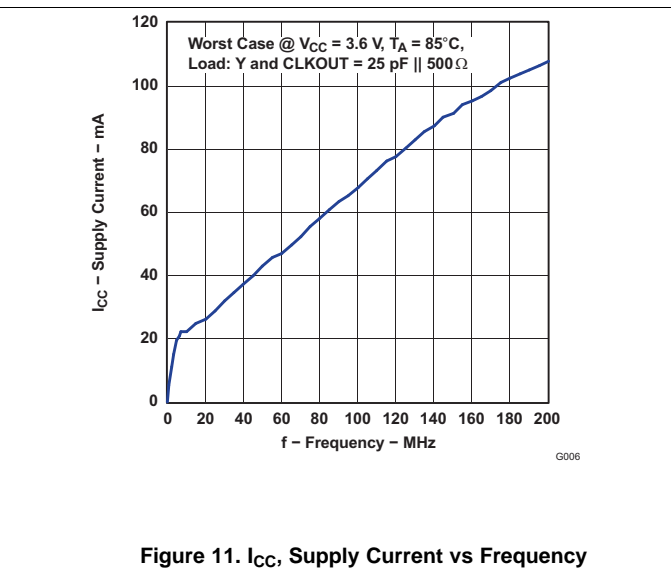
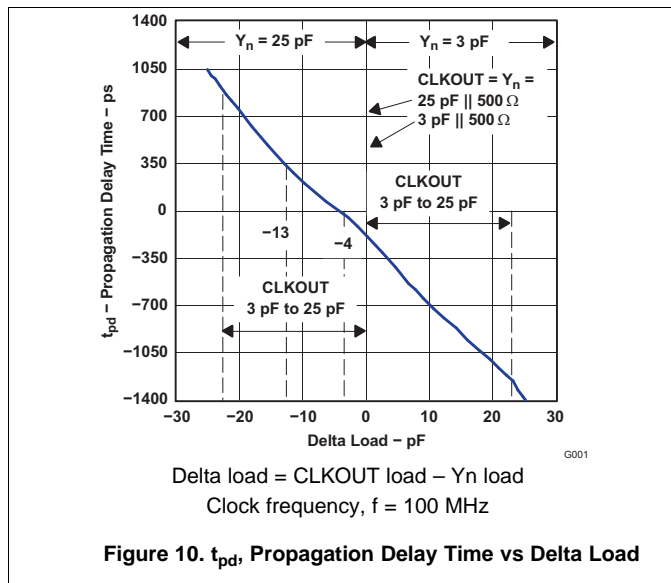

11 Power Supply Recommendations

The power supply decoupling can be optimized to the power plane capacitance and resonance, which is determined by the circuit board size and dielectric material for the buffered frequency of interest. Details can be found in [Design and Layout Guidelines for the CDCVF2505 Clock Driver](#) (SCAA045). For basic functionality, the device shall receive at least 100 nF as local decoupling capacitor.

12 Layout

12.1 Layout Guidelines

TI recommends the following layout guidelines for designing in the CDCVF2505 on a printed-circuit board:

- Provide a full ground or reference plane for the clock traces and the decoupling section.
- Ground floods including stitching using VIAs help prevent the clock injecting spectral lines to surrounding components.
- The decoupling must be placed very close to the device package. The decoupling capacitors can also be placed on the bottom layer of the board. See [Design and Layout Guidelines for the CDCVF2505 Clock Driver](#) (SCAA045) for detailed recommendations.
- The CLKOUT pin can have a very short connection to tuning capacitors for the internal feedback.

12.2 Layout Example

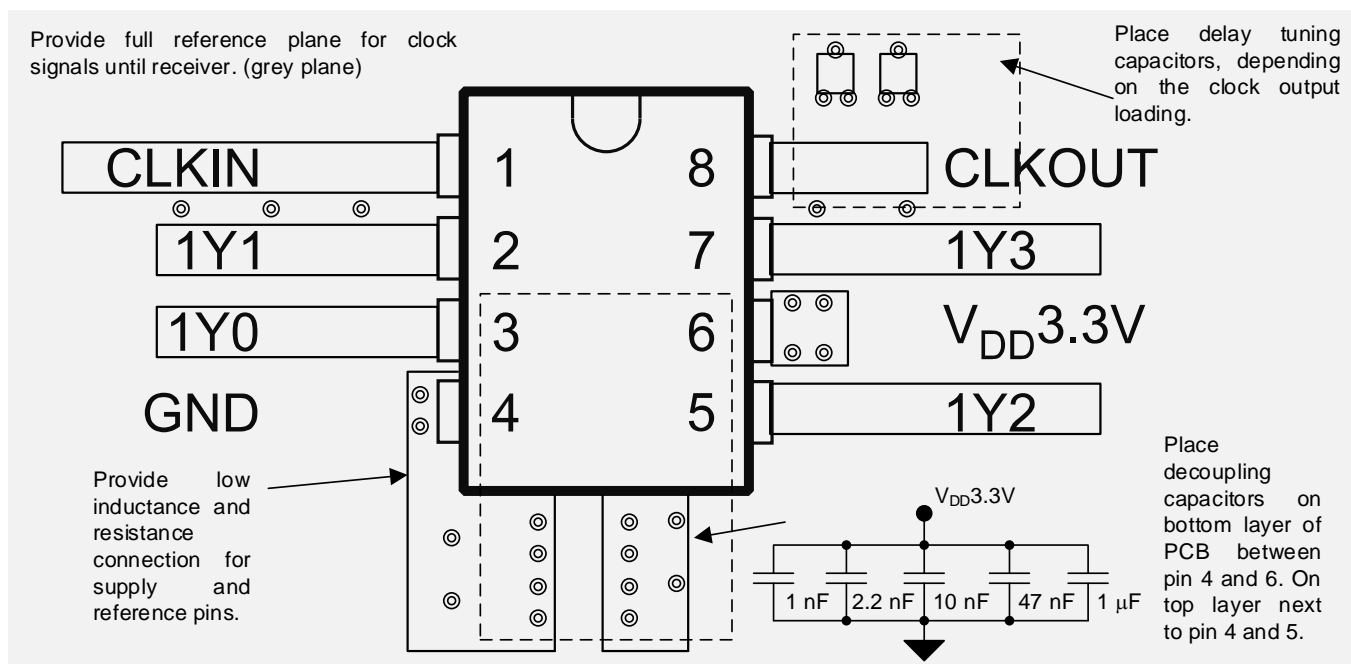

Figure 12. Layout Illustration

13 Device and Documentation Support

13.1 Documentation Support

13.1.1 Related Documentation

For related documentation see the following:

[Design and Layout Guidelines for the CDCVF2505 Clock Driver](#) (SCAA045)

13.2 Receiving Notification of Documentation Updates

To receive notification of documentation updates, navigate to the device product folder on ti.com. In the upper right corner, click on *Alert me* to register and receive a weekly digest of any product information that has changed. For change details, review the revision history included in any revised document.

13.3 Community Resources

The following links connect to TI community resources. Linked contents are provided "AS IS" by the respective contributors. They do not constitute TI specifications and do not necessarily reflect TI's views; see TI's [Terms of Use](#).

TI E2E™ Online Community *TI's Engineer-to-Engineer (E2E) Community*. Created to foster collaboration among engineers. At e2e.ti.com, you can ask questions, share knowledge, explore ideas and help solve problems with fellow engineers.

Design Support *TI's Design Support* Quickly find helpful E2E forums along with design support tools and contact information for technical support.

13.4 Trademarks

E2E is a trademark of Texas Instruments.
All other trademarks are the property of their respective owners.

13.5 Electrostatic Discharge Caution



These devices have limited built-in ESD protection. The leads should be shorted together or the device placed in conductive foam during storage or handling to prevent electrostatic damage to the MOS gates.

13.6 Glossary

[SLYZ022](#) — *TI Glossary*.

This glossary lists and explains terms, acronyms, and definitions.

14 Mechanical, Packaging, and Orderable Information

The following pages include mechanical, packaging, and orderable information. This information is the most current data available for the designated devices. This data is subject to change without notice and revision of this document. For browser-based versions of this data sheet, refer to the left-hand navigation.

PACKAGING INFORMATION

Orderable Device	Status (1)	Package Type	Package Drawing	Pins	Package Qty	Eco Plan (2)	Lead finish/ Ball material (6)	MSL Peak Temp (3)	Op Temp (°C)	Device Marking (4/5)	Samples
CDCVF2505D	ACTIVE	SOIC	D	8	75	RoHS & Green	NIPDAU	Level-1-260C-UNLIM	-40 to 85	CKV05	Samples
CDCVF2505DG4	ACTIVE	SOIC	D	8	75	RoHS & Green	NIPDAU	Level-1-260C-UNLIM	-40 to 85	CKV05	Samples
CDCVF2505DR	ACTIVE	SOIC	D	8	2500	RoHS & Green	NIPDAU	Level-1-260C-UNLIM	-40 to 85	CKV05	Samples
CDCVF2505DRG4	ACTIVE	SOIC	D	8	2500	RoHS & Green	NIPDAU	Level-1-260C-UNLIM	-40 to 85	CKV05	Samples
CDCVF2505PW	ACTIVE	TSSOP	PW	8	150	RoHS & Green	NIPDAU	Level-1-260C-UNLIM	-40 to 85	CKV05	Samples
CDCVF2505PWR	ACTIVE	TSSOP	PW	8	2000	RoHS & Green	NIPDAU	Level-1-260C-UNLIM	-40 to 85	CKV05	Samples
CDCVF2505PWRG4	ACTIVE	TSSOP	PW	8	2000	RoHS & Green	NIPDAU	Level-1-260C-UNLIM	-40 to 85	CKV05	Samples
HPA00771PWR	ACTIVE	TSSOP	PW	8	2000	RoHS & Green	NIPDAU	Level-1-260C-UNLIM	-40 to 85	CKV05	Samples

(1) The marketing status values are defined as follows:

ACTIVE: Product device recommended for new designs.

LIFEBUY: TI has announced that the device will be discontinued, and a lifetime-buy period is in effect.

NRND: Not recommended for new designs. Device is in production to support existing customers, but TI does not recommend using this part in a new design.

PREVIEW: Device has been announced but is not in production. Samples may or may not be available.

OBSOLETE: TI has discontinued the production of the device.

(2) **RoHS:** TI defines "RoHS" to mean semiconductor products that are compliant with the current EU RoHS requirements for all 10 RoHS substances, including the requirement that RoHS substance do not exceed 0.1% by weight in homogeneous materials. Where designed to be soldered at high temperatures, "RoHS" products are suitable for use in specified lead-free processes. TI may reference these types of products as "Pb-Free".

RoHS Exempt: TI defines "RoHS Exempt" to mean products that contain lead but are compliant with EU RoHS pursuant to a specific EU RoHS exemption.

Green: TI defines "Green" to mean the content of Chlorine (Cl) and Bromine (Br) based flame retardants meet JS709B low halogen requirements of <=1000ppm threshold. Antimony trioxide based flame retardants must also meet the <=1000ppm threshold requirement.

(3) MSL, Peak Temp. - The Moisture Sensitivity Level rating according to the JEDEC industry standard classifications, and peak solder temperature.

(4) There may be additional marking, which relates to the logo, the lot trace code information, or the environmental category on the device.

(5) Multiple Device Markings will be inside parentheses. Only one Device Marking contained in parentheses and separated by a "~" will appear on a device. If a line is indented then it is a continuation of the previous line and the two combined represent the entire Device Marking for that device.

⁽⁶⁾ Lead finish/Ball material - Orderable Devices may have multiple material finish options. Finish options are separated by a vertical ruled line. Lead finish/Ball material values may wrap to two lines if the finish value exceeds the maximum column width.

Important Information and Disclaimer:The information provided on this page represents TI's knowledge and belief as of the date that it is provided. TI bases its knowledge and belief on information provided by third parties, and makes no representation or warranty as to the accuracy of such information. Efforts are underway to better integrate information from third parties. TI has taken and continues to take reasonable steps to provide representative and accurate information but may not have conducted destructive testing or chemical analysis on incoming materials and chemicals. TI and TI suppliers consider certain information to be proprietary, and thus CAS numbers and other limited information may not be available for release.

In no event shall TI's liability arising out of such information exceed the total purchase price of the TI part(s) at issue in this document sold by TI to Customer on an annual basis.

OTHER QUALIFIED VERSIONS OF CDCVF2505 :

- Automotive: [CDCVF2505-Q1](#)

NOTE: Qualified Version Definitions:

- Automotive - Q100 devices qualified for high-reliability automotive applications targeting zero defects

TAPE AND REEL INFORMATION

QUADRANT ASSIGNMENTS FOR PIN 1 ORIENTATION IN TAPE



*All dimensions are nominal

Device	Package Type	Package Drawing	Pins	SPQ	Reel Diameter (mm)	Reel Width W1 (mm)	A0 (mm)	B0 (mm)	K0 (mm)	P1 (mm)	W (mm)	Pin1 Quadrant
CDCVF2505DR	SOIC	D	8	2500	330.0	12.4	6.4	5.2	2.1	8.0	12.0	Q1
CDCVF2505PWR	TSSOP	PW	8	2000	330.0	12.4	7.0	3.6	1.6	8.0	12.0	Q1

TAPE AND REEL BOX DIMENSIONS

*All dimensions are nominal

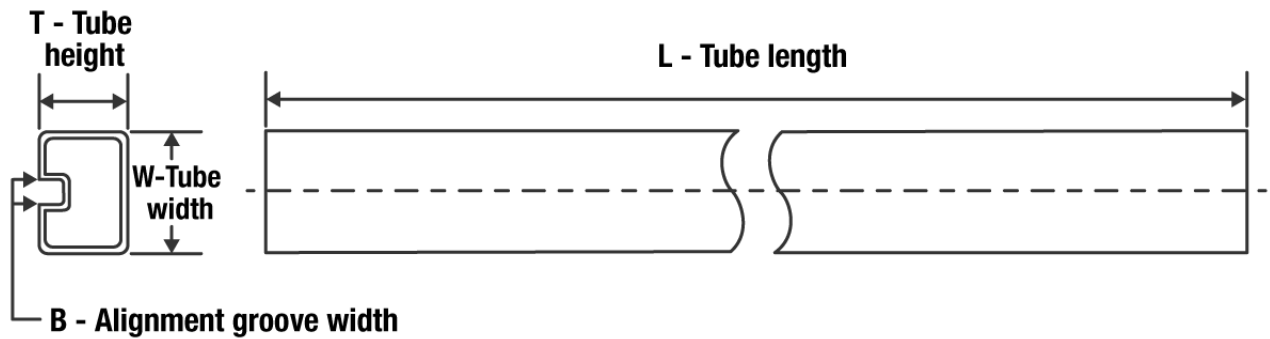
Device	Package Type	Package Drawing	Pins	SPQ	Length (mm)	Width (mm)	Height (mm)
CDCVF2505DR	SOIC	D	8	2500	350.0	350.0	43.0
CDCVF2505PWR	TSSOP	PW	8	2000	853.0	449.0	35.0

TUBE

*All dimensions are nominal

Device	Package Name	Package Type	Pins	SPQ	L (mm)	W (mm)	T (μm)	B (mm)
CDCVF2505D	D	SOIC	8	75	505.46	6.76	3810	4
CDCVF2505DG4	D	SOIC	8	75	505.46	6.76	3810	4
CDCVF2505PW	PW	TSSOP	8	150	530	10.2	3600	3.5



D0008A

PACKAGE OUTLINE

SOIC - 1.75 mm max height

SMALL OUTLINE INTEGRATED CIRCUIT



4214825/C 02/2019

NOTES:

1. Linear dimensions are in inches [millimeters]. Dimensions in parenthesis are for reference only. Controlling dimensions are in inches. Dimensioning and tolerancing per ASME Y14.5M.
2. This drawing is subject to change without notice.
3. This dimension does not include mold flash, protrusions, or gate burrs. Mold flash, protrusions, or gate burrs shall not exceed $.006$ [0.15] per side.
4. This dimension does not include interlead flash.
5. Reference JEDEC registration MS-012, variation AA.

EXAMPLE BOARD LAYOUT

D0008A

SOIC - 1.75 mm max height

SMALL OUTLINE INTEGRATED CIRCUIT



LAND PATTERN EXAMPLE
 EXPOSED METAL SHOWN
 SCALE:8X



SOLDER MASK DETAILS

4214825/C 02/2019

NOTES: (continued)

- 6. Publication IPC-7351 may have alternate designs.
- 7. Solder mask tolerances between and around signal pads can vary based on board fabrication site.

EXAMPLE STENCIL DESIGN

D0008A

SOIC - 1.75 mm max height

SMALL OUTLINE INTEGRATED CIRCUIT



SOLDER PASTE EXAMPLE
BASED ON .005 INCH [0.125 MM] THICK STENCIL
SCALE:8X

4214825/C 02/2019

NOTES: (continued)

8. Laser cutting apertures with trapezoidal walls and rounded corners may offer better paste release. IPC-7525 may have alternate design recommendations.
9. Board assembly site may have different recommendations for stencil design.

PW0008A



PACKAGE OUTLINE
TSSOP - 1.2 mm max height

SMALL OUTLINE PACKAGE



4221848/A 02/2015

NOTES:

1. All linear dimensions are in millimeters. Any dimensions in parenthesis are for reference only. Dimensioning and tolerancing per ASME Y14.5M.
2. This drawing is subject to change without notice.
3. This dimension does not include mold flash, protrusions, or gate burrs. Mold flash, protrusions, or gate burrs shall not exceed 0.15 mm per side.
4. This dimension does not include interlead flash. Interlead flash shall not exceed 0.25 mm per side.
5. Reference JEDEC registration MO-153, variation AA.

EXAMPLE BOARD LAYOUT

PW0008A

TSSOP - 1.2 mm max height

SMALL OUTLINE PACKAGE

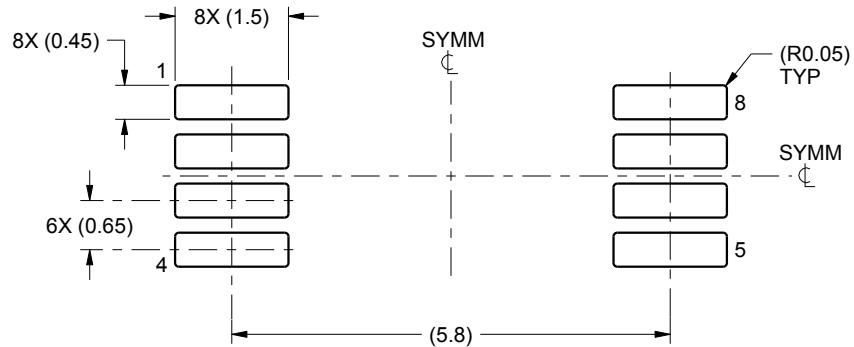

LAND PATTERN EXAMPLE
SCALE:10X

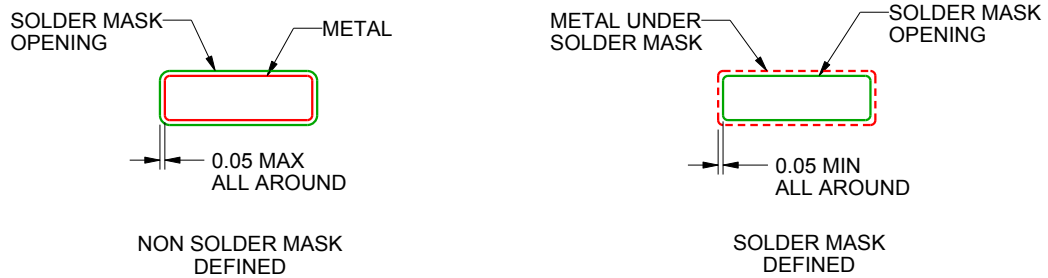

SOLDER MASK DETAILS
NOT TO SCALE

4221848/A 02/2015

NOTES: (continued)

- 6. Publication IPC-7351 may have alternate designs.
- 7. Solder mask tolerances between and around signal pads can vary based on board fabrication site.

EXAMPLE STENCIL DESIGN

PW0008A

TSSOP - 1.2 mm max height

SMALL OUTLINE PACKAGE



SOLDER PASTE EXAMPLE
BASED ON 0.125 mm THICK STENCIL
SCALE:10X

4221848/A 02/2015

NOTES: (continued)

8. Laser cutting apertures with trapezoidal walls and rounded corners may offer better paste release. IPC-7525 may have alternate design recommendations.
9. Board assembly site may have different recommendations for stencil design.

IMPORTANT NOTICE AND DISCLAIMER

TI PROVIDES TECHNICAL AND RELIABILITY DATA (INCLUDING DATA SHEETS), DESIGN RESOURCES (INCLUDING REFERENCE DESIGNS), APPLICATION OR OTHER DESIGN ADVICE, WEB TOOLS, SAFETY INFORMATION, AND OTHER RESOURCES "AS IS" AND WITH ALL FAULTS, AND DISCLAIMS ALL WARRANTIES, EXPRESS AND IMPLIED, INCLUDING WITHOUT LIMITATION ANY IMPLIED WARRANTIES OF MERCHANTABILITY, FITNESS FOR A PARTICULAR PURPOSE OR NON-INFRINGEMENT OF THIRD PARTY INTELLECTUAL PROPERTY RIGHTS.

These resources are intended for skilled developers designing with TI products. You are solely responsible for (1) selecting the appropriate TI products for your application, (2) designing, validating and testing your application, and (3) ensuring your application meets applicable standards, and any other safety, security, regulatory or other requirements.

These resources are subject to change without notice. TI grants you permission to use these resources only for development of an application that uses the TI products described in the resource. Other reproduction and display of these resources is prohibited. No license is granted to any other TI intellectual property right or to any third party intellectual property right. TI disclaims responsibility for, and you will fully indemnify TI and its representatives against, any claims, damages, costs, losses, and liabilities arising out of your use of these resources.

TI's products are provided subject to [TI's Terms of Sale](#) or other applicable terms available either on ti.com or provided in conjunction with such TI products. TI's provision of these resources does not expand or otherwise alter TI's applicable warranties or warranty disclaimers for TI products.

TI objects to and rejects any additional or different terms you may have proposed.

Mailing Address: Texas Instruments, Post Office Box 655303, Dallas, Texas 75265
Copyright © 2022, Texas Instruments Incorporated