



## 3.3 V RS-485 TRANSCEIVERS

### FEATURES

- **Controlled Baseline**
  - One Assembly/Test Site
  - One Fabrication Site
- **Extended Temperature Performance of Up to –40°C to 125°C and –55°C to 125°C**
- **Enhanced Diminishing Manufacturing Sources (DMS) Support**
- **Enhanced Product-Change Notification**
- **Qualification Pedigree <sup>(1)</sup>**
- **Operates With a 3.3 V Supply**
- **Bus-Pin ESD Protection Exceeds 16 kV HBM**
- **1/8 Unit-Load Option Available (Up to 256 Nodes on the Bus)**
- **Optional Driver Output Transition Times for Signaling Rates of 1 Mbps, 10 Mbps, and 25 Mbps <sup>(2)</sup>**
- **Meets or Exceeds the Requirements of ANSI TIA/EIA-485-A**
- **Bus-Pin Short Circuit Protection From –7 V to 12 V**
- **Low-Current Standby Mode . . . 1  $\mu$ A (Typ)**
- **Open-Circuit, Idle-Bus, and Shorted-Bus Failsafe Receiver**
- **Thermal Shutdown Protection**
- **Glitch-Free Power-Up and Power-Down Protection for Hot-Plugging Applications**
- **SN75176 Footprint**

- (1) Component qualification in accordance with JEDEC and industry standards to ensure reliable operation over an extended temperature range. This includes, but is not limited to, Highly Accelerated Stress Test (HAST) or biased 85/85, temperature cycle, autoclave or unbiased HAST, electromigration, bond intermetallic life, and mold compound life. Such qualification testing should not be viewed as justifying use of this component beyond specified performance and environmental limits.
- (2) The signaling rate of a line is the number of voltage transitions that are made per second expressed in the units bps (bits per second).

### APPLICATIONS

- **Digital Motor Control**
- **Utility Meters**
- **Chassis-to-Chassis Interconnects**
- **Electronic Security Stations**
- **Industrial Process Control**
- **Building Automation**
- **Point-of-Sale (POS) Terminals and Networks**

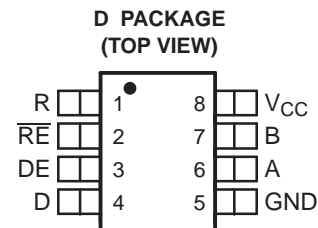

### DESCRIPTION/ORDERING INFORMATION

The SN65HVD10, SN65HVD11, and SN65HVD12 combine a 3-state differential line driver and differential input line receiver that operate with a single 3.3 V power supply. They are designed for balanced transmission lines and meet or exceed ANSI standard TIA/EIA-485-A and ISO 8482:1993. These differential bus transceivers are monolithic integrated circuits designed for bidirectional data communication on multipoint bus-transmission lines. The drivers and receivers have active-high and active-low enables respectively, that can be externally connected together to function as direction control. Low device standby supply current can be achieved by disabling the driver and the receiver.

The driver differential outputs and receiver differential inputs connect internally to form a differential input/output (I/O) bus port that is designed to offer minimum loading to the bus whenever the driver is disabled or  $V_{CC} = 0$ . These parts feature wide positive and negative common-mode voltage ranges, making them suitable for party-line applications.



Please be aware that an important notice concerning availability, standard warranty, and use in critical applications of Texas Instruments semiconductor products and disclaimers thereto appears at the end of this data sheet.



These devices have limited built-in ESD protection. The leads should be shorted together or the device placed in conductive foam during storage or handling to prevent electrostatic damage to the MOS gates.

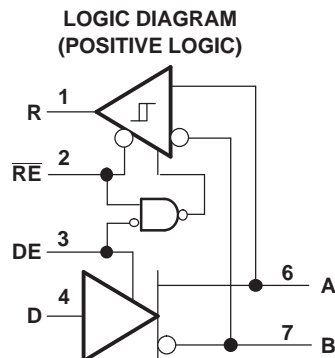

**ORDERING INFORMATION<sup>(1)</sup>**

SIGNALING RATE	UNIT LOADS	T <sub>A</sub>	PACKAGE SOIC <sup>(2)(3)</sup>	SOIC MARKING
25 Mbps	1/2	–40°C to 125°C	SN65HVD10QDREP	V10QEP
10 Mbps	1/8		SN65HVD11QDREP <sup>(4)</sup>	V11QEP
1 Mbps	1/8	–40°C to 85°C	SN65HVD12IDREP	V12IEP
25 Mbps	1/2	–55°C to 125°C	SN65HVD10MDREP	V10MEP

- (1) For the most current package and ordering information, see the Package Option Addendum at the end of this document, or see the TI Web site at [www.ti.com](http://www.ti.com).
- (2) Package drawings, thermal data, and symbolization are available at [www.ti.com/packaging](http://www.ti.com/packaging).
- (3) The D package is taped and reeled as indicated by the R suffix to the part number (i.e., SN65HVD10QDREP).
- (4) Product Preview

**ABSOLUTE MAXIMUM RATINGS<sup>(1)(2)</sup>**

over operating free-air temperature range (unless otherwise noted)

			SN65HVD10-EP SN65HVD11-EP SN65HVD12-EP
Supply voltage range, V <sub>CC</sub>			–0.3 V to 6 V
Voltage range at A or B			–9 V to 14 V
Input voltage range at D, DE, R, or RE			–0.5 V to V <sub>CC</sub> + 0.5 V
Voltage input range, transient pulse, A and B, through 100 Ω (see Figure 11)			–50 V to 50 V
Electrostatic discharge	Human body model <sup>(3)</sup>	A, B, and GND	16 kV
		All pins	4 kV
	Charged-device model <sup>(4)</sup>	All pins Charge	1 kV
Continuous total power dissipation			See Package Dissipation Rating Table
Storage temperature range, T <sub>stg</sub>			–65°C to 150°C
Lead temperature 1,6 mm (1/16 in) from case for 10 s			260°C

- (1) Stresses beyond those listed under "absolute maximum ratings" may cause permanent damage to the device. These are stress ratings only, and functional operation of the device at these or any other conditions beyond those indicated under "recommended operating conditions" is not implied. Exposure to absolute-maximum-rated conditions for extended periods may affect device reliability.
- (2) All voltage values, except differential I/O bus voltages, are with respect to network ground terminal.
- (3) Tested in accordance with JEDEC Standard 22, Test Method A114-A.
- (4) Tested in accordance with JEDEC Standard 22, Test Method C101.

**PACKAGE DISSIPATION RATINGS**

PACKAGE	T <sub>A</sub> ≤ 25°C POWER RATING	DERATING FACTOR <sup>(1)</sup> ABOVE T <sub>A</sub> = 25°C	T <sub>A</sub> = 70°C POWER RATING	T <sub>A</sub> = 85°C POWER RATING	T <sub>A</sub> = 125°C POWER RATING
D <sup>(2)</sup>	597 mW	4.97 mW/°C	373 mW	298 mW	100 mW
D <sup>(3)</sup>	990 mW	8.26 mW/°C	620 mW	496 mW	165 mW

- (1) This is the inverse of the junction-to-ambient thermal resistance when board-mounted and with no air flow.
- (2) Tested in accordance with the Low-K thermal metric definitions of EIA/JESD51-3.
- (3) Tested in accordance with the High-K thermal metric definitions of EIA/JESD51-7.

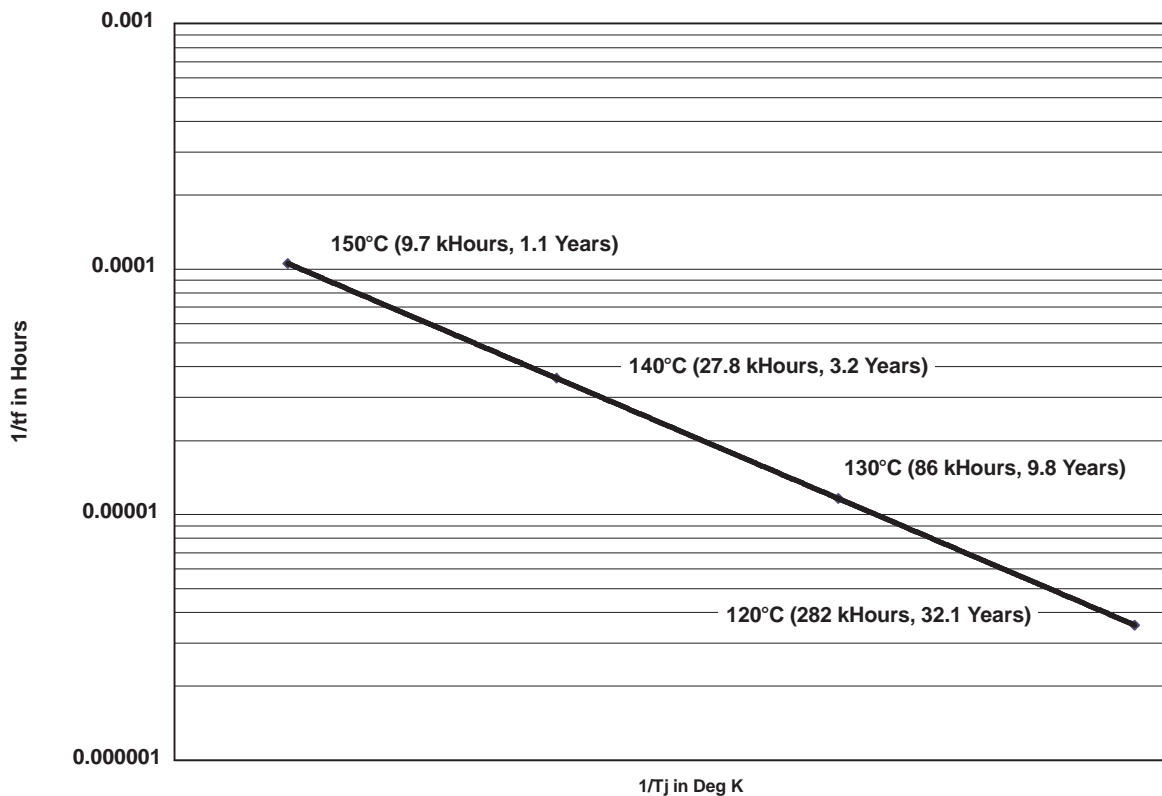

**Figure 1. Estimated Device Life Based Kirkendall Voiding Failure Mode**

**RECOMMENDED OPERATING CONDITIONS**

		MIN	NOM	MAX	UNIT
Supply voltage, $V_{CC}$		3		3.6	V
Voltage at any bus terminal (separately or common mode) $V_I$ or $V_{IC}$		-7 <sup>(1)</sup>		12	V
High-level input voltage, $V_{IH}$	D, DE, $\overline{RE}$	2		$V_{CC}$	V
Low-level input voltage, $V_{IL}$	D, DE, $\overline{RE}$	0		0.8	V
Differential input voltage, $V_{ID}$ (see <a href="#">Figure 8</a> )		-12		12	V
High-level output current, $I_{OH}$	Driver	-60			mA
	Receiver	-8			
Low-level output current, $I_{OL}$	Driver			60	mA
	Receiver			8	
Differential load resistance, $R_L$		54	60		$\Omega$
Differential load capacitance, $C_L$			50		pF
Signaling rate	HVD10			25	Mbps
	HVD11			10	
	HVD12			1	

(1) The algebraic convention, in which the least positive (most negative) limit is designated as minimum is used in this data sheet.

## DRIVER ELECTRICAL CHARACTERISTICS

over recommended operating free-air temperature range (unless otherwise noted)

PARAMETER		TEST CONDITIONS	MIN	TYP <sup>(1)</sup>	MAX	UNIT
$V_{IK}$	Input clamp voltage	$I_I = -18 \text{ mA}$	-1.5			V
$ V_{OD} $	Differential output voltage <sup>(2)</sup>	$I_O = 0$	2		$V_{CC}$	V
		$R_L = 54 \Omega$ , See <a href="#">Figure 2</a>	1.5			
		$V_{test} = -7 \text{ V to } 12 \text{ V}$ , See <a href="#">Figure 3</a>	1.5			
$\Delta V_{OD} $	Change in magnitude of differential output voltage	See <a href="#">Figure 2</a> and <a href="#">Figure 3</a>	-0.2		0.2	V
$V_{OC(PP)}$	Peak-to-peak common-mode output voltage	See <a href="#">Figure 4</a>		400		mV
$V_{OC(SS)}$	Steady-state common-mode output voltage		1.4		2.5	V
$\Delta V_{OC(SS)}$	Change in steady-state common-mode output voltage		-0.05		0.05	V
$I_{OZ}$	High-impedance output current	See receiver input currents				
$I_I$	Input current	D	-100		0	$\mu\text{A}$
		DE	0		100	
$I_{OS}$	Short-circuit output current	$-7 \text{ V} \leq V_O \leq 12 \text{ V}$	-250		250	mA
$C_{(OD)}$	Differential output capacitance	$V_{OD} = 0.4 \sin(4E6\pi t) + 0.5 \text{ V}$ , DE at 0 V		16		pF
$I_{CC}$	Supply current	$\overline{RE}$ at $V_{CC}$ , D and DE at $V_{CC}$ , No load	Receiver disabled and driver enabled	9	15.5	mA
		$\overline{RE}$ at $V_{CC}$ , D at $V_{CC}$ , DE at 0 V, No load	Receiver disabled and driver disabled (standby)	1	5	$\mu\text{A}$
		$\overline{RE}$ at 0 V, D and DE at $V_{CC}$ , No load	Receiver enabled and driver enabled	9	15.5	mA

(1) All typical values are at 25°C and with a 3.3 V supply.

 (2) For  $T_A > 85^\circ\text{C}$ ,  $V_{CC}$  is  $\pm 5\%$ .

## DRIVER SWITCHING CHARACTERISTICS

over recommended operating free-air temperature range (unless otherwise noted)

PARAMETER		TEST CONDITIONS	MIN	TYP <sup>(1)</sup>	MAX	UNIT
t <sub>PLH</sub>	Propagation delay time, low-to-high level output	HVD10	5	8.5	16	ns
		HVD11	18	25	40	
		HVD12	135	200	330	
t <sub>PHL</sub>	Propagation delay time, high-to-low level output	HVD10	5	8.5	16	ns
		HVD11	18	25	40	
		HVD12	135	200	330	
t <sub>r</sub>	Differential output signal rise time	HVD10	3	4.5	11.5	ns
		HVD11	10	20	30	
		HVD12	100	170	330	
t <sub>f</sub>	Differential output signal fall time	HVD10	3	4.5	11.5	ns
		HVD11	10	20	30	
		HVD12	100	170	330	
t <sub>sk(p)</sub>	Pulse skew ( t <sub>PHL</sub> - t <sub>PLH</sub>  )	HVD10			1.5	ns
		HVD11			2.5	
		HVD12			9	
t <sub>sk(pp)</sub> <sup>(2)</sup>	Part-to-part skew	HVD10			6	ns
		HVD11			11	
		HVD12			100	
t <sub>PZH</sub>	Propagation delay time, high impedance-to-high level output	HVD10			33	ns
		HVD11			55	
		HVD12			320	
t <sub>PHZ</sub>	Propagation delay time, high level-to-high-impedance output	HVD10			26	ns
		HVD11			55	
		HVD12			320	
t <sub>PZL</sub>	Propagation delay time, high impedance-to-low-level output	HVD10			26	ns
		HVD11			55	
		HVD12			320	
t <sub>PLZ</sub>	Propagation delay time, low level-to-high-impedance output	HVD10			26	ns
		HVD11			75	
		HVD12			420	
t <sub>PZH</sub>	Propagation delay time, standby-to-high-level output	I and Q-temp			6	μs
		M-temp			14	
t <sub>PZL</sub>	Propagation delay time, standby-to-low-level output	I and Q-temp			6	μs
		M-temp			14	

(1) All typical values are at 25°C and with a 3.3 V supply.

(2) t<sub>sk(pp)</sub> is the magnitude of the difference in propagation delay times between any specified terminals of two devices when both devices operate with the same supply voltages, at the same temperature, and have identical packages and test circuits.

## RECEIVER ELECTRICAL CHARACTERISTICS

over recommended operating free-air temperature range (unless otherwise noted)

PARAMETER		TEST CONDITIONS		MIN	TYP <sup>(1)</sup>	MAX	UNIT
$V_{IT+}$	Positive-going input threshold voltage	$I_O = -8$ mA				-0.01	V
$V_{IT-}$	Negative-going input threshold voltage	$I_O = 8$ mA		-0.2			V
$V_{hys}$	Hysteresis voltage ( $V_{IT+} - V_{IT-}$ )				35		mV
$V_{IK}$	Enable-input clamp voltage	$I_I = -18$ mA		-1.5			V
$V_{OH}$	High-level output voltage	$V_{ID} = 200$ mV,	$I_{OH} = -8$ mA,	See <a href="#">Figure 8</a>		2.4	V
$V_{OL}$	Low-level output voltage	$V_{ID} = -200$ mV,	$I_{OL} = 8$ mA,	See <a href="#">Figure 8</a>		0.4	V
$I_{OZ}$	High-impedance-state output current	$V_O = 0$ or $V_{CC}$	$\overline{RE}$ at $V_{CC}$	-1		1	$\mu$ A
$I_I$	Bus input current	$V_A$ or $V_B = 12$ V	HVD11, HVD12, Other input at 0 V		0.05	0.11	mA
		$V_A$ or $V_B = 12$ V, $V_{CC} = 0$ V			0.06	0.13	
		$V_A$ or $V_B = -7$ V			-0.1	-0.05	
		$V_A$ or $V_B = -7$ V, $V_{CC} = 0$ V			-0.05	+0.04	
		$V_A$ or $V_B = 12$ V	HVD10, Other input at 0 V		0.2	0.5	mA
		$V_A$ or $V_B = 12$ V, $V_{CC} = 0$ V			0.25	0.5	
		$V_A$ or $V_B = -7$ V			-0.4	-0.2	
		$V_A$ or $V_B = -7$ V, $V_{CC} = 0$ V			-0.4	-0.15	
$I_{IH}$	High-level input current, $\overline{RE}$	$V_{IH} = 2$ V		-30		0	$\mu$ A
$I_{IL}$	Low-level input current, $\overline{RE}$	$V_{IL} = 0.8$ V		-30		0	$\mu$ A
$C_{ID}$	Differential input capacitance	$V_{ID} = 0.4 \sin(4E6\pi t) + 0.5$ V, DE at 0 V			15		pF
$I_{CC}$	Supply current	$\overline{RE}$ at 0 V, D and DE at 0 V, No load	Receiver enabled and driver disabled		4	8	mA
		$\overline{RE}$ at $V_{CC}$ , D at $V_{CC}$ , DE at 0 V, No load	Receiver disabled and driver disabled (standby)		1	5	$\mu$ A
		$\overline{RE}$ at 0 V, D and DE at $V_{CC}$ , No load	Receiver enabled and driver enabled		9	15.5	mA

(1) All typical values are at 25°C and with a 3.3 V supply.

## RECEIVER SWITCHING CHARACTERISTICS

over recommended operating free-air temperature range (unless otherwise noted)

PARAMETER		TEST CONDITIONS	MIN	TYP <sup>(1)</sup>	MAX	UNIT
t <sub>PLH</sub>	Propagation delay time, low-to-high level output	HVD10	12.5	20	25	ns
t <sub>PHL</sub>	Propagation delay time, high-to-low level output	HVD10	12.5	20	25	ns
t <sub>PLH</sub>	Propagation delay time, low-to-high level output	HVD11 HVD12	30	55	70	ns
t <sub>PHL</sub>	Propagation delay time, high-to-low level output	HVD11 HVD12	30	55	70	ns
t <sub>sk(p)</sub>	Pulse skew ( t <sub>PHL</sub> - t <sub>PLH</sub>  )	HVD10			1.5	ns
		HVD11			4	
		HVD12			4	
t <sub>sk(pp)</sub> <sup>(2)</sup>	Part-to-part skew	HVD10			8	ns
		HVD11			15	
		HVD12			15	
t <sub>r</sub>	Output signal rise time	C <sub>L</sub> = 15 pF, See Figure 9	1	2	6	ns
t <sub>f</sub>	Output signal fall time		1	2	6	
t <sub>PZH</sub> <sup>(1)</sup>	Output enable time to high level	C <sub>L</sub> = 15 pF, DE at 3 V, See Figure 10			16	ns
t <sub>PZL</sub> <sup>(1)</sup>	Output enable time to low level				16	
t <sub>PHZ</sub>	Output disable time from high level				21	
t <sub>PLZ</sub>	Output disable time from low level				16	
t <sub>PZH</sub> <sup>(2)</sup>	Propagation delay time, standby-to-high-level output	I and Q-temp			6	μs
		M-temp			14	
t <sub>PZL</sub> <sup>(2)</sup>	Propagation delay time, standby-to-low-level output	I and Q-temp			6	
		M-temp			14	

(1) All typical values are at 25°C and with a 3.3 V supply.

(2) t<sub>sk(pp)</sub> is the magnitude of the difference in propagation delay times between any specified terminals of two devices when both devices operate with the same supply voltages, at the same temperature, and have identical packages and test circuits.

## THERMAL CHARACTERISTICS<sup>(1)</sup>

over operating free-air temperature range (unless otherwise noted)

PARAMETER		TEST CONDITIONS		MIN	TYP	MAX	UNIT
θ <sub>JA</sub>	Junction-to-ambient thermal resistance <sup>(2)</sup>	High-K board <sup>(3)</sup> , No airflow	D package		121		°C/W
θ <sub>JB</sub>	Junction-to-board thermal resistance	High-K board	D package		67		°C/W
θ <sub>JC</sub>	Junction-to-case thermal resistance		D package		41		°C/W
P <sub>D</sub>	Device power dissipation	R <sub>L</sub> = 60 Ω, C <sub>L</sub> = 50 pF, DE at V <sub>CC</sub> RE at 0 V, Input to D a 50% duty cycle square wave at indicated signaling rate	HVD10 (25 Mbps)		198	233	mW
			HVD11 (10 Mbps)		141	176	mW
			HVD12 (500 kbps)		133	161	mW
T <sub>JSD</sub>	Thermal shutdown junction temperature				165		°C

(1) See *Application Information* section for an explanation of these parameters.

(2) The intent of θ<sub>JA</sub> specification is solely for a thermal performance comparison of one package to another in a standardized environment. This methodology is not meant to and will not predict the performance of a package in an application-specific environment.

(3) JSD51-7, High Effective Thermal Conductivity Test Board for Leaded Surface Mount Packages.

PARAMETER MEASUREMENT INFORMATION

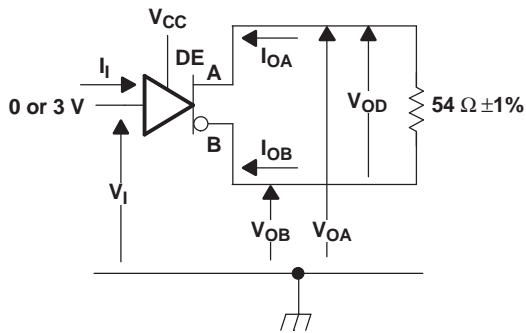

Figure 2. Driver  $V_{OD}$  Test Circuit and Voltage and Current Definitions

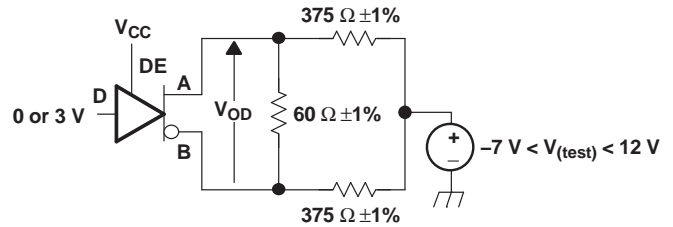
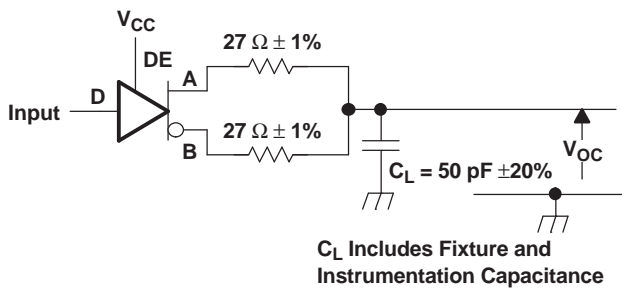
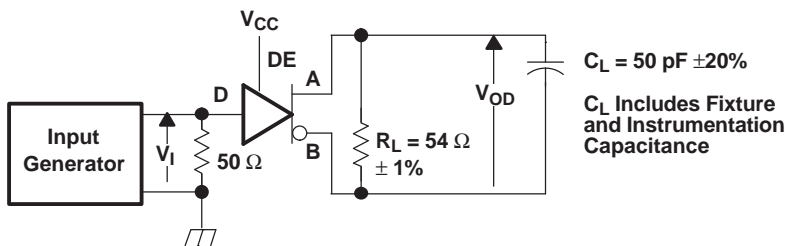
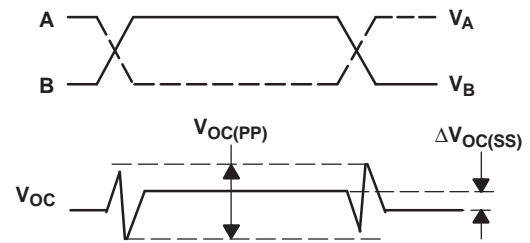

Figure 3. Driver  $V_{OD}$  With Common-Mode Loading Test Circuit



Input: PRR = 500 kHz, 50% Duty Cycle,  $t_r < 6$  ns,  $t_f < 6$  ns,  $Z_O = 50 \Omega$

Figure 4. Test Circuit and Definitions for the Driver Common-Mode Output Voltage



Generator: PRR = 500 kHz, 50% Duty Cycle,  $t_r < 6$  ns,  $t_f < 6$  ns,  $Z_O = 50 \Omega$

Figure 5. Driver Switching Test Circuit and Voltage Waveforms

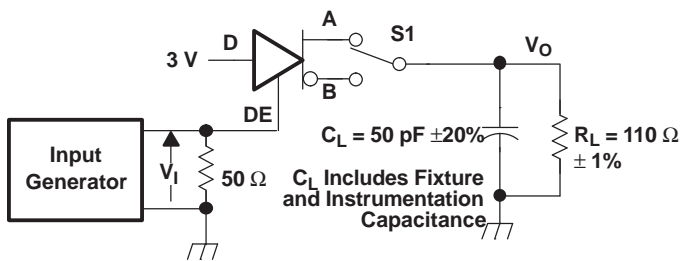
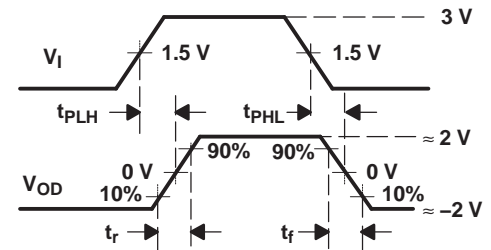

Generator: PRR = 500 kHz, 50% Duty Cycle,  $t_r < 6$  ns,  $t_f < 6$  ns,  $Z_O = 50 \Omega$

Figure 6. Driver High-Level Enable and Disable Time Test Circuit and Voltage Waveforms

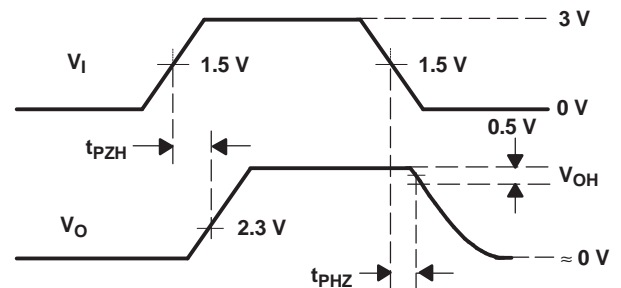

PARAMETER MEASUREMENT INFORMATION (continued)

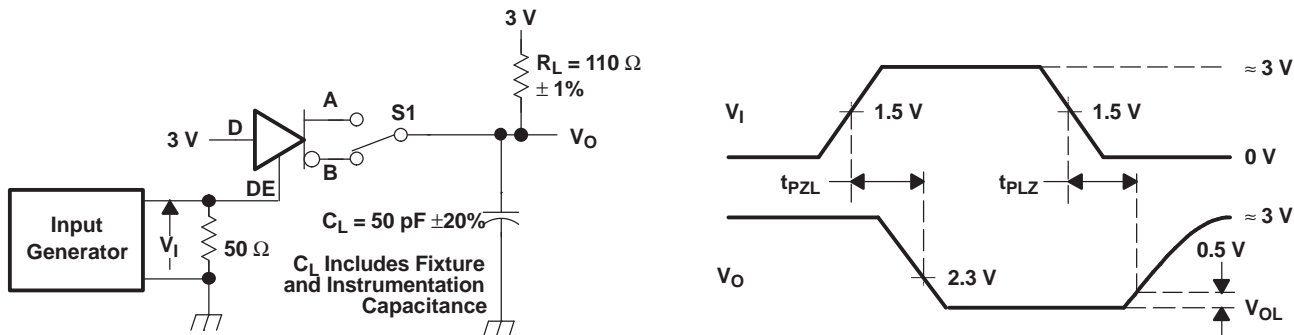

Generator: PRR = 500 kHz, 50% Duty Cycle,  $t_r < 6$  ns,  $t_f < 6$  ns,  $Z_o = 50 \Omega$

Figure 7. Driver Low-Level Output Enable and Disable Time Test Circuit and Voltage Waveforms

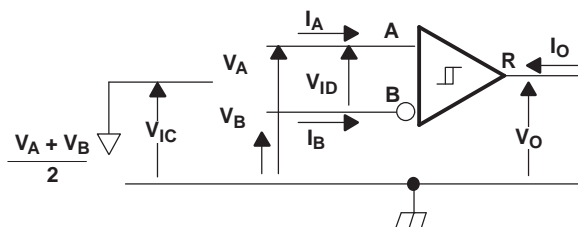
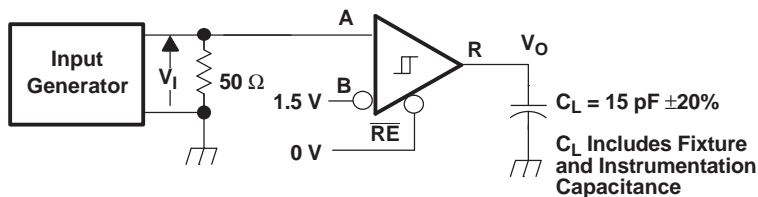

Figure 8. Receiver Voltage and Current Definitions



Generator: PRR = 500 kHz, 50% Duty Cycle,  $t_r < 6$  ns,  $t_f < 6$  ns,  $Z_o = 50 \Omega$

Figure 9. Receiver Switching Test Circuit and Voltage Waveforms

PARAMETER MEASUREMENT INFORMATION (continued)

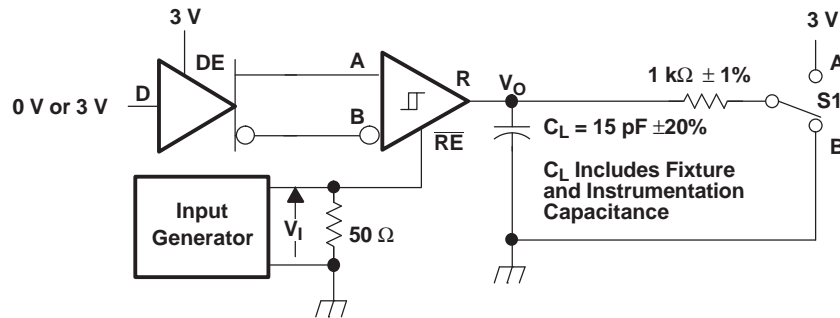

Generator: PRR = 500 kHz, 50% Duty Cycle,  $t_r < 6$  ns,  $t_f < 6$  ns,  $Z_o = 50 \Omega$

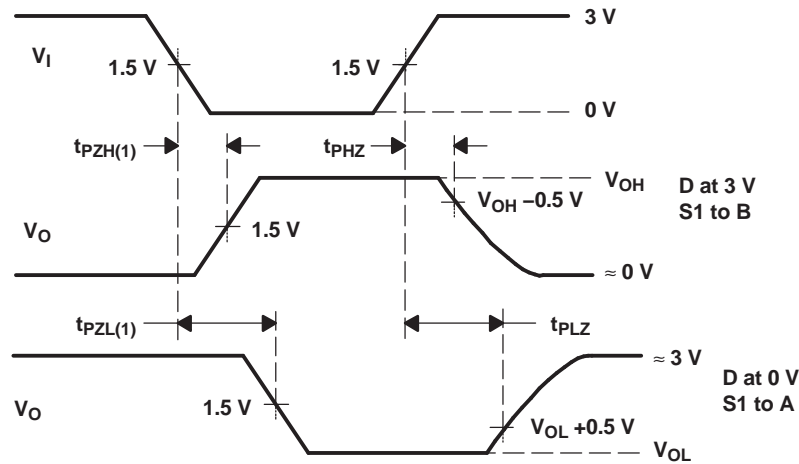

Figure 10. Receiver Enable and Disable Time Test Circuit and Voltage Waveforms With Drivers Enabled

PARAMETER MEASUREMENT INFORMATION (continued)

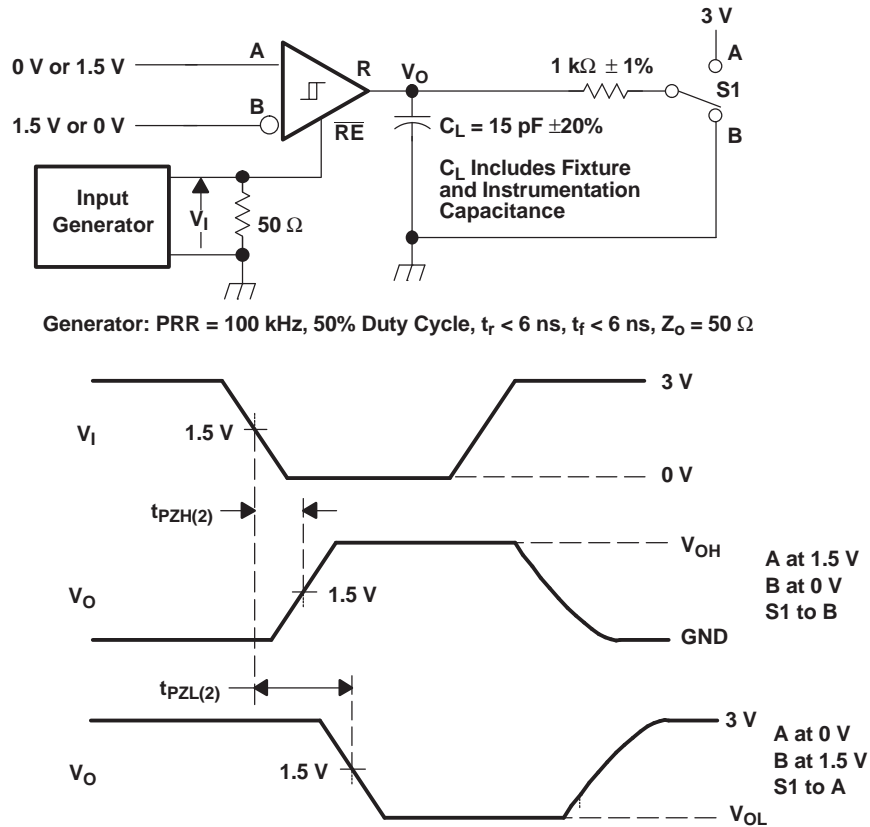
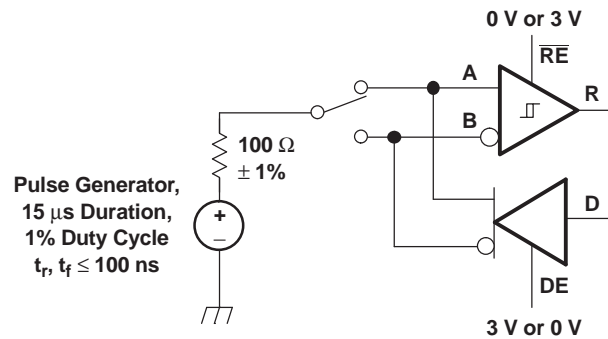

Figure 11. Receiver Enable Time From Standby (Driver Disabled)



NOTE: This test is conducted to test survivability only. Data stability at the R output is not specified.

Figure 12. Test Circuit, Transient Over Voltage Test

**Function Tables**

**DRIVER**

INPUT D	ENABLE DE	OUTPUTS	
		A	B
H	H	H	L
L	H	L	H
X	L	Z	Z
Open	H	H	L

**RECEIVER**

DIFFERENTIAL INPUTS $V_{ID} = V_A - V_B$	ENABLE $\overline{RE}$	OUTPUT R
$V_{ID} \leq -0.2\text{ V}$	L	L
$-0.2\text{ V} < V_{ID} < -0.01\text{ V}$	L	?
$-0.01\text{ V} \leq V_{ID}$	L	H
X	H	Z
Open Circuit	L	H
Short Circuit	L	H

EQUIVALENT INPUT AND OUTPUT SCHEMATIC DIAGRAMS

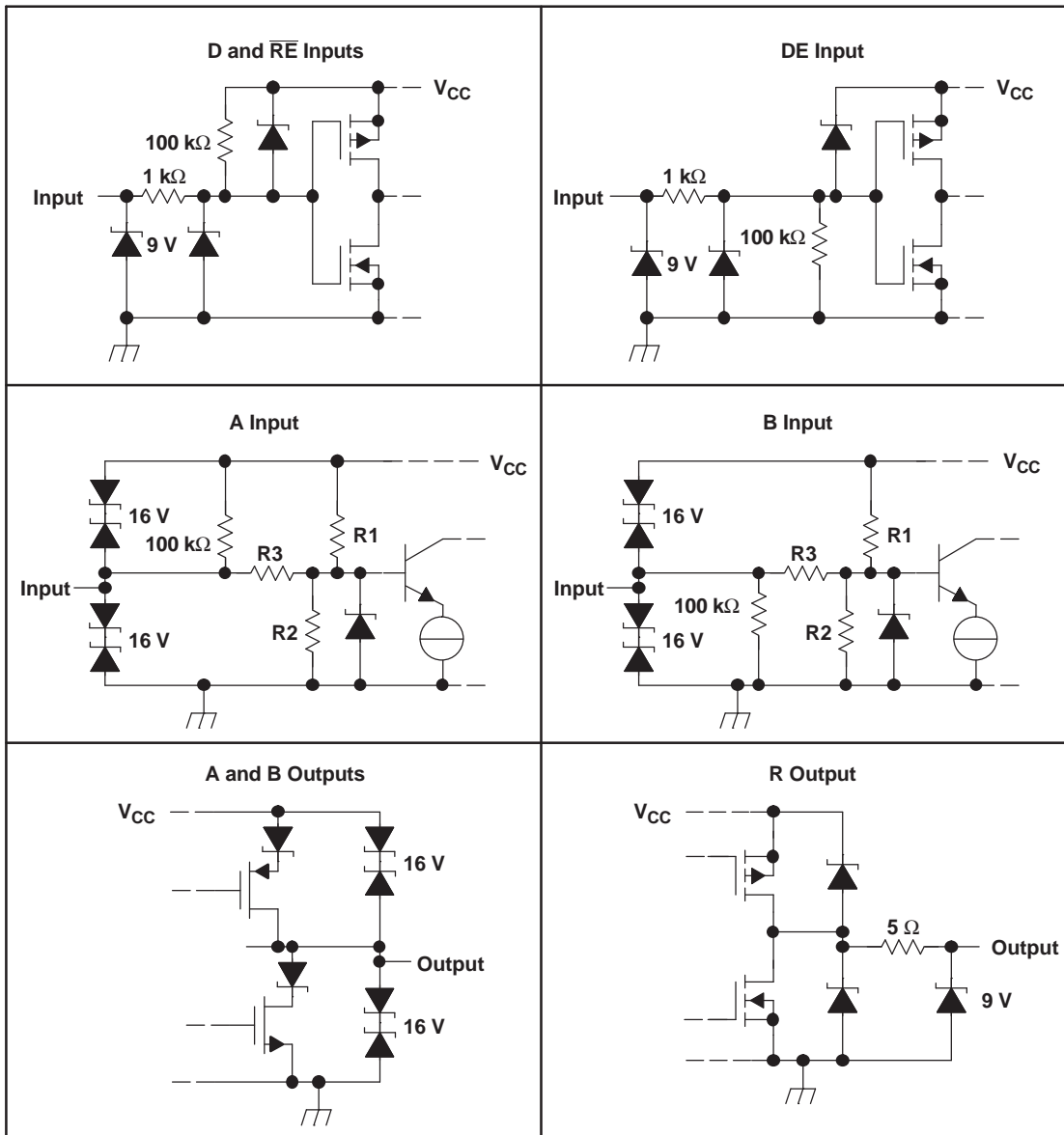

	R1/R2	R3
SN65HVD10	9 kΩ	45 kΩ
SN65HVD11	36 kΩ	180 kΩ
SN65HVD12	36 kΩ	180 kΩ

**TYPICAL CHARACTERISTICS**

**HVD10 OR HVD12**  
**RMS SUPPLY CURRENT**  
**VS**  
**SIGNALING RATE**

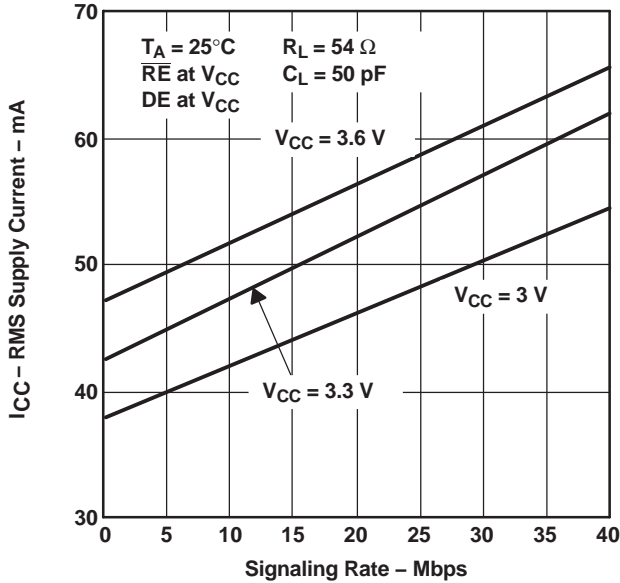

**Figure 13.**

**HVD11**  
**RMS SUPPLY CURRENT**  
**VS**  
**SIGNALING RATE**

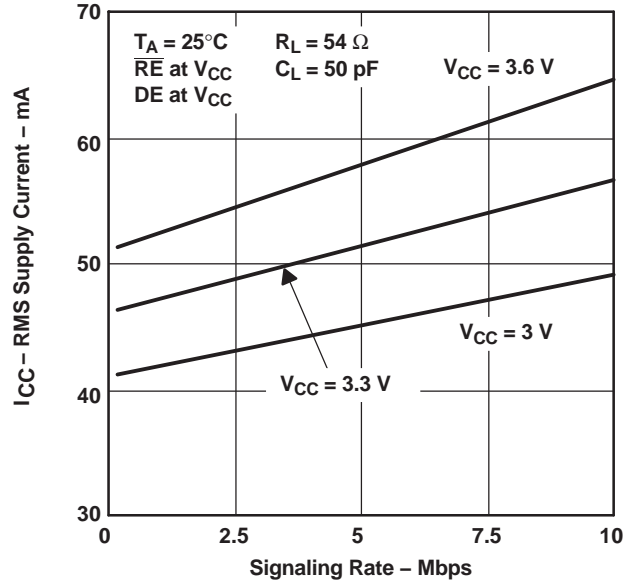

**Figure 14.**

**HVD12**  
**RMS SUPPLY CURRENT**  
**VS**  
**SIGNALING RATE**

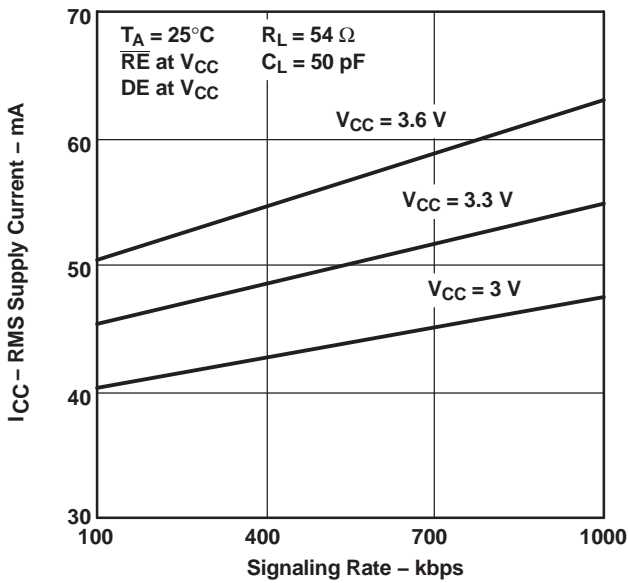

**Figure 15.**

**HVD10**  
**BUS INPUT CURRENT**  
**VS**  
**BUS INPUT VOLTAGE**

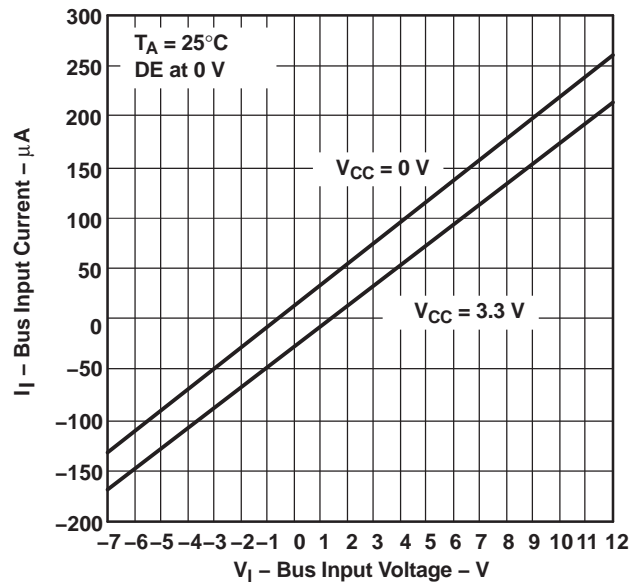

**Figure 16.**

TYPICAL CHARACTERISTICS (continued)

HVD11 OR HVD12  
BUS INPUT CURRENT  
vs  
BUS INPUT VOLTAGE

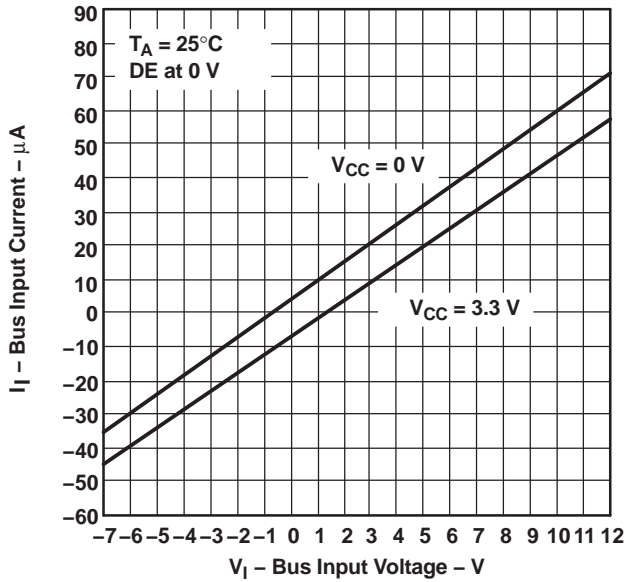

Figure 17.

HIGH-LEVEL OUTPUT CURRENT  
vs  
DRIVER HIGH-LEVEL OUTPUT VOLTAGE

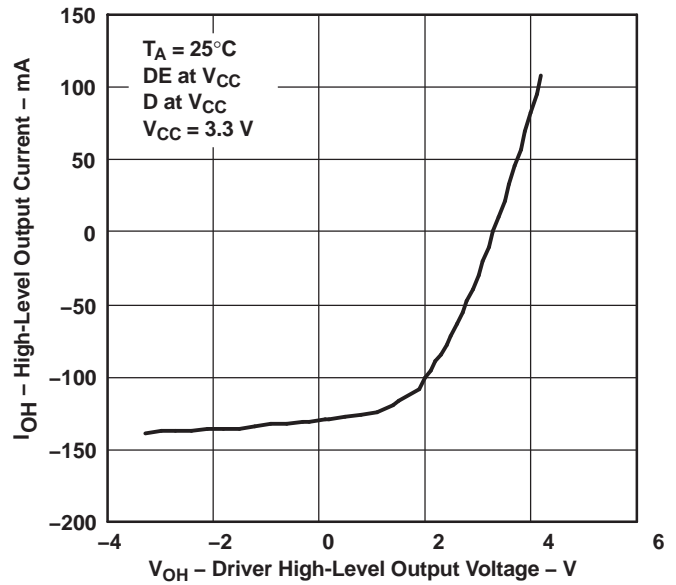

Figure 18.

LOW-LEVEL OUTPUT CURRENT  
vs

DRIVER LOW-LEVEL OUTPUT VOLTAGE

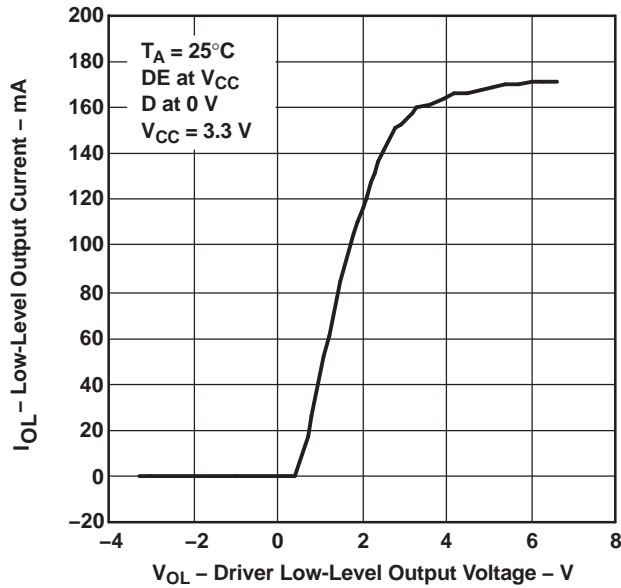

Figure 19.

DRIVER DIFFERENTIAL OUTPUT  
vs

FREE-AIR TEMPERATURE

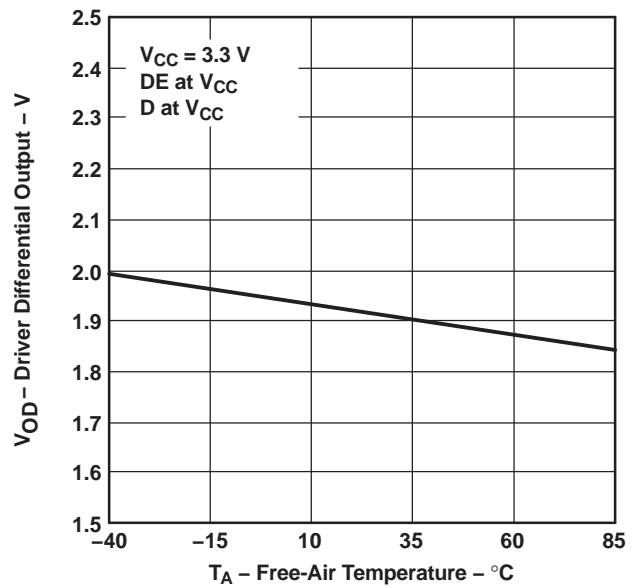
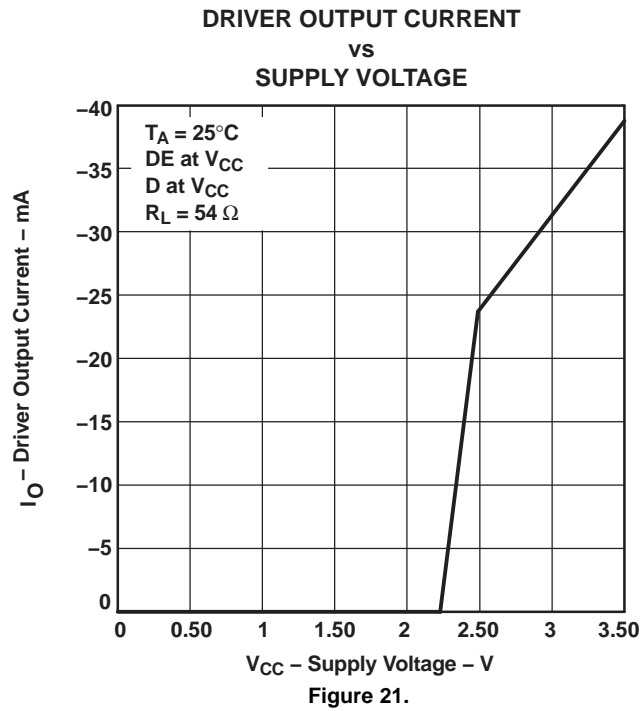

Figure 20.

TYPICAL CHARACTERISTICS (continued)



### APPLICATION INFORMATION

An example application for the HVD12 is illustrated in Figure 22. Two HVD12 transceivers are used to communicate data through a 2000 foot (600 m) length of Commscope 5524 category 5e+ twisted pair cable. The bus is terminated at each end by a 100 Ω resistor, matching the cable characteristic impedance. Figure 23 illustrates operation at a signaling rate of 250 kbps.

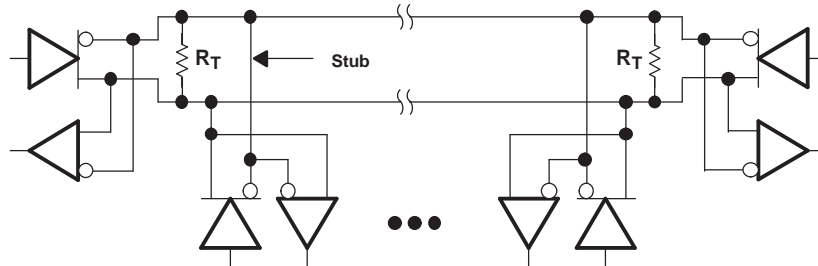

Device	Number of Devices on Bus
HVD10	64
HVD11	256
HVD12	256

NOTE: The line should be terminated at both ends with its characteristic impedance ( $R_T = Z_0$ ). Stub lengths off the main line should be kept as short as possible.

Figure 22. Typical Application Circuit

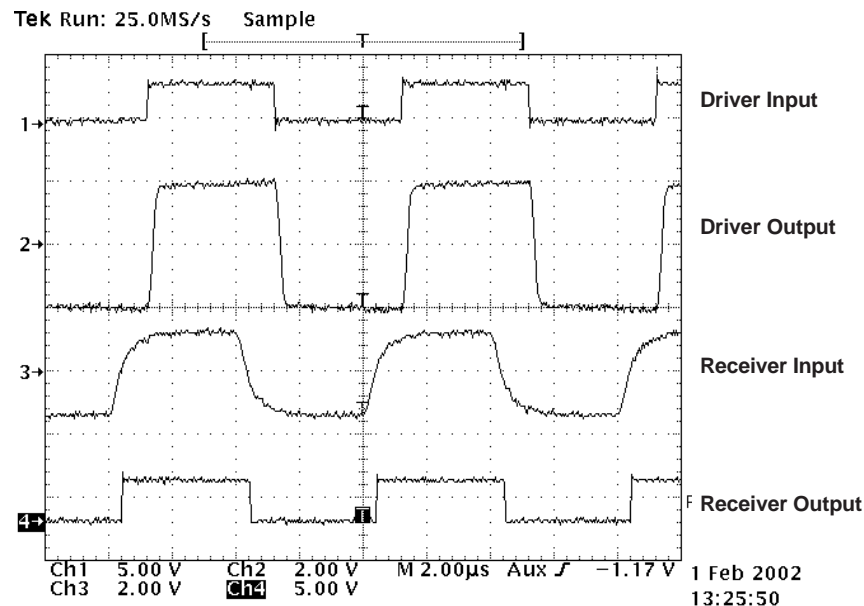

Figure 23. HVD12 Input and Output Through 2000 Feet of Cable

## THERMAL CHARACTERISTICS OF IC PACKAGES

**Junction-to-Ambient Thermal Resistance ( $\theta_{JA}$ )** is defined as the difference in junction temperature to ambient temperature divided by the operating power.

$\theta_{JA}$  is *not* a constant and is a strong function of:

- the PCB design (50% variation)
- altitude (20% variation)
- device power (5% variation)

$\theta_{JA}$  can be used to compare the thermal performance of packages if the specific test conditions are defined and used. Standardized testing includes specification of PCB construction, test chamber volume, sensor locations, and the thermal characteristics of holding fixtures.  $\theta_{JA}$  is often misused when it is used to calculate junction temperatures for other installations.

Texas Instruments uses two test PCBs as defined by JEDEC specifications. The low-k board gives *average* in-use condition thermal performance and consists of a single copper trace layer 25 mm long and 2 oz thick. The high-k board gives *best case* in-use condition and it consists of two 1 oz buried power planes with a single copper trace layer 25 mm long and 2 oz thick. A 4% to 50% difference in  $\theta_{JA}$  can be measured between these two test cards

**Junction-to-Case Thermal Resistance ( $\theta_{JC}$ )** is defined as difference in junction temperature to case divided by the operating power. It is measured by putting the mounted package up against a copper block cold plate to force heat to flow from die, through the mold compound into the copper block.

$\theta_{JC}$  is a useful thermal characteristic when a heatsink is applied to package. It is *not* a useful characteristic to predict junction temperature because it provides pessimistic numbers if the case temperature is measured in a nonstandard system and junction temperatures are backed out. It can be used with  $\theta_{JB}$  in one-dimensional thermal simulation of a package system.

**Junction-to-Board Thermal Resistance ( $\theta_{JB}$ )** is defined as the difference in the junction temperature and the PCB temperature at the center of the package (closest to the die) when the PCB is clamped in a cold-plate structure.  $\theta_{JB}$  is defined only for the high-k test card.

$\theta_{JB}$  provides an overall thermal resistance between the die and the PCB. It includes a bit of the PCB thermal resistance (especially for BGAs with thermal balls) and can be used for simple one-dimensional network analysis of the package system (see [Figure 24](#)).

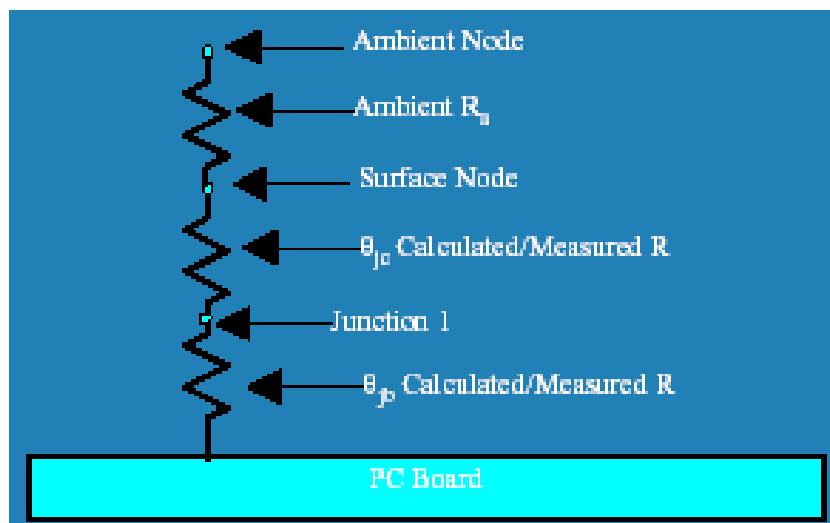

Figure 24. Thermal Resistance

## PACKAGING INFORMATION

Orderable Device	Status (1)	Package Type	Package Drawing	Pins	Package Qty	Eco Plan (2)	Lead finish/ Ball material (6)	MSL Peak Temp (3)	Op Temp (°C)	Device Marking (4/5)	Samples
SN65HVD10MDREP	ACTIVE	SOIC	D	8	2500	RoHS & Green	NIPDAU	Level-1-260C-UNLIM	-55 to 125	V10MEP	<a href="#">Samples</a>
SN65HVD10QDREP	ACTIVE	SOIC	D	8	2500	RoHS & Green	NIPDAU	Level-1-260C-UNLIM	-40 to 125	V10QEP	<a href="#">Samples</a>
SN65HVD12IDREP	ACTIVE	SOIC	D	8	2500	RoHS & Green	NIPDAU	Level-1-260C-UNLIM	-40 to 85	V12IEP	<a href="#">Samples</a>
V62/05604-01XE	ACTIVE	SOIC	D	8	2500	RoHS & Green	NIPDAU	Level-1-260C-UNLIM	-40 to 125	V10QEP	<a href="#">Samples</a>
V62/05604-03XE	ACTIVE	SOIC	D	8	2500	RoHS & Green	NIPDAU	Level-1-260C-UNLIM	-40 to 85	V12IEP	<a href="#">Samples</a>
V62/05604-04XE	ACTIVE	SOIC	D	8	2500	RoHS & Green	NIPDAU	Level-1-260C-UNLIM	-55 to 125	V10MEP	<a href="#">Samples</a>

(1) The marketing status values are defined as follows:

**ACTIVE:** Product device recommended for new designs.

**LIFEBUY:** TI has announced that the device will be discontinued, and a lifetime-buy period is in effect.

**NRND:** Not recommended for new designs. Device is in production to support existing customers, but TI does not recommend using this part in a new design.

**PREVIEW:** Device has been announced but is not in production. Samples may or may not be available.

**OBSOLETE:** TI has discontinued the production of the device.

(2) **RoHS:** TI defines "RoHS" to mean semiconductor products that are compliant with the current EU RoHS requirements for all 10 RoHS substances, including the requirement that RoHS substance do not exceed 0.1% by weight in homogeneous materials. Where designed to be soldered at high temperatures, "RoHS" products are suitable for use in specified lead-free processes. TI may reference these types of products as "Pb-Free".

**RoHS Exempt:** TI defines "RoHS Exempt" to mean products that contain lead but are compliant with EU RoHS pursuant to a specific EU RoHS exemption.

**Green:** TI defines "Green" to mean the content of Chlorine (Cl) and Bromine (Br) based flame retardants meet JS709B low halogen requirements of <=1000ppm threshold. Antimony trioxide based flame retardants must also meet the <=1000ppm threshold requirement.

(3) MSL, Peak Temp. - The Moisture Sensitivity Level rating according to the JEDEC industry standard classifications, and peak solder temperature.

(4) There may be additional marking, which relates to the logo, the lot trace code information, or the environmental category on the device.

(5) Multiple Device Markings will be inside parentheses. Only one Device Marking contained in parentheses and separated by a "~" will appear on a device. If a line is indented then it is a continuation of the previous line and the two combined represent the entire Device Marking for that device.

(6) Lead finish/Ball material - Orderable Devices may have multiple material finish options. Finish options are separated by a vertical ruled line. Lead finish/Ball material values may wrap to two lines if the finish value exceeds the maximum column width.

**Important Information and Disclaimer:** The information provided on this page represents TI's knowledge and belief as of the date that it is provided. TI bases its knowledge and belief on information provided by third parties, and makes no representation or warranty as to the accuracy of such information. Efforts are underway to better integrate information from third parties. TI has taken and continues to take reasonable steps to provide representative and accurate information but may not have conducted destructive testing or chemical analysis on incoming materials and chemicals. TI and TI suppliers consider certain information to be proprietary, and thus CAS numbers and other limited information may not be available for release.

In no event shall TI's liability arising out of such information exceed the total purchase price of the TI part(s) at issue in this document sold by TI to Customer on an annual basis.

**OTHER QUALIFIED VERSIONS OF SN65HVD10-EP, SN65HVD12-EP :**

- Catalog: [SN65HVD10](#), [SN65HVD12](#)

NOTE: Qualified Version Definitions:

- Catalog - TI's standard catalog product

**TAPE AND REEL INFORMATION**

**QUADRANT ASSIGNMENTS FOR PIN 1 ORIENTATION IN TAPE**

\*All dimensions are nominal

Device	Package Type	Package Drawing	Pins	SPQ	Reel Diameter (mm)	Reel Width W1 (mm)	A0 (mm)	B0 (mm)	K0 (mm)	P1 (mm)	W (mm)	Pin1 Quadrant
SN65HVD10MDREP	SOIC	D	8	2500	330.0	12.4	6.4	5.2	2.1	8.0	12.0	Q1
SN65HVD10QDREP	SOIC	D	8	2500	330.0	12.4	6.4	5.2	2.1	8.0	12.0	Q1
SN65HVD12IDREP	SOIC	D	8	2500	330.0	12.4	6.4	5.2	2.1	8.0	12.0	Q1

**TAPE AND REEL BOX DIMENSIONS**

\*All dimensions are nominal

Device	Package Type	Package Drawing	Pins	SPQ	Length (mm)	Width (mm)	Height (mm)
SN65HVD10MDREP	SOIC	D	8	2500	340.5	336.1	25.0
SN65HVD10QDREP	SOIC	D	8	2500	340.5	336.1	25.0
SN65HVD12IDREP	SOIC	D	8	2500	340.5	336.1	25.0



D0008A

# PACKAGE OUTLINE

SOIC - 1.75 mm max height

SMALL OUTLINE INTEGRATED CIRCUIT



4214825/C 02/2019

NOTES:

1. Linear dimensions are in inches [millimeters]. Dimensions in parenthesis are for reference only. Controlling dimensions are in inches. Dimensioning and tolerancing per ASME Y14.5M.
2. This drawing is subject to change without notice.
3. This dimension does not include mold flash, protrusions, or gate burrs. Mold flash, protrusions, or gate burrs shall not exceed  $.006$  [0.15] per side.
4. This dimension does not include interlead flash.
5. Reference JEDEC registration MS-012, variation AA.

# EXAMPLE BOARD LAYOUT

D0008A

SOIC - 1.75 mm max height

SMALL OUTLINE INTEGRATED CIRCUIT



LAND PATTERN EXAMPLE  
EXPOSED METAL SHOWN  
SCALE:8X



SOLDER MASK DETAILS

4214825/C 02/2019

NOTES: (continued)

- 6. Publication IPC-7351 may have alternate designs.
- 7. Solder mask tolerances between and around signal pads can vary based on board fabrication site.

# EXAMPLE STENCIL DESIGN

D0008A

SOIC - 1.75 mm max height

SMALL OUTLINE INTEGRATED CIRCUIT



SOLDER PASTE EXAMPLE  
BASED ON .005 INCH [0.125 MM] THICK STENCIL  
SCALE:8X

4214825/C 02/2019

NOTES: (continued)

8. Laser cutting apertures with trapezoidal walls and rounded corners may offer better paste release. IPC-7525 may have alternate design recommendations.
9. Board assembly site may have different recommendations for stencil design.

## IMPORTANT NOTICE AND DISCLAIMER

TI PROVIDES TECHNICAL AND RELIABILITY DATA (INCLUDING DATASHEETS), DESIGN RESOURCES (INCLUDING REFERENCE DESIGNS), APPLICATION OR OTHER DESIGN ADVICE, WEB TOOLS, SAFETY INFORMATION, AND OTHER RESOURCES "AS IS" AND WITH ALL FAULTS, AND DISCLAIMS ALL WARRANTIES, EXPRESS AND IMPLIED, INCLUDING WITHOUT LIMITATION ANY IMPLIED WARRANTIES OF MERCHANTABILITY, FITNESS FOR A PARTICULAR PURPOSE OR NON-INFRINGEMENT OF THIRD PARTY INTELLECTUAL PROPERTY RIGHTS.

These resources are intended for skilled developers designing with TI products. You are solely responsible for (1) selecting the appropriate TI products for your application, (2) designing, validating and testing your application, and (3) ensuring your application meets applicable standards, and any other safety, security, or other requirements. These resources are subject to change without notice. TI grants you permission to use these resources only for development of an application that uses the TI products described in the resource. Other reproduction and display of these resources is prohibited. No license is granted to any other TI intellectual property right or to any third party intellectual property right. TI disclaims responsibility for, and you will fully indemnify TI and its representatives against, any claims, damages, costs, losses, and liabilities arising out of your use of these resources.

TI's products are provided subject to TI's Terms of Sale (<https://www.ti.com/legal/termsofsale.html>) or other applicable terms available either on [ti.com](https://www.ti.com) or provided in conjunction with such TI products. TI's provision of these resources does not expand or otherwise alter TI's applicable warranties or warranty disclaimers for TI products.

Mailing Address: Texas Instruments, Post Office Box 655303, Dallas, Texas 75265  
Copyright © 2021, Texas Instruments Incorporated